

Instruction

MI 020-585
November 2014

**I/A Series[®] Temperature Transmitter
Model RTT80-T with HART[®] 7 Protocol and Optional SIL
Certification**

Foxboro[®]
by Schneider Electric

Contents

Figures	5
Tables	7
1. Introduction	9
General Description	9
Reference Documents	9
Transmitter Identification.....	9
Standard Specifications.....	11
HART Communications Protocol	17
Electrical Certification Rating	17
Electrical Safety Specifications	17
ATEX Compliance Documents	18
PTB 12ATEX2006	18
FM 13ATEX0068X.....	18
IECEX Compliance Documents	19
IECEX PTB 12.0045	19
IECEX FMG 14.0005X.....	19
Warnings.....	19
2. Installation	21
Mounting.....	22
Requirements	22
Basic Module Mounting Options.....	23
Universal Housing Mounting Options.....	24
Dual Compartment Housing Mounting Options.....	25
Thermowell Mounting.....	26
Cover Locks	27
Universal Housing Cover Locks.....	27
Dual Compartment Housing Cover Locks	28
Wiring	28
Input Connections	29
Loop Wiring	30
Multidrop Communication.....	32
3. Operation	35

Operation via HART 7 Protocol	35
Operation via Optional -L1 Display.....	35
4. Operating Menu and Parameter Description.....	37
Setup Menu.....	42
Advanced Setup Submenu	44
Diagnostics Menu	58
Diagnostic List Submenu.....	59
Event Logbook Submenu.....	60
Device Information Submenu.....	61
Measured Values Submenu	62
Simulation Submenu	64
Expert Menu	65
System Submenu	65
Sensor Submenu	66
Output Submenu	71
Communication Submenu	71
Diagnostics Submenu	78
5. Maintenance.....	81
Troubleshooting	81
Replacing the Transmitter	83
DIN Rail Mounted Units.....	83
Universal Housing Mounted Units.....	83
Dual Compartment Housing Mounted Units	84
Diagnostics.....	84
Display.....	85
Device Interface.....	85

Figures

1	Typical Identification Label for Housing and Sensor Mounting Code BB (SIL and non-SIL) . 10	
2	Typical Identification Labels for Universal Housing	10
3	Typical Identification Labels for Dual Compartment Housing.....	11
4	Basic Module Mounting Options (Housing and Sensor Mounting Code BB)	23
5	Universal Housing Mounting Options (Housing and Sensor Mounting Codes SS, TT, LL, MM, WW, and YY)	24
6	Dual Compartment Housing Mounting Options: Remote Sensor (Housing and Sensor Mounting Codes GG, HH, QQ, and RR)	25
7	Dual Compartment Housing Mounting Options: Integral Sensor (Housing and Sensor Mounting Codes CC, DD, EE, FF, JJ, KK, NN, and PP)	26
8	Thermowell Mounting (Dual Compartment Housing Shown)	26
9	Universal Housing Cover Lock.....	27
10	Dual Compartment Housing Cover Locks	28
11	Input Connections on the Basic Module and Universal Housing.....	29
12	Dual Compartment Housing Wiring from the Terminal Block to the Module.....	29
13	Supply Voltage and Loop Load.....	30
14	Transmitter Loop Wiring	32
15	Wiring Several Transmitters to a Common Power Supply	32
16	Typical Multidrop Network.....	33
17	Display DIP Switches.....	36
18	Drift/difference Mode	45
19	Value only	52
20	Value + Bargraph.....	52
21	Display Information.....	52
22	Troubleshooting Diagram.....	82
23	Input Connections	83

Tables

1	Reference Documents	9
2	Input Types, Range Limits, Minimum Span (RTD or Ω)	12
3	Input Types, Range Limits, Minimum Span (TC or mV).....	13
4	Maximum Measured Error and Repeatability (RTD or Ω).....	14
5	Maximum Measured Error and Repeatability (TC or mV).....	15
6	Housing Specifications	16
7	Electrical Safety Specifications.....	18
8	Setup Menu	37
9	Diagnostics Menu	38
10	Expert Menu	39
11	Procedure for Configuring the Drift/Difference Mode	45
12	Procedure for Adjusting Analog Output	49
13	Display Information.....	53
14	Procedure for Sensor Trimming.....	67
15	Procedure for Configuring a Linearization using Callendar/Van Dusen Coefficients from a Calibration Certificate.....	68
16	Recommended Troubleshooting Steps Before Replacing Module	81
17	Diagnostic Errors	84
18	Diagnostic Severity.....	85
19	Diagnostic Events.....	86

1. Introduction

General Description

The RTT80 Temperature Transmitter is a microprocessor-based temperature transmitter that receives input signals from thermocouples, RTDs, resistance (ohms), or millivolt sources. It is offered in a basic module package or with universal or dual compartment housing options, and utilizes HART[®] revision 7 communications protocol. SIL functional safety certification is available as an option.

Reference Documents

For additional and related information, refer to the documents listed in Table 1.

Table 1. Reference Documents

Document	Description
PSS 2A-1F8 A	Product Specification Sheet: Model RTT80 I/A Series [®] Temperature Transmitter
MI 020-580	Master Instruction: RTT80 I/A Series [®] Temperature Transmitter FM/CSA Safety Information
MI 020-581	Master Instruction: RTT80 I/A Series [®] Temperature Transmitter ATEX/IECEX Safety Information
MI 020-582	Master Instruction: RTT80 I/A Series(R) Temperature Transmitter with HART 6 Protocol
MI 020-584	Master Instruction: 2-Channel Temperature Transmitter RTT80, HART [®] Protocol Functional Safety Manual
DP 020-580	Dimensional Print: Model RTT80 I/A Series [®] Temperature Transmitters
PL 008-680	Parts List: Model RTT80 I/A Series [®] Intelligent Temperature Transmitters

Transmitter Identification

See Figures 1, 2, and 3 for typical agency and data labels. For transmitters enclosed in a housing, the basic unit agency label is located on the basic unit and the applicable agency and data labels are externally mounted on the transmitter housing.

NOTE

Figures 1, 2, and 3 show typical data plates. For a recapitulation of the specific information that applies to each agency certification, see “Electrical Certification Rating” on page 17.

Figure 1. Typical Identification Label for Housing and Sensor Mounting Code BB (SIL and non-SIL)

Basic Transmitter
Module (Code BB)

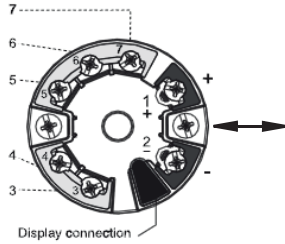

Agency Labels

SIL Label:
 S/N: XXXXXXXXXXXX
 DevRev: 2
 FW: 01.01.04
 Input: 11-30V
 Made in Germany 2014
 Current consum.: 23mA
 Part.no. D0271HD_A
 IECEx PTB 12.0045
 Ex ia IIC T5...T4 Ga
 Ta = -50...+58/75/85°C

Agency Labels:
 HART®
 HART Temperature Transmitter
 RTT80-T SIL
 Foxboro, MA 02035, USA
 by Schneider Electric
 IS: NI / Class I / Div. 1,2 / Group ABCD
 T6/T5/T4 Ta = -50...+58/75/85°C
 Install per drawing K0164YA
 Exia / NONINCENDIVE CL I, GP, ABCD
 T6/T5/T4 Ta = -50...+58/75/85°C
 Install per drawing K0164YC

Non-SIL Label:
 S/N: XXXXXXXXXXXX
 DevRev: 2
 FW: 01.01.04
 Input: 11-30V
 Made in Germany 2014
 Current consum.: 23mA
 Part.no. D0271HD_A
 IECEx PTB 12.0045
 Ex ia IIC T5...T4 Ga
 Ta = -50...+58/75/85°C

Agency Labels:
 HART®
 HART Temperature Transmitter
 RTT80-T
 Foxboro, MA 02035, USA
 by Schneider Electric
 IS: NI / Class I / Div. 1,2 / Group ABCD
 T6/T5/T4 Ta = -50...+58/75/85°C
 Install per drawing K0164YA
 Exia / NONINCENDIVE CL I, GP, ABCD
 T6/T5/T4 Ta = -50...+58/75/85°C
 Install per drawing K0164YC

Figure 2. Typical Identification Labels for Universal Housing

Universal Housing
(Codes LL, MM, SS, TT,
WW, and YY)

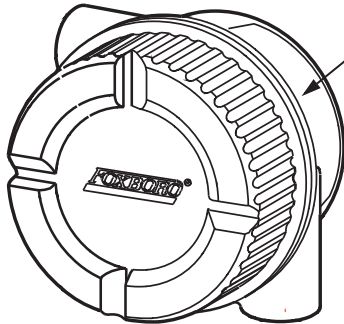

IECEx Agency Label

SEE CERTIFICATES FOR ELECTRICAL DATA

ED Ex d IIC T6 GbT6; -40°C to 70°C
 Ex tb IIC T6°C D0/T6; -40°C to 70°C
 IECEx FMG 14.0005X; IP 66/67

EA Ex ia IIC T5, T4 Ga, T6; T6; -40°C to 45°C
 T5; T6; -50°C to 60°C; T4; T6; -50°C to 60°C
 IECEx PTB 12.0045; IP 66/67

WARNING – DO NOT OPEN WHEN ENERGIZED

K0168LL

Flameproof and Intrinsic Safety Agency Label

SEE CERTIFICATES FOR ELECTRICAL DATA

AD II 2 GD Ex d IIC T6 GbT6; -40°C to 70°C
 Ex tb IIC T6°C D0/T6; -40°C to 70°C
 FM 13ATEX0068X; IP 66/67

AA II 2D Ex ia IIC T5, T4 Ga, T6; T6; -40°C to 55°C
 T5; T6; -40°C to 70°C; T4; T6; -40°C to 85°C
 PTB 12ATEX2005; IP 66/67

WARNING – DO NOT OPEN WHEN ENERGIZED

K0168SY

Explosion Proof and Intrinsic Safety Agency Label (FM)

XP CL I, DIV 1, GP B, C, D; DIP CL II, III, DIV 1 GP E, F, G; T5 Ta = -40°C to +80°C; T6 -40°C to +70°C
 CL I, ZN 1, AEx d IIC; T5 Ta = -40°C to +80°C; T6 -40°C to +70°C

IS CL I, DIV 1, GP A, B, C, D; CL I, ZN 0, AEx ia IIC; T4, Ta = -40°C to +85°C;
 T5, Ta = -40°C to +70°C; T6, Ta = -40°C to +55°C; Install Per Drawing K0164YA

NI CL I, DIV 2, GP A, B, C, D; T4 Ta = -40°C to +85°C; T5, Ta = -40°C to +70°C;
 T6, Ta = -40°C to +55°C; Install Per Drawing K0164YA

Type 4X / IP66/67
 WARNING: EXPLOSION HAZARD: Keep Cover tight while circuits are live unless area is known to be Non-Hazardous.
 Substitution of components may impair Intrinsic Safety or Division 2 Approval.
 SEAL NOT REQUIRED

D0197UK

Data Label

Invensys
FOXBORO I/A Series® TEMPERATURE TRANSMITTER

MODEL	ST	ORIGIN
REF NO.	SER NO.	SUPPLY
RANGE	MWP	
CUST DATA		

INVENSYS SYSTEMS, INC.
 33 Commercial St.
 FORTBORO, MA, U.S.A.

Figure 3. Typical Identification Labels for Dual Compartment Housing

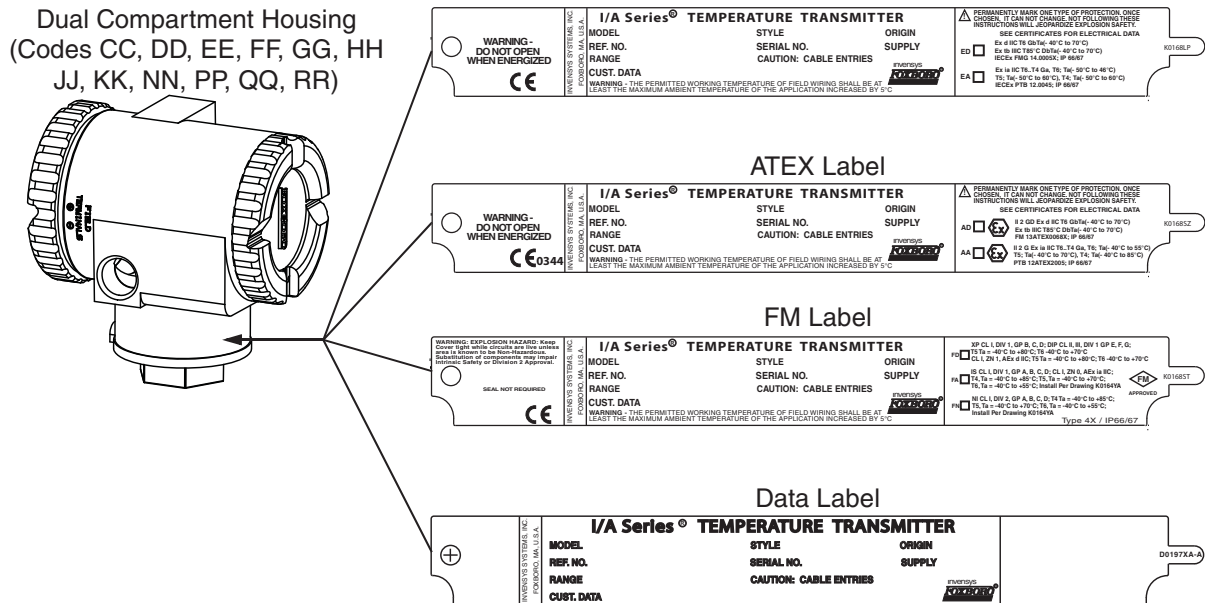

Standard Specifications

Ambient Temperature Limits:

-40 and +85°C (-40 and +185°F)

— NOTE —

To ensure proper operation, the ambient temperature limits at the housing should not be exceeded. This is particularly relevant when sensors/thermowells are directly connected to the housing and very high process temperatures are being measured. The transfer of heat from the process to the housing can be minimized by use of thermowell extensions, or in extreme cases, by using a remote housing installation.

Supply Voltage Limits:

11 and 42 V dc in Normal mode

11 and 32 V dc in SIL mode

$V_{max} = 30$ V dc when certified as intrinsically safe.

Vibration Limits:

- ◆ Basic Transmitter Module, Housing and Sensor Mounting Code BB: 25 to 100 Hz for 4g per GL-guidelines, Chapter 2, 2003 Edition.
- ◆ RTT80 Housing and Sensor Mounting Codes CC, EE, GG, JJ, LL, NN, QQ, SS, and WW: 19 mm (0.75 in) Double Amplitude from 5 to 9 Hz, 0 to 30 m/s² (0 to 3 “g”) from 9 to 500 Hz
- ◆ RTT80 Housing and Sensor Mounting Codes DD, FF, HH, KK, MM, PP, RR, TT, and YY: 10 m/s² (1 g) maximum.

Type of Input

It is possible to connect two sensor inputs which are independent of each other. These are not galvanically isolated from each other.

Table 2. Input Types, Range Limits, Minimum Span (RTD or Ω)

Resistance Thermometer (RTD) as Per Standard	Designation	a	Measuring Range Limits	Min Span
IEC 60751:2008	Pt100 (1) Pt200 (2) Pt500 (3) Pt1000 (4)	0.003851	-200 to +850°C (-328 to +1562°F) -200 to +850°C (-328 to +1562°F) -200 to +500°C (-328 to +932°F) -200 to +250°C (-328 to +482°F)	10 K (18°F)
JIS C1604:1984	Pt100 (5)	0.003916	-200 to +510°C (-328 to +950°F)	10 K (18°F)
DIN 43760 IPTS-68	Ni100 (6) Ni120 (7)	0.006180	-60 to +250°C (-76 to +482°F) -60 to +250°C (-76 to +482°F)	10 K (18°F)
GOST 6651-94	Pt50 (8) Pt100 (9)	0.003910	-185 to +1100°C (-301 to +2012°F) -200 to +850°C (-328 to +1562°F)	10 K (18°F)
OIML R84: 2003, GOST 6651-2009	Cu50 (10) Cu100 (11)	0.004280	-180 to +200°C (-292 to +392°F) -180 to +200°C (-292 to +392°F)	10 K (18°F)
	Ni100 (12) Ni120 (13)	0.006170	-60 to +180°C (-76 to +356°F) -60 to +180°C (-76 to +356°F)	10 K (18°F)
OIML R84: 2003, GOST 6651-94	Cu50 (14)	0.004260	-50 to +200°C (-58 to +392°F)	10 K (18°F)
-	Pt100 (Callendar-van Dusen)	-	The measuring range limits are specified by entering the limit values that depend on the coefficients A to C and R0.	10 K (18°F)
-	Nickel Polynomial	-		
-	Copper Polynomial	-		
	▶ Type of connection: 2-wire, 3-wire or 4-wire connection, sensor current: ≤ 0.3 mA ▶ With 2-wire circuit, compensation of wire resistance possible (0 to 30 Ω¶) ▶ With 3-wire and 4-wire connection, sensor wire resistance up to max. 50 Ω¶ per wire			
Resistance Transmitter	Resistance Ω		10 and 400 Ω 10 and 2000 Ω	10 Ω 10 Ω

Table 3. Input Types, Range Limits, Minimum Span (TC or mV)

Thermo-couples (TC) as Per Standard	Designation	Configurable Measuring Range Limits		Min Span
IEC 60584, Part 1	Type A (W5Re-W20Re)(30) Type B (PtRh30-PtRh6)(31) Type E (NiCr-CuNi) (34) Type J (Fe-CuNi) (35) Type K (NiCr-Ni) (36) Type N (NiCrSi-NiSi) (37) Type R (PtRh13-Pt) (38) Type S (PtRh10-Pt) (39) Type T (Cu-CuNi) (40)	0 to +2500°C (+32 to +4532°F) +40 to +1820°C (+104 to +3308°F) -270 to +1000°C (-454 to +1832°F) -210 to +1200°C (-346 to +2192°F) -270 to +1372°C (-454 to +2501°F) -270 to +1300°C (-454 to +2372°F) -50 to +1768°C (-58 to +3214°F) -50 to +1768°C (-58 to +3214°F) -260 to +400°C (-436 to +752°F)	Recommended temperature range: 0 to +2500°C (+32 to +4532°F) +100 to +1500°C (+212 to +2732°F) 0 to +750°C (+32 to +1382°F) +20 to +700°C (+68 to +1292°F) 0 to +1 100°C (+32 to +2012°F) 0 to +1 100°C (+32 to +2012°F) 0 to +1 400°C (+32 to +2552°F) 0 to +1 400°C (+32 to +2552°F) -185 to +350°C (-301 to +662°F)	50 K (90°F)
IEC 60584, Part 1; ASTM E988-96	Type C (W5Re-W26Re) (32)	0 to +2315°C (+32 to +4199°F)	0 to +2000°C (+32 to +3632°F)	50 K (90°F)
ASTM E988-96	Type D (W3Re-W25Re) (33)	0 to +2315°C (+32 to +4199°F)	0 to +2000°C (+32 to +3632°F)	50 K (90°F)
DIN 43710	Type L (Fe-CuNi) (41) Type U (Cu-CuNi) (42)	-200 to +900°C (-328 to +1652°F) -200 to +600°C (-328 to +1112°F)	0 to +750°C (+32 to +1382°F) -185 to +400°C (-301 to +752°F)	50 K (90°F)
GOST R8.8585-2001	Type L (NiCr-CuNi) (43)	Type L (NiCr-CuNi) (43) -200 to +800°C (-328 to +1472°F)	0 to +750°C (+32 to +1382°F)	50 K (90°F)
	<ul style="list-style-type: none"> ▶ Internal cold junction (Pt100) ▶ External cold junction: configurable value -40 to +85°C (-40 to +185°F) ▶ Max. sensor resistance k10 kΩ (if sensor resistance is greater than 10 kΩ, an error message as per NAMUR NE89 is output) 			
Voltage Transmitter (mV)	Millivolt Transmitter (mV)	-20 to 100 mV		5 mV

Maximum Measured Error and Repeatability

According to DIN EN 60770. The data concerning the various measured errors are typical values and correspond to a standard deviation of $\pm 2 s$ (Gaussian normal distribution). Overall measured error of the device at current output = digital measured error + measured error D/A. See Table 4 and Table 5.

Table 4. Maximum Measured Error and Repeatability (RTD or Ω)

Resistance Thermometer (RTD) According to Standard	Designation	Measuring Range Limits	Measured Error (\pm)		Repeatability (\pm)	
			Digital (a)	D/A (b)	Digital (a)	D/A (c)
IEC 60751:2008	Pt100 (1)	-200 to +850°C (-328 to +1562°F)	≤ 0.14 K (0.25°F)	0.03 %	≤ 0.05 K (0.09°F)	0.01 % ($\triangleq 2 \mu\text{A}$)
	Pt200 (2)		≤ 0.86 K (1.55°F)		≤ 0.13 K (0.23°F)	
	Pt500 (3)	-200 to +500°C (-328 to +932°F)	≤ 0.30 K (0.54°F)		≤ 0.08 K (0.14°F)	
	Pt1000 (4)	-200 to +250°C (-328 to +482°F)	≤ 0.14 K (0.25°F)		≤ 0.05 K (0.09°F)	
JIS C1604:1984	Pt100 (5)	-200 to +510°C (-328 to +950°F)	≤ 0.12 K (0.22°F)		≤ 0.04 K (0.07°F)	
DIN 43760 IPTS-68	Ni100 (6)	-60 to +250°C (-76 to +482°F)	≤ 0.09 K (0.16°F)		≤ 0.03 K (0.05°F)	
	Ni120 (7)		≤ 0.07 K (0.13°F)			
GOST	Pt50 (8)	-185 to +1100°C (-301 to +2012°F)	≤ 0.30 K (0.54°F)		≤ 0.05 K (0.09°F)	
	Pt100 (9)	-200 to +850 °C (-328 to +1562°F)	≤ 0.14 K (0.25°F)		≤ 0.07 K (0.13°F)	
OIML R84: 2003, GOST 6651-2009	Cu50 (10)	-180 to +200°C (-292 to +392°F)	≤ 0.19 K (0.34°F)		≤ 0.04 K (0.07°F)	
	Cu100 (11)	-180 to +200°C (-292 to +392°F)	≤ 0.09 K (0.16°F)		≤ 0.03 K (0.05°F)	
	Ni100 (12)	-60 to +180°C (-76 to +356°F)	≤ 0.09 K (0.16°F)		≤ 0.07 K (0.13°F)	
	Ni120 (13)	-60 to +180°C (-76 to +356°F)				
OIML R84: 2003, GOST 6651-94	Cu50 (14)	-50 to +200°C (-58 to +392°F)	≤ 0.19 K (0.34°F)		15 m Ω ≤ 200 m Ω	
Resistance transmitters	Resistance Ω	10 to 400 Ω 10 to 2000 Ω	40 Ω 500 Ω	15 m Ω ≤ 200 m Ω		

- a. Using HART® transmitted measured value.
- b. Percentage data refer to the configured span of the analog output signal.
- c. Percentage data refer to the current range of the analog output signal (20 mA).

Table 5. Maximum Measured Error and Repeatability (TC or mV)

Thermocouples (TC) According to Standard	Designation	Measuring Range Limits (a)	Measured Error (\pm)		Repeatability (\pm)	
			Digital (b)	D/A (c)	Digital (b)	D/A (d)
IEC 60584, part 1	Type A (W5Re-W20Re) (30)	0 to 2500 °C (+32 to + 4532°F)	≤ 1.62 K (2.92°F)	0.03 %	≤ 0.52 K (0.94°F)	0.01% ($\pm 2\mu\text{A}$)
	Type B (PtRh30-PtRh6) (31)	+500 to +1820°C (+932 to +3308°F)	≤ 2.02 K (3.64°F)		≤ 0.67 K (1.21°F)	
	Type E (NiCr-CuNi) (34)	-40 to +1000°C (-40 to +1832°F)	≤ 0.21 K (0.38°F)		≤ 0.07 K (0.13°F)	
	Type J (Fe-CuNi) (35)	-40 to +1200°C (-40 to +2192°F)	≤ 0.26 K (0.47°F)		≤ 0.08 K (0.14°F)	
	Type K (NiCr-Ni) (36)	-40 to +1200°C (-40 to +2192°F)	≤ 0.32 K (0.58°F)		≤ 0.11 K (0.20°F)	
	Type N (NiCrSi-NiSi) (37)	-40 to +1300°C (-40 to +2372°F)	≤ 0.43 K (0.77°F)		≤ 0.16 K (0.29°F)	
	Type R (PtRh13-Pt) (38)	0 to +1768°C (+32 to +3214°F)	≤ 1.92 K (3.46°F)		≤ 0.76 K (1.37°F)	
	Type S (PtRh10-Pt) (39)	0 to +1768°C (+32 to +3214°F)	≤ 1.9 K (3.42°F)		≤ 0.74 K (1.33°F)	
	Type T (Cu-CuNi) (40)	-40 to +400°C (-40 to +752°F)	≤ 0.32 K (0.58°F)		≤ 0.11 K (0.20°F)	
IEC 60584, part 1; ASTM E988-96	Type C (W5Re-W26Re) (32)	0 to +2000°C (+32 to +3632°F)	≤ 0.86 K (1.55°F)		≤ 0.33 K (0.59°F)	
ASTM E988-96	Type D (W3Re-W25Re) (33)	0 to +2000°C (+32 to +3632°F)	≤ 1.05 K (1.89°F)		≤ 0.41 K (0.74°F)	
DIN 43710	Type L (Fe-CuNi) (41)	+50 to +900°C (+122 to +1652°F)	≤ 0.26 K (0.47°F)		≤ 0.07 K (0.13°F)	
	Type U (Cu-CuNi) (42)	+50 to +600°C (+122 to +1112°F)	≤ 0.24 K (0.43°F)		≤ 0.10 K (0.18°F)	
GOST R8.8585-2001	Type L (NiCr-CuNi) (43)	-200 to +800°C (-328 to +1472°F)	≤ 2.27 K (4.09°F)		≤ 0.15 K (0.27°F)	
Voltage transmitters	Millivolt transmitter (mV)	-20 to 100 mV	10 μV		4 μV	

a. Ranges over which stated Error and Repeatability apply. Input may be configured to wider range. See Table 3.

b. Using HART® transmitted measured value.

c. Percentage data refer to the configured span of the analog output signal.

d. Percentage data refer to the current range of the analog output signal (20 mA).

Table 6. Housing Specifications

Housing Code	Material and Finish	IEC/NEMA Rating	Explosion-proof and Flameproof	Mounting Configuration	Field Wiring Entrances on Housing
Basic Module					
BB	Encapsulated plastic	IP20 (a)	No	Basic Transmitter Module (b) (DIN Form B package)	None
Universal Housing					
LL	Low copper aluminum alloy; epoxy coated	IP66/67 NEMA 4X	Yes	Universal housing with integral sensor and thermowell	1/2 NPT
MM	Stainless steel	IP66/67 NEMA 4X	Yes	Universal housing with integral sensor and thermowell	1/2 NPT
SS	Low copper aluminum alloy; epoxy coated	IP66/67 NEMA 4X	Yes	Universal housing for surface or pipe mounting, remote sensor (c)	1/2 NPT
TT	Stainless steel	IP66/67 NEMA 4X	Yes	Universal housing for surface or pipe mounting, remote sensor (c)	1/2 NPT
WW	Low copper aluminum alloy; epoxy coated	IP66/67 NEMA 4X	Yes	Universal housing with integral bare sensor	1/2 NPT
YY	Stainless steel	IP66/67 NEMA 4X	Yes	Universal housing with integral bare sensor	1/2 NPT
Dual Compartment Housing (d)					
CC	Low copper aluminum alloy; epoxy coated	IP66/67 NEMA 4X	Yes	Dual-compartment housing with integral bare sensor	M20
DD	Stainless steel	IP66/67 NEMA 4X	Yes	Dual-compartment housing with integral bare sensor	M20
EE	Low copper aluminum alloy; epoxy coated	IP66/67 NEMA 4X	Yes	Dual-compartment housing with integral sensor and thermowell	M20
FF	Stainless steel	IP66/67 NEMA 4X	Yes	Dual-compartment housing with integral sensor and thermowell	M20
GG	Low copper aluminum alloy; epoxy coated	IP66/67 NEMA 4X	Yes	Dual-compartment housing for surface or pipe mounting, remote sensor (c)	M20
HH	Stainless steel	IP66/67 NEMA 4X	Yes	Dual-compartment housing for surface or pipe mounting, remote sensor (c)	M20
JJ	Low copper aluminum alloy; epoxy coated	IP66/67 NEMA 4X	Yes	Dual-compartment housing with integral bare sensor	1/2 NPT
KK	Stainless steel	IP66/67 NEMA 4X	Yes	Dual-compartment housing with integral bare sensor	1/2 NPT
NN	Low copper aluminum alloy; epoxy coated	IP66/67 NEMA 4X	Yes	Dual-compartment housing with integral sensor and thermowell	1/2 NPT
PP	Stainless steel	IP66/67 NEMA 4X	Yes	Dual-compartment housing with integral sensor and thermowell	1/2 NPT
QQ	Low copper aluminum alloy; epoxy coated	IP66/67 NEMA 4X	Yes	Dual-compartment housing for surface or pipe mounting, remote sensor (c)	1/2 NPT
RR	Stainless steel	IP66/67 NEMA 4X	Yes	Dual-compartment housing for surface or pipe mounting, remote sensor (c)	1/2 NPT

- a. The basic module, although encapsulated, has exposed terminals not protected from the environment.
- b. The basic module is typically used for replacement and spares purposes; it can also be mounted to a surface or to a DIN rail using a clip (Option -D1).
- c. Surface or pipe mounted using mounting set options -M1 or -M2.
- d. Differential heating of the dual compartment housing may result in offset of primary value equivalent to the temperature difference between housing compartments when thermocouples are used.

! WARNING

For all RTT80-T Transmitters with an aluminum housing:
When used in a potentially explosive atmosphere requiring apparatus of equipment category 1 G, the transmitter must be installed so that, even in the event of rare instances, an ignition source due to impact or friction between the enclosure and iron/steel is excluded. This shall be considered during installation, particularly if the equipment is installed in a zone 0 location.

HART Communications Protocol

Protocol Revision: 7

Communication Rate: 1200 baud

Communication Distance:

Analog Mode: 3050 m (10,000 ft)

Multidrop Mode: 1525 m (5000 ft)

Electrical Certification Rating

The electrical certification is printed on the agency label which is located on the basic module and on the transmitter housing (if applicable). The Electrical Safety Design Code is also included as part of the model code on the data label which is located on the basic module or on the transmitter housing (if applicable). See Figure 2 and Figure 3 for examples of typical agency and data labels. For a complete explanation of the model code, see PL 008-680.

Electrical Safety Specifications

NOTE

These transmitters have been designed to meet the electrical safety description listed in Table 7. For detailed information or status of testing laboratory approvals/certifications, contact Invensys.

Table 7. Electrical Safety Specifications

Testing Laboratory, Type of Protection, and Area Classification	Model Code Option
Non-hazardous area	ZZ
CSA IS, I/1+2/ABCD (a)	CA
CSA NI, 1/2/ABCD (a)	CN
CSA Explosionproof, Class I, Division 1, BCD; Dust-ignitionproof, Class II, Division 1, EFG, Class III, Division 1. Also zone certified, Cl I, Zone 1, EX d IIC (a) (b)	CD
ATEX II 1G Ex ia IIC T4/T5/T6	AA
ATEX II 2 G Ex d T6 Gb Ta = -40°C to 70°C II 2 D Ex tb T85C Db (b)	AD
IECEX Ex ia IIC T4/T5/T6	EA
IECEX Ex d T6 Gb Ta = -40°C to 70°C Ex tb T85C Db (b)	ED
FM IS, I/1+2/ABCD	FA
FM NI, I/2/ABCD	FN
FM Explosionproof, Class I, Division 1, Groups B, C, and D; Dust-ignitionproof, Class II, Division 1, Groups E, F, and G, Class III Division 1	FD

a. Not available with dual compartment housings.

b. Not available with the basic module (Housing and Sensor Mounting Code BB).

ATEX Compliance Documents

Directive 94/9/EC – Equipment or Protective Systems Intended for Use in Potentially Explosive Atmospheres.

Also, compliance with the essential health and safety requirements has been assured by compliance with the following documents as stated in the compliance certificate:

PTB 12ATEX2006

II 2G Ex ia IIC T6..T4 Ga, T6; Ta (- 40°C to 55°C); T5; Ta (-40°C to 70°C), T4;
Ta (-40°C to 85°C)
EN 60079-0:2009; EN 60079-11:2007

FM 13ATEX0068X

II 2 GD Ex d IIC T6 Gb Ta (-40°C to 70°C)
Ex tb IIC T85°C Db Ta (-40°C to 70°C)
EN 60079-0:2009; EN 60079-1:2007; EN 60079-31:2009

IECEX Compliance Documents

IECEX PTB 12.0045

Ex ia IIC T6..T4 Ga, T6; Ta(-50°C to 46°C)
 T5; Ta(-50°C to 60°C), T4; Ta(-50°C to 60°C)
 IEC 60079-0:2007-10 (edition 5); IEC 60079-11:2011 (edition 6); IEC 60079-26:2006
 (edition 2)

IECEX FMG 14.0005X

Ex d IIC T6 Gb Ta = -40°C to 70°C
 Ex tb IIIC T85°C Db Ta = -40°C to 70°C
 IEC 60079-0:2007-10 (edition 5); IEC 60079-1:2007(edition 6); IEC 60079-31:2013
 (edition 2)

Warnings

! WARNING
 Do not open while circuits are energized.

! WARNING
 Do not open when energized or when an explosive atmosphere may be present.

! WARNING
 Substitution of components may impair intrinsic safety or Division 2 approvals.

! WARNING
 The certificate numbers have an 'X' suffix which indicates that special conditions of installation and use apply. Those installing or inspecting this equipment must have access to the contents of the certificate or these instructions. The conditions listed in the certificate are reproduced below.

1. Some models have the main electronics enclosure manufactured from aluminum alloy. In rare cases, ignition sources due to impact and friction sparks could occur. This shall be considered during installation, particularly if the equipment is installed in a zone 0 location.
2. When installed in flammable dust zones, under certain extreme circumstances an incendive electrostatic charge may build up on the painted surfaces, which are non-conducting. Therefore, the user/installer shall implement precautions to prevent the build up of electrostatic charge, for example, locate the equipment where a charge-generating mechanism (such as wind-blown dust) is unlikely to be present and clean with a damp cloth.
3. When installed in a flammable dust zone, the installer shall ensure that the cable entry maintains the dust-tightness (IP6X) of the enclosure.

For explosionproof certifications:

—  **WARNING** —————
Keep cover tight while circuits are energized unless area is known to be nonhazardous.
—————

—  **WARNING** —————
To prevent ignition of flammable or combustible atmospheres, disconnect power
before servicing.
—————

2. Installation

The following material provides information and procedures for installing the RTT80 Transmitter. For dimensional information, refer to DP 020-580.

Installation shall be carried out in accordance with the applicable code of practice (typically IEC 60079-14) by suitably trained personnel.

There are no special checking or maintenance conditions. All explosion-protected equipment should be periodically inspected in accordance with the applicable code of practice (typically IEC 60079-17). The interval between inspections should not normally exceed 3 years, unless justification for a longer interval is given.

With regard to explosion safety, it is not necessary to check for correct operation.

— **NOTE** —

Use a suitable thread sealant on all connections.

—  **CAUTION** —

Bare sensor or thermowell mounting to the 316 ss housing should not be used in high vibration areas.

—  **CAUTION** —

The RTT80 is only certified for use in ambient temperatures marked on the equipment and should not be used outside this range.

—  **CAUTION** —

The maximum process pressure indicated on the marking must not be exceeded.

—  **CAUTION** —

The maximum permitted ambient temperature of the RTT80 temperature transmitter is 85°C. To avoid the effects of process temperature and other thermal effects, care shall be taken to ensure that the electronics housing temperature does not exceed an ambient temperature of 85°C.

Mounting

The transmitter is offered in a basic module package or with universal or dual compartment housing options. The basic transmitter module can be mounted on a flat surface or on a DIN rail using a simple clip. It is assumed that sufficient environmental protection is provided when a basic transmitter is used without a housing.

The transmitter is also offered with either a rugged universal housing, which accommodates the electronics and terminations in a single compartment, or a dual-compartment housing, which isolates and seals the wiring terminals from the electronics compartment. The transmitter in a field housing can be pipe mounted, surface mounted, mounted directly to a bare sensor, or thermowell mounted. See Figure 4 through Figure 8.

For extremely high process temperatures, a remote mounted sensor is recommended. Also, the mounting stability can influence how the sensor is attached to the transmitter. If the process vessel is highly insulated and the thermowell has considerable lagging, a remote mounted transmitter attached to a 50 mm (2 inch) pipe is recommended. When mounting the transmitter, take into account the necessary room to remove the cover.

Requirements

1. For all versions, the sensor circuit is not infallibly galvanically isolated from the input circuit. However, the galvanic isolation between the circuits is capable of withstanding a test voltage of 500 Vac during 1 minute.
2. For RTT80-T with universal or dual compartment housings, be sure to use cable entries and blanking elements that are suitable for the application and are correctly installed.
3. For all versions with an ambient temperature $\geq 60^{\circ}\text{C}$, heat resistant cables with a rating of at least 20 K above the ambient temperature must be used.
4. For Type RTT80-T with Housing and Sensor Mounting Code BB, the transmitter must be mounted in an enclosure in order to provide a degree of ingress protection of at least IP20.
5. For Type RTT80-T with Housing and Sensor Mounting Code BB, the transmitter may only be installed in a potentially explosive atmosphere caused by the presence of combustible dust when mounted in a metal enclosure according to DIN 43729 that is providing a degree of protection of at least IP66/67 in accordance with EN 60529.

Basic Module Mounting Options

Figure 4. Basic Module Mounting Options (Housing and Sensor Mounting Code BB)

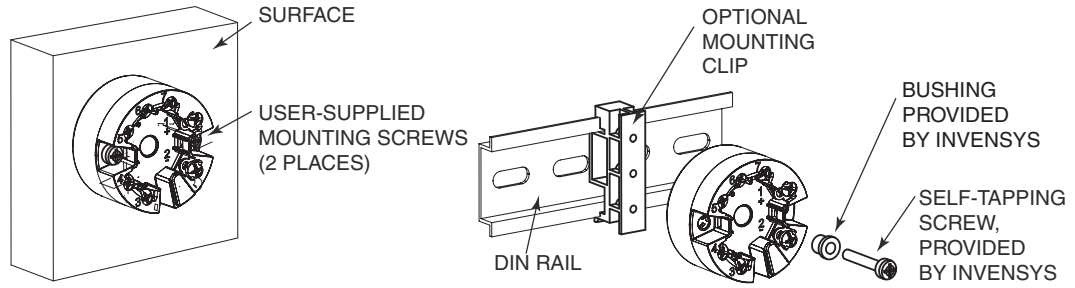

Universal Housing Mounting Options

Figure 5. Universal Housing Mounting Options (Housing and Sensor Mounting Codes SS, TT, LL, MM, WW, and YY)

UNIVERSAL HOUSING FOR SURFACE OR PIPE MOUNT WITH REMOTE SENSOR

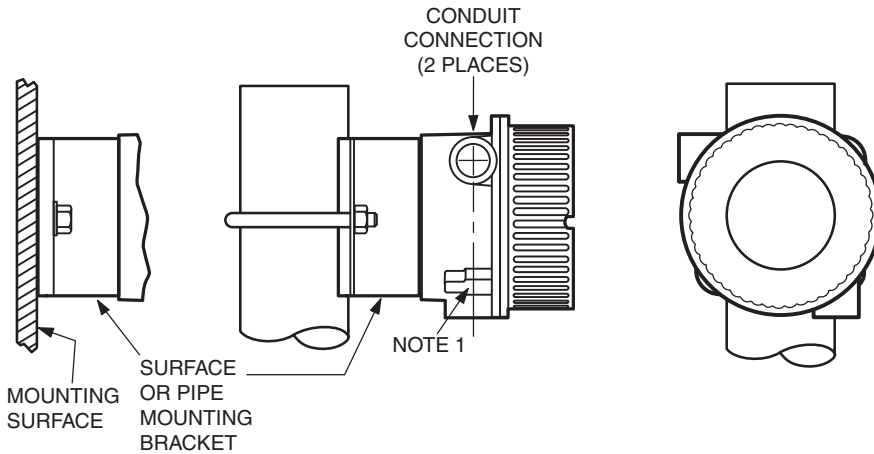

HOUSING CODES
 SS = ALUMINUM
 TT = 316 ss

NOTE 1
 EXTERNAL COVER
 LOCK AND GROUND
 SCREW WHEN
 APPLICABLE.

UNIVERSAL HOUSING WITH INTEGRAL SENSOR

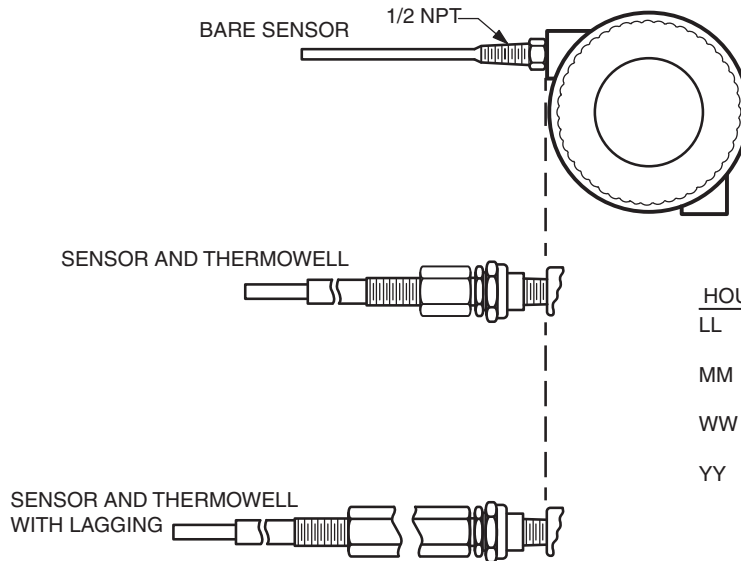

HOUSING CODES
 LL = ALUMINUM HOUSING
 FOR SENSOR AND WELL
 MM = 316 ss HOUSING
 FOR SENSOR AND WELL
 WW = ALUMINUM HOUSING
 WITH BARE SENSOR
 YY = 316 ss HOUSING
 WITH BARE SENSOR

Dual Compartment Housing Mounting Options

Figure 6. Dual Compartment Housing Mounting Options: Remote Sensor (Housing and Sensor Mounting Codes GG, HH, QQ, and RR)

DUAL COMPARTMENT HOUSING FOR SURFACE OR PIPE MOUNT WITH REMOTE SENSOR

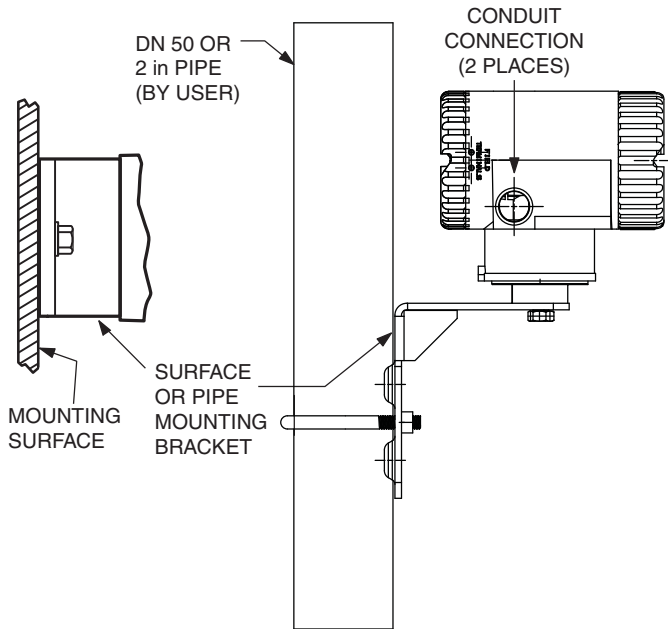

HOUSING CODES

- GG = ALUMINUM M20 HOUSING FOR REMOTE SENSOR
- HH = 316 ss M20 HOUSING FOR REMOTE SENSOR
- QQ = ALUMINUM 1/2 NPT HOUSING FOR REMOTE SENSOR
- RR = 316 ss 1/2 NPT HOUSING FOR REMOTE SENSOR

Figure 7. Dual Compartment Housing Mounting Options: Integral Sensor (Housing and Sensor Mounting Codes CC, DD, EE, FF, JJ, KK, NN, and PP)

DUAL COMPARTMENT HOUSING WITH INTEGRAL SENSOR AND/OR SENSOR AND THERMOWELL

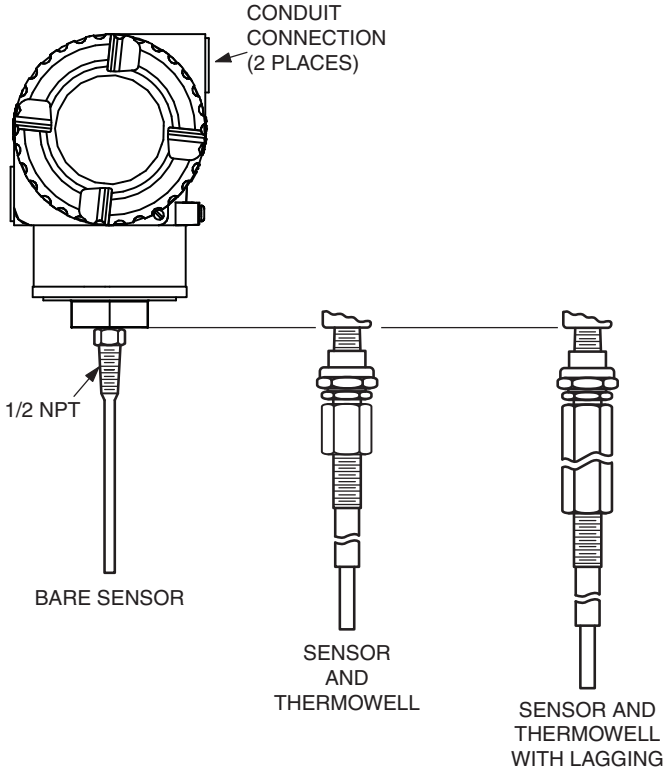

HOUSING CODES

- CC = ALUMINUM M20 HOUSING WITH BARE SENSOR
- DD = 316 SS M20 HOUSING WITH BARE SENSOR
- EE = ALUMINUM M20 HOUSING WITH SENSOR AND THERMOWELL
- FF = 316 SS M20 HOUSING WITH SENSOR AND THERMOWELL
- JJ = ALUMINUM 1/2 NPT HOUSING WITH BARE SENSOR
- KK = 316 SS 1/2 NPT HOUSING WITH BARE SENSOR
- NN = ALUMINUM 1/2 NPT HOUSING WITH SENSOR AND THERMOWELL
- PP = 316 SS 1/2 NPT HOUSING WITH SENSOR AND THERMOWELL

Thermowell Mounting

Figure 8. Thermowell Mounting (Dual Compartment Housing Shown)

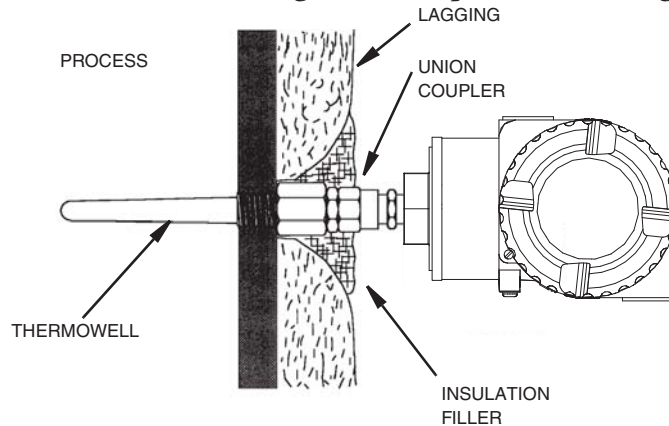

Cover Locks

A cover lock is provided as standard with certain agency certifications and as part of the Custody Transfer Lock and Seal option. The type of lock varies with the housing used.

Universal Housing Cover Locks

To lock the cover on the universal housing:

1. Tighten the cover on the housing until the flange on the cover comes into contact with the flange on the housing.
2. Place the clamp as shown below and tighten the clamp screw.
3. Insert the seal wire through the clamp and crimp the seal if applicable.

Figure 9. Universal Housing Cover Lock

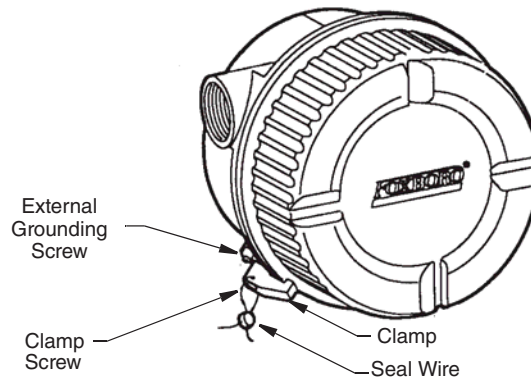

Dual Compartment Housing Cover Locks

To lock the covers on the dual compartment housing:

1. Tighten each cover on the housing until the flange on the cover comes into contact with the flange on the housing.
2. Tighten the locking screw as shown below and tighten the clamp screw.
3. Insert the seal wire through the clamp and crimp the seal if applicable.

Figure 10. Dual Compartment Housing Cover Locks

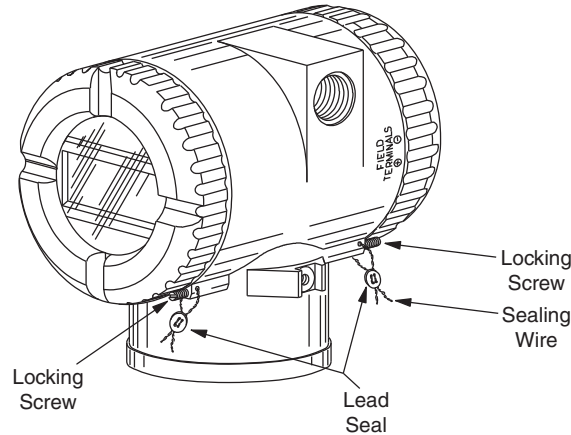

Wiring

Your transmitter must be installed to meet all local installation regulations, such as hazardous location requirements and electrical wiring codes. Persons involved in the installation must be trained in these code requirements. To maintain agency certification, your transmitter must also be installed in accordance with the agency requirements.

! WARNING

To maintain IEC IP66/67 and NEMA Type 4X protection on transmitters with universal housings, any unused conduit opening must be plugged with a metal plug. In addition, the threaded housing cover must be installed. Hand tighten the cover so that the O-ring is fully captured, making sure that the flange of the cover comes into contact with the flange of the housing

NOTE

It is recommended that you use transient/surge protection in installations prone to high levels of electrical transients and surges.

Input Connections

There are seven terminals on the basic module for input and output connections. Terminals 1 and 2 are for bus power and measurement output and terminals 3 through 7 are for RTD, TC, ohm, or mV sensor inputs. See Figure 11.

In the dual-compartment housing with remote sensor, the bus and sensor connections are made through the terminal block in the customer connection side of the housing. The terminals are identified with the same numbers as the module connections and the wires are color-coded as indicated in Figure 12.

Figure 11. Input Connections on the Basic Module and Universal Housing

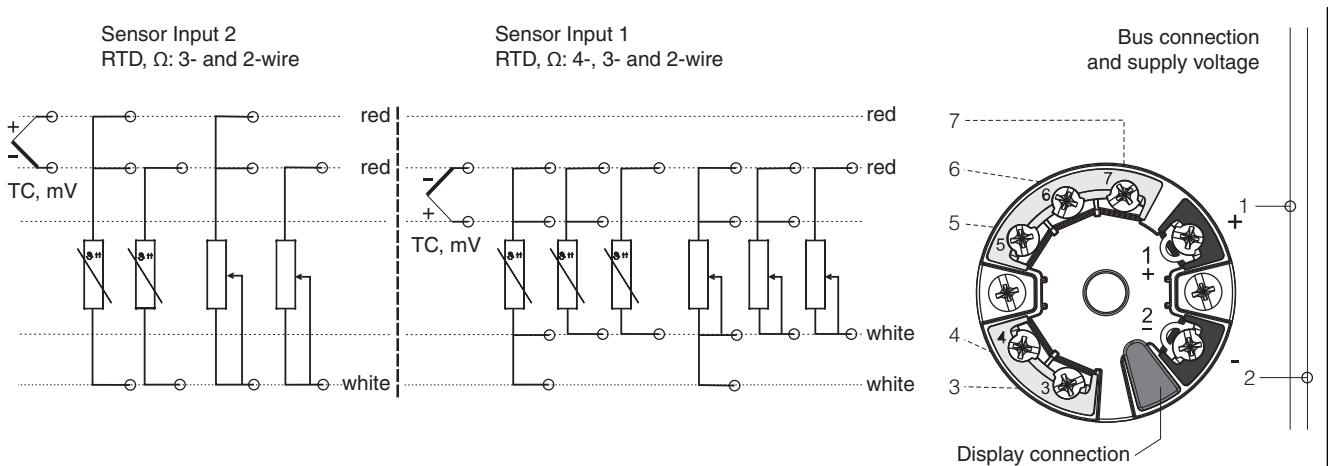
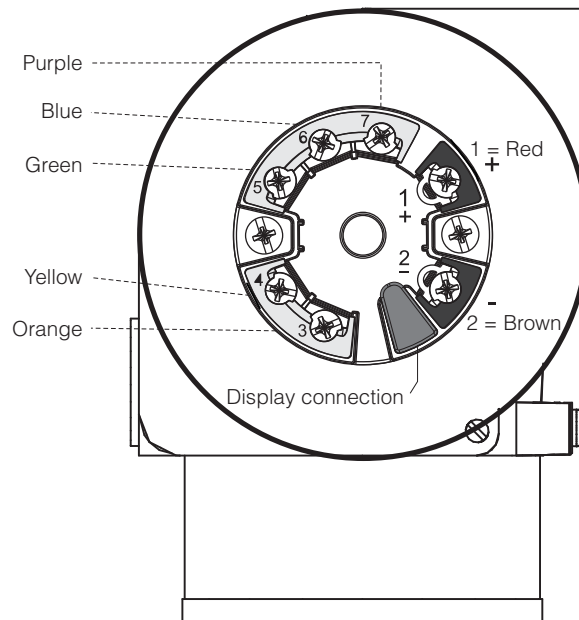

Figure 12. Dual Compartment Housing Wiring from the Terminal Block to the Module



The following connection combinations are possible when both sensor inputs are assigned:

		Sensor Input 1			
		RTD or Resistance Transmitter, 2-wire	RTD or Resistance Transmitter, 3-wire	RTD or Resistance Transmitter, 4-wire	Thermocouple (TC), Voltage Transmitter
Sensor Input 2	RTD or Resistance Transmitter, 2-Wire	OK	OK	—	OK
	RTD or Resistance Transmitter, 3-Wire	OK	OK (a)	—	OK (a)
	RTD or Resistance Transmitter, 4-Wire	—	—	—	—
	Thermocouple (TC), Voltage Transmitter	OK	OK (a)	OK (a)	OK (a)

a. These wiring types are permitted in SIL mode.

Loop Wiring

When wiring the transmitter, the supply voltage and loop load must be within specified limits. The supply output load vs. voltage relationship is:

$$R_{b \max} = (U_{b \max} - 11V) / 0.023 \text{ A (current output) and is shown in Figure 13.}$$

Any combination of supply voltage and loop load resistance in the shaded area can be used. To determine the loop load resistance (transmitter output load), add the series resistance of each component in the loop, excluding the transmitter. The power supply must be capable of supplying 23 mA of loop current.

— NOTE

The maximum voltage is 30 V dc for transmitters certified as intrinsically safe.

Figure 13. Supply Voltage and Loop Load

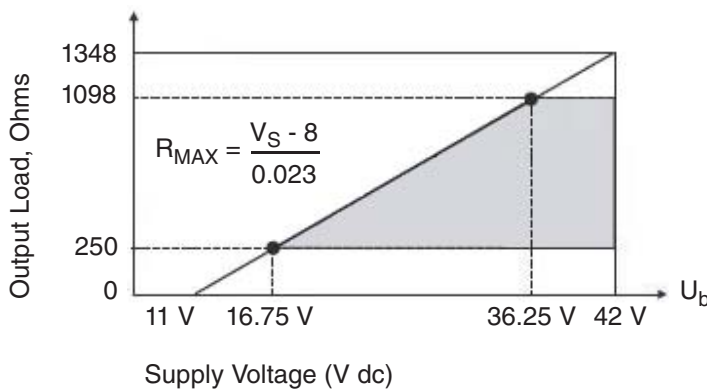

— NOTE

The transmitter will function with an output load less than 250 Ω provided that a HART Communicator or PC-based Configurator is not connected to it. Use of a HART Communicator or PC-based Configurator requires 250 Ω minimum load.

To wire one or more transmitters to a power supply, proceed with the following steps.

1. Remove the cover from the transmitter field terminals compartment.
2. Run signal wires (0.50 mm² or 20 AWG, typical) to the transmitter. Use twisted single pair to protect the 4 to 20 mA output and/or remote communications from electrical noise. Maximum recommended length for signal wires is:
 - ◆ 3050 m (10,000 ft) **using single pair cable** and adhering to requirements of HART physical layer implementation defined in HART Document HCF_SPEC-53. Use CN=1 when calculating maximum lengths.
 - ◆ 1525 m (5000 ft) in a multidrop (15 devices maximum) mode. Screened (shielded) cable could be required in some locations.

NOTE

Do not run transmitter wires in same conduit as mains (ac power) wires.

3. If shielded cable is used, earth (ground) the shield at the power supply **only**. Do not ground the shield at the transmitter.
4. If housing is used, plug any unused conduit connection with a metal plug.
5. Connect an earth (ground) wire to the earth terminal in accordance with local practice.

! CAUTION

If the signal circuit must be earthed (grounded), it is preferable to do so at the negative terminal of the dc power supply. To avoid errors resulting from earth loops or the possibility of short-circuiting groups of instruments in a loop, there should be only one earth in a loop.

6. Connect receivers (such as controllers, recorders, indicators) in series with power supply and transmitter as shown in Figure 14.
7. If a housing is used, install the cover onto the housing.
8. If wiring additional transmitters to the same power supply, repeat Steps 1 through 7 for each additional transmitter. The setup with multiple transmitters connected to a single power supply is shown in Figure 15.
9. The HART Communicator can be connected in the loop between the transmitter and the power supply as shown in the two figures below. Note that a minimum of 250 Ω must separate the power supply from the HART Communicator.

Figure 14. Transmitter Loop Wiring

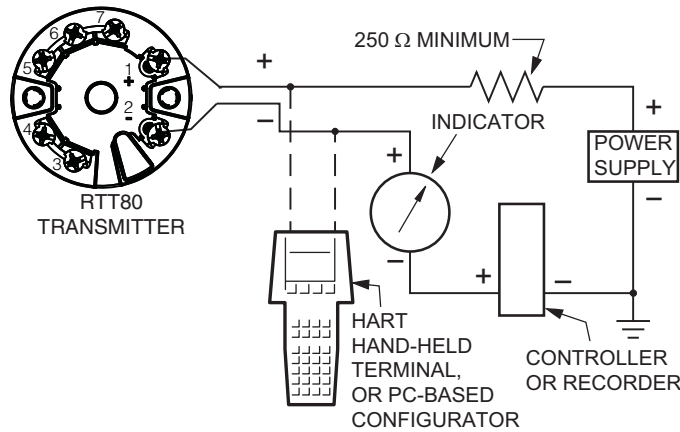
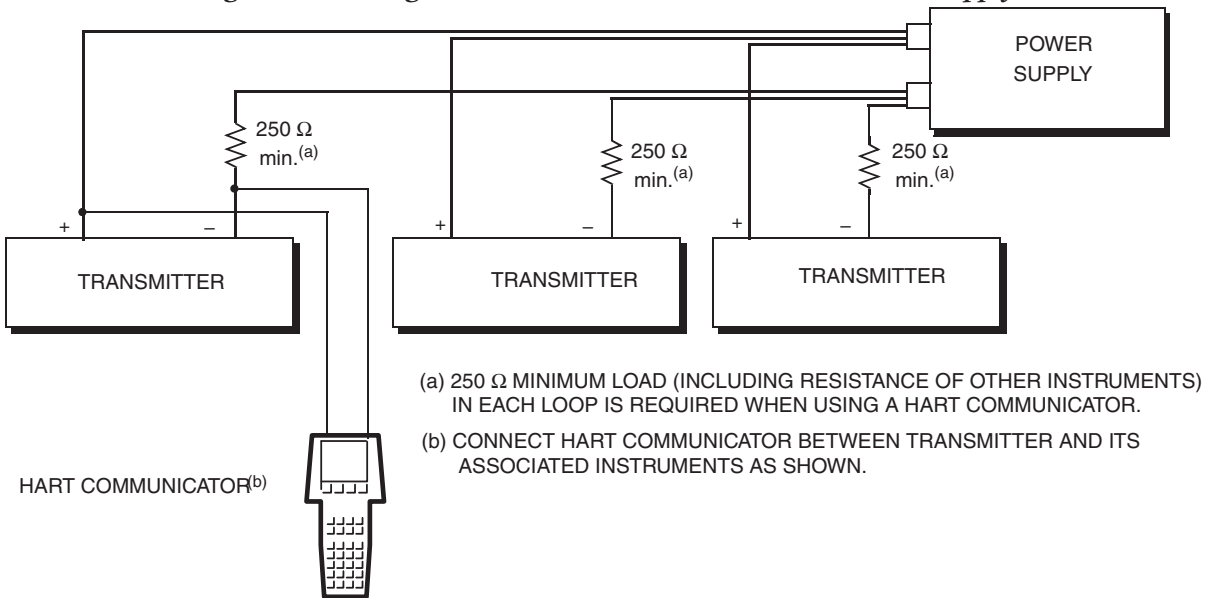

Figure 15. Wiring Several Transmitters to a Common Power Supply



Multidrop Communication

“Multidropping” refers to the connection of several transmitters to a single communications transmission line. Communications between the host computer and the transmitters takes place digitally with the analog output of the transmitter deactivated. With the HART communications protocol, up to 15 transmitters can be connected on a single twisted pair of wires or over leased telephone lines.

The application of a multidrop installation requires consideration of the update rate necessary from each transmitter, the combination of transmitter models, and the length of the transmission line. Multidrop installations are not recommended where Intrinsic Safety is a requirement. Communication with the transmitters can be accomplished with any HART compatible modem and a host implementing the HART protocol. Each transmitter is identified by a unique address (1-15) and responds to the commands defined in the HART protocol.

Figure 16 shows a typical multidrop network. Do not use this figure as an installation diagram. Contact the HART Communications Foundation, visit <http://www.hartcomm.org/>, with specific requirements for multidrop applications.

Figure 16. Typical Multidrop Network

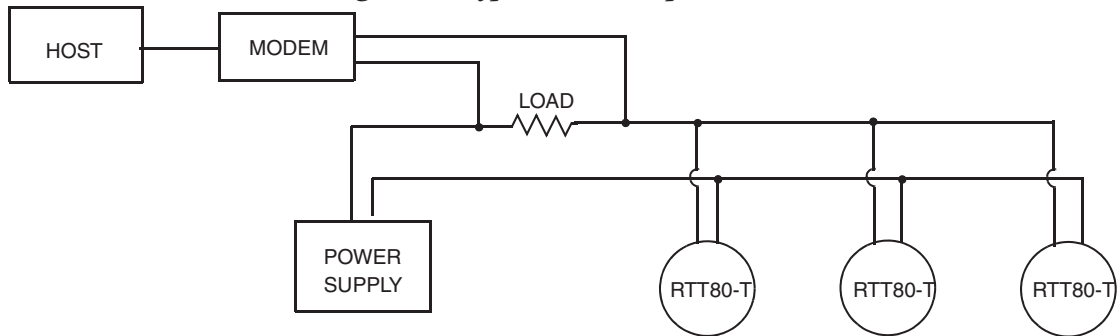

3. Operation

The RTT80 is operated as a HART compliant device. Measurement may be communicated either as point-to-point or as a multi-drop transmitter. Output may be digital using HART commands or primary value via 4 to 20 mA output.

Operation via HART 7 Protocol

With the exception of two operations that can be carried out by means of the Display DIP switches described below, the RTT80-T is operated via HART revision 7 protocol. Operation via the HART protocol can be done using a handheld HART Field Communicator, models 375 or 475, or a PC-based configurator. See Chapter 4 for details of the on-line menu accessible by means of the HART communicator.

— NOTE —

For proper operation with a HART communicator, it must contain the proper DD (Device Descriptor) file for the RTT80-T. The DD is available from Invensys Systems, Inc. or any other authorized HART Foundation source and is compatible with both the SIL and non-SIL versions of the RTT80.

A PC-based DTM (Device Type Manager) for the RTT80 is available from Invensys Systems, Inc. and is described in MI 020-520. The HART 7 RTT80 DTM is compatible with both the SIL and non-SIL versions of the RTT80.

Operation via Optional -L1 Display

Two features of the RTT80 are configured via hardware in the form of DIP switches on the optional -L1 Display. The Disp 180 DIP switch toggles the display orientation 180 degrees. The WRITE LOCK DIP switch locks all settings in the RTT80 and they remain locked even if the display is removed. If removed, the display must be re-connected in order to unlock the RTT80.

All other DIP switches are inactive when used with the RTT80-T.

Figure 17. Display DIP Switches

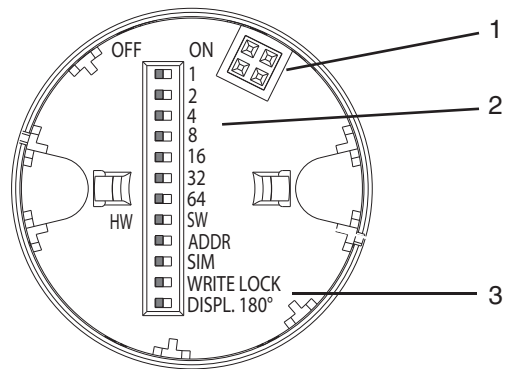

- 1 Connector to RTT80 transmitter
- 2 DIP switches 1 through 64, HW/SW, ADDR ACTIVE, SIM – Factory use only
- 3 WRITE LOCK, DISP 180° - Set to ON/OFF

4. Operating Menu and Parameter Description

The following tables list all the parameters in the “Setup”, “Diagnostics”, and “Expert” operating menus. The page reference indicates where a description of the parameter can be found in the manual.

Depending on the parameter configuration, not all submenus and parameters are available in every device. Information on this can be found in the parameter description under “Prerequisite”. The parameter groups for the Expert setup contain all the parameters of the "Setup" and "Diagnostics" operating menus, as well as other parameters that are solely reserved for experts.

Configuration in the SIL mode differs from the standard mode and is described in the Functional Safety Manual.

NOTE
For more information please refer to the Functional Safety Manual MI 020-584.

Table 8. Setup Menu

Setup →	Device tag			See page 42
	Unit			See page 42
	Sensor type 1			See page 42
	Connection type 1			See page 43
	2-wire compensation 1			See page 43
	Reference junction 1			See page 43
	RJ preset value 1			See page 43
	Sensor type 2			See page 42
	Connection type 2			See page 43
	2-wire compensation 2			See page 43
	Reference junction 2			See page 43
	RJ preset value 2			See page 43
	Assign current output (PV)			See page 44
	Lower range value			See page 44
	Upper range value			See page 44
Setup →	Advanced Setup →	Enter access code		See page 46
		Access status tooling		See page 46
		Locking status		See page 46
		Device temperature alarm		See page 46
Setup →	Advanced Setup →	Sensor →	Sensor offset 1	See page 47
			Sensor offset 2	See page 47
			Corrosion detection	See page 47
			Drift/difference mode	See page 47
			Drift/difference alarm category	See page 48
			Drift/difference alarm delay	See page 48
			Drift/difference set point	See page 48

Table 8. Setup Menu (Continued)

			Sensor switch set point	See page 48
Setup →	Advanced Setup →	Current output →	Output current	See page 49
			Measuring mode	See page 50
			Out of range category	See page 50
			Failure mode	See page 50
			Failure current	See page 50
			Current trimming 4 mA	See page 51
			Current trimming 20 mA	See page 51
Setup →	Advanced Setup →	Display →	Display interval	See page 51
			Format display	See page 52
			Value 1 display	See page 53
			Decimal places 1	See page 53
			Value 2 display	See page 54
			Decimal places 2	See page 54
			Value 3 display	See page 54
			Decimal places 3	See page 55
Setup →	Advanced Setup →	SIL →	SIL option	See page 56
			Operational state	See page 56
			Enter SIL checksum	See page 56
			Timestamp SIL configuration	See page 57
			SIL startup mode	See page 57
			SIL HART mode	See page 57
			Force safe state	See page 57
Setup →	Advanced Setup →	Administration →	Device reset	See page 58
			Define device write protection code	See page 58

Table 9. Diagnostics Menu

Diagnostics →	Actual diagnostics			See page 59
	Remedy information			See page 59
	Previous diagnostics 1			See page 59
	Operating time			See page 59
Diagnostics →	Diagnostics list →	Actual diagnostic count		See page 59
		Actual diagnostics		See page 60
		Actual diag channel		See page 60
Diagnostics →	Event logbook →	Previous diagnostics n		See page 60
		Previous diag channel n		See page 60
Diagnostics →	Device information →	Device tag		See page 61
		Serial number		See page 61
		Firmware version		See page 61
		Device name		See page 61
		Order code		See page 61
		Configuration counter		See page 62
Diagnostics →	Measured values →	Sensor value 1		See page 62
		Sensor value 2		See page 62
		Device temperature		See page 62
Diagnostics →	Measured values →	Min/max values →	Sensor n min value	See page 62
			Sensor n max value	See page 62

Table 9. Diagnostics Menu (Continued)

			Reset sensor min/mix values	See page 63
			Device temperature min.	See page 63
			Device temperature max.	See page 63
			Reset device temperature min/max	See page 63
Diagnostics →	Simulation →		Simulation current output	See page 64
			Value current output	See page 64

Table 10. Expert Menu

Expert →	Enter access code				See page 46
	Access status toolings				See page 46
	Locking status				See page 46
Expert →	System →	Unit			See page 42
		Damping			See page 65
		Alarm delay			See page 65
		Mains filter			See page 65
		Device temperature alarm			See page 65
Expert →	System →	Display →	Display interval		See page 51
			Format display		See page 52
			Value 1 display		See page 53
			Decimal places 1		See page 53
			Value 2 display		See page 54
			Decimal places 2		See page 54
			Value 3 display		See page 54
			Decimal places 3		See page 55
Expert →	System →	Administration →	Device reset		See page 58
			Define device write protection code		See page 58
Expert →	Sensor →	Sensor n (a) →	Sensor type n		See page 42
			Connection type n		See page 43
			2-wire compensation n		See page 43
			Reference junction n		See page 43
			RJ preset value		See page 43
			Sensor offset n		See page 47
			Sensor n lower limit		See page 66
			Sensor n upper limit		See page 65
			Sensor serial number		See page 66
Expert →	Sensor →	Sensor n →	Sensor trimming →	Sensor trimming	See page 67
				Sensor trimming lower value	See page 67
				Sensor trimming upper value	See page 68
				Sensor trimming min span	See page 68
Expert →	System →	Sensor n (a) →	Linearization →	Sensor n lower limit	See page 69
				Sensor n upper limit	See page 69

Table 10. Expert Menu (Continued)

				Call./v. Dusen coeff. R0, A, B C	See page 69
				Polynomial coeff. R0, A, B	See page 69
Expert →	Sensor →	Diagnostic settings →	Corrosion detection		See page 47
			Drift/difference mode		See page 47
			Drift/difference alarm category		See page 48
			Drift/difference alarm delay		See page 48
			Drift/difference set point		See page 48
			Sensor switch set point		See page 48
			Calibration counter start		See page 70
			Calibration alarm category		See page 70
			Calibration counter start value		See page 70
			Calibration countdown		See page 70
Expert →	Output →	Output current			See page 49
		Measuring mode			See page 71
		Lower range value			See page 71
		Upper range value			See page 44
		Out of range category			See page 50
		Failure mode			See page 50
		Failure current			See page 50
		Current trimming 4 mA			See page 51
		Current trimming 20 mA			See page 51
Expert →	Communication →	HART configuration →	Device tag		See page 71
			HART short tag		See page 71
			HART address		See page 71
			No of preambles		See page 71
			Configuration changed		See page 72
			Reset configuration changed flag		See page 72
Expert →	Communication →	HART info →	Device type		See page 72
			Device revision		See page 72
			HART revision		See page 72
			HART descriptor		See page 72
			HART message		See page 73
			Hardware revision		See page 73
			RevSW		See page 73
			HART date code		See page 73
Expert →	Communication →	HART output →	Assign current output (PV)		See page 74
			PV		See page 74
			Assign SV		See page 74
			SV		See page 74
			Assign TV		See page 74
			TV		See page 75
			Assign QV		See page 75
			QV		See page 75
Expert →	Communication →	Burst configuration →	Burst mode		See page 75
			Burst command		See page 76
			Burst variable 0-3		See page 76

Table 10. Expert Menu (Continued)

			Burst trigger mode		See page 77
			Burst trigger level		See page 77
			Burst min period		See page 77
			Burst max period		See page 78
Expert →	Diagnostics →		Actual diagnostics		See page 59
			Remedy information		See page 59
			Previous diagnostics 1		See page 59
			Operating time		See page 59
Expert →	Diagnostics →	Diagnostics list →	Actual diagnostics count		See page 59
			Actual diagnostics		See page 60
			Actual diag channel		See page 60
Expert →	Diagnostics →	Event logbook →	Previous diagnostics n		See page 60
			Previous diag channel		See page 60
Expert →	Diagnostics →	Device information →	Device tag		See page 42
			Serial number		See page 61
			Firmware version		See page 61
			Device name		See page 61
			Order code		See page 61
			Extended order code		See page 78
			Extended order code 2		See page 78
			Extended order code 3		See page 78
			ENP version		See page 78
			Device revision		See page 78
			Manufacturer ID		See page 79
			Manufacturer		See page 79
			Hardware revision		See page 79
			Configuration counter		See page 62
Expert →	Diagnostics →	Measured values →	Sensor n value		See page 62
			Sensor n raw value		See page 79
			Device temperature		See page 62
Expert →	Diagnostics →	Measured values →	Min/max values →	Sensor n min value	See page 62
				Sensor n max value	See page 62
				Reset sensor min/max values	See page 63
				Device temperature min.	See page 63
				Device temperature max.	See page 63
				Reset device temperature min/max	See page 63
Expert →	Diagnostics →	Simulation →	Simulation current output		See page 64
			Value current output		See page 64

a. n = number of sensor inputs (1 and 2)

Setup Menu

This menu contains all the parameters that are needed to configure the basic settings of the device. The transmitter can be put into operation with this limited parameter set.

— NOTE

n = Stands for the number of sensor inputs (1 and 2)

Device tag	
Navigation	Setup → Device tag Diagnostics → Device information → Device tag Expert → Diagnostics → Device information → Device tag
Description	Use this function to enter a unique name for the measuring point so it can be identified quickly within the plant. The name is displayed in the header of the plug-in display.
User entry	Max. 32 characters, such as letters, numbers or special characters (e.g. @, %, /)
Factory setting	-none-

Unit	
Navigation	Setup → Unit Expert → System → Unit
Description	Use this function to select the engineering unit for all the measured values.
Options	<ul style="list-style-type: none"> ▶ °C ▶ °F ▶ K ▶ °R ▶ Ohm ▶ mV
Factory setting	°C

Sensor type n	
Navigation	Setup → Sensor type n Expert → Sensor → Sensor n → Sensor type n
Description	<p>Use this function to select the sensor type for the sensor input in question.</p> <ul style="list-style-type: none"> ▶ Sensor type 1: settings for sensor input 1 ▶ Sensor type 2: settings for sensor input 2 <p>NOTE: Please observe the terminal assignment when connecting the individual sensors. In the case of 2-channel operation, the possible connection options also have to be observed.</p>
Options	A list of all the possible sensor types is provided in the 'Technical data' section.
Factory setting	Sensor type 1: Pt100 IEC751 Sensor type 2: No sensor

Connection type n	
Navigation	Setup → Connection type n Expert → Sensor → Sensor n → Connection type n
Prerequisite	An RTD sensor must be specified as the sensor type.
Description	Use this function to select the connection type for the sensor.
Options	<ul style="list-style-type: none"> ▶ Sensor 1 (connection type 1): 2-wire, 3-wire, 4-wire ▶ Sensor 2 (connection type 2): 2-wire, 3-wire
Factory setting	<ul style="list-style-type: none"> ▶ Sensor 1 (connection type 1): 4-wire ▶ Sensor 2 (connection type 2): 2-wire

2-wire compensation n	
Navigation	Setup → 2-wire compensation n Expert → Sensor → Sensor n → 2-wire compensation n
Prerequisite	An RTD sensor with a 2-wire connection type must be specified as the sensor type.
Description	Use this function to specify the resistance value for two-wire compensation in RTDs.
Options	0 to 30 Ohm
Factory setting	0

Reference junction n	
Navigation	Setup → Reference junction n Expert → Sensor → Sensor n → Reference junction n
Prerequisite	A thermocouple (TC) sensor must be selected as the sensor type.
Description	Use this function to select reference junction measurement for temperature compensation of thermocouples (TC). NOTE: <ul style="list-style-type: none"> ▶ If Preset value is selected, the compensation value is specified via the RJ preset value parameter. ▶ Temperature measured must be configured for channel 2 if Measured value sensor 2 is selected.
Options	<ul style="list-style-type: none"> ▶ No compensation: no temperature compensation is used. ▶ Internal measurement: the internal reference junction temperature is used. ▶ Preset value: a fixed preset value is used. ▶ Measured value sensor 2: the measured value of sensor 2 is used. <p>NOTE: It is not possible to selected the Measured value sensor 2 option for the Reference junction 2 parameter.</p>
Factory setting	Internal measurement

RJ preset value n	
Navigation	Setup → RJ preset n Expert → Sensor → Sensor n → RJ preset n
Prerequisite	The Preset value parameter must be set if the Reference junction n option is selected.
Description	Use this function to define the fixed preset value for temperature compensation.
User entry	-50 to +85 °C
Factory setting	0.00

Assign current output (PV)	
Navigation	Setup → Assign current output (PV) Expert → Communication → HART output → Assign current output (PV)
Description	Use this function to assign a measured variable to the primary HART® value (PV).
Options	<ul style="list-style-type: none"> ▶ Sensor 1 (measured value) ▶ Sensor 2 (measured value) ▶ Average of the two measured values: 0.5 x (SV1+SV2) ▶ Difference between sensor 1 and sensor 2: SV1-SV2 ▶ Sensor 1 (backup sensor 2): If sensor 1 fails, the value of sensor 2 automatically becomes the primary HART value (PV): sensor 1 (OR sensor 2) ▶ Sensor switching: If the value exceeds the configured threshold value T for sensor 1, the measured value of sensor 2 becomes the primary HART® value (PV). The system switches back to sensor 1 if the measured value of sensor 1 is at least 2 K below T: sensor 1 (sensor 2, if sensor 1 > T). ▶ Average: 0.5 x (SV1+SV2) with backup (measured value of sensor 1 or sensor 2 in the event of a sensor error in the other sensor) <p>NOTE: The threshold value can be set with the Sensor switching limit value parameter (see page 48). With temperature-dependent switching, it is possible to combine 2 sensors that offer advantages in different temperature ranges.</p>
Factory setting	Sensor 1

Lower range value	
Navigation	Setup → Lower range value Expert → Output → Lower range value
Description	Use this function to assign a measured value to the current value 4 mA. NOTE: The limit value that can be set depends on the sensor type used in the Sensor type parameter (see page 42) and the measured variable assigned in the Assign current output (PV) parameter.
User entry	Depends on the sensor type and the setting for Assign current output (PV).
Factory setting	0

Upper range value	
Navigation	Setup → Upper range value Expert → Output → Upper range value
Description	Use this function to assign a measured value to the current value 20 mA. NOTE: The limit value that can be set depends on the sensor type used in the Sensor type parameter (see page 42) and the measured variable assigned in the Assign current output (PV) parameter.
User entry	Depends on the sensor type and the setting for Assign current output (PV).
Factory setting	100

Advanced Setup Submenu

Corrosion Monitoring

Sensor connection cable corrosion can lead to false measured value readings. Therefore the unit offers the possibility of recognizing any corrosion before a measured value is affected. Corrosion monitoring is only possible for RTDs with a 4-wire connection and thermocouples.

Drift/Difference Mode

If two sensors are connected and the measured values differ by a specified value, a status signal is generated as a diagnostic event. The drift/difference monitoring function can be used to verify the correctness of the measured values and for mutual monitoring of the connected sensors.

Drift/difference monitoring is enabled with the **Drift/difference mode** parameter. A distinction is made between two specific modes. If the **In band** option is selected ($ISV1-SV2I < \text{drift/difference set point}$), a status message is issued if the value drops below the set point, or if the value exceeds the set point if the **Out band (drift) option** is selected ($ISV1-SV2I > \text{drift/difference set point}$).

Table 11. Procedure for Configuring the Drift/Difference Mode

1. Start
↓
2. For drift/difference monitoring, select Out band for drift detection and In band for difference monitoring.
↓
3. Set the alarm category for drift/difference to Out of specification (S) , Maintenance required (M) , or Failure (F) as required.
↓
4. Set the set point for drift/difference monitoring to the desired value.
↓
5. End

Figure 18. Drift/difference Mode

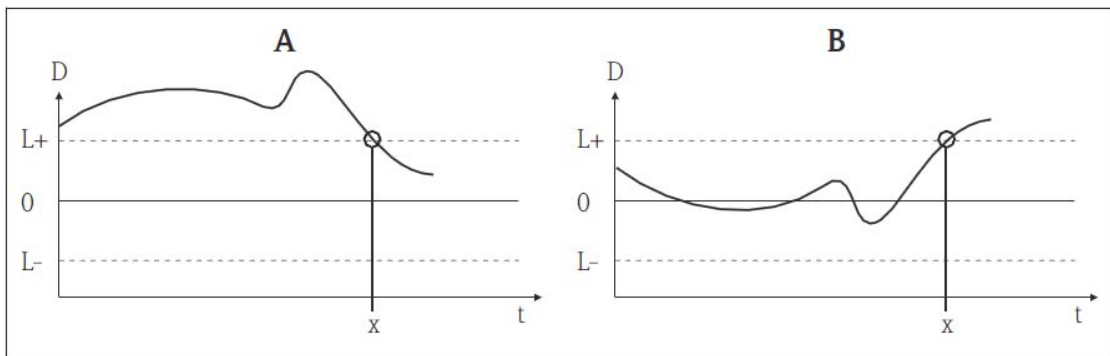

Key:

- A Value under range
- B Value over range
- D Drift
- L+ Upper (+) set point
- L- Lower (-) set point
- t time
- x Diagnostics event, status signal is generated

Enter access code	
Navigation	Setup → Advanced setup → Enter access code Expert → Enter access code
Description	Use this function to enable the service parameters via the operating tool. If an incorrect access code is entered, the user retains his current access authorization. NOTE: If a value is entered that is not to equal to the access code, the parameter is automatically set to 0. The service parameters should only be modified by the service organization.
User entry	0 to 9999
Factory setting	0

Access status tooling	
Navigation	Setup → Advanced setup → Access status tooling Expert → Access status tooling
Description	Use this function to show access authorization to the parameters.
Additional information	If additional write protection is active, this restricts the current access authorization even further. The write protection status can be viewed via the Locking status parameter.
User entry	<ul style="list-style-type: none"> ▶ Operator ▶ Service
Factory setting	Operator

Locking status	
Navigation	Setup → Advanced setup → Locking status Expert → Locking status
Description	Use this function to view the device locking status. The DIP switch for hardware locking is fitted on the display module. When write protection is activated, write access to the parameters is disabled.

Device temperature alarm	
Navigation	Setup → Advanced setup → Device temperature alarm
Description	Use this function to select the category (status signal) as to how the device reacts when the electronics temperature of the transmitter exceeds or falls below the limit value < -40°C (-40 °F) or > +85 °C (+185 °F).
Options	<ul style="list-style-type: none"> ▶ Off ▶ Out of specification (S) ▶ Failure (F)
Factory setting	Out of specification (S)

Sensor Submenu

Sensor offset n	
	NOTE: n = Stands for the number of sensor inputs (1 and 2)
Navigation	Setup → Advanced setup → Sensor → Sensor offset n Expert → Sensor → Sensor n → Sensor offset n
Description	Use this function to set the zero point correction (offset) of the sensor measured value. The value indicated is added to the measured value.
User entry	-10.0 to +10.0
Factory setting	0.0

Corrosion detection	
Navigation	Setup → Advanced setup → Sensor → Corrosion detection Expert → Sensor → Diagnostics settings → Corrosion detection
Description	Use this function to select the category (status signal) which is displayed when corrosion is detected in the sensor connection cables. NOTE: Only possible for RTD sensors with 4-wire connection and thermocouples (TC).
User entry	<ul style="list-style-type: none"> ▶ Maintenance required (M) ▶ Failure (F)
Factory setting	Maintenance required (M)

Drift/difference mode	
Navigation	Setup → Advanced setup → Sensor → Drift/difference mode Expert → Sensor → Diagnostic settings → Drift/difference mode
Description	Use this function to choose whether the device reacts to the drift/difference limit value being exceeded or undershot. NOTE: Can only be selected for 2-channel operation.
Additional information	<ul style="list-style-type: none"> ▶ If the Out band (drift) option is selected, a status signal is displayed if the absolute value for the differential value exceeds the drift/difference set point ▶ If the In band option is selected, a status signal is displayed if the absolute value for the differential value drops below the drift/difference set point.
Options	<ul style="list-style-type: none"> ▶ Off ▶ Out band (drift) ▶ In band
Factory setting	Off

Drift/difference alarm category	
Navigation	Setup → Advanced setup → Sensor → Drift/difference alarm category Expert → Sensor → Diagnostic settings → Drift/difference alarm category
Prerequisite	The Drift/difference mode parameter must be activated with the Out band (drift) or In band option.
Description	Use this function to select the category (status signal) as to how the device reacts when a drift/difference is detected between sensor 1 and sensor 2.
User entry	<ul style="list-style-type: none"> ▶ Out of specification (S) ▶ Maintenance required (M) ▶ Failure (F)
Factory setting	Maintenance required (M)

Drift/difference alarm delay	
Navigation	Setup → Advanced setup → Sensor → Drift/difference alarm delay Expert → Sensor → Diagnostic settings → Drift/difference alarm delay
Prerequisite	The Drift/difference mode parameter must be activated with the Out band (drift) or In band option (see page 47).
Description	Alarm delay for drift detection monitoring. NOTE: Useful for example in the event of different thermal mass ratings for the sensors in conjunction with a high temperature gradient in the process.
User entry	0 to 255 s
Factory setting	0 s

Drift/difference set point	
Navigation	Setup → Advanced setup → Sensor → Drift/difference set point Expert → Sensor → Diagnostic settings → Drift/difference set point
Prerequisite	The Drift/difference mode parameter must be activated with the Out band (drift) or In band option.
Description	Use this function to configure the maximum permissible measure value deviation between sensor 1 and sensor 2 which results in drift/difference detection.
User entry	0.1 to 999.0 K (0.18 to 1798.2 °F)
Factory setting	999.0

Sensor switch set point	
Navigation	Setup → Advanced setup → Sensor → Sensor switch set point Expert → Sensor → Diagnostic settings → Sensor switch set point
Description	Use this function to set the threshold value for sensor switching (see page 44).
Additional information	The threshold value is relevant if the sensor switching function is assigned to a HART® variable (PV, SV, TV, QV).
User entry	Depends on the sensor types selected.
Factory setting	850 °C

Current Output Submenu

Adjustment of the Analog Output (4 to 20 mA Current Trimming)

Current trimming is used to compensate the analog output (D/A conversion). Here, the output current of the transmitter must be adapted so that it suits the value expected at the higher-order system.

— NOTE —

Current trimming does not affect the digital HART® value. This can cause the measured value shown on the plug-in display to differ from the value displayed in the higher-order system.

- The digital measured values can be adapted with the sensor trimming parameter in the menu Expert → Sensor → Sensor trimming.

Table 12. Procedure for Adjusting Analog Output

1. Start
↓
2. Install an accurate amperemeter (more accurate than the transmitter) in the current loop.
↓
3. Switch on current output simulation and set the simulation value to 4 mA.
↓
4. Measure the loop current with the amperemeter and make a note of the value.
↓
5. Set the simulation value to 20 mA.
↓
6. Measure the loop current with the amperemeter and make a note of the value.
↓
7. Enter the current values determined as adjustment values in the Current trimming 4 mA/20 mA parameters.
↓
8. End

Output current	
Navigation	Setup → Advanced setup → Current output → Output current Expert → Output → Output current
Description	Use this function to view the calculated output current in mA.

Measuring mode	
Navigation	Setup → Advanced setup → Current output → Measuring mode Expert → Output → Measuring mode
Description	Enables the inversion of the output signal.
Additional information	<ul style="list-style-type: none"> ▶ Standard The output current increases with increasing temperatures ▶ inverted The output current decreases with increasing temperatures
Options	<ul style="list-style-type: none"> ▶ Standard ▶ inverted
Factory setting	Standard

Out of range category	
Navigation	Setup → Advanced setup → Current output → Out of range category Expert → Output → Out of range category
Description	Use this function to select the category (status signal) as to how the device reacts when the value is outside the set measuring range.
Options	<ul style="list-style-type: none"> ▶ Out of specification (S) ▶ Maintenance required (M) ▶ Failure (F)
Factory setting	Maintenance required (M)

Failure mode	
Navigation	Setup → Advanced setup → Current output → Failure mode Expert → Output → Failure mode
Description	Use this function to select the signal on alarm level of the current output in the event of an error.
Additional information	If Max. is selected, the signal on alarm level is specified using the Failure current parameter.
Options	<ul style="list-style-type: none"> ▶ Min. ▶ Max.
Factory setting	Max.

Failure current	
Navigation	Setup → Advanced setup → Current output → Failure current Expert → Output → Failure current
Prerequisite	The Max. option is enabled in the Failure mode parameter.
Description	Use this function to set the value the current output adopts in an alarm condition.
User entry	21.5 to 23.0 mA
Factory setting	22.5

Current trimming 4 mA	
Navigation	Setup → Advanced setup → Current output → Current trimming 4 mA Expert → Output → Current trimming 4 mA
Description	Use this function to set the correction value for the current output at the start of the measuring range at 4 mA (see page 49).
User entry	3.85 to 4.15 mA
Factory setting	4 mA

Current trimming 20 mA	
Navigation	Setup → Advanced setup → Current output → Current trimming 20 mA Expert → Output → Current trimming 20 mA
Description	Use this function to set the correction value for the current output at the end of the measuring range at 20 mA (see page 49).
User entry	19.850 to 20.15 mA
Factory setting	20.000 mA

Display Submenu

The settings for displaying the measured value on the optional plug-in display (only for head transmitter) are made in the "Display" menu.

NOTE

These settings do not have any effect on the output values of the transmitter. They are only used to configure how information is shown on the display.

Display interval	
Navigation	Setup → Advanced setup → Display → Display interval Expert → System → Display → Display interval
Description	Use this function to set the length of time the measured values are displayed if the values alternate on the display. The display only alternates between values if more than one measured value is defined. NOTE: <ul style="list-style-type: none"> ▶ The Value 1 display - Value 3 display parameters are used to specify what measured values are shown on the display (see page 53). ▶ The display format of the displayed measured values is specified using the Format display parameter.
User entry	4 to 20 s
Factory setting	4 s

Format display	
Navigation	Setup → Advanced setup → Display → Format display Expert → System → Display → Format display
Description	Use this function to select how the measured value is shown on the local display. The display format Measured value or Measured value with bar graph can be configured.
User entry	<ul style="list-style-type: none"> ▶ Value only ▶ Value + Bargraph
Factory setting	Value only
Additional information	See Figure 19 and Figure 20

Figure 19. Value only

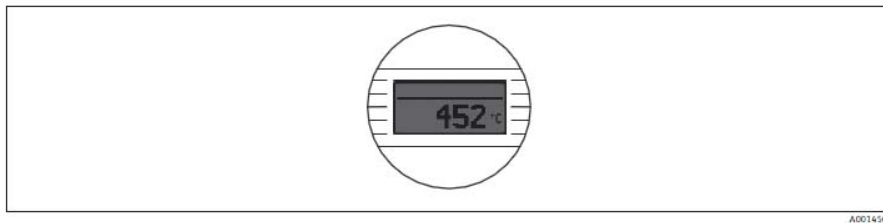

A0014564

Figure 20. Value + Bargraph

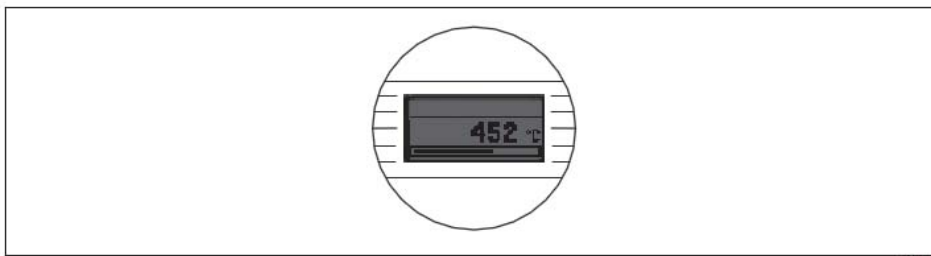

A0014565

The optional display contains several pieces of information as illustrated in Figure 21 below:

Figure 21. Display Information

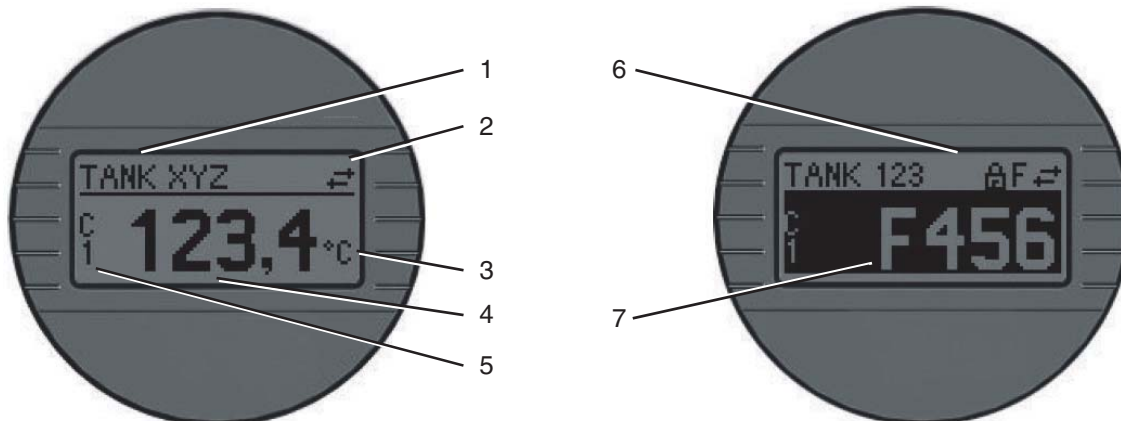

Table 13. Display Information

Display	Information
1	Tag
2	Communication icon
3	Engineering unit
4	Measured value
5	Channel of measured value (S1, S2, DT, PV, I, %)
6	Configuration locked
7	Status (fault communication) <ul style="list-style-type: none"> ▶ S = Out of specification – Device is operating outside of its technical specifications ▶ C = Service mode – Device is in service mode (i.e. device in simulation) ▶ M = Maintenance required – Measurement is valid but a monitored diagnostic parameter indicates that maintenance is needed ▶ F = Fault – Measurement is not valid. The “F” symbol is appended by a diagnostic code (See “Maintenance” section)

Value 1 display	
Navigation	Setup → Advanced setup → Display → Value 1 display Expert → System → Display → Value 1 display
Description	Use this function to select one of the measured values to be shown on the local display. NOTE: The Format display parameter is used to specify how the measured values are displayed (see page 52).
Options	<ul style="list-style-type: none"> ▶ Process value ▶ Sensor 1 ▶ Sensor 2 ▶ Output current ▶ Percent of range ▶ Device temperature
Factory setting	Process value

Decimal places 1	
Navigation	Setup → Advanced setup → Display → Decimal places 1 Expert → System → Display → Decimal places 1
Prerequisite	A measured value is specified in the Value 1 display parameter (see page 53).
Description	Use this function to select the number of decimal places displayed for the display value. This setting does not affect the accuracy of the device for measuring or calculating the value. NOTE: If Automatic is selected, the maximum possible number of decimal places is always shown on the display.
Options	<ul style="list-style-type: none"> ▶ x ▶ x.x ▶ x.xx ▶ x.xxx ▶ x.xxxx ▶ Automatic
Factory setting	Automatic

Value 2 display	
Navigation	Setup → Advanced setup → Display → Value 2 display Expert → System → Display → Value 2 display
Description	Use this function to select one of the measured values to be shown on the local display. NOTE: The Format display parameter is used to specify how the measured values are displayed.
Options	<ul style="list-style-type: none"> ▶ Off ▶ Process value ▶ Sensor 1 ▶ Sensor 2 ▶ Output current ▶ Percent of range ▶ Device temperature
Factory setting	Off

Decimal places 2	
Navigation	Setup → Advanced setup → Display → Decimal places 2 Expert → System → Display → Decimal places 2
Prerequisite	A measured value is specified in the Value 2 display parameter.
Description	Use this function to select the number of decimal places displayed for the display value. This setting does not affect the accuracy of the device for measuring or calculating the value. NOTE: If Automatic is selected, the maximum possible number of decimal places is always shown on the display.
Options	<ul style="list-style-type: none"> ▶ x ▶ x.x ▶ x.xx ▶ x.xxx ▶ x.xxxx ▶ Automatic
Factory setting	Automatic

Value 3 display	
Navigation	Setup → Advanced setup → Display → Value 3 display Expert → System → Display → Value 3 display
Description	Use this function to select one of the measured values to be shown on the local display. NOTE: The Format display parameter is used to specify how the measured values are displayed.
Options	<ul style="list-style-type: none"> ▶ Off ▶ Process value ▶ Sensor 1 ▶ Sensor 2 ▶ Output current ▶ Percent of range ▶ Device temperature
Factory setting	Off

Decimal places 3	
Navigation	Setup → Advanced setup → Display → Decimal places 3 Expert → System → Display → Decimal places 3
Prerequisite	A measured value is specified in the Value 3 display parameter.
Description	Use this function to select the number of decimal places displayed for the display value. This setting does not affect the accuracy of the device for measuring or calculating the value. NOTE: If Automatic is selected, the maximum possible number of decimal places is always shown on the display.
Options	<ul style="list-style-type: none"> ▶ x ▶ x.x ▶ x.xx ▶ x.xxx ▶ x.xxxx ▶ Automatic
Factory setting	Automatic

SIL Submenu

NOTE

This menu only appears if the device was ordered with the 'SIL mode' option. The SIL option parameter indicates whether the device can be operated in the SIL mode. To enable the SIL mode for the device, menu-guided operation for **Enable SIL** must be performed.

NOTE

A detailed description is provided in the Functional Safety Manual **MI 020-584**

SIL option	
Navigation	Setup → Advanced setup → SIL option
Description	Indicates whether the device has been ordered with SIL certification. SIL certificate of the device. NOTE: The SIL option is required to operate the device in the SIL mode.
Options	<ul style="list-style-type: none"> ▶ No ▶ Yes
Factory setting	No

Operational state	
Navigation	Setup → Advanced setup → SIL → Operational state
Description	Displays the device operational state in the SIL mode.
Options	<ul style="list-style-type: none"> ▶ Checking SIL option ▶ Startup normal mode ▶ Wait for checksum ▶ Self diagnostic ▶ Normal mode ▶ Download active ▶ SIL mode active ▶ Safe para start ▶ Safe param running ▶ Save parameter values ▶ Parameter check ▶ Reboot pending ▶ Reset checksum ▶ Safe state - Active ▶ Download verification ▶ Upload active ▶ Safe state - Passive ▶ Safe state - Panic <p>NOTE: If the device is restarted with the setting SIL startup mode → Not active, Wait for checksum appears in this parameter. The SIL checksum must be entered manually here.</p>
Factory setting	Checking SIL option

Enter SIL checksum	
Navigation	Setup → Advanced setup → SIL → Enter SIL checksum
Description	Use this function to enter the SIL checksum during safe parameterization and startup in conjunction with the parameter setting " SIL startup mode → Not active ". NOTE: If the parameter setting is " SIL startup mode → Not active " and the value '0' is entered, automatic startup is aborted and the SIL settings are discarded.
User entry	0 to 65535
Factory setting	0

Timestamp SIL configuration	
Navigation	Setup → Advanced setup → SIL → Timestamp SIL configuration
Description	Use this function to enter the date and time when safe parameterization has been completed and the SIL checksum has been calculated. NOTE: The date and time must be entered manually. This information is not generated automatically by the device.
User entry	DD.MM.YYYY hh:mm
Factory setting	0

SIL startup mode	
Navigation	Setup → Advanced setup → SIL → SIL startup mode
Description	Setting for repeated automatic device startup in the SIL mode, e.g. after a power-cycle. NOTE: The Not active setting requires the user to enter the SIL checksum manually in order to be able to start the device again in SIL mode.
Options	<ul style="list-style-type: none"> ▶ Not active ▶ Active
Factory setting	Not active

SIL HART mode	
Navigation	Setup → Advanced setup → SIL → SIL HART mode
Description	Setting for HART® communication in the SIL mode. The HART not active setting disables HART® communication in the SIL mode (only 4 to 20 mA communication is active).
Options	<ul style="list-style-type: none"> ▶ HART not active ▶ HART active
Factory setting	HART active

Force safe state	
Navigation	Setup → Advanced setup → SIL → Force safe state
Prerequisite	The Operational state parameter displays SIL mode active .
Description	During SIL proof testing this parameter is used to test error detection and the safe state of the device. NOTE: A detailed description of SIL proof testing is provided in the Functional Safety Manual MI 020-584.
Options	<ul style="list-style-type: none"> ▶ On ▶ Off
Factory setting	Off

Administration Submenu

Device reset	
Navigation	Setup → Advanced setup → Administration → Device reset Expert → System → Device reset
Description	Use this function to reset the device configuration - either entirely or in part - to a defined state.
Options	<ul style="list-style-type: none"> ▶ Not active No action is executed and the user exits the parameter. ▶ To factory defaults All the parameters are reset to the factory setting. ▶ To delivery settings All the parameters are reset to the order configuration. The order configuration can differ from the factory setting if customer-specific parameter values were defined when the device was ordered. ▶ Restart device The device is restarted but the device configuration remains unchanged.
Factory setting	Not active

Define device write protection code	
Navigation	Setup → Advanced setup → Administration → Device device write protection code Expert → System → Device device write protection code
Description	Sets a write protection code for the device. NOTE: If the code is programmed into the device firmware it is saved in the device and the operating tool displays the value 0 so that the defined write protection code is not openly displayed for viewing.
User entry	0 to 9999
Factory setting	0 NOTE: If the device is delivered with this factory setting the device write protection is not active.
Additional information	<ul style="list-style-type: none"> ▶ Activating device write protection: device write protection is activated via the software by entering a 4-digit code in the Enter access code parameter. This code and the defined write protection code may not be the same! ▶ Deactivating device write protection: if device write protection is activated, enter the defined write protection code in the Enter access code parameter. ▶ Once the device has been reset to the factory setting or the order configuration, the defined write protection code is no longer valid. The code adopts the factory setting (= 0). ▶ Hardware write protection (DIP switches) is active: <ul style="list-style-type: none"> ▶ Hardware write protection has priority over the software write protection described here. ▶ No value can be entered in the Enter access code parameter. The parameter is a read only parameter. ▶ Device write protection via software can only be defined and activated if hardware write protection via the DIP switches is disabled.

Diagnostics Menu

All the information that describes the device, the device status and the process conditions can be found in this group.

Actual diagnostics 1	
Navigation	Diagnostics → Actual diagnostics Expert → Diagnostics → Actual diagnostics 1
Description	Use this function to display the current diagnostics message. If two or more messages occur simultaneously, the message with the highest priority is shown on the display.
Display	Symbol for event behavior and diagnostic event.
Additional information	Example for display format: F261-Electronics modules

Remedy information	
Navigation	Diagnostics → Remedy information Expert → Diagnostics → Remedy information
Description	Use this function to display the remedial action to be taken for the current diagnostics message.

Previous diagnostics 1	
Navigation	Diagnostics → Previous diagnostics 1 Expert → Diagnostics → Previous diagnostics 1
Description	Use this function to display the last diagnostics message with the highest priority.
Display	Symbol for event behavior and diagnostic event.
Additional information	Example for display format: F261-Electronics modules

Operating time	
Navigation	Diagnostics → Operating time Expert → Diagnostics → Operating time
Description	Use this function to display the length of time the device has been in operation.
Display	Hours (h)

Diagnostic List Submenu

Up to 3 diagnostic messages currently pending are displayed in this submenu. If more than 3 messages are pending, the messages with the highest priority are shown on the display.

Actual diagnostics count	
Navigation	Diagnostics → Diagnostics list → Actual diagnostics count Expert → Diagnostics → Diagnostics list → Actual diagnostics count
Description	Use this function to display the number of diagnosis messages currently pending in the device.

Actual diagnostics	
Navigation	Diagnostics → Diagnostics list → Actual diagnostics Expert → Diagnostics → Diagnostics list → Actual diagnostics
Description	Use this function to display the current diagnostics messages with the highest priority to the third-highest priority.
Display	Symbol for event behavior and diagnostic event.
Additional information	Example for display format: F261-Electronics modules

Actual diag channel	
Navigation	Diagnostics → Diagnostics list → Actual diag channel Expert → Diagnostics → Diagnostics list → Actual diag channel
Description	Use this function to display the sensor input to which the diagnostics message refers.
Display	<ul style="list-style-type: none"> ▶ Sensor 1 ▶ Sensor 2 ▶ -----

Event Logbook Submenu

Previous diagnostics n	
	NOTE: n = Number of diagnostic messages (n = 1 to 5)
Navigation	Diagnostics → Events Logbook → Previous diagnostics n Expert → Diagnostics → Diagnostics list → Previous diagnostics n
Description	Use this function to display the diagnostics messages that occurred in the past. The last 5 messages are listed in chronological order.
Display	Symbol for event behavior and diagnostic event.
Additional information	Example for display format: F261-Electronics modules

Previous diag channel	
Navigation	Diagnostics → Events Logbook → Previous diag channel Expert → Diagnostics → Diagnostics list → Previous diag channel
Description	Use this function to display the possible sensor input to which the diagnostics message refers.
Display	<ul style="list-style-type: none"> ▶ Sensor 1 ▶ Sensor 2 ▶ -----

Device Information Submenu

Device tag	
Navigation	Setup → Device tag Diagnostics → Device information → Device tag Expert → Diagnostics → Device information → Device tag
For details, see “Device tag” on page 42.	

Serial number	
Navigation	Diagnostics → Device information → Serial number Expert → Diagnostics → Device information → Serial number
Description	Use this function to display the serial number of the device. It can also be found on the nameplate. NOTE: Uses of the serial number ▶ To identify the measuring device quickly
Display	Max. 11-digit character string comprising letters and numbers

Firmware version	
Navigation	Diagnostics → Device information → Firmware version Expert → Diagnostics → Device information → Firmware version
Description	Use this function to view the device firmware version installed.
Display	Max. 6-digit character string in the format xx.yy.zz

Device name	
Navigation	Diagnostics → Device information → Device name Expert → Diagnostics → Device information → Device name
Description	Displays the device name. It can also be found on the nameplate.

Order code	
Navigation	Diagnostics → Device information → Order code Expert → Diagnostics → Device information → Order code
Description	Use this function to display the order code of the device. It can also be found on the nameplate. The order code is generated from the extended order code, which defines all the device features of the product structure. In contrast, the device features cannot be read directly from the order code. NOTE: Uses of the order code ▶ To order an identical spare device. ▶ To identify the device quickly and easily, e.g. when contacting the manufacturer.

Configuration counter	
Navigation	Diagnostics → Device information → Configuration counter Expert → Diagnostics → Device information → Configuration counter
Description	Use this function to display the counter reading for changes to device parameters. NOTE: Static parameters, whose values change during optimization or configuration, cause this parameter to increment by 1. This support parameter version management. If several parameters change, e. g. due to loading of parameters from FieldCare, etc. in the device, the counter can show a higher value. The counter cannot be reset and is also not reset to the default value when the device is reset. If the counter overflows, (16 bit), it starts again at 1.

Measured Values Submenu

Sensor n value	
	NOTE: n = Stands for the number of sensor inputs (1 and 2)
Navigation	Diagnostics → Measured values → Sensor n value Expert → Diagnostics → Measured values → Sensor n value
Description	Use this function to display the current measured value at the sensor input.

Device temperature	
Navigation	Diagnostics → Measured values → Device temperature Expert → Diagnostics → Measured values → Device temperature
Description	Use this function to display the current electronics temperature.

Min/Max values Submenu

Sensor n min value	
	NOTE: n = Stands for the number of sensor inputs (1 and 2)
Navigation	Diagnostics → Measured values → Min/max values → Sensor n min value Expert → Diagnostics → Measured values → Min/max values → Sensor n min value
Description	Use this function to display the minimum temperature measured in the past at sensor input 1 or 2 (peakhold indicator).

Sensor n max value	
	NOTE: n = Stands for the number of sensor inputs (1 and 2)
Navigation	Diagnostics → Measured values → Min/max values → Sensor n max value Expert → Diagnostics → Measured values → Min/max values → Sensor n max value
Description	Use this function to display the maximum temperature measured in the past at sensor input 1 or 2 (peakhold indicator).

Reset sensor min/max values	
Navigation	Diagnostics → Measured values → Min/max values → Reset sensor min/max values Expert → Diagnostics → Measured values → Min/max values → Reset sensor min/max values
Description	Reset the peakhold indicators for the minimum and maximum temperatures measured at the sensor inputs.
Options	<ul style="list-style-type: none"> ▶ No ▶ Yes
Factory setting	No

Device temperature min.	
Navigation	Diagnostics → Measured values → Min/max values → Device temperature min. Expert → Diagnostics → Measured values → Min/max values → Device temperature min.
Description	Use this function to display the minimum electronics temperature measured in the past (peakhold indicator).

Device temperature max.	
Navigation	Diagnostics → Measured values → Min/max values → Device temperature max. Expert → Diagnostics → Measured values → Min/max values → Device temperature max.
Description	Use this function to display the maximum electronics temperature measured in the past (peakhold indicator).

Reset device temp. min/max values	
Navigation	Diagnostics → Measured values → Min/max values → Reset device temp. min/max values Expert → Diagnostics → Measured values → Min/max values → Reset device temp. min/max values
Description	Reset the peakhold indicators for the minimum and maximum electronic temperatures measured.
Options	<ul style="list-style-type: none"> ▶ No ▶ Yes
Factory setting	No

Simulation Submenu

Simulation current output	
Navigation	Diagnostics → Simulation → Simulation current output Expert → Diagnostics → Simulation → Simulation current output
Description	Use this function to switch simulation of the current output on and off. The display alternates between the measured value and a diagnostics message of the "function check" category (C) while simulation is in progress.
Display	Measured value display ↔ C491 (simulation current output)
Options	<ul style="list-style-type: none"> ▶ Off ▶ On
Factory setting	Off
Additional information	The simulation value is defined in the Value current output parameter.

Value current output	
Navigation	Diagnostics → Simulation → Value current output Expert → Diagnostics → Simulation → Value current output
Additional information	The Simulation current output parameter must be set to On .
Description	Use this function to set a current value for the simulation. In this way, users can verify the correct adjustment of the current output and the correct function of downstream switching units.
User entry	3.59 to 23.0 mA
	3.59 mA

Expert Menu

— NOTE —

The parameter groups for the Expert setup contain all the parameters of the “Setup” and “Diagnostics” operating menus, as well as other parameters that are solely reserved for experts. Descriptions of the additional parameters can be found in this section. All the fundamental parameter settings for transmitter commissioning and diagnostic evaluation are described in the “Setup Menu” on page 42 and “Diagnostics Menu” on page 58.

System Submenu

Damping	
Navigation	Expert → System → Damping
Description	Use this function to set the time constant for current output damping.
User entry	0 to 120 s
Factory setting	0.00 s
Additional information	The current output reacts with an exponential delay to fluctuations in the measured value. The time constant of this delay is specified by this parameter. If a low time constant is entered, the current output follows the measured value quickly. On the other hand, if a high time constant is entered, the current output reaction is delayed.

Alarm delay	
Navigation	Expert → System → Alarm delay
Description	Use this function to set the delay time during which a diagnostics signal is suppressed before it is output.
User entry	0 to 5 s
Factory setting	2 s

Mains filter	
Navigation	Expert → System → Mains filter
Description	Use this function to select the mains filter for A/D conversion.
User entry	<ul style="list-style-type: none"> ▶ 50 Hz ▶ 60 Hz
Factory setting	50 Hz

Device temperature alarm	
Navigation	Expert → System → Device temperature alarm
For details, see “Device temperature alarm” on page 46.	

Display Submenu

For details, see “Display Submenu” on page 51.

Administration Submenu

For details, see “Administration Submenu” on page 58.

Sensor Submenu

Sensor 1/2 Submenu

— NOTE

n = Stands for the number of sensor inputs (1 and 2)

Sensor n lower limit	
Navigation	Expert → Sensor → Sensor n → Sensor n lower limit
Description	Displays the minimum physical full scale value.

Sensor n upper limit	
Navigation	Expert → Sensor → Sensor n → Sensor n upper limit
Description	Displays the maximum physical full scale value.

Sensor serial number	
Navigation	Expert → Sensor → Sensor n → Sensor serial number
Description	Use this function to enter the serial number of the connected sensor.
User entry	String with up to 12 characters consisting of numbers and/or text.
Factory setting	" " (no text)

Sensor Trimming Submenu

Sensor Error Adjustment (Sensor Trimming)

Sensor trimming is used to adapt the actual sensor signal to the linearization of the selected sensor type stored in the transmitter. Compared to sensor transmitter matching, sensor trimming only takes place at the start and end value and does not achieve the same level of accuracy.

— NOTE

Sensor trimming does not adapt the measuring range. It is used to adapt the sensor signal to the linearization stored in the transmitter.

Table 14. Procedure for Sensor Trimming

1. Start
↓
2. Set the Sensor trimming parameter to the Customer-specific setting.
↓
3. Using a water/oil bath, bring the sensor connected to the transmitter to a known and stable temperature. A temperature which is close to the set start of the measuring range is recommended.
↓
4. Enter the reference temperature for the value at the start of the measuring range for the Sensor trimming lower value parameter. Based on the difference between the specified reference temperature and the temperature actually measured at the input, the transmitter internally calculates a correction factor which is now used to linearize the input signal.
↓
5. Using a water/oil bath, bring the sensor connected to the transmitter to a known and stable temperature close to the set end of the measuring range.
↓
6. Enter the reference temperature for the value at the end of the measuring range for the Sensor trimming upper value parameter.
↓
7. End

Sensor trimming	
Navigation	Expert → Sensor → Sensor n → Sensor trimming → Sensor trimming
Description	Use this function to select the linearization method to be used for the connected sensor. NOTE: The original linearization can be restored by resetting this parameter to the Factory setting option.
Options	<ul style="list-style-type: none"> ▶ Factory setting ▶ Customer-specific
Factory setting	Factory setting

Sensor trimming lower value	
Navigation	Expert → Sensor → Sensor n → Sensor trimming → Sensor trimming lower value
Prerequisite	The Customer-specific option is enabled in the Sensor trimming parameter (see “Sensor trimming” on page 67).
Description	Lower point for linear characteristic calibration (this affects offset and slope).
User entry	Depends on the selected sensor type and the assignment of the current output (PV).
Factory setting	-200 °C

Sensor trimming upper value	
Navigation	Expert → Sensor → Sensor n → Sensor trimming → Sensor trimming upper value
Prerequisite	The Customer-specific option is enabled in the Sensor trimming parameter (see “Sensor trimming” on page 67).
Description	Upper point for linear characteristic calibration (this affects offset and slope).
User entry	Depends on the selected sensor type and the assignment of the current output (PV).
Factory setting	850 °C

Sensor trimming min span	
Navigation	Expert → Sensor → Sensor n → Sensor trimming → Sensor trimming min span
Prerequisite	The Customer-specific option is enabled in the Sensor trimming parameter (see “Sensor trimming” on page 67).
Description	Use this function to view the minimum possible span between the sensor trimming upper and lower value.

Linearization Submenu

Table 15. Procedure for Configuring a Linearization using Callendar/Van Dusen Coefficients from a Calibration Certificate

1. Start
↓
2. Assign current output (PV) = set sensor 1 (measured value).
↓
3. Select unit (°C).
↓
4. Select the sensor type (linearization type) “RTD platinum (Callendar/Van Dusen)”
↓
5. Select connection mode e.g. 3-wire.
↓
6. Set the lower and upper sensor limits.
↓
7. Enter the four coefficients A, B, C and R0.
↓
8. If special linearization is also used for a second sensor, repeat steps 2 to 6.
↓
9. End

Sensor n lower limit	
Navigation	Expert → Sensor → Sensor n → Linearization → Sensor n lower value
Prerequisite	The RTD platinum, RTD poly nickel or RTD copper polynomial option is enabled in the Sensor type parameter.
Description	Use this function to set the lower calculation limit for special sensor linearization.
User entry	Depends on the sensor type selected.
Factory setting	-200 °C

Sensor n upper limit	
Navigation	Expert → Sensor → Sensor n → Linearization → Sensor n upper value
Prerequisite	The RTD platinum, RTD poly nickel or RTD copper polynomial option is enabled in the Sensor type parameter.
Description	Use this function to set the upper calculation limit for special sensor linearization.
User entry	Depends on the sensor type selected.
Factory setting	850 °C

Call./v. Dusen coeff. R0	
Navigation	Expert → Sensor → Sensor n → Linearization → Call./v. Dusen coeff. R0
Prerequisite	The RTD platinum (Callendar/Van Dusen) option is enabled in the Sensor type parameter.
Description	Use this function to set the R0 Value only for linearization with the Callendar/Van Dusen polynomial.
User entry	40.000 to 1 050.000
Factory setting	100.000 Ohm

Call./v. Dusen coeff. A, B, C	
Navigation	Expert → Sensor → Sensor n → Linearization → Call./v. Dusen coeff. A, B, C
Prerequisite	The RTD platinum (Callendar/Van Dusen) option is enabled in the Sensor type parameter.
Description	Use this function to set the coefficients for sensor linearization based on the Callendar/Van Dusen method.
Factory setting	<ul style="list-style-type: none"> ▶ A: 3.910000e-003 ▶ B: -5.780000e-007 ▶ C: -4.180000e-012

Polynomial coeff. R0	
Navigation	Expert → Sensor → Sensor n → Linearization → Polynomial coeff. R0
Prerequisite	The RTD poly nickel or RTD copper polynomial option is enabled in the Sensor type parameter.
Description	Use this function to set the R0 Value only for linearization of nickel/copper sensors.
User entry	40.000 to 1 050.000 Ohm
Factory setting	100.00 Ohm

Polynomial coeff. A, B	
Navigation	Expert → Sensor → Sensor n → Linearization → Polynomial coeff. A, B
Prerequisite	The RTD poly nickel or RTD copper polynomial option is enabled in the Sensor type parameter.
Description	Use this function to set the coefficients for sensor linearization of copper/nickel resistance thermometers.
Factory setting	Polynomial coeff. A = 5.49630e-003 Polynomial coeff. B = 6.75560e-006

Diagnostic Settings Submenu

Calibration counter start	
Navigation	Expert → Sensor → Diagnostic settings → Calibration counter start
Description	Option to control the calibration counter. NOTE: <ul style="list-style-type: none"> ▶ The countdown duration (in days) is specified with the Calibration counter start value parameter. ▶ The status signal issued when the limit value is reached is defined with the Calibration alarm category parameter.
Options	<ul style="list-style-type: none"> ▶ Off: Stops the calibration counter ▶ On: Starts the calibration counter ▶ Reset + run: Resets to the set start value and starts the calibration counter
Factory setting	Off

Calibration alarm category	
Navigation	Expert → Sensor → Diagnostic settings → Calibration alarm category
Description	Use this function to select the category (status signal) as to how the device reacts when the set calibration countdown expires.
Options	<ul style="list-style-type: none"> ▶ Maintenance required (M) ▶ Failure (F)
Factory setting	Maintenance required (M)

Calibration counter start value	
Navigation	Expert → Sensor → Diagnostic settings → Calibration counter start value
Description	Use this function to set the start value for the calibration counter.
User entry	0 to 365 d (days)
Factory setting	365

Calibration countdown	
Navigation	Expert → Sensor → Diagnostic settings → Calibration countdown
Description	Use this function to view the time remaining until the next calibration. Calibration countdown only runs when the device is active. Example: If the calibration counter is set to 365 days on January 1, 2011 and no electricity is supplied to the device for 100 days, the alarm for the calibration appears on April 10, 2012.

Output Submenu

Measuring mode	
Navigation	Expert → Output → Measuring mode
Description	Enables the inversion of the output signal.
Additional information	<ul style="list-style-type: none"> ▶ Standard The output current increases with increasing temperatures ▶ inverted The output current decreases with increasing temperatures
Options	<ul style="list-style-type: none"> ▶ Standard ▶ inverted
Factory setting	Standard

Communication Submenu

HART Configuration Submenu

Device tag	
Navigation	Diagnostics → Device information → Device tag Expert → Communication → HART configuration → Device tag
For details, see "Device tag" on page 42.	

HART short tag	
Navigation	Expert → Communication → HART configuration → HART short tag
Description	Use this function to define a short tag for the measuring point.
User entry	Up to 8 alphanumeric characters (letters, numbers and special characters)
Factory setting	SHORTTAG

HART address	
Navigation	Expert → Communication → HART configuration → HART address
Description	Use this function to define the HART address of the device.
User entry	0 ... 63
Factory setting	0
Additional information	The measured value can only be transmitted via the current value if the address is set to "0". The current is fixed at 4.0 mA for all other addresses (Multidrop mode).

No. of preambles	
Navigation	Expert → Communication → HART configuration → No. of preambles
Description	Use this function to define the number of preambles in the HART telegram.
User entry	2 ... 20
Factory setting	5

Configuration changed	
Navigation	Expert → Communication → HART configuration → Configuration changed
Description	Indicates whether the configuration of the device has been changed by a master (primary or secondary).

Reset configuration changed flag	
Navigation	Expert → Communication → HART configuration → Reset configuration changed flag
Description	The Configuration changed information is reset by a master (primary or secondary).

HART Info Submenu

Device type	
Navigation	Expert → Communication → HART info → Device type
Description	Use this function to view the device type with which the device is registered with the HART Communication Foundation. The device type is specified by the manufacturer. It is needed to assign the appropriate device description file (DD) to the device.
Display	2-digit hexadecimal number
Factory setting	0xcc

Device revision	
Navigation	Expert → Communication → HART info → Device revision
Description	Use this function to view the device revision with which the device is registered with the HART® Communication Foundation. It is needed to assign the appropriate device description file (DD) to the device.
Factory setting	2

HART revision	
Navigation	Expert → Communication → HART info → HART revision
Description	Use this function to display the HART revision of the device.

HART descriptor	
Navigation	Expert → Communication → HART info → HART descriptor
Description	Use this function to define a description for the measuring point.
User entry	Up to 32 alphanumeric characters (letters, numbers and special characters).
Factory setting	The device name

HART message	
Navigation	Expert → Communication → HART info → HART message
Description	Use this function to define a HART message which is sent via the HART protocol when requested by the master.
User entry	Up to 32 alphanumeric characters (letters, numbers and special characters).
Factory setting	The device name

Hardware revision	
Navigation	Expert → Communication → HART info → Hardware revision
Description	Use this function to display the hardware revision of the device.

SWRev	
Navigation	Expert → Communication → HART info → SWRev
Description	Use this function to display the software revision of the device.

HART date code	
Navigation	Expert → Communication → HART info → HART data code
Description	Use this function to define date information for individual use.
User entry	Date in the format year-month-day (YYYY-MM-DD)
Factory setting	2010-01-01

HART Output Submenu

Assign current output (PV)	
Navigation	Expert → Communication → HART output → Assign current output (PV)
Description	Use this function to assign a measured variable to the primary HART value (PV).
Options	<ul style="list-style-type: none"> ▶ Sensor 1 (measured value) ▶ Sensor 2 (measured value) ▶ Device temperature ▶ Average of the two measured values: $0.5 \times (SV1+SV2)$ ▶ Difference between sensor 1 and sensor 2: $SV1-SV2$ ▶ Sensor 1 (backup sensor 2): If sensor 1 fails, the value of sensor 2 automatically becomes the primary HART® value (PV): sensor 1 (OR sensor 2) ▶ Sensor switching: If the value exceeds the configured threshold value T for sensor 1, the measured value of sensor 2 becomes the primary HART® value (PV). The system switches back to sensor 1 if the measured value of sensor 1 is at least 2 K below T: sensor 1 (sensor 2, if sensor 1 > T) ▶ Average: $0.5 \times (SV1+SV2)$ with backup (measured value of sensor 1 or sensor 2 in the event of a sensor error in the other sensor) <p>NOTE: The threshold value can be set with the Sensor switching limit value parameter. With temperature-dependent switching, it is possible to combine 2 sensors that offer advantages in different temperature ranges.</p>
Factory setting	Sensor 1

PV	
Navigation	Expert → Communication → HART output → PV
Description	Use this function to display the primary HART value.

Assign SV	
Navigation	Expert → Communication → HART output → Assign SV
Description	Use this function to assign a measured variable to the secondary HART value (SV).
Options	See Assign current output (PV) parameter on page 74.
Factory setting	Device temperature

SV	
Navigation	Expert → Communication → HART output → SV
Description	Use this function to display the secondary HART value.

Assign TV	
Navigation	Expert → Communication → HART output → Assign TV
Description	Use this function to assign a measured variable to the tertiary HART value (TV).
Options	See Assign current output (PV) parameter on page 74.
Factory setting	Sensor 1

TV	
Navigation	Expert → Communication → HART output → TV
Description	Use this function to display the tertiary HART value.

Assign QV	
Navigation	Expert → Communication → HART output → Assign QV
Description	Use this function to assign a measured variable to the quaternary (fourth) HART value (QV).
Options	See Assign current output (PV) parameter on page 74.
Factory setting	Sensor 1

QV	
Navigation	Expert → Communication → HART output → QV
Description	Use this function to display the quaternary HART value.

Burst Configuration Submenu

— **NOTE** —
Up to 3 burst modes can be configured.

Burst mode	
Navigation	Expert → Communication → Burst configuration → Burst mode
Description	Activation of the HART burst mode for burst message X. Message 1 has the highest priority, message 2 the second-highest priority, etc.
Options	<ul style="list-style-type: none"> ▶ Off The device only sends data to the bus at the request of a HART master ▶ On The device regularly sends data to the bus without being requested to do so.
Factory setting	Off

Burst command	
Navigation	Expert → Communication → Burst configuration → Burst command
Prerequisite	This parameter can only be selected if the Burst mode option is enabled.
Description	Use this function to select the command whose answer is sent to the HART master in the activated burst mode.
Options	<ul style="list-style-type: none"> ▶ Command 1 Read out the primary variable ▶ Command 2 Read out the current and the main measured value as a percentage ▶ Command 3 Read out the dynamic HART variables and the current ▶ Command 9 Read out the dynamic HART variables including the related status ▶ Command 33 Read out the dynamic HART variables including the related unit
Factory setting	Command 2
Additional information	Commands 1, 2, 3 and 9 are universal HART commands. Command 33 is a "Common-Practice" HART command. More details on this are provided in the HART specifications.

Burst variable n	
	NOTE: n = Number of burst variables (0 to 3)
Navigation	Expert → Communication → Burst configuration → Burst variable n
Prerequisite	This parameter can only be selected if the Burst mode option is enabled.
Description	Use this function to assign a measured variable to slots 0 to 3. NOTE: This assignment is only relevant for the burst mode. The measured variables are assigned to the 4 HART variables (PV, SV, TV, QV) in the "HART Output Submenu" on page 74.
Options	<ul style="list-style-type: none"> ▶ Sensor 1 (measured value) ▶ Sensor 2 (measured value) ▶ Device temperature ▶ Average of the two measured values: $0.5 \times (SV1+SV2)$ ▶ Difference between sensor 1 and sensor 2: $SV1-SV2$ ▶ Sensor 1 (backup sensor 2): If sensor 1 fails, the value of sensor 2 automatically becomes the primary HART® value (PV): sensor 1 (OR sensor 2) ▶ Sensor switching: If the value exceeds the configured threshold value T for sensor 1, the measured value of sensor 2 becomes the primary HART® value (PV). The system switches back to sensor 1 if the measured value of sensor 1 is at least 2 K below T: sensor 1 (sensor 2, if sensor 1 > T) <p>NOTE: The threshold value can be set with the Sensor switching limit value parameter. With temperature-dependent switching, it is possible to combine 2 sensors that offer advantages in different temperature ranges.</p> <p>Average: $0.5 \times (SV1+SV2)$ with backup (measured value of sensor 1 or sensor 2 in the event of a sensor error in the other sensor)</p>
Factory setting	<ul style="list-style-type: none"> ▶ Burst variable slot 0: sensor 1 ▶ Burst variable slot 1: device temperature ▶ Burst variable slot 2: sensor 1 ▶ Burst variable slot 3: sensor 1

Burst trigger mode	
Navigation	Expert → Communication → Burst configuration → Burst trigger mode
Prerequisite	This parameter can only be selected if the Burst mode option is enabled.
Description	Use this function to select the event that triggers burst message X. NOTE: <ul style="list-style-type: none"> ▶ Continuous: The message is triggered in a time-controlled manner, at least observing the time interval defined in the "Burst min period X" parameter. ▶ Window: The message is triggered if the specified measured value has changed by the value defined in the "Burst trigger level X" parameter. ▶ Rising: The message is triggered if the specified measured value exceeds the value in the "Burst trigger level X" parameter. ▶ Falling: The message is triggered if the specified measured value falls below the value in the "Burst trigger level X" parameter. ▶ On change: The message is triggered if a measured value of the message changes.
Options	<ul style="list-style-type: none"> ▶ Continuous ▶ Window ▶ Rising ▶ Falling ▶ On change
Factory setting	Continuous

Burst trigger level	
Navigation	Expert → Communication → Burst configuration → Burst trigger level
Prerequisite	This parameter can only be selected if the Burst mode option is enabled. Description
Description	Use this function to enter the value which, together with the trigger mode, determines the time of burst message 1. This value determines the time of the message.
User entry	-1.0e ⁺²⁰ to +1.0e ⁺²⁰
Factory setting	-1.0e ⁺²⁰

Burst min period	
Navigation	Expert → Communication → Burst configuration → Burst min period
Prerequisite	This parameter can only be selected if the Burst mode option is enabled.
Description	Use this function to enter the minimum time span between two burst commands of burst message X. The value is entered in the unit 1/32 milliseconds.
User entry	500 to [value entered for the maximum interval in the Burst max period parameter] in whole numbers,
Factory setting	1000

Burst max period	
Navigation	Expert → Communication → Burst configuration → Burst max period
Prerequisite	This parameter can only be selected if the Burst mode option is enabled.
Description	Use this function to enter the maximum time span between two burst commands of burst message X. The value is entered in the unit 1/32 milliseconds.
User entry	[Value entered for the minimum interval in the Burst min period parameter] to 3600000 in whole numbers
Factory setting	2000

Diagnostics Submenu

Diagnostic List Submenu

For details, see “Diagnostic List Submenu” on page 59.

Event Logbook Submenu

For details, see “Event Logbook Submenu” on page 60.

Device Information Submenu

Extended order code 1-3	
Navigation	Expert → Diagnostics → Device information → Extended order code 1-3
Description	Use this function to display the first, second and/or third part of the extended order code. On account of length restrictions, the extended order code is split into a maximum of 3 parameters. The extended order code indicates the version of all the features of the product structure for the device and thus uniquely identifies the device. It can also be found on the nameplate. NOTE: Uses of the extended order code <ul style="list-style-type: none"> ▶ To order an identical spare device. ▶ To check the ordered device features using the delivery note.

ENP version	
Navigation	Expert → Diagnostics → Device information → ENP version
Description	Displays the version of the electronic nameplate.
Display	6-digit number in the format xx.yy.zz

Device revision	
Navigation	Expert → Diagnostics → Device information → Device revision Expert → Communication → HART info → Device revision
Description	Use this function to view the device revision with which the device is registered with the HART Communication Foundation. It is needed to assign the appropriate device description file (DD) to the device.
Display	2-digit hexadecimal number

Manufacturer ID	
Navigation	Expert → Diagnostics → Device information → Manufacturer ID
Description	Use this function to view the manufacturer ID with which the device is registered with the HART Communication Foundation.
Display	2-digit hexadecimal number
Factory setting	17

Manufacturer	
Navigation	Expert → Diagnostics → Device information → Manufacturer
Description	Displays the manufacturer name.

Hardware revision	
Navigation	Expert → Diagnostics → Device information → Hardware revision Expert → Communication → HART info → Hardware revision
Description	Use this function to display the hardware revision of the device.

Measured Value Submenu

Sensor n raw value	
	NOTE: n = Stands for the number of sensor inputs (1 and 2)
Navigation	Expert → Diagnostics → Measured value → Sensor n raw value
Description	Use this function to display the non-linearized mV/Ohm value at the specific sensor input.

Min/Max Values Submenu

For details, see “Min/Max values Submenu” on page 62.

Simulation Submenu

For details, see “Simulation Submenu” on page 64.

5. Maintenance

The RTT80-T Transmitter basic unit has no moving parts and is a completely sealed unit. If there is a problem, refer to the following troubleshooting section for possible corrective actions.

! CAUTION

The basic transmitter is completely sealed unit and cannot be repaired. Any attempt to open the basic transmitter voids the warranty.

! DANGER

For nonintrinsically safe installations, to prevent a potential explosion in a Division 1 hazardous area, deenergize the transmitter before you remove the threaded housing cover. Failure to comply with this warning could result in an explosion resulting in severe injury or death.

Troubleshooting

Table 16. Recommended Troubleshooting Steps Before Replacing Module

Indication	Action
Erratic Measurement	Check Wiring Connections – Look for any loose connections or corroded terminals
	Check Sensor – See instrument diagnostics (a) or use a multimeter to measure sensor
	Check Grounding – Look for ground loops or noise on the bus with a digital scope
	Check Power Supply – Check for adequate power levels
	Check that the sensor type configured matches the sensor type being used
Inaccurate Measurement	Check Sensor - See instrument diagnostics (a) or use a multimeter to measure sensor
	Check Grounding - Look for ground loops or noise on the bus with a digital scope
	Check Sensor Calibration – User multimeter to approximate sensor input or use a temperature bath for more accuracy
	Check Transmitter Calibration – Use a decade box or millivolt input to simulate sensor output
	Check Instrument Configuration – Check configured ranges and check for any unintentional rescaling
Device will not Communicate	Check Instrument Configuration – Check for correct addressing, correct tagging, and so forth. (digital communications)
	Check Power Supply– Check for adequate power levels. Check signal strength at I/O card
	Check Grounding – Look for ground loops or noise on the bus with a digital scope
	Check that there is a minimum of 250 Ω loop resistance between the power supply and the HART Communicator

Table 16. Recommended Troubleshooting Steps Before Replacing Module (Continued)

Indication	Action
Transmitter is in Failsafe	Check Sensor – See instrument diagnostics (a) or use a multimeter to measure sensor
	Check Wiring Connections – Look for any loose connections or corroded terminals
	Check Configuration (Ranges, sensor type, and so forth.)
	Check Transmitter Calibration – Use a decade box or millivolt input to simulate sensor output

a. Using a HART Communicator or PC-Based Configurator.

Figure 22. Troubleshooting Diagram

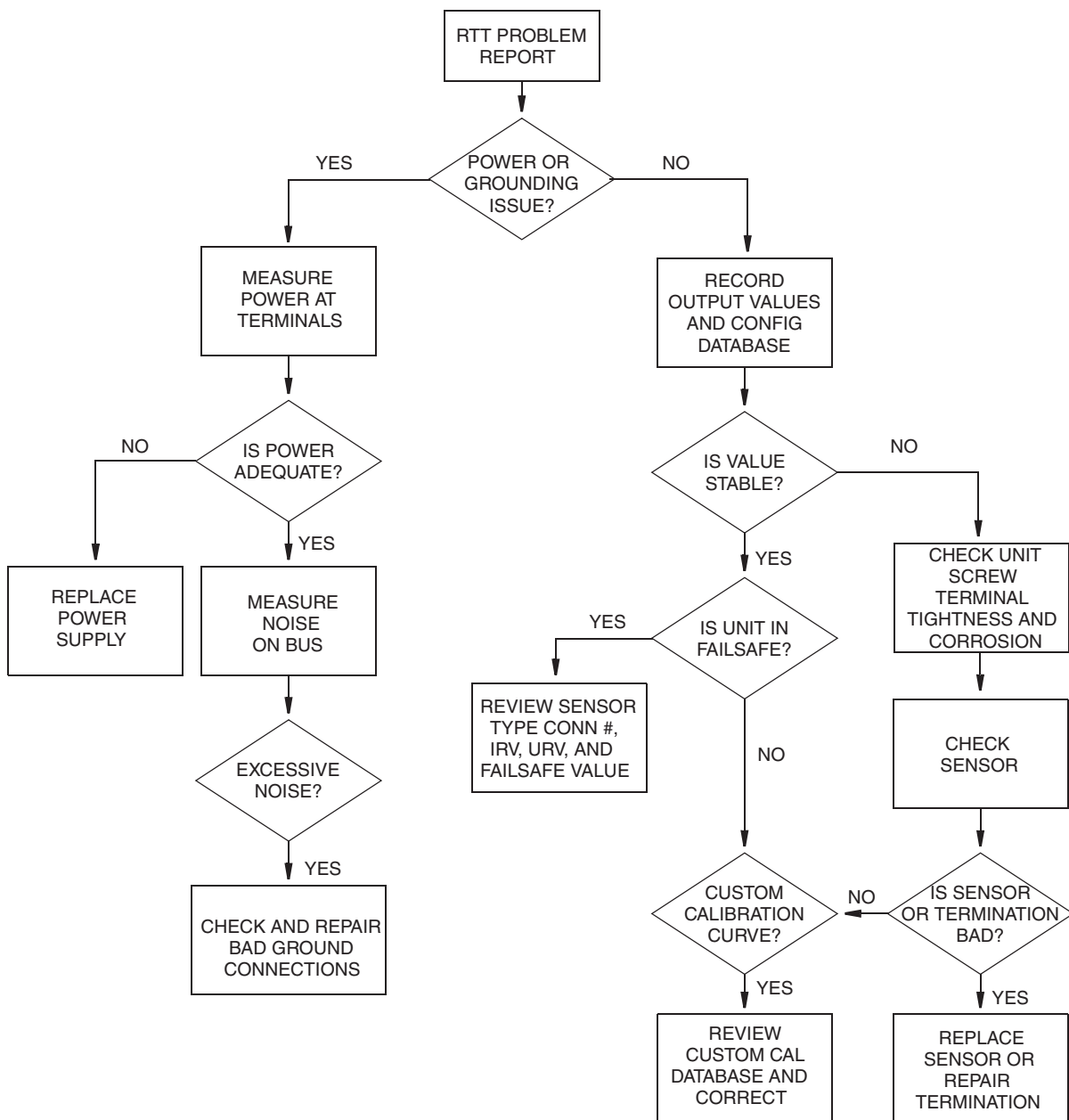

Replacing the Transmitter

DIN Rail Mounted Units

1. Turn off the transmitter power source.
2. If the optional display is present, unplug the display from the transmitter by gently pulling it away.
3. Disconnect all wires from the transmitter noting which wire went to each terminal.
4. Remove the transmitter by removing the screw and the bushing that secures it to the DIN Clip.
5. Install the new transmitter by reversing Steps 1 to 4 above and torque the screw to 8 ± 1 in-lb.

Universal Housing Mounted Units

1. Turn off the transmitter power source.
2. Remove the housing cover (if applicable).
3. If the optional display is present, unplug the display from the transmitter by gently pulling it away.
4. Disconnect all wires from the transmitter noting which wire went to each terminal.

Figure 23. Input Connections

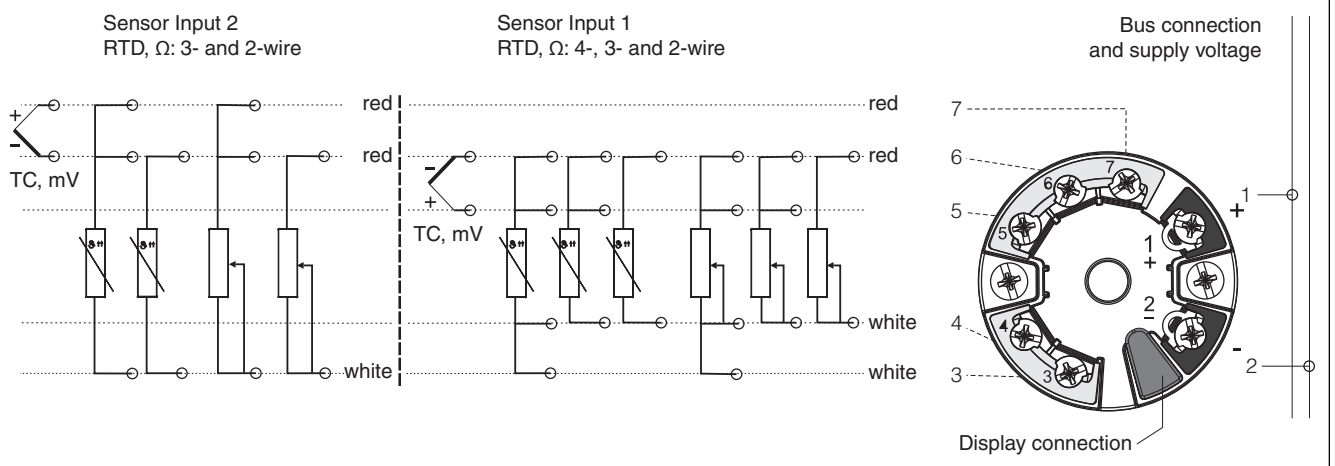

5. Remove the transmitter by removing the two screws that secure it to the housing.
6. Install the new transmitter by reversing Steps 1 to 5 above and torque the screws to 8 ± 1 in-lb.

NOTE

It is recommended that the screws be replaced when the transmitter is replaced.

! CAUTION

When replacing housing cover, tighten the cover so that the flange of the cover comes in contact with the flange on the housing.

Dual Compartment Housing Mounted Units

1. Turn off the transmitter power source.
2. Remove the housing cover.
3. If the optional display is present, unplug the display from the transmitter by gently pulling it away.
4. Disconnect all the color-coded wires from the transmitter, and note which wire went to each terminal:

Terminal 1	Red
Terminal 2	Brown
Terminal 3	Orange
Terminal 4	Yellow
Terminal 5	Green
Terminal 6	Blue
Terminal 7	Purple

5. Remove the transmitter by loosening the two screws that secure it to the mounting plate.
6. Install the new transmitter by reversing Steps 1 to 5 above and torquing the screws to 7 ±1 in-lb.

NOTE

It is recommended that the screws be replaced when the transmitter is replaced.

! CAUTION

When replacing housing covers, tighten each cover so that the flange of the cover comes in contact with the flange of the housing.

Diagnostics

Diagnostic error messages may be manifested either by the optional display or by a means of device interface, such as DD or DTM.

Diagnostic errors are communicated in four levels as listed below:

Table 17. Diagnostic Errors

Diagnostic Symbol	Category	Description
F	Device Failure	The measured value is no longer valid.
M	Maintenance Required	The measurement is valid but device maintenance should be scheduled soon.
C	Service Mode	The device is operating correctly but it has been taken out of service and the measurement may not be valid.

Table 17. Diagnostic Errors

Diagnostic Symbol	Category	Description
S	Out of Specification	The device is operating outside of prescribed specification limits. Measurement may be valid.

Some diagnostic events may be configured to one or more of the above categories.

Diagnostic severity can be categorized as described below:

Table 18. Diagnostic Severity

Severity	Behavior
Alarm	The measurement is interrupted. The device will take on the failure condition that has been prescribed (i.e. failsafe). Diagnostic messages will reference the Device Failure (F) category.
Warning	The device continues to communicate a measurement. Diagnostic message will reference the Maintenance Required (M), Service (C) or Out of Specification (S) category.

Some diagnostic events may be user-configured for severity.

Display

The optional display will annunciate a diagnostic event.

In the event of a warning, the display will alternate between the diagnostic code number preceded by the category (M, C or S) symbol and the configured measurement. For example, a corroded sensor that is configured for a Maintenance category will display “M042” on black background alternating with the measurement in a normal format (black characters on green background).

In the event of an alarm, the display will alternate between the diagnostic code number preceded by the “F” symbol and “----” to indicate no measurement. For example, a broken sensor with no redundancy will display “F041” on black alternating with “----” in black characters on green background.

See Table 19 for diagnostic codes and descriptions.

The optional display will show the current diagnostic with the highest priority. If more than one diagnostic is active, all current diagnostic messages can be read using a Device Interface.

Device Interface

Diagnostic messages can be read via a device interface, such as an SDC 625 (HART-compliant) host, hand-held configurator or Field Device Tool frame application such as a DTM. More detailed information is available with these interfaces.

See the “Diagnostics Menu” on page 58 section for details of configuring diagnostics. See MI 020-520 for RTT80 diagnostics DTM screens.

Table 19. Diagnostic Events

Diagnostic Number	Short Text	Corrective Measures	Status Signal from the Factory	Diagnostic Behavior from the Factory
			Can be Changed to	
Diagnostics for the Sensor				
001	Device malfunction	1. Reboot device. 2. Check electrical connection of sensor. 3. Check/replace sensor. 4. Replace electronics.	F	Alarm
006	Redundancy active	1. Check electrical wiring. 2. Replace sensor. 3. Check connection type.	M	Warning
041	Sensor broken	1. Check electrical wiring. 2. Replace sensor. 3. Check connection type.	F	Alarm
042	Sensor corroded	1. Check electrical wiring of sensor. 2. Replace sensor.	M F	Warning (a)
043	Short circuit	1. Check electrical wiring. 2. Replace sensor.	F	Alarm
044	Sensor drift	1. Check sensors. 2. Check process temperatures.	M F, S	Warning
045	Working area	1. Check ambient temperature. 2. Check external reference measuring point.	F	Alarm
062	Sensor connection	1. Check electrical connection of sensor. 2. Replace sensor. 3. Check sensor configuration. 4. Contact service.	F	Alarm
101	Sensor value too low	1. Check process temperatures. 2. Inspect sensor. 3. Check sensor type.	S F	Warning
102	Sensor value too high	1. Check process temperatures. 2. Inspect sensor. 3. Check sensor type.	S F	Warning
104	Backup active	1. Check electrical wiring of sensor 1. 2. Replace sensor 1. 3. Check connection type.	M	Warning
105	Calibration interval	1. Execute calibration and reset calibration interval. 2. Switch off calibration counter.	M F	Warning
106	Backup not available	1. Check electrical wiring of sensor 2. 2. Replace sensor 2. 3. Check connection type.	M	Warning
Diagnostics for the Electronics				
201	Device malfunction	Replace electronics.	F	Alarm
221	Reference measurement	Replace electronics.	F	Alarm
241	Software	1. Restart device. 2. Perform device reset. 3. Replace device.	F	Alarm
242	Software incompatible	Contact service.	F	Alarm
261	Electronics module	Replace electronics.	F	Alarm
262	Module connection short circuit	1. Ensure that display module is correctly seated on the head transmitter. 2. Test the display module using other suitable head transmitters. 3. Display module defective? Replace module.	M	Warning

Table 19. Diagnostic Events (Continued)

Diagnostic Number	Short Text	Corrective Measures	Status Signal from the Factory	Diagnostic Behavior from the Factory
			Can be Changed to	
282	Electronic memory	Replace device.	F	Alarm
283	Memory content	Replace electronics.	F	Alarm
301	Supply voltage	1. Increase supply voltage. 2. Check connection wires for corrosion.	F	Alarm
Diagnostics for the Configuration				
401	Factory reset	Please wait until the reset procedure is complete.	C	Warning
402	Initialization	Please wait until start-up procedure is complete	C	Warning
410	Data transfer	Check HART communication.	F	Alarm
411	Upload/download	Please wait until the upload/download is complete.	F, M, or C (b)	-
431	Factory calibration (c)	Replace electronics.	F	Alarm
435	Linearization	1. Check configuration of sensor parameters. 2. Check configuration of special sensor linearization. 3. Contact service. 4. Replace electronics.	F	Alarm
437	Configuration	1. Check configuration of sensor parameters. 2. Check configuration of special sensor linearization. 3. Check configuration of transmitter settings. 4. Contact service.	F	Alarm
438	Dataset	Repeat the safe parameterization.	F	Alarm
451	Data processing	Please wait until data processing is complete.	C	Warning
483	Simulation input	Deactivate simulation.	C	Warning
485	Measured value simulation			
491	Simulation current output			
501	CDI connection	Unplug CDI connector.	C	Warning
525	HART communication	1. Check communication path (Hardware). 2. Check HART-master. 3. Check if power is sufficient. 4. Check HART communication settings. 5. Contact service organization.	F	Alarm
Diagnostics for the Process				
803	Current loop	1. Check wiring. 2. Replace electronics.	F	Alarm
842	Process limit value	Check scaling of analog output.	M F, S	Warning
925	Device temperature	Observe ambient temperature in accordance with specification.	S F	Warning

a. Diagnostic behavior can be changed in "Alarm" or "Warning".

b. Status signal depends on used communication system and cannot be changed.

c. In the case of this diagnostics event, the device always issues a "low" alarm status (output current ≤ 3.6 mA).

ISSUE DATES

NOV 2014

Vertical lines to the right of text or illustrations indicate areas changed at last issue date.



Invensys Systems, Inc.
10900 Equity Drive
Houston, TX 77041
United States of America
<http://www.invensys.com>

Global Customer Support
Inside U.S.: 1-866-746-6477
Outside U.S.: 1-508-549-2424
Website: <http://support.ips.invensys.com>

Copyright 2014 Invensys Systems, Inc.
All rights reserved.

Invensys, Foxboro, and I/A Series are trademarks of
Invensys Limited, its subsidiaries, and affiliates. All other
trademarks are the property of their respective owners.

Invensys is now part of Schneider Electric.