

**Instruction**

MI 020-582  
November 2014

**I/A Series<sup>®</sup> Temperature Transmitter  
Model RTT80-T with HART<sup>®</sup> Version 6 Protocol**



**Foxboro<sup>®</sup>**

**by Schneider Electric**



# Contents

Figures .....	5
Tables .....	7
<b>1. Introduction .....</b>	<b>9</b>
General Description .....	9
Reference Documents .....	9
Transmitter Identification.....	9
Standard Specifications.....	11
Electrical Certification Rating .....	14
Electrical Safety Specifications .....	14
ATEX Compliance Documents .....	15
PTB 12ATEX2006 .....	15
FM 13ATEX0068X.....	15
IECEX Compliance Documents .....	15
IECEX PTB 12.0045 .....	15
IECEX FMG 14.0005X.....	15
Warnings.....	15
<b>2. Installation .....</b>	<b>17</b>
Mounting.....	18
Requirements .....	18
Basic Module Mounting Options .....	19
Universal Housing Mounting Options .....	20
Dual Compartment Housing Mounting Options.....	21
Thermowell Mounting.....	22
Cover Locks .....	23
Universal Housing Cover Locks.....	23
Dual Compartment Housing Cover Locks .....	24
Wiring .....	24
Input Connections .....	25
Loop Wiring .....	26
Multidrop Communication.....	28
<b>3. Configuration and Operation .....</b>	<b>31</b>
Configuration .....	31

- Hardware Settings .....31
- User Roles .....31
  - Display/Operation – User role: Operator.....31
  - Setup – User role: Maintenance Technician .....32
  - Diagnostics – User role: Maintenance Technician .....34
  - Expert – User role: Expert.....36
- Operation .....41
  - Local Display.....42
  - Online Menu .....43
- 4. Maintenance..... 45**
  - Troubleshooting .....45
  - Replacing the Transmitter .....47
    - DIN Rail Mounted Units .....47
    - Universal Housing Mounted Units.....47
    - Dual Compartment Housing Mounted Units .....48
  - Diagnostics.....48
    - Display .....49
    - Device Interface.....49

# Figures

1	Typical Identification Label for Housing and Sensor Mounting Code BB .....	9
2	Typical Identification Labels for Universal Housing .....	10
3	Typical Identification Labels for Dual Compartment Housing .....	10
4	Basic Module Mounting Options (Housing and Sensor Mounting Code BB) .....	19
5	Universal Housing Mounting Options (Housing and Sensor Mounting Codes SS, TT, LL, MM, WW, and YY) .....	20
6	Dual Compartment Housing Mounting Options: Remote Sensor (Housing and Sensor Mounting Codes GG, HH, QQ, and RR) .....	21
7	Dual Compartment Housing Mounting Options: Integral Sensor (Housing and Sensor Mounting Codes CC, DD, EE, FF, JJ, KK, NN, and PP) .....	22
8	Thermowell Mounting (Dual Compartment Housing Shown) .....	22
9	Universal Housing Cover Lock.....	23
10	Dual Compartment Housing Cover Locks .....	24
11	Input Connections on the Basic Module and Universal Housing.....	25
12	Dual Compartment Housing Wiring from the Terminal Block to the Module.....	25
13	Supply Voltage and Loop Load.....	26
14	Transmitter Loop Wiring .....	28
15	Wiring Several Transmitters to a Common Power Supply .....	28
16	Typical Multidrop Network.....	29
17	Display DIP Switches.....	31
18	Display Information.....	42
19	Troubleshooting Diagram.....	46
20	Input Connections .....	47



# Tables

1	Reference Documents .....	9
2	Input Types, Ranges, and Limits .....	11
3	Housing Specifications .....	12
4	Electrical Safety Specifications .....	14
5	Display Information .....	42
6	Recommended Troubleshooting Steps Before Replacing Module .....	45
7	Diagnostic Errors .....	48
8	Diagnostic Severity .....	49
9	Diagnostic Codes .....	49





# 1. Introduction

## General Description

The RTT80 Temperature Transmitter is a microprocessor-based temperature transmitter that receives input signals from thermocouples, RTDs, resistance (ohms), or millivolt sources. It is offered in a basic module package or with universal or dual compartment housing options, and is available with HART® Version 6 communications protocol.

## Reference Documents

For additional and related information, refer to the documents listed in Table 1.

*Table 1. Reference Documents*

Document	Description
PSS 2A-1F8 A	Product Specification Sheet: Model RTT80 I/A Series® Temperature Transmitter
MI 020-580	Master Instruction: RTT80 I/A Series® Temperature Transmitter FM/CSA Safety Information
MI 020-581	Master Instruction: RTT80 I/A Series® Temperature Transmitter ATEX/IECEx Safety Information
DP 020-580	Dimensional Print: Model RTT80 I/A Series® Temperature Transmitters
PL 008-680	Parts List: Model RTT80 I/A Series® Intelligent Temperature Transmitters

## Transmitter Identification

See Figures 1, 2, and 3 for typical agency and data labels. For transmitters enclosed in a housing, the basic unit agency label is located on the basic unit and the applicable agency and data labels are externally mounted on the transmitter housing.

**NOTE**

Figures 1, 2, and 3 show typical data plates. For a recapitulation of the specific information that applies to each agency certification, see “Electrical Certification Rating” on page 14.

*Figure 1. Typical Identification Label for Housing and Sensor Mounting Code BB*

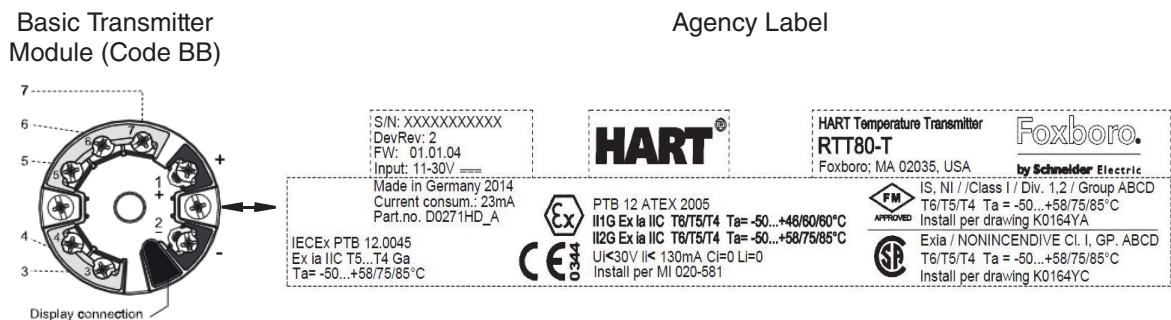

Figure 2. Typical Identification Labels for Universal Housing

**Universal Housing**  
(Codes LL, MM, SS, TT, WW, and YY)

**IECEX Agency Label**

SEE CERTIFICATES FOR ELECTRICAL DATA

ED  Ex d IIC T6 GbT4; -40°C to 70°C  
Ex Ib IIIC T85°C DbT4; -40°C to 70°C  
IECEX FMG 14.0005X; IP 66/67

EA  Ex Ia IIC T6, T4 Ga, T6; Ta; -50°C to 46°C  
T5; Ta; -50°C to 60°C, T4; Ta; -50°C to 60°C  
IECEX PTB 12.0045; IP 66/67

WARNING – DO NOT OPEN WHEN ENERGIZED

CE

K0168LL

**Flameproof and Intrinsic Safety Agency Label**

SEE CERTIFICATES FOR ELECTRICAL DATA

AD  II 2 GD Ex d IIC T6 GbT4; -40°C to 70°C  
Ex Ib IIIC T85°C DbT4; -40°C to 70°C  
FM 13ATEX0068A; IP 66/67

AA  II 2G Ex Ia IIC T6, T4 Ga, T6; Ta; -40°C to 55°C  
T5; Ta; -40°C to 70°C, T4; Ta; -40°C to 85°C  
PTB 12ATEX2005; IP 66/67

WARNING – DO NOT OPEN WHEN ENERGIZED

CE 0344

K0168SY

**Explosion Proof and Intrinsic Safety Agency Label (FM)**

FM APPROVED

FD  XP CL I, DIV 1, GP B, C, D; DIP CL II, III, DIV 1 GP E, F, G; T5 Ta = -40°C to +80°C; T6 -40°C to +70°C  
CL I, ZN 1, AEx d IIC; T5 Ta = -40°C to +80°C; T6 -40°C to +70°C

FA  IS CL I, DIV 1, GP A, B, C, D; CL I, ZN 0, AEx Ia IIC; T4; Ta = -40°C to +85°C;  
T5; Ta = -40°C to +70°C; T6; Ta = -40°C to +55°C; Install Per Drawing K0164YA

FN  NI CL I, DIV 2, GP A, B, C, D; T4 Ta = -40°C to +85°C; T5, Ta = -40°C to +70°C;  
T6, Ta = -40°C to +55°C; Install Per Drawing K0164YA

Type 4X / IP66/67

WARNING: EXPLOSION HAZARD: Keep Cover Tight while circuits are live unless area is known to be Non-Hazardous.  
Substitution of components may impair Intrinsic Safety or Division 2 Approval.  
SEAL NOT REQUIRED

CE

D0197LUK

**Data Label**

invensys  
**FOXBORO**

**I/A Series® TEMPERATURE TRANSMITTER**

MODEL REF. NO. RANGE CUST. DATA

ST ORIGIN

SER. NO. SUPPLY MWP

INVENSYS SYSTEMS, INC.  
33 Commercial St.  
FOXBORO, MA, U.S.A.

Figure 3. Typical Identification Labels for Dual Compartment Housing

**Dual Compartment Housing**  
(Codes CC, DD, EE, FF, GG, HH JJ, KK, NN, PP, QQ, RR)

**IECEX Label**

WARNING - DO NOT OPEN WHEN ENERGIZED

CE

**I/A Series® TEMPERATURE TRANSMITTER**

MODEL REF. NO. RANGE CUST. DATA

STYLE SERIAL NO. CAUTION: CABLE ENTRIES

ORIGIN SUPPLY

PERMANENTLY MARK ONE TYPE OF PROTECTION, ONCE CHOSEN, IT CAN NOT CHANGE. NOT FOLLOWING THESE INSTRUCTIONS WILL JEOPARDISE EXPLOSION SAFETY. SEE CERTIFICATES FOR ELECTRICAL DATA.

ED  Ex d IIC T6 GbT4; -40°C to 70°C  
Ex Ib IIIC T85°C DbT4; -40°C to 70°C  
IECEX FMG 14.0005X; IP 66/67

EA  Ex Ia IIC T6, T4 Ga, T6; Ta; -50°C to 46°C  
T5; Ta; -50°C to 60°C, T4; Ta; -50°C to 60°C  
IECEX PTB 12.0045; IP 66/67

K0168LP

**ATEX Label**

WARNING - DO NOT OPEN WHEN ENERGIZED

CE 0344

**I/A Series® TEMPERATURE TRANSMITTER**

MODEL REF. NO. RANGE CUST. DATA

STYLE SERIAL NO. CAUTION: CABLE ENTRIES

ORIGIN SUPPLY

PERMANENTLY MARK ONE TYPE OF PROTECTION, ONCE CHOSEN, IT CAN NOT CHANGE. NOT FOLLOWING THESE INSTRUCTIONS WILL JEOPARDISE EXPLOSION SAFETY. SEE CERTIFICATES FOR ELECTRICAL DATA.

AD  II 2 GD Ex d IIC T6 GbT4; -40°C to 70°C  
Ex Ib IIIC T85°C DbT4; -40°C to 70°C  
FM 13ATEX0068A; IP 66/67

AA  II 2G Ex Ia IIC T6, T4 Ga, T6; Ta; -40°C to 55°C  
T5; Ta; -40°C to 70°C, T4; Ta; -40°C to 85°C  
PTB 12ATEX2005; IP 66/67

K0168SZ

**FM Label**

SEAL NOT REQUIRED

CE

**I/A Series® TEMPERATURE TRANSMITTER**

MODEL REF. NO. RANGE CUST. DATA

STYLE SERIAL NO. CAUTION: CABLE ENTRIES

ORIGIN SUPPLY

PERMANENTLY MARK ONE TYPE OF PROTECTION, ONCE CHOSEN, IT CAN NOT CHANGE. NOT FOLLOWING THESE INSTRUCTIONS WILL JEOPARDISE EXPLOSION SAFETY. SEE CERTIFICATES FOR ELECTRICAL DATA.

FD  XP CL I, DIV 1, GP B, C, D; DIP CL II, III, DIV 1 GP E, F, G;  
CL I, ZN 1, AEx d IIC; T5 Ta = -40°C to +80°C; T6 -40°C to +70°C

FA  IS CL I, DIV 1, GP A, B, C, D; CL I, ZN 0, AEx Ia IIC; T4; Ta = -40°C to +85°C;  
T5; Ta = -40°C to +70°C; T6; Ta = -40°C to +55°C; Install Per Drawing K0164YA

FN  NI CL I, DIV 2, GP A, B, C, D; T4 Ta = -40°C to +85°C;  
T5, Ta = -40°C to +70°C, T6, Ta = -40°C to +55°C;  
Install Per Drawing K0164YA

Type 4X / IP66/67

APPROVED

D0197KA-A

**Data Label**

invensys  
**FOXBORO**

**I/A Series® TEMPERATURE TRANSMITTER**

MODEL REF. NO. RANGE CUST. DATA

STYLE SERIAL NO. CAUTION: CABLE ENTRIES

ORIGIN SUPPLY

INVENSYS SYSTEMS, INC.  
33 Commercial St.  
FOXBORO, MA, U.S.A.

# Standard Specifications

## Ambient Temperature Limits:

-40 and +85°C (-40 and +185°F)

### — NOTE —

To ensure proper operation, the ambient temperature limits at the housing should not be exceeded. This is particularly relevant when sensors/thermowells are directly connected to the housing and very high process temperatures are being measured. The transfer of heat from the process to the housing can be minimized by use of thermowell extensions, or in extreme cases, by using a remote housing installation.

## Supply Voltage Limits:

11 and 42 V dc

$V_{\max} = 30$  V dc when certified as intrinsically safe.

## Vibration Limits:

- ◆ Basic Transmitter Module, Housing and Sensor Mounting Code BB: 20 to 100 Hz for 4g per GL-guidelines, Chapter 2, 2003 Edition.
- ◆ RTT80 Housing and Sensor Mounting Codes CC, EE, GG, JJ, LL, NN, QQ, SS, and WW: 19 mm (0.75 in) Double Amplitude from 5 to 9 Hz, 0 to 30 m/s<sup>2</sup> (0 to 3 “g”) from 9 to 500 Hz
- ◆ RTT80 Housing and Sensor Mounting Codes DD, FF, HH, KK, MM, PP, RR, TT, and YY: 10 m/s<sup>2</sup> (1 g) maximum.

## Type of Input:

It is possible to connect two sensor inputs which are independent of each other. These are not galvanically isolated from each other.

*Table 2. Input Types, Ranges, and Limits*

Type of Input	Designation	Measuring Range Limits	Recommended Temperature Range	Min Span
<b>Resistance Thermometer (RTD)</b>				
Per IEC 60751:2008	Pt100	-200 and +850°C	–	10 K
	Pt200	-200 and +850°C	–	10 K
	Pt500	-200 and +500°C	–	10 K
	Pt1000	-200 and +250°C	–	10 K
Per JIS C1604:1984	Pt100	-200 and +510°C	–	10 K
Per DIN 43760 IPTS-68	Ni100	-60 and +250°C	–	10 K
	Ni120	-60 and +250°C	–	10 K
Per GOST 6651-94	Pt100	-200 and +850°C	–	10 K
	Pt50	-185 and +1100°C	–	10 K
	Cu50	-175 to 200°C	–	10 K
Per OIML R84: 2003 and GOST 6651-94	Cu50	-50 and +200°C	–	10 K
	Ni100	-60 and +180°C	–	10 K
	Ni120	-60 and +180°C	–	10 K
Per OIML R84: 2003	Cu50	-180 and +200°C	–	10 K
–	Pt100 (Callendar-van Dusen)	Note (a)	–	–

*Table 2. Input Types, Ranges, and Limits (Continued)*

Type of Input	Designation	Measuring Range Limits	Recommended Temperature Range	Min Span
–	Nickel Polynomial	Note (a)	–	–
–	Copper Polynomial	Note (a)	–	–
<b>Resistance Transmitter</b>				
–	Resistance Ohms	10 and 400 Ohms 10 and 2000 Ohms	–	–
<b>Thermocouples (TC) (b)</b>				
Per IEC 584 Part 1	Type B (PtRh30-PtRh6)	+40 and +1820°C	+100 to +1500°C	500K
	Type E (NiCr-CuNi)	-270 and +1000°C	0 to +750°C	50 K
	Type J (Fe-CuNi)	-210 and +1200°C	+20 to +700°C	50 K
	Type K (NiCr-Ni)	-270 and +1372°C	0 to +1100°C	50 K
	Type N (NiCrSi-NiSi)	-270 and +1300°C	0 to +1100°C	50 K
	Type R (PtRh13-Pt)	-50 and +1768°C	0 to +1400°C	500 K
	Type S (PtRh10-Pt)	-50 and +1768°C	0 to +1400°C	500 K
	Type T (Cu-CuNi)	-260 and +400°C	-185 to +350°C	50 K
Per ASTM E988/E230	Type C (W3Re-W25Re)	0 and +2315°C	0 to +2000°C	500K
	Type D (W5Re-W26Re)	0 and +2315°C	0 to +2000°C	500 K
Per DIN 43710	Type L (Fe-CuNi)	-200 and +900°C	0 to +700°C	50 K
	Type U (Cu-CuNi)	-200 and +600°C	-185 to +400°C	50 K
<b>Voltage Transmitter</b>				
–	Millivolt (mV)	-20 and +100 mV	-20 to +100 mV	–

- a. The measuring range limits are specified by entering the limit values that depend on the coefficients A to C and R0.
- b. Thermocouple accuracy specifications apply to the recommended range.

*Table 3. Housing Specifications*

Housing Code	Material and Finish	IEC/NEMA Rating	Explosion-proof and Flameproof	Mounting Configuration	Field Wiring Entrances on Housing
<b>Basic Module</b>					
BB	Encapsulated plastic	IP20 (a)	No	Basic Transmitter Module (b) (DIN Form B package)	None
<b>Universal Housing</b>					
LL	Low copper aluminum alloy; epoxy coated	IP66/67 NEMA 4X	Yes	Universal housing with integral sensor and thermowell	1/2 NPT
MM	Stainless steel	IP66/67 NEMA 4X	Yes	Universal housing with integral sensor and thermowell	1/2 NPT
SS	Low copper aluminum alloy; epoxy coated	IP66/67 NEMA 4X	Yes	Universal housing for surface or pipe mounting, remote sensor (c)	1/2 NPT
TT	Stainless steel	IP66/67 NEMA 4X	Yes	Universal housing for surface or pipe mounting, remote sensor <sup>(c)</sup>	1/2 NPT
WW	Low copper aluminum alloy; epoxy coated	IP66/67 NEMA 4X	Yes	Universal housing with integral bare sensor	1/2 NPT
YY	Stainless steel	IP66/67 NEMA 4X	Yes	Universal housing with integral bare sensor	1/2 NPT

Table 3. Housing Specifications (Continued)

Housing Code	Material and Finish	IEC/NEMA Rating	Explosion-proof and Flameproof	Mounting Configuration	Field Wiring Entrances on Housing
<b>Dual Compartment Housing</b>					
CC	Low copper aluminum alloy; epoxy coated	IP66/67 NEMA 4X	Yes	Dual-compartment housing with integral bare sensor	M20
DD	Stainless steel	IP66/67 NEMA 4X	Yes	Dual-compartment housing with integral bare sensor	M20
EE	Low copper aluminum alloy; epoxy coated	IP66/67 NEMA 4X	Yes	Dual-compartment housing with integral sensor and thermowell	M20
FF	Stainless steel	IP66/67 NEMA 4X	Yes	Dual-compartment housing with integral sensor and thermowell	M20
GG	Low copper aluminum alloy; epoxy coated	IP66/67 NEMA 4X	Yes	Dual-compartment housing for surface or pipe mounting, remote sensor <sup>(c)</sup>	M20
HH	Stainless steel	IP66/67 NEMA 4X	Yes	Dual-compartment housing for surface or pipe mounting, remote sensor <sup>(c)</sup>	M20
JJ	Low copper aluminum alloy; epoxy coated	IP66/67 NEMA 4X	Yes	Dual-compartment housing with integral bare sensor	1/2 NPT
KK	Stainless steel	IP66/67 NEMA 4X	Yes	Dual-compartment housing with integral bare sensor	1/2 NPT
NN	Low copper aluminum alloy; epoxy coated	IP66/67 NEMA 4X	Yes	Dual-compartment housing with integral sensor and thermowell	1/2 NPT
PP	Stainless steel	IP66/67 NEMA 4X	Yes	Dual-compartment housing with integral sensor and thermowell	1/2 NPT
QQ	Low copper aluminum alloy; epoxy coated	IP66/67 NEMA 4X	Yes	Dual-compartment housing for surface or pipe mounting, remote sensor <sup>(c)</sup>	1/2 NPT
RR	Stainless steel	IP66/67 NEMA 4X	Yes	Dual-compartment housing for surface or pipe mounting, remote sensor <sup>(c)</sup>	1/2 NPT

- a. The basic module, although encapsulated, has exposed terminals not protected from the environment.
- b. The basic module is typically used for replacement and spares purposes; it can also be mounted to a surface or to a DIN rail using a clip (Option -D1).
- c. Surface or pipe mounted using mounting set options -M1 or -M2.

**! WARNING**

For all RTT80-T Transmitters with an aluminum housing:  
 When used in a potentially explosive atmosphere requiring apparatus of equipment category 1 G, the transmitter must be installed so that, even in the event of rare instances, an ignition source due to impact or friction between the enclosure and iron/steel is excluded. This shall be considered during installation, particularly if the equipment is installed in a zone 0 location.

**Communication Rate:** 1200 baud

**Communication Distance:**

**Analog Mode:** 3050 m (10,000 ft)

**Multidrop Mode:** 1525 m (5000 ft)

## Electrical Certification Rating

The electrical certification is printed on the agency label which is located on the basic module and on the transmitter housing (if applicable). The Electrical Safety Design Code is also included as part of the model code on the data label which is located on the basic module or on the transmitter housing (if applicable). See Figure 2 and Figure 3 for examples of typical agency and data labels. For a complete explanation of the model code, see PL 008-680.

## Electrical Safety Specifications

**NOTE**

These transmitters have been designed to meet the electrical safety description listed in Table 4. For detailed information or status of testing laboratory approvals/certifications, contact Invensys.

*Table 4. Electrical Safety Specifications*

Testing Laboratory, Type of Protection, and Area Classification	Model Code Option
Non-hazardous area	ZZ
CSA IS, I/1+2/ABCD (a)	CA
CSA NI, 1/2/ABCD <sup>(a)</sup>	CN
CSA Explosionproof, Class I, Division 1, BCD; Dust-ignitionproof, Class II, Division 1, EFG, Class III, Division 1. Also zone certified, CI I, Zone 1, EX d IIC <sup>(a)</sup> (b)	CD
ATEX II 1G Ex ia IIC T4/T5/T6	AA
ATEX II 2 G Ex d T6 Gb Ta = -40°C to 70°C II 2 D Ex tb T85C Db <sup>(b)</sup>	AD
IECEX Ex ia IIC T4/T5/T6	EA
IECEX Ex d T6 Gb Ta = -40°C to 70°C Ex tb T85C Db <sup>(b)</sup>	ED
FM IS, I/1+2/ABCD	FA
FM NI, I/2/ABCD	FN
FM Explosionproof, Class I, Division 1, Groups B, C, and D; Dust-ignitionproof, Class II, Division 1, Groups E, F, and G, Class III Division 1	FD

a. Not available with dual compartment housings.

b. Not available with the basic module (Housing and Sensor Mounting Code BB).

## ATEX Compliance Documents

Directive 94/9/EC – Equipment or Protective Systems Intended for Use in Potentially Explosive Atmospheres.

Also, compliance with the essential health and safety requirements has been assured by compliance with the following documents as stated in the compliance certificate:

### *PTB 12ATEX2006*

II 2G Ex ia IIC T6..T4 Ga, T6; Ta (-40°C to 55°C); T5; Ta (-40°C to 70°C), T4;  
Ta (-40°C to 85°C)  
EN 60079-0:2009; EN 60079-11:2007

### *FM 13ATEX0068X*

II 2 GD Ex d IIC T6 Gb Ta (-40°C to 70°C)  
Ex tb IIIC T85°C Db Ta (-40°C to 70°C)  
EN 60079-0:2009; EN 60079-1:2007; EN 60079-31:2009

## IECEX Compliance Documents

### *IECEX PTB 12.0045*

Ex ia IIC T6..T4 Ga, T6; Ta(-50°C to 46°C)  
T5; Ta(-50°C to 60°C), T4; Ta(-50°C to 60°C)  
IEC 60079-0:2007-10 (edition 5); IEC 60079-11:2011 (edition 6); IEC 60079-26:2006  
(edition 2)

### *IECEX FMG 14.0005X*

Ex d IIC T6 Gb Ta = -40°C to 70°C  
Ex tb IIIC T85°C Db Ta = -40°C to 70°C  
IEC 60079-0:2007-10 (edition 5); IEC 60079-1:2007(edition 6); IEC 60079-31:2013  
(edition 2)

## Warnings

---

 **WARNING**

---

Do not open while circuits are energized.

---



---

 **WARNING**

---

Do not open when energized or when an explosive atmosphere may be present.

---



---

 **WARNING**

---

Substitution of components may impair intrinsic safety or Division 2 approvals.

---

---

**! WARNING**

---

The certificate numbers have an 'X' suffix which indicates that special conditions of installation and use apply. Those installing or inspecting this equipment must have access to the contents of the certificate or these instructions. The conditions listed in the certificate are reproduced below.

1. Some models have the main electronics enclosure manufactured from aluminum alloy. In rare cases, ignition sources due to impact and friction sparks could occur. This shall be considered during installation, particularly if the equipment is installed in a zone 0 location.
  2. When installed in flammable dust zones, under certain extreme circumstances an incendive electrostatic charge may build up on the painted surfaces, which are non-conducting. Therefore, the user/installer shall implement precautions to prevent the build up of electrostatic charge, for example, locate the equipment where a charge-generating mechanism (such as wind-blown dust) is unlikely to be present and clean with a damp cloth.
  3. When installed in a flammable dust zone, the installer shall ensure that the cable entry maintains the dust-tightness (IP6X) of the enclosure.
- 

For explosionproof certifications:

---

**! WARNING**

---

Keep cover tight while circuits are energized unless area is known to be nonhazardous.

---

---

**! WARNING**

---

To prevent ignition of flammable or combustible atmospheres, disconnect power before servicing.

---



## 2. Installation

The following material provides information and procedures for installing the RTT80 Transmitter. For dimensional information, refer to DP 020-580.

Installation shall be carried out in accordance with the applicable code of practice (typically IEC 60079-14) by suitably trained personnel.

There are no special checking or maintenance conditions. All explosion-protected equipment should be periodically inspected in accordance with the applicable code of practice (typically IEC 60079-17). The interval between inspections should not normally exceed 3 years, unless justification for a longer interval is given.

With regard to explosion safety, it is not necessary to check for correct operation.

---

— **NOTE** —

Use a suitable thread sealant on all connections.

---

---

—  **CAUTION** —

Bare sensor or thermowell mounting to the 316 ss housing should not be used in high vibration areas.

---

---

—  **CAUTION** —

The RTT80 is only certified for use in ambient temperatures marked on the equipment and should not be used outside this range.

---

---

—  **CAUTION** —

The maximum process pressure indicated on the marking must not be exceeded.

---

---

—  **CAUTION** —

The maximum permitted ambient temperature of the RTT80 temperature transmitter is 80°C. To avoid the effects of process temperature and other thermal effects, care shall be taken to ensure that the electronics housing temperature does not exceed an ambient temperature of 80°C.

---

## Mounting

The transmitter is offered in a basic module package or with universal or dual compartment housing options. The basic transmitter module can be mounted on a flat surface or on a DIN rail using a simple clip. It is assumed that sufficient environmental protection is provided when a basic transmitter is used without a housing.

The transmitter is also offered with either a rugged universal housing, which accommodates the electronics and terminations in a single compartment, or a dual-compartment housing, which isolates and seals the wiring terminals from the electronics compartment. The transmitter in a field housing can be pipe mounted, surface mounted, mounted directly to a bare sensor, or thermowell mounted. See Figure 4 through Figure 8.

For extremely high process temperatures, a remote mounted sensor is recommended. Also, the mounting stability can influence how the sensor is attached to the transmitter. If the process vessel is highly insulated and the thermowell has considerable lagging, a remote mounted transmitter attached to a 50 mm (2 inch) pipe is recommended. When mounting the transmitter, take into account the necessary room to remove the cover.

## Requirements

1. For all versions, the sensor circuit is not infallibly galvanically isolated from the input circuit. However, the galvanic isolation between the circuits is capable of withstanding a test voltage of 500 Vac during 1 minute.
2. For RTT80-T with universal or dual compartment housings, be sure to use cable entries and blanking elements that are suitable for the application and are correctly installed.
3. For all versions with an ambient temperature  $\geq 60^{\circ}\text{C}$ , heat resistant cables with a rating of at least 20 K above the ambient temperature must be used.
4. For Type RTT80-T with Housing and Sensor Mounting Code BB, the transmitter must be mounted in an enclosure in order to provide a degree of ingress protection of at least IP20.
5. For Type RTT80-T with Housing and Sensor Mounting Code BB, the transmitter may only be installed in a potentially explosive atmosphere caused by the presence of combustible dust when mounted in a metal enclosure according to DIN 43729 that is providing a degree of protection of at least IP66/67 in accordance with EN 60529.

# Basic Module Mounting Options

*Figure 4. Basic Module Mounting Options (Housing and Sensor Mounting Code BB)*

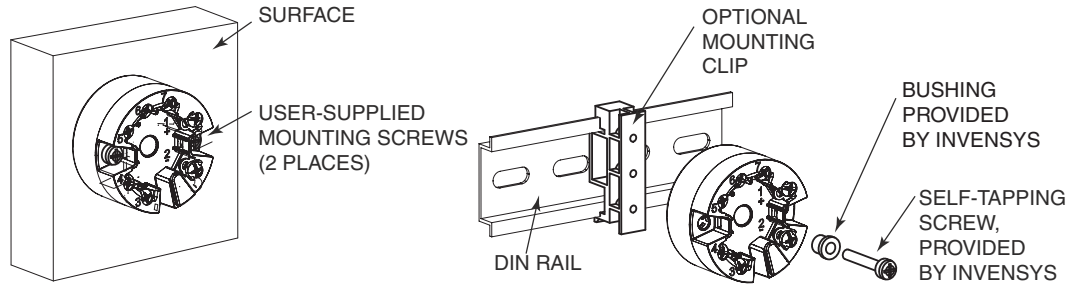

# Universal Housing Mounting Options

Figure 5. Universal Housing Mounting Options (Housing and Sensor Mounting Codes SS, TT, LL, MM, WW, and YY)

UNIVERSAL HOUSING FOR SURFACE OR PIPE MOUNT WITH REMOTE SENSOR

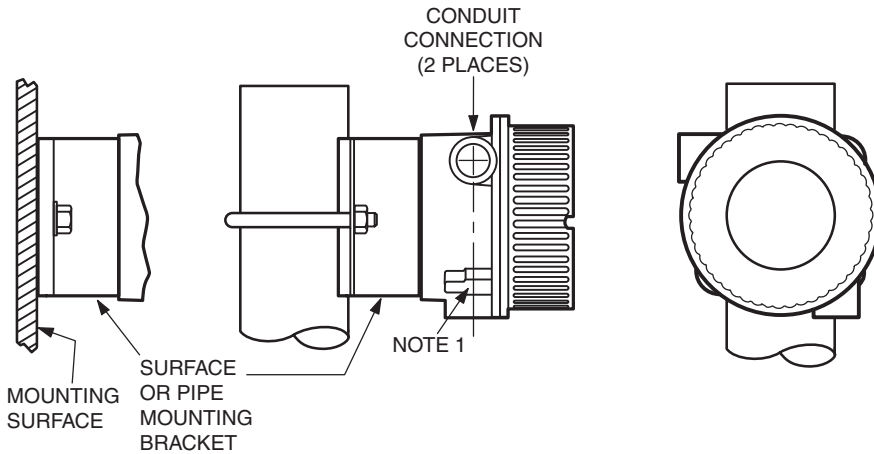

HOUSING CODES  
 SS = ALUMINUM  
 TT = 316 ss

NOTE 1  
 EXTERNAL COVER  
 LOCK AND GROUND  
 SCREW WHEN  
 APPLICABLE.

UNIVERSAL HOUSING WITH INTEGRAL SENSOR

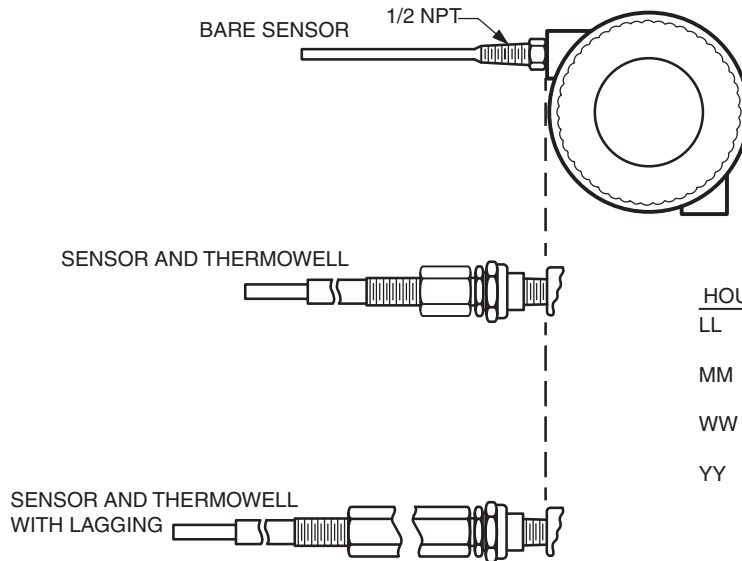

HOUSING CODES  
 LL = ALUMINUM HOUSING  
 FOR SENSOR AND WELL  
 MM = 316 ss HOUSING  
 FOR SENSOR AND WELL  
 WW = ALUMINUM HOUSING  
 WITH BARE SENSOR  
 YY = 316 ss HOUSING  
 WITH BARE SENSOR

# Dual Compartment Housing Mounting Options

*Figure 6. Dual Compartment Housing Mounting Options: Remote Sensor (Housing and Sensor Mounting Codes GG, HH, QQ, and RR)*

DUAL COMPARTMENT HOUSING FOR SURFACE OR PIPE MOUNT WITH REMOTE SENSOR

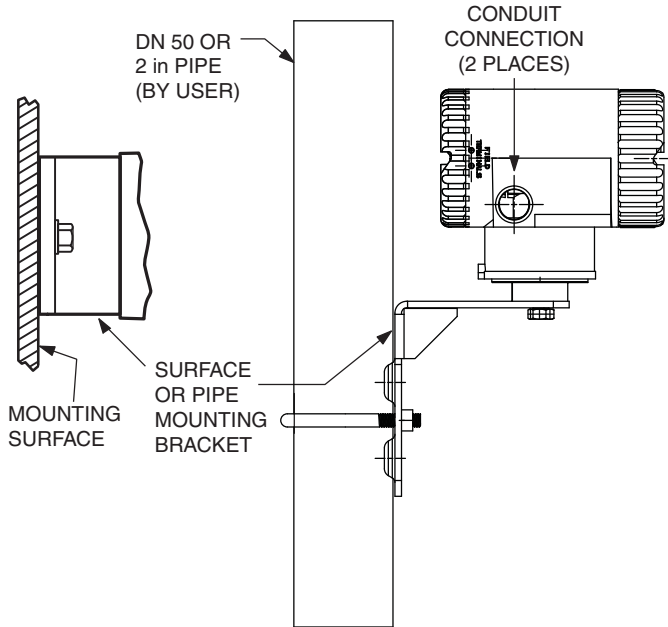

HOUSING CODES

- GG = ALUMINUM M20 HOUSING FOR REMOTE SENSOR
- HH = 316 ss M20 HOUSING FOR REMOTE SENSOR
- QQ = ALUMINUM 1/2 NPT HOUSING FOR REMOTE SENSOR
- RR = 316 ss 1/2 NPT HOUSING FOR REMOTE SENSOR

*Figure 7. Dual Compartment Housing Mounting Options: Integral Sensor (Housing and Sensor Mounting Codes CC, DD, EE, FF, JJ, KK, NN, and PP)*

**DUAL COMPARTMENT HOUSING WITH INTEGRAL SENSOR AND/OR SENSOR AND THERMOWELL**

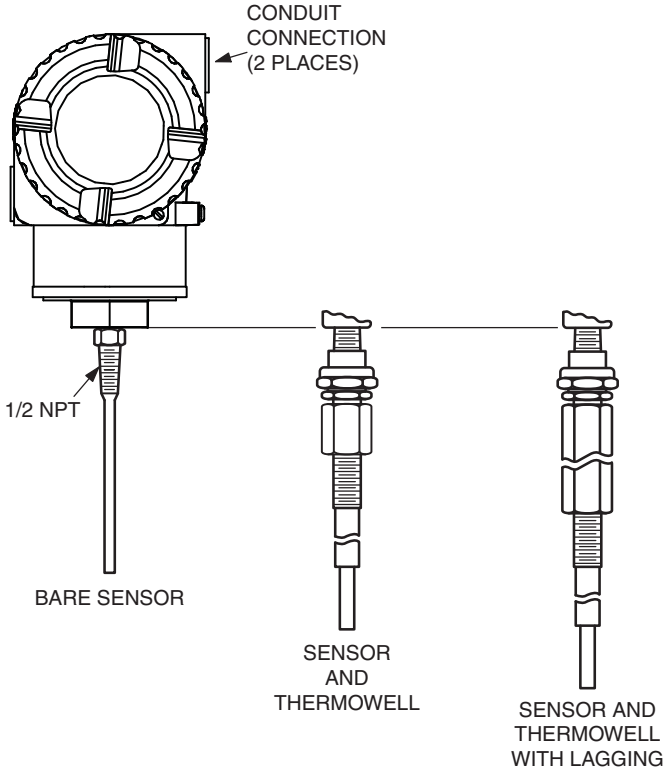

HOUSING CODES

- CC = ALUMINUM M20 HOUSING WITH BARE SENSOR
- DD = 316 SS M20 HOUSING WITH BARE SENSOR
- EE = ALUMINUM M20 HOUSING WITH SENSOR AND THERMOWELL
- FF = 316 SS M20 HOUSING WITH SENSOR AND THERMOWELL
- JJ = ALUMINUM 1/2 NPT HOUSING WITH BARE SENSOR
- KK = 316 SS 1/2 NPT HOUSING WITH BARE SENSOR
- NN = ALUMINUM 1/2 NPT HOUSING WITH SENSOR AND THERMOWELL
- PP = 316 SS 1/2 NPT HOUSING WITH SENSOR AND THERMOWELL

## Thermowell Mounting

*Figure 8. Thermowell Mounting (Dual Compartment Housing Shown)*

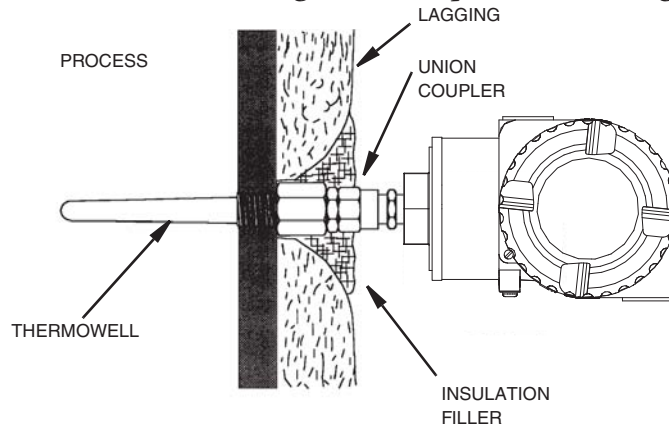

## Cover Locks

A cover lock is provided as standard with certain agency certifications and as part of the Custody Transfer Lock and Seal option. The type of lock varies with the housing used.

### Universal Housing Cover Locks

To lock the cover on the universal housing:

1. Tighten the cover on the housing until the flange on the cover comes into contact with the flange on the housing.
2. Place the clamp as shown below and tighten the clamp screw.
3. Insert the seal wire through the clamp and crimp the seal if applicable.

*Figure 9. Universal Housing Cover Lock*

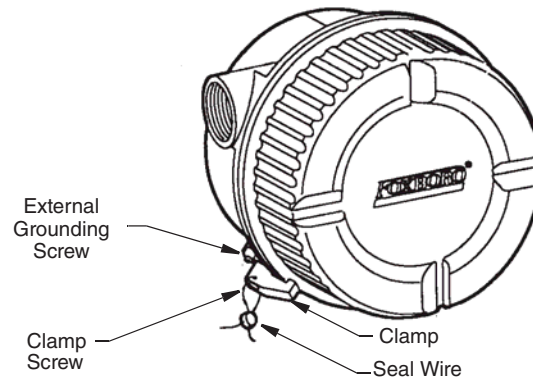

## Dual Compartment Housing Cover Locks

To lock the covers on the dual compartment housing:

1. Tighten each cover on the housing until the flange on the cover comes into contact with the flange on the housing.
2. Tighten the locking screw as shown below and tighten the clamp screw.
3. Insert the seal wire through the clamp and crimp the seal if applicable.

*Figure 10. Dual Compartment Housing Cover Locks*

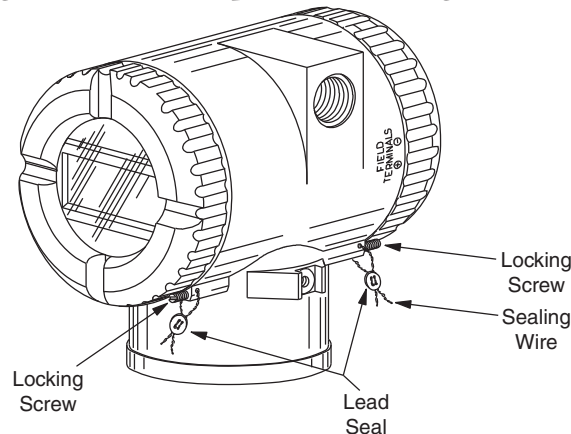

## Wiring

Your transmitter must be installed to meet all local installation regulations, such as hazardous location requirements and electrical wiring codes. Persons involved in the installation must be trained in these code requirements. To maintain agency certification, your transmitter must also be installed in accordance with the agency requirements.

---

### **! WARNING**

To maintain IEC IP66/67 and NEMA Type 4X protection on transmitters with universal housings, any unused conduit opening must be plugged with a metal plug. In addition, the threaded housing cover must be installed. Hand tighten the cover so that the O-ring is fully captured, making sure that the flange of the cover comes into contact with the flange of the housing

---



---

### **NOTE**

It is recommended that you use transient/surge protection in installations prone to high levels of electrical transients and surges.

---



## Input Connections

There are seven terminals on the basic module for input and output connections. Terminals 1 and 2 are for bus power and measurement output and terminals 3 through 7 are for RTD, TC, ohm, or mV sensor inputs. See Figure 11.

In the dual-compartment housing with remote sensor, the bus and sensor connections are made through the terminal block in the customer connection side of the housing. The terminals are identified with the same numbers as the module connections and the wires are color-coded as indicated in Figure 12.

*Figure 11. Input Connections on the Basic Module and Universal Housing*

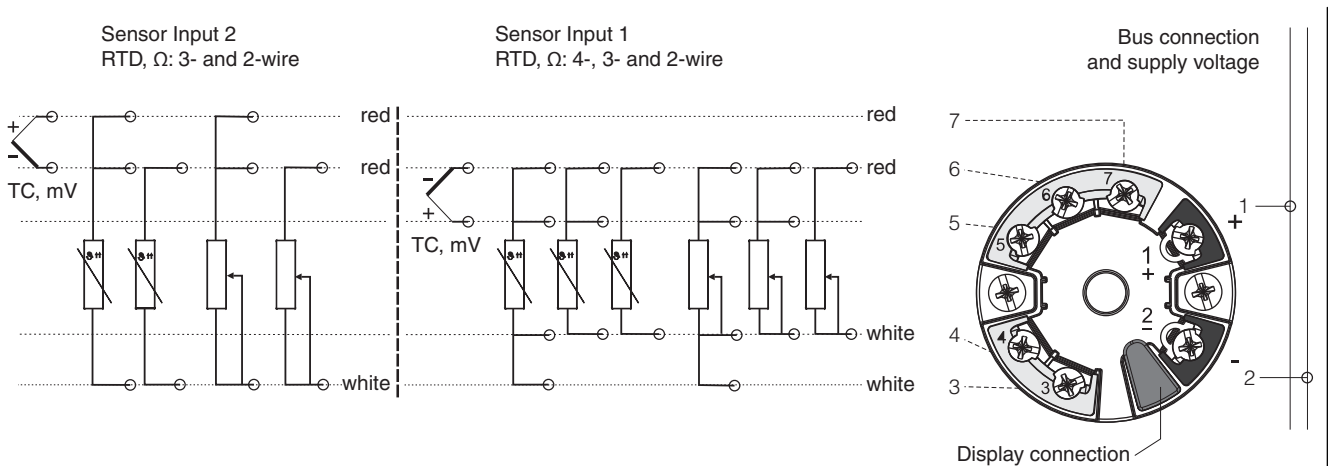

*Figure 12. Dual Compartment Housing Wiring from the Terminal Block to the Module*

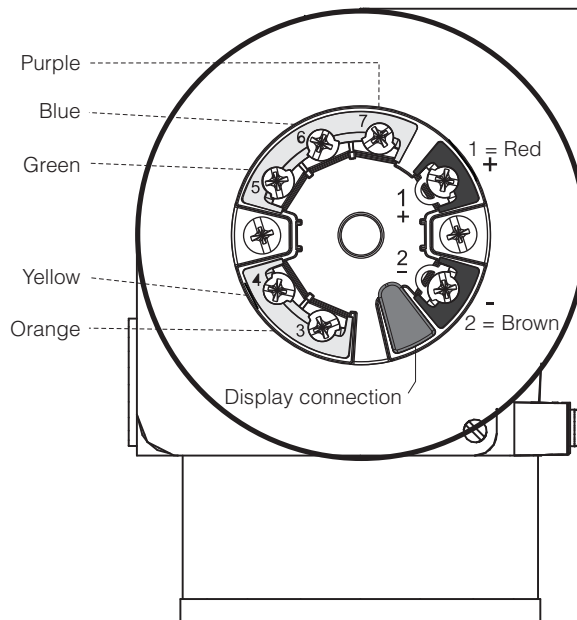

The following connection combinations are possible when both sensor inputs are assigned:

		Sensor 1			
		2-wire RTD	3-wire RTD	4-wire RTD	Thermocouple
Sensor 2	2-wire RTD	Ok	Ok	N/A	Ok
	3-wire RTD	Ok	Ok	N/A	Ok
	Thermocouple	Ok	Ok	Ok	Ok

## Loop Wiring

When wiring the transmitter, the supply voltage and loop load must be within specified limits. The supply output load vs. voltage relationship is:

$$R_{b \text{ max}} = (U_{b \text{ max}} - 11V) / 0.023 \text{ A (current output) and is shown in Figure 13.}$$

Any combination of supply voltage and loop load resistance in the shaded area can be used. To determine the loop load resistance (transmitter output load), add the series resistance of each component in the loop, excluding the transmitter. The power supply must be capable of supplying 23 mA of loop current.

**NOTE**

The maximum voltage is 30 V dc for transmitters certified as intrinsically safe.

*Figure 13. Supply Voltage and Loop Load*

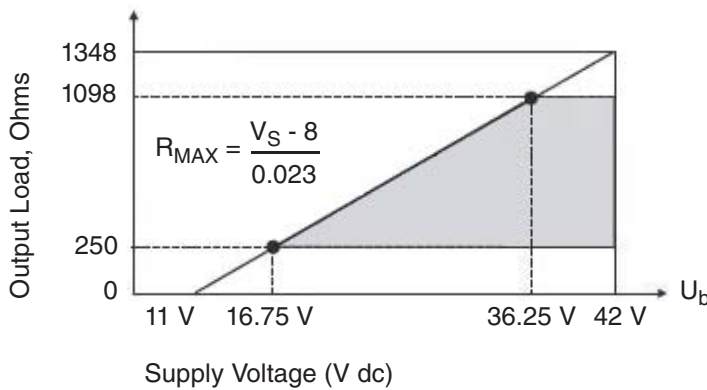

**NOTE**

The transmitter will function with an output load less than 250 Ω provided that a HART Communicator or PC-based Configurator is not connected to it. Use of a HART Communicator or PC-based Configurator requires 250 Ω minimum load.

To wire one or more transmitters to a power supply, proceed with the following steps.

1. Remove the cover from the transmitter field terminals compartment.
2. Run signal wires (0.50 mm<sup>2</sup> or 20 AWG, typical) to the transmitter. Use twisted single pair to protect the 4 to 20 mA output and/or remote communications from electrical noise. Maximum recommended length for signal wires is:
  - ◆ 3050 m (10,000 ft) **using single pair cable** and adhering to requirements of HART physical layer implementation defined in HART Document HCF\_SPEC-53. Use CN=1 when calculating maximum lengths.
  - ◆ 1525 m (5000 ft) in a multidrop (15 devices maximum) mode. Screened (shielded) cable could be required in some locations.

---

**NOTE**

Do not run transmitter wires in same conduit as mains (ac power) wires.

---

3. If shielded cable is used, earth (ground) the shield at the power supply **only**. Do not ground the shield at the transmitter.
4. If housing is used, plug any unused conduit connection with a metal plug.
5. Connect an earth (ground) wire to the earth terminal in accordance with local practice.

---

**! CAUTION**

If the signal circuit must be earthed (grounded), it is preferable to do so at the negative terminal of the dc power supply. To avoid errors resulting from earth loops or the possibility of short-circuiting groups of instruments in a loop, there should be only one earth in a loop.

---

6. Connect receivers (such as controllers, recorders, indicators) in series with power supply and transmitter as shown in Figure 14.
7. If a housing is used, install the cover onto the housing.
8. If wiring additional transmitters to the same power supply, repeat Steps 1 through 7 for each additional transmitter. The setup with multiple transmitters connected to a single power supply is shown in Figure 15.
9. The HART Communicator can be connected in the loop between the transmitter and the power supply as shown in the two figures below. Note that a minimum of 250 Ω must separate the power supply from the HART Communicator.

Figure 14. Transmitter Loop Wiring

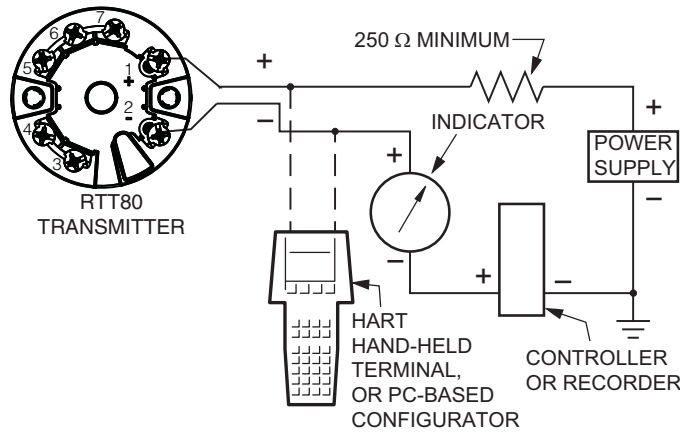
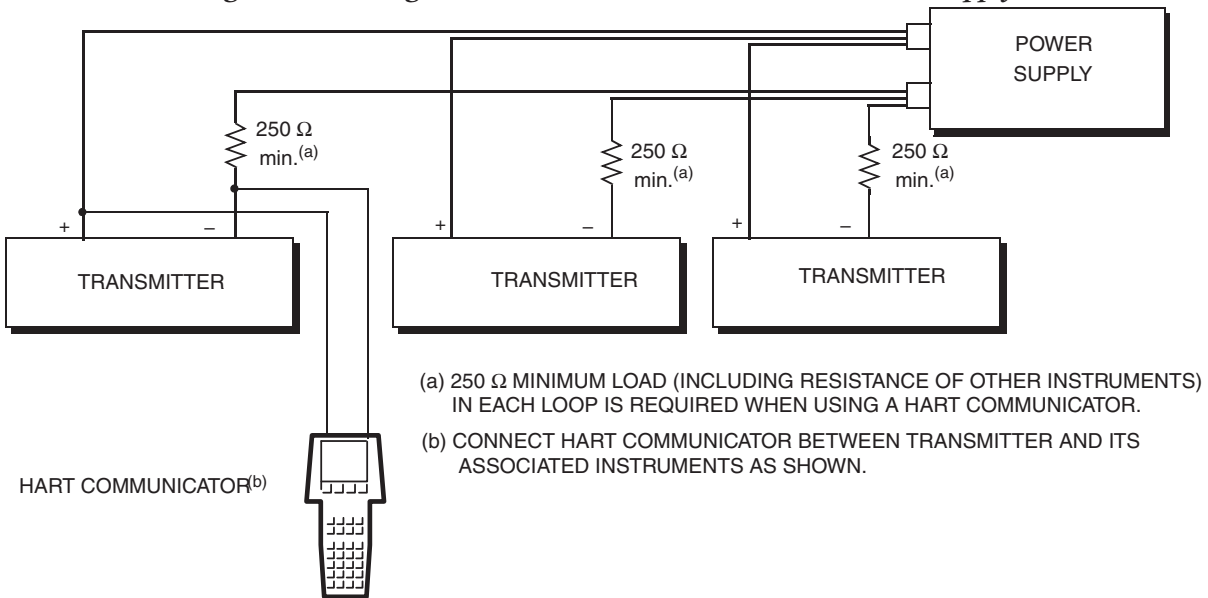

Figure 15. Wiring Several Transmitters to a Common Power Supply



## Multidrop Communication

“Multidropping” refers to the connection of several transmitters to a single communications transmission line. Communications between the host computer and the transmitters takes place digitally with the analog output of the transmitter deactivated. With the HART Version 6 communications protocol, up to 15 transmitters can be connected on a single twisted pair of wires or over leased telephone lines.

The application of a multidrop installation requires consideration of the update rate necessary from each transmitter, the combination of transmitter models, and the length of the transmission line. Multidrop installations are not recommended where Intrinsic Safety is a requirement. Communication with the transmitters can be accomplished with any HART compatible modem and a host implementing the HART protocol. Each transmitter is identified by a unique address (1-15) and responds to the commands defined in the HART protocol.

Figure 16 shows a typical multidrop network. Do not use this figure as an installation diagram. Contact the HART Communications Foundation, visit <http://www.hartcomm.org/>, with specific requirements for multidrop applications.

*Figure 16. Typical Multidrop Network*

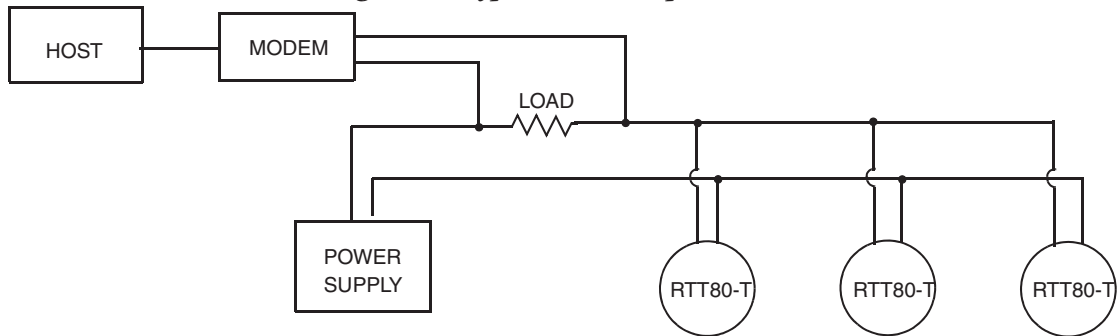



# 3. Configuration and Operation

## Configuration

### Hardware Settings

DIP switches on the back of the optional display can be used to set the write protection of the display and to switch the orientation of the display by 180 degrees. See Figure 17 below.

Figure 17. Display DIP Switches

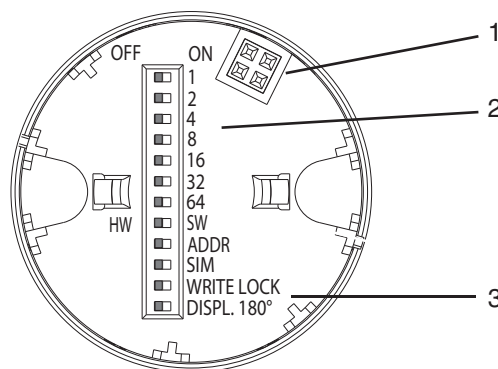

- 1 Connector to RTT80 transmitter
- 2 DIP switches 1 through 64, HW/SW, ADDR ACTIVE, SIM – Factory use only
- 3 WRITE LOCK, DISP 180° - Set to ON/OFF

## User Roles

Configuration of the RTT80 is structured to accommodate three different user roles:

- ◆ Operator – contains all of the parameters that are required for operation. Allows configuration of the measured value display and reading of measurements.
- ◆ Maintenance Technician – contains all of the parameters required for commissioning and troubleshooting.
- ◆ Expert – contains the parameters for all the device functions including high order functions that are not addressed above.

### Display/Operation – User role: Operator

This menu structure allows a user to define what will appear on the optional LCD display.

- ◆ Display Interval: Define in seconds the interval a measured value is displayed if more than one measured value is displayed.
- ◆ Format Display: Define the format of the display – Value Only or Value with Bargraph.

- ◆ Value 1 Display: Define the value to be displayed as the first value – selections include Process Value, Sensor 1<sup>(1)</sup> Value, Output Current, Percent of Range or Device Temperature.
- ◆ Decimal Places 1: Define the number of characters displayed after the decimal point – selections include X, X.X, X.XX, X.XXX, X.XXXX, or Automatic, based on the number of characters contained in the measured value. “Automatic” displays the maximum number of decimal places possible based on the measurement.
- ◆ Value 2 Display: Define the value to be displayed as the second value – selections include Off, Process Value, Sensor 1<sup>(1)</sup> Value, Output Current, Percent of Range, or Device Temperature.
- ◆ Decimal Places 2: Define the number of characters displayed after the decimal point – selections include X, X.X, X.XX, X.XXX, X.XXXX or Automatic, based on the amount of characters contained in the measured value. “Automatic” displays the maximum number of decimal places possible based on the measurement.
- ◆ Value 3 Display: Define the value to be displayed as the third value – selections include Off, Process Value, Sensor 1<sup>(1)</sup> Value, Output Current, Percent of Range, or Device Temperature.
- ◆ Decimal Places 3: Define the number of characters displayed after the decimal point – selections include X, X.X, X.XX, X.XXX, X.XXXX or Automatic, based on the number of characters contained in the measured value. “Automatic” displays the maximum number of decimal places possible based on the measurement.

### *Setup – User role: Maintenance Technician*

This menu structure allows a user to define specifics related to the temperature measurement.

- ◆ Unit: Defines the engineering unit for the transmitter output – selections include degC, degF, K, degR, Ohm and mV.
- ◆ Sensor Type 1: Defines the type of sensor connected to the input 1 terminals – selections include all sensor types listed in Table 2 on page 11 plus “No Sensor”.
- ◆ Connection Type 1: When RTD sensor is specified as Sensor Type 1, allows the user to define 2-wire, 3-wire or 4-wire connections.
- ◆ 2-wire Compensation 1: When 2-wire RTD is selected as Input 1 type, allows a user to specify a resistance value for 2-wire compensation. User input from 0 to 30 Ohms.
- ◆ Reference Junction 1: When thermocouple is selected as Input 1 type, allows a user to define the source of the cold junction compensation – selections include No Compensation, Internal Measurement, Fixed Value, and Sensor 2 Value. If Sensor 2 Value is selected, Sensor Type 2 must be configured.
- ◆ RJ Preset Value 1: If Reference Junction 1 is selected to be fixed Value, allows the user to specify the reference junction value between -50 and 85°C.
- ◆ Sensor Type 2: Defines the type of sensor connected to the input 2 terminals – selections include all sensor types listed in Table 2 on page 11 plus “No Sensor”.

---

1. Also Applies to Sensor 2 when configured for dual input.



- ◆ Connection Type 2: When RTD sensor is specified as Sensor Type 1, allows the user to define 2-wire or 3-wire connection.
- ◆ 2-wire Compensation 2: When 2-wire RTD is selected as Input 2 type, allows a user to specify a resistance value for 2-wire compensation. User input from 0 to 30 Ohms.
- ◆ Reference Junction 2: When thermocouple is selected as Input 2 type, allows a user to define the source of the cold junction compensation – selections include No Compensation, Internal Measurement, and Fixed Value.
- ◆ RJ Preset Value 2: If Reference Junction 2 is selected to be Fixed Value, allows the user to specify the reference junction value between -50 and 85°C.
- ◆ Assign Current Output (PV): Defines the measurement that will be the Primary Value and drive the 4 to 20 mA output of the transmitter – selections include:
  - ◆ Sensor 1 measured value
  - ◆ Sensor 2 measured value
  - ◆ Device temperature
  - ◆ Average of the two measured value
  - ◆ Difference between Sensor 1 and Sensor 2
  - ◆ Sensor 1 value with Sensor 2 backup – If Sensor 1 fails, Sensor 2 will automatically become the PV
  - ◆ Sensor switching – If the value exceeds a configured threshold for Sensor 1, Sensor 2 will become the PV. The PV will switch back to Sensor 1 if the measured value diminishes to 2K below the configured threshold value
  - ◆ Average of the two measured value with backup – the PV is an average but if one of the sensors fails, it becomes the value of the other sensor
- ◆ Lower Range Value (LRV): Defines the Lower Range Value of the measurement and relates to the 4 mA analog output value.
- ◆ Upper Range Value (URV): Defines the Upper Range Value of the measurement and relates to the 20 mA analog output value.
- ◆ Advanced Setup: Allows for the setting of additional parameters as follows:
  - ◆ Device Tag – Sets the HART 32 character device tag. This is displayed in the header of the optional display.
  - ◆ Access Code – Factory code – not for field use.
  - ◆ Access Status Tooling (Access level) – shows access authorization to device parameters. Operator or Service access.
  - ◆ Device Temperature Alarm – allows a user to select the device reaction to out of operating temperature limits – selections include Off, Out of Specification (S) or Failure (F).
  - ◆ Locking Status – shows if the DIP switch on the optional display is set for write protection lockout.
  - ◆ Sensor:

- ◆ Sensor 1<sup>(1)</sup> offset (offset value in engineering units) – sets zero point correction to measured value from -10.0 to +10.0.
- ◆ Corrosion Detection Mode – allows a user to select the device reaction when corrosion of the sensor cables is detected – selections include failure (F) or maintenance required (M).
- ◆ Drift/Difference Mode – when in 2-channel operation allows a user to select an alarm for measurements exceeding or dropping below the set point – selections include Off, Out Band (value exceeds set point), or In Band (value drops below set point).
- ◆ Drift/Difference Alarm Category – when Drift/Difference Mode is set for Out Band or In Band, allows a user to select the device reaction to a Drift/Difference alarm – selections include Out of Specification (S), Maintenance Required (M), or Failure (F).
- ◆ Drift/Difference Set Point – allows a user to define the maximum permissible measured value deviation between Sensor 1 and Sensor 2 which results in Drift/Difference detection. Permissible values are between 1.0 and 999.0.
- ◆ Sensor Switch Set Point – allows a user to define the threshold value for sensor switching. See Setup > Advanced Setup > Assign Current Output.
- ◆ Current Output:
  - ◆ Output Current (read only)
  - ◆ Measuring Mode (standard or inverse – 4 to 20 or 20 to 4 mA)
  - ◆ Out of Range Categorization – allows a user to select the device reaction to measurement value outside the set measuring range – Out of Specification (S), Maintenance Required (M), or Failure (F)
  - ◆ Failure Mode – Min, Max (Downscale or Upscale)
  - ◆ Failure Current – if Max Failure Mode is selected, allows a user to define the mA level that conveys a failure – 21.5 to 23.0 mA
  - ◆ Current Trim, 4 mA – adjusts the current output at the lower end of the measuring range – user input 3.85 to 4.15 mA
  - ◆ Current Trim, 20 mA – adjusts the current output at the upper end of the measuring range – user input 19.85 to 20.15 mA

### *Diagnostics – User role: Maintenance Technician*

This menu structure provides diagnostic information and allows the user to set diagnostic preferences.

- ◆ Actual Diagnostic 1: (Read only) Conveys any diagnostic message that may currently be active for sensor input 1. See diagnostic codes in Chapter 4, “Maintenance”. If more than one diagnostic is active, the highest priority diagnostic will be shown.
- ◆ Remedy Information: (Read only) Displays the suggested remedial action for the current diagnostic message.

---

1. Also Applies to Sensor 2 when configured for dual input.

- ◆ Previous Diagnostic 1: (Read only) Conveys the last diagnostic message with the highest priority. See diagnostic codes later in Chapter 4, “Maintenance”.
- ◆ Operating Time: (Read only) Time in hours that the device has been in operation.
- ◆ Diagnostic List: (Read only) Status of 3 channels and counts of diagnostic messages with the highest priority.
  - ◆ Actual Diagnostics Count – displays the number of diagnostic messages currently pending.
  - ◆ Actual Diagnostics – displays the 3 current diagnostics with the highest priority.
  - ◆ Actual Diagnostic Channel – displays the sensor input related to current diagnostic messages.
- ◆ Event logbook: (Read only) Listing of historical diagnostic errors with mapping to input.
  - ◆ Previous Diagnostics (1 to 5) – displays the diagnostic messages that occurred in the past, up to 5 with the highest priority.
  - ◆ Previous Diagnostic Channel – displays the possible sensor input related to the previous diagnostic messages.
- ◆ Device Information:
  - ◆ Device Tag: Allows a user to set the tag (Also see Advanced Setup > Device Tag)
  - ◆ Serial number: (Read only)
  - ◆ Firmware Version (Read only) format: xx.yy.zz
  - ◆ Device name (Read only) RTT80
  - ◆ Order Code (Read only) RTT80
  - ◆ Configuration Counter (Read only) – counts changes to the device configuration
- ◆ Measured Values: (Read only) Measurement of sensor inputs, internal electronics temperature and minimum/maximum value.
  - ◆ Sensor 1 Value<sup>(1)</sup>
  - ◆ Device Temperature
  - ◆ Min/Max Values:
    - ◆ Sensor 1<sup>(1)</sup> min. value
    - ◆ Sensor 1<sup>(1)</sup> max value
    - ◆ Reset sensor min/max values
    - ◆ Device temperature max value
    - ◆ Device temperature min value
    - ◆ Reset device temperature min/max values
- ◆ Simulation: Allows a user to turn simulation on or off and set the mA output value for simulation

---

1. Also Applies to Sensor 2 when configured for dual input.

- ◆ Simulation Current Output (On/Off)
- ◆ Value Current Output (Enter mA value)
- ◆ Device Reset: Allows a user to define the reset mode of the transmitter
  - ◆ Not Active
  - ◆ Restart Device – device is restarted but configuration is not changed
  - ◆ To Delivery Settings – same as Factory Settings
  - ◆ To Factory Settings – reset to the original factory setting
- ◆ HART Diagnostics: See HART diagnostics in Chapter 4, “Maintenance”.

### *Expert – User role: Expert*

This menu structure allows a user to enable additional configuration of the RTT80 as defined below:

- ◆ Enter Access Code: See Setup > Advanced Setup > Enter Access Code
- ◆ Access Status Tool: See Setup > Advanced Setup > Access Status Tooling
- ◆ Locking Status: See Setup > Advanced Setup > Locking Status
- ◆ System: Grants access to system information. In some cases provides alternative access to set transmitter configuration
  - ◆ Unit – see Setup > Unit
  - ◆ Damping – allows a user to set measurement damping in seconds from 0 to 120. Provides an exponential delay to fluctuations in measured value as specified by the damping value.
  - ◆ Alarm Delay – allows a user to set time in seconds before an alarm is broadcast
  - ◆ Mains Filter – allows a user to set the mains filter to 50 Hz or 60 Hz
  - ◆ Device Temperature Alarm – see Setup > Advanced Setup > Device Temperature Alarm
  - ◆ Display: Allows the user to configure the optional LCD display. (See “Display/Operation – User role: Operator” on page 31 above for selections.)

- ◆ Sensor: Allows a user to set sensor configuration parameters and read sensor information. In some cases provides alternative access to transmitter configuration. (See “Setup – User role: Maintenance Technician” on page 32 above)
  - ◆ Sensor 1<sup>(1)</sup>
    - ◆ Sensor Type 1<sup>(1)</sup>
    - ◆ Connection Type 1<sup>(1)</sup>
    - ◆ 2-wire Compensation 1<sup>(1)</sup>
    - ◆ Reference Junction 1<sup>(1)</sup>
    - ◆ RJ Preset Value 1<sup>(1)</sup>
    - ◆ Sensor Offset 1<sup>(1)</sup> – see Setup > Advanced Setup > Sensor > Sensor Offset
    - ◆ Sensor 1<sup>(1)</sup> Low Limit
    - ◆ Sensor 1<sup>(1)</sup> Upper Limit
    - ◆ Sensor 1<sup>(1)</sup> Serial Number – Allows a user to input a serial number for the sensor<sup>(2)</sup>
    - ◆ Sensor Trimming – Factory trim settings or user trim settings
  - ◆ Diagnostic Settings
    - ◆ Sensor offset 1<sup>(1)</sup> – see Setup > Advanced Setup > Sensor > Sensor Offset 1
    - ◆ Corrosion Detection – see Setup > Advanced Setup > Sensor > Corrosion Detection
    - ◆ Drift/Difference Mode – see Setup > Advanced Setup > Sensor > Drift/Difference Mode
    - ◆ Drift/Difference Alarm Category – see Setup > Advanced Setup > Sensor > Drift/Difference Alarm Category
    - ◆ Drift/Difference Set Point – see Setup > Advanced Setup > Sensor > Drift/Difference Set Point
    - ◆ Sensor Switch Set Point – see Setup > Advanced Setup > Sensor > Sensor Switch Set Point.
    - ◆ Calibration Counter Start – allows a user to turn the calibration counter on or off or reset the counter.
    - ◆ Calibration Counter Alarm Category – allows a user to define whether a calibration alarm is manifested as Maintenance Required (M) or Failure (F).
    - ◆ Calibration Counter Start Value – allows the user to define the number of days for calibration countdown. Permissible values are between 0 and 365 days.

---

1. Also Applies to Sensor 2 when configured for dual input.

2. Sensor serial number fields are 12 characters long. All characters must be filled in. Open field beyond the serial number must be filled in with spaces. For example, sensor serial number 123456 must be followed by 6 spaces.

- ◆ Calibration Countdown – (read only) shows the remaining days on the calibration counter.
- ◆ Output: A menu structure that defines the characteristics of the transmitter output. In some cases provides alternative access to transmitter configuration.
  - ◆ Output Current – see Setup > Advanced Setup > Current Output > Output Current.
  - ◆ Measuring Mode: allows a user to invert the output signal. Selections are Standard or Inverse.
  - ◆ Lower Range Value – see Setup > Lower Range Value.
  - ◆ Upper Range Value – see Setup > Upper Range Value.
  - ◆ Out of Range Category – see Setup > Advanced Setup > Current Output > Out of Range Category.
  - ◆ Failure Mode – see Setup > Advanced Setup > Current Output > Failure Mode.
  - ◆ Failure Current – see Setup > Advanced Setup > Current Output > Failure Current.
  - ◆ Current Trimming 4 mA – see Setup > Advanced Setup > Current Output > Current Trimming 4 mA.
  - ◆ Current Trimming 20 mA – see Setup > Advanced Setup > Current Output > Current Trimming 20 mA.
- ◆ Communication: A menu structure that defines the communication capabilities of the RTT80 transmitter.

### **HART Configuration**

- ◆ Device Tag – 32 Characters
- ◆ HART Short Tag – 8 Characters
- ◆ HART Address – 0 to 15 (HART 5) or 0 to 63 (HART 6)
- ◆ Number of Preambles – 2 to 20
- ◆ Burst Mode (On/Off)
- ◆ Burst Command (Command 1, 2, 3, 9 or 33) – selects the command whose response is sent to the HART master in burst mode
  - ◆ Command 1: Primary variable
  - ◆ Command 2: Current and main measured value as %
  - ◆ Command 3: Current and dynamic HART variables
  - ◆ Command 9: Dynamic variables and status
  - ◆ Command 33: Dynamic variables and units
- ◆ Burst Slot 0 through 3 – used only in burst mode for PV, SV, TV and QV. Allowable selections are listed below:
  - ◆ Sensor 1

- ◆ Sensor 2
- ◆ Device Temperature
- ◆ Average of Sensor 1 and Sensor 2
- ◆ Difference between Sensor 1 and Sensor 2
- ◆ Sensor 1 with Sensor 2 backup
- ◆ Sensor Switching
- ◆ Average with Backup
- ◆ Configuration Changed – shows the change of configuration via a primary or a secondary master (Primary Master On, Secondary Master Off)
- ◆ Reset Configuration Changed flag

### HART Info

- ◆ Device Type – shows the device type that is registered with the HART Communication Foundation – a two-digit hexadecimal number
- ◆ Device Revision – the revision of the device that is registered with the HCF
- ◆ HART Revision – the HART revision of the device
- ◆ HART Descriptor – allows the user to define a description for the device - 32 character limit.
- ◆ HART Message – allows a user to define a message that is sent from the device via the HART digital protocol when requested.
- ◆ RevSW – software revision of the device
- ◆ HART Date Code – allows a user to define a date. Format is YYYY-MM-DD.

### HART Output

- ◆ Assign Current Output – see Setup > Assign Current Output
- ◆ PV – displays the Primary Variable (PV)
- ◆ Assign SV – allows a user to assigned a measurement to the HART Secondary Variable (SV)
- ◆ SV – displays the HART SV
- ◆ Assign TV - allows a user to assigned a measurement to the HART Third Variable (TV)
- ◆ TV – displays the HART TV
- ◆ Assign QV – allows a user to assign a measurement to the HART Quarternary Value (QV)
- ◆ QV – displays the HART QV
- ◆ Diagnostics: A menu structure that provides information on diagnostic status and device information. In some cases provides alternative access to transmitter configuration.

- ◆ Actual Diagnostics 1 – see Diagnostics > Actual Diagnostics
- ◆ Remedy Information - see Diagnostics > Remedy Information
- ◆ Previous Diagnostic 1 – see Diagnostics > Previous Diagnostic 1
- ◆ Operating Time: - see Diagnostics > Operating Time
- ◆ Diagnostics List
  - ◆ Actual Diagnostic Count – see Diagnostics > Diagnostic List > Actual Diagnostics Count
  - ◆ Actual Diagnostics – see Diagnostics > Diagnostic List > Actual Diagnostics
  - ◆ Actual Diagnostic Channel – see Diagnostics > Diagnostic List > Actual Diagnostic Channel
- ◆ Event Logbook – Diagnostics > Event Logbook
- ◆ Device Information
  - ◆ Device Tag – see Diagnostics > Device Information > Device Tag
  - ◆ Serial Number - see Diagnostics > Device Information > Serial Number<sup>(1)</sup>
  - ◆ Firmware Version - see Diagnostics > Device Information > Firmware Version
  - ◆ Device Name - see Diagnostics > Device Information > Device Name
  - ◆ Order Code - see Diagnostics > Device Information > Order Code
  - ◆ Ext Order Code – extended order code – RTT80-T
  - ◆ Ext Order Code 2 – not used
  - ◆ Ext Order Code 3 – not used
  - ◆ ENP Version – shows the Electronic Nameplate (read only) – the format is *xx.yy.zz*
  - ◆ Device Revision – see Expert > Communication > HART Info > Device Revision
  - ◆ Manufacturer ID – shows the manufacturer ID number (20)
  - ◆ Manufacturer - Foxboro
  - ◆ Hardware Revision – shows the hardware revision number in the format *xx.yy.zz*
  - ◆ Configuration Counter - see Diagnostics > Device Information > Configuration Counter
- ◆ Measured Values
  - ◆ Sensor 1<sup>(2)</sup> Value – see Diagnostics > Measured Values > Sensor 1 Value
  - ◆ Sensor 1<sup>(2)</sup> Raw Value – displays the non-linearized mV or Ohm value of Sensor 1 input

---

1. Sensor serial number fields are 12 characters long. All characters must be filled in. Open field beyond the serial number must be filled in with spaces. For example, sensor serial number 123456 must be followed by 6 spaces.

2. Also Applies to Sensor 2 when configured for dual input.



- ◆ Device Temperature – see Diagnostics > Measured Values > Device Temperature
- ◆ Min/Max Values
  - ◆ Sensor 1 Minimum – see Diagnostics > Measured Values > Min/Max Values > Sensor 1 Min Value
  - ◆ Sensor 1 Maximum - see Diagnostics > Measured Values > Min/Max Values > Sensor 1 Max Value
  - ◆ Sensor 2 Minimum - see Diagnostics > Measured Values > Min/Max Values > Sensor 2 Min Value
  - ◆ Sensor 2 Maximum - see Diagnostics > Measured Values > Min/Max Values > Sensor 2 Max Value
  - ◆ Reset Sensor Min/Max Values - see Diagnostics > Measured Values > Min/Max Values > Reset Sensor Min/Max Values
  - ◆ Device Temperature Min - see Diagnostics > Measured Values > Min/Max Values > Device Temperature Min
  - ◆ Device Temperature Max - see Diagnostics > Measured Values > Min/Max Values > Device Temperature Max
  - ◆ Reset Device Temp Min/Max Values - see Diagnostics > Measured Values > Min/Max Values > Reset Device Temperature Min/Max
- ◆ Simulation
  - ◆ Simulation Current Output – see Diagnostics > Simulation > Simulation Current Output
  - ◆ Value Current Output - see Diagnostics > Simulation > Value Current Output
- ◆ Device Reset – see Diagnostics > Device Reset > Device Reset

## Operation

The RTT80 is operated as a HART Version 6 compliant device. Measurement may be communicated either as point-to-point or as a multi-drop transmitter. Communications may be digital using HART commands or primary value via 4 to 20 mA output.

## Local Display

The optional display contains several pieces of information as illustrated in Figure 18 below:

Figure 18. Display Information

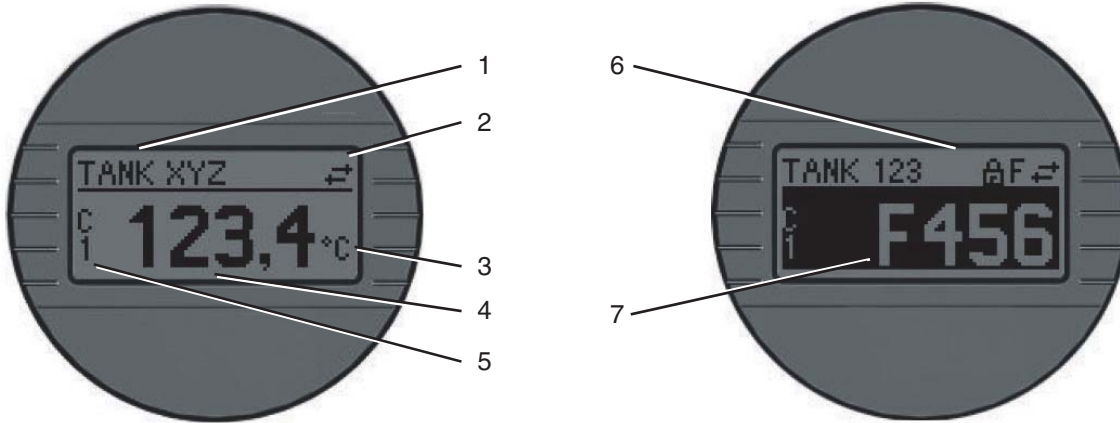
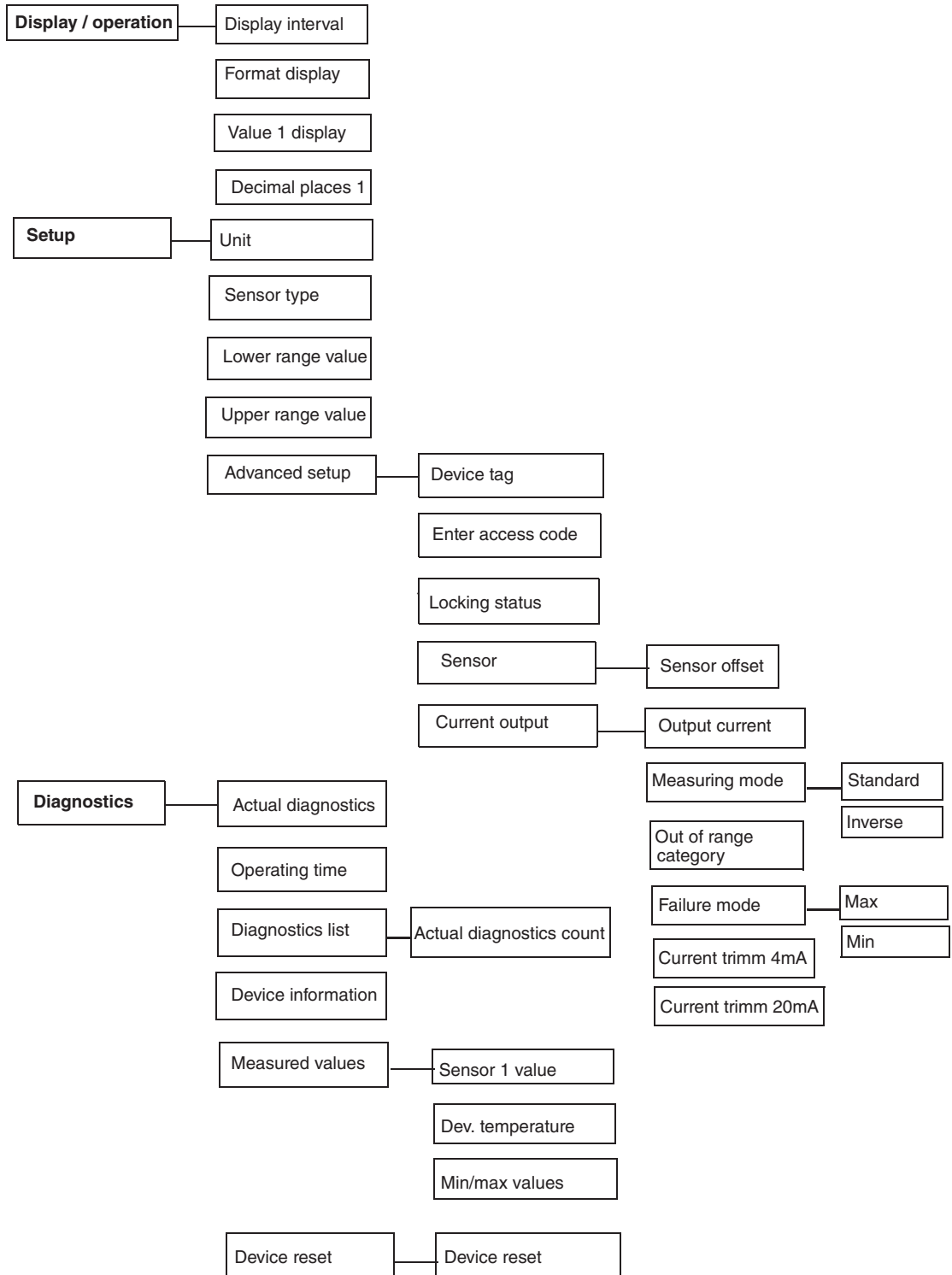

Table 5. Display Information

Display	Information
1	Tag
2	Communication icon
3	Engineering unit
4	Measured value
5	Channel of measured value (S1, S2, DT, PV, I, %)
6	Configuration locked
7	Status (fault communication) <ul style="list-style-type: none"> <li>▶ S = Out of specification – Device is operating outside of its technical specifications</li> <li>▶ C = Service mode – Device is in service mode (i.e. device in simulation)</li> <li>▶ M = Maintenance required – Measurement is valid but a monitored diagnostic parameter indicates that maintenance is needed</li> <li>▶ F = Fault – Measurement is not valid. The “F” symbol is appended by a diagnostic code (See Chapter 4, “Maintenance”.)</li> </ul>

# Online Menu

## Operating menu for operators and maintenance technicians



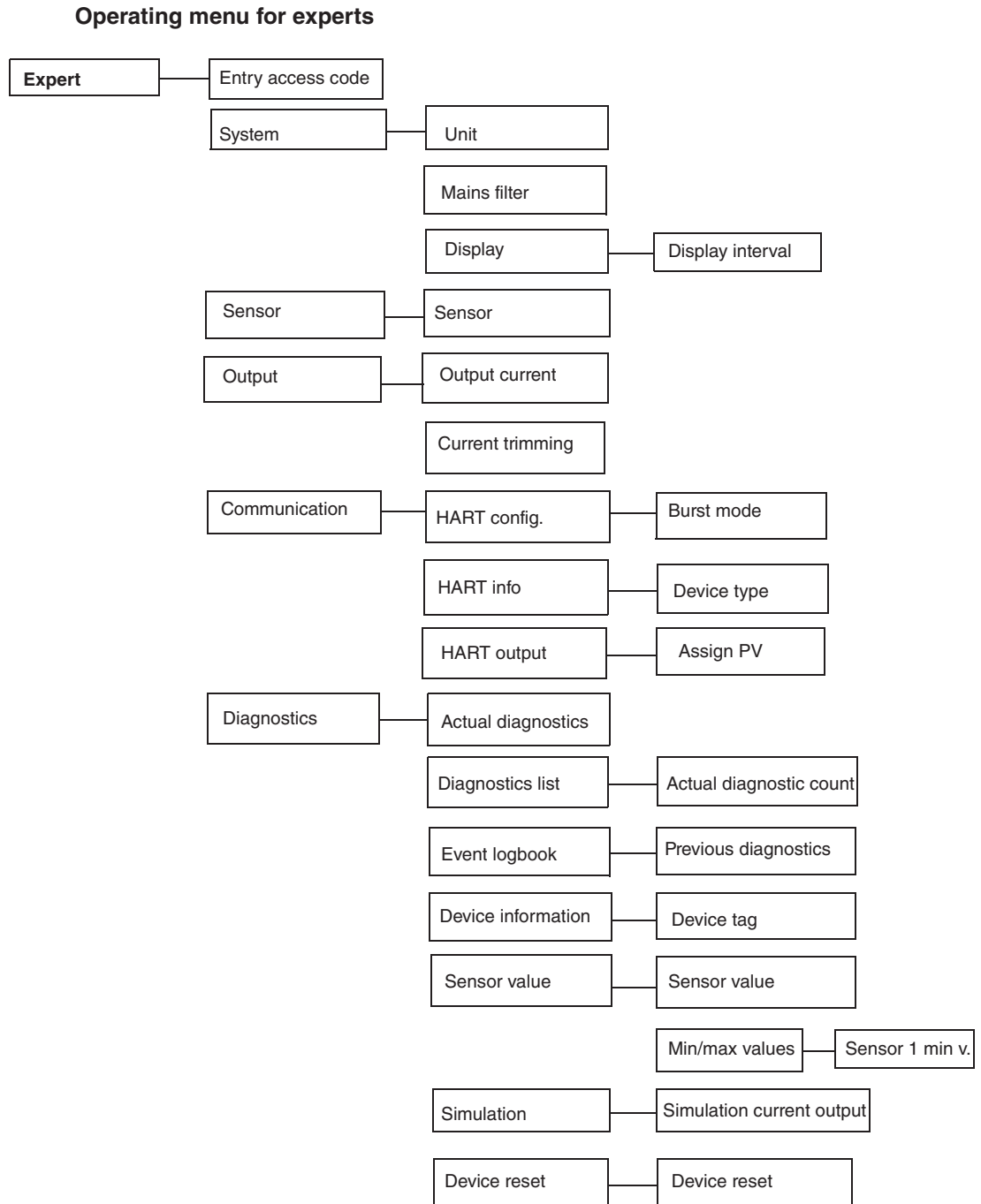

# 4. Maintenance

The RTT80-T Transmitter basic unit has no moving parts and is a completely sealed unit. If there is a problem, refer to the following troubleshooting section for possible corrective actions.

---

**! CAUTION**

The basic transmitter is completely sealed unit and cannot be repaired. Any attempt to open the basic transmitter voids the warranty.

---



---

**! DANGER**

For nonintrinsically safe installations, to prevent a potential explosion in a Division 1 hazardous area, deenergize the transmitter before you remove the threaded housing cover. Failure to comply with this warning could result in an explosion resulting in severe injury or death.

---

## Troubleshooting

*Table 6. Recommended Troubleshooting Steps Before Replacing Module*

Indication	Action
Erratic Measurement	Check Wiring Connections – Look for any loose connections or corroded terminals
	Check Sensor – See instrument diagnostics (a) or use a multimeter to measure sensor
	Check Grounding – Look for ground loops or noise on the bus with a digital scope
	Check Power Supply – Check for adequate power levels
	Check that the sensor type configured matches the sensor type being used
Inaccurate Measurement	Check Sensor - See instrument diagnostics <sup>(a)</sup> or use a multimeter to measure sensor
	Check Grounding - Look for ground loops or noise on the bus with a digital scope
	Check Sensor Calibration – User multimeter to approximate sensor input or use a temperature bath for more accuracy
	Check Transmitter Calibration – Use a decade box or millivolt input to simulate sensor output
	Check Instrument Configuration – Check configured ranges and check for any unintentional rescaling
Device will not Communicate	Check Instrument Configuration – Check for correct addressing, correct tagging, and so forth. (digital communications)
	Check Power Supply – Check for adequate power levels. Check signal strength at I/O card
	Check Grounding – Look for ground loops or noise on the bus with a digital scope
	Check that there is a minimum of 250 Ω loop resistance between the power supply and the HART Communicator

**Table 6. Recommended Troubleshooting Steps Before Replacing Module (Continued)**

Indication	Action
Transmitter is in Failsafe	Check Sensor – See instrument diagnostics <sup>(a)</sup> or use a multimeter to measure sensor
	Check Wiring Connections – Look for any loose connections or corroded terminals
	Check Configuration (Ranges, sensor type, and so forth.)
	Check Transmitter Calibration – Use a decade box or millivolt input to simulate sensor output

a. Using a HART Communicator or PC-Based Configurator.

**Figure 19. Troubleshooting Diagram**

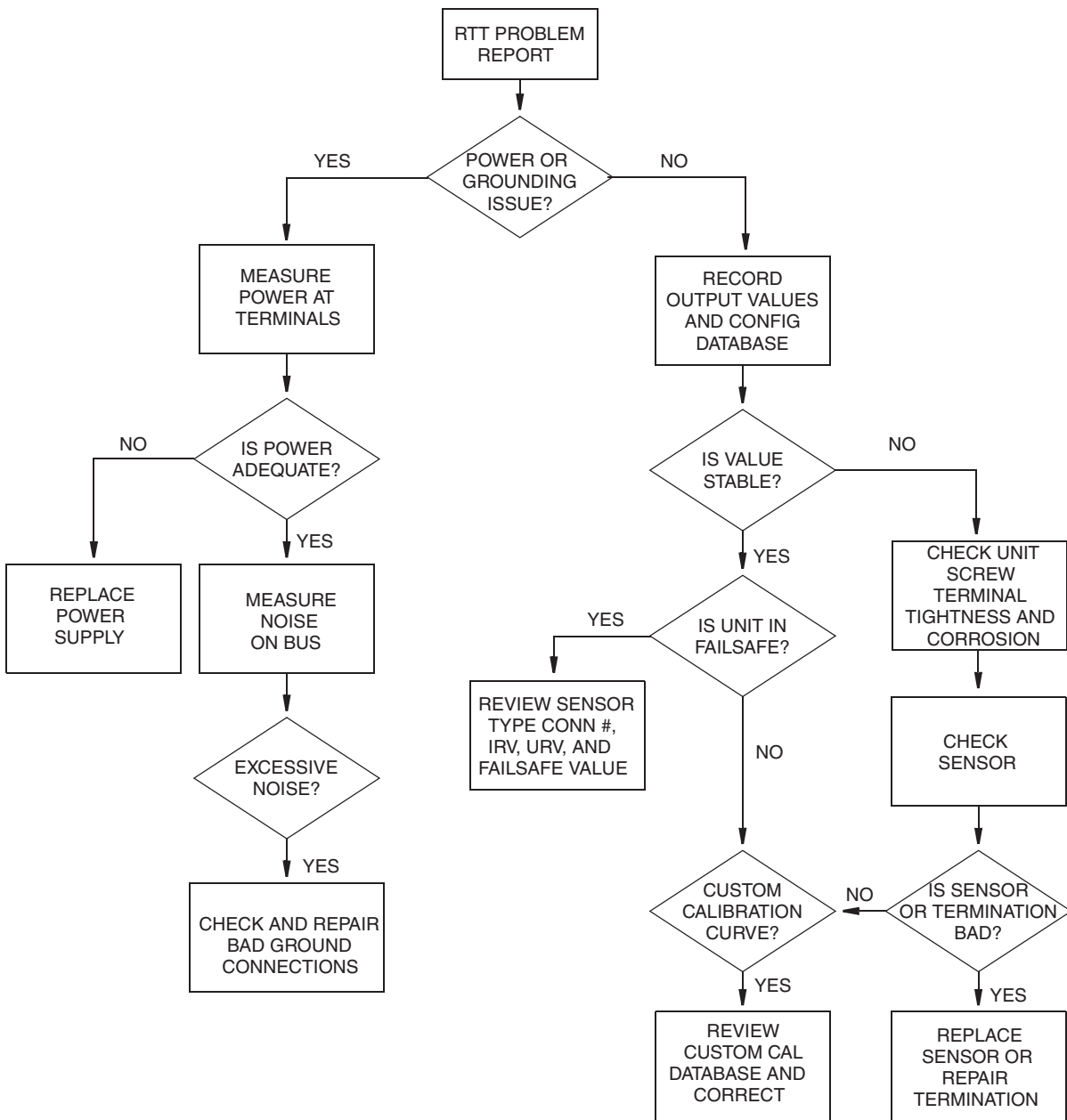

## Replacing the Transmitter

### DIN Rail Mounted Units

1. Turn off the transmitter power source.
2. If the optional display is present, unplug the display from the transmitter by gently pulling it away.
3. Disconnect all wires from the transmitter noting which wire went to each terminal.
4. Remove the transmitter by removing the screw and the bushing that secures it to the DIN Clip.
5. Install the new transmitter by reversing Steps 1 to 4 above and torque the screw to  $8 \pm 1$  in-lb.

### Universal Housing Mounted Units

1. Turn off the transmitter power source.
2. Remove the housing cover (if applicable).
3. If the optional display is present, unplug the display from the transmitter by gently pulling it away.
4. Disconnect all wires from the transmitter noting which wire went to each terminal.

*Figure 20. Input Connections*

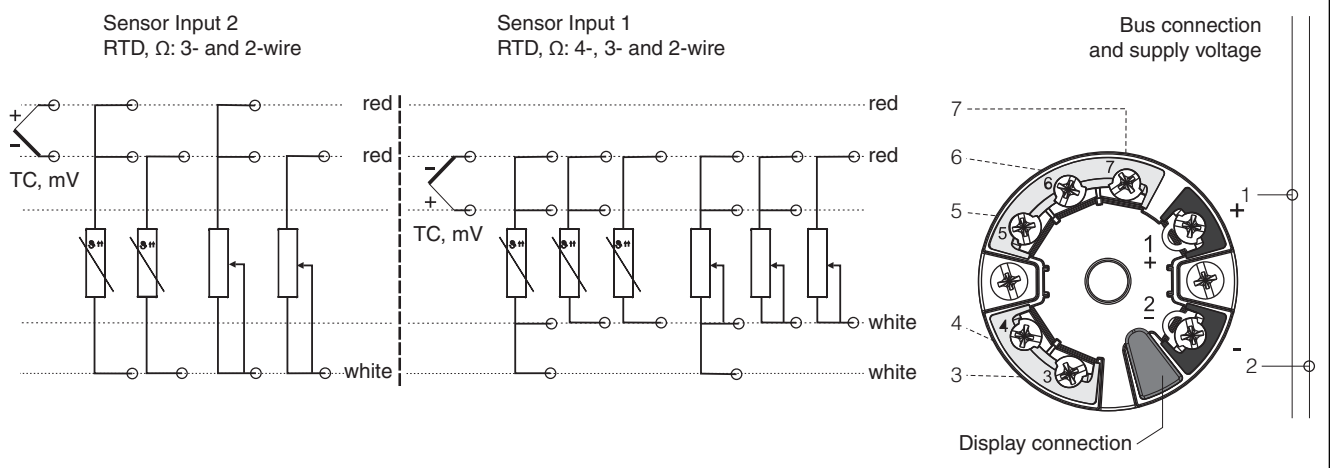

5. Remove the transmitter by removing the two screws that secure it to the housing.
6. Install the new transmitter by reversing Steps 1 to 5 above and torque the screws to  $8 \pm 1$  in-lb.

---

**NOTE**

It is recommended that the screws be replaced when the transmitter is replaced.

---

**! CAUTION**

When replacing housing cover, tighten the cover so that the flange of the cover comes in contact with the flange on the housing.

## Dual Compartment Housing Mounted Units

1. Turn off the transmitter power source.
2. Remove the housing cover.
3. If the optional display is present, unplug the display from the transmitter by gently pulling it away.
4. Disconnect all the color-coded wires from the transmitter, and note which wire went to each terminal:

Terminal 1	Red
Terminal 2	Brown
Terminal 3	Orange
Terminal 4	Yellow
Terminal 5	Green
Terminal 6	Blue
Terminal 7	Purple

5. Remove the transmitter by loosening the two screws that secure it to the mounting plate.
6. Install the new transmitter by reversing Steps 1 to 5 above and torquing the screws to 7 ±1 in-lb.

**NOTE**

It is recommended that the screws be replaced when the transmitter is replaced.

**! CAUTION**

When replacing housing covers, tighten each cover so that the flange of the cover comes in contact with the flange of the housing.

## Diagnostics

Diagnostic error messages may be manifested either by the optional display or by a means of device interface, such as DD or DTM.

Diagnostic errors are communicated in four levels as listed below:

*Table 7. Diagnostic Errors*

Diagnostic Symbol	Category	Description
F	Device Failure	The measured value is no longer valid.
M	Maintenance Required	The measurement is valid but device maintenance should be scheduled soon.
C	Service Mode	The device is operating correctly but it has been taken out of service and the measurement may not be valid.



*Table 7. Diagnostic Errors*

Diagnostic Symbol	Category	Description
S	Out of Specification	The device is operating outside of prescribed specification limits. Measurement may be valid.

Some diagnostic events may be configured to one or more of the above categories.

Diagnostic severity can be categorized as described below:

*Table 8. Diagnostic Severity*

Severity	Behavior
Alarm	The measurement is interrupted. The device will take on the failure condition that has been prescribed (i.e. failsafe). Diagnostic messages will reference the Device Failure (F) category.
Warning	The device continues to communicate a measurement. Diagnostic message will reference the Maintenance Required (M), Service (C) or Out of Specification (S) category.

Some diagnostic events may be user-configured for severity.

## Display

The optional display will annunciate a diagnostic event.

In the event of a warning, the display will alternate between the diagnostic code number preceded by the category (M, C or S) symbol and the configured measurement. For example, a corroded sensor that is configured for a Maintenance category will display “M042” on black background alternating with the measurement in a normal format (black characters on green background).

In the event of an alarm, the display will alternate between the diagnostic code number preceded by the “F” symbol and “----” to indicate no measurement. For example, a broken sensor with no redundancy will display “F041” on black alternating with “----” in black characters on green background.

See Table 9 for diagnostic codes and descriptions.

The optional display will show the current diagnostic with the highest priority. If more than one diagnostic is active, all current diagnostic messages can be read using a Device Interface.

## Device Interface

Diagnostic messages can be read via a device interface, such as an SDC 625 host, hand-held configurator or Field Device Tool frame application. More detailed information is available with these interfaces.

See the “Configuration” on page 31 for details of configuring diagnostics. See MI 020-520 for RTT80 diagnostics DTM screens.

*Table 9. Diagnostic Codes*

Diagnostic Code	Displayed Text	Description / Action	Category	Severity
Input Diagnostics				
001	Device Error	Device has failed. Replace the module.	F	Alarm

Table 9. Diagnostic Codes (Continued)

Diagnostic Code	Displayed Text	Description / Action	Category	Severity
006	Sensor Redundancy Active	Backup measurement is active. Check primary sensor.	M	Warning
041	Sensor Broken	Sensor input is bad. Check sensor and replace if necessary. Check sensor configuration.	F	Alarm
042	Sensor Corroded	Input indicates potential sensor corrosion. Check sensor connections and replace sensor if necessary.	M or F	Alarm or Warning
043	Short Circuit	Input indicates potential sensor shorting. Check sensor connections and replace sensor if necessary.	F	Alarm
044	Sensor Drift	Sensor input is drifting between sensors. Check sensor connections. Check process temperature.	M, F or S	Alarm or Warning
045	Operating Range	Measurement is outside of operating range. Check ambient temperature. Check external reference measurement.	F	Alarm
101	Sensor Value Too Low	Sensor input is below expected level. Check sensor type. Check process temperature. Replace sensor if necessary.	F	Alarm
102	Sensor Value Too High	Sensor input is above expected level. Check sensor type. Check process temperature. Replace sensor if necessary.	F	Alarm
104	Backup Active	Sensor 2 has become primary measurement. Check Sensor 1.	M	Warning
105	Calibration Interval	Calibration countdown timer has expired. Perform calibration or deactivate counter.	M or F	Alarm or Warning
106	Backup Not Available	Backup is configured but Sensor 2 input does not appear to be valid. Check Sensor 2 connections or replace Sensor 2 if necessary. If backup is not intended, reconfigure Current Output.	M	Warning
Electronics Diagnostics				
201	Electronics Error.	Device has failed. Replace the module.	F	Alarm
221	Electronics Reference	Internal electrical references have failed. Replace the module	F	Alarm
241	Electronics Software.	Internal software algorithms have failed. Restart or reset the device or replace the module.	F	Alarm
261	Electronics Module	Display module has failed. Replace the display.	F	Alarm
262	Module Connection	Check electrical connection between transmitter module and display module. Replace display if necessary.	M	Warning
283	Memory Content	emory is corrupted. Replace the module.	F	Alarm
301	Supply Voltage	Voltage is outside operating limits. Check bus/power connections. Check power supply.	F	Alarm
Configuration Diagnostics				
401	Factory Reset	Device is resetting. Please wait until initialization is complete.	C	Warning
402	Configuration Initialization	Configuration is being initialized in the transmitter. Please wait until initialization is complete	C	Warning

*Table 9. Diagnostic Codes (Continued)*

<b>Diagnostic Code</b>	<b>Displayed Text</b>	<b>Description / Action</b>	<b>Category</b>	<b>Severity</b>
411	Upload/Download	Configuration data is be written to the transmitter. Please wait until initialization is complete.	C	Warning
431	Factory Calibration	Device has lost its factory calibration data. Replace electronics module.	F	Alarm
435	Linearization	Problem with sensor linearization data. Check configuration of sensor parameters. Check configuration of sensor linearization. Replace electronics module.	F	Alarm
437	Configuration	Check sensor configuration. Check transmitter settings. Replace electronics module.	F	Alarm
451	Data Handling	Data transfer in progress. Please wait.	C	Warning
483	Simulation Input	Raw sensor input is being simulated. End simulation.	C	Warning
484	Simulation Measured Value	Conditioned digital measurement is being simulated. End simulation.	C	Warning
485	Simulation Current Output	mA output is being simulated. End simulation.	C	Warning
Process Diagnostics				
803	Current Loop	Current loop detected. Check wiring or replace electronics module.	F	Alarm
842	Process Limit	Configured limit has been exceeded. Check the adjusted range of the current output.	M, F or S	Alarm or Warning
925	Device Temperature	Operating temperature range has been exceeded. Check ambient temperature.	S or F	Warning

**ISSUE DATES**

APR 2012                      NOV 2014  
MAY 2013  
OCT 2013  
FEB 2014

Vertical lines to the right of text or illustrations indicate areas changed at last issue date.



Invensys Systems, Inc.  
10900 Equity Drive  
Houston, TX 77041  
United States of America  
<http://www.invensys.com>

Global Customer Support  
Inside U.S.: 1-866-746-6477  
Outside U.S.: 1-508-549-2424  
Website: <http://support.ips.invensys.com>

Copyright 2012-2014 Invensys Systems, Inc.  
All rights reserved.

Invensys, Foxboro, and I/A Series are trademarks of  
Invensys Limited, its subsidiaries, and affiliates. All other  
trademarks are the property of their respective owners.

Invensys is now part of Schneider Electric.