

**MODEL RTT30 Intelligent Temperature Transmitter
with FOUNDATION Fieldbus Communication Protocol**



The Foxboro® brand Model RTT30 is a microprocessor based, full featured, high performance, 2-wire temperature transmitter. It receives input signals from thermocouples, RTDs, resistance (ohm), or voltage (mV) sources. It is offered with FOUNDATION Fieldbus Communication Protocol.

FEATURES

- ▶ FOUNDATION Fieldbus H1, 31.25 kBits/s.
- ▶ Interoperability tested-FOUNDATION registered.
- ▶ Field-proven microprocessor-based transmitter ensures accurate measurement and performance.
- ▶ Dual, independent sensor input capability for difference/average measurement, or sensor backup.
- ▶ Backlit indicator with measured value, bar graph, and fault indication displays, easy to read.
- ▶ Drift alarm, sensor backup, and sensor corrosion detection enhances reliable operation.
- ▶ Sensor input-to-output galvanic isolation of 2 kV.
- ▶ Link Master capable.
- ▶ Ability to display parameters of up to 4 other devices on the same segment.
- ▶ Compact, dual compartment enclosure with fully potted electronics. Enclosure meets IP67 and NEMA 4X ratings.
- ▶ Aluminum or 316L ss housing offered to meet user's specific requirements.
- ▶ FISCO/FNICO compliant per IEC 60079-27.
- ▶ Stainless steel mounting bracket sets offered for surface and nominal DN 50 or 2-in pipe mounting.
- ▶ Features multiple function blocks to support control in the field.
- ▶ Standard 2-year warranty.

GENERAL DESCRIPTION

The Model RTT30 Intelligent Temperature transmitter is a full-featured, 2-wire digital output transmitter with FOUNDATION Fieldbus communication protocol. Input signals are received from RTDs and thermocouples, and also from resistance and millivolt sources. There can be two measuring inputs in 2-, 3-, or 4-wire connections (i.e., two 3-wire RTDs, or one 4-wire RTD and one TC), and the transmitter is mounted in a remote location. A backlit LCD Indicator can be provided that shows the current value digitally and as a bar graph with an indicator for alarms. See Figure 1 for typical installations, and also see the Backlit LCD Indicator paragraph and Figure 3 further in this document.

FOUNDATION FIELDBUS INTERFACE

Complies with H1, IEC 61158-2. Current consumption is ≤ 12 mA. Data transmission rate is 31.25 kBits/s, Manchester II signal encoding. Function blocks featured are: Sensor Transducer blocks (2), an Advanced Diagnostics Transducer block, Analog Input blocks (3), a PID (Proportional, Integral, Derivative) block, and an Input Selector block. Supports Link Master functionality.

2-CHANNEL FUNCTIONS

These functions increase the reliability and availability of the process values, as follows:

- ▶ Hot Sensor Backup - Transmitter switches to redundant sensor if primary sensor fails.
- ▶ Temperature dependent switching between sensors, which have advantages in different ranges.
- ▶ Drift alert or alarm if sensor 1 and 2 deviate from one another.

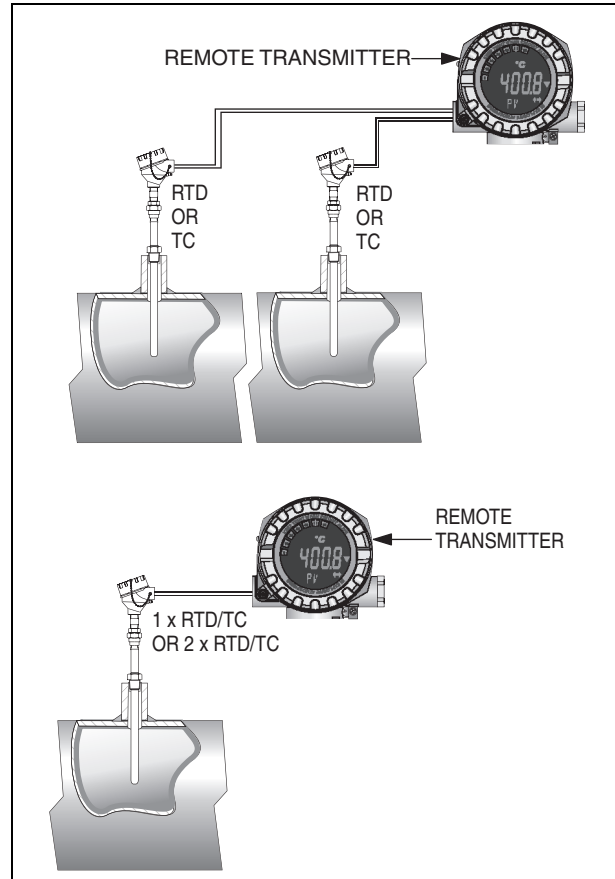

Figure 1. Typical Installations

INPUT TYPES

This RTT30 Transmitter can be used with a wide variety of temperature sensors, including 2-, 3-, and 4-wire RTDs, most popular thermocouples, and other resistance and millivolt input devices. The following is a general list of transmitter input types:

- ▶ Platinum RTDs, 2-, 3-, and 4-wire
- ▶ Copper RTDs
- ▶ Nickel RTDs
- ▶ Thermocouples
- ▶ Millivolt Sources
- ▶ Ohm Sources

EFFICIENT AND DURABLE

Industrial-grade integrated circuits and sealed electronics combine to make this microprocessor-based transmitter an efficient and durable device.

HOUSING CONFIGURATIONS

The enclosure can be provided with an aluminum housing or with a stainless steel housing, each with or without an LCD indicator. Selections are offered for installations that require flameproof, explosionproof, intrinsically safe, and nonincendive certifications. Brackets are provided for remote mounting the enclosure. See paragraph below.

MOUNTING BRACKET CONFIGURATIONS

The RTT30 can be supplied with either of two different mounting bracket configurations. A U-shaped bracket can be provided when only pipe mounting the enclosure to a nominal DN 50 or 2-in pipe is required; and an L-shaped bracket can be provided for use with either surface or pipe mounting the enclosure. The bracket material is stainless steel. See Figure 2.

CORROSION DETECTION

Corrosion of the sensor connections can lead to corruption of the measured value. The transmitter is able to detect corrosion on thermocouples and RTDs with a 4-wire connection before measured value corruption occurs. The transmitter avoids false measurement readings and is also able to indicate a warning or error on the display when wire resistance exceeds reasonable values.

USABLE IN HAZARDOUS AREA LOCATIONS

The Model RTT30 Temperature Transmitter meets the requirements of many certifying agencies for use in hazardous area locations. Refer to the ELECTRICAL SAFETY SPECIFICATIONS section for further details.

EMI AND NAMUR COMPATIBILITY

Complies with the Electromagnetic Compatibility requirements of European EMC Directive 2004/108/EC, and also NAMUR Standard NE 21. See PERFORMANCE SPECIFICATIONS section.

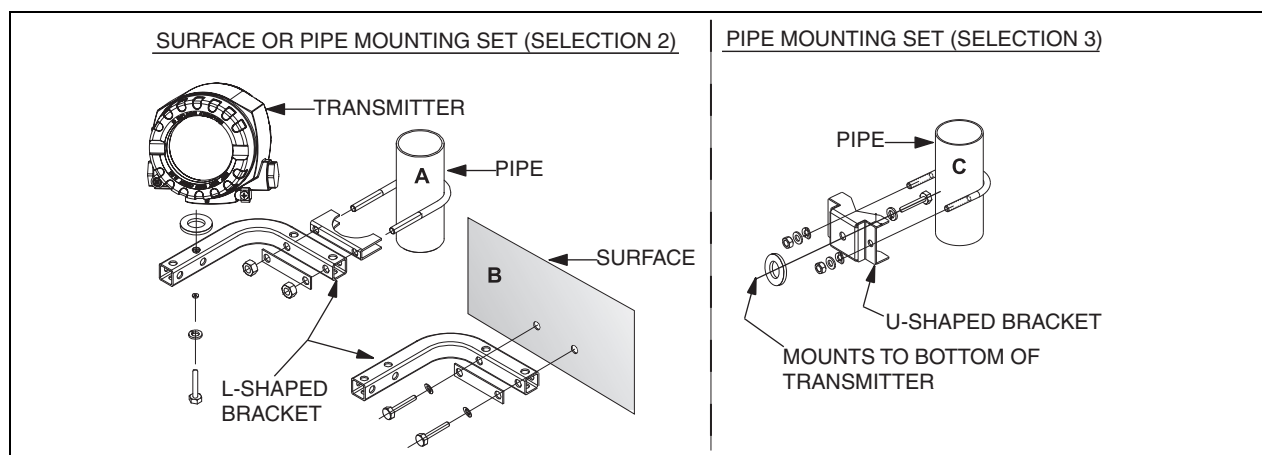

Figure 2. Transmitter Pipe or Surface Mounting Sets

BACKLIT LCD INDICATOR

The indicator assembly with a backlit display can be plugged into the electronics compartment at 90° intervals. This allows flexibility in indicator orientation depending on transmitter installation. The engineering units display is in either K, °F, °C, or %. The measured value display character height is 20.5 mm (0.81 in). The display elements are shown in Figure 3 and described in Table 1.

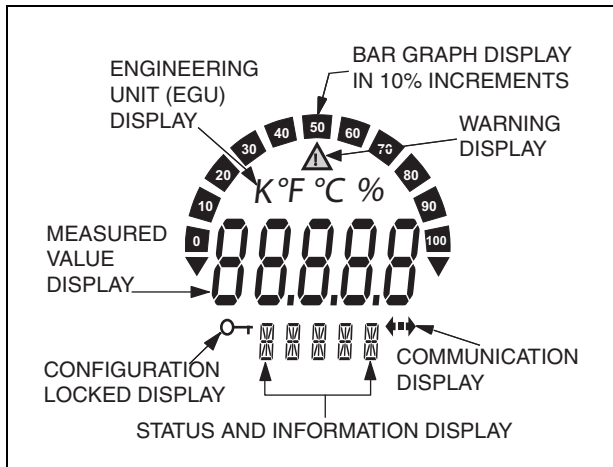

Figure 3. Indicator Display Elements

Table 1. Indicator Display Elements

Display Elements	Description (a)
Bar Graph Display	In 10% increments with overrange and underange marks.
WARNING Display	This is displayed whenever an error or WARNING is given.
Engineering Unit Display (EGU): K, °F, °C, or %	Measured value displayed in selected Engineering Units.
Measured Value Display: 20.5 mm (0.81 in) Character Height.	Displays measured value. If a WARNING is present, the display alternates between measured value and WARNING Code. In the event of an error, the Error Code is displayed rather than the measured value.
Status and Information Display	Indicates which value currently appears on the display. In the event of an error or warning, relevant error/warning information is displayed.
Communication Display	This communication icon appears when bus communication is active.
Configuration Locked Display	This icon is displayed when the configuration is locked via a DIP switch.

(a) Refer to applicable Operation Manual for more specific details.

OPERATING, STORAGE, AND TRANSPORTATION CONDITIONS

Influence	Reference Operating Conditions	Operative Limits	Storage and Transportation Limits
Ambient Temperature ▶ Without Integral Indicator ▶ With Integral Indicator	▶ 25 ± 5°C (77 ± 9°F) ▶ 25 ± 5°C (77 ± 9°F)	▶ -40 and + 85°C (a) (-40 and +185°F) (a) ▶ -20 and + 70°C (a)(b) (-4 to +158°F) (a)(b)	▶ -40 and +100°C (-40 and +212°F) ▶ -40 and +85°C (-40 and +185°F)
Relative Humidity	50 ±10%	0 and 100% (c)	0 and 100% (c)
Supply Voltage (d)	▶ 24 ± 0.5 V dc	▶ 9 and 32 V dc (e)	N/A
Altitude	Sea Level	Up to 2000 m (6560 ft)	N/A
Shock and Vibration Resistance	Negligible	0 and 30 m/s ² (0 and 3 "g") from 2 to 150 Hz (f)	107 mm (42 in) Drop in Shipping Container

- (a) Refer to Electrical Safety Specifications section for a restriction in ambient temperature with certain agency approvals and certifications.
- (b) The LCD Indicator display may react slowly at temperatures below -20°C (below -4°F); Readability of the display cannot be guaranteed at temperatures below -30°C (below -22°F).
- (c) Condensation permitted.
- (d) Supply voltage values listed are with reverse polarity protection. Maximum voltage is 35 V dc.
- (e) Maximum voltage = 35 V dc.
- (f) Per IEC 60068-2-6.

PERFORMANCE SPECIFICATIONS

Under Reference Operating Conditions unless Otherwise Specified

Measurement Accuracy

Sensor Type	Sensor Designation	Measurement Accuracy
RTD	Cu100, Ni100, Ni120, Pt100	0.1°C (0.18°F)
	Cu50, Ni1000, Pt50, Pt1000	0.2°C (0.36°F)
	Pt500	0.3°C (0.54°F)
	Cu10, Pt200	1.0°C (1.8°F)
Thermocouple	Types E, J, K, L, T, U	0.25°C (0.45°F) (a)
	Types N, C, D	0.5°C (0.9°F) (a)
	Types B, R, S	1.0°C (1.8°F) (a)
Input Source	Measurement Range	Measurement Accuracy
Voltage Transmitter	-20 to +100 mV	±10 μV
Resistance Transmitter	10 to 400 Ω	±0.04 Ω
	10 to 2000 Ω	±0.08 Ω

- (a) Thermocouple Accuracies listed are typical values.

PERFORMANCE SPECIFICATIONS (CONT.)

Response Time

1 second per channel

Repeatability

± 0.0015% of the input range of the sensors. See Table 2 for the sensor input range with each sensor type.

Long Term Stability

≤ 0.1°C (≤ 0.18°F) per year; or
≤ 0.05% per year (relates to set span).

NOTE

Stability is the larger of the temperature or percent (%) values specified above.

Ambient Temperature Effect (Temperature Drift)

Ambient temperature effect values listed below are for a 1°C (1.8°F) change in ambient temperature within operative limits.

- ▶ 10 to 400 Ω Input: Typical, 0.001% of measured value, with a minimum value of 1 mΩ
- ▶ 10 to 2000 Ω Input: Typical, 0.001% of measured value, with a minimum value of 10 mΩ
- ▶ -20 to +100 mV Input: Typical, 0.001% of measured value, with a minimum value of 0.2 μV.
- ▶ -5 to +30 mV Input: Typical, 0.001% of measured value, with a minimum value of 10 μV.

Sensitivity

See Table 3 for typical sensitivity of RTDs, and see Table 4 for typical sensitivity of thermocouples.

Table 2. Sensor Input Range

Sensor Type	Input Range
RTD: Cu10, Cu50, Cu100, Ni100, Ni120, Pt50, Pt100	10 to 400 Ω
RTD: Ni1000, Pt200, Pt500, Pt1000	10 to 2000 Ω
Thermocouple: Types B, R, S, T	-5 to +30 mV
Thermocouple: Types C, D, E, J, K, L, N, U	-20 to +100 mV

Table 3. Typical Sensitivity of RTDs

RTD Type	Typical Sensitivity (a)
Pt	(0.00385) (Rnominal/K)
Cu	(0.0043) (Rnominal/K)
Ni	(0.00617) (Rnominal/K)

(a) For example, for Pt100 RTD;
Typical Sensitivity = (0.00385)(100 Ω/K) = 0.385 Ω/K.

Table 4. Typical Sensitivity of Thermocouples

Typical Sensitivity			
TC Type	Sensitivity	TC Type	Sensitivity
B	10 μV/K	K	40 μV/K
R	12 μV/K	T	50 μV/K
S	12 μV/K	J	55 μV/K
C	20 μV/K	L	55 μV/K
D	20 μV/K	U	60 μV/K
N	35 μV/K	E	75 μV/K

Supply Voltage Effect

None

PERFORMANCE SPECIFICATIONS (CONT.)

Compliance with European Union Directives

The transmitter, when installed in accordance with the applicable installation instruction (MI), complies with the EMC requirements of European EMC Directive 2004/108/EC by conforming to the following EN and IEC Standards: EN 61326-1, IEC 61000-4 (as listed below), and NAMUR Standard NE 21 (as listed below).

- ▶ Electrostatic Discharge per IEC 61000-4-2:
6 kV Cont., 8 kV air.
- ▶ Radiated RF Immunity per IEC 61000-4-3:
0.08 to 4.0 GHz; 10 V/m
- ▶ High Frequency Transient per IEC 61000-4-4:
1 kV
- ▶ Switching and Indirect Lightning Transient (Surge) per IEC 61000-4-5:
1 kV asymmetrical
- ▶ Conducted RF Immunity per IEC 61000-4-6:
0.01 to 80 MHz; 10 V
- ▶ Interference Immunity requirements per NAMUR NE 21.

Measuring Category

Measuring Category II per IEC 61010-1. The measuring category is provided for measurements at circuits with a direct electrical connection to the low voltage supply.

Installation Category

Installation Category 1 to IEC 61010.

Pollution Degree

Pollution degree 2 per IEC 61010.

Climate Class

Climate Class per IEC 60654-1, Class C.

FUNCTIONAL SPECIFICATIONS

Span and Range Limits

RTD INPUT

See Table 3

THERMOCOUPLE INPUT

See Table 4

VOLTAGE INPUT

See Table 5

RESISTANCE INPUT

See Table 5

Table 5. RTD Input - Span and Range Limits

RTD Designation and Description	Measurement Range Limits	Minimum Span
Cu10 alpha = 0.004274; To Edison Copper Winding No. 15	-100 and +260°C (-148 and +500°F)	10°C (18°F)
Cu50 alpha = 0.004278; To GOST	-200 and +200°C (-328 and +392°F)	10°C (18°F)
Cu100 alpha = 0.004278; To GOST	-200 and +200°C (-328 and +392°F)	10°C (18°F)
Ni100 alpha = 0.006180; To DIN 43760	-60 and +250°C (-76 and +482°F)	10°C (18°F)
Ni120 alpha = 0.006720; To Edison Curve	-70 and +270°C (-94 and +518°F)	10°C (18°F)
Ni1000 alpha = 0.006180; To DIN 43760	-60 and +150°C (-76 and +302°F)	10°C (18°F)
Pt50 alpha = 0.003911; To GOST	-200 and +1100°C (-328 and +2012°F)	10°C (18°F)
Pt100 alpha = 0.003916; To JIS C1604-81	-200 and +649°C (-328 and +1200°F)	10°C (18°F)
Pt100 alpha = 0.003911; To GOST	-200 and +850°C (-328 and +1562°F)	10°C (18°F)
Pt100 alpha = 0.00385; To IEC 60751	-200 and +850°C (-328 and +1562°F)	10°C (18°F)
Pt200 alpha = 0.00385; To IEC 60751	-200 and +850°C (-328 and +1562°F)	10°C (18°F)
Pt500 alpha = 0.00385; To IEC 60751	-200 and +250°C (-328 and 482°F)	10°C (18°F)
Pt1000 alpha = 0.00385; To IEC 60751	-200 and +250°C (-328 and +482°F)	10°C (18°F)

FUNCTIONAL SPECIFICATIONS (CONT.)

Table 6. Thermocouple Inputs - Span and Range Limits

Thermocouple Designation and Description	Measurement Range Limits	Minimum Span
Type T Cu-CuNi; IEC 584-1	-270 and +400°C (-454 and +752°F)	50°C (90°F)
Type E NiCr-CuNi; IEC 584-1	-270 and +1000°C (-454 and +1832°F)	50°C (90°F)
Type N NiCrSi-NiSi; IEC 584-1	-270 and +1300°C (-454 and 2372°F)	50°C (90°F)
Type K NiCr-Ni; IEC 584-1	-270 and +1372°C (-454 and +2501°F)	50°C (90°F)
Type J Fe-CuNi; IEC 584-1	-210 and +1200°C (-346 and +2192°F)	50°C (90°F)
Type U Cu-CuNi; IEC 43710	-200 and +600°C (-328 and +1112°F)	50°C (90°F)
Type L Fe-CuNi; DIN 43710	-200 and +900°C (-328 and +1652°F)	50°C (90°F)
Type R PtRh13-Pt; IEC 584-1	-50 and +1768°C (-58 and +3214°F)	500°C (900°F)
Type S PtRh10-Pt; IEC 584-1	-50 and +1768°C (-58 and +3214°F)	500°C (900°F)
Type B (a)(b) PtRh30-PtRh6; IEC 584-1	40 and 1820°C (104 and 3308°F)	500°C (900°F)
Type C W5Re-W26Re; ASTM E988	0 and 2315°C (32 and 4199°F)	500°C (900°F)
Type D W3Re-W25Re; ASTM E988	0 and 2315°C (32 and 4199°F)	500°C (900°F)

(a) The measuring error (see Table 1) will increase for temperatures lower than 300°C (572°F).

(b) When operation conditions are based on a large temperature range, the RTT30 offers the ability to split the range. For example, a Type S or R thermocouple can be used for the low range, while a Type B can be used for the upper range.

Table 7. Voltage and Resistance Inputs - Span and Range Limits

Input Source	Measurement Range Limits	Minimum Span
Voltage Transmitter	-10 and +100 mA	5 mV
Resistance Transmitter	10 and 400 Ω	10 Ω
Resistance Transmitter	10 and 2000 Ω	100 Ω

Output Signal

- ▶ Digital Output.
- ▶ Data Transmission Rate: 31.25 Kbit/sec
- ▶ Signal Encoding Manchester II
- ▶ Galvanic Isolation: 2 kV ac (Input/Output)

Current Consumption

- ▶ Basic Current: ≤12 mA

Filter

1st order digital filter: 0 to 60 s

FUNCTIONAL SPECIFICATIONS (CONT.)

Warm-Up Time

5 s during switch-on operation

Block Execution

- ▶ Analog Input: 35 ms
- ▶ PID: 50 ms
- ▶ Input Selector: 30 ms.

Write Protect Function

This function locks out all configurators from making transmitter configuration changes. This makes transmitter suitable for Safety Shutdown System Applications that require this feature. This feature is activated by a DIP switch in the electronics compartment.

PHYSICAL SPECIFICATIONS

Enclosure Material

- ▶ Die-cast aluminum housing (<0.1% copper content) with a powder coating on a polyester base.
- ▶ 316L stainless steel housing.

Enclosure Construction

A dual compartment enclosure, one for the electronics and one for the cable entry and electrical connections. The compartment covers are threaded and include O-rings to seal the enclosure. Cover clamp kits are provided to prevent cover rotation.

Enclosure Mounting

Surface or pipe mounting brackets can be provided with the enclosure. An L-shaped 304 ss bracket is offered for either surface or pipe mounting the transmitter, and a U-shaped 316L ss bracket is offered for pipe mounting only. Either bracket is for attaching to a nominal DN 50 or 2-in pipe using a U-bolt. See DIMENSIONS-NOMINAL section.

Electronics Assembly

Fully potted electronics provide environmental protection.

LCD Indicator

The indicator is located in the electronics compartment, and can be plugged in at 90° intervals.

This allows flexibility in display orientation, depending on the transmitter's installation location.

Electrical Connections

Two 1/2 NPT or M20 threaded connections are provided on the housing for cable or wire entry. Also an external grounding connection is located at the lower surface of the housing.

Sensor Installation

The thermocouple or RTD is typically installed in a remote location.

Environmental Protection

The enclosure has the dusttight and weatherproof rating of IP67 as defined by IEC 60529, and provides the environmental and corrosion resistant protection rating of NEMA 4X.

Approximate Weight

ALUMINUM HOUSING WITH INDICATOR

1.4 kg (3.1 lb)

316L ss HOUSING WITH INDICATOR

4.2 kg (9.3 lb)

Dimensions

Refer to DIMENSIONS-NOMINAL section.

ELECTRICAL SAFETY SPECIFICATIONS

Testing Laboratory, Types of Protection, and Area Classification	Application Conditions	Elec. Safety Design Code
None - Instrument in a nonhazardous area location.		A
FM intrinsically safe and nonincendive; Class I, Divisions 1 and 2, Groups A, B, C, and D. Also Class I, Zone 0 AEx ia IIC, and Class 1, Zone 2 AEx nA.	Temperature Class T4; Ta = -40 to +85°C	C
FM explosionproof, nonincendive, and dust-ignitionproof; Class I, II, III, Divisions 1 and 2, Groups A to G. Also Class I, Zone 1 AEx d IIC, and Class I, Zone 2 AEx nA.	Temperature Class T6; Ta = -40 to +55°C Temperature Class T5; Ta = -40 to +70°C Temperature Class T4; Ta = -40 to +85°C	F
FM explosionproof, dust-ignitionproof, intrinsically safe, and nonincendive; Class I, II, III, Divisions 1 and 2, Groups A to G. Also Class I, Zone 1 AEx d IIC, Class I, Zone 0 AEx ia IIC, and Class I, Zone 2 AEx nA.	Temperature Class T6; Ta = -40 to +55°C Temperature Class T5; Ta = -40 to +70°C Temperature Class T4; Ta = -40 to +85°C	J
CSA for use in Ordinary (General Purpose) locations.	---	O
CSA intrinsically safe and nonincendive; Class I, Divisions 1 and 2, Groups A, B, C, and D. Also Class I, Zone 0, Ex ia IIC, and Class I, Zone 2 Ex nA.	Temperature Class T6; Ta = -40 to +55°C Temperature Class T5; Ta = -40 to +70°C Temperature Class T4; Ta = -40 to +85°C	D
CSA explosionproof, nonincendive, and dust-ignitionproof; Class I, II, III, Divisions 1 and 2, Groups A to G. Also Class I, Zone 1 Ex d IIC, and Class I, Zone 2 Ex nA.	Temperature Class T6; Ta = -40 to +55°C Temperature Class T5; Ta = -40 to +70°C Temperature Class T4; Ta = -40 to +85°C	G
CSA explosionproof, dust-ignitionproof, intrinsically safe, and nonincendive; Class I, II, III, Divisions 1 and 2, Groups A to G. Also Class I, Zone 1 Ex d IIC, Class I, Zone 0 Ex ia IIC, and Class I, Zone 2 Ex nA.	Temperature Class T6; Ta = -40 to +55°C Temperature Class T5; Ta = -40 to +70°C Temperature Class T4; Ta = -40 to +85°C	K
ATEX intrinsically safe; II 1 G, EEx ia IIC.	Temperature Class T6; Ta = -40 to +55°C Temperature Class T5; Ta = -40 to +70°C Temperature Class T4; Ta = -40 to +85°C	B
ATEX flameproof; II 2 G, EEx d IIC.	Temperature Class T6; Ta = -40 to +55°C Temperature Class T5; Ta = -40 to +70°C Temperature Class T4; Ta = -40 to +85°C	E
ATEX flameproof and intrinsically safe; EEx d and EEx ia.	See Codes B and E above	H
ATEX nonincendive; II 3 G, EEx nA nL IIC. See footnote (a).	Temperature Class T6; Ta = -40 to +55°C Temperature Class T5; Ta = -40 to +70°C Temperature Class T4; Ta = -40 to +85°C (a)	L
ATEX II 1/2 D; IP66/67.	Maximum Surface Temperature = 110°C	N
ATEX II 1/2 GD and EEx ia IIC.	Temperature Class T6; Ta = -40 to +55°C Temperature Class T5; Ta = -40 to +70°C Temperature Class T4; Ta = -40 to +85°C	T

(a) With ATEX II 3 G, EEx nL IIC, T4 = -40 to + 70°C (not +85°C) when an LCD Indicator is used.

MODEL CODE

Description	Model
Intelligent Temperature Transmitter with Two Signal Inputs	RTT30
Communication Protocol FOUNDATION Fieldbus	-K
Housing Aluminum Housing; No Indicator	1
Aluminum Housing; With Indicator	2
316L ss Housing; No Indicator	3
316L ss Housing; With Indicator	4
Cable Entry 1/2 NPT Threaded Connection	1
M20 x 1.5 Threaded Connection (a)	2
Mounting Sets None - Not Required	1
L-Shaped 304 ss Bracket, for Surface or Nominal DN 50 or 2-in Pipe Mounting	2
U-Shaped 316L ss Bracket, for Nominal DN 50 or 2-in Pipe Mounting	3
Electrical Safety (Also see Electrical Safety Specifications section) (c) None - Not used in Hazardous Areas	A
FM IS, NI I/1+2/ABCD; also Class I, Zones 0 and 2.	C
FM XP, NI, DIP, I, II, III/1+2/A-G; also Class I, Zones 1 and 2. (a)	F
FM XP, DIP, IS, NI I, II, III/1+2/A-G; also Class I, Zones 0, 1, and 2. (a)	J
CSA for use in Ordinary/General Purpose locations	O
CSA IS, NI I/1+2/ABCD; also Class I, Zones 0 and 2.	D
CSA XP, NI, DIP, I, II, III/1+2/A-G; also Class I, Zones 1 and 2.	G
CSA XP, DIP, IS, NI I, II, III/1+2/A-G; also Class I, Zones 0, 1, and 2.	K
ATEX II 1 G, EEx ia IIC, T4/T5/T6	B
ATEX II 2 G, EEx d IIC, T4/T5/T6	E
ATEX EEx d, EEx ia, T4/T5/T6	H
ATEX II 3 G, EEx nA nL IIC, T4/T5/T6	L
ATEX II 1/2 D; IP66/67	N
ATEX II 1/2 GD; EEx ia IIC, T4/T5/T6	T
Device Setup Factory Default Setup	A
Setup according to Configuration Sheet	B
Optional Selections Works Calibration Certificate; 6 Point Calibration, 60 Hz Filter (b)	-F1
Marking - Tag on Metal Plate; Information based on Submitted Configuration Sheet	-Z1
Example: RTT30-K213CB-F1Z1	

(a) The M20 threaded connection is not available with FM explosionproof approval Codes F and J.

(b) The Works Calibration Certificate is an evaluation and documentation of 6 fixed resistance values over the complete measuring range.

(c) Contact Invensys (see back page) for a listing of electrical approvals and certifications available at this time.

DIMENSIONS - NOMINAL

mm
in

ALUMINUM AND 316L SS HOUSING

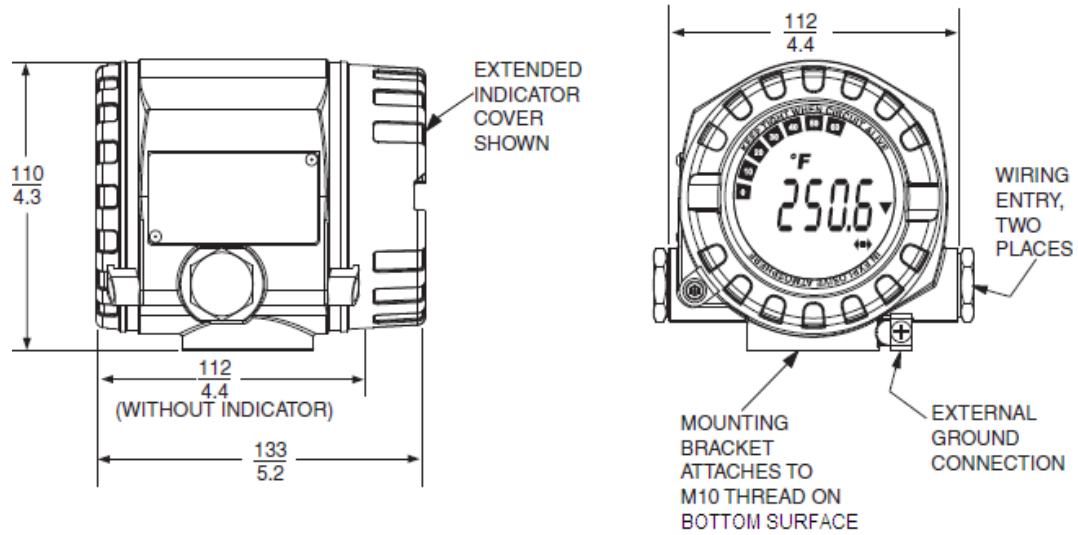

DIMENSIONS - NOMINAL (CONT.)
 $\frac{\text{mm}}{\text{in}}$

L-SHAPED MOUNTING BRACKET

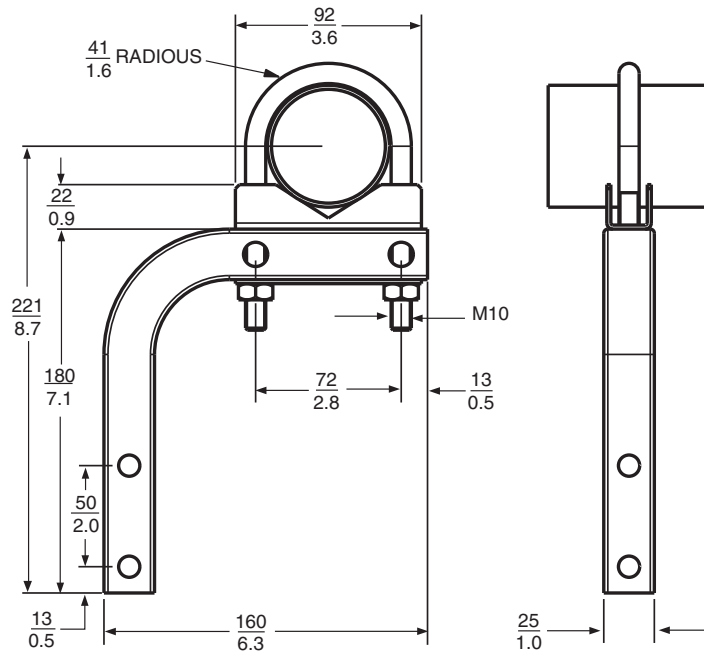

U-SHAPED MOUNTING BRACKET

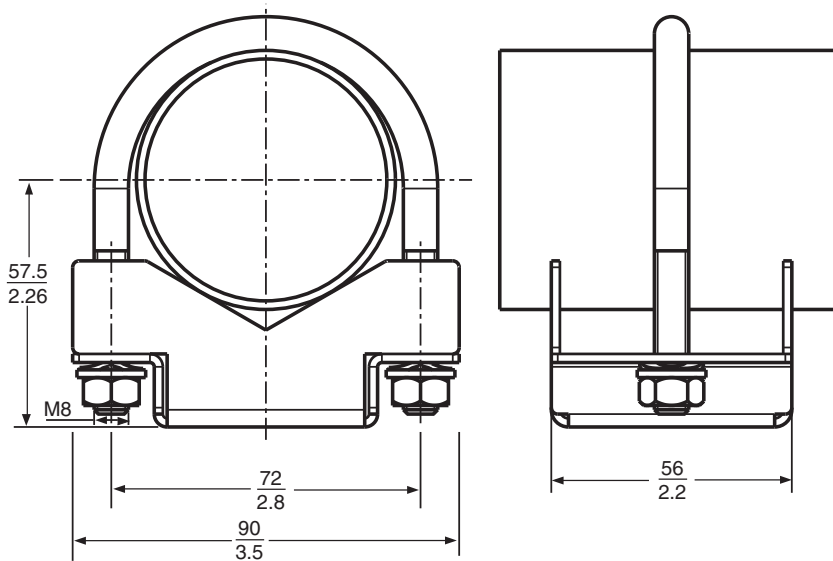

ORDERING INSTRUCTIONS

1. Transmitter Model Number.
2. Tag and Application.

OTHER M&I PRODUCTS

Invensys provides a broad range of measurement and instrument products, including solutions for pressure, flow, analytical, positioners, temperature, controlling and recording. For a listing of these offerings, visit the Invensys Operations Management web site at:

www.iom.invensys.com

Invensys Operations Management
5601 Granite Parkway Suite 1000
Plano, TX 75024
United States of America
<http://www.iom.invensys.com>

Global Client Support
Inside U.S.: 1-866-746-6477
Outside U.S.: 1-508-549-2424 or contact
your local Invensys representative.
Email: iom.support@invensys.com
Website: <http://support.iom.invensys.com>

Invensys and Foxboro are trademarks of Invensys plc, its subsidiaries, and affiliates.
All other brand names may be trademarks of their respective owners.

Copyright 2010 Invensys Systems, Inc.
All rights reserved

MB 010

1210