

**MODEL RTT30 Intelligent Temperature Transmitter  
with HART Communication Protocol**



*The Foxboro® brand Model RTT30 is a microprocessor based, full featured, high performance, 2-wire temperature transmitter. It receives input signals from thermocouples, RTDs, resistance (ohm), or voltage (mV) sources. It is offered with HART Communication Protocol.*

**FEATURES**

- ▶ Field-proven microprocessor-based transmitter ensures accurate measurement and performance.
- ▶ Remote Communication with HART Communicator or PC-based Configurator.
- ▶ Dual, independent sensor input capability for difference/average measurement, or sensor backup.
- ▶ Backlit indicator with measured value, bar graph, and fault indication displays designed for ease of reading.
- ▶ Drift alarm, sensor backup, and sensor corrosion detection enhances reliable operation.
- ▶ Sensor input-to-output galvanic isolation of 2 kV.
- ▶ Operation voltage monitoring for high measurement performance.
- ▶ Compact, dual compartment enclosure with fully potted electronics. Enclosure meets IP67 and NEMA 4X ratings.
- ▶ The stainless steel enclosure meets IP66/IP68 and NEMA 4x and NEMA 6P ratings.
- ▶ Aluminum or 316L ss housing offered to meet user's specific requirements.
- ▶ Approved/Certified by many testing agencies for use in hazardous area installations.
- ▶ Stainless steel mounting bracket sets offered for surface and nominal DN 50 or 2-in pipe mounting.
- ▶ Standard 2-year warranty.

## GENERAL DESCRIPTION

The Model RTT30 Intelligent Temperature transmitter is a universal and configurable temperature field transmitter with either one or two temperature sensor inputs for resistance thermometers (RTD), thermocouples (TC) and resistance and voltage transmitters. It is a full-featured, 2-wire transmitter with HART communication protocol. Digital output signals are provided in addition to an analog 4 to 20 mA output signal. Remote communication is provided with a HART Communicator or PC-based configurator. Input signals are received from RTDs and thermocouples, and also from resistance and millivolt sources. There can be two measuring inputs in 2-, 3-, or 4-wire connections (i.e., two 3-wire RTDs, or one 4-wire RTD and one TC), and the transmitter is mounted in a remote location. A backlit LCD Indicator can be provided that shows the current value digitally and as a bar graph with an indicator for alarms. See Figure 1 for typical installations, and also see the Backlit LCD Indicator paragraph and Figure 3 further in this document.

## DIGITAL HART AND 4 to 20 mA dc PROTOCOL

Configurable for either 4 to 20 mA or multidrop. Digital communication is based upon the FSK technique which alternately superimposes one of two different frequencies on the uninterrupted current carried by the two signal/power wires. Allows direct analog connection to common receivers while still providing full intelligent digital communications using a HART Communicator or PC-based configurator.

## 2-CHANNEL FUNCTIONS

These functions increase the reliability and availability of the process values, as follows:

- ▶ Hot Sensor Backup - Transmitter switches to redundant sensor if primary sensor fails.
- ▶ Temperature dependent switching between sensors, which have advantages in different ranges.

- ▶ Drift alert or alarm if sensor 1 and 2 deviate from one another.

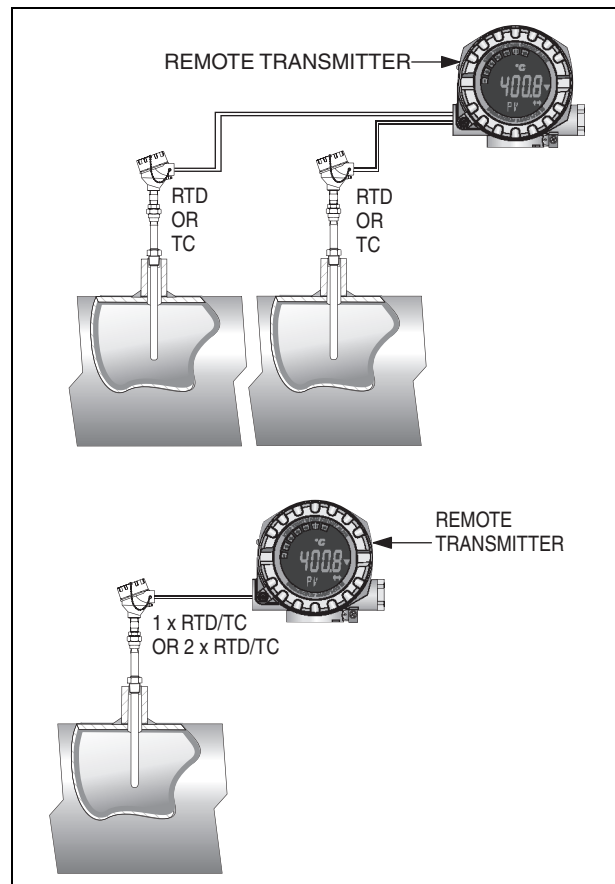

Figure 1. Typical Installations

## INPUT TYPES

This RTT30 Transmitter can be used with a wide variety of temperature sensors, including 2-, 3-, and 4-wire RTDs, most popular thermocouples, and other resistance and millivolt input devices. The following is a general list of transmitter input types:

- ▶ Platinum RTDs, 2-, 3-, and 4-wire
- ▶ Copper RTDs
- ▶ Nickel RTDs
- ▶ Thermocouples
- ▶ Millivolt Sources
- ▶ Ohm Sources

### EFFICIENT AND DURABLE

Industrial-grade integrated circuits and sealed electronics combine to make this microprocessor-based transmitter an efficient and durable device.

### HOUSING CONFIGURATIONS

The enclosure can be provided with an aluminum housing or with a stainless steel housing, each with or without an LCD indicator. Selections are offered for installations that require flameproof, explosionproof, intrinsically safe, and nonincendive certifications. Brackets are provided for remote mounting the enclosure. See paragraph below.

### MOUNTING BRACKET CONFIGURATIONS

The RTT30 can be supplied with either of two different mounting bracket configurations. A U-shaped bracket can be provided when only pipe mounting the enclosure to a nominal DN 50 or 2-in pipe is required; and an L-shaped bracket can be provided for use with either surface or pipe mounting the enclosure. The bracket material is stainless steel. See Figure 2.

### CORROSION DETECTION

Corrosion of the sensor connections can lead to corruption of the measured value. The transmitter is able to detect corrosion on thermocouples and RTDs with a 4-wire connection before measured value corruption occurs. The transmitter avoids false measurement readings and is also able to indicate a warning or error on the display when wire resistance exceeds reasonable values.

### LOW VOLTAGE DETECTION

Low voltage detection prevents the device from continuously outputting an incorrect analog output value (i.e. damaged/incorrect power supply or a damaged signal cable). If the required supply voltage is less than the low range limit, the analog output value drops  $< 3.6$  mA for approximately 3 s. An error message appears on the display. Afterwards the device tries to output the normal analog output value again. If the supply voltage is still too low, the analog output value drops again to  $< 3.6$  mA.

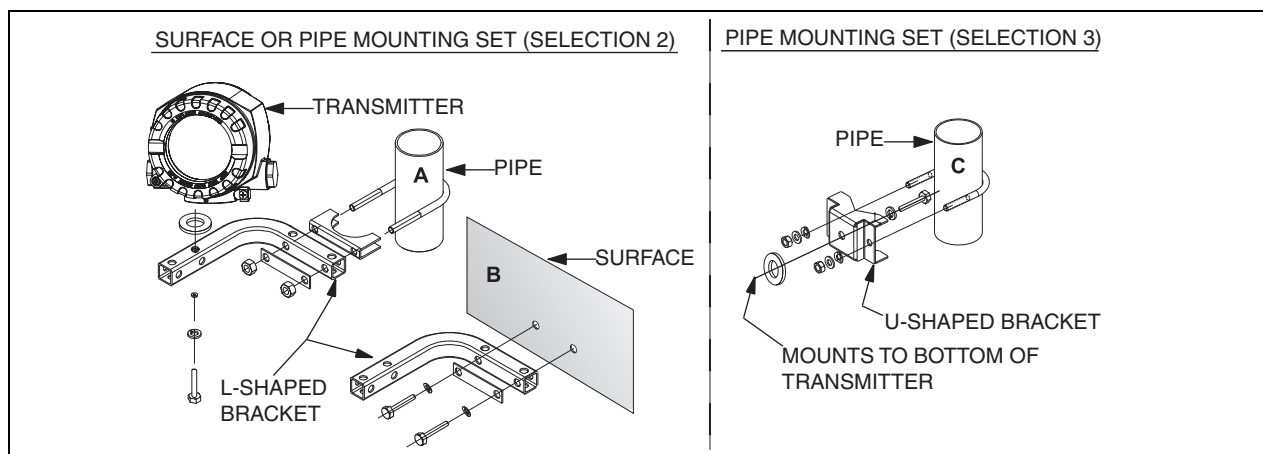

Figure 2. Transmitter Pipe or Surface Mounting Sets

### BACKLIT LCD INDICATOR

The indicator assembly with a backlit display can be plugged into the electronics compartment at 90° intervals. This allows flexibility in indicator orientation depending on transmitter installation. The engineering units display is in either K, °F, °C, or %. The measured value display character height is 20.5 mm (0.81 in). The display elements are shown in Figure 3 and described in Table 1.

**Table 1. Indicator Display Elements**

Display Elements	Description (a)
Bar Graph Display	In 10% increments with overrange and underrange marks. Display flashes when an error occurs.
WARNING Display	This is displayed whenever an error or WARNING is given.
Engineering Unit Display (EGU): K, °F, °C, or %	Measured value displayed in selected Engineering Units.
Measured Value Display: 20.5 mm (0.81 in) Character Height.	Displays measured value. If a WARNING is present, the display alternates between measured value and WARNING Code. In the event of an error, the Error Code is displayed rather than the measured value.
Status and Information Display	Indicates which value currently appears on the display. In the event of an error or warning, relevant error/warning information is displayed.
Communication Display	This communication icon appears and indicates that HART communication is active.
Configuration Locked Display	This icon is displayed when the configuration is locked via a hardware jumper.

(a) Refer to applicable Operation Manual for more specific details.

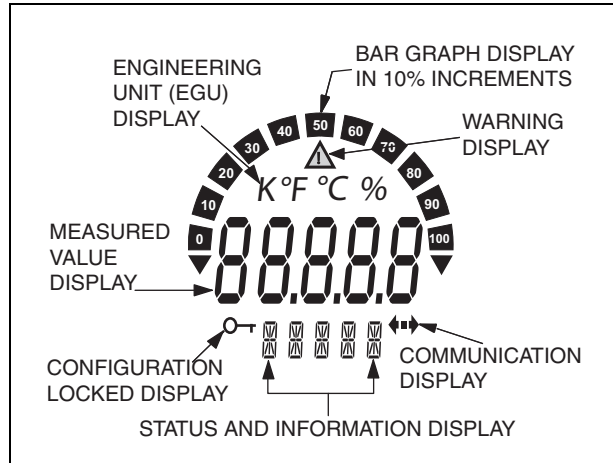

*Figure 3. Indicator Display Elements*

### USABLE IN HAZARDOUS AREA LOCATIONS

The Model RTT30 Temperature Transmitter meets the requirements of many certifying agencies for use in hazardous area locations. Refer to the ELECTRICAL SAFETY SPECIFICATIONS section for further details.

### EMI AND NAMUR COMPATIBILITY

Complies with the Electromagnetic Compatibility requirements of European EMC Directive 2004/108/EC, and also NAMUR Standards NE 21 and NE 43. See PERFORMANCE SPECIFICATIONS section.

### OPERATING, STORAGE, AND TRANSPORTATION CONDITIONS

Influence	Reference Operating Conditions	Operative Limits	Storage and Transportation Limits
Ambient Temperature ▶ Without Integral Indicator  ▶ With Integral Indicator	▶ 25 ±5°C (77 ±9°F)  ▶ 25 ±5°C (77 ±9°F)	▶ -40 and + 85°C (a) (-40 and +185°F) (a) ▶ -20 and + 80°C (a)(b) (-4 to +176°F) (a)(b)	▶ -40 and +100°C (-40 and +212°F) ▶ -40 and +80°C (-40 and +176°F)
Relative Humidity	50 ±10%	0 and 100% (c)	0 and 100% (c)
Supply Voltage (d) ▶ HART with Indicator ▶ HART without Indicator	▶ 24 ±0.5 V dc ▶ 24 ±0.5 V dc	▶ 18 and 40 V dc (e) ▶ 11 and 40 V dc (e)(f)	N/A
Altitude	Sea Level	Up to 2000 m (6560 ft)	N/A
Shock and Vibration Resistance	Negligible	0 and 30 m/s <sup>2</sup> (0 and 3 "g") from 2 to 150 Hz (g)	107 mm (42 in) Drop in Shipping Container

- (a) Refer to Electrical Safety Specifications section for a restriction in ambient temperature with certain agency approvals and certifications.
- (b) The LCD Indicator display may react slowly at temperatures below -20°C (below -4°F); Readability of the display cannot be guaranteed at temperatures below -30°C (below -22°F).
- (c) Condensation permitted.
- (d) Supply voltage values listed are with reverse polarity protection.
- (e) Minimum load required with HART Communicator or PC-based Configurator is 250 Ω Operating below the 250 Ω requirement may cause communication problems. See Figure 4.
- (f) For units without an Indicator, the supply voltage can be reduced to 8 V dc by means of a jumper in the electronics compartment.
- (g) Per IEC 60068-2-6.

### PERFORMANCE SPECIFICATIONS

Under Reference Operating Conditions unless Otherwise Specified

#### Measurement Accuracy

Sensor Type	Sensor Designation	Measurement Accuracy	
		Digital	D/A (a)
RTD	Cu100, Ni100, Ni120, Pt100	0.1°C (0.18°F)	0.02%
	Cu50, Ni1000, Pt50, Pt1000	0.2°C (0.36°F)	0.02%
	Pt500	0.3°C (0.54°F)	0.02%
	Cu10, Pt200	1.0°C (1.8°F)	0.02%
Thermocouple	Types E, J, K, L, T, U	0.25°C (0.45°F) (b)	0.02%
	Types N, C, D	0.5°C (0.9°F) (b)	0.02%
	Types B, R, S	1.0°C (1.8°F) (b)	0.02%
Input Source	Measurement Range	Measurement Accuracy	
		Digital	Analog (a)
Voltage Transmitter	-20 to +100 mV	±10 μV	±0.02%
Resistance Transmitter	10 to 400 Ω	±0.04 Ω	0.02%
	10 to 2000 Ω	±0.08 Ω	0.02%

- (a) The % relates to the set span. For the 4 to 20 mA analog output, Accuracy = Digital Accuracy + D/A Accuracy.
- (b) Thermocouple Digital Accuracies listed are typical values.

**PERFORMANCE SPECIFICATIONS (CONT.)**

**Response Time**

1 second per channel

**Repeatability**

±0.0015% of the input range of the sensors. See Table 2 for the sensor input range with each sensor type.

**Long Term Stability**

≤0.1°C (≤0.18°F) per year; or  
 ≤0.05% per year (relates to set span).

**NOTE**

Stability is the larger of the temperature or percent (%) values specified above.

**Ambient Temperature Effect (Temperature Drift)**

Ambient temperature effect values listed below are for a 1°C (1.8°F) change in ambient temperature within operative limits.

- ▶ 10 to 400 Ω Input: Typical, 0.001% of measured value, with a minimum value of 1 mΩ
- ▶ 10 to 2000 Ω Input: Typical, 0.001% of measured value, with a minimum value of 10 mΩ
- ▶ -20 to +100 mV Input: Typical, 0.001% of measured value, with a minimum value of 0.2 μV.
- ▶ -5 to +30 mV Input: Typical, 0.001% of measured value, with a minimum value of 10 μV.
- ▶ 4 to 20 mA Output: 0.001% of span, typical; with a Maximum Value of 1.5 x Typical Value.

**NOTE**

Total temperature drift = input temperature drift + output temperature drift.

**Sensitivity**

See Table 3 for typical sensitivity of RTDs, and see Table 4 for typical sensitivity of thermocouples.

**Table 2. Sensor Input Range**

Sensor Type	Input Range
RTD: Cu10, Cu50, Cu100, Ni100, Ni120, Pt50, Pt100	10 to 400 Ω
RTD: Ni1000, Pt200, Pt500, Pt1000	10 to 2000 Ω
Thermocouple: Types B, R, S, T	-5 to +30 mV
Thermocouple: Types C, D, E, J, K, L, N, U	-20 to +100 mV

**Table 3. Typical Sensitivity of RTDs**

RTD Type	Typical Sensitivity (a)
Pt	(0.00385) (Rnominal/K)
Cu	(0.0043) (Rnominal/K)
Ni	(0.00617) (Rnominal/K)

(a) For example, for Pt100 RTD;  
 Typical Sensitivity = (0.00385)(100 Ω/K) = 0.385 Ω/K.

**Table 4. Typical Sensitivity of Thermocouples**

Typical Sensitivity			
TC Type	Sensitivity	TC Type	Sensitivity
B	10 μV/K	K	40 μV/K
R	12 μV/K	T	50 μV/K
S	12 μV/K	J	55 μV/K
C	20 μV/K	L	55 μV/K
D	20 μV/K	U	60 μV/K
N	35 μV/K	E	75 μV/K

**Supply Voltage Effect**

**DIGITAL SIGNAL**

None

**4 to 20 mA SIGNAL**

±0.005% per V change within the specified voltage range.

## PERFORMANCE SPECIFICATIONS (CONT.)

### Compliance with European Union Directives

The transmitter, when installed in accordance with the applicable installation instruction (MI), complies with the EMC requirements of European EMC Directive 2004/108/EC by conforming to the following EN and IEC Standards: EN 61326-1, IEC 61000-4 (as listed below), and NAMUR Standards NE 21 and NE 43 (as listed below).

- ▶ Electrostatic Discharge per IEC 61000-4-2:  
6 kV Cont., 8 kV air.
- ▶ Radiated RF Immunity per IEC 61000-4-3:
  - 0.08 to 2.0 GHz; 10 V/m
  - 80 to 750 MHz: 30 V/m
  - 1.4 to 2 GHz: 30 V/m
- ▶ High Frequency Transient per IEC 61000-4-4:  
2 kV
- ▶ Switching and Indirect Lightning Transient (Surge) per IEC 61000-4-5:  
0.5 kV symmetrical
- ▶ Conducted RF Immunity per IEC 61000-4-6:  
0.01 to 80 MHz; 10 V
- ▶ Interference Immunity requirements per NAMUR NE 21.
- ▶ Analog Output Over-range and Under-range Annunciations per NAMUR NE 43.

### Measuring Category

Measuring Category II per IEC 61010-1. The measuring category is provided for measurements at circuits with a direct electrical connection to the low voltage supply.

### Installation Category

Installation Category 1 to IEC 61010.

### Pollution Degree

Pollution degree 2 per IEC 61010.

### Climate Class

Climate Class per IEC 60654-1, Class C.

**FUNCTIONAL SPECIFICATIONS**

**Span and Range Limits**

**RTD INPUT**

See Table 3

**THERMOCOUPLE INPUT**

See Table 4

**VOLTAGE INPUT**

See Table 5

**RESISTANCE INPUT**

See Table 5

**Table 5. RTD Input - Span and Range Limits**

RTD Designation and Description	Measurement Range Limits	Minimum Span
Cu10 alpha = 0.004274; To Edison Copper Winding No. 15	-100 and +260°C (-148 and +500°F)	10°C (18°F)
Cu50 alpha = 0.004278; To GOST	-200 and +200°C (-328 and +392°F)	10°C (18°F)
Cu100 alpha = 0.004278; To GOST	-200 and +200°C (-328 and +392°F)	10°C (18°F)
Ni100 alpha = 0.006180; To DIN 43760	-60 and +250°C (-76 and +482°F)	10°C (18°F)
Ni120 alpha = 0.006720; To Edison Curve	-70 and +270°C (-94 and +518°F)	10°C (18°F)
Ni1000 alpha = 0.006180; To DIN 43760	-60 and +150°C (-76 and +302°F)	10°C (18°F)
Pt50 alpha = 0.003911; To GOST	-200 and +1100°C (-328 and +2012°F)	10°C (18°F)
Pt100 alpha = 0.003916; To JIS C1604-81	-200 and +649°C (-328 and +1200°F)	10°C (18°F)
Pt100 alpha = 0.003911; To GOST	-200 and +850°C (-328 and +1562°F)	10°C (18°F)
Pt100 alpha = 0.00385; To IEC 60751	-200 and +850°C (-328 and +1562°F)	10°C (18°F)
Pt200 alpha = 0.00385; To IEC 60751	-200 and +850°C (-328 and +1562°F)	10°C (18°F)
Pt500 alpha = 0.00385; To IEC 60751	-200 and +250°C (-328 and 482°F)	10°C (18°F)
Pt1000 alpha = 0.00385; To IEC 60751	-200 and +250°C (-328 and +482°F)	10°C (18°F)



**FUNCTIONAL SPECIFICATIONS (CONT.)**  
**Table 6. Thermocouple Inputs - Span and Range Limits**

Thermocouple Designation and Description	Measurement Range Limits	Minimum Span
Type T Cu-CuNi; IEC 584-1	-270 and +400°C (-454 and +752°F)	50°C (90°F)
Type E NiCr-CuNi; IEC 584-1	-270 and +1000°C (-454 and +1832°F)	50°C (90°F)
Type N NiCrSi-NiSi; IEC 584-1	-270 and +1300°C (-454 and 2372°F)	50°C (90°F)
Type K NiCr-Ni; IEC 584-1	-270 and +1372°C (-454 and +2501°F)	50°C (90°F)
Type J Fe-CuNi; IEC 584-1	-210 and +1200°C (-346 and +2192°F)	50°C (90°F)
Type U Cu-CuNi; IEC 43710	-200 and +600°C (-328 and +1112°F)	50°C (90°F)
Type L Fe-CuNi; DIN 43710	-200 and +900°C (-328 and +1652°F)	50°C (90°F)
Type R PtRh13-Pt; IEC 584-1	-50 and +1768°C (-58 and +3214°F)	500°C (900°F)
Type S PtRh10-Pt; IEC 584-1	-50 and +1768°C (-58 and +3214°F)	500°C (900°F)
Type B (a)(b) PtRh30-PtRh6; IEC 584-1	0 and 1820°C (32 and 3308°F)	500°C (900°F)
Type C W5Re-W26Re; ASTM E988	0 and 2320°C (32 and 4208°F)	500°C (900°F)
Type D W3Re-W25Re; ASTM E988	0 and 2495°C (32 and 4523°F)	500°C (900°F)

- (a) The measuring error (see Table 1) will increase for temperatures lower than 300°C (572°F).  
 (b) When operation conditions are based on a large temperature range, the RTT30 offers the ability to split the range. For example, a Type S or R thermocouple can be used for the low range, while a Type B can be used for the upper range.

**Table 7. Voltage and Resistance Inputs - Span and Range Limits**

Input Source	Measurement Range Limits	Minimum Span
Voltage Transmitter	-20 and +100 mA	5 mV
Resistance Transmitter	10 and 400 Ω	10 Ω
Resistance Transmitter	10 and 2000 Ω	100 Ω

**FUNCTIONAL SPECIFICATIONS (CONT.)**

**Output Signal**

- ▶ Analog Output: 4 to 20 mA or 20 to 4 mA.  
Requires a minimum loop load of 250 Ω for proper communication.
- ▶ Signal Encoding: Digital Communications provided based upon the FSK (Frequency Shift Keying) technique; ± 0.5 mA via the current signal.
- ▶ Data Transmission Rate: 1200 baud
- ▶ Galvanic Isolation: 2 kV ac (Input/Output)

**Fault Information (Per NAMUR NE 43)**

- ▶ Underrange: Linear drop to 3.8 mA
- ▶ Overrange: Linear rise to 20.5 mA
- ▶ Failure (e.g., sensor break or short circuit): ≤ 3.6 mA low, or ≥ 21 mA high; selectable. The high alarm is adjustable between 21.6 and 23 mA, thus allowing for flexibility when working with control system requirements.

**Current Consumption**

- ▶ Basic Current: 3.6 to 22 mA
- ▶ Current Consumption limits: 3.5 and 23 mA.

**Filter**

1st order digital filter: 0 to 60 s

**Warm-Up Time**

4 s during switch-on operation;  $I_a \leq 3.8$  mA

**Write Protect Function**

This function locks out all configurators from making transmitter configuration changes. This makes transmitter suitable for Safety Shutdown System Applications that require this feature. This feature is activated by a jumper in the electronics compartment.

**Supply Voltage Requirements and External Loop Load Limitations**

Nominal supply voltage is 11 to 40 V dc. Also, with an LCD Indicator, the minimum voltage increases to 18 V dc. A minimum loop load of 250 Ω is required when a HART Communicator or PC-based Configurator is used. See Figure 5.

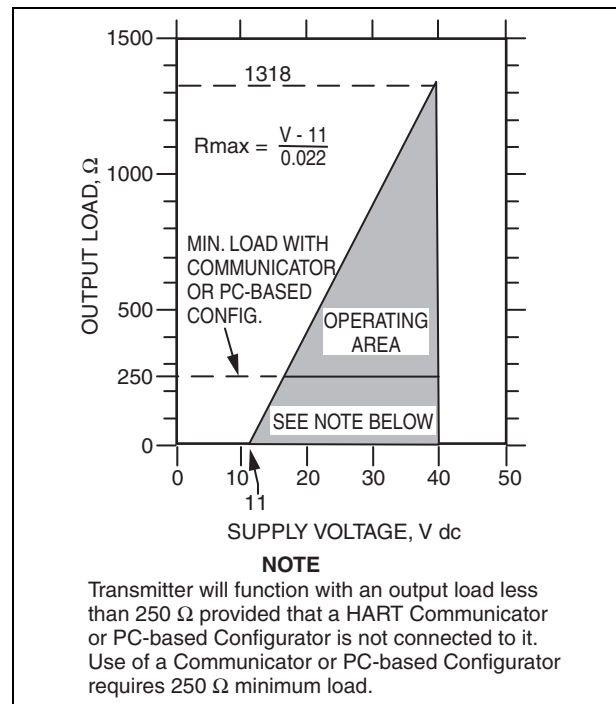

Figure 4. HART 4 to 20 mA Analog Output, Supply Voltage vs Output Load

**Reduced Supply Voltage**

For transmitters without an LCD Indicator, the supply voltage can be reduced from 11 to 8 V dc. A jumper is provided in the electronics compartment for this purpose.

## PHYSICAL SPECIFICATIONS

### Enclosure Material

- ▶ Die-cast aluminum housing with a powder coating on a polyester base.
- ▶ 316L stainless steel housing.

### Enclosure Construction

A dual compartment enclosure, one for the electronics and one for the cable entry and electrical connections. The compartment covers are threaded and include O-rings to seal the enclosure. Cover clamp kits are provided to prevent cover rotation.

### Enclosure Mounting

Surface or pipe mounting brackets can be provided with the enclosure. An L-shaped 304 ss bracket is offered for either surface or pipe mounting the transmitter. The bracket is 25 mm (1 in) square tubing with one leg 163 mm (6.4 in) long, and the other leg 183 mm (7.2 in) long. A U-shaped 316L ss bracket is offered for pipe mounting only. Either bracket is for attaching to a nominal DN 50 or 2-in pipe using a U-bolt.

### Electronics Assembly

Fully potted electronics provide environmental protection.

### LCD Indicator

The indicator is located in the electronics compartment, and can be plugged in at 90° intervals. This allows flexibility in display orientation, depending on the transmitter's installation location.

### Electrical Connections

Two 1/2 NPT or M20 threaded connections are provided on the housing for cable or wire entry. Also an external grounding connection is located at the lower surface of the housing.

### Sensor Installation

The thermocouple or RTD is typically installed in a remote location. Contact Invensys if direct fitting of the sensor to the transmitter is desired.

### Environmental Protection

The enclosure has the dusttight and weatherproof rating of IP67 as defined by IEC 60529, and provides the environmental and corrosion resistant protection rating of NEMA 4X.

The stainless steel housing has a rating for hygienic applications of IP66/IP68 and provides environmental and corrosion resistant protection rating of NEMA 4x, and NEMA 6P.

### Approximate Weight

#### ALUMINUM HOUSING WITH INDICATOR

1.4 kg (3.1 lb)

#### 316L ss HOUSING WITH INDICATOR

4.2 kg (9.3 lb)

### Dimensions

Refer to DIMENSIONS-NOMINAL section.

**ELECTRICAL SAFETY SPECIFICATIONS**

Testing Laboratory, Types of Protection, and Area Classification	Application Conditions	Elec. Safety Design Code
None - Instrument in a nonhazardous area location.		A
<b>FM</b> intrinsically safe and nonincendive; Class I, Divisions 1 and 2, Groups A, B, C, and D. Also Class I, Zone 0 AEx ia IIC, and Class I, Zone 2 AEx nA.	Temperature Class T4; Ta = -40 to +85°C	C
<b>FM</b> explosionproof, nonincendive, and dust-ignitionproof; Class I, II, III, Divisions 1 and 2, Groups A to G. Also Class I, Zone 1 AEx d IIC, and Class I, Zone 2 AEx nA.	Temperature Class T6; Ta = -40 to +55°C Temperature Class T5; Ta = -40 to +70°C Temperature Class T4; Ta = -40 to +85°C	F
<b>FM</b> explosionproof, dust-ignitionproof, intrinsically safe, and nonincendive; Class I, II, III, Divisions 1 and 2, Groups A to G. Also Class I, Zone 1 AEx d IIC, Class I, Zone 0 AEx ia IIC, and Class I, Zone 2 AEx nA.	Temperature Class T6; Ta = -40 to +55°C Temperature Class T5; Ta = -40 to +70°C Temperature Class T4; Ta = -40 to +85°C	J
<b>CSA</b> for use in Ordinary (General Purpose) locations.	---	O
<b>CSA</b> intrinsically safe and nonincendive; Class I, Divisions 1 and 2, Groups A, B, C, and D. Also Class I, Zone 0, Ex ia IIC, and Class I, Zone 2 Ex nA.	Temperature Class T6; Ta = -40 to +55°C Temperature Class T5; Ta = -40 to +70°C Temperature Class T4; Ta = -40 to +85°C	D
<b>CSA</b> explosionproof, nonincendive, and dust-ignitionproof; Class I, II, III, Divisions 1 and 2, Groups A to G. Also Class I, Zone 1 Ex d IIC, and Class I, Zone 2 Ex nA.	Temperature Class T6; Ta = -40 to +55°C Temperature Class T5; Ta = -40 to +70°C Temperature Class T4; Ta = -40 to +85°C	G
<b>CSA</b> explosionproof, dust-ignitionproof, intrinsically safe, and nonincendive; Class I, II, III, Divisions 1 and 2, Groups A to G. Also Class I, Zone 1 Ex d IIC, Class I, Zone 0 Ex ia IIC, and Class I, Zone 2 Ex nA.	Temperature Class T6; Ta = -40 to +55°C Temperature Class T5; Ta = -40 to +70°C Temperature Class T4; Ta = -40 to +85°C	K
<b>ATEX</b> intrinsically safe; II 1 G, EEx ia IIC.	Temperature Class T6; Ta = -40 to +55°C Temperature Class T5; Ta = -40 to +70°C Temperature Class T4; Ta = -40 to +85°C	B
<b>ATEX</b> flameproof; II 2 G, EEx d IIC.	Temperature Class T6; Ta = -40 to +55°C Temperature Class T5; Ta = -40 to +70°C Temperature Class T4; Ta = -40 to +85°C	E
<b>ATEX</b> flameproof and intrinsically safe; EEx d and EEx ia.	See Codes B and E above	H
<b>ATEX</b> nonincendive; II 3 G, EEx nA nL IIC. See footnote (a).	Temperature Class T6; Ta = -40 to +55°C Temperature Class T5; Ta = -40 to +70°C Temperature Class T4; Ta = -40 to +85°C (a)	L
<b>ATEX</b> II 1/2 D; IP66/67.	Maximum Surface Temperature = 110°C	N
<b>ATEX</b> II 1/2 GD and EEx ia IIC.	Temperature Class T6; Ta = -40 to +55°C Temperature Class T5; Ta = -40 to +70°C Temperature Class T4; Ta = -40 to +85°C	T

(a) With ATEX II 3 G, EEx nL IIC, T4 = -40 to + 70°C (not +85°C) when an LCD Indicator is used.

**MODEL CODE**

<b>Description</b>	<b>Model</b>
Intelligent Temperature Transmitter with Two Signal Inputs	RTT30
<b>Communication Protocol</b>	
Digital HART and 4 to 20 mA dc	-A
<b>Housing</b>	
Aluminum Housing; No Indicator	1
Aluminum Housing; With Indicator	2
316L ss Housing; No Indicator	3
316L ss Housing; With Indicator	4
<b>Cable Entry</b>	
1/2 NPT Threaded Connection	1
M20 x 1.5 Threaded Connection (a)	2
<b>Mounting Sets</b>	
None - Not Required	1
L-Shaped 304 ss Bracket, for Surface or Nominal DN 50 or 2-in Pipe Mounting	2
U-Shaped 316L ss Bracket, for Nominal DN 50 or 2-in Pipe Mounting	3
<b>Electrical Safety (Also see Electrical Safety Specifications section) (c)</b>	
None - Not used in Hazardous Areas	A
FM IS, NI I/1+2/ABCD; also Class I, Zones 0 and 2.	C
FM XP, NI, DIP, I, II, III/1+2/A-G, also Class I, Zone 1 and 2. (a)	F
FM XP, DIP, IS, NI I, II, III/1+2/A-G; also Class I, Zones 0, 1, and 2. (a)	J
CSA for use in Ordinary/General Purpose locations	O
CSA IS, NI I/1+2/ABCD; also Class I, Zones 0 and 2.	D
CSA XP, NI, DIP, I, II, III/1+2/A-G; also Class I, Zones 1 and 2.	G
CSA XP, DIP, IS, NI I, II, III/1+2/A-G; also Class I, Zones 0, 1, and 2.	K
ATEX II 1 G, EEx ia IIC, T4/T5/T6	B
ATEX II 2 G, EEx d IIC, T4/T5/T6	E
ATEX EEx d, EEx ia, T4/T5/T6	H
ATEX II 3 G, EEx nA nL IIC, T4/T5/T6	L
ATEX II 1/2 D; IP66/67	N
ATEX II 1/2 GD; EEx ia IIC, T4/T5/T6	T
<b>Device Setup</b>	
Factory Default Setup	A
Setup according to Configuration Sheet	B
<b>Optional Selections</b>	
Works Calibration Certificate; 6 Point Calibration, 60 Hz Filter (b)	-F1
Marking - Tag on Metal Plate; Information based on submitted Configuration Sheet	-Z1
Example: RTT30-A213CB-F1Z1	

(a) The M20 threaded connection is not available with FM explosionproof approval Codes F and J.

(b) The Works Calibration Certificate is an evaluation and documentation of 6 fixed resistance values over the complete measuring range.

(c) Contact Invensys for a listing of electrical approvals and certifications available at this time.

DIMENSIONS - NOMINAL

mm  
in

ALUMINUM AND 316L SS HOUSING

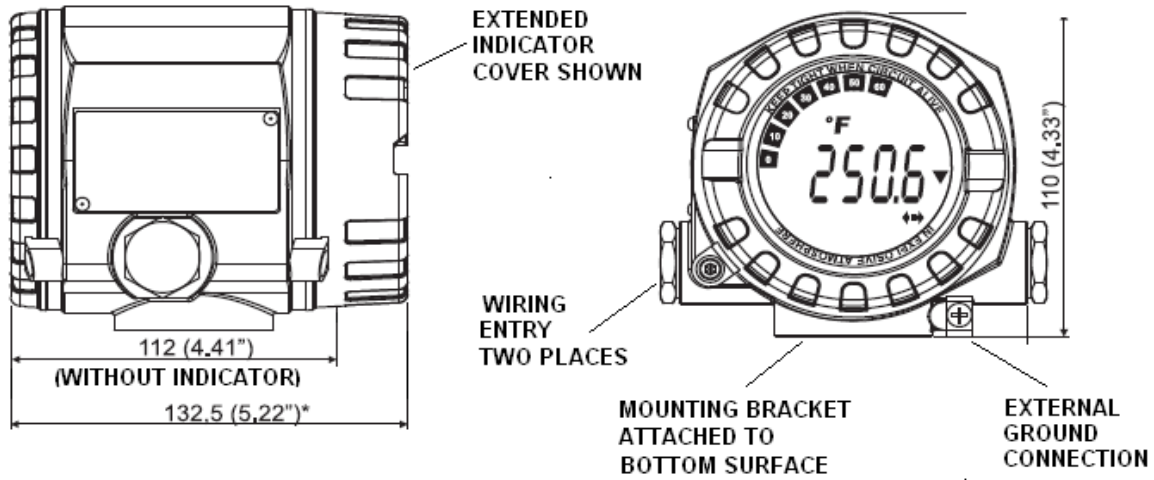

DIMENSIONS - NOMINAL (CONT.)

$\frac{\text{mm}}{\text{in}}$

L-SHAPED MOUNTING BRACKET

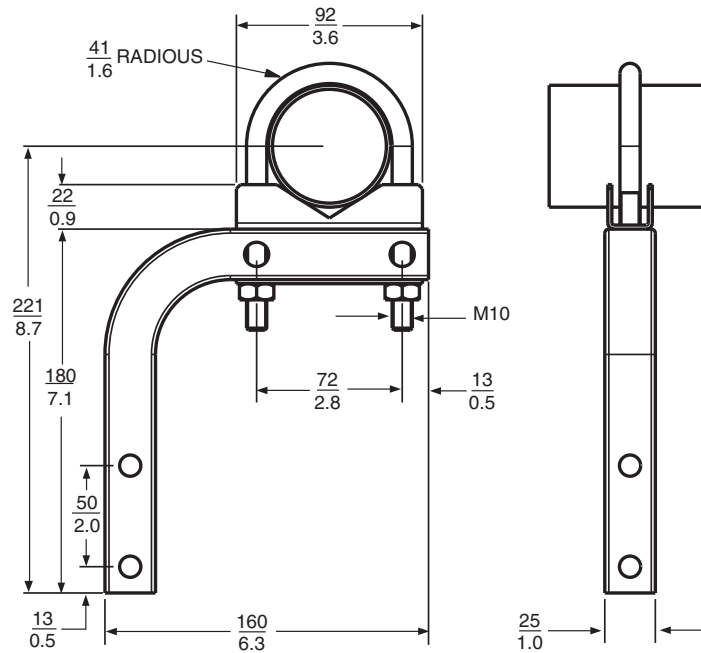

U-SHAPED MOUNTING BRACKET

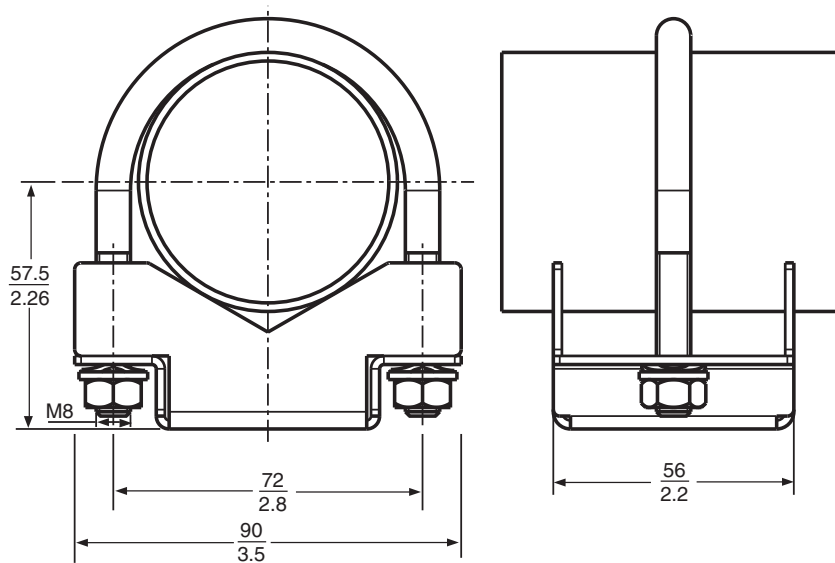

## ORDERING INSTRUCTIONS

1. Transmitter Model Number.
2. Tag and Application.

## OTHER M&I PRODUCTS

Invensys provides a broad range of measurement and instrument products, including solutions for pressure, flow, analytical, positioners, temperature, controlling and recording. For a listing of these offerings, visit the Invensys Operations Management web site at:

[www.iom.invensys.com](http://www.iom.invensys.com)

Invensys Operations Management  
5601 Granite Parkway Suite 1000  
Plano, TX 75024  
United States of America  
<http://www.iom.invensys.com>

Global Client Support  
Inside U.S.: 1-866-746-6477  
Outside U.S.: 1-508-549-2424 or contact  
your local Invensys representative.  
Email: [iom.support@invensys.com](mailto:iom.support@invensys.com)  
Website: <http://support.iom.invensys.com>

Invensys and Foxboro are trademarks of  
Invensys plc, its subsidiaries, and affiliates.  
All other brand names may be trademarks of their  
respective owners.

Copyright 2010 Invensys Systems, Inc.  
All rights reserved

MB 010