

**RTT20**  
**I/A Series<sup>®</sup> Temperature Transmitter**

**Installation, Configuration, Operation,  
Calibration, and Maintenance**

**Style A**



# Contents

Figures.....	v
Tables.....	vi
<b>1. Introduction .....</b>	<b>1</b>
General Description .....	1
Transmitter Identification .....	2
Reference Documents .....	2
Standard Specifications .....	3
Operating Conditions .....	3
Functional Specifications .....	4
Physical Specifications .....	8
Electrical Certification Rating .....	8
Electrical Safety Specifications .....	9
ATEX Warning .....	10
IECEX Warning .....	10
FM and CSA Warnings .....	11
ATEX Compliance Documents .....	11
CENELEC Compliance Documents .....	11
IECEX Compliance Documents .....	11
<b>2. Installation .....</b>	<b>13</b>
Unpacking .....	13
Transmitter Mounting .....	13
DIN Rail Mount .....	13
Pipe or Surface Mount .....	14
Surface Mount without Bracket .....	14
Bare Sensor Mount .....	14
Thermowell Mount .....	15
Mounting Basic Transmitter in Old Style Housing .....	15
Positioning Transmitter to View Optional Indicator .....	16
Cover Lock .....	16
Transmitter Wiring .....	17
Power Supply Requirements for HART Transmitters .....	17
Conduit Drainage .....	17
Hazardous Locations .....	18
Sensor Connections and Wiring .....	20
Loop Wiring .....	23
Grounding (Earthing) .....	27
HART Multidrop Communication .....	27

<b>3. Operation</b> .....	<b>29</b>
<b>4. Configuration</b> .....	<b>31</b>
Configurable Parameters .....	31
Parameter Descriptions .....	35
Indicator/Configurator .....	38
Configuration Procedure .....	40
<b>5. Calibration</b> .....	<b>43</b>
Trimming 4 to 20 mA Output .....	43
Input Calibration .....	44
N-Point Calibration .....	44
Custom Curve Calibration .....	44
<b>6. Maintenance</b> .....	<b>47</b>
Troubleshooting Problems .....	47
Replacement of Integrally Mounted Sensor .....	51
Replacement of Basic Transmitter .....	51
<b>Index</b> .....	<b>53</b>

# Figures

1	Transmitter Identification .....	2
2	DIN Rail Mount .....	13
3	Pipe or Surface Mount .....	14
4	Surface Mount without Bracket (Rear View) .....	14
5	Bare Sensor Mount .....	14
6	Thermowell Mount .....	15
7	Locating New Holes in Existing Mounting Plate .....	16
8	Cover Lock .....	16
9	Recommended Conduit Routing .....	18
10	Single RTD Wiring .....	20
11	Dual RTD Wiring .....	21
12	Thermocouple or Voltage Wiring .....	22
13	Typical Transmitter Wiring to an I/A Series System .....	24
14	Voltage and Load Limits .....	25
15	Typical Transmitter Wiring with a 4 to 20 mA Output .....	26
16	Wiring Several 4 to 20 mA Transmitters to a Common Power Supply .....	27
17	Typical Multidrop Network .....	28
18	3-Line Indicator .....	39
19	Addition of Indicator/Configurator .....	39
20	Indicator Configurator Flowchart .....	41
21	4 to 20 mA Output Calibration Setup .....	43
22	Input Calibration Setup .....	44

# Tables

1	Reference Documents .....	2
2	Operating Conditions .....	3
3	Input Types .....	6
4	Range Limits, Maximum Span, and Accuracy <sup>(a)</sup> .....	7
5	Electrical Safety Specifications .....	9
6	RTT20 with Intelligent Output (Code -D) .....	32
7	RTT20 with HART Output (Code -T) .....	33
8	RTT20 with 4 to 20 mA Output (Code -I) .....	34

# 1. Introduction

## General Description

The RTT20 I/A Series Temperature Transmitter is a microprocessor-based, two-wire device for converting various mV and ohm type sensors into a linear 4 to 20 mA or digital output. A standard two-wire system provides a nominal 24 V dc power to the transmitter and also carries the output signal to a receiver tied into the loop wiring. There are three different output types with communications capabilities as follows:

Output Code -I: 4 to 20 mA without remote communications

Output Code -T: 4 to 20 mA output with HART communication

Output Code -D: 4 to 20 mA or FoxCom™ digital communication

The microprocessor-based transmitter was designed for easy installation in a wide variety of applications. The major differences between the three output types is in communications. The optional 1-Line and 3-Line Indicator/Configurators are designed to enable the user to locally reconfigure any transmitter database. A single indicator can be easily moved from one transmitter to another. No tools are required to install or remove it. Simply plug it in and make the desired adjustments to the transmitter. Then remove it and move on to the next transmitter. The 4 to 20 mA transmitter (Output Code -I) can only be adjusted using these Indicator/Configurators because there is no remote communications capability. Whenever the local Indicator/Configurators are used for reconfigurations, the loop must be put in manual. As a safety feature, the output will be held at the last value until the transmitter is returned to the operational mode.

The HART and FoxCom protocol transmitters have an internal modem to enable the database to be remotely reranged or reconfigured as follows:

HART protocol – with a HART Communicator or a Foxboro PC-based configurator.

FoxCom protocol – with a PC-Based Configurator and/or from an I/A Series system.

All of the remote configurators can communicate with the transmitter from any wiring termination point in the loop. This allows the transmitter to be installed in hazardous locations or areas which are not at grade level. The configurator can only be used in an area for which it is rated. Communication between the remote configurator and the transmitter is based upon the Frequency Shift Keying (FSK) technique. Since the FSK tones do not add any current to the two-wire system, reading transmitter data does not interfere with the output signal. When new configuration data is being downloaded into the transmitter, however, the output is interrupted and the loop must therefore be put in manual. The transmitter with FoxCom protocol can also be digitally integrated into an I/A Series System and reconfigured with any of the system workstations, eliminating the need for the separate configurator.

The microprocessor-based transmitter has been designed to accept a wide variety of mV and resistive sensors:

- ◆ Thermocouples
- ◆ RTDs (2, 3 or 4 wire)
- ◆ Millivolt dc sources
- ◆ Resistive Sensors (Ohms measurement)

◆ Dewpoint Sensors (Foxboro Model 2781)

The input and output characteristics are determined by the configuration information loaded into the transmitter at the factory. This configuration can be easily changed using the Indicator/Configurators or any of the various remote configurators.

## Transmitter Identification

See Figure 1 for typical transmitter data plate contents. For a complete explanation of the Model Number code, see PL 008-659.

— **NOTE** —

Figure 1 shows a typical data plate. For a recapitulation of the specific information that applies to each agency certification, see “Electrical Certification Rating” on page 8.

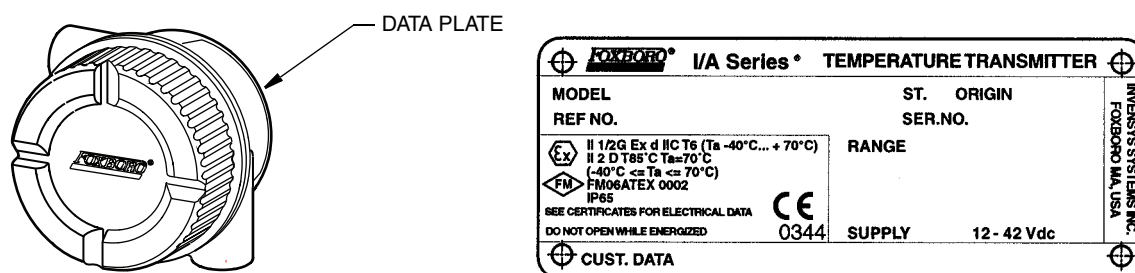

Figure 1. Transmitter Identification

## Reference Documents

This document contains information on installation, configuration, operation, calibration, and maintenance of the RTT20 Transmitter. Additional information about the transmitter and the remote configurators are contained in the documents listed in Table 1.

Table 1. Reference Documents

Document	Description
MI 020-460	Operation, Calibration, and Configuration Using a HART Communicator
MI 020-484	HART Model 275 Communicator Messages
MI 020-495	PC20 Intelligent Transmitter Configurator
MI 020-501	PC50 Intelligent Field Device Tool (Installation and Parts List)
MI 020-504	PC50 Intelligent Field Device Tool (Operation Using HART Protocol)
MI 020-505	PC50 Intelligent Field Device Tool (Operation Using FoxCom Protocol)
PL 008-659	Parts List - RTT20 I/A Series Temperature Transmitter
DP 020-460	Dimensional Print - I/A Series Temperature Transmitter



# Standard Specifications

## Operating Conditions

*Table 2. Operating Conditions*

Influence	Reference Operating Conditions	Normal Operating Conditions
Ambient Conditions		
Without Integral Display	24 ±2°C (75 ±3°F)	-40 to +85°C (-40 to +185°F)
With Integral Display	24 ±2°C (75 ±3°F)	-29 to +70°C (-20 to +158°F)
Relative Humidity	50 ±10%	0 to 100% (noncondensing)
Supply Voltage	30 ±0.5 V dc	12 to 42 V dc
Vibration	0 m/s <sup>2</sup> (0 g)	30 m/s <sup>2</sup> (3 g) maximum(a)

(a) Limited to 10 m/s<sup>2</sup> (1 g) maximum with 316 ss housing.

## Functional Specifications

<b>Input Types and Range Limits</b>	See Table 4.
<b>Span Limits</b>	Minimum: 5°C (10°F). Maximum: See Table 4.
<b>Output Types</b>	4 to 20 mA. 4 to 20 mA with HART communication. 4 to 20 mA or FoxCom digital communication.
<b>Two-Wire Transmitter</b>	The same two wires are used for input power, output signal, and remote communication.
<b>Input Response Time</b>	With minimum damping, the 90% response time for an 80% input step is 1.2 seconds.
<b>Electronic Damping</b>	<u>4 to 20 mA Version</u> : 1.2 seconds. <u>HART Version</u> : Damping is set as a floating decimal point value between 0 and 32 seconds. <u>FoxCom Version</u> : Damping is configurable to settings of 0.00, 0.25, 0.50, 1, 2, 4, 8, 16, and 32 seconds.
<b>Turn On Time</b>	Two-wire Sensor: 3.5 seconds. Three- and Four-wire Sensors: 7 seconds.
<b>Minimum Power Supply Current</b>	35 mA
<b>Output</b>	Ranging: Zero and span adjustment are non-interacting. Underrange Current: 3.8 mA. Overrange Current: 20.75 mA. Failsafe (User-Configurable for Output Code -D and -T): 4 to 20 mA Version: Upscale/Downscale ON/OFF HART and FoxCom Versions: Downscale: 3.6 to 3.8 mA. Upscale: 20.75 to 23.0 mA. Action: Direct or Reverse.
<b>Output Update Rate</b>	4 to 20 mA: 6 times per second (all output versions). HART Digital: 2 times per second. FoxCom Digital: 10 times per second.
<b>Electromagnetic Compatibility (EMC)</b>	The RTT20 complies with the requirements of the European EMC Directive 89/336/EEC.
<b>Isolation</b>	500 V ac, rms.
<b>Input Impedance (mV Input Mode)</b>	>10 MΩ

**RFI Protection**

Susceptibility radiated

- In metal housing:
  - 30 V/m peak; 26-1000 mHz
  - 50% AM @ 11 kHz
  - 30 V/m peak; 900 MHz;
  - 50% duty cycle; 200 Hz rep.rate
- Basic Transmission:
  - 20 V/m peak; 26-1000 mHz
  - 50% AM @ 11 kHz
  - 20 V/m peak; 900 MHz;
  - 50% duty cycle; 200 Hz rep.rate

**Supply Voltage Requirements and External Loop Load Limitations**

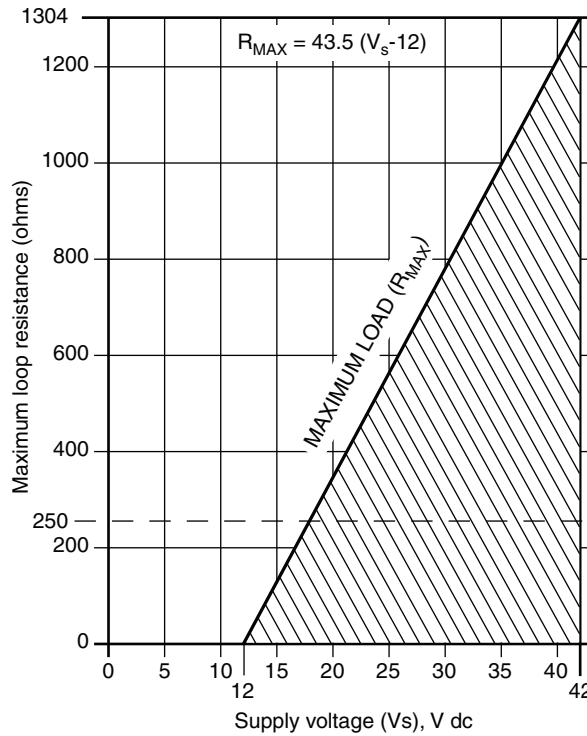

NOTES:

1. MINIMUM LOAD WITH HART COMMUNICATOR OR PC-BASED CONFIGURATOR CONNECTED IS 250 Ω
2. CONNECTING A PC-BASED CONFIGURATOR OR HART COMMUNICATOR WHILE OPERATING BELOW THE MINIMUM SPECIFIED LOAD MAY CAUSE COMMUNICATION PROBLEMS.

*Table 3. Input Types***Single Sensor**

Sensor Type	Conventional Output Code -I	FoxCom Output Code -D	HART Output Code -T
T/C Type B, C, E, J, K, L, N, R, S, T, U	Yes	Yes	Yes
RTD (2-, 3-, or 4-wire) 100 ohm DIN or SAMA	Yes	Yes	Yes
RTD 2-, 3-, or 4-wire) 100, 120, or 200 ohm Nickel	No	Yes	Yes
RTD (2-, 3-, or 4-wire) 10 ohm copper	No	Yes	Yes
Millivolt	Yes	Yes	Yes
Ohms (2-, 3-, or 4-wire)	Yes	Yes	Yes
Dewpoint	No	Yes	Yes
2 to 22 Point Custom Curve	No	Yes	Yes

**Dual Sensors**

Sensor Type RTD (2-wire only) DIN or SAMA	Conventional Output Code -I	FoxCom Output Code -D	HART Output Code -T
Redundant	No	No	No
Difference	No	Yes	Yes
Average	No	Yes	Yes
Independent (with digital output only)	No	Yes	Yes

Table 4. Range Limits, Maximum Span, and Accuracy <sup>(a)</sup>

Input Type	Model Code Letter	See Note	Range Limits		Maximum Span		± Digital Accuracy (b)(p)	
			°C	°F	°C	°F	°C	°F
<b>RTD (2, 3, or 4 wire)</b>								
Pt100 DIN/IEC	Q	c	-200 and +850	-328 and +1562	1050	1890	0.05	0.09
Pt100 DIN/IEC	A	d	-200 and +850	-328 and +1562	1050	1890	0.05	0.09
Pt100 SAMA	P	e	-200 and +650	-328 and +1202	850	1530	0.05	0.09
Ni 200	D	f,n	-130 and +315	-202 and +599	445	801	0.44	0.79
Ni 120, Minco	G	n	-80 and +320	-112 and +608	400	720	0.03	0.05
Ni 100	I	g,n	-60 and +250	-76 and +482	310	558	0.04	0.07
Cu 10	F	h,n	-70 and +150	-94 and +302	220	396	0.51	0.92
<b>Thermocouple</b>								
Type B	B	k,r	0 and +1820	+32 and +3308	1820	3276	0.51	0.92
Type C	C	k,p	0 and +2320	+32 and +4208	2320	4176	0.38	0.68
Type E	E	k	-270 and +1000	-454 and +1832	1270	2286	0.08	0.14
Type J	J	k	-210 and +1200	-346 and +2129	1410	2538	0.11	0.20
Type K	K	k	-270 and +1372	-454 and -2502	1642	2956	0.14	0.25
Type L	L	m	-200 and +900	-328 and +1652	1100	1980	0.13	0.23
Type N	N	k	-270 and +1300	-454 and +2372	1570	2862	0.15	0.27
Type R	R	k	-50 and +1768	-58 and +3214	1818	3272	0.42	0.76
Type S	S	k	-50 and +1768	-58 and +3214	1818	3272	0.49	0.88
Type T	T	k	-270 and +400	-454 and +752	670	1206	0.10	0.18
Type U	U	m	-200 and +600	-328 and -1112	800	1440	0.09	0.16
<b>Other</b>								
Millivolt	M		-15 and +115 mV dc		130 mV dc		6 μV	
Resistance	O		1 and 500 Ω		500 Ω		20 mΩ	
Dew Point	W	n	-45 and +96°C (-50 and +205°F)		142°C (255°F)		0.05°C (0.09°F)	
Custom	Z	n	2 to 22-point user-configurable curve					

(a) For 4 to 20 mA output accuracy, add ±0.05% to digital accuracy.

(b) Digital accuracy is either the listed value or ±0.01% of span, whichever is greater. For thermocouples only, add the applicable cold junction error to digital accuracy:

Integral: ±0.2°C (±0.5°F).

Remote: Depends on accuracy of remote sensor.

(c) IEC/DIN 751; alpha = 0.00385 (1984) ASTM-B Standard Accuracy.

(d) IEC/DIN 751; alpha = 0.00385 (1984) ASTM-A High Accuracy.

(e) SAMA Standard RC 21-4; alpha = 0.003923.

(f) Foxboro NR 226/227. Refer to TI 005-24a.

(g) DIN 43760.

(h) Foxboro CR 228/229. Refer to TI 005-24a.

(k) NIST Monogram 125, DIN IEC 584.

(m) DIN 43710 (1985).

(n) Not accessible with optional LCD Indicator/Configurator.

(p) Tungsten 5% Rhenium-Tungsten 26%.

(q) Does not include sensor accuracy.

(r) May exhibit a decrease in performance at temperatures below 43°C (109°F).

## Physical Specifications

<b>Basic Transmitter</b>	Polycarbonate with molded ryton terminal block. Screw terminals of nickel over copper-plated steel.																		
<b>Mounting Options</b>	<table border="1"> <thead> <tr> <th>Option</th> <th>Code</th> <th>Bracket</th> <th>Hardware</th> </tr> </thead> <tbody> <tr> <td>Mounting Set</td> <td>-M1</td> <td>Epoxy-Coated Steel</td> <td>Plated Steel</td> </tr> <tr> <td>Stainless Steel Mounting Set</td> <td>-M2</td> <td>Stainless Steel</td> <td>Stainless Steel</td> </tr> <tr> <td>DIN Rail Hardware</td> <td>-D1</td> <td>Aluminum and Plastic</td> <td>Plated Steel</td> </tr> </tbody> </table>	Option	Code	Bracket	Hardware	Mounting Set	-M1	Epoxy-Coated Steel	Plated Steel	Stainless Steel Mounting Set	-M2	Stainless Steel	Stainless Steel	DIN Rail Hardware	-D1	Aluminum and Plastic	Plated Steel		
Option	Code	Bracket	Hardware																
Mounting Set	-M1	Epoxy-Coated Steel	Plated Steel																
Stainless Steel Mounting Set	-M2	Stainless Steel	Stainless Steel																
DIN Rail Hardware	-D1	Aluminum and Plastic	Plated Steel																
<b>Enclosure Construction</b>	Housing: Epoxy-coated, low-copper aluminum or 316 ss. Union coupling (thermowell only): zinc plated steel or 316 ss.																		
<b>Environmental Protection</b>	Housing: NEMA 4X, IP66.																		
<b>Approximate Mass</b>	Basic Transmitter Package: 0.13 kg (0.28 lb). Aluminum Pipe or Surface Mount Housing: 1.47 kg (3.25 lb). 316 ss Pipe or Surface Mount Housing: 3.25 kg (7.25 lb). 3-Line Indicator: Add 0.06 kg (0.13 lb).																		
<b>Housing Connections (2)</b>	1/2 NPT (see note below)																		

---

### — NOTE —

Housings with optional PG 13.5 connections are available except in transmitters that are certified for explosionproof/flameproof installations.

---

## Electrical Certification Rating

The electrical certification is printed on the agency label which is located on the basic module and on the transmitter housing (if applicable). The Electrical Safety Design Code is also included as part of the model code on the data plate which is located on the basic module or on the transmitter housing (if applicable). See Figure 1 for an example of a typical data plate. For a complete explanation of the model code, see PL 008-659.

---

### — DANGER —

To prevent possible explosions and to maintain explosionproof, dust-ignitionproof protection, observe applicable wiring practices. Plug any unused conduit opening with a metal pipe plug, which engages a minimum of five full threads.

---



---

### — WARNING —

To maintain IEC IP66 and NEMA Type 4X protection, any unused conduit opening must be plugged with a metal plug. In addition, the threaded housing cover must be installed. Hand tighten cover as much as possible so that the O-ring is fully captured.

---

# Electrical Safety Specifications

---

**— NOTE —**

---

These transmitters have been designed to meet the electrical safety description listed in Table 5. For detailed information or status of agency approvals/certifications, contact Invensys Foxboro.

---

*Table 5. Electrical Safety Specifications*

Agency Certification, Type of Protection, and Area Classification	With Package Config. Codes	Application Conditions	Electrical Safety Design Code
CENELEC (KEMA) intrinsically safe EEx ia, IIC, Zone 0.	All	KEMA No. Ex-95.D4252X Temperature Class T4 - T6.	EA
CENELEC (KEMA) Nonsparking/nonincendive, Ex N IIC	All	KEMA No. Ex-95.Y.4253X Temperature Class T4 - T6.	KN
ATEX (FM) flameproof, II 1/2 G, Ex d, IIC.	S, T, L, M	FM06ATEX0002 Temperature Class T6. Ta = -40 to +70°C	ED
ATEX (FM) flameproof, II 2 G, Ex d, IIC.	W, Y	FM06ATEX0002 Temperature Class T6. Ta = -40 to +70°C	
ATEX (FM) flameproof, II 2 D.	S, T, L, M, W, Y	FM06ATEX0002 T85°C, Ta = 70°C max. ambient	
CSA intrinsically safe, Class I, Division 1, Groups A, B, C, and D.	B	Temperature Class T4 at 85°C and T6 at 40°C maximum ambient. Connect per MI 020-454.	CA
CSA intrinsically safe, Class I, Division 1, Groups A, B, C, and D; dust- ignitionproof, Class II, Division 1, Groups E, F, and G; Class III, Division 1.	S, T, L, M, W, Y	Temperature Class T4 at 85°C and T6 at 40°C maximum ambient. Connect per MI 020-454.	
CSA Class I, Division 2, Groups A, B, C, and D.		Temperature Class T4 at 85°C and T6 at 40°C maximum ambient.	
CSA Explosionproof, Class I, Division 1, Groups B, C, and D; dust-ignitionproof, Class II, Division 1, Groups E, F, and G; and Class III, Division 1.	S, T, L, M, W, Y	Connect to source not exceeding 42 V. Temperature Class T4 at 85°C and T6 at 40°C maximum ambient.	CD <sup>(a)</sup>
CSA Class I, Division 2, Groups A, B, C, and D.		Temperature Class T4 at 85°C and T6 at 40°C maximum ambient.	
CSA Class I, Division 2, Groups A, B, C, and D.	All	Temperature Class T4 at 85°C and T6 at 40°C maximum ambient.	CN

Table 5. Electrical Safety Specifications (Continued)

Agency Certification, Type of Protection, and Area Classification	With Package Config. Codes	Application Conditions	Electrical Safety Design Code
FM intrinsically safe, Class I, Division 1, Groups A, B, C, and D.	B	Temperature Class T6; T4 at 85°C maximum ambient. Connect per MI 020-454.	FA
FM intrinsically safe, Class I, Division 1, Groups A, B, C, and D; dust-ignitionproof, Class II, Division 1, Groups E, F, and G; Class III, Division 1.	S, T, L, M, W, Y	Temperature Class T6; T4 at 85°C maximum ambient. Connect per MI 020-454.	
FM nonincendive, Class I, Division 2, Groups A, B, C, and D; Class II, Division 2, Groups F and G; Class III, Division 2.		Temperature Class T4 at 85°C and T6 at 40°C maximum ambient.	
FM Explosionproof, Class I, Division 1, Groups B, C, and D; dust-ignitionproof, Class II, Division 1, Groups E, F, and G; and Class III, Division 1.	S, T, L, M, W, Y	Temperature Class T4 at 85°C and T6 at 40°C maximum ambient.	FD <sup>(a)</sup>
FM nonincendive, Class I, Division 2, Groups A, B, C, and D; Class II, Division 2, Groups F and G; Class III, Division 2.		Temperature Class T4 at 85°C and T6 at 40°C maximum ambient.	
FM nonincendive, Class I, Division 2, Groups A, B, C, and D.	B	Temperature Class T4 at 85°C and T6 at 40°C maximum ambient.	FN
FM nonincendive, Class I, Division 2, Groups A, B, C, and D; Class II, Division 2, Groups F and G; Class III, Division 2.	L, M, S, T, W, Y	Temperature Class T4 at 85°C and T6 at 40°C maximum ambient.	
IECEx flameproof, Ex d IIC	L, M, S, T, W, Y	IECEx FMG07.0001X Temperature Class T6. Ta = 70°C	VV

(a) FM approval and CSA certification of the Model RTT20 for the explosionproof rating listed above included pressure piling tests with various lengths of conduit to ensure that conduit seals per NEC 501-5(a)1 within 457 mm (18 inches) of the housing are **not** required.

## ATEX Warning

—  **WARNING** —

Do not open while energized.

## IECEx Warning

—  **WARNING** —

Do not open when energized or when an explosive atmosphere may be present.



## FM and CSA Warnings

---

**! WARNING**  
Explosion Hazard - Do not disconnect equipment unless power has been switched off or the area is known to be nonhazardous.

---

For Intrinsic Safety Certifications:

---

**! WARNING**  
Substitution of components may impair intrinsic safety.

---

For Explosionproof Certifications:

---

**! WARNING**  
Keep cover tight while circuits are alive.

---

## ATEX Compliance Documents

Directive 94/9/EC - Equipment or Protective Systems Intended for Use in Potentially Explosive Atmospheres.

Also, compliance with the essential health and safety requirements has been assured by compliance with the following documents as stated in the compliance certificate:

FM06ATEX0002

EN 60079-0:2004; EN 60079-1:2004; EN50281-1-1:1998 + A1:2002;  
EN 60079-26: 2004; EN 60529:1991 + A1: 2000.

## CENELEC Compliance Documents

KEMA No. Ex-95.D.4252X

EN 50014: 1977 = A1...A5 General Requirements  
EN 50020: 1977 = A1...A5 Intrinsic Safety

KEMA No. Ex-95.Y.4253X

BS 6941:1988, Electrical apparatus for explosive atmospheres with type of protection N.

## IECEx Compliance Documents

IEC 60079-0 (Fourth Edition):2004  
IEC 60079-1 (Fifth Edition):2003



## 2. Installation

The following material provides information and procedures for installing the RTT20 Transmitter. For dimensional information, refer to DP 020-460.

---

— **NOTE** —

Use a suitable thread sealant on all connections.

---

---

— **!** **CAUTION** —

Bare sensor or thermowell mounting to the 316 ss housing should not be used in high vibration areas.

---

### Unpacking

Upon receipt, inspect the package for any sign of damage that may have occurred in shipping. Immediately report any shipping damage to the shipping agent/carrier. The carrier may not honor any claims unless all shipping material is retained for examination. After examining the packaging and removing the contents, save the carton and packaging material in the event the transmitter needs to be returned for any reason.

### Transmitter Mounting

The basic transmitter can be mounted on a DIN rail or to a flat surface. The transmitter in a field housing can be pipe mounted, surface mounted, mounted directly to a bare sensor, or thermowell mounted. See Figures 2 through 6. For extremely high process temperatures, a remote mounted sensor is recommended. Also, the mounting stability can influence how the sensor is attached to the transmitter. If the process vessel is highly insulated and the thermowell has considerable lagging, a remote mounted transmitter attached to a 50 mm (2 inch) pipe is recommended. When mounting the transmitter, take into account the necessary room to remove the cover if you wish to use the indicators or remote configurators at the transmitter. The housing can be mounted in any position. The module can be rotated in 90 degree increments to align the optional indicator for easy viewing.

#### DIN Rail Mount

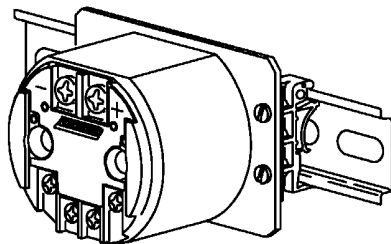

*Figure 2. DIN Rail Mount*

## Pipe or Surface Mount

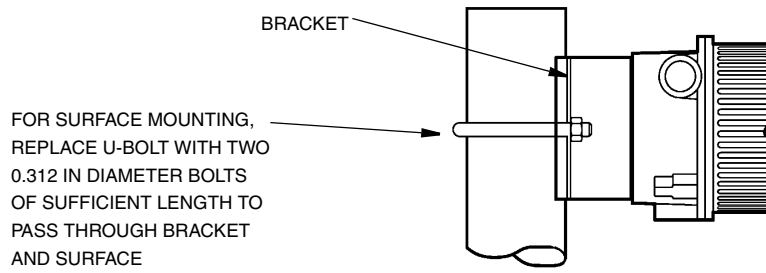

*Figure 3. Pipe or Surface Mount*

## Surface Mount without Bracket

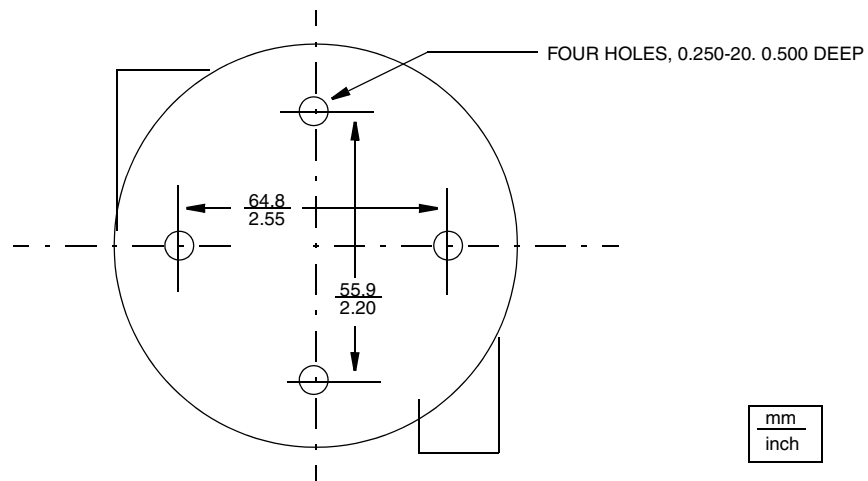

*Figure 4. Surface Mount without Bracket (Rear View)*

## Bare Sensor Mount

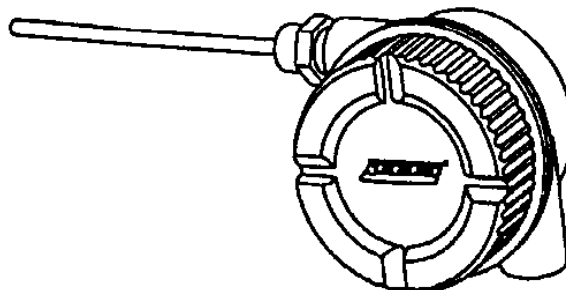

*Figure 5. Bare Sensor Mount*

## Thermowell Mount

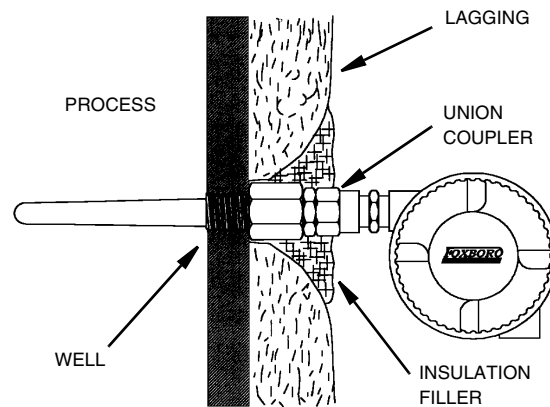

*Figure 6. Thermowell Mount*

## Mounting Basic Transmitter in Old Style Housing

The RTT20 can be used as a replacement for existing E93, E94, 893, and RTT10 temperature transmitters. When replacing the old style transmitter with a new RTT20 module, any RTT20 can be used if the label on the outside of the housing shows an explosionproof electrical code. If the electrical code information on the data plate is any European agency (CENELEC, BASEEFA, KEMA, etc.) or any other intrinsically safe agency approval (FM or CSA), the RTT20 module must be labeled for intrinsic safety.

In addition, for intrinsically safe agency approval, the existing barrier must be suitable for the entity parameters of the RTT20 module as listed in MI 020-454 for FM and CSA or the certificate for CENELEC. Also for instruments that were intrinsically safe approved, the agency plate on the outside of the housing should be removed as it is no longer valid. Refer to parts list for applicable part numbers.

The transmitter can be mounted in the old housing by replacing the existing mounting plate with a new one supplied when a –D3 option is specified or by drilling two holes in the existing mounting plate. Replace the existing mounting plate as follows:

1. Remove the housing cover of your existing transmitter.
2. Remove the transmitter and mounting plate from the housing.
3. Install the new mounting plate using the four screws that fastened the old mounting plate.
4. Fasten the RTT20 Transmitter to the new mounting plate with two screws provided.

To drill your existing mounting plate, locate the holes per Figure 7.

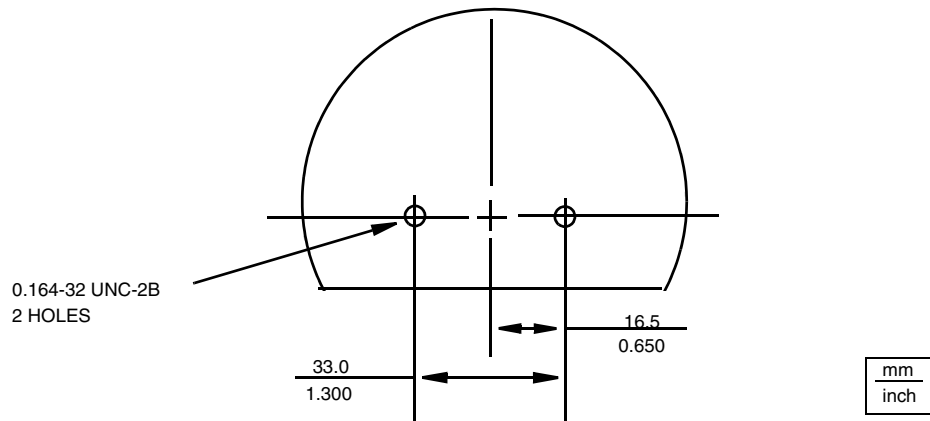

Figure 7. Locating New Holes in Existing Mounting Plate

## Positioning Transmitter to View Optional Indicator

The transmitter module can be rotated in 90° increments to align the indicator for easy viewing. To do this, loosen the two mounting screws, rotate the transmitter module, and retighten the mounting screws.

**CAUTION**  
Do not overtighten the mounting screws.

## Cover Lock

A housing cover lock is provided as standard with certain agency certifications and as part of the Custody Transfer Lock and Seal option.

To lock the cover on the housing, screw the cover onto the housing as far as possible, place the clamp as shown below and tighten the clamp screw. Insert the seal wire through the clamp and crimp the seal if applicable.

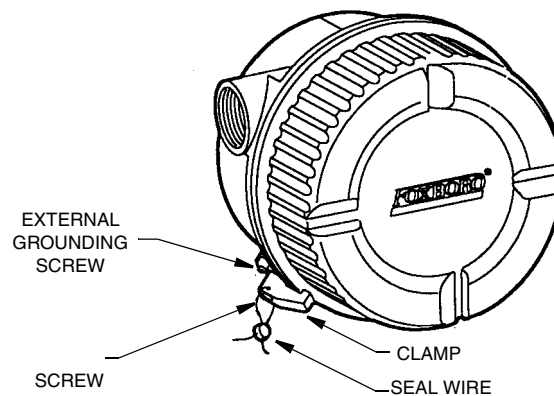

Figure 8. Cover Lock

## Transmitter Wiring

Your transmitter must be installed to meet all local installation regulations, such as hazardous location requirements and electrical wiring codes. Persons involved in the installation must be trained in these code requirements. To maintain agency certification, your transmitter must also be installed in accordance with the agency requirements.

---

— **⚠ WARNING** —

On transmitters with Housing Code L, M, S, T, W, and Y, to maintain IEC IP66 and NEMA Type 4X protection, any unused conduit opening must be plugged with a metal plug. In addition, the threaded housing cover must be installed. Hand tighten cover as much as possible so that the O-ring is fully captured.

---



---

— **NOTE** —

Foxboro recommends the use of transient/surge protection in installations prone to high levels of electrical transients and surges.

---

## Power Supply Requirements for HART Transmitters

There are specifications for the power supply to be used to energize a HART loop. They are as follows:

Voltage	24 V dc typical
Maximum ripple (47 to 125 Hz)	0.2 V p-p
Maximum noise (500 Hz to 10 kHz)	1.2 mV rms
Maximum series impedance (500 Hz to 10 kHz)	10 $\Omega$

The ripple and noise specifications prevent direct interference with the HART signals. The impedance limit ensures that HART signals recognize the power supply as a low impedance path, and prevents inadvertent coupling of multiple HART loops when powered from a common power supply. (The resistance of output fuses, if any, must be included when measuring this value.) The power supply voltage limits are determined by the instruments in the loop, and not by requirements of HART protocol.

## Conduit Drainage

The transmitter is completely sealed to resist moisture. However, improper routing of conduit for the power or sensor wires can allow moisture to collect inside the housing and provide conductivity paths between the various screw terminals. This can cause errors until the housing is dried out.

Therefore it is preferable to run conduit below the transmitter as shown in Figure 9. If you must run conduit above the transmitter, a conduit seal at the housing is advisable.

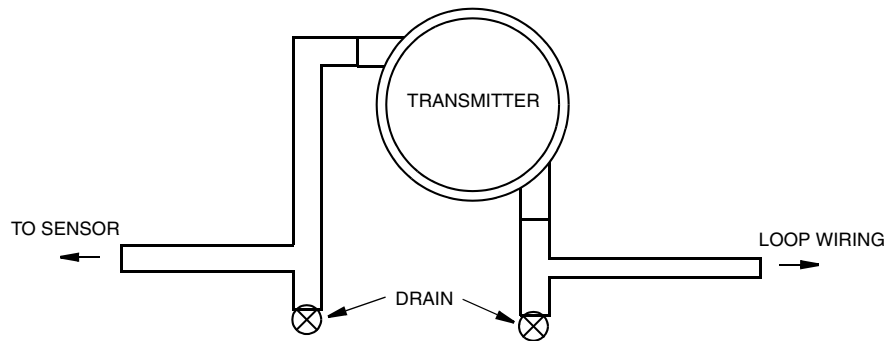

*Figure 9. Recommended Conduit Routing*

In extremely humid environments where the conduit cannot be installed with recommended conduit drains as shown in Figure 9, Invensys Foxboro recommends installing a poured conduit seal at the conduit entries of the housing. This will eliminate the conduit moisture from entering the housing. Make sure to use a silicone sealing compound at all threaded connections between the poured seal and the transmitter housing.

One manufacturer of poured conduit seals is Cooper Industries, Crouse-Hinds Division (Phone 315-477-7000 in U.S.A.).

Description	Part Number
Connection for 1/2 inch conduit thread	EYS 116
Sealing Compound	CHICO A3
Fiber Fill	CHICO X4

## Hazardous Locations

### *General*

When using the RTT20 transmitter in a hazardous location, care must be taken to ensure proper installation practices per the applicable agency requirements. The housing was designed for explosionproof installations. In addition, the basic transmitter is available for intrinsically safe and nonincendive operation. Each transmitter and housing has a label indicating the hazardous location approvals. To maintain the certified rating, the transmitter must be installed per the applicable code requirements.

#### **⚠ WARNING**

The following information can only be considered as general information and the user is responsible for proper installation in hazardous areas per the applicable agency codes and guidelines.



## *Conduit Seals in Hazardous Locations*

When installing the transmitter as explosionproof in a Division 1 area, the National Electrical Code requires conduit seals at the boundary between the hazardous divisions. Therefore, when the conduit is routed from a Division 1 to a Division 2 area, there must be a conduit seal with a minimum of five full threads engaged. There also must be a conduit seal when the conduit is routed out of a Division 1 or Division 2 area into a nonhazardous location.

In addition to the conduit seals at the hazardous division boundaries, section 501-5(a)(1) of the NEC code requires that for Class I, Division 1 explosionproof locations, a conduit seal must be installed within 18 inches (457 mm) of a device that “may produce arcs, sparks, or high temperatures” to eliminate pressure piling. Pressure piling is the result of a flame traveling down the conduit run, thereby pressurizing the explosionproof housing.

---

— **NOTE** —

Sources of ignition are not present in the RTT20 transmitter. Also, Factory Mutual (FM) has tested the housing with various lengths of conduit to simulate the pressure piling effect. Therefore, per NEC 501-5(a)(1), conduit seals are **not** required within 18 inches (457 mm) of the housing.

---

## *Process Seals in Hazardous Locations*

The National Electrical Code NEC 501-5(f)(3) requires a secondary seal to eliminate the possibility of process fluid entering the control room if the primary process seal should fail. Foxboro-supplied integrally mounted sensors (bare or thermowell mount) are attached to the single compartment housing without a secondary seal. Therefore, in hazardous locations, if the integrally mounted bare sensor were to fail, or the thermowell failed, there could be a direct path for the process fluid to enter the control room through the transmitter housing and conduit. A process seal of this type is very difficult to install in the field conduit. Also, the poured or molded “conduit seals” to prevent pressure piling are only required to withstand 6 inH<sub>2</sub>O differential pressure. Therefore, a “conduit seal” is not an acceptable “process seal” to comply with section 501-5(f)(3). In these applications, Foxboro recommends that the sensor should be remotely mounted from the transmitter housing.

## Sensor Connections and Wiring

### Single RTD or Ohm Applications.

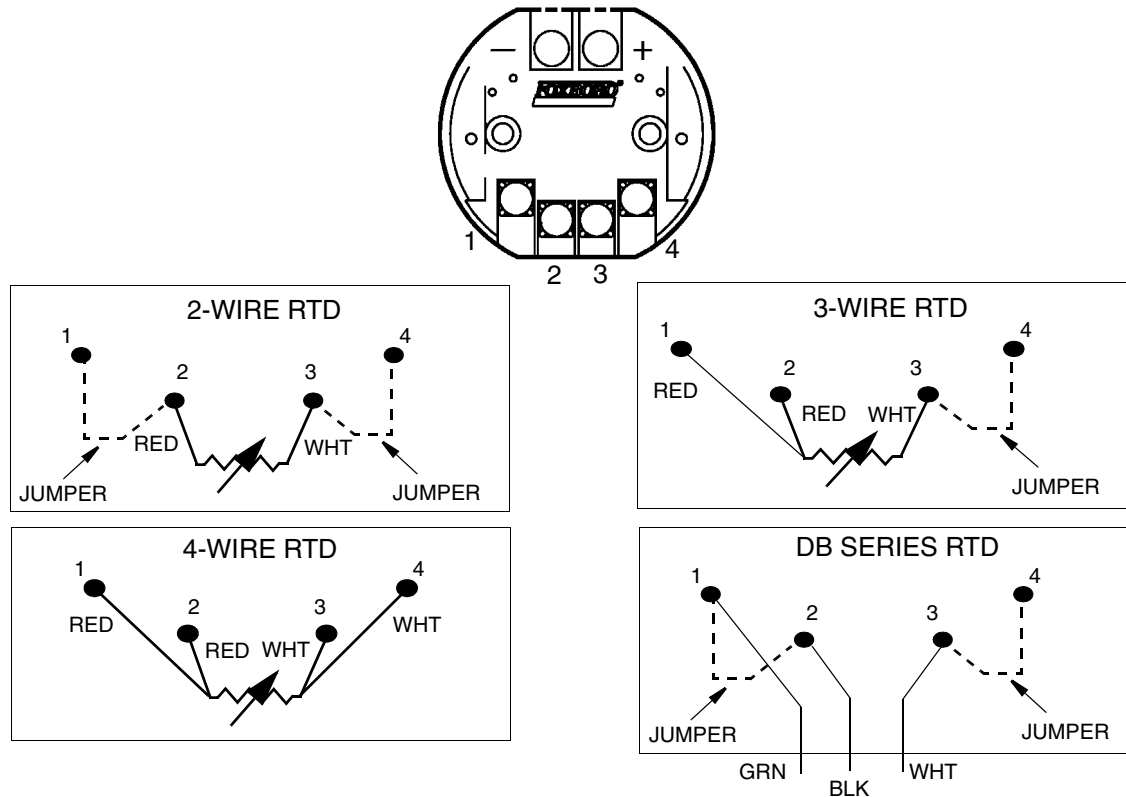

Figure 10. Single RTD Wiring

Three and four wire RTDs are compensated up to  $40 \Omega$  for each lead. This is approximately equal to 1220 m (4000 ft) of 20 gauge wire. The total resistance including the RTD and the two lead wires is:

$$\frac{180 \text{ mV}}{0.3 \text{ mA}} = \frac{0.180 \text{ V}}{0.0003 \text{ A}} = 600 \Omega$$

Therefore, if a platinum RTD is used to measure a maximum temperature of  $1292^\circ\text{F}$  ( $700^\circ\text{C}$ ), the RTD resistance is  $345 \Omega$  and the maximum permissible lead wire resistance (for both leads combined) is:

$$600 \Omega - 345 \Omega = 255 \Omega$$

You may calculate the maximum permissible lead wire resistance for other RTD applications in a similar manner.

For a single 2-wire RTD, the extension leads are in series with the sensing portion of the RTD, so lead length should be minimized. If the distance between the transmitter and sensor is “long”, change the RTD to a 3- or 4-wire RTD.

The “lead length” errors associated with two-wire RTDs are:

- ◆ Positive offset due to lead wire resistance

- ◆ Change in lead wire resistance due to ambient temperature changes is added to or subtracted from the sensor reading

For example, consider a transmitter calibrated 32 to 212 °F with a 2-wire DIN RTD and 500 feet of 20 gauge wire between the sensor and transmitter. The extension wire will offset the curve by +48 °F (27% error). Of course, this error can be eliminated by using a one-point calibration or a 2-point custom curve, using 80 to 260 °F due to the 48 °F offset. Also, as the ambient temperature changes 50 °F, the resistance change of the extension wire will create an additional  $\pm 3\%$  zero shift, which cannot be eliminated. These lead length and ambient temperature errors are virtually eliminated with a 3- or 4-wire RTD.

## Dual RTD Applications

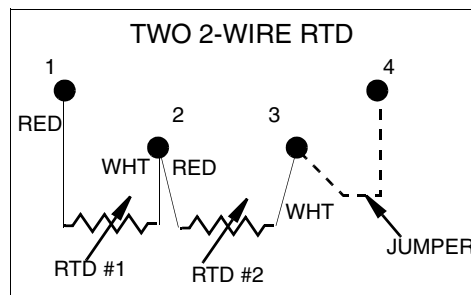

Figure 11. Dual RTD Wiring

For dual RTD measurements (not available with convention Output Code -I), the RTDs can only be 2-wire. The RTT20 cannot have dual 3- or 4-wire RTDs. Also, the 2-wire RTDs must be the same type and the extension lead resistance will be added to the RTD measurement, creating an error. Foxboro recommends that for dual measurements the extension wires be held to an absolute minimum to avoid errors.

The local 1-line and 3-line indicators do not have the ability to configure the transmitter for dual RTDs (remote configurator must be used). The dual RTD choices are:

- ◆ Difference
- ◆ Average
- ◆ Independent (HART version only)

### — CAUTION —

After sales release of the product, Foxboro discovered that the Redundant operation does not work properly. If RTD #1 fails, the output will switch automatically to RTD #2, only if RTD #1 fails shorted. If RTD #1 fails open, the output goes to failsafe conditions. Therefore, Foxboro is removing this selection from the remote configurator software.

## RTD Extension Wiring

**Wire Material:** Nickel or tin-plated copper wire is recommended.

**Wire Gauge:** 18 to 24 AWG.

**Wire Type:** Stranded wire is recommended for improved termination under transmitter terminal screws.

**Shielding:** Shielded wire is recommended with the shield grounded at the transmitter case.

**—! CAUTION** \_\_\_\_\_  
 Do **not** ground the shielding at both the transmitter and the sensor under any circumstances.  
 \_\_\_\_\_

**Other Recommendations:**

- ◆ Do not run sensor extension wires in the same conduit as the 4 to 20 mA loop wires or power cable
- ◆ Twist wires together to improve noise resistance
- ◆ Make the extension wires the same length (without splices)
- ◆ Periodically check terminations at each end to ensure that terminal screws are tight and that no significant surface corrosion has developed.

The above items are recommendations, not absolute requirements. The primary issues, when using extension wire to connect a 4- or 4-wire RTD sensor to the RTT20 Transmitter are:

- ◆ To make a secure wire to terminal connection with minimal contact resistance
- ◆ To make the wires the same length with no added splices or interconnections between the sensor terminals and the transmitter
- ◆ To protect the wires from picking up environmental noise by using proper shielding.

*Thermocouple or Voltage Applications*

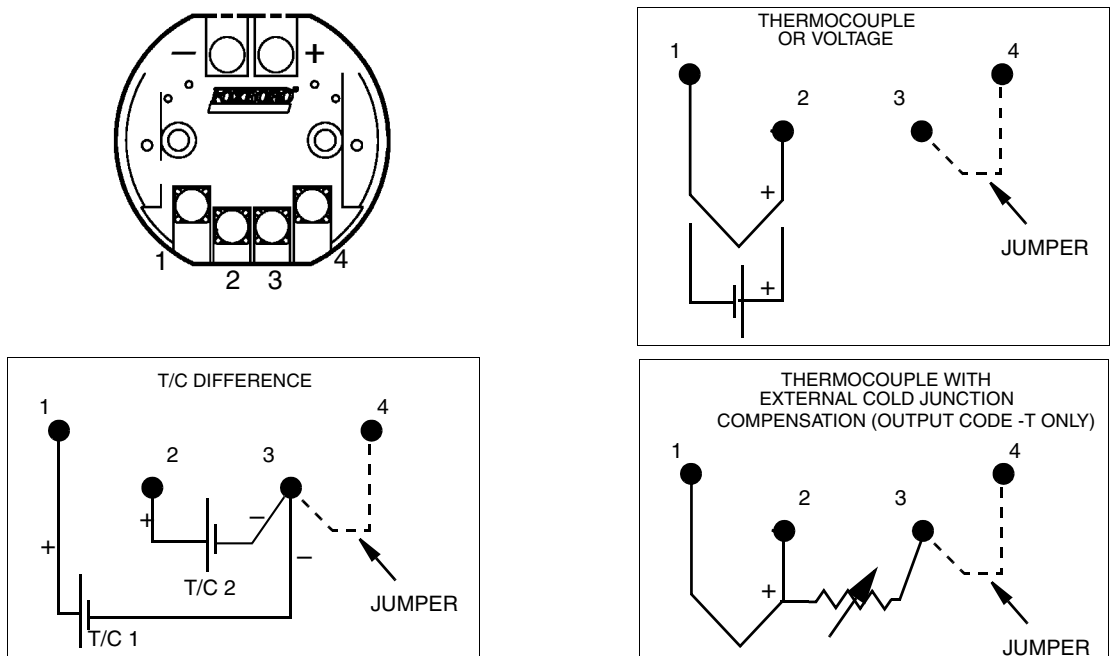

NOTE: TWIST NEGATIVE LEADS TOGETHER PRIOR TO ATTACHING TO TERMINAL

*Figure 12. Thermocouple or Voltage Wiring*

Thermocouple extension wire must be the same type as the thermocouple used. Foxboro recommends that extension wires should be twisted with an overall shield to avoid extraneous noise pickup. The shield should be grounded at the sensor.

## Loop Wiring

### *Wiring a Transmitter to an I/A Series System*

The RTT20 temperature transmitter can be wired to various Fieldbus Modules (FBMs) of an I/A Series System as follows:

#### **Conventional Output Code -I**

The 4 to 20 mA output of the transmitter can be connected to an analog FBM01, 04, 201, or 204 just like any other analog 4 to 20 mA output device. The Output Code -I transmitter does not include a modem, therefore, there will not be any bi-directional communications between the transmitter and the control system. Transmitter power is supplied through the FBM or from a remote power supply. Reconfiguration of the transmitter database can only be accomplished by using the integral Indicator/Configurator (option -L3).

#### **HART Output Code -T**

The transmitter can send its measurement to an I/A Series system as a digital signal via an FBM214/215. Transmitter power is supplied by the FBM. Wiring terminations at the transmitter are the same as described in “FoxCom Output Code -D” below. For other system wiring details, refer to the installation instructions provided with the I/A Series system.

#### **FoxCom Output Code -D**

Your transmitter, whether its output signal is configured **DIGITAL** or **4-20 mA**, has a digital output to communicate with an I/A Series system. If configured **DIGITAL**, connect to an FBM 18, 39, 43, 44, or 243. Its digital communications rate is 4800 baud. If configured **4-20 mA**, connect to an FBM 43, 44, or 243. Its digital communications rate is 600 baud.

---

#### **⚠ CAUTION**

1. All devices attached to an FBM 43 or FBM 44 must be configured for the same output (**DIGITAL** or **4-20 mA**).
  2. Make sure that Device Name parameter is configured the same as the letterbug used for that channel in the I/A Series system, or verify that it is set to its default description, **DevNam**, before installation.
- 

---

#### **— NOTE**

An I/A Series system can also receive an analog signal from a transmitter configured **4-20 mA** and attached to an FBM01, 04, 201, or 204. However, it cannot communicate digitally with the transmitter using this analog signal.

---

Transmitter power is supplied by the FBM. The maximum total resistance for each transmitter loop varies with the FBM. The maximum recommended length for field wire is 600 m (2000 ft). However, the maximum total resistance must be taken into consideration. For example, if the

maximum total loop resistance allowed is  $420\ \Omega$  and an intrinsically safe barrier with a resistance of  $200\ \Omega$  is used, the maximum resistance left for receivers in the loop and wire resistance is  $220\ \Omega$

1. Remove the cover from the transmitter housing.
2. Run signal wires (0.50 mm<sup>2</sup> or 20 AWG, typical) through one of the transmitter conduit connections as shown in Figure 13. Use twisted pair to protect the digital output and/or remote communications from electrical noise. Screened (shielded) cable may be required in some locations.

---

— **NOTE** —

---

Do not run transmitter wires in same conduit as mains (ac power) wires.

---

3. If shielded cable is used, earth (ground) the shield at the field enclosure **only**. Do not ground the shield at the transmitter.
4. Plug unused conduit connection with the metal plug provided (or equivalent). To maintain specified explosionproof and dust-ignitionproof protection, plug must engage a **minimum** of five full threads.
5. Connect the signal wires to the transmitter “+” and “-” terminal screws.
6. Reinstall the cover on the transmitter housing.
7. To connect the transmitter signal wires to the I/A Series system, refer to applicable I/A Series system instructions.

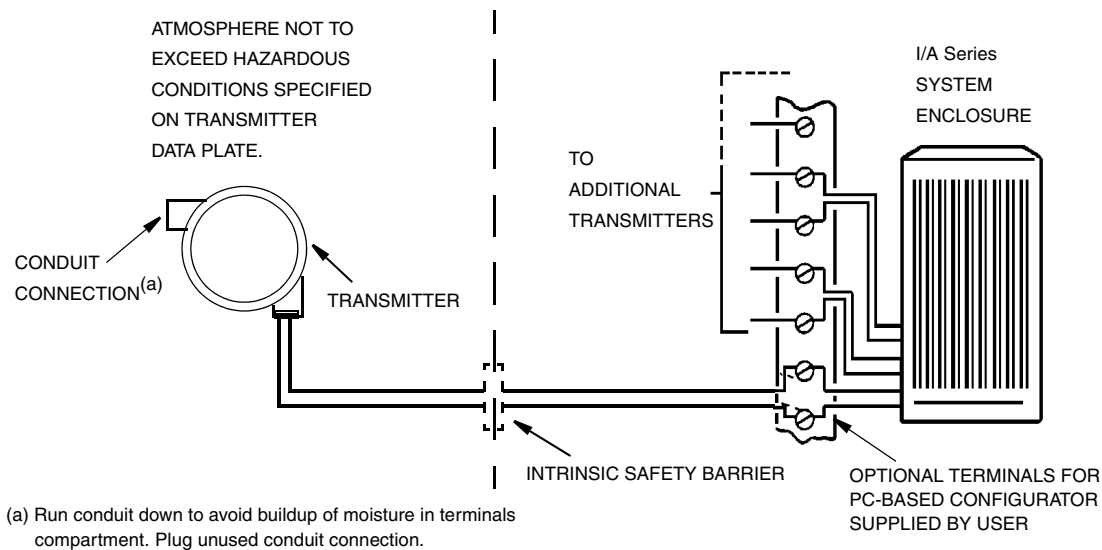

*Figure 13. Typical Transmitter Wiring to an I/A Series System*

### *Wiring a Transmitter Having a 4 to 20mA Output Signal*

When wiring a transmitter with 4 to 20 mA output signal, the supply voltage and loop load must be within specified limits. The supply voltage vs. output load relationship is shown in Figure 14. Any combination of supply voltage and loop load resistance in the shaded area can be used. To

determine the loop load resistance (transmitter output load), add the series resistance of each component in the loop, excluding the transmitter.

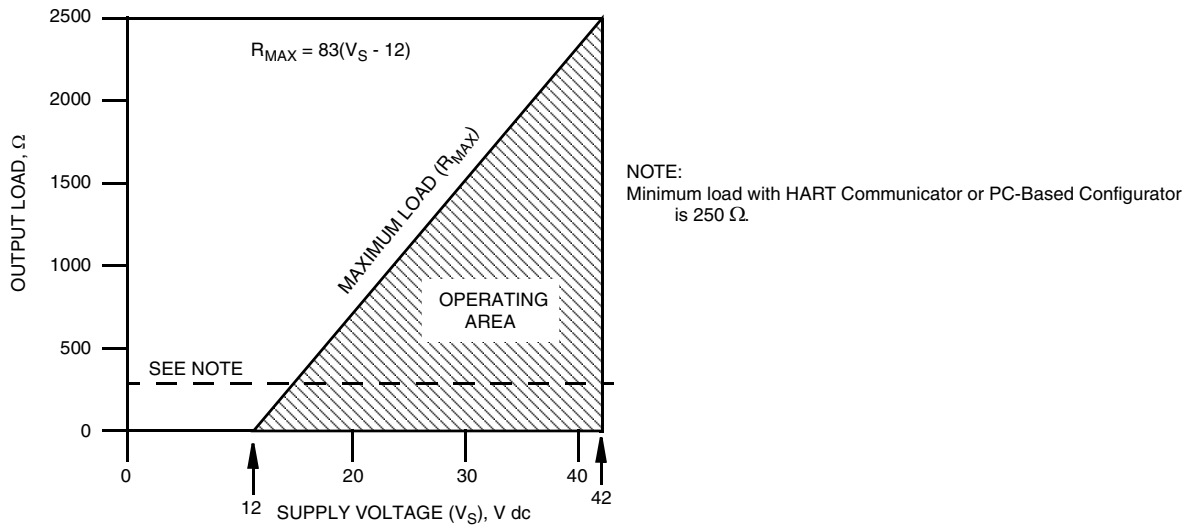

Figure 14. Voltage and Load Limits

The maximum output load resistance,  $R_{MAX}$ , is determined by the formula:

$$R_{MAX} = 83(V_S - 12)$$

— **⚠ CAUTION** —

Connecting a PC-Based Configurator, or HART Communicator while operating below the specified minimum load may cause output disturbances and/or communication problems.

Even though the transmitter has various filters to reduce or eliminate electrical noise, the power supply should have less than 2% ripple.

To wire one or more transmitters to a power supply, proceed with the following steps.

1. Remove the cover from the transmitter housing.
2. Run signal wires (0.50 mm<sup>2</sup> or 20 AWG, typical) through one of the transmitter conduit connections as shown in Figure 15. Use twisted pair to protect the 4 to 20 mA output and/or remote communications from electrical noise. Maximum recommended length for signal wires is 1800 m (6000 ft). Screened (shielded) cable may be required in some locations.

— **NOTE** —

Do not run transmitter wires in same conduit as mains (ac power) wires.

3. Connect the power supply and receiver loop wires to the transmitter “+” and “-” terminal screws.
4. Connect receivers (such as controllers, recorders, indicators) in series with power supply and transmitter as shown in Figure 15.
5. Reinstall the cover onto the transmitter housing.

6. If wiring additional transmitters to the same power supply, repeat Steps 1 through 5 for each additional transmitter. The setup with multiple transmitters connected to a single power supply is shown in Figure 16.
7. The remote configurator can be connected in the loop (subject to hazardous location restrictions) as shown in Figure 15 and Figure 16.

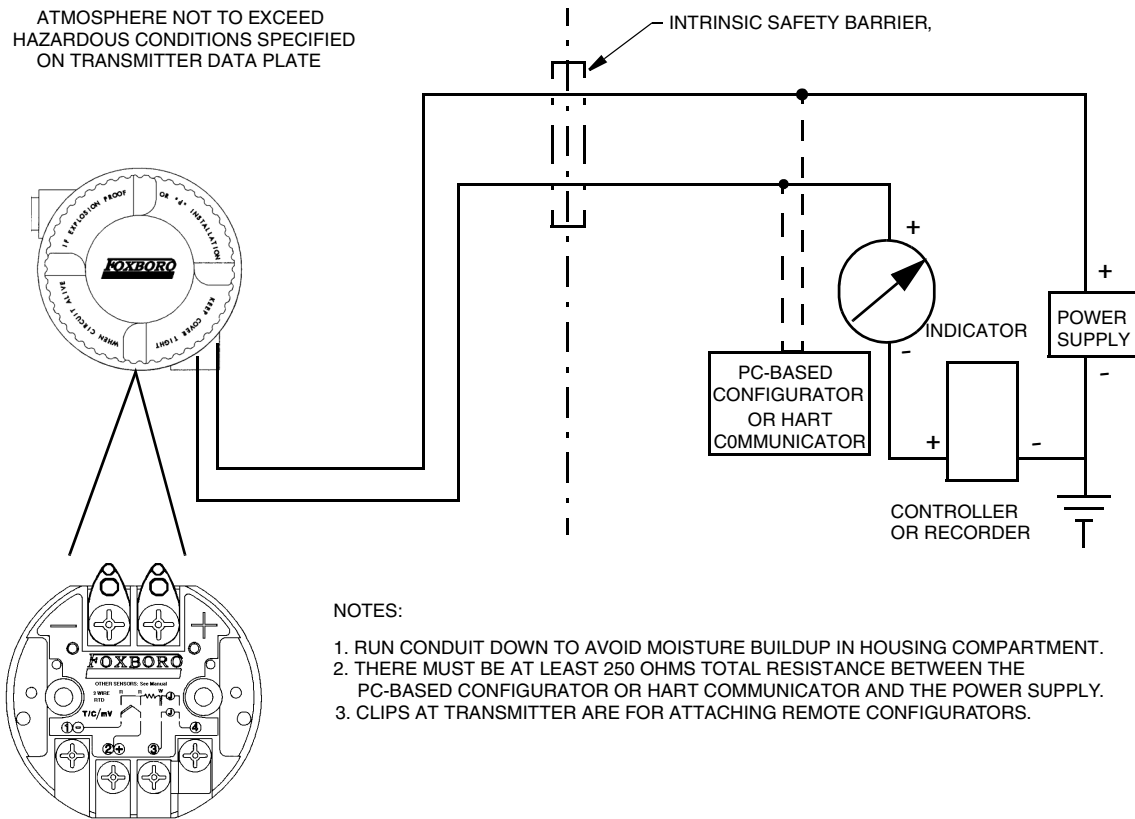
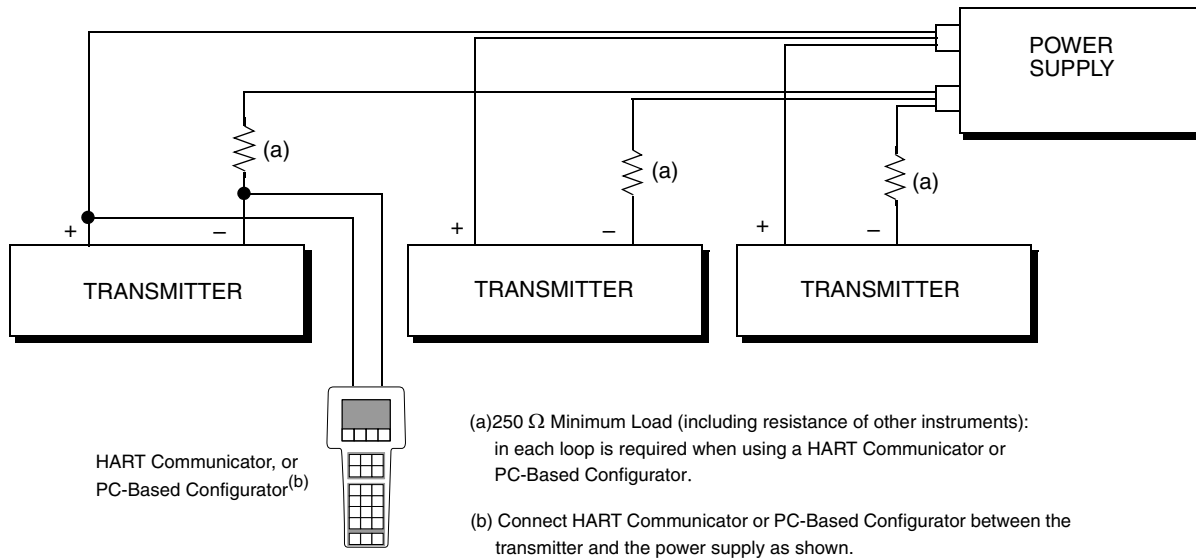

Figure 15. Typical Transmitter Wiring with a 4 to 20 mA Output





*Figure 16. Wiring Several 4 to 20 mA Transmitters to a Common Power Supply*

## Grounding (Earthing)

The transmitter will operate with the loop wiring floating or grounded. If the loop wiring is grounded, the preferred method is to ground the negative lead close to the power supply. Never ground the loop at more than one point.

The transmitter is an isolated device, so the sensor wiring can be grounded. If a grounded thermocouple is used, that will be the one ground point for the sensor wiring.

Shielded cable around the loop wiring should be grounded at the power supply and floating (ungrounded) at the transmitter. Do not ground the loop shield to the transmitter

Shielded cable around the sensor wiring should be grounded at the sensor, not at the transmitter.

The electronic module is not metallic and therefore does not need to be grounded. For certain installations, a ground screw inside the housing is provided. For certain electrical safety certifications, an external ground screw is provided (see Figure 8 for location).

## HART Multidrop Communication

“Multidropping” refers to the connection of several transmitters to a single communications transmission line. Communications between the host computer and the transmitters takes place digitally with the analog output of the transmitter deactivated. With the HART communications protocol, up to 15 transmitters can be connected on a single twisted pair of wires or over leased telephone lines.

The application of a multidrop installation requires consideration of the update rate necessary from each transmitter, the combination of transmitter models, and the length of the transmission line. Multidrop installations are not recommended where Intrinsic Safety is a requirement. Communication with the transmitters can be accomplished with commercially available Bell 202 modems and a host implementing the HART protocol. Each transmitter is identified by a unique address (1-15) and responds to the commands defined in the HART protocol.

Figure 17 shows a typical multidrop network. Do not use this figure as an installation diagram. Contact the HART Communications Foundation (512-794-0369) with specific requirements for multidrop applications.

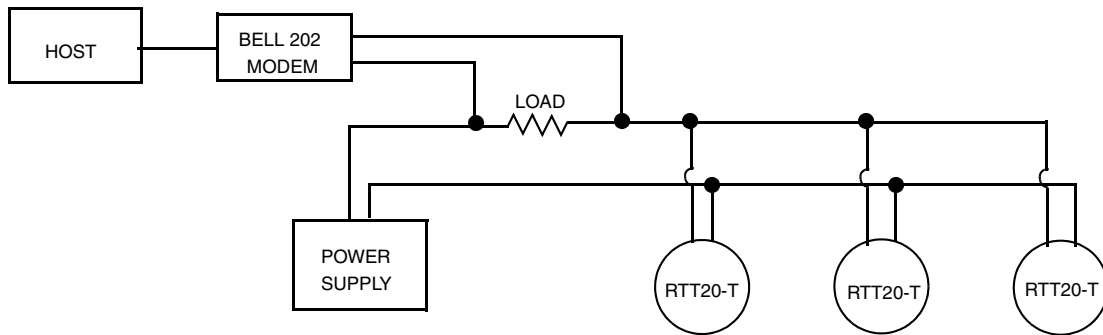

*Figure 17. Typical Multidrop Network*

The HART Communicator or the PC-Based Configurator can operate, configure, and calibrate the RTT20-T in the same way as it can a RTT20-T in a standard point-to-point installation.

**— NOTE —**

RTT20 Transmitters are set to address 0 at the factory, allowing them to operate in the standard point-to-point manner with a 4 to 20 mA output signal. To activate multidrop communication, the transmitter address must be changed to a number from 1 to 15. This change deactivates the 4 to 20 mA analog output.

# 3. Operation

In normal operation, the RTT20 Transmitter continuously receives input signals from RTDs, thermocouples, ohms sensors, or dc mV sources and transmits a linear 4 to 20 mA dc or FoxCom digital output signal. The 4 to 20 mA output and configurable parameters can be displayed via a PC-Based Configurator or HART Communicator and the optional 3-Line Indicator/Configurator.

The optional indicators can be configured to display the output in any one of five different ways as follows:

- EGUs* = displays the measured value (temperature)
- %* = displays the percent of output based upon the calibrated range
- mA* = displays the mA output value between 4 and 20 mA
- EGU and mA* = alternates between the EGU and mA value
- % and EGU* = alternates between the % and the EGU

The 1-Line Indicator displays the output on its 4-digit display. It also automatically displays alternating flashing messages “FAIL” and “SAFE” to denote a sensor or transmitter fault. An indication of -999 or 9999 indicates that the output has exceeded the limits of the display.

The 3-Line Indicator displays the output on the first line of its display. The second line of this indicator is an 11-segment bargraph that displays readings in percent of calibrated range. Temperatures outside the calibrated range are indicated by a left-pointing (underrange) or right-pointing (overrange) arrow. The third line displays seven character user configurable tag information. It also automatically displays the following fault messages:

- ◆ 9999.9°C (or F) on the first line of the display to denote that the temperature exceeds the limit of the display. The third line will read DFAIL.
- ◆ Alternating flashing messages “FAIL” and “SAFE” on the third line of the display to denote a sensor or transmitter fault.

When a sensor or transmitter fault occurs and the problem has been corrected, the output automatically resumes normal operation. On the HART version, the power supply must be cycled if the Failsafe Reset is configured as Latched.

---

## — NOTE —

The RTT20 Transmitter performs multiple sensor and transmitter validity checks. Under certain startup and power conditions, the transmitter with HART communications can take longer to complete those tasks than the allotted ‘startup time’. This momentarily trips the sensor failure diagnostics bit. Therefore, if you have a transmitter with HART protocol and are using the Historical Diagnostics data bit, Foxboro recommends that you perform a ‘Clear Historical Data’ function through a HART Communicator or PC-Based Configurator.

---



# 4. Configuration

The RTT20 Transmitters are programmed internally with the characteristics of all the sensor types that can be attached. Configuration is therefore simplified to selecting a few operating parameters.

The RTT20 Transmitter may be configured before or after installation in the field. It may be useful to configure the transmitter on the bench before installation to ensure that all the configurable parameters are configured correctly for each application. To configure the transmitter on the bench:

1. Connect the transmitter to a 24 V dc power supply (see Figure 14 for allowable power supply voltage and output load limitations).
2. Make sure there is a load of at least 200  $\Omega$  in the loop for output code -D and 250  $\Omega$  for output code -T to ensure proper communications (not required with output code -I).
3. If the transmitter is not supplied with an integral sensor, attach the sensor to be used to the proper screws (see Figures 10 and 12). The transmitter can be configured without a sensor on the bench. However, if this is done and the FAILSAFE parameter is **not** configured for OFF, the transmitter reports a failure.
4. Review all of the configurable parameters and change any as required using the optional Indicator/Configurator or applicable remote configurator.

If the transmitter is to be configured in the field, proceed with the installation (loop wiring, sensor wiring, and mechanical installation), and then review the configurable parameters and reconfigure as required.

## Configurable Parameters

The RTT20 Transmitter is microprocessor based. All adjustments to the transmitter can only be performed via the integral or remote configurators.

---

### — NOTE —

Remote configurators can only be used with the HART and Intelligent versions. The 4 to 20 mA version (Output Code -I) does not contain a modem, so remote communications are not available. Therefore, all adjustments can be performed with the 1- or 3-line integral indicators only.

---

There are no mechanical jumpers, potentiometers, or switches that are normally part of an analog type transmitter. The following pages list all of the configurable parameters and the factory default for each of the three different output types. The factory default values have been customized if the transmitter was ordered with optional feature -C1 or -C2. The tables also show which parameters are configurable with the integral vs. remote configurators. Following the tables is an explanation for each parameter.

Table 6. RTT20 with Intelligent Output (Code -D)

Parameter	Capability	Factory Default	Configurable with		Application Requirement
			Integ. Indic.	Remote Config.	
<b>Descriptors</b>					
Tag Number	12 characters max	Blank	No	Yes	_____
Tag Name	14 characters max	Tag Name	No	Yes	_____
Location	14 characters max	Location	No	Yes	_____
Device Name	6 characters max	DevNam	No	Yes	_____
<b>Output</b>					
Output	4 to 20 mA/Digital	4 to 20 mA	No	Yes	_____
EGUs	C, F, K, R, mV, ohms	Note 1	Yes	Yes	_____
Linearization Mode	EGU or Dewpoint	EGU	No	Yes	_____
<b>Input</b>					
Input Type	RTD, T/C, mV, $\Omega$ , spec	per Model Code	Yes	Yes	_____
Lower Range Value (LRV)	per Model Code	Note 1	Yes	Yes	_____
Upper Range Value (URV)	per Model Code	Note 1	Yes	Yes	_____
Cold Junction	Internal, External, Fixed, Disabled	Internal	No	Yes	_____
Cold Junction EGU	C, F	C	No	Yes	_____
<b>For RTD Measurement Only</b>					
Number of Sensors	Single or Dual	Single	No	Yes	_____
For single RTD	2, 3, or 4 wire	3 wire	Yes	Yes	_____
For Dual 2 wire RTD	Average or Difference	per order	No	Yes	_____
For Dual 3 or 4 wire RTD	Not Available				
<b>Other</b>					
Sensor Fault Detection	On/Off	On	Yes	Yes	_____
Failsafe (mA output only)	On/Off	On	Yes	Yes	_____
Failsafe Value	Note 2	21.00 mA	No	Yes	_____
Power Supply Freq. (Hz)	50/60	60	No	Yes	_____
Power Supply Filter	Standard/High	High	No	Yes	_____
Damping	0 to 32 seconds	0	No	Yes	_____
Sensor Validation	0.25 to 10.0 seconds	0.5	No	Yes	_____
Intelligent Smoothing	0 to 30 seconds	10	No	Yes	_____
Calibrator's Initials	6 characters max	CALINT	No	Yes	_____
<b>3-Line Indicator/Configurator</b>					
Push Buttons	Enable or Disable	Enable	No	Yes	_____
Display (Top line)	Note 3	EGU	No	Yes	_____
Display (Bottom line)	7 characters max	FOXBORO	No	Yes	_____
Configuration Language	Eng, Fr, Ger, Span	English	Yes	Yes	_____

## NOTES:

- Transmitter is configured for 0 to 100 Deg C if calibrated range is not provided.
- The mA failsafe value is user configurable between 3.6 and 3.8 mA for downscale failsafe or between 20.75 and 23.0 mA for upscale failsafe. Factory default is 3.6 mA for downscale failsafe or 21.00 mA for upscale.
- The indicator can be configured to display the output in any one of five different ways as follows:

EGUs	=	displays the measured value (temperature)
%	=	displays the percent of output based upon the calibrated range
mA	=	displays the mA output value between 4 and 20 mA
EGU and mA	=	alternates between the EGU and mA value
% and EGU	=	alternates between the % and the EGU

Table 7. RTT20 with HART Output (Code -T)

Parameter	Capability	Factory Default	Configurable with		Applic. Req.
			Integ. Indic.	Remote Config.	
Descriptors					
Tag Number	8 characters max	Per S.O.	No	Yes	_____
Tag Name (Description)	16 characters max	Tag Name	No	Yes	_____
Message	32 characters max	Blank	No	Yes	_____
Output					
EGUs	C, F, K, R, mV, ohms	Note 1	Yes	Yes	_____
Linearization Mode	EGU/Dewpoint	EGU	No	Yes	_____
Burst Mode	On/Off	Off	No	Yes	_____
Multidrop Address	0 to 16	0	No	Yes	_____
Input					
Input Type	RTD, T/C, mV, $\Omega$ , spec	per Model Code	Yes	Yes	_____
Lower Range Value (LRV)	per Model Code	Note 1	Yes	Yes	_____
Upper Range Value(URV)	per Model Code	Note 1	Yes	Yes	_____
Cold Junction	Internal, External, Fixed, Disabled	Internal	No	Yes	_____
Cold Junction EGU	C, F	C	No	Yes	_____
For RTD Measurement Only					
Number of Sensors	Single or Dual	Single	No	Yes	_____
For Single RTD	2,3, or 4 wire	3 wire	Yes	Yes	_____
For Dual 2 wire RTD	Avg, Diff, or Indep	per order	No	Yes	_____
For Dual 3 or 4 wire RTD	Not Available				_____
Other					
Sensor Fault Detection	On/Off	On	Yes	Yes	_____
Failsafe	On/Off	On	Yes	Yes	_____
Failsafe Value	Note 2	21.00 mA	No	Yes	_____
Failsafe Reset	Auto/Latched	Auto	No	Yes	_____
Power Supply Freq. (Hz)	50/60	60	No	Yes	_____
Power Supply Filter	Standard/High	High	No	Yes	_____
Damping	0 to 32 seconds	0	No	Yes	_____
Sensor Validation	0.25 to 10.0 seconds	0.5	No	Yes	_____
Intelligent Smoothing	0 to 30 seconds	10	No	Yes	_____
3-Line Indicator/Configurator					
Push Buttons	Enable or Disable	Enable	No	Yes	_____
Display (Top line)	Note 3	EGU	No	Yes	_____
Display (Bottom line)	7 characters max	FOXBORO	No	Yes	_____
Configuration Language	Eng, Fr, Ger, Span	English	Yes	Yes	_____

## NOTES:

1. Transmitter configured for 0 to 100 Deg C if calibrated range is not provided.
2. The mA failsafe value is user configurable between 3.6 and 3.8 mA for downscale failsafe or between 20.75 and 23.0 mA for upscale failsafe. Factory default is 3.6 mA for downscale failsafe or 21.00 mA for upscale.
3. The indicator can be configured to display the output in any one of five different ways as follows:
 

EGUs	=	displays the measured value (temperature)
%	=	displays the percent of output based upon the calibrated range
mA	=	displays the mA output value between 4 and 20 mA
EGU and mA	=	alternates between the EGU and mA value
% and EGU	=	alternates between the % and the EGU

Table 8. RTT20 with 4 to 20 mA Output (Code -I)

Parameter	Capability	Factory Default	Application Requirement
<b>Output</b>			
EGUs	C, F, R, or K	Note 1	_____
Linearization Mode	EGU (Dewpoint not available — Use Output Code -D or -T)		_____
<b>Input</b>			
Input Type	RTD, T/C, mV, $\Omega$	Note 4	_____
Special or Custom Curve	Not Available (Use Output Code -D or -T)		_____
Lower Range Value (LRV)	per Model Code	Note 1	_____
Upper Range Value (URV)	per Model Code	Note 1	_____
<b>For RTD Measurement Only</b>			
Number of Sensors	Single	Single	_____
For single RTD	2, 3, or 4 wire		_____
For Dual 2 wire RTD	Not Available (Use Output Code -D or -T)		_____
<b>Other</b>			
Sensor Fault Detection	On/Off	On	_____
Failsafe	On/Off	On	_____
Fail Safe Direction	Up (21 mA) or Down (3.6 mA)	Up	_____
<b>3-Line Indicator/Configurator</b>			
Configuration Language	English, German, French, Spanish	English	_____

## NOTES:

- Transmitter is configured for 0 to 100 Deg C if calibrated range is not provided.
- The mA failsafe value is user configurable for Output Codes -D and -T between 3.6 and 3.8 mA for downscale failsafe or between 20.75 and 23.0 mA for upscale failsafe. Factory default is 21.00 mA for upscale and 3.6 mA for downscale failsafe.
- The 1-line indicator and the top line of the 3-line indicator for Output Code -D and -T can be configured to display the output in any one of five different ways, as follows:

EGUs	=	displays the measured value (temperature)
%	=	displays the percent of output based upon the calibrated range
mA	=	displays the mA output value between 4 and 20 mA
EGU and mA	=	alternates between the EGU and mA values
% and mA	=	alternates between the % and mA values
- Input: Types limited to the following:

RTD	Pt 100 DIN/IRC
	Pt 100 SAMA
T/C	Types B, C, E, J, K, L, N, R, S, T, U
mV	
Ohm	

**— NOTE —**

Adjustments to the transmitter with 4 to 20 mA output (Code -I) can only be performed using the 3-line LCD Indicator/Configurator. Remote communication is available with -D and -T transmitters.



## Parameter Descriptions

To help guide you through the configuration of the transmitter, the following is a brief description of the configurable parameters. Please remember that not all parameters are applicable to all three different types of outputs, and not all parameters are configurable from the integral Indicator/Configurators.

### Descriptors (Applicable to Intelligent and HART Output Versions Only)

<b>Tag Number</b>	Normally configured to the plant tag number, such as <i>TT301B</i> . The Tag Number is the primary identifier when communicating with a transmitter using a remote configurator. This field is different than the bottom line of the 3-line indicator, unless both are configured to be the same.
<b>Tag Name or Message</b>	Normally configured as the Tag Name, such as <i>BOILER TEMP</i> .
<b>Location</b>	Normally configured to show where the transmitter is located, such as <i>PLANT 2A</i> .
<b>Device Name</b>	This field is only applicable to Intelligent transmitters configured for digital output and wired to FBM18, 39, 43, 44, or 46. This field is the “letterbug” of the transmitter to ensure that the system is digitally connected to the correct transmitter. The default for this parameter is <i>DevNam</i> for secure protocol with I/A Series Control systems with 3.0 or later software.

### Output

<b>Output</b>	This parameter is applicable to the Intelligent output version only. The output is configurable for <i>4 to 20 mA</i> output or <i>digital</i> . Digital is used only when the output is to be digitally integrated to I/A Series System through FBM18, 39, 43, 44, or 46. When configured for digital output, communications between the transmitter and the control system occur at 10 times per second.
<b>Engineering Unit (EGU)</b>	Configurable to C, F, K, or R for thermocouple or RTD sensors. If the input is configured for <i>mV</i> or <i>ohms</i> , the engineering units should be mV or ohms, respectively.
<b>Linearization Mode</b>	Configurable for <i>EGU</i> or <i>Dewpoint</i> . This parameter should be set to EGU to make the output linear with temperature. It should be configured for Dewpoint only when the output wants to be linear with Dewpoint (for example, when using Foxboro 2781 Dewpoint sensor as the input).
<b>Burst Mode</b>	Applicable to HART output version only. In the <i>Off</i> position, digital communications over the HART network occur at 2 times per second. This parameter should be turned <i>On</i> only if the transmitter is communicating digitally to a HART compatible control system and the multidrop address is set to 0. When in the Burst mode, it provides faster digital communications (approx 3 times per second) from the transmitter to the host control system. Burst mode cannot be used with multidrop wiring.

**Multidrop Address** Applicable to HART output version only. The default of 0 allows the transmitter to operate in the standard point-to-point, two wire 4 to 20 mA mode. If the transmitter is to be multidrop wired, the address must be changed to a number from 1 to 15. All transmitters installed in a multidrop node must have a different multidrop address, and Burst mode must be configured *Off*. With multidrop operation, the analog current value will be fixed at 4 mA. A maximum of 15 transmitters can be multidropped (networked) over a single pair of wires. For intrinsically safe applications, the maximum number of transmitters per multidrop node is 3 or 4, depending upon the barrier used. However, the HART Communication Foundation does not recommend multidrop installations for intrinsically safe applications.

## Input

**Input** Configurable for all popular RTDs and thermocouples. When an RTD is selected, you must also select whether it is a 2-, 3-, or 4-wire sensor (Measurement Mode). Can also be configured for various mV or ohms sources.

---

### — CAUTION

In the Input selection area, there are multiple special selections, namely *Special T/C*, *Special RTD*, and *Special Input*. These selections are only used when the factory installs a nonstandard sensor curve into the transmitter. They must **not** be selected when the user is trying to implement a Custom Curve. Refer to the Custom Curve portion of the Calibration menu.

---

<b>Measurement Mode</b>	Selected to match the number of wires coming from the sensor (2-, 3-, or 4-wire).
<b>Lower Range Value (LRV) or Zero</b>	This is the measurement value corresponding to the 4 mA point. This value can be electronically changed without the need for calibration equipment.
<b>Upper Range Value (URV) or Full Scale</b>	This is the measurement value corresponding to the 20 mA point. This value can be electronically changed without the need for calibration equipment.
<b>Cold Junction</b>	The cold junction reference is used with thermocouple input and FoxCom or HART Output (code -T) only. The junction can be programmed for <i>Internal</i> , <i>External</i> , <i>Fixed</i> , or <i>Disabled</i> .

---

### — CAUTION

Incorrect thermocouple measurements will result if the cold junction settings do not match the installed transmitter. “Fixed” or “Disabled” should only be used during diagnostic evaluation or calibration.

---

<b>Cold Junction (EGU)</b>	The engineering units that are displayed on the remote configurators for the cold junction temperature can be configured for <i>F</i> or <i>C</i> . Used with thermocouple input only.
----------------------------	--

## Other

<b>Sensor Fault Detection or Sensor Failsafe</b>	The transmitter checks for sensor problems every three seconds. If configured for <i>ON</i> and a fault is detected, the output goes to the configured failsafe condition. If configured for <i>OFF</i> , the output will not be forced to the failsafe value when a sensor fault is detected.
<b>Failsafe (mA output only)</b>	If the transmitter detects an internal fault or a sensor fault (when configured for <i>ON</i> ), the mA will be driven to the failsafe value.
<b>Failsafe Value or Failsafe Report</b>	When the Failsafe is turned On and a fault is detected, the output will be driven below 4 mA or above 20 mA. On the 4 to 20 mA version (Code-I), the values are set at 3.6 and 21 mA. On the HART and Intelligent versions, the milliamp failsafe current is adjustable between 3.6 and 3.8 mA for downscale and between 20.75 and 23.00 mA for upscale failsafe.
<b>Failsafe Reset</b>	When a transmitter or sensor fault occurs and the problem has been corrected, the output will return to normal operation if configured to <i>AUTO</i> . If configured for <i>LATCHED</i> , the power supply will have to be turned off and back on before the transmitter will resume normal operation. This parameter is applicable to HART output (code -T) only.
<b>Power Supply Freq</b>	Should be set to the ac frequency of the power supply, either <i>50</i> or <i>60 Hz</i> .
<b>Power Supply Filter</b>	This parameter helps eliminate noise originating from the power supply. This should always be set to <i>HIGH</i> . Set to <i>STD</i> only if you require extremely fast response with the damping value set for 0 seconds.
<b>Damping</b>	The basic transmitter has a response time of approximately 1.2 seconds for a 90% response to an 80% input step. For processes which have temperature swings that are beyond the Intelligent Smoothing band, and require a damped output, increase the damping to a higher value. The damping is selectable between 0 and 30 seconds. Before increasing the damping, it is suggested that you increase the Intelligent Smoothing time and the Sensor Validation time to the maximum before increasing the damping value.
<b>Sensor Validation</b>	Adjustable between 0 and 10 seconds. This is the lag time that the microprocessor holds and compares the input to past inputs. If the value does not match the pattern determined by three different filters, that value is discarded rather than used as a measurement. Increasing the sensor validation time eliminates spikes due to input (sensor) noise.

---

### — CAUTION —

Under certain noisy electrical conditions, the output of a Code -D transmitter may exhibit a short duration spike when configured for 0.0 seconds. The configurator software is being revised to 0.25 seconds minimum sensor validation time. Foxboro does not recommend 0.0 seconds on any transmitter used in a control loop. This is not a problem with conventional output Code -I and HART output (Code -T) transmitters.

---

<b>Intelligent Smoothing</b>	Any process or electrical noise is eliminated by a digital filtering algorithm and is smoothed by averaging the input over an adjustable time period. The averaging time can be set between 0 and 30 seconds. The Intelligent smoothing action is bypassed with 0 seconds, or maximized with 30 seconds. When the input changes quickly, the smoothing band is exceeded and the output tracks the input, temporarily bypassing the smoothing action. Once the input settles at a new value, the filtering algorithm is automatically reactivated, eliminating noise and producing an accurate and stable output. The smoothing band is approximately $\pm 0.6$ ohms or $\pm 0.5$ mV, depending upon input configuration (RTD vs. T/C), and is not adjustable. Therefore at a 100°C measurement, the intelligent smoothing band is approximately $\pm 2^\circ\text{C}$ for an RTD or $\pm 8^\circ\text{C}$ for a thermocouple.
<b>Calibrators Initials</b>	The 6-character field can be used to designate who calibrated the transmitter. It can also be used to insert the date of last calibration ( <i>Jun 96</i> , for example).

### 3-Line Indicator/Configurator

<b>Pushbuttons</b>	Configurable to <i>Enable</i> or <i>Disable</i> from the 3-line indicator/configurator. <i>Disable</i> would be selected for security reasons only if you do not want anyone to reconfigure the transmitter from the integral Indicator. Note that this is set in the transmitter, not the 3-line indicator/configurator. Therefore, if a transmitter has the pushbuttons disabled, it is disabled for any indicator. This is not a configurable parameter on the 4 to 20 mA output version (Output Code -I), because the transmitter can be reconfigured <i>only</i> through the Indicator.
<b>Display</b>	The top line of the 3-line indicator can be configured to display the output in any one of five different ways as follows: <ul style="list-style-type: none"> <li><i>EGUs</i> = displays the measured value (temperature)</li> <li><i>%</i> = displays the percent of output based upon the calibrated range)</li> <li><i>mA</i> = displays the mA output value between 4 and 20 mA</li> <li><i>EGU and mA</i> = alternates between the EGU and mA value</li> <li><i>% and EGU</i> = alternates between the % and the EGU</li> </ul> The indicator pushbuttons are not active when the display is configured in the alternating mode with software Rev 1. The pushbuttons are active with transmitter software Rev. 2 or later.
<b>Display (Bottom line)</b>	Normally configured to the plant tag number, such as TT301B.
<b>Configuration Language</b>	The configuration language used by the 3-line indicator can be configured to <i>English, French, Spanish</i> or <i>German</i> .

## Indicator/Configurator

An optional 3-Line Indicator/Configurator can be added to your transmitter or moved from transmitter to transmitter. See Figure 18.

In normal mode, the 3-Line Indicator displays the output on the first line of its display. In configuration mode, it displays configuration values. (When configured for mV input, the display goes blank with inputs exceeding 99 mV.) The second line of this indicator is an 11-segment

bargraph that displays readings in percent of calibrated range. Temperatures outside the calibrated range are indicated by a left-pointing (underrange) or right-pointing (overrange) arrow. The third line displays seven character user configurable tag information in normal mode.

In normal operating mode, the 3-Line Indicator also automatically displays the following fault messages:

- ◆ 9999.9°C (or F) on the first line of the display to denote that the temperature exceeds the limit of the display. The third line will read DFAIL.
- ◆ Alternating flashing message “FAIL” and “SAFE” on the third line of the display to denote a sensor or transmitter fault.

In configuration mode, this line displays the menu item.

Addition of the Indicator/Configurator is accomplished by merely plugging it in. See Figure 19.

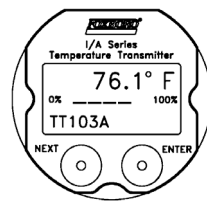

*Figure 18. 3-Line Indicator*

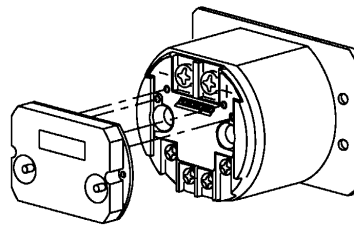

*Figure 19. Addition of Indicator/Configurator*

Changing the configuration with the Indicator/Configurator is similar to setting the time on a digital watch. The transmitter steps through a menu of parameters in response to the NEXT/NO and ENTER/YES buttons on the indicator faceplate. See Tables 6 through 8. Whenever the buttons are being used to reconfigure a transmitter, if neither button is pressed during a 2-minute period, the transmitter returns to normal operation. Also, if the power is interrupted for more than 10 seconds in the configuration mode, the transmitter returns to normal operation.

Press the NEXT/NO button to move to the next item in the menu structure or to answer “No” to a prompt question. Press the ENTER/YES button to accept or enter an item or to answer “Yes” to a prompt question.

## Configuration Procedure

1. Connect a 24 V dc power supply to the transmitter. Observe correct polarity of the power supply and transmitter connections.
2. Turn on the power supply and wait until the display is functional (typically 5 to 8 seconds).
3. Following the configurator flowchart (Figure 20), use the NEXT/NO button to go to the first parameter to be reconfigured and press ENTER/YES. Continue to follow the flowchart to configure your transmitter. Note that the flowchart shows both a four-digit code and text in each box. The code is displayed on a 1-Line Indicator and an abbreviated form of the text on the third line of a 3-Line Indicator.

---

**— NOTE**

Not all parameters are configurable using the 1- and 3-line indicator/configurators. The menu selections allow the most common changes to be implemented. For all other parameters, a remote configurator must be used.

---

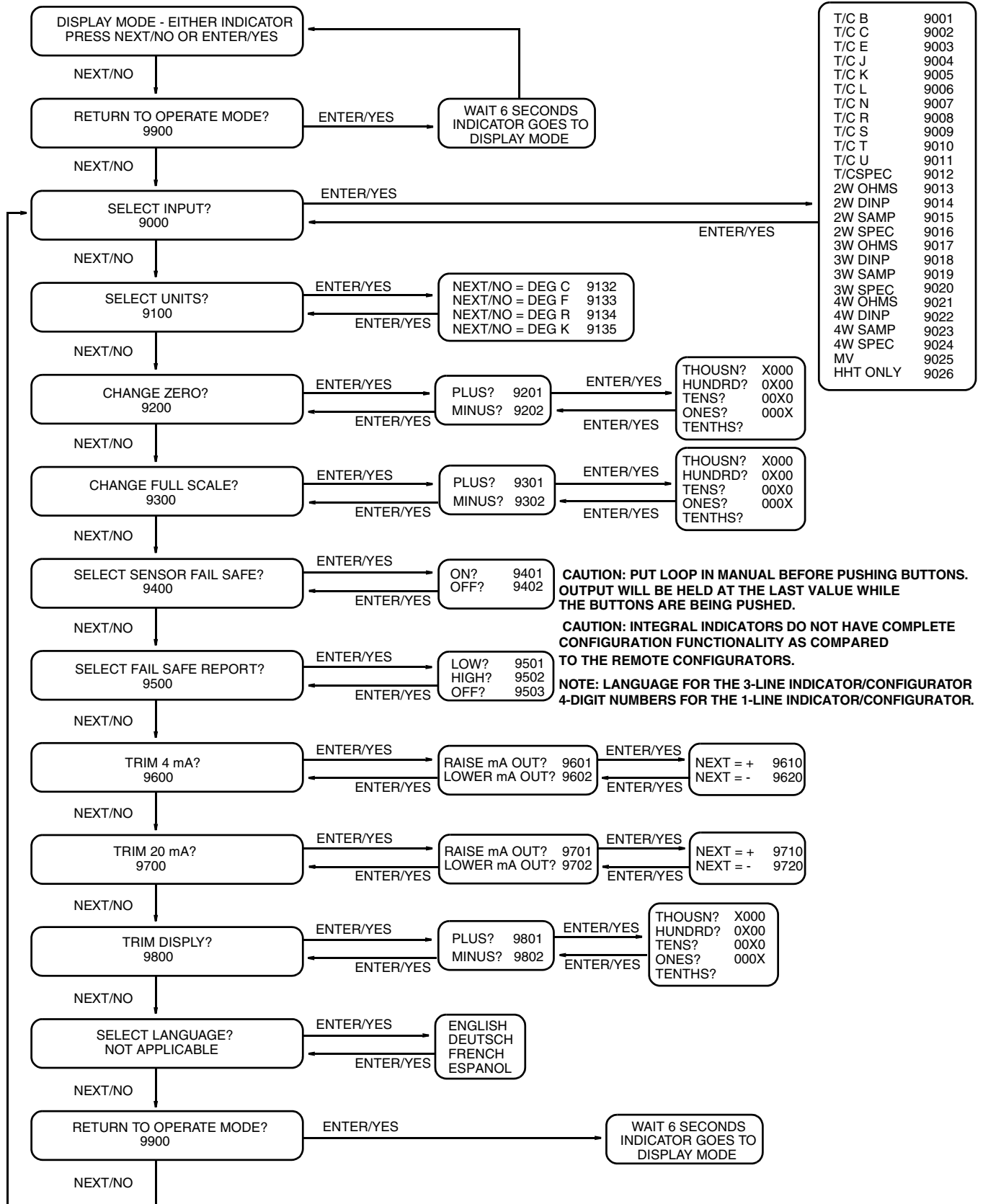

T/C B	9001
T/C C	9002
T/C E	9003
T/C J	9004
T/C K	9005
T/C L	9006
T/C N	9007
T/C R	9008
T/C S	9009
T/C T	9010
T/C U	9011
T/CSPEC	9012
2W OHMS	9013
2W DINP	9014
2W SAMP	9015
2W SPEC	9016
3W OHMS	9017
3W DINP	9018
3W SAMP	9019
3W SPEC	9020
4W OHMS	9021
4W DINP	9022
4W SAMP	9023
4W SPEC	9024
MV	9025
HHT ONLY	9026

**CAUTION: PUT LOOP IN MANUAL BEFORE PUSHING BUTTONS. OUTPUT WILL BE HELD AT THE LAST VALUE WHILE THE BUTTONS ARE BEING PUSHED.**

**CAUTION: INTEGRAL INDICATORS DO NOT HAVE COMPLETE CONFIGURATION FUNCTIONALITY AS COMPARED TO THE REMOTE CONFIGURATORS.**

**NOTE: LANGUAGE FOR THE 3-LINE INDICATOR/CONFIGURATOR 4-DIGIT NUMBERS FOR THE 1-LINE INDICATOR/CONFIGURATOR.**

Figure 20. Indicator Configurator Flowchart





# 5. Calibration

The RTT20 Transmitter has an advanced self-calibration routine that greatly extends the time between recalibrations. Every three seconds, the transmitter checks the zero and full scale output against highly accurate and stable internal voltage signals that are referenced back to the factory calibration stored in nonvolatile EEPROM memory. Any adjustments are made automatically without interrupting the output signal.

The following sections display and describe procedures for transmitter calibration. Use test equipment that is at least three times as accurate as the desired accuracy of the transmitter. Trimming the 4 to 20 mA output is performed by setting the module to output either 4 or 20 mA, and then comparing the loop current to a known standard. Input calibration is performed by simulating the electrical behavior of the sensor with a known standard input device, then comparing the transmitter output to the expected value.

Note that “Trimming 4 to 20 mA Output” is available on all three transmitter output types. “Input Calibration” is only available on the Intelligent (-D) and HART (-T) output types.

## Trimming 4 to 20 mA Output

If you have a 4 to 20 mA output, you may trim the output at 4 mA and 20 mA by connecting a digital voltmeter and precision resistor in the output loop (see Figure 21) and adjusting the output in Configuration Mode. For the procedure using the integral indicator/configurator, see the flowchart in Figure 20. For the procedure using a remote configurator, see MI 020-495 (PC20 Configurator), MI 020-501, 504, and 505 (PC50 Configurator), or MI 020-460 (HART Communicator).

Negative adjustments (either 4 or 20 mA point, but not both) using Output Trim on the local display or mA Cal on the remote configurators force the mA output to the maximum positive current on a FoxCom transmitter (Output Code -D) with Rev 2 or earlier software. Do a Restore Factory mA with the PC-Based Configurator and adjust the output with “1-point Cal”. Contact Foxboro for a field upgrade kit. The “Output Trim/mA Cal” function works correctly with transmitter software Rev 3 or later.

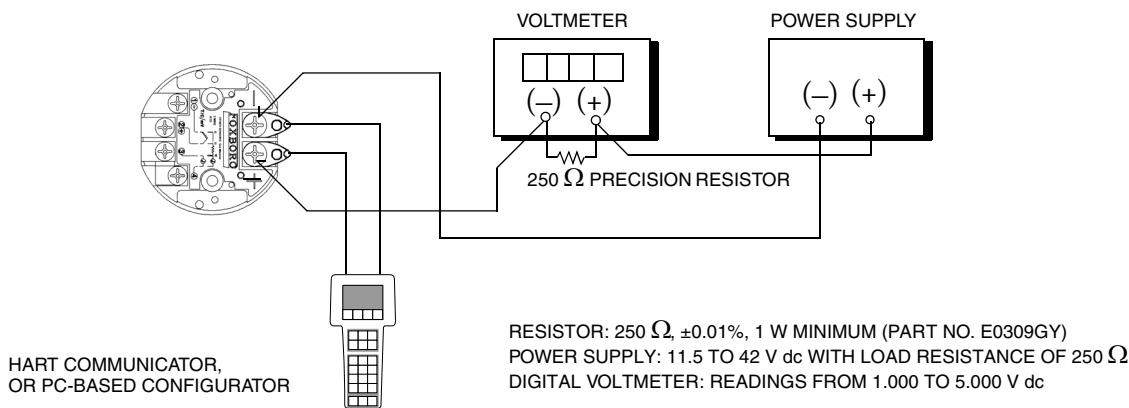

Figure 21. 4 to 20 mA Output Calibration Setup

## Input Calibration

Connect the configured transmitter as shown in Figure 22. Sensor input connections to the transmitter should be made per the diagrams shown in Figure 10 on page 20 (Single RTD), Figure 11 on page 21 (Dual RTD), or Figure 12 on page 22 (Thermocouple or Voltage). Do not use any sort of quick disconnect or clip connections on the sensor input connections since added contact resistance can cause an inaccurate calibration.

Unless an N-point calibration is being performed, make sure that the Sensor Fault Detection is off before taking calibration measurements. Interaction between the transmitter Sensor Fault Detection and external calibration devices such as a millivolt current source can cause an inaccurate calibration. After the calibration is completed, the Sensor Fault Detection can be restored to its original configuration.

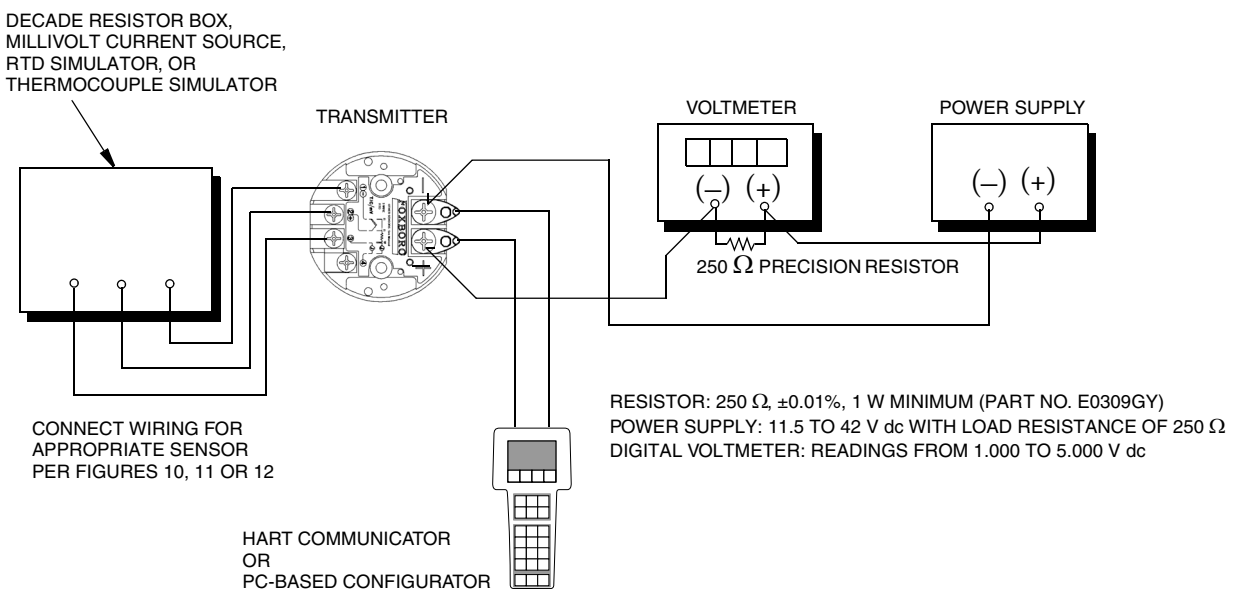

Figure 22. Input Calibration Setup

## N-Point Calibration

A computer-assisted 1-, 2-, 3-, or 5-point calibration may be performed with the PC-Based Configurator. Note that the PC-Based Configurator automatically switches off the Sensor Fault Detection, then automatically restores the Sensor Fault Detection to its pre-calibration settings. Performing an N-Point Calibration overwrites any existing Input Calibration data contained in the transmitter (see “Custom Curve Calibration”, which follows).

## Custom Curve Calibration

The RTT20 Transmitter with FoxCom (-D) or HART (-T) output modes contains 22 data pairs which are used in Input Calibration. This calibration option is available on the PC-Based Config-

urators and HART Communicator. Refer to MI 020-495 for a PC20 Configurator, MI 020-501, 504, and 505 for a PC50 Configurator, and MI 020-460 for the HART Communicator.

Each data pair contains an “x value” which contains the Actual (Observed) Measurement and the corresponding “y value” which contains the Desired Reading. When the transmitter database indicates that there are a number of characterization points activated, it automatically interpolates output values by mapping the intermediate (uncorrected) output through the Custom Curve function defined by the data pairs.

The general procedure is as follows:

1. Enter the total number of points to be corrected (2 to 22). Then enter the calibration points, starting at the low value and ending at the high value.
2. Enter the actual (observed) measurement value for the first point (LowPt).
3. Enter the desired reading for the first point (LowCor).
4. Repeat Steps 2 and 3 for all points to be corrected.
5. Download all sets of points into the transmitter.

The calibration example below illustrates the use of Steps 2 through 4 above.

If the transmitter needs to be calibrated at five points from 0 to 100°C (0, 25, 50, 75, and 100°C) and the actual measured values are 0.23, 25.5, 50.6, 75.4, and 100.4, then the values you should enter in the TranCal locations are:

	Actual (Observed) Measurement	Desired Reading
Low Pt	0.23°C	0°C
2nd Pt	25.5°C	25°C
3rd Pt	50.6°C	50°C
4th Pt	75.4°C	75°C
5th Pt	100.4°C	100°C

---

— **NOTE** —

Since it is not possible to leave the default values in memory when performing a custom input curve calibration, it is **strongly recommended** that the transmitter data base, with the Number of Points = 0, be stored to a file prior to making drastic changes in the calibration data.

---



---

—  **CAUTION** —

Calibrating data is stored in a single data array in the transmitter EEPROM. Performing any calibration overwrites the existing calibration data. Foxboro recommends that you save the transmitter database to a file before you recalibrate the transmitter.

---



# 6. Maintenance

The RTT20 Transmitter basic unit has no moving parts and is a completely sealed unit. If there is a problem, refer to the following troubleshooting section for possible corrective actions. If you cannot find any external problem, contact you local Foxboro representative or return the transmitter to Foxboro for repair.

---

**—▲ CAUTION**

The transmitter is completely sealed unit and cannot be repaired. Any attempt to open the basic transmitter will void the warranty.

---

---

**—▲ DANGER**

For nonintrinsically safe installations, to prevent a potential explosion in a Division 1 hazardous area, deenergize transmitter before you remove threaded housing cover. Failure to comply with this warning could result in an explosion resulting in severe injury or death.

---

## Troubleshooting Problems

Normally, any problem activates a fault message on the optional indicators or remote configurators, alerting the user that there is a problem. The following lists various problems and corrective actions:

### Communication Failures with Remote Configurators

- ◆ Confirm that the power supply meets specifications for current, voltage, ripple, and noise.
- ◆ Follow troubleshooting information in the appropriate instruction: PC20 Configurator (MI 020-495), PC50 Configurator (MI 020-501, 504, and 505) or HART Communicator (MI 020-460).
- ◆ Refer to Fault Analysis section of the applicable remote configurator.
- ◆ Refer to Attaching Remote Configurators.

### Nothing Displayed on Indicator

- ◆ Confirm that transmitter is in the operational mode by using a remote configurator.
- ◆ Carefully clean the four gold-plated pins on the back of the indicator and reinstall.
- ◆ Install indicator in another transmitter that is working properly.

### High or Low Output (at FailSafe)

- ◆ Check the process variable to see if it is higher than the Upper Range Value (URV) or below the Lower Range Value (LRV).
- ◆ Check for open or shorted sensor leads.

- ◆ Check loop wiring for corroded connections.
- ◆ Check the calibrated range to ensure that the process variable is less than the URV.
- ◆ Check that the transmitter is configured for the correct sensor type.
- ◆ On transmitter with HART output (Code -T), turn power supply off and then back on if Failsafe Reset parameter is configured as Latched.
- ◆ Negative adjustments (either 4 or 20 mA point, but not both) using Output Trim on the local display or mA Cal on the remote configurators force the mA output to failsafe current on a FoxCom transmitter (Output Code -D) with Rev 2 or earlier software. Do a Restore Factory mA with a PC-Based Configurator and adjust the output with “1-point Cal.” Contact Foxboro for a field upgrade kit. The “Output Trim/mA Cal” function works correctly with transmitter software Rev 3 or later.

### Output Stuck at Zero Degrees

- ◆ Check the Custom Curve parameters. The normal condition is “Number of Cal Points” has a value of 00. But if the Custom Curve operation was done improperly without inserting values for the x and y coordinates, the output could appear frozen. When the RTT20 sees a nonzero value in the number of cal points parameter, the transmitter goes to the 22 point listing and “corrects” the value based on what is found for those points. Using a PC-Based Configurator, perform a Print Complete Database to Screen. The following are correct examples of what should be displayed:
  - ◆ If the number of cal points = 0, X1 through Y22 should all be zero.
  - ◆ If the number of cal points = 2, X1 through Y2 should not be all zeros, and X3 through Y22 should be zero.
  - ◆ If the number of cal points = 5, X1 through Y5 should not be all zeros, and X6 through Y22 should be zero.

For example, the most common misconfiguration would be that the number of cal points = 2 and all of the X1 through Y22 values are zero. The transmitter output promptly goes to a 0 Deg EGU value regardless of the input. The transmitter has been told that the calibrated range is from zero to zero EGUs (F, C, K, or R). To correct the problem, go to the Calibrate section and select Custom Input Curve. When the box opens, you will see Number of Calibration points (0, 2-22): 2. Reset the Number of Cal Points from 2 to 0, then press F4 to download that change. The transmitter will now work properly based upon the factory calibration stored in the transmitter. If a Custom Curve is to be applied, follow the written procedures.

### No Output (0 mA)

- ◆ Check wiring for breaks.
- ◆ Make sure that there is at least 12 V dc at the transmitter loop wiring screws.
- ◆ Check wiring polarity.

### Erratic Output

- ◆ Check for multiple grounds.
- ◆ Check for intermittent shorts or opens in the loop wiring.

### Output Spike

- ◆ Under certain noisy electrical conditions, the output of a Code -D transmitter may exhibit a short duration spike when configured for 0.0 seconds. The configurator software is being revised to 0.25 seconds minimum sensor validation time. Foxboro does not recommend 0.0 seconds on any transmitter used in a control loop. This is not a problem with conventional output Code -I transmitters and output (Code -T) transmitters.

### Transmitter with Output Code -D (Installed as a 4 to 20 mA Transmitter) displays a Constant Output of 12 mA

- ◆ Transmitter is configured for digital output. Reconfigure for analog 4 to 20 mA output.

### Transmitter Output Less Than 20 mA Under All Conditions

- ◆ Make sure that there is at least 12 V dc at the transmitter loop wiring screws. This problem is usually the result of too much load for the power supply, and when the transmitter “wants” to output 20 mA, the voltage at the transmitter drops to less than 12 volts.

### Transmitter Temperature Displayed on Remote Configurator Is Not Close to Ambient Temperature

- ◆ When doing a MEAS command with the remote configurator, the FoxCom transmitter temperature (Rev 1 software) is displayed as 0 °F (-17.78 °C). It is supposed to show the transmitter temperature which is actually the ambient temperature (cold junction temperature). The problem is that the transmitter software is reporting the transmitter temperature on MEAS #2 rather than on MEAS #3. Therefore, because the PC-Based Configurator software is written to display the transmitter temperature from MEAS #3, it will always display 0 °C (17°F). Also, if the transmitters are digitally connected to an I/A Series system, the transmitter temperature will be reported on MEAS #2 rather than on MEAS #3 for all transmitters with Rev 1 software. There is nothing wrong with the transmitters. They are working within specifications. This display problem was corrected in Rev. 2 and later transmitter software.
- ◆ When doing a MEAS command with a PC-Based Configurator, the FoxCom transmitter temperature is incorrectly displayed as -4 °C (24 °F). This is a result of the factory not setting the Secondary Measurement Units correctly. You can view the factory setting by doing a Print Full Database. Scan down the list of configurable parameters and if the Secondary Measurement Units is configured for ff rather than for 20 or 21, this problem has no effect on accuracy and can easily be rectified in the field. Go to the Configure Screen and change the Secondary Measurement Units from °F to °C (or vice versa). Then download the change to the transmitter. Go to the

MEAS screen and confirm that the transmitter temperature is correctly displayed (close to the ambient temperature).

### Indicator Displays Message

- ◆ FAIL and SAFE (alternately) on 1- or 3-line indicator
  - a. Make sure the actual sensor matches the sensor selected in transmitter configuration.
  - b. Make sure the sensor is correctly wired to the transmitter.
  - c. Make sure the electronic sensor configuration is the same as the actual sensor type attached to the transmitter.
  - d. Check to make sure the sensor has not failed.
  - e. If the message only is shown for the first 5 or 10 seconds after power is first applied, it is a normal startup condition on transmitters supplied with Rev 1 software.
- ◆ -999 or 9999 on 1-Line Indicator denotes an output greater than the capability of the display.
- ◆ 9999.9 °C (or F) on the first line and DFAIL on the third line of a 3-Line indicator denotes an output greater than the capability of the display.

### Display Indicates Sensor Fault

- ◆ Check that transmitter is properly configured for the sensor connected.
- ◆ Check sensor wiring connections per transmitter wiring section of this instruction.
- ◆ If using a thermocouple, check the thermocouple resistance by detaching the thermocouple leads at the transmitter and measuring the resistance with an ohmmeter. Over 3000  $\Omega$  of resistance causes a sensor fault. Typically, there is very little resistance. Any value greater than 100  $\Omega$  should be evaluated for a cause such as poor wiring connections or corroded terminals.

### mA Loop Cal Function Does Not Work Properly

- ◆ Any RTT20 transmitter with Output Code -D and Rev 1 transmitter software (shipped between April and October 1996) will not operate properly with the remote configurator loop cal functions unless the MEAS units are configured for degrees C. If the transmitter is configured for degrees F, K or R, the loop cal output goes to 3.8 mA and stays there no matter what output is requested via the remote configurator, or will vary up to approximately 50% of the requested output, depending on the calibrated range. On the other hand, the loop cal works correctly when the transmitter is configured for degrees C. The mA loop cal function was fixed in transmitter software Rev. 2 or later.



## Replacement of Integrally Mounted Sensor

1. Turn off transmitter power source.
2. Remove the housing cover by rotating it counterclockwise. Loosen and turn custody transfer lock first if applicable.
3. Disconnect sensor wires from transmitter terminals.
4. Remove sensor.
5. Install new sensor by reversing Steps 1-4 above.

---

—  **CAUTION** —

When replacing housing cover, hand tighten it as much as possible so that O-ring is fully captured.

---

## Replacement of Basic Transmitter

1. Turn off transmitter power source.
2. Remove the housing cover by rotating it counterclockwise. Loosen and turn custody transfer lock first if applicable.
3. Disconnect input and output wires from transmitter terminals.
4. Remove Basic Transmitter by removing two screws that secure it to the housing or DIN rail.
5. Install new transmitter by reversing Steps 1-4 above.

---

—  **CAUTION** —

1. When replacing the two mounting screws, do not overtighten.
  2. When replacing housing cover, hand tighten it as much as possible so that O-ring is fully captured.
-



# **Index**

## **C**

Calibration 43  
Conduit Drainage 17  
Configuration 31  
Cover Lock 16  
Custody Transfer Lock and Seal 16

## **E**

Electrical Certification Rating 8

## **G**

Grounding (Earthing) 27

## **I**

Identification 2  
Indicator/Configurator 38  
Installation 13

## **L**

Loop Wiring 23

## **M**

Maintenance 47  
Mounting 13

## **O**

Operation 29

## **P**

Parameters, Configurable 31  
Positioning Transmitter 16

## **R**

Reference Documents 2  
Replacement of Basic Transmitter 51  
Replacement of Integrally Mounted Sensor 51

**S**

Sensor Connections and Wiring 20  
Specifications 3

**T**

Troubleshooting 47

**U**

Unpacking 13

**W**

Wiring 17

ISSUE DATES

JAN 2003  
JUL 2003  
JAN 2004  
FEB 2004  
SEP 2004  
SEP 2006  
FEB 2007  
APR 2008

Vertical lines to the right of text or illustrations indicate areas changed at last issue date.

33 Commercial Street  
Foxboro, MA 02035-2099  
United States of America

<http://www.foxboro.com>  
Inside U.S.: 1-866-746-6477  
Outside U.S. 1-508-549-2424 or  
contact your local Foxboro  
Representative.  
Facsimile: (508) 549-4999

Invensys, Foxboro, and I/A Series are trademarks of Invensys plc, its subsidiaries, and affiliates.  
All other brand names may be trademarks of their respective owners.

Copyright 2003-2008 Invensys Systems, Inc.  
All rights reserved

MB 100

Printed in U.S.A.

0408