

PR Series RTDs
Platinum Resistance Temperature Detectors

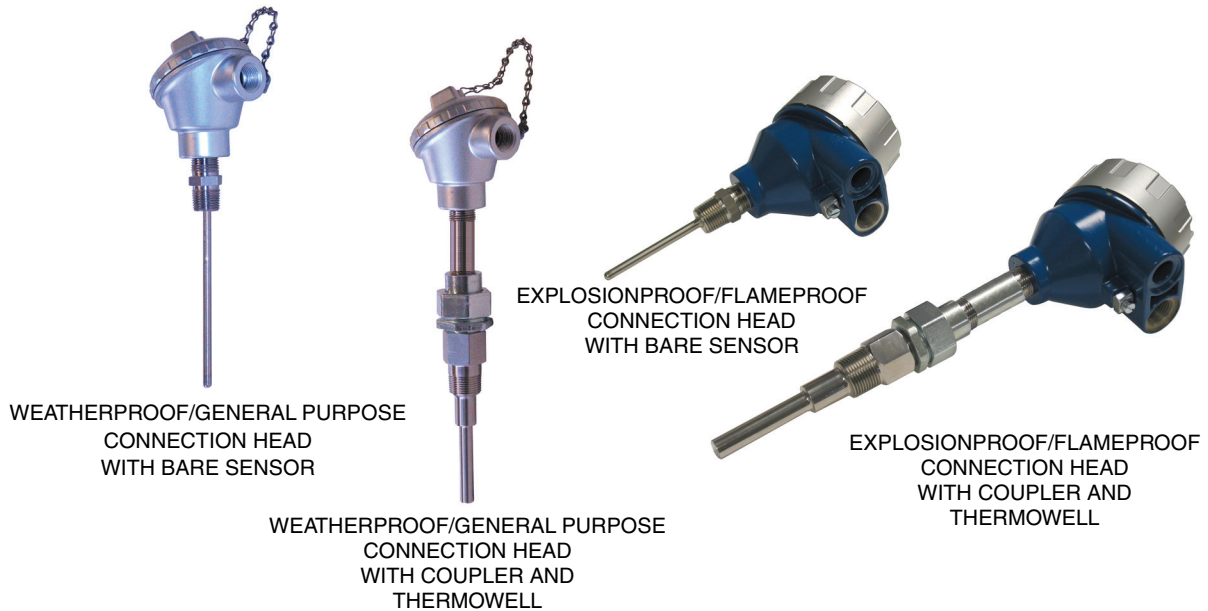

The Foxboro® brand PR Series RTDs are available from Invensys. These RTDs are sensors whose electrical resistance changes with a change in temperature. They measure temperatures from -200 to +650°C (-320 to +1200°F) and are calibrated to ASTM (IEC, DIN) standard curves. The resistance output from the element may be directly connected to a variety of resistance temperature measurement instruments.

WIDE TEMPERATURE RANGE

Platinum RTDs are an ideal selection in applications having a wide temperature range and where maximum accuracy, repeatability, long-term stability, and interchangeability are desired.

USABLE WITH MANY TYPES OF FIELD DEVICES

RTDs may be directly connected to a variety of Foxboro instruments such as transmitters, controllers, compensated totalizers, converters, or system input modules.

A VARIETY OF CONFIGURATIONS

The PR Series can accommodate either a single or dual RTD element. They are available as either bare sheath or well type assemblies. In either configuration, the sensor is protected with a full length moisture resistant sheath of either AISI Type 316 stainless steel (316 ss) or Inconel 600, depending upon the temperature or process material being measured. An excellent selection of specially engineered wells is available to further protect the RTD from physical damage or from corrosive or damaging process media. RTD insertion lengths are available from 51 to 914 mm (2 to 36 in) in 12.7 mm (1/2 in) increments. Custom lengths are also available from 37 through 300 inches in whole inch increments. Weatherproof (IEC IP65, NEMA Type 4) terminal connection heads are offered for general purpose applications, and explosionproof/flameproof (IEC IP65, NEMA Type 4X) terminal connection heads are offered for corrosive or hazardous area installations.

SPRING LOADED CONSTRUCTION WITH WELLS

When wells are used, a spring loading device is used to provide positive tip contact between the element and thermowell bottom. This ensures a reliable temperature measurement.

LONG LIFE, LOW MAINTENANCE

The use of protective sheathing and wells increases the life of the sensor while ensuring low heat loss and suitable thermal response. When wells are used, the spring-loaded RTD can be easily removed without process shutdown. Longer sensor life results in lower maintenance costs and reduced spare parts inventory.

MANY AGENCY APPROVALS/CERTIFICATIONS

Approved/Certified by FM, FMc, and CSA for Explosionproof locations; and certified for Flameproof locations by ATEX and IECEx.

PERFORMANCE SPECIFICATIONS

Accuracy

ASTM-A Calibration Sensors

$\pm 0.13 + 0.0017(T)^{\circ}\text{C}$, where T = $^{\circ}\text{C}$ temperature, absolute value. (Better than IEC-A calibration accuracy.)

ASTM-B Calibration Sensors

$\pm 0.25 + 0.0042(T)^{\circ}\text{C}$, where T = $^{\circ}\text{C}$ temperature, absolute value. (Better than DIN and IEC-B calibration accuracy.)

Reproducibility

$\pm 0.125^{\circ}\text{C}$ ($\pm 0.25^{\circ}\text{F}$) for 480°C (900°F) and below;
 $\pm 0.25^{\circ}\text{C}$ ($\pm 0.5^{\circ}\text{F}$) for above 480°C (900°F).

Operational Stability

Less than $\pm 0.06^{\circ}\text{C}$ ($\pm 0.1^{\circ}\text{F}$) shift from initial calibration in one year.

Response Time

5 seconds maximum for a 63% recovery; based on a step change in temperature of the bare sensor starting at an ambient room temperature of 25°C (77°F) to being immersed in 100°F (212°F) water stirred at 1 m/s (3 ft/s).

FUNCTIONAL SPECIFICATIONS

Temperature Limits

The minimum and maximum temperature limits for the RTD element, sheaths, and connection head are given below. It is assumed that process temperature determines element and sheath temperature. The user should take into account that a combination of ambient and process temperature may affect connection head temperature, depending on the thermal environment of the installation.

ELEMENT

-200 and +650°C (-330 and +1200°F)

CONNECTION HEAD

-40 and +105°C (-40 and +220°F)

316 ss SHEATH

-200 and +480°C (-320 and +900°F)

INCONEL SHEATH

-200 and +650°C (-320 and +1200°F)

Vibration

A detector, with 76 mm (3 in) of its sheathed length unsupported or overhanging, will withstand 250 m/s² (25 "g") vibration from 20 to 2000 Hz in any axis for 25 minutes without damage.

External Pressure

The detector sheath can be exposed to an external pressure of 21 MPa (3000 psi) without a change in resistance of more than the amount equivalent to 0.05°C (0.1°F). There will be no permanent change in the resistance at the ice point after this exposure.

ASTM Calibration

Per ASTM E1137-87. Resistance at 0°C (32°F) is as follows (also conform to DIN and IEC calibrations):

- ▶ for ASTM-B, 100.00 ± 0.10 Ω
- ▶ for ASTM-A, 100.00 ± 0.05 Ω

Refer to TI 005-028. Alpha is 0.00385 Ω/Ω/°C.

PHYSICAL SPECIFICATIONS

RTD Configurations

Three configurations are offered as shown in Figure 1: a well-type assembly with a nipple coupler; a well-type assembly with a nipple and union coupler; and a bare element-type assembly. The bare element-type assembly has a hex-head nipple with 1/2 NPT external thread welded on sensor for process mounting and mounting to connection head. Single or dual elements are available.

Sensor Type

Thin-film platinum resistance temperature sensor, strain free, fully annealed sheath, with three-lead configuration. Four-wire RTDs are available on request.

Sensor Wires

Three 30 cm (12") leads are color coded white, and two red. White for the one leg of the detector, and the two reds for the two legs to the other side of the detector. Stranded 0.50 mm² or 22 AWG wire with PTFE insulation.

Sensitive Length

40 mm (1.6 in) minimum, measured from closed end.

Internal Insulation

Glass fiber over sensitive length, high-purity aluminum oxide powder packed over remaining length.

Sheath Sealant

Epoxy compound applied at open end of sheath to prevent entry of moisture.

Sheath Outside Diameter (O.D.)

6.35 mm (0.250 in). Note that a well inside diameter (I.D.) of 6.60 mm (0.260 in) is required.

Insertion Length

Refer to "MODEL CODE" on page 8.

Construction

All welded and moisture sealed. 316 ss for temperatures up to 480°C (900°F), Inconel 600 for temperatures up to 650°C (1200°F).

Figure 1. PR Series RTD Configurations

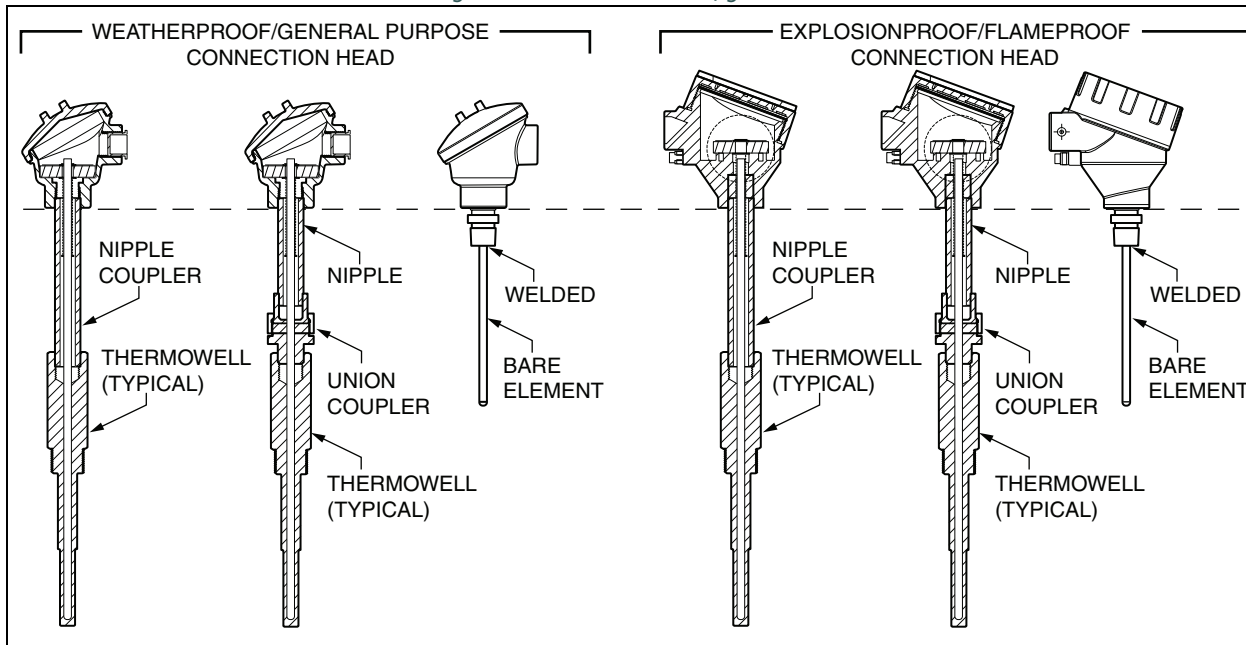

PHYSICAL SPECIFICATIONS

Weatherproof/General Purpose Connection Head

When used with a thermowell, this connection head contains a compression spring to maintain RTD tip contact. The housing is constructed from a diecast aluminum alloy and has an O-ring gasketed cover. A 1/2 NPT conduit connection (or optionally an M20 conduit thread adapter) is provided for field wiring to a ceramic terminal block within the connection head. The assembly meets IEC IP65 and provides the environmental protection of NEMA Type 4. See Figure 1.

Explosionproof/Flameproof Connection Head

This connection head is used to protect conductors in conduit systems within hazardous areas. The head contains a compression spring to maintain RTD tip contact. The housing is constructed from a diecast low copper aluminum alloy, painted, and has an O-ring gasketed cover. A 1/2 NPT conduit connection is provided for field wiring to a ceramic terminal block within the connection head. The assembly meets IP65 and provides the environmental and corrosion resistance protection of NEMA Type 4X. See Figure 1.

Thermowells

Foxboro wells isolate the process and separate the temperature-measuring sensitive portion of the RTD from potentially corrosive or damaging process media. These wells permit ready removal of the sensor without process shutdown. A selection of plain or lagged, threaded or flanged, solid, welded or tapered wells is available in a variety of sizes and materials. The wells are machined from industry standard 316 ss, and a polished finish assures maximum corrosion resistance. They are manufactured in accordance with applicable ASME, ASTM, and ANSI standards. Refer to PSS 3-3D1 A for T-Series Wells, and to PSS 3-3C1 A for W-Series Wells. Figure 2 shows typical W-Series and T-Series thermowells.

Figure 2. Typical W-Series and T-Series Wells

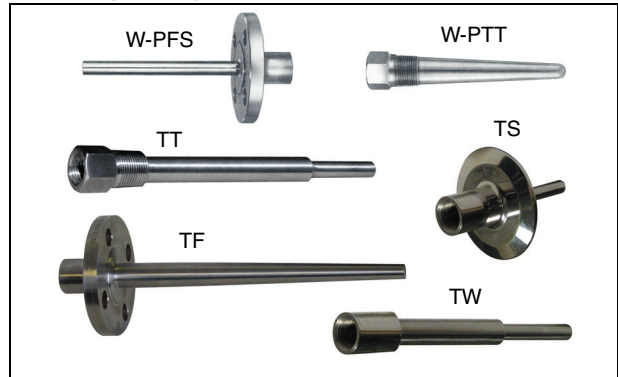

Terminal Block

A terminal block is located within the connection head. Field wires enter through the 1/2 NPT conduit connection (or optional M20 conduit thread adapter) in the head and terminate under screw terminals on the block. The terminal block accommodates either a single or dual element sensor.

Figure 3. Terminal Block Configuration

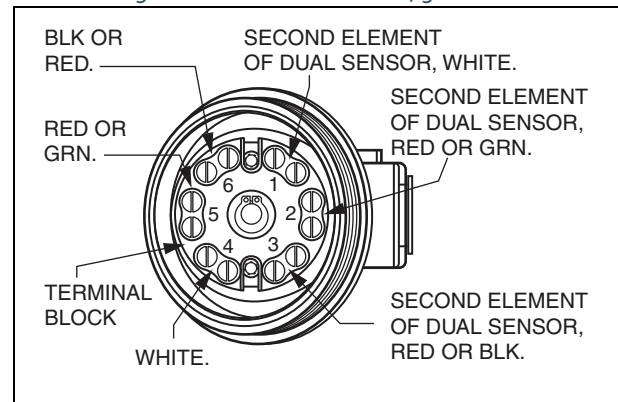

Dimensions

See "DIMENSIONS – NOMINAL" on page 10.

PRODUCT SAFETY SPECIFICATIONS

These RTDs have been designed to meet the product safety descriptions listed below. For detailed information, or status of testing laboratory approvals/certifications, contact Invensys.

| Testing Laboratory, Types of Protection, and Area Classification | Application Conditions(a) | Connection Head Code (a) |
|--|--|---------------------------------|
| FM and FMc explosionproof for Class I, Division 1, Groups B, C, and D; Dust-ignitionproof for Class II, Division 1, Groups E, F, and G; and Class III, Division 1. | Temperature Class T5; Ta = -50 to +85°C | 4 |
| CSA explosionproof for Class I, Division 1, Groups B, C, and D; Dust-ignitionproof for Class II, Division 1, Groups E, F, and G; and Class III, Division 1. | Temperature Class T5; Ta = -40 to +85°C | 5 |
| ATEX flameproof; II 1/2 G, Ex d IIC; or II 2 G, Ex d IIC; or II 2 D. | Construction Types N, P, W, and B only. Temperature Class: ▶ T5 (100°C), Ta = -40 to +85°C ▶ T6 (85°C), Ta = -40 to +75°C | 6 |
| IECEX flameproof; Ex d IIC | Construction Types N, P, W, and B only. Temperature Class: ▶ T5, Ta = -40 to +85°C ▶ T6, Ta = -40 to +75°C | 7 |

(a) Refer to "MODEL CODE" for descriptions of Construction Codes and Certifications Codes

OPTIONAL SELECTIONS AND ACCESSORIES

Accessory: Platinum Replacement Element Assemblies

To order a replacement element assembly, specify Connection Head type R. To order a replacement element assembly with a bare element, specify Construction type B; for use with a thermowell, specify Construction type E.

Accessory: RTD to Instrument Cable

The RTD to Instrument cable is a three-wire, stranded copper, 1.0 mm² or 18 AWG cable. Polyethylene insulation is 8.4 mm (0.33 in). Temperature limit is 90°C (195°F). Specify Part Number R0101LY and desired length.

Option -A3: Metric Conduit Thread Adapter

An 1/2 NPT to M20 x 1.5 metric conduit thread adapter is provided for Connection Head types 6 and 7. Select Option -A3.

Option -C1: Calibration

A 3-point RTD calibration is carried out to standard or high temperature calibration curves. Select Option -C1.

For certification of calibration, also select Auxiliary Specification Cert C.

Option -C5: Oxygen Service

The RTD is cleaned and prepared for Oxygen Service. Select Option -C5.

For certification of cleaning, also select Auxiliary Specification Cert G.

Option -W: Shipped Without Thermowell

When the -W option is ordered in conjunction with an Explosionproof or Flameproof Connection Head selection, the standard explosionproof assembly will be provided without the agency certification markings. Because the thermowell is not installed in the factory, hazardous area compliance cannot be assured. Therefore the data plate will be devoid of any hazardous area markings.

Option -WF: Wake Frequency Calculations

Wake Frequency calculations are often required to determine if the thermowell is strong enough to withstand the process conditions in the pipeline or vessel. "Von Karman Trail" refers to the turbulent wake which is formed as fluid flows past a thermowell. A vibration frequency is determined depending on the thermowell shank construction and the fluid velocity.

Should this frequency exceed the "natural frequency" of the thermowell, it will cause the thermowell to break off. It is therefore necessary that the thermowell selected be such that its "natural frequency" always exceeds the potential wake frequency caused by the process flow. Select Option -WF for wake frequency calculations.

MODEL CODE

| Description | Model |
|---|-------|
| Platinum RTD | PR |
| Sensor Type (a) | |
| Single Element | -1 |
| Dual Element | -2 |
| Connection Head (a) | |
| Weatherproof/General Purpose | 3 |
| Explosionproof and Weatherproof, FM and FMc Approvals (b) | 4 |
| Explosionproof and Weatherproof, CSA Certification (b) | 5 |
| Flameproof and Weatherproof, ATEX Certification (b) (c) | 6 |
| Flameproof and Weatherproof, IECEx Certification (b) (c) | 7 |
| Replacement Sensor (No Connection Head) (d) | R |
| Construction (a) | |
| Well Type, Nipple Coupler, steel (for connection to Well) (e) | N |
| Well Type, Nipple Coupler, 316 ss (for connection to Well) (e) | P |
| Well Type, Union Coupler, steel (for connection to Well) (c) (e) | U |
| Well Type, Union Coupler, 316 ss (for connection to Well) (e) | W |
| Bare Element with 316Lss threaded hex fitting (1/2 NPT external thread) welded on to sensor (f) | B |
| None; Replacement Sensor for use with Thermowell (g) | E |
| Calibration Curve (h) | |
| ASTM-B (Standard - same as DIN and IEC-B calibration curves) | B |
| ASTM-A (High Accuracy selection; same as IEC-A calibration curve) | A |
| Sheath - 6.35 mm (0.25 in) O.D. | |
| 316 ss | S |
| Inconel | I |
| Length "U" or "U + T" Dimension (i) | |
| 51 mm (2.0 in) | -002 |
| 76 mm (3.0 in) | -00A |
| 90 mm (3.5 in) | -003 |
| 102 mm (4 in) | -004 |
| 127 mm (5 in) | -005 |
| 152 mm (6 in) | -006 |
| 178 mm (7 in) | -007 |
| 203 mm (8 in) | -008 |
| 229 mm (9 in) | -009 |
| 254 mm (10 in) | -010 |
| 279 mm (11 in) | -011 |
| 305 mm (12 in) | -012 |
| 330 mm (13 in) | -013 |
| 356 mm (14 in) | -014 |
| 381 mm (15 in) | -015 |
| 406 mm (16 in) | -016 |
| 432 mm (17 in) | -017 |
| 457 mm (18 in) | -018 |
| 483 mm (19 in) | -019 |
| 508 mm (20 in) | -020 |

MODEL CODE (CONTINUED)

| Description | Model |
|--|-------|
| Length “U” or “U & T” Dimension (Cont.) (i) | |
| 533 mm (21 in) | -021 |
| 559 mm (22 in) | -022 |
| 584 mm (23 in) | -023 |
| 610 mm (24 in) | -024 |
| 635 mm (25 in) | -025 |
| 660 mm (26 in) | -026 |
| 686 mm (27 in) | -027 |
| 711 mm (28 in) | -028 |
| 737 mm (29 in) | -029 |
| 762 mm (30 in) | -030 |
| 787 mm (31 in) | -031 |
| 813 mm (32 in) | -032 |
| 838 mm (33 in) | -033 |
| 864 mm (34 in) | -034 |
| 889 mm (35 in) | -035 |
| 914 mm (36 in) | -036 |
| Nonstandard length are whole inches from 37 through 300 inches; specify desired length by substituting numerical values for Xs; e.g., -048 = 48 inches | -XXX |
| Optional Selections | |
| Sensor Length 0.5 in longer than the specified length; not available with Length Codes 00A or 003 | -H |
| Shipped without Thermowell; for customer to install thermowell (j) | -W |
| Thermowell other than the Standard T-Series Wells | -X |
| Wake Frequency Calculation (k) | -WF |
| Other Options | |
| Metric Conduit Thread Adapter (1/2 NPT by M20 X 1.5) (l) | -A3 |
| Three Point Calibration with Certificate | -C1 |
| Cleaned and Prepared for Oxygen Service (m) | -C5 |
| Examples: PR-13NBS-012-C1; PR-16BS-024-A3C1 | |

- (a) See Figure 1 and “DIMENSIONS – NOMINAL” on page 10 for RTD assembly configurations.
- (b) Thermowells for Explosionproof/Flameproof atmospheres are only available in the following materials: carbon steel C-1018, 316 ss, 316L ss, 304 ss, 304L ss, Alloy 20 Cb-3, nickel alloy equivalent to Hastelloy® B, nickel alloy equivalent to Hastelloy® C-276, Inconel™ 600, R-Monel™ 405, K-Monel™ 500, Nickel 200, Titanium, and Cr/Moly steels. Hastelloy is a registered trademark of Haynes International, Inc.
- (c) ATEX and IECEx, d, not available with Construction Code U, carbon steel union coupler.
- (d) Use only with Construction Codes B or E.
- (e) For Well Type construction, the well must be specified separately. Refer to “PHYSICAL SPECIFICATIONS” on page 4.
- (f) Use for Bare Sensor replacement when Connection Head selection R is used.
- (g) Use only with Connection Head selection R. Used for replacement of sensors for construction codes N, P, U and W.
- (h) See “PERFORMANCE SPECIFICATIONS” on page 2 for Calibration Curve Accuracy.
- (i) With a bare sheath assembly, the “U” or “U + T” dimension is identified as the “A” dimension. See “DIMENSIONS – NOMINAL” on page 10.
- (j) No Agency electrical safety certifications apply.
- (k) Not available with Construction B (Bare Element). Requires completed data sheet, available to download at http://iom.invensys.com/EN/pdfLibrary/Datasheet_Foxboro_ThermowellWakeFrequency_04-11.pdf.
- (l) Option -A3 is only available with Connection Head Codes 6 and 7.
- (m) Customer is responsible for cleaning of customer supplied thermowells. For certification of cleaning, select Auxiliary Specification Cert G.

DIMENSIONS – NOMINAL

mm
in

WEATHERPROOF/GENERAL PURPOSE CONNECTION HEAD

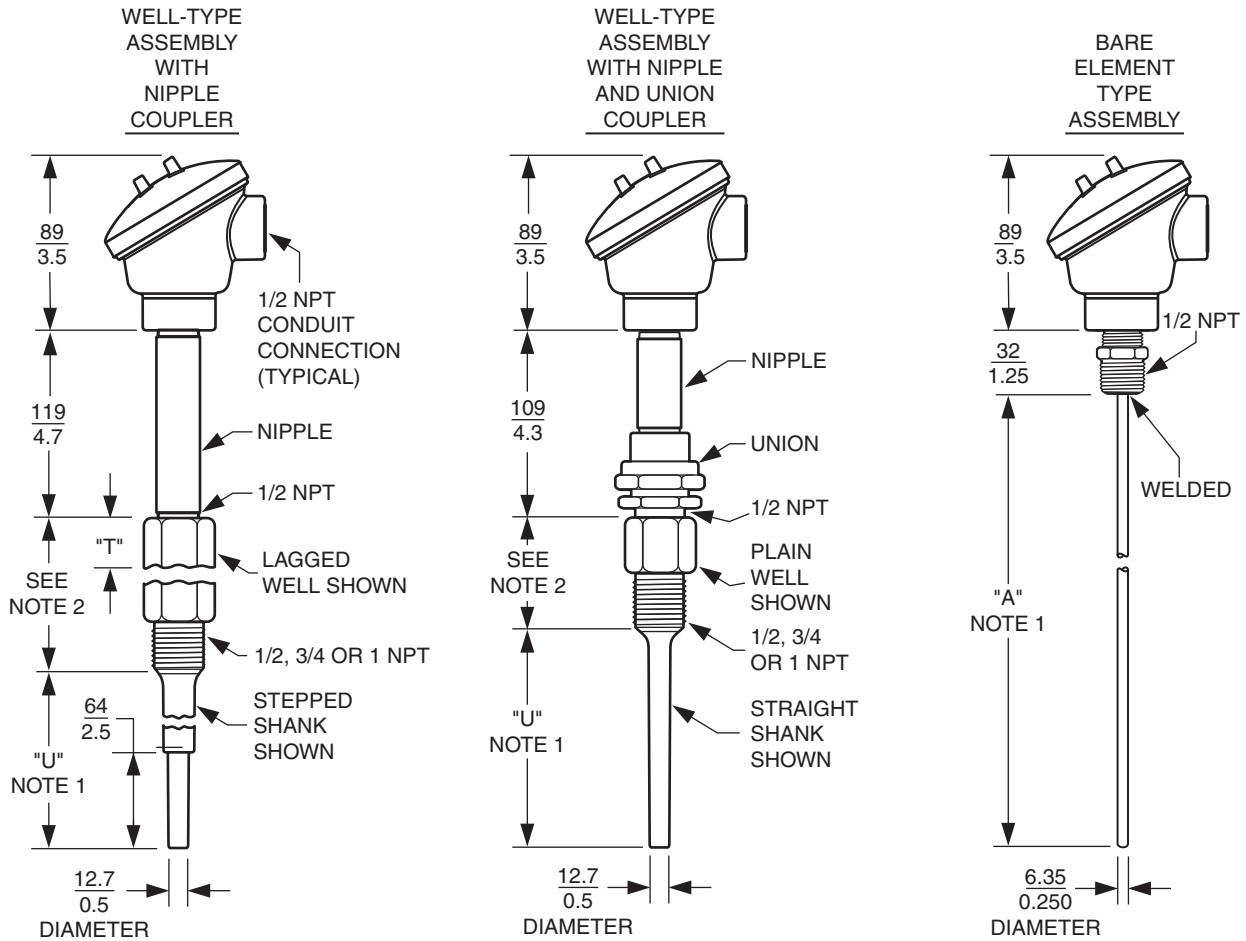

NOTES

1. U = Insertion Length (with well); and A = Bare Sensor Length (without well).
2. A lagged well has a lagging length, T, that is in addition to the length of a plain well, as shown in the two well-type assembly illustrations. The dimension indicated varies depending on the lagging length. This dimension without lagging is nominally 51 mm (2.0 in). For a lagged well, the nominal dimension is 51 mm (2.0 in) plus lagging length T.

mm
in

EXPLOSIONPROOF/FLAMEPROOF CONNECTION HEAD

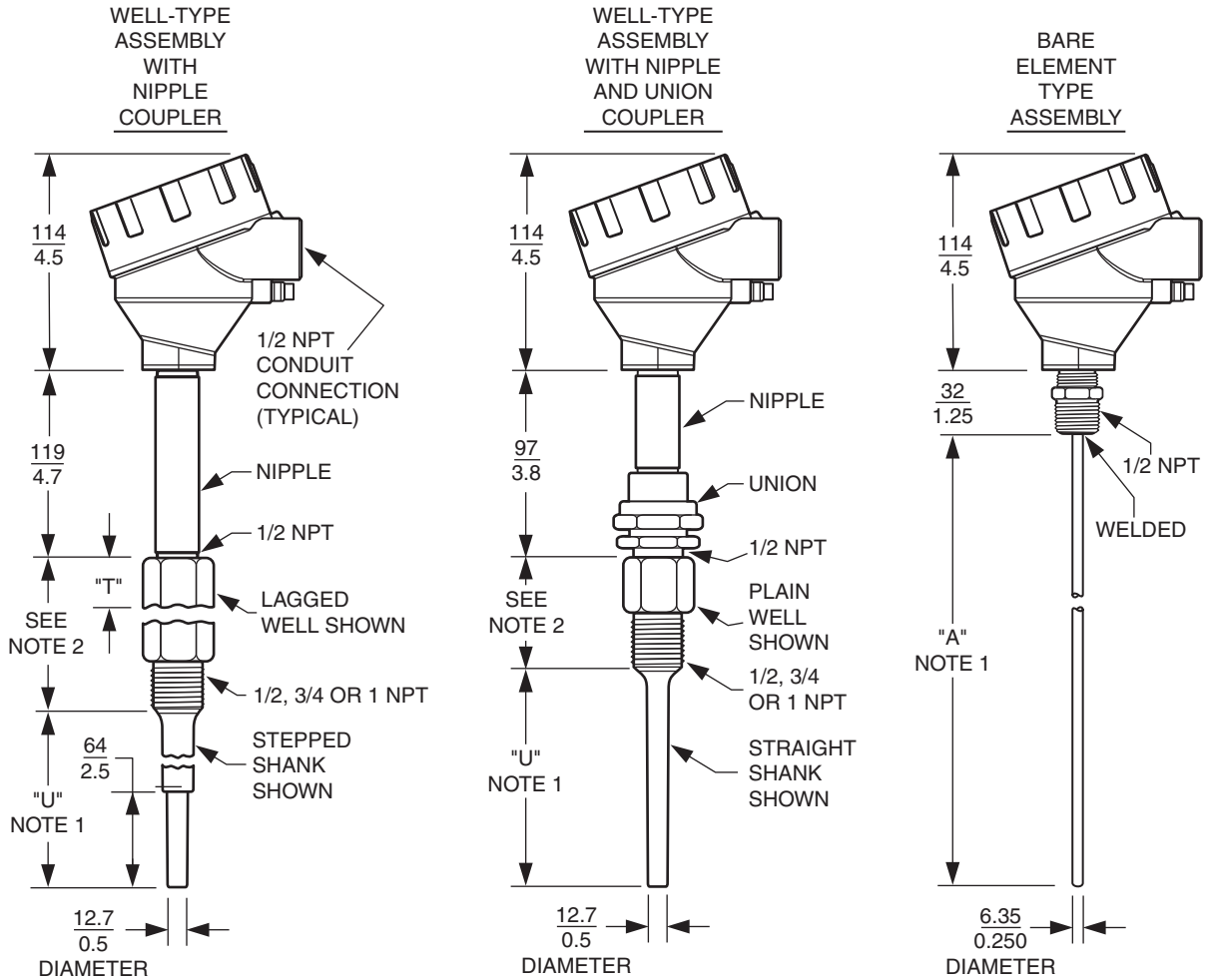

NOTES

1. U = Insertion Length (with well); and A = Bare Sensor Length (without well).
2. A lagged well has a lagging length, T, that is in addition to the length of a plain well, as shown in the two well-type assembly illustrations. The dimension indicated varies depending on the lagging length. This dimension without lagging is nominally 51 mm (2.0 in). For a lagged well, the nominal dimension is 51 mm (2.0 in) plus lagging length T.

ORDERING INSTRUCTIONS

1. Model Number
2. Thermowell, if required:
For "T" Series Wells, see PSS 3-3D1 A
For "W" Series Wells, see PSS 3-3C1 A
3. Accessories
4. User Tag Data

OTHER FOXBORO TEMPERATURE MEASUREMENT SENSORS

PSS 1-1B6 A MT Series MINOX™ Thermocouples
PSS 3-3A1 A Filled Thermal Systems

OTHER M&I PRODUCTS

Invensys provides a broad range of measurement and instrument products, including solutions for pressure, flow, analytical, positioners, temperature, controlling and recording. For a listing of these offerings, visit our web site at:

www.invensys.com