

MT Series MINOX™ Thermocouples

Style B

Introduction

The MT Series Thermocouple consists of a sensitive measuring junction surrounded by a magnesium oxide insulation and enclosed in a metal sheath. They are available in ISA Type K, N, J, E, and T, each having its own temperature range. The MT Series Thermocouples are either single or dual element and have either a general purpose or explosionproof connection head.

The model with a bare element construction (MT-##B) comes with a bushing for direct mounting to the process vessel. The MT-##N, MT-##P, MT-##U, and MT-##W models are designed for mounting in a well. A spring-loaded device keeps the element tip pressed against the bottom of the well. This improves thermal response time and minimizes the effects of shock and vibration.

Warnings

—  **WARNING** —

Thermocouple must be installed to meet all applicable local installation regulations, such as hazardous location requirements and electrical wiring codes. Persons involved in the installation must be trained in these code requirements.

Thermocouple Identification

The following information about your thermocouple is located on the data plate attached to its connection head. A sample data plate is shown in Figure 1.

A: Certification Number

B: Electrical Certification

C: Environmental Protection (NEMA Type or IEC designation)

D: Model Number. (see PL 008-108 for a complete explanation of the code)

E: Origin Code (area of manufacture and year and week of manufacture)

F: Model Style

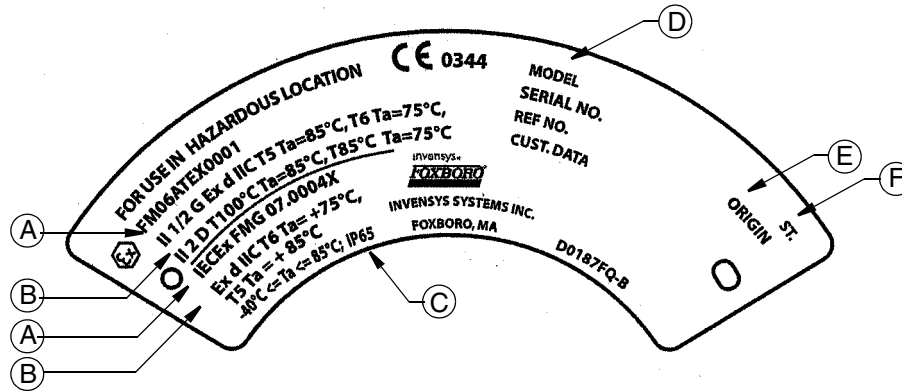

Figure 1. Sample Thermocouple Identification

Standard Specifications

Sheath Temperature Limits

316 Stainless Steel: -200 and +870°C (-320 and +1600°F)

Inconel: -200 and +1150°C (-320 and +2100°F)

Length ('U'+ 'T') for well type or 'A' for bare sensor type)

90 mm (3.5 in) through 915 mm (36 in) in 12.7 mm (0.5 in) increments

Minimum Immersion: 90 mm (3.5 in)

Connection Head: Meets IEC IP65 and provides the environmental protection of NEMA Type 4.

Product Safety Specifications

The electrical certification is printed on the data plate. See Item A on the example shown in Figure 1. It is also included as part of the model code (Item D in Figure 1). See the following example. Also see Table 1.

MT-16UKIS-008
 CONNECTION HEAD AND CERTIFICATION

where: 3 = Weatherproof, General Purpose

4 = Explosionproof, FM and FMc

5 = Explosionproof, CSA

6 = Flameproof, ATEX

7 = Flameproof IECEx

— NOTE —

These thermocouples have been designed to meet the electrical safety descriptions listed in Table 1. For detailed information or status of testing laboratory approvals/certifications, contact Invensys Process Systems (IPS).

Table 1. Electrical Safety Specifications

Testing Laboratory, Types of Protection, and Area Classification	Application Conditions ^(a)	Connection Head Code
FM and FMc explosionproof for Class I, Division 1, Groups B, C, and D; dust-ignitionproof for Class II, Division 1, Groups E, F, and G; Class III Division 1.	Temperature Class T5. Ta = -50 to +85°C.	4
CSA explosionproof for Class I, Division 1, Groups B, C, and D; dust-ignitionproof for Class II, Division 1, Groups E, F, and G; Class III Division 1.	Temperature Class T5. Ta = -40 to +85°C.	5
ATEX flameproof; II 1/2 G Ex d IIC or II 2 G Ex d IIC or II 2 D	FM06ATEX0001 Construction Types N, P, W, and B only. Temperature Class T6 (T85°C) Ta = -40 to +75°C. T5 (T100°C) Ta = -40 to +85°C.	6
IECEX flameproof; Ex d IIC	IECEX FMG 07.0004X Construction Types N, P, W, and B only. Temperature Class T6; Ta = -40 to +75°C. T5; Ta = -40 to +85°C.	7

(a) Only approved if assembled with thermowell at the factory.

Installation

— WARNING —

In applications where a thermocouple is installed in a closed vessel under pressure or in an open vessel below the surface of the fluid, the thermocouple must **not** be removed during process operation unless it is installed in a thermowell.

Well Type, Nipple or Union Coupler (MT-##N, P, U, W)

When the thermocouple and thermowell are purchased together, they are fully assembled. The only mechanical assembly required is to install the thermowell into the process vessel. If the thermocouple is purchased without a thermowell, it is also necessary to insert the thermocouple into the thermowell and connect the nipple or union coupler to the well.

— CAUTION —

When inserting an thermocouple into an existing thermowell, make sure that the internal depth of the well is correct for use with the thermocouple. The sensor sheath should contact the bottom of the well for proper thermal response time. However, if the internal depth of the well is too short, the thermocouple can be damaged if

insertion exceeds the range of the spring that holds the sheath in contact with the bottom of the well.

When installing a thermocouple with a lagging well into an insulated vessel, add insulation after installation of the thermocouple to avoid error due to heat radiation. Refer to Figure 2.

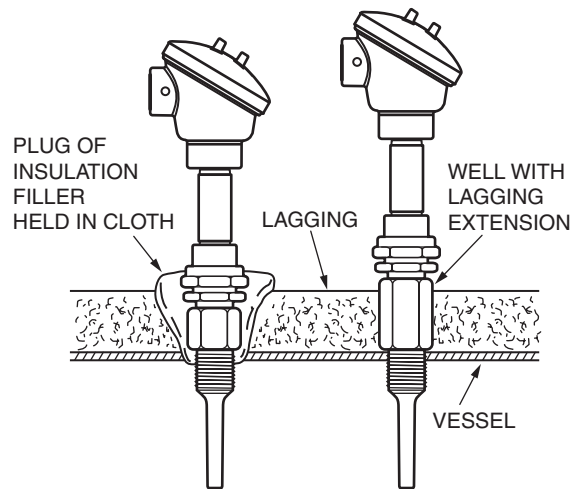

Figure 2. Installation of a Lagging Well Into an Insulated Vessel

Bare Element Assembly (MT-##B)

Three types of couplers are available for connecting a bare element assembly to the process vessel.

Compression Coupler

This coupler is for permanently setting the insertion (U) length. It contains an internally mounted ferrule. The external thread of the bushing is 1/4 or 1/2 NPT. The material of the coupler is Brass or 316 ss. Position the bushing to the desired point on the sensor sheath and tighten the compression nut.

—  **CAUTION** —

Once the compression coupler has been tightened onto the thermocouple sheath, it cannot be relocated.

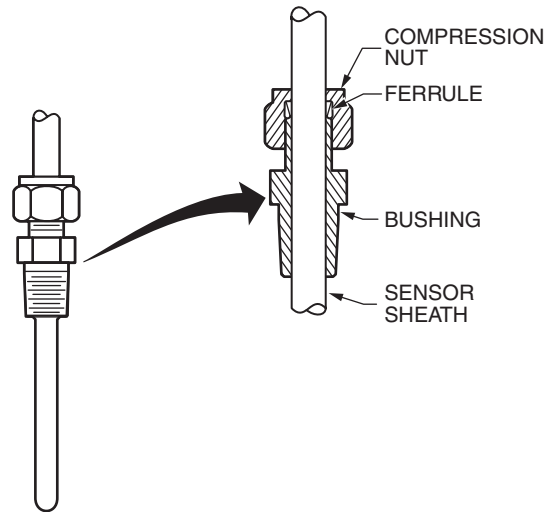

Figure 3. Compression Coupler

Spring-Loaded Coupler

This coupler is for use with a bare element assembly installed in a well. It provides for spring-loading the sensor sheath against the bottom of the well. The jam nut thread is 1/2 or 3/4 NPT. The material of the coupler is cadmium-plated carbon steel. Referring to Figure 4, install the thermocouple using this coupler as follows:

1. Insert the sensor sheath into the thermowell and press down firmly. Pencil mark the sheath at the location where the jam nut first engages the well threads,
2. Remove the thermocouple. With the jam nut and spring sliding freely on the upper portion of the sheath, install the split nut so that the upper edge of the nut is at the marked location.
3. Reinsert the sensor sheath into the thermowell. Tighten the jam nut with moderate force to ensure firm seating of the sheath against the bottom of the well.

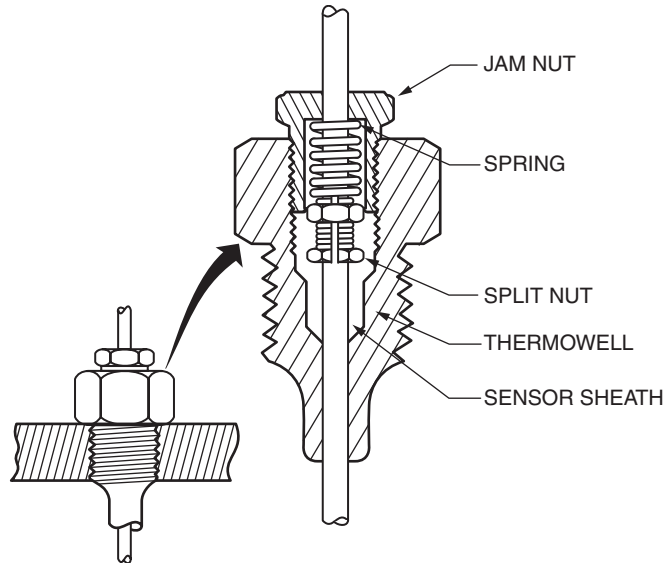

Figure 4. Spring-Loaded Coupler

Packing-Gland Coupler

This coupler is for setting the insertion (U) length. It differs from the compression coupler in that it may be reset. The external thread of the bushing is 1/2, 3/4, or 1 NPT. Referring to Figure 5, install the thermocouple using this coupler as follows:

1. Install the bushing into the process vessel or thermowell.
2. Moderately tighten the jam nut.
3. Loosen the gland nut and slide the sensor sheath to the desired position.
4. Tighten the gland nut to secure the thermocouple in place.

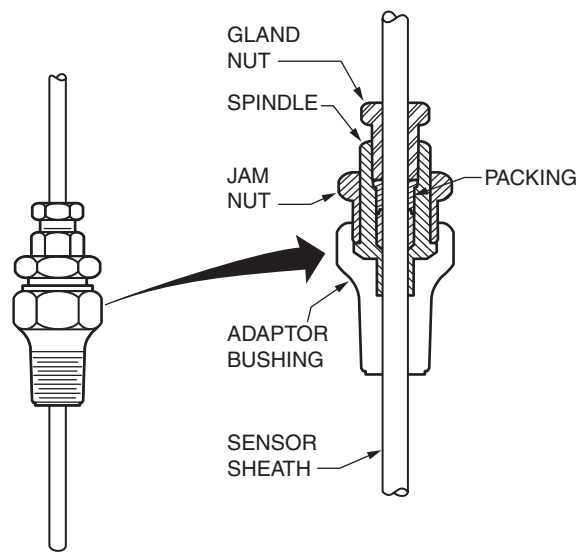

Figure 5. Packing-Gland Coupler

Wiring

— **⚠ CAUTION** —
 Run thermocouple external connecting wiring entirely independent of other wiring in a separate conduit isolated from earth (ground) and situated so that water or other fluids cannot enter the conduit to cause leakage currents, short circuits, or earthing (grounding). Do **not** run power wires in the same conduit with thermocouple extension wires.

— **⚠ CAUTION** —
 Connection wiring material must be able to withstand temperatures up to 85°C.

— **⚠ CAUTION** —
 To protect the thermocouple assembly from vibration and strain, do not connect rigid conduit to the connection head. Use flexible conduit if a conduit connection is required.

Connect external wiring to terminal board in connection head per Figure 6.

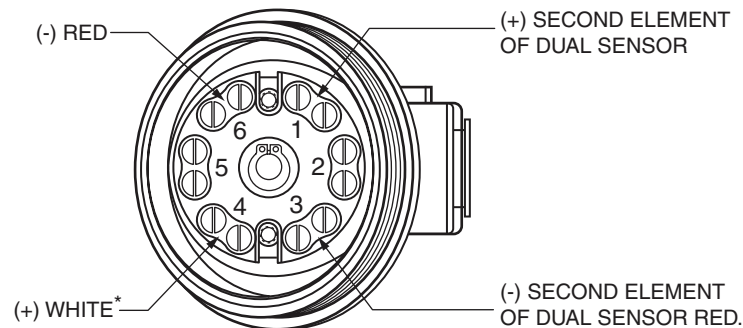

*OR BLUE, PURPLE, YELLOW, OR ORANGE

Figure 6. External Wiring Connections

Cover Lock

A cover lock, shown in Figure 7, is provided as standard with ATEX certified thermocouples. To lock the cover, screw the cover onto the housing as far as possible and then screw the set screw into place. Make sure that the set screw is located between any two of the eight small tabs on the cover.

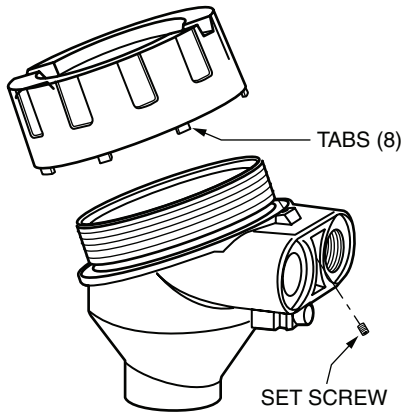

Figure 7. Cover Lock

Sensor Replacement

Well Type, Nipple or Union Coupler (MT-##N, P, U, W)

1. Remove the connection head cover.
2. Disconnect the field and sensor wiring from the terminal board.
3. Remove the terminal board screws and withdraw the terminal board and sensor.

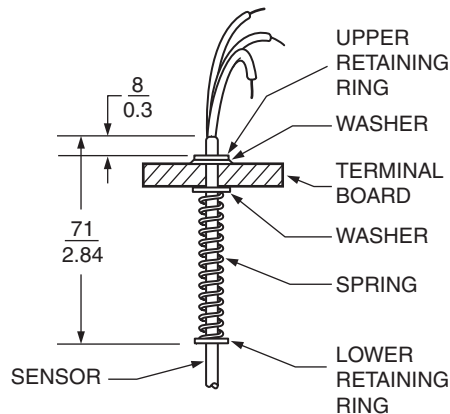

Figure 8. Sensor/Terminal Board Assembly

4. Using retaining ring pliers, remove the upper retaining ring. Slide the terminal board, spring, and washers off of the sensor. Remove the lower retaining ring.
5. Install lower retaining ring on the sheath of the new thermocouple at the dimension shown in Figure 8.
6. Slide the spring, washer, terminal board, and second washer onto the sensor.
7. Install upper retaining ring on the sheath of the new thermocouple at the dimension shown in Figure 8.
8. Insert the sensor through the connection head into the thermowell.

9. Fasten the terminal board in place using the two screws removed in Step 3.
10. Reconnect the field and sensor wiring disconnected in Step 2. Refer to “Wiring” on page 7.
11. Reinstall the connection head cover.

Bare Element Assembly (MT-##B)

1. Remove the connection head cover.
2. Disconnect the field and sensor wiring from the terminal board.
3. Unscrew and remove the sensor from the connection head.
4. Insert the wires of the new sensor through the bottom port of the connection head and screw the sensor into the connection head.
5. Reconnect the field and sensor wiring disconnected in Step 2. Refer to “Wiring” on page 7.
6. Reinstall the connection head cover.

ISSUE DATES

JUL 1984
OCT 2005
JUN 2006
JAN 2007
JAN 2008
SEP 2009

Vertical lines to the right of text or illustrations indicate areas changed at last issue date.



IPS Corporate Headquarters
5601 Granite Parkway Suite 1000
Plano, TX 75024
www.ips.invensys.com

Foxboro Global Client Support
Inside U.S.: 1-866-746-6477
Outside U.S.: 1-508-549-2424 or
contact your local Foxboro
representative.
Facsimile: 1-508-549-4999

Invensys, Foxboro, and IPS Logo are trademarks of Invensys plc,
its subsidiaries, and affiliates.
All other brand names may be trademarks of their respective
owners.

Copyright 1984-2009 Invensys Systems, Inc.
All rights reserved