

## SRD960 Universal Positioner – All versions –



The Universal Positioner SRD960 is designed to operate pneumatic valve actuators and is available in the version EEx d / explosionproof (flameproof) or EEx ia / intrinsic safety. It can be operated from control systems (e.g. the Foxboro I/A Series System), controllers, or PC-based configuration- and operation tools such as PC20 / PC50 (FDT-Software). The positioner is available with different communication protocols. This includes versions with analog setpoint (4 to 20 mA) without communication or with superimposed HART signal; digital with FoxCom protocol, or fieldbus communication according to PROFIBUS-PA and FOUNDATION Fieldbus H1 based on IEC 1158-2 MBP acc. to FISCO. The multi-lingual full text graphic-LCD in connection with the external 4 push buttons allows a comfortable and easy local configuration and operation as well as the display of valve specific data, and status- and diagnostic messages.

### DEVICE FEATURES

#### Intelligent

- Auto-start with self-calibration
- Self diagnostics, status- and diagnostic messages
- Easy operation with four key pads
- Multi-Lingual full text graphical LCD, or LEDs

#### with communication

- HART, FOUNDATION Fieldbus H1, PROFIBUS-PA, FoxCom
- Configuration by means of local keys, hand-held terminal (HART), PC or I/A Series system or with a infrared interface by means of IRCOM

### COMMON FEATURES

- Stroke 8 to 120 mm / 260 mm (0.3 to 4.7 in / 10.2 in)
- Angle range up to 95 °
- Supply air pressure up to 6 bar (90 psig), with spool valve up to 7 bar (105 psig)
- Single or double-acting
- Mounting on linear actuators according to NAMUR – IEC 534, Part 6 – VDI/VDE 3847
- Mounting on rotary actuators acc. to VDI/VDE 3845
- Protection class IP 65, NEMA 4X
- Explosion protection:  
Flameproof according to ATEX - EEx d  
Explosion proof according to FM

**LABELS**

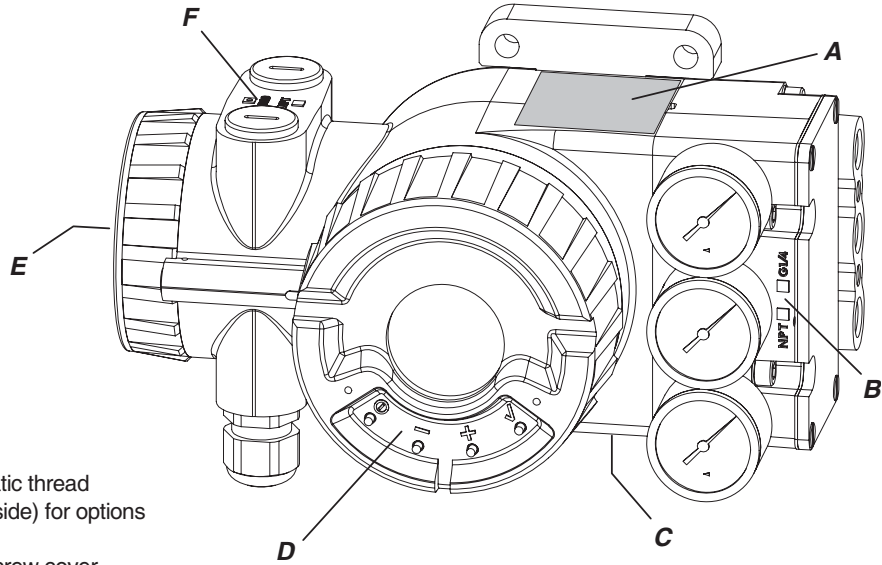

- A** Nameplate
- B** Designation of pneumatic thread
- C** Additional label (underside) for options
- D** Designation of keys
- E** Warning label on the screw cover
- F** Designation of electrical connection threads

**Nameplate A** (Example)  
Without Ex protection

<b>ECKARDT</b>		REV. <input type="checkbox"/>						
SRD960-		ZUSÄTZLICHE EIN- / AUSGÄNGE ADDITIONAL INPUTS / OUTPUTS						
ZULUFT / SUPPLY : max. / bar / psi		BINÄRAUSGÄNGE BINARY OUTPUTS						
<input type="checkbox"/> EINFACH / SINGLE	<input type="checkbox"/> DOPPELT / DOUBLE	<table border="1"> <thead> <tr> <th>KANAL CHANNEL</th> <th>KLEMMEN TERMINAL</th> </tr> </thead> <tbody> <tr> <td>1</td> <td>81 82</td> </tr> <tr> <td>2</td> <td>83 84</td> </tr> </tbody> </table>	KANAL CHANNEL	KLEMMEN TERMINAL	1	81 82	2	83 84
KANAL CHANNEL	KLEMMEN TERMINAL							
1	81 82							
2	83 84							
<input type="checkbox"/> 4...20 mA <input type="checkbox"/> PROFIBUS PA <input type="checkbox"/> HART <input type="checkbox"/> FOXCOM IT2 <input type="checkbox"/> FF-Fieldbus H1								
	Tu -40°C ... +80°C	Made in France by Eckardt SAS, F- 68360 Soultz (1)						

SRD960- [ Device specification, Model Code ]

**Nameplate A** (Example)  
With Ex protection acc. ATEX  
Type of protection EEx d

<b>ECKARDT</b>		REV. <input type="checkbox"/>						
SRD960-		ZUSÄTZLICHE EIN- / AUSGÄNGE ADDITIONAL INPUTS / OUTPUTS						
ZULUFT / SUPPLY : max. / bar / psi		BINÄRAUSGÄNGE BINARY OUTPUTS						
<input type="checkbox"/> EINFACH / SINGLE	<input type="checkbox"/> DOPPELT / DOUBLE	<table border="1"> <thead> <tr> <th>KANAL CHANNEL</th> <th>KLEMMEN TERMINAL</th> </tr> </thead> <tbody> <tr> <td>1</td> <td>81 82</td> </tr> <tr> <td>2</td> <td>83 84</td> </tr> </tbody> </table>	KANAL CHANNEL	KLEMMEN TERMINAL	1	81 82	2	83 84
KANAL CHANNEL	KLEMMEN TERMINAL							
1	81 82							
2	83 84							
<input type="checkbox"/> 4...20 mA <input type="checkbox"/> PROFIBUS PA <input type="checkbox"/> HART <input type="checkbox"/> FOXCOM IT2 <input type="checkbox"/> FF-Fieldbus H1								
	PTB 02 ATEX 1084X TYPE AD 639 II 2 G EEx d IIB / IIC T4 / T6 U max = 42V = Tu min = -30°C Tu max = +80°C	Made in France by Eckardt SAS, F- 68360 Soultz (1)						

**Additional label C** Options (Example)

ADDITIONAL INPUTS / OUTPUTS ENTREES / SORTIES ADDITIONNELLES	
LIMIT SWITCH (INDUCTIVE CONTACTS) VALEURS LIMITES (CAPTEURS INDUCTIFS) SECURITY-VERSION VERSION SECURITE	
LS1 VL1	LS2 VL2
41 42	51 52
556729108 (1)	

**Measurement point label** (Example)  
Directly fixed or attached

XXX 09/16
-----------

**Additional manufacturing data** are stored in the software and are read via communication interface.

**TABLE OF CONTENTS**

CHAP: CONTENT	PAGE	CHAP: CONTENT	PAGE
	<b>LABELS</b> .....	<b>8</b>	<b>START-UP</b> .....
<b>0</b>	<b>SUMMARY</b>	8.1	General .....
	HART .....		Setting by means of local keys .....
	FOUNDATION Fieldbus Kommunikation ..	8.2	Operation (LCD / LED) .....
	PROFIBUS Communication .....		Operation with local keys .....
	FoxCom .....		Table: Menu structure .....
<b>1</b>	<b>METHOD OF OPERATION</b> .....	8.3	Description of menus .....
1.1	General .....	<b>9</b>	<b>DECOMMISSIONING</b> .....
1.2	Block diagram .....	<b>10</b>	<b>MAINTENANCE</b> .....
1.3	Functional description .....	10.1	Service connector and IrCom .....
<b>2</b>	<b>OPERATION MODES</b> .....	10.2	Supply filter replacement .....
<b>3</b>	<b>DESIGN - FUNCTIONAL DESIGNATIONS</b>	10.3	Pneumatic amplifier .....
3.1	Pneumatic accessories .....	10.4	Replacement of mechanical and pneumatic units:
<b>4</b>	<b>MOUNTING TO ACTUATORS</b> .....		Removal of electronics unit .....
4.1	Linear, NAMUR Mounting (left hand) .....		Option "Built-in pressure sensors" .....
4.2	Linear, NAMUR Mounting (right hand) .....		Option "Additional In-/Outputs" .....
4.3	Linear, Direct Mounting .....		Option "Limit switch" .....
4.4	Rotary actuators .....	10.5	Angle calibration .....
<b>5</b>	<b>PNEUMATIC CONNECTIONS</b> .....	<b>11</b>	<b>TROUBLE-SHOOTING GUIDE</b> .....
<b>6</b>	<b>ELECTRICAL CONNECTION</b> .....	<b>12</b>	<b>SAFETY REQUIREMENTS</b> .....
<b>7</b>	<b>OPTIONS</b> .....	<b>13</b>	<b>SYSTEM CONFIGURATION</b> .....
7.1	"Limit switch" .....		<b>DIMENSIONS</b> .....
7.2	"Additional In-/Outputs" .....		
7.3	"Built-in pressure sensors" .....		

**Installation and start-up of instrument to be carried out only by qualified personnel, familiar with installation and start-up procedures and operation of this product!**

**Accident prevention**

The connected instrument contains mechanically moving parts, e.g. feedback lever, which could cause injuries. The operators have to be instructed accordingly.

**Electrical safety**

This instrument satisfies the conditions for safety class III, overvoltage category I according to EN 61010-1 or IEC1010-1.

Any work on electrical parts must be done by qualified personnel if any supply is connected to the instrument. The instrument must be used for ist designated purpose

and connected in accordance with ist connection diagram (see page 60).

Locally applicable installation regulations for electrical equipment must be observed, e.g. in the Federal Republic of Germany DIN VDE 0100 resp. DIN VDE 0800.

The instrument must be operated with safety extra low voltage SELV or SELV-E.

Safety precautions taken in the instrument may be rendered ineffectual if the instrument is not operated in accordance with the Master Instructions.

Limitation of power supplies for fire protection must be observed due to EN 61010-1, appendix F or IEC 1010-1.

## Summary – HART Communication

Start-up according to following logical steps:

### Mounting to Actuator (Valve)

The SRD960 can be mounted to stroke or rotary actuators. More see page 13.

### Connection and Start-up

Carry out the pneumatic tubing. More see page 22. Upon connection of supply air and a voltage source of e.g. DC 12 V to the input terminals (pay attention to polarity, see page 23) an initial start-up can be carried out without any further equipment.

With the local push buttons, basic parameters can be changed such as type of actuator, side of installation, valve opens/closes with increasing setpoint value, and characteristics curve of the valve (values set ex-factory: stroke actuator, mounting side: left, valve opens with increasing setpoint value, linear characteristics curve).

Thereafter an AUTOSTART can be performed; during which the SRD960 determines independently the geometric data of the actuator as well as control parameter, to ensure an optimized operation with the attached valve.

More see page 26.

HART version:

The positioner can be operated either locally or via hand-held terminal or PC (via modem).

## System configuration

**HART version:** When using 'Communication' (an a.c. signal which modulates on the 4-20 mA signal), it must be ensured that the connected outputs, buffer amplifier and barriers are compatible with the frequency ranges used. In addition to the load, the AC impedances requirements must be met. Therefore, it is recommended that only the specified amplifier, barrier and configuration device is used. More see page 58.

To prevent crosstalk between lines and reduce disturbances through electromagnetic influences, it is recommended that twisted-pair shielded lines be used, with a diameter of AWG 22 - 14 (0,3...2,5 mm<sup>2</sup>) and a max. capacity of 100 pF/m.

The line capacities and connected devices may not exceed the maximum values listed for a particular HART protocol.

All components which are connected to the SRD in an explosion hazardous area, require an Ex-Approval. The therein applicable limit values must not be exceeded in any event. These limit values also have to be adhered to when connecting additional capacitances, inductances, voltage or current sources.

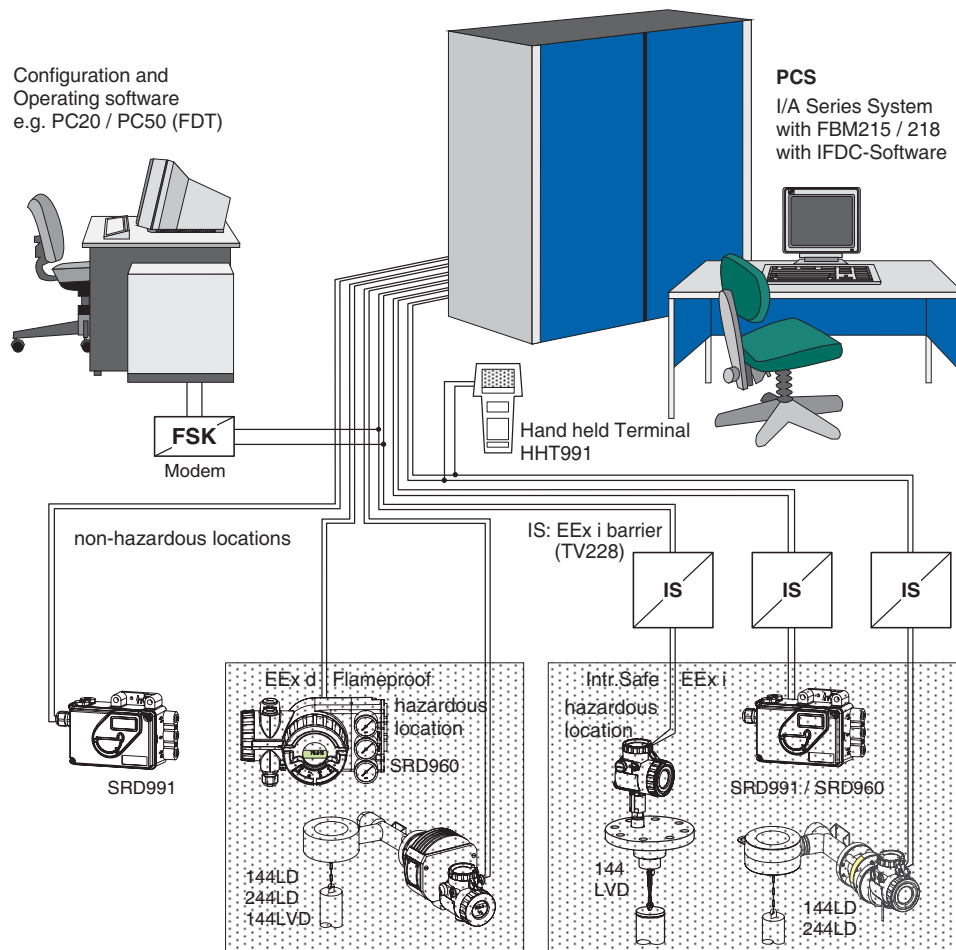

## Summary – FOUNDATION Fieldbus

Start-up according to following logical steps:

### Mounting to Actuator (Valve)

The SRD960 can be mounted to stroke or rotary actuators. More see page 13.

### Connection and Start-up

Carry out the pneumatic tubing. More see page 22. Upon connection of supply air and a voltage source of e.g. DC 24 V to the input terminals (polarity is random, see page 23) an initial start-up can be carried out without any further equipment.

With the local push buttons, basic parameters can be changed such as type of actuator, side of installation, valve opens/closes with increasing setpoint value, and characteristics curve of the valve (values set ex-factory: stroke actuator, mounting side: left, valve opens with increasing setpoint value, linear characteristics curve).

Thereafter an AUTOSTART can be performed; during which the SRD960 determines independently the geometric data of the actuator as well as control parameter, to ensure an optimized operation with the attached valve.

More see page 26.

### Bus Connection

The SRD 960 in the version FOUNDATION Fieldbus is bus compatible, which means that to a 2-core lead the instruments have to be attached parallel according to IEC 1158-2. The lead serves as voltage feeder as well as for digital communication.

A FOUNDATION Fieldbus can consist of one or several segments, each with an individual length of up to 1900 m. An Ex-barrier should not have a further distance than 100 m from a bus terminal. To a segment up to 32 instruments can be attached. A maximum of up to 240 instruments can be addressed (including repeater = connector of segments). To activate each instrument individually, an individual address has to be entered.

Ex-factory always the address 29h (41) is stored. This address can be changed automatically with the NI-Configurator.

### System Integration

With the NI-Configurator changes in the configuration of the SRD960 can be carried out. The required files (\*.FFO, \*.SYM, \*.CFF) can be downloaded from the Internet by path [http://www.foxboro-eckardt.com/products/srd960\\_en.html](http://www.foxboro-eckardt.com/products/srd960_en.html).

There a further document is made available, which explains the communication data and parameters in detail.

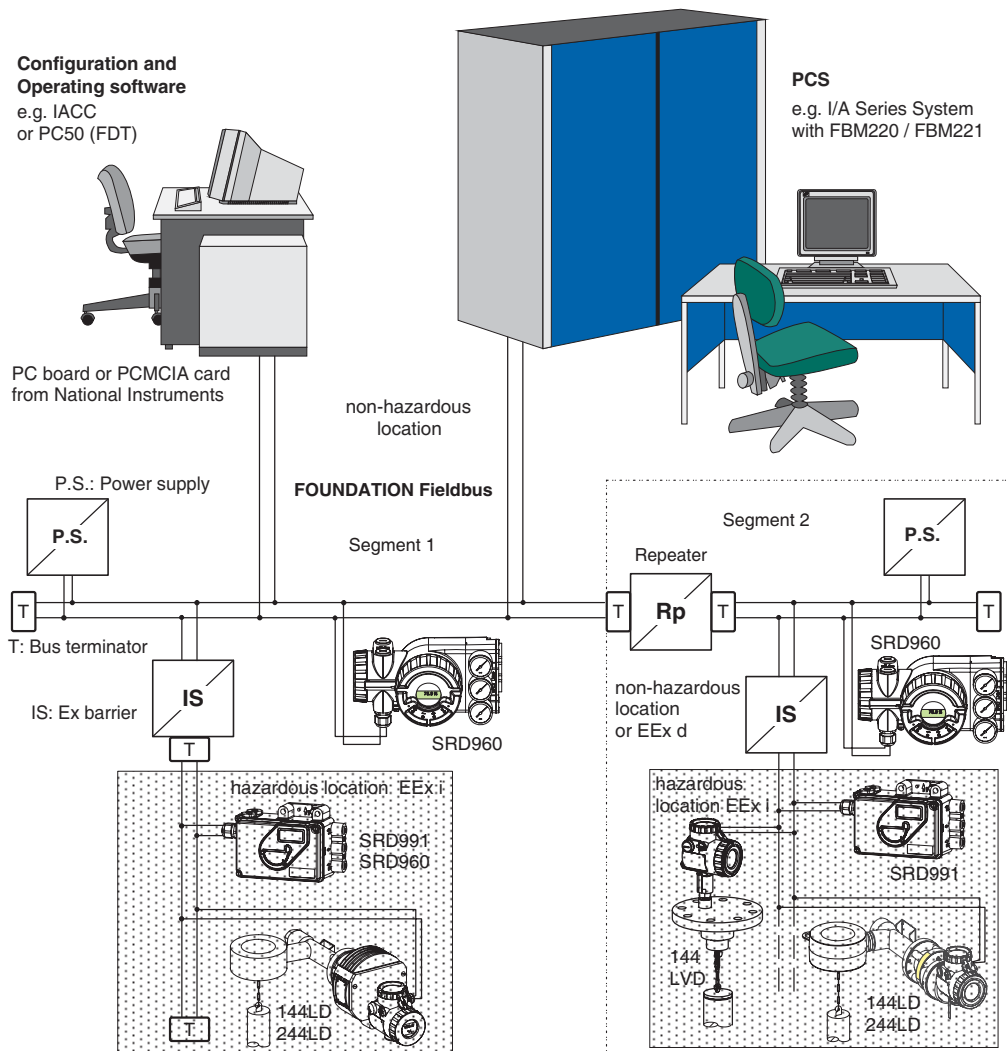

More informations about FOUNDATION Fieldbus see [www.fieldbus.org](http://www.fieldbus.org)

## Summary – PROFIBUS-PA

Start-up according to following logical steps:

### Mounting to Actuator (Valve)

The SRD960 can be mounted to stroke or rotary actuators. More see page 13.

### Connection and Start-up

Carry out the pneumatic tubing. More see page 22.

Upon connection of supply air and a voltage source of e.g. DC 24 V to the input terminals (polarity is random, see page 23) an initial start-up can be carried out without any further equipment.

With the local push buttons, basic parameters can be changed such as type of actuator, side of installation, valve opens/closes with increasing setpoint value, and characteristics curve of the valve (values set ex-factory: stroke actuator, mounting side: left, valve opens with increasing setpoint value, linear characteristics curve).

Thereafter an AUTOSTART can be performed; during which the SRD960 determines independently the geometric data of the actuator as well as control parameter, to ensure an optimized operation with the attached valve.

More see page 26.

### Bus Connection

The SRD 960 in the version PROFIBUS-PA is bus compatible, which means that to a 2-core lead the instruments have to be attached parallel according to IEC 1158-2.

The lead serves as voltage feeder as well as for digital communication. To activate each instrument individually, an individual address has to be entered.

Ex-factory always the address 126 is stored <sup>1)</sup>; since this address cannot be used during operation, a new address has to be entered in every instrument. This can be done via the local keys, with the PC20-software or a commercial configurator.

To a PROFIBUS-PA-segment with a length of up to 1900 m, up to 32 instruments can be attached. A maximum of up to 126 instruments can be addressed at the PROFIBUS.

### System Integration

During operation the SRD960 will communicate with a PROFIBUS master class 1. The required GSD-file ("instrument-specific dates") can be downloaded from the Internet by path

[http://www.foxboro-eckardt.com/products/srd960\\_en.html](http://www.foxboro-eckardt.com/products/srd960_en.html)

There a further document is made available, which explains the communication data and parameters in detail.

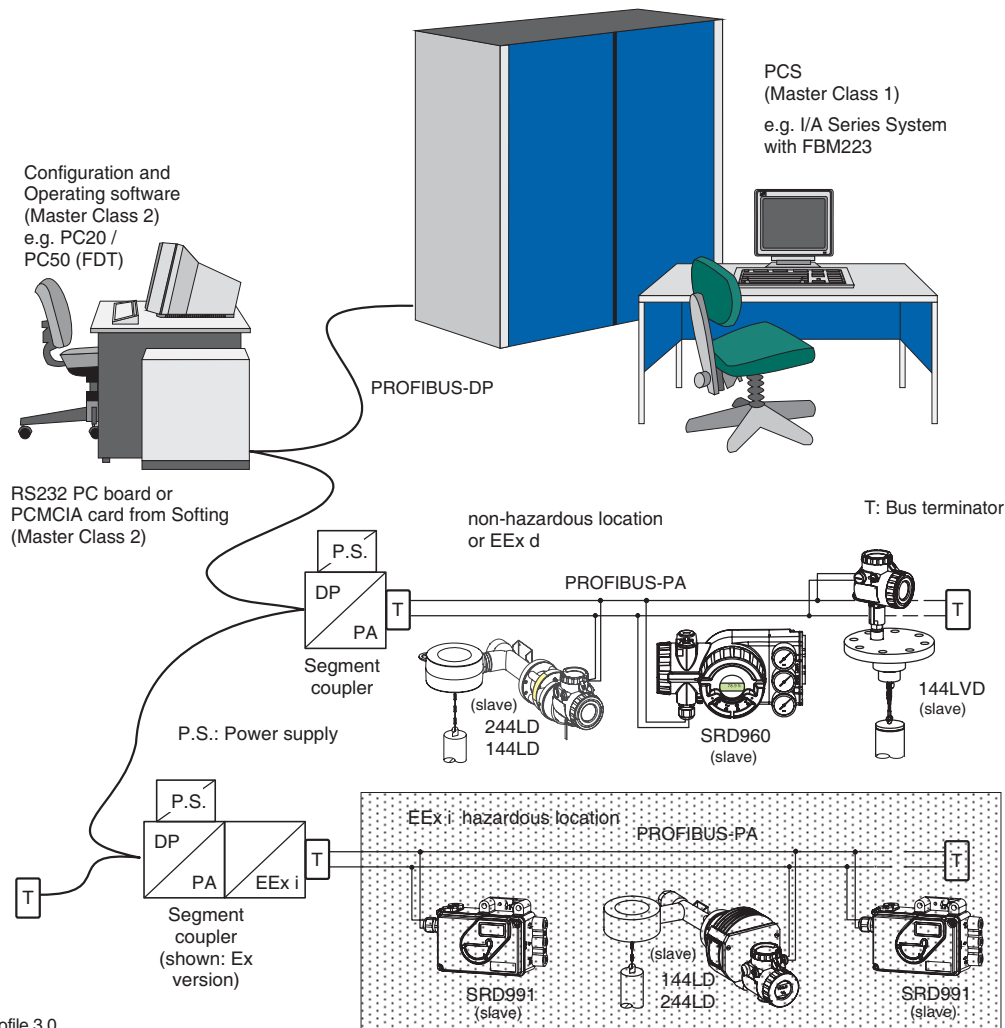

1) as per profile 3.0

More informations about PROFIBUS see [www.profibus.com](http://www.profibus.com)

## Summary – FoxCom (digital)

Start-up according to following logical steps:

### Mounting to Actuator (Valve)

The SRD960 can be mounted to stroke or rotary actuators. More see page 13.

### Connection and Start-up

Carry out the pneumatic tubing. More see page 22.

Upon connection of supply air and a voltage source of e.g. DC 24 V to the input terminals (pay attention to polarity, see page 23) an initial start-up can be carried out without any further equipment.

With the local push buttons, basic parameters can be changed such as type of actuator, side of installation, valve opens/closes with increasing setpoint value, and characteristics curve of the valve (values set ex-factory: stroke actuator, mounting side: left, valve opens with increasing setpoint value, linear characteristics curve).

Thereafter an AUTOSTART can be performed; during which the SRD960 determines independently the geometric data of the actuator as well as control parameter, to ensure an optimized operation with the attached valve.

More see page 26.

FoxCom version:

The positioner can be operated either locally via PC or via I/A Series System (FoxCom)

### System configuration

When using 'Communication' (a digital signal with constant amplitude), it must be ensured that the connected outputs, buffer amplifier and barriers are compatible with the frequency ranges used. In addition to the load, the AC impedances requirements must be met. Therefore, it is recommended that only the specified amplifier, barrier and configuration device is used.

More see page 58.

To prevent crosstalk between lines and reduce disturbances through electromagnetic influences, it is recommended that twisted-pair shielded lines be used, with a diameter of AWG 22 - 14 (0,3...2,5 mm<sup>2</sup>) and a max. capacity of 100 pF/m.

The line capacities and connected devices may not exceed the maximum values listed for a particular FoxCom protocol.

All components which are connected to the SRD in an explosion hazardous area, require an Ex-Approval. The therein applicable limit values must not be exceeded in any event. These limit values also have to be adhered to when connecting additional capacitances, inductances, voltages and currents.

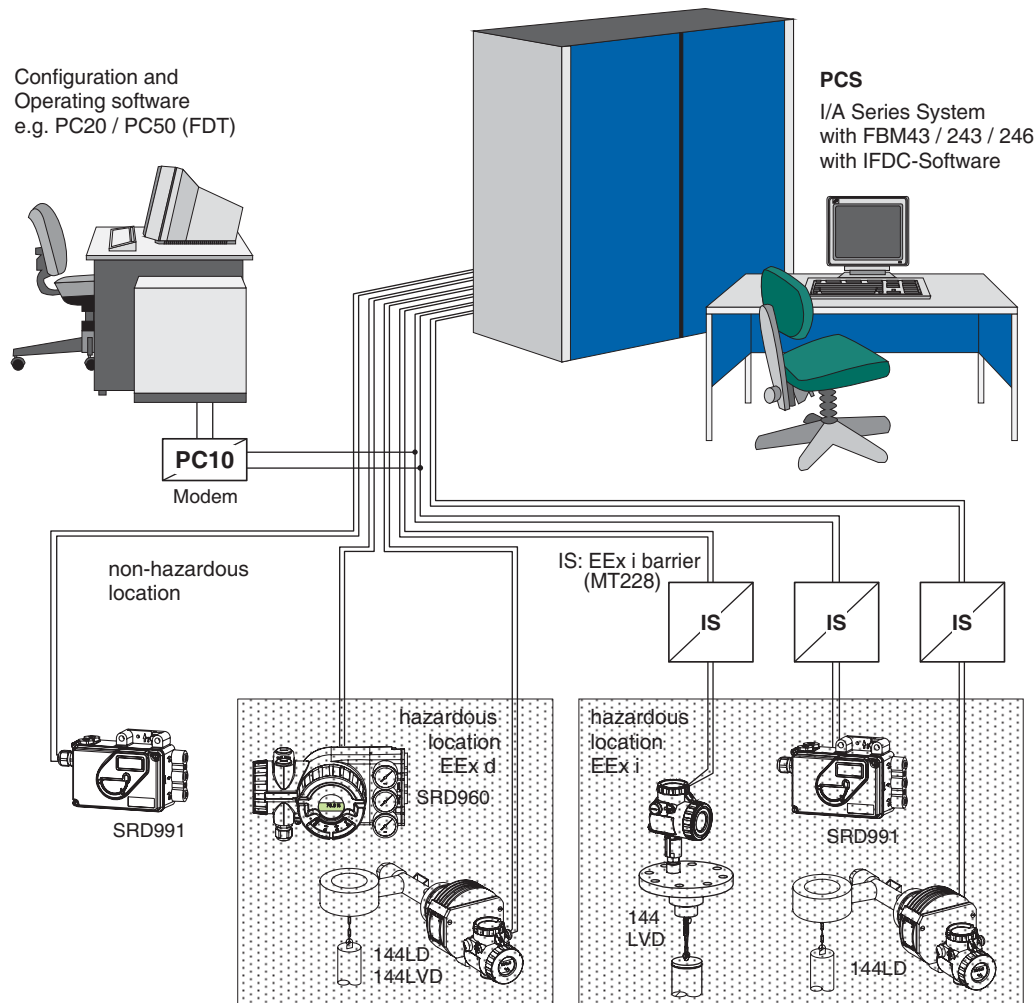

## 1 METHOD OF OPERATION

### 1.1 General

The intelligent positioner **1** and the pneumatic actuator **2** form a control loop with the setpoint value  $w$  (from master controller or control system), the output pressure  $y$  and the position  $x$  of the actuator on valve **3**.

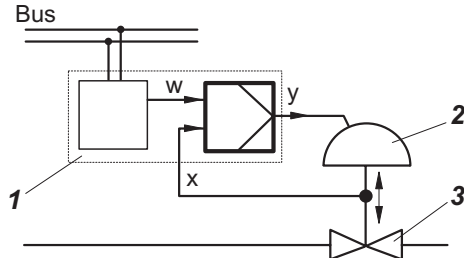

Fig.: Fieldbus version

For the supply air, we recommend the FOXBORO ECKARDT FRS923 filter regulator.

The positioner can be attached to both linear actuators and rotary actuators.

Actuators with spring force are controlled by a single acting positioner. Actuators without spring force are controlled by a double acting positioner.

HART or FoxCom version:

The positioner can be operated locally by means of local keys or Hand Held Terminal, remotely via PC-based configuration or a corresponding control system as, e.g. I/A Series System.

PROFIBUS-PA or FOUNDATION Fieldbus version:

The positioner can be operated locally by means of local keys, remotely via a corresponding control system or can be operated via PC-based configuration and operating tools as, e.g. PC20 / IFDC.

### 1.2 Block diagram

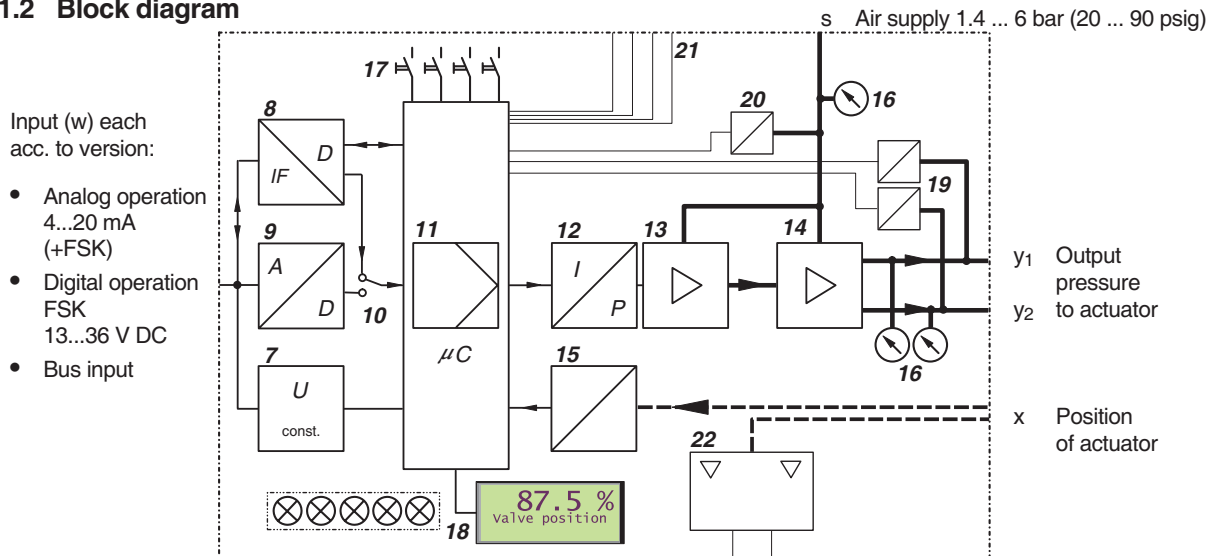

### 1.3 Operation

With the intelligent positioner with input signal 4-20 mA or superimposed HART signal, the supply takes place via the power signal adjacent to the input.

By means of voltage converter **7**, derivation of the internal supply of the electronic takes place. The power value is measured, in A/D transformer **9** converted, and directed via switch **10** to digital controller **11**.

With PROFIBUS-PA or FOUNDATION Fieldbus, the SRD is powered by means of the bus lead. The positioner is operated from a control system by sending a setpoint (setpoint value) to the positioner. The digital signal is directed via the interface component **8** to the digital controller **11**. By means of the voltage converter **7** the internal supply of the electronic is established, fed via the bus lead.

With FoxCom digital operation a DC voltage is provided at input  $w$ . On this voltage a FSK-signal is modulated. The modulation contains information (eg setpoint value), sent digitally to the control unit **11** across the FSK-unit **8**.

The output of controller **11** drives the electro-pneumatic converter (IP-module) **12**, controlling a pre-amplifier **13**, the single acting (or double acting) pneumatic power amplifier **14**. The output of the amplifier **14** is the output pressure  $y$  to the actuator.

The pneumatic amplifiers are supplied with supply air  $s$  1.4 to 6 bar (20 to 90 psig).

The position  $x$  of the actuator is sent to the control unit **11** by the position sensor (conductive plastic potentiometer) **15**.

Optional gauges **16**, pressure sensors **19**, **20**, inputs / outputs **21** (two binary outputs; a 4-20 mA output and alarm; control inputs for 'Open/Close' and 'Hold last value') enable additional diagnostic indications and possible intervention. The mechanical limit switch **22** (optional) enables independent alarm signals.

Adjusting, start-up of the positioner as well as the demand for internal information can be made using the local keys **17** with indication given by LCDs **18** or LEDs.



## 2 OPERATING MODES

Operation of the positioner is divided into individual 'operating modes'. Operating modes may change depending on, for example, key commands or internal calculations. The different operating modes are described in abbreviated form below.

### INITIALIZE:

Upon power-up or Reset (pressing of keys **(0)** **(-)** **(+)** simultaneously), several self-tests are conducted. Individual steps in the self-test process are indicated by the LCD or green LEDs.

If no error occurs the device moves to OUT OF SERVICE, if it is still in a delivery condition; AUTOSTART has to be performed. If AUTOSTART was done already, the device will go to IN OPERATION.

If faults are detected, the code of the faulty self-test will remain (see page 53). If error reoccurs after reset, the device is probably defect and should be sent in for repair.

### DEVICE FAULT:

In the event that the LCD shows a message (or red LED lights up constantly and all green LEDs are off), a device fault is signaled. These faults are detected during cyclical self-test.

The device can no longer be operated. This could be caused a. o. by a jammed menu key, defect program memory, etc. (see chapter "Trouble-shooting").

This condition disappears through new resetting until the same error is detected again. If a device error occurs repeatedly, the device should be sent in for repair.

### IN OPERATION:

After performing an AUTOSTART, the device moves to IN OPERATION and will always, even after restarting or re-setting, move back to the safety position (de-energized valve position) or FAILSAFE. If setpoint values are fed via communication, the SRD will go to IN OPERATION.

### FAILSAFE:

Positioner carries out actions as configured in menu "failure handling". Additionally, the cyclical self-diagnosis takes place.

If the instrument is IN OPERATION, but no setpoint values arrive via communication, the SRD will go to FAILSAFE mode, after a defined time period; either with

- maintaining last value
- output pressureless, or
- with predetermined position.

As soon as setpoint values arrive via communication again, the instrument is immediately back IN OPERATION.

### OUT OF SERVICE:

The SRD960 in its delivery condition is configured in such a way that it will remain OUT OF SERVICE after power-up until moving to IN OPERATION via the manually initiated function AUTOSTART.

In the device state OUT OF SERVICE the menu entering mode remains active at all times. If a device has been IN OPERATION already and is removed from an actuator and mounted to another, it is recommended to take the device out of operation via RESET CONFIG (Menu 9.1) prior to disconnecting the device from the first actuator.

This enables the next actuator to be started in the delivery condition (see chapter 8).

### CALIBRATE:

During an AUTOSTART function the device is in condition CALIBRATION. The actuator is moved up- and downwards several times, and the device could be busy for a longer period of time. Subsequently, the device moves to IN OPERATION.

### MESSAGE:

The SRD960 continuously supervises its important device functions. In the event that limit values are exceeded or operational problems occur, messages are signaled via the LCD or the special LED blinking mode: red LED with long, green LEDs with short fluorescent time.

The message with the highest priority will be indicated first. With key **(-)** additional messages can be called up, with key **(+)** the measuring values can be retrieved. It is possible at all times to reach the menu by pressing the menu keys to possibly eliminate the problem by performing suitable menu functions. Further references may be found in chapter "Trouble-shooting".

### SIMULATE (FOUNDATION FIELDBUS version only)

During function IN OPERATION, the valve position queried via the communication, can be simulated with a value that has been entered via communication into the instrument during position SIMULATION. Thereby the positioner continues with normal operation and regulates to the "accurate" set value.

For the SRD, this function has to be additionally released or blocked via menu 10.

LCD description, definition of the LEDs and possible operator interventions are described in chapter: START-UP.

### 3 FUNCTIONAL DESIGNATIONS

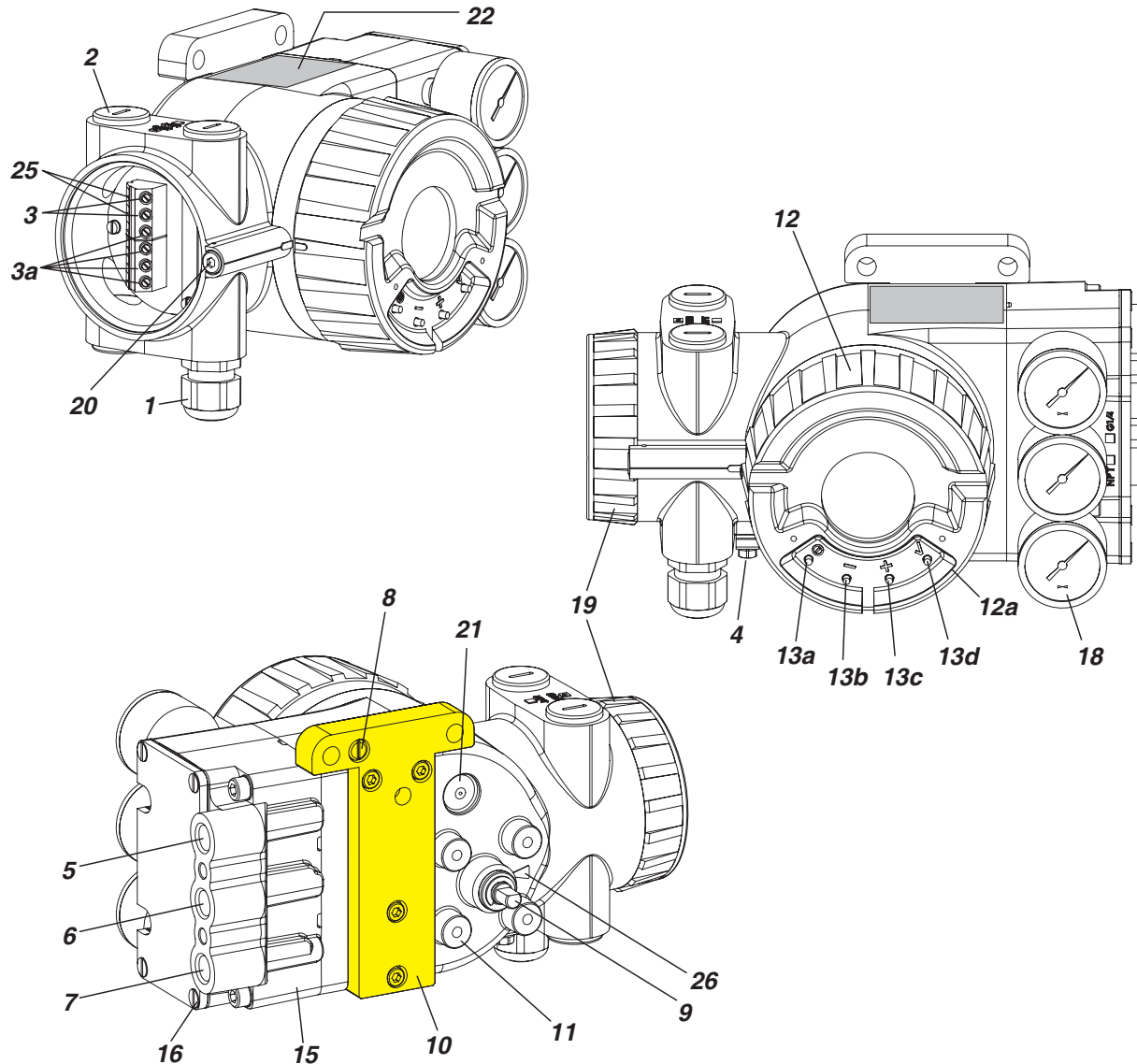

- |   |   |
|---|---|
| <p><b>1</b> Cable gland <sup>1)</sup></p> <p><b>2</b> Plug <sup>1)</sup>, interchangeable by Pos <b>3</b></p> <p><b>3</b> Screw terminals <sup>2)</sup> (11 +/12 -) for input (w) or (11 / 12) for Bus connection acc. IEC 1158-2</p> <p><b>3a</b> Screw terminals <sup>2)</sup> for additional inputs / outputs</p> <p><b>4</b> Ground connection</p> <p><b>5</b> Female thread G ¼ or ¼-18 NPT <sup>3)</sup> for output I (y1)</p> <p><b>6</b> Female thread G ¼ or ¼-18 NPT <sup>3)</sup> for air supply (s)</p> <p><b>7</b> Female thread G ¼ or ¼-18 NPT <sup>3)</sup> for output II (y2)</p> <p><b>8</b> Direct connection for output I (y1-d)</p> <p><b>9</b> Feedback shaft</p> <p><b>10</b> Connection manifold for attachment to stroke actuators (see page 12)</p> <p><b>11</b> Connection base for attachment to rotary actuators</p> <p><b>12</b> Cover with window and external push buttons</p> <p><b>12a</b> Push button protection cover (option -X) (not shown)</p> | <p><b>13a</b> Key <b>ⓘ</b> MENU</p> <p><b>13b</b> Key <b>-</b> DOWN</p> <p><b>13c</b> Key <b>+</b> UP</p> <p><b>13d</b> Key <b>✓</b> ENTER / STORE</p> <p><b>15</b> pneumatic unit with amplifier and connection</p> <p><b>16</b> 4 screws for connection of pneumatic unit</p> <p><b>18</b> built-in pressure gauges for air-supply, output Y1 and output Y2</p> <p><b>19</b> Cover for electronic connection compartment</p> <p><b>20</b> Protection screw for electronic connection and electronic compartment</p> <p><b>21</b> Air vent, dust and water protected, (IP65 and NEMA 4X)</p> <p><b>22</b> Data label</p> <p><b>22a</b> Label for Options</p> <p><b>25</b> Tip jacks, 2 mm dia. (integrated in Terminals)</p> <p><b>26</b> Arrow is perpendicular to shaft <b>9</b> at angle 0 degree</p> |
|---|---|

1) Cable glands BUSG.  
The device is supplied with dust protection covers

2) optional: Cage clamps (WAGO)

3) Type of thread is marked at housing.

**3.1 Pneumatic Accessories**

When mounting, check the proper seating of the O-rings and bolt on the accessories with the two M8 bolts. Unused outputs are closed by means of plastic plugs.

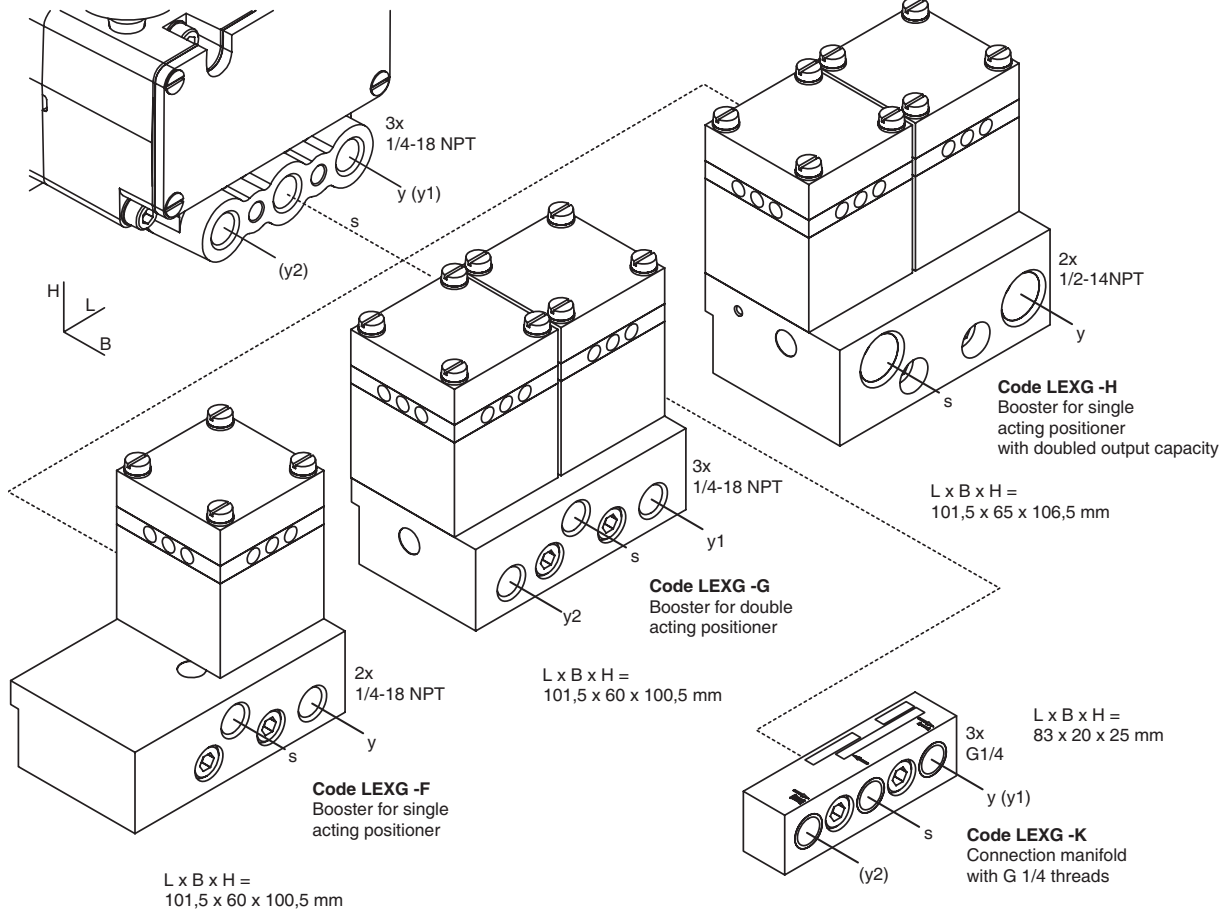

Unused threads for pressure gauge are closed by means of lock screw Part No. 425 024 013.

Types with G-threads instead of standard NPT-threads:

- LEXG-F1: As LEXG-F, however with thread G 1/4
- LEXG-G1: As LEXG-G, however with thread G 1/4
- LEXG-H1: As LEXG-H, however with thread G 1/2

Alternative:

Amplifier, independent of positioner:

(Connection from positioner to amplifier with tubes)

LEXG-X1: As LEXG-F1, however externally mounted

LEXG-Y1: As LEXG-G1, however externally mounted

LEXG-Z1: As LEXG-H1, however externally mounted

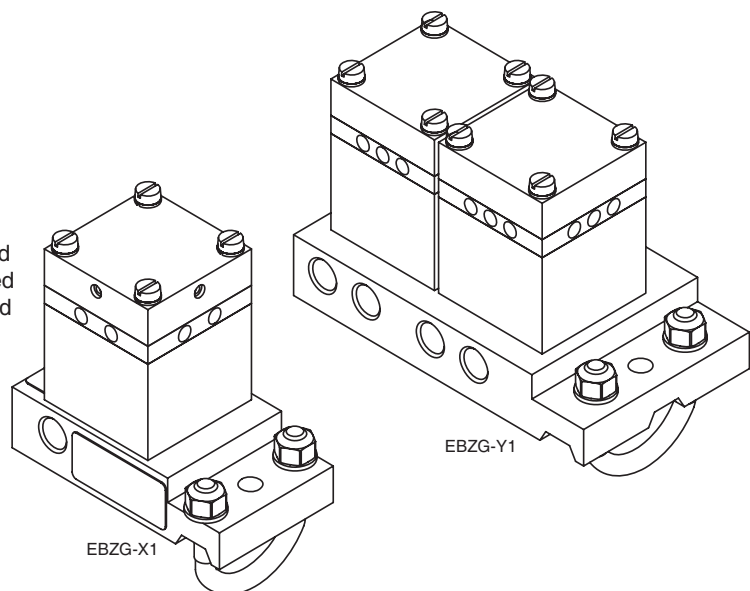

## MOUNTING PREPARATION

The Universal Positioner needs a linking piece for attachment to the different brands of actuators.

The standard Mounting Adapter is marked with Option N.

### Mounting adapters

Be sure to have the right mounting adapter.

#### Option N for:

- NAMUR mounting, according to IEC 534-6
- Direct mounting to FlowPak- and FlowTop actuators
- Rotary actuators, according to VDI/VDE 3845

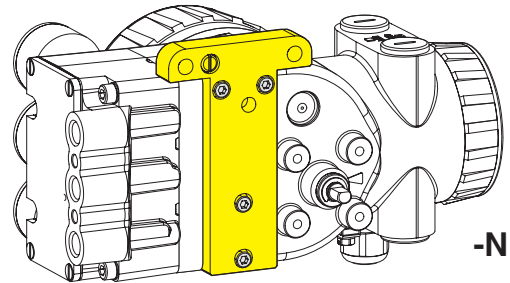

#### Option R for:

- Rotary actuators, according to VDI/VDE 3845

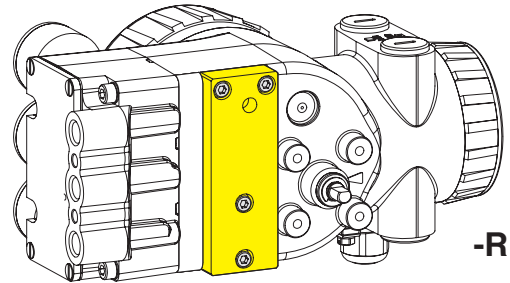

#### Option T for:

- Integrated mounting with air connections on rear
- Direct mounting to e.g. Kämmer valves / actuators
- Rotary actuators, according to VDI/VDE 3845

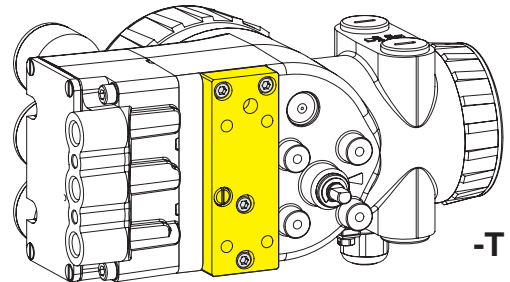

#### Option D for:

- NAMUR mounting, according to VDI/VDE 3847 (see PSS)
- Rotary actuators, according to VDI/VDE 3845

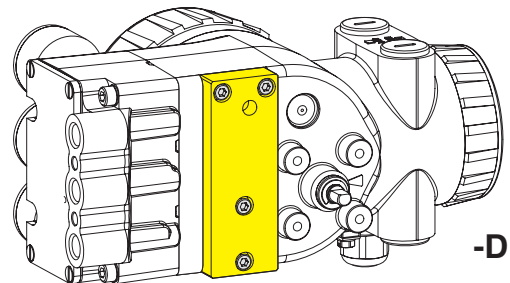

#### Option F for:

- NAMUR mounting, according to IEC 534-6
- Rotary actuators, according to VDI/VDE 3845

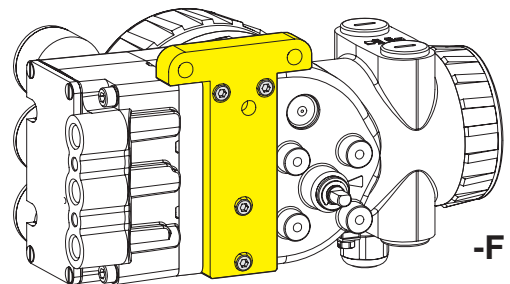

On the following pages different ways of mounting are shown:

NAMUR mounting - left hand -

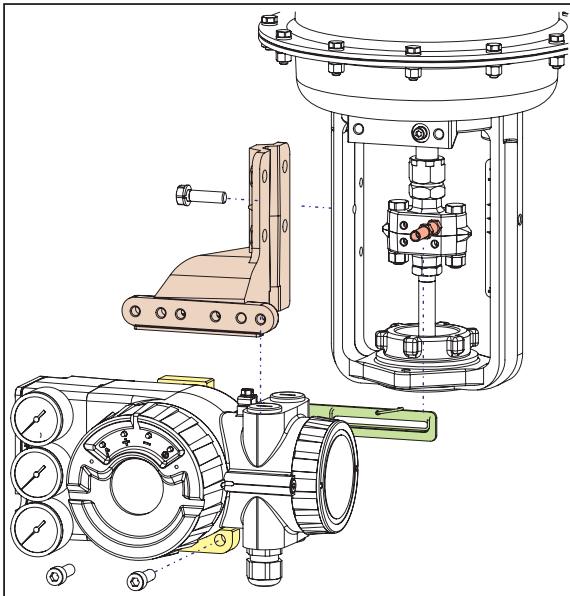

NAMUR mounting - right hand -

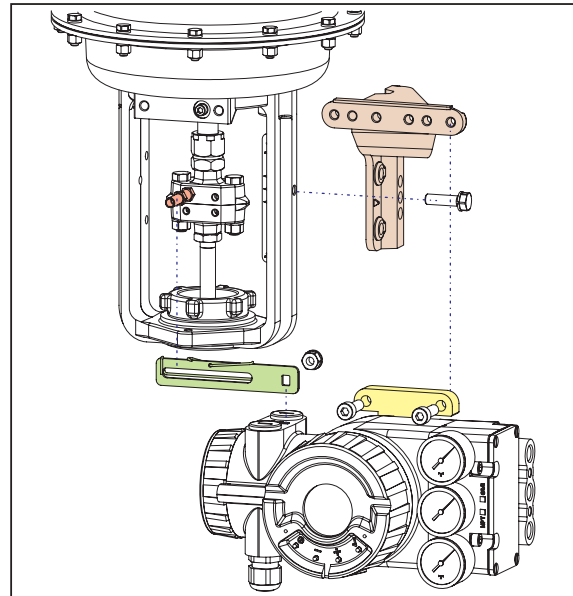

Direct mounting

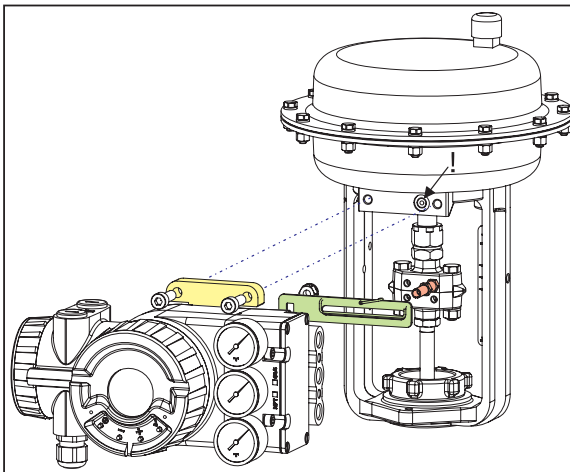

Mounting to rotary actuators

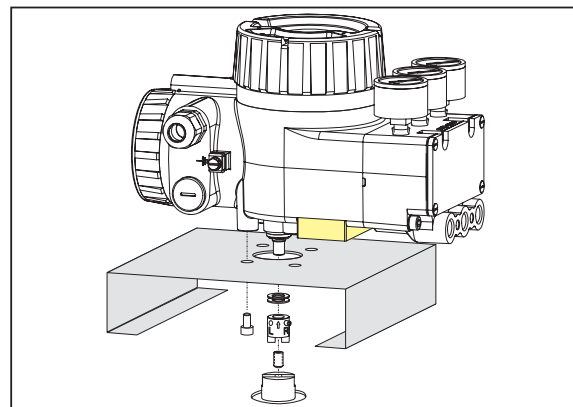

**Feedback lever for linear actuators :**

The carrier bolt **B** is in the slot of the feedback lever **A** and the compensating spring **F** touches the carrier bolt.

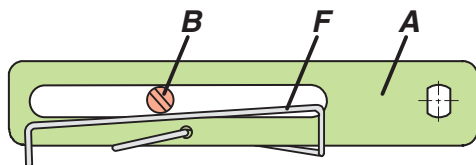

**Carrier bolt B:**

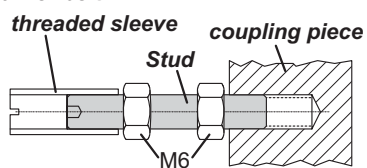

## 4 MOUNTING TO LINEAR ACTUATORS

### 4.1 NAMUR Mounting - left hand -

Applicable to actuators with cast yoke or pillar yoke acc. to NAMUR (DIN IEC 534-6).

Mounting the positioner with pneumatic connections on the left side and electrical connections on the lower side.

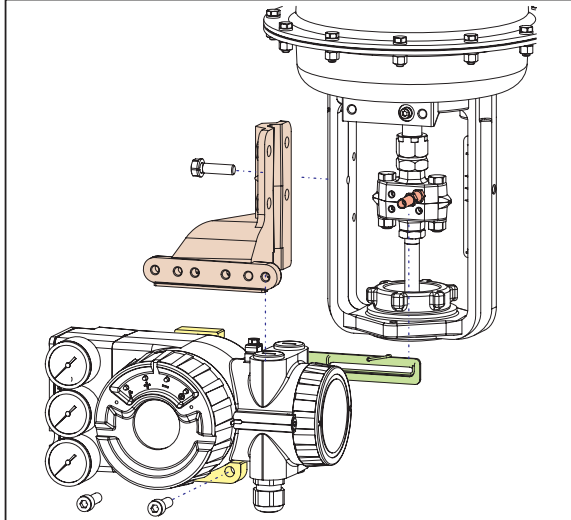

Attachment of the positioner to the actuator is made to the left using the mounting bracket and feedback lever for a NAMUR mount. Use:

attachment kit EBZG -H for a cast yoke, or attachment kit EBZG -K for a pillar yoke.

The side outputs I (or I and II, see page 10) are used. The rear output I is closed by means of a lock screw 522 588 013.

Pneumatic connections: Do not use Teflon tape for sealant. The fine fibres could disturb the function of the SRD. Use only Loctite® #243 for sealant <sup>1)</sup>.

Screw-type glands for electrical connections are positioned on the lower or right side. Any unused threaded holes are closed by plugs.

#### 4.1.1 Preparation of the positioner

Rotate the shaft **9** so that the flat on the shaft stub is perpendicular to the arrow **26** on the housing (detail see page 19). Fasten the feedback lever **A** to the shaft by means of spring washer and nut M8.

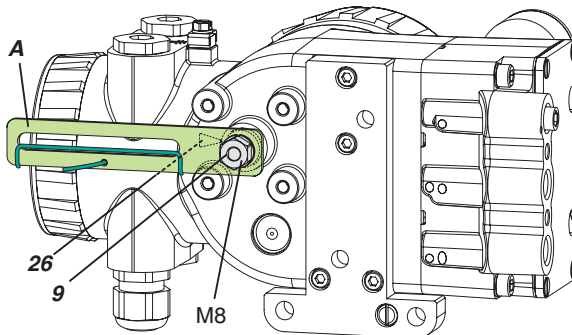

1) Apply only to male thread.

#### 4.1.2 Preparation of the actuator

Screw the carrier bolt to the stem connector (see Fig.) and lock it by means of a counter nut.

A carrier bolt with an adjustable length is used to be able to screw on various coupling pieces.

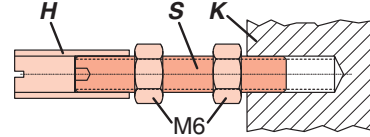

It consists of a stud **S**, which is screwed into the coupling piece **K** (with 3 mm Allen key) and locked with a lock nut M6. The threaded sleeve **H** is screwed onto it and locked with a lock nut M6. Make sure that the bolt is adjusted to the right length!

Fasten the mounting bracket to the left side of the yoke. For a cast yoke use a screw M8 x 30, for a pillar yoke use two U-bolts and two nuts.

#### 4.1.3 Mounting of the positioner

Fasten the positioner to the mounting bracket using two spring washers and two screws M8 x 80.

Note, the carrier bolt **B** is in the slot of the feedback lever **A** and the compensating spring **F** touches the carrier bolt.

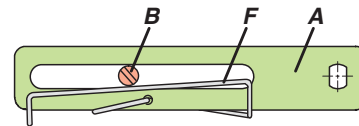

Fig.: Feedback lever

For optimum utilization of the positioner operating range, it is recommended that the arrangement is adjusted according to the following procedure before fixing. At an actuator position in the middle of travel range, the feedback lever position should be perpendicular to the actuator stem and the angle range should be between  $-10^\circ \dots +10^\circ$  and  $-30^\circ \dots +30^\circ$ .

Procedure:

Set the actuator to the middle of its travel range by supplying it with an independent pressure. Fasten the mounting bracket so that carrier bolt and the mark on mounting bracket are about the same distance from the valve body. Fasten the positioner to the mounting bracket so that a suitable angle range is selected.

It is recommended that the pneumatic and electrical connections are made after adjusting the position.

**4.1.4 NAMUR Mounting Dimensions – left hand –**

LCD orientation can be changed by means of local push buttons under Menu 9.9.2 to „flipped“, to ensure a correct orientation of the display.

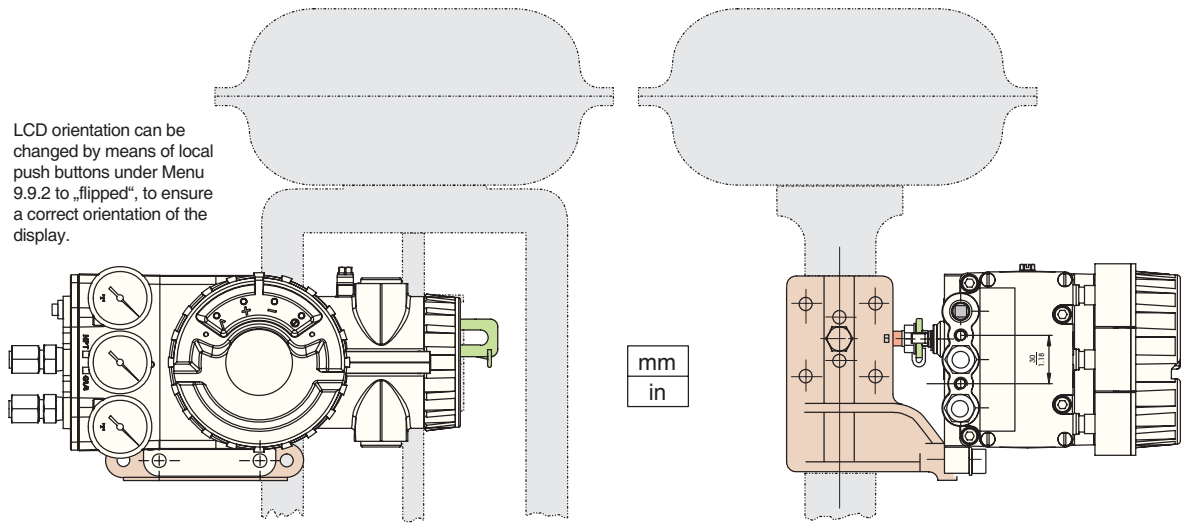

**Attachant to casting yoke**  
(with attachment kit  
Code EBZG -H)

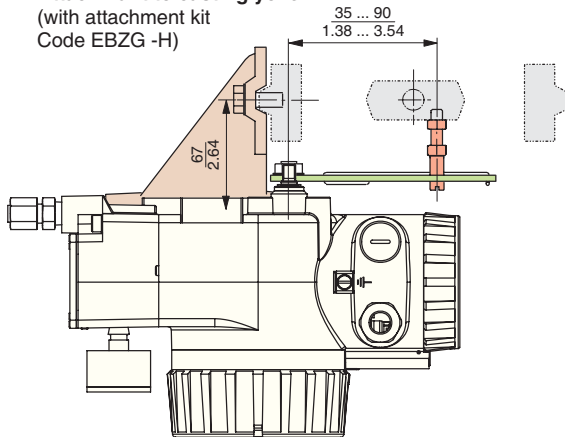

**Mounting bracket**

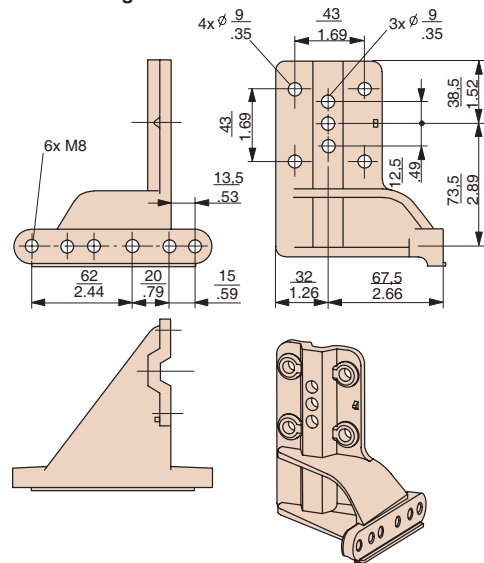

**Attachment to pillar yoke**  
(with attachment kit  
Code EBZG -K)

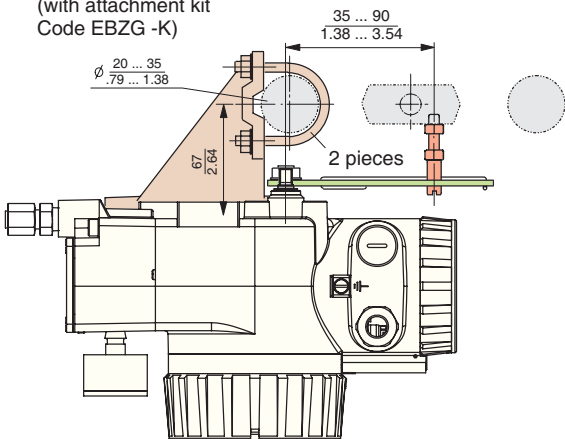

**Feedback lever** Code EBZG-A for 8..70 mm travel

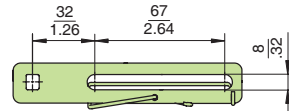

**Feedback lever** Code EBZG-B for 60..120 mm travel

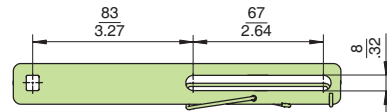

**Carrier bolt** for connection to valve stem

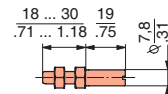

## 4.2 NAMUR Mounting, right hand

Right-hand mounting is done if for instance left-hand mounting is not possible for structural reasons.

Applicable to actuators with cast yoke or pillar yoke acc. to NAMUR (DIN IEC 534-6).

Mounting the positioner with pneumatic connections on the right side and electrical connections on the lower side.

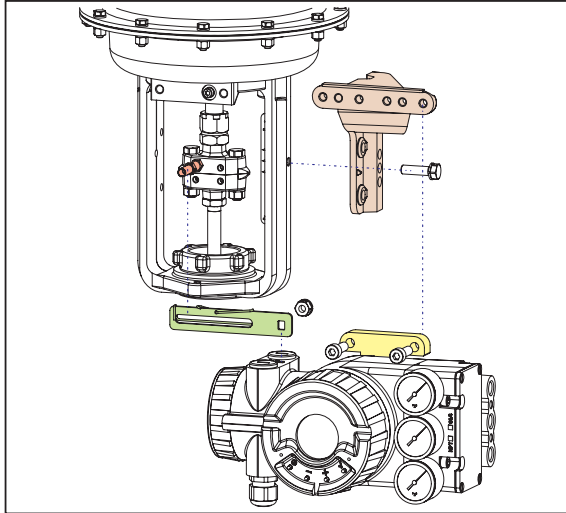

Attachment of the positioner to the actuator is made to the right using the mounting bracket and feedback lever for a NAMUR mount. Use:

attachment kit EBZG -H for a cast yoke, or  
attachment kit EBZG -K for a pillar yoke.

The side outputs I (or I and II, see page 10) are used.  
The rear output I is closed by means of a lock screw 522 588 013.

Pneumatic connections: Do not use Teflon tape for sealant. The fine fibres could disturb the function of the SRD. Use only Loctite® #243 for sealant <sup>1)</sup>.

Screw-type glands for electrical connections are positioned on the lower side. Any unused threaded holes are closed by plugs.

### 4.2.1 Preparation of the positioner

Rotate the shaft stub of shaft **9** so that the flat on the shaft stub is perpendicular to the arrow **26** on the housing (detail see page 19). Fasten the feedback lever **A** to the shaft by means of spring washer and nut M8.

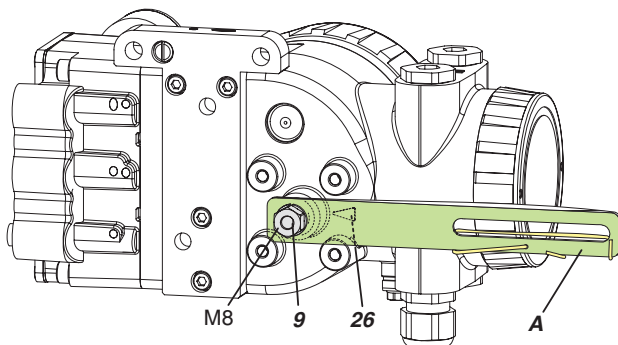

### 4.2.2 Preparation of the actuator

Screw the carrier bolt to the stem connector (see Fig.) and lock it by means of a counter nut.

A carrier bolt with an adjustable length is used to be able to screw on various coupling pieces.

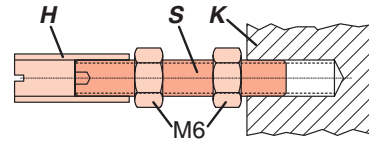

It consists of a stud **S**, which is screwed into the coupling piece **K** (with 3 mm Allen key) and locked with a lock nut M6. The threaded sleeve **H** is screwed onto it and locked with a lock nut M6. Make shure that the bolt is adjusted to the right length!

Fasten the mounting bracket to the right side of the yoke. For a cast yoke use a screw M8 x 30, for a pillar yoke use two U-bolts and two nuts.

### 4.2.3 Mounting of the positioner

Fasten the positioner to the mounting bracket using two spring washers and two screws M8 x 80.

Note, the carrier bolt **B** is in the slot of the feedback lever **A** and the compensating spring **F** touches the carrier bolt.

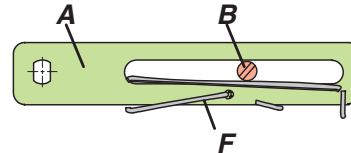

Fig.: Feedback lever

For optimum utilization of the positioner operating range, it is recommended the arrangement be adjusted according to the following procedure before fixing. At an actuator position in the middle of travel range, the feedback lever position should be perpendicular to the actuator stem and the angle range should be between  $-10^\circ \dots +10^\circ$  and  $-30^\circ \dots +30^\circ$ .

Procedure:

Set the actuator to the middle of ist travel range by supplying it with an independent pressure. Fasten the mounting bracket so that carrier bolt and the mark on mounting bracket are about the same distance from the valve body. Fasten the positioner to the mounting bracket so that a suitable angle range is selected.

It is recommended that the pneumatic and electrical connections are made after adjusting the position.

1) Apply only to male thread



4.2.4 NAMUR Mounting Dimensions – right hand –

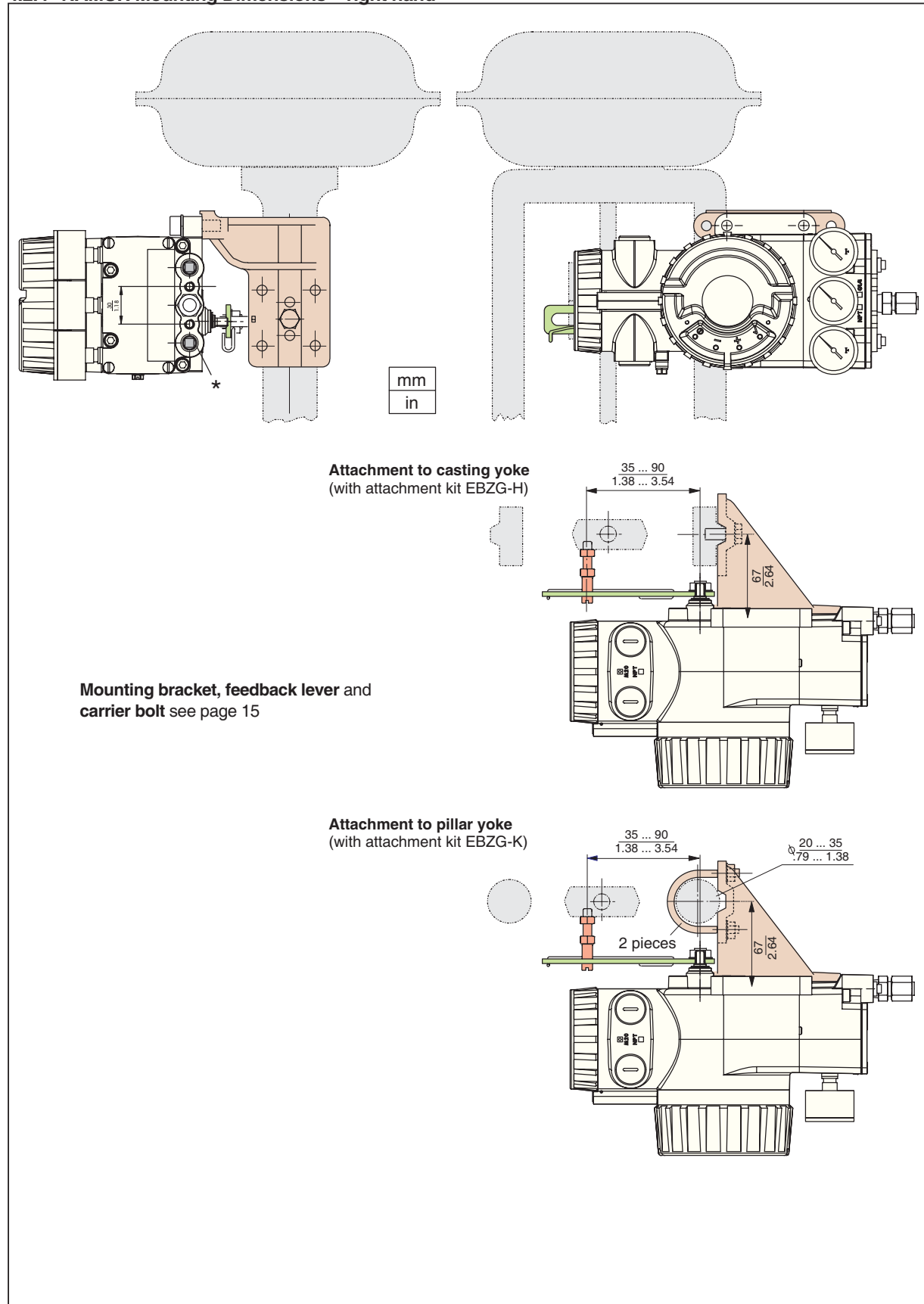

### 4.3 Linear actuator, direct mounting

Actuators with appropriately prepared yoke (PA200, PA350) enable mounting of the SRD directly to the actuator yoke.

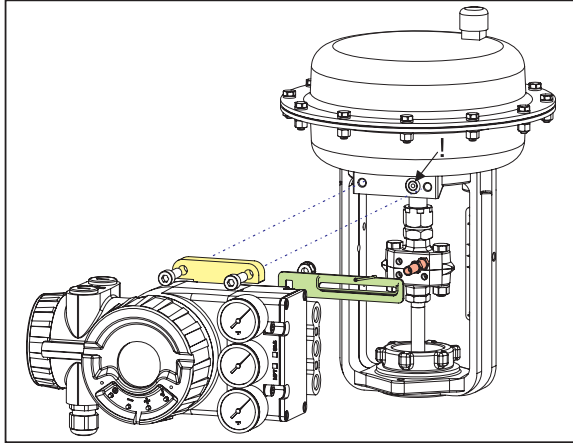

The attachment of the positioner is accomplished by bolting it directly to the actuator yoke using the feedback lever for a direct mount (with attachment kit EBZG -E).

The rear output I and the side outputs I and II are used as follows (see page 10) :

- Actuator single acting, spring force closes:  
The rear output I is used (remove lock screw in hole **D**).  
The side output I is closed by means of a lock screw (see page 18).
- Actuator single acting, spring force opens:  
The side output I is used.  
The rear output I is closed by means of a lock screw.
- Actuator double acting:  
The rear output I and the side output II is used.  
The side output I is closed by means of a lock screw (see page 18).

Pneumatic connections: Do not use Teflon tape for sealant. The fine fibres could disturb the function of the SRD. Use only Loctite® #243 for sealant<sup>1)</sup>.

Screw-type glands for electrical connections are positioned on the lower side. Any idle female threads are closed by means of plugs.

#### 4.3.1 Preparation of the positioner

Rotate the shaft stub of shaft **9** so that the flat on the shaft stub is perpendicular to the arrow **26** on the housing (detail see page 19). Fasten the feedback lever **A** to the shaft by means of spring washer and nut M8.

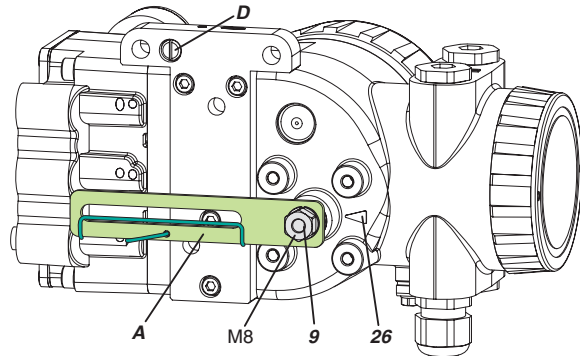

#### 4.3.2 Preparation of the actuator

Screw in the carrier bolt **B** on the coupling piece **K** on the drive spindle **S** at the lower left and lock it by means of a nut M6.

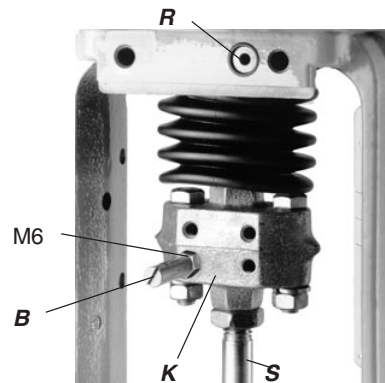

#### 4.3.3 Mounting of the positioner

Fasten the positioner to the upper part of the yoke using 2 spring washers and 2 screws M8 x 80, as shown above. The rear output I of positioner has contact to the air duct **R** in the yoke.

**Attention:** Note the correct position of the O-ring on the yoke for the rear connection !!

Note, the carrier bolt **B** is in the slot of the feedback lever **A** and the compensating spring **F** touches the carrier bolt.

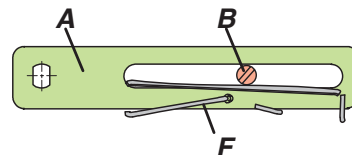
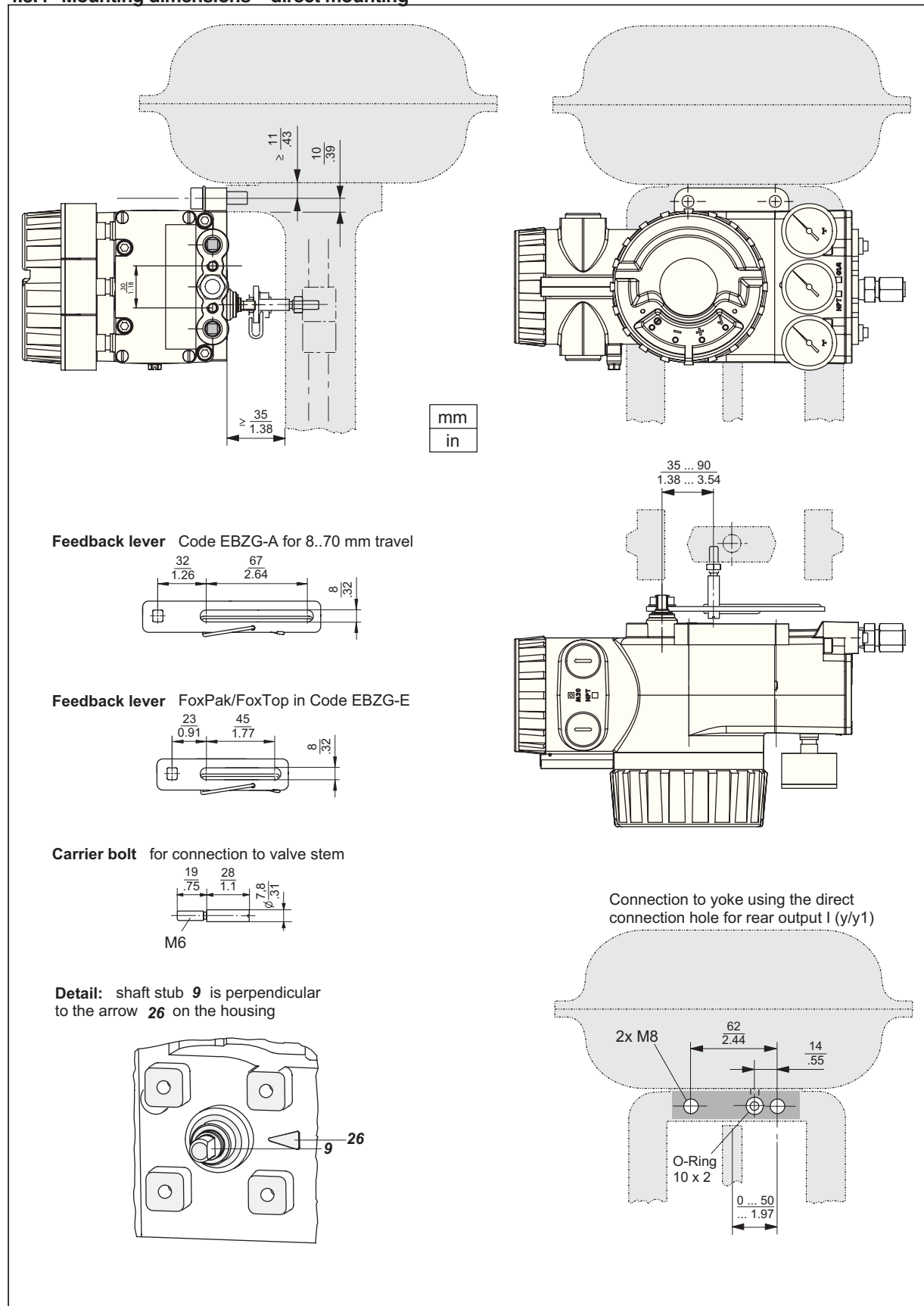

Fig.: Feedback lever

1) Apply only to male thread.

4.3.4 Mounting dimensions – direct mounting –



### 4.4 Mounting to rotary actuators

Applicable to rotary actuators that meet the VDI/VE 3845 standard for mounting. Installation position of positioner: Mount the positioner so that the pneumatic connections are in the same direction as the longitudinal drive axis of the actuator as shown in the Fig. below.

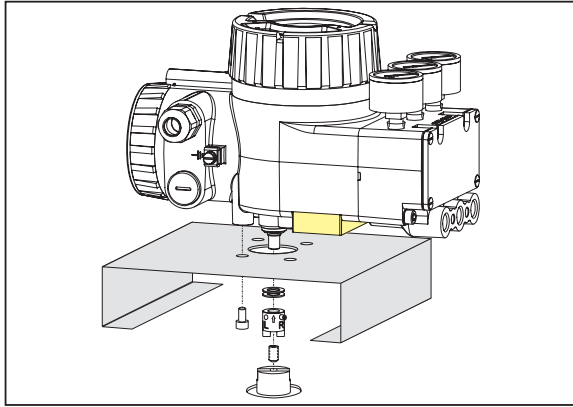

**Attention:** The feedback shaft **9** of the SRD has no mechanical stop, therefore may spin round. The permissible rotation angle range is between +50 and -50 degrees around the arrow at the housing concerning the flat area of the feedback shaft (also see detail page 19 bottom). Since a rotary actuator has a rotary angle of about 90 degrees the mounting as described in the following must be carried out very precise.

Attachment of the positioner to the actuator is made by using the rotary adaptor kit EBZG -R.

Either the side outputs I (or I and II) are used and the rear output I is closed by means of the lock screw 522 588 013.

Pneumatic connections: Do not use Teflon tape for sealant. The fine fibres could disturb the function of the SRD. Use only Loctite® #243 for sealant <sup>1)</sup>.

Screw-type glands for electrical connections are used as needed. Any unused threaded holes are closed by plugs.

**Caution!** Prevent accumulation of water in the instrument in this mounting position by sealing cable entry against water. Provide a continuous supply of dry instrument air.

#### 4.4.1 Preparation of positioner

Valve must be in failsafe position and the direction of rotation of the actuator drive shaft must be known. These items are extremely important for proper functioning. These items can be checked as follows in case they are not clear:

In the single-acting actuator the force of the installed springs closes. The pressure-less actuator is in failsafe position. Through manually feeding compressed air it can be seen whether the actuator drive shaft rotates to the left or to the right. In the powerless SRD is y1 pressureless.

In the double-acting actuator without spring reset both air chambers are basically equal. Failsafe position can be either "open" or "close". Therefore, indication of the failsafe position has to be determined by engineering. Then the direction of rotation may be determined by manual feeding of compressed air. In the powerless SRD is y1 pressureless and y2 under pressure.

Bolt **2** is screwed into actuator drive shaft **1** for subsequent centering of the rotary adaptor **3**. The attachment console is mounted to the stroke actuator (see Fig.).

#### Attachment diagram for bracket

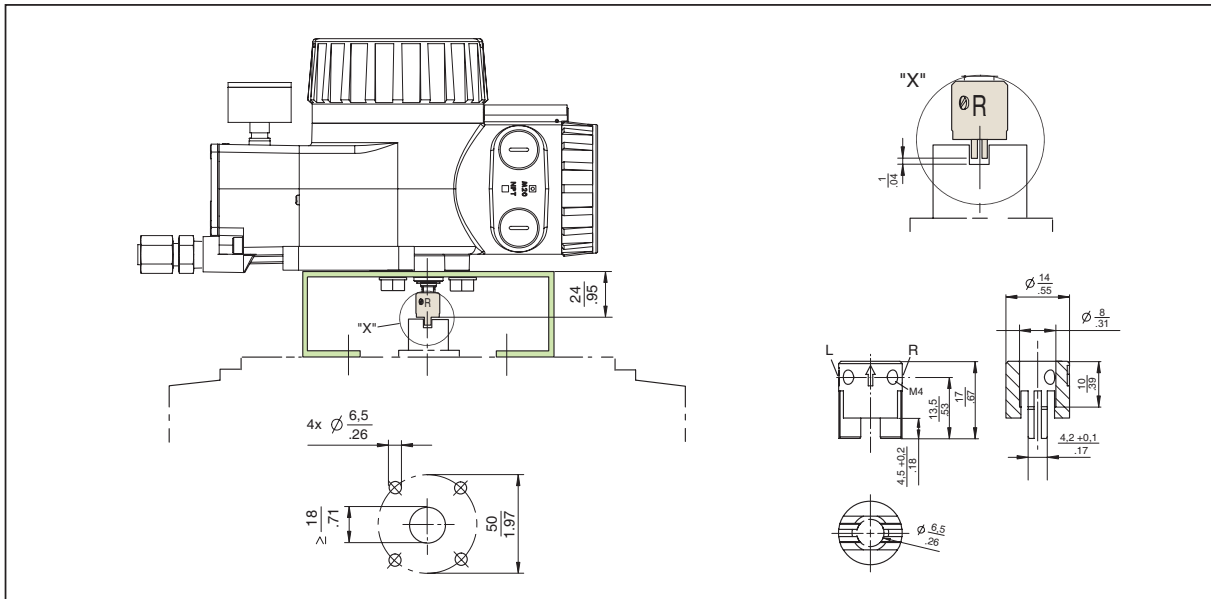

1) Apply only to male thread.

#### 4.4.2 Preparation of the actuator

First the rotary adaptor is being prepared:

For attachment to a counter-clockwise or **left** turning actuator secure the stud screw **4** in the threaded hole "L" of the rotary adaptor; hole "R" remains open. See Fig. 27.

For attachment to a clockwise or **right** turning actuator secure the stud screw **4** in the threaded hole "R" of the rotary adaptor; hole "L" remains open. See Fig. 28.

Now place the rotary adaptor **3** with two washers **5** on the feedback shaft **9** of the positioner against the stop.

Note :

When the product temperature rises, the drive shaft **1** becomes longer. Therefore, the rotary adaptor **3** must be mounted so that approx. 1 mm (0.04 in.) of clearance results between the drive shaft **1** and the rotary adaptor **3**. This is achieved by placing an appropriate number of washers **5** on the feedback shaft stub **9** before attaching the rotary adaptor. Two washers should result in a clearance of 1 mm.

Now screw and tighten the bolt in the coupling against the flat part of the feedback shaft (do not screw against thread!).

Finally turn the feedback shaft in such a way that the arrow of the coupling points to the arrow of the SRD housing. Beginning and end positions of the actuator drive shaft **1** and feedback shaft **9** are marked in figure 27 (counter clockwise rotating actuator) and in figure 28 (clockwise rotating actuator) by arrows for the respective direction of rotation.

The feedback shaft is now in the normal position corresponding to the failsafe position of the actuator.

#### 4.4.3 Mounting of positioner

SRD and actuator are in failsafe position.

Turn set screw **2** into shaft **1**.

Attach the SRD on the console in such a way that the catch of coupling **3** is guided into the groove of shaft **1**. Be careful not to shift shafts **1** and **9** and that both shafts are exactly flush. The set screw **2** can assist in alignment.

Fasten the positioner to the bracket by means of 4 lock washers and 4 screws M6 x 12.

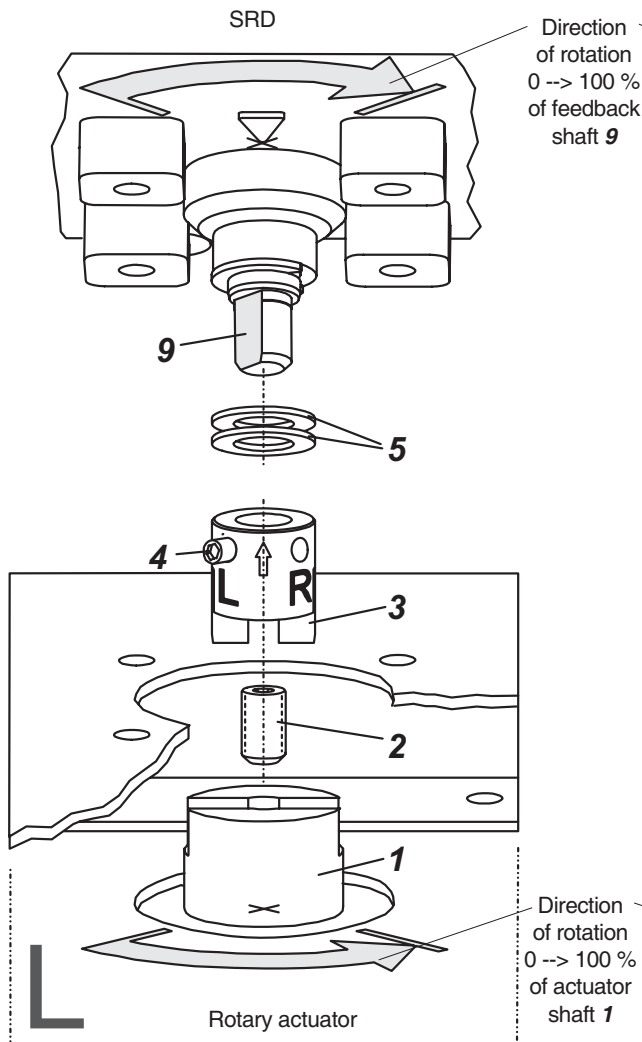

Figure 27: Mounting if actuator is left-rotating

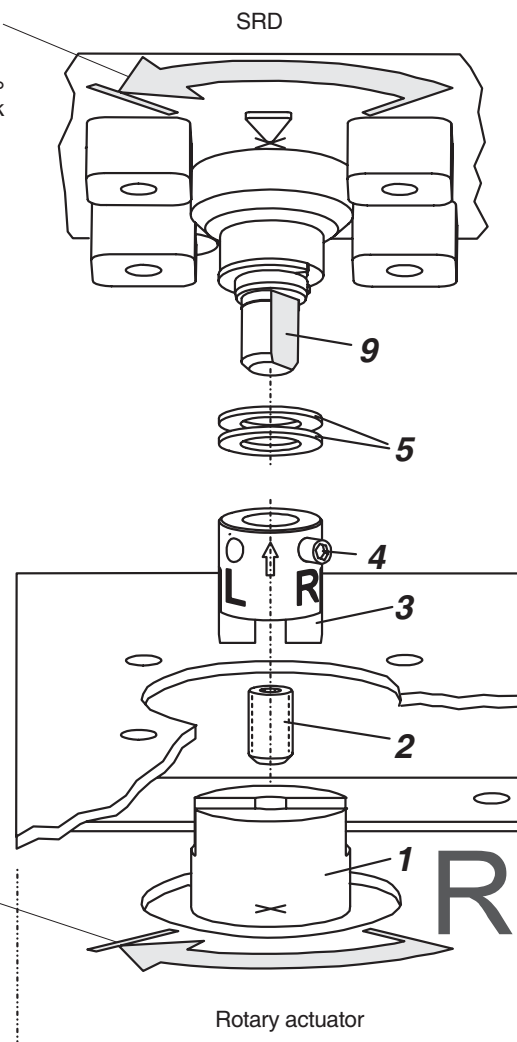
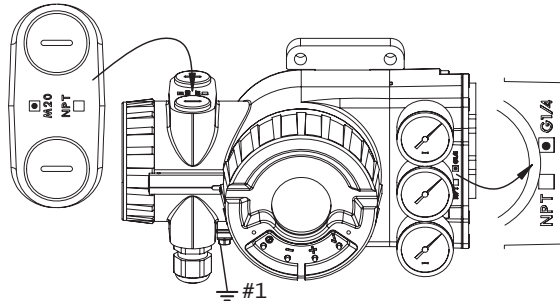

Figure 28: Mounting if actuator is right-rotating

## 5 PNEUMATIC CONNECTIONS

Following alignment and mounting of the positioner to the valve, pneumatic tubing has to be provided.

Check before mounting fittings and cable glands if threads are matching, otherwise housing can be damaged. Type of thread is marked at housing.



The connection illustrations depend on the respective version.

**s** Supply air

**y1-d** Output 1 for direct mounting, depressurized at currentless electronics. When using this output **y1** has to be closed by means of hex. screw.

**y1** Output 1, depressurized at currentless electronics. When using this output, **y1-d** has to be closed by means of sealing screw and O-ring.

**y2** Output 2 for double-acting actuator. Full pressure at currentless electronics. Closed at single-acting actuator.

**n1** Hex. Screw with NPT thread  
Part No. 522 588 013 (stainless steel)  
Part No. 556 446 016 (plastic)

**n2** Sealing screw with O-ring

### Direct Mounting (Single Acting)

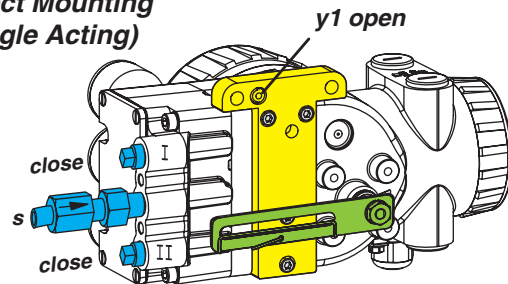

### Single Acting

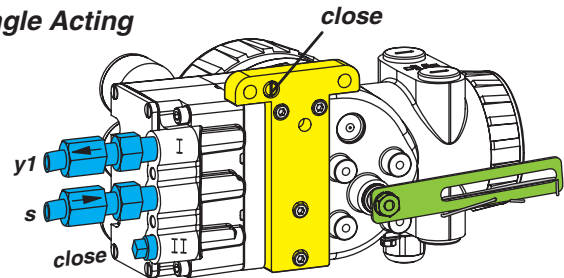

### Double Acting

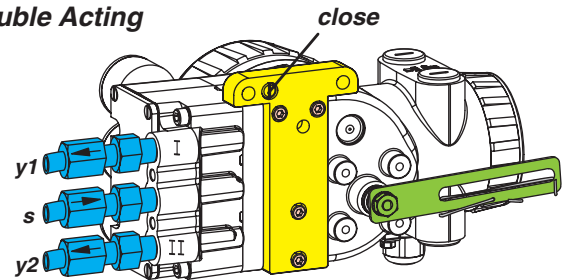

Unused pneumatic connections must be closed off.

## 6 ELECTRICAL CONNECTION

The safety requirements on page 58 must be observed! Different threads can be supplied with cable gland – please verify marking at housing! (See drawing at previous page)

Unused cable entries must be closed with blanking plugs with the appropriate explosion-proof certification (the plastic plugs are only to avoid damage on shipping).

Feed in the bus cable through the gland **1**. The gland is suitable for cable diameters of 6 to 12 mm (0.24 to 0.47 in). Observe the tightness of the cable entry.

Make the electrical connection of the input line at the screw terminals **3b**, whereby with Fieldbus devices no polarity has to be observed. The terminals are suitable for wire cross-sections of 0.3 to 2.5 mm<sup>2</sup> (22 -14 AWG).

For devices with communication:

The shield of the bus connection is

- with conductive cable glands (recommended) directly connected with the housing
- with non-conductive cable glands to be placed onto the inner screw terminal **4**.

**Note:** When connecting shielded cable connect the cable shield on both sides!

(on the positioner as well as on the system side).

For selection of cable, see recommendation for cable types acc. to IEC 1158-2.

For connection to a local ground the internal and external ground terminal **4** can be used.

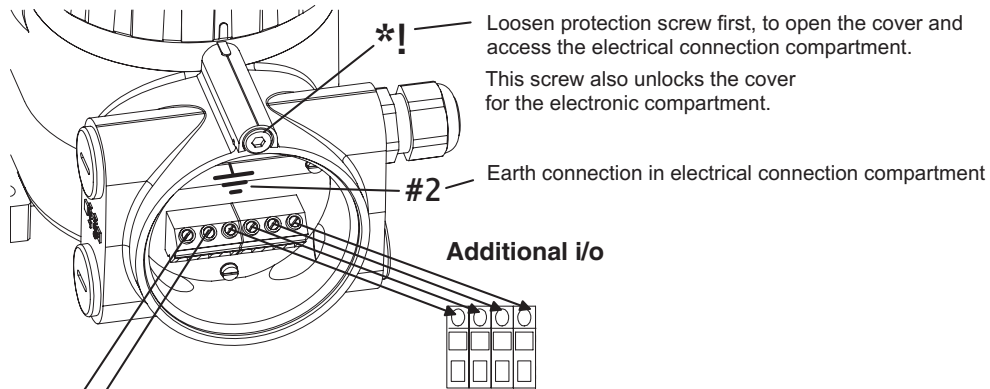

Loosen protection screw first, to open the cover and access the electrical connection compartment.

This screw also unlocks the cover for the electronic compartment.

Earth connection in electrical connection compartment

**Additional i/o**

### Setpoint

For SRD960-xH (HART),  
SRD960-xD (intelligent w/o comm.),  
SRD960-xA (Analog)



Input 4 to 20 mA

For SRD960-xF (FoxCom digital)



Supply voltage ... DC 13 to 36 V

For SRD960-xP (PROFIBUS-PA)  
and SRD960-xQ (FOUNDATION F. H1)



Bus connection acc. to IEC 1158-2  
Supply voltage DC 9 to 32 V

### Two binary outputs (SRD960-xxP) or binary in/output SRD960-xxE

Two-wire system, acc. to DIN 19234  
Supply voltage: DC 8 to 36 V <sup>1)</sup>

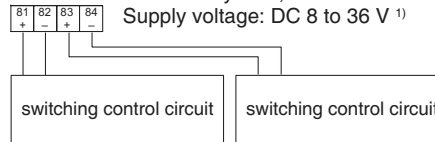

### Two binary inputs (SRD960-xxB)

Binary inputs with internal supply for connection of sensors or switches  
(switch **closed** for a normal operation!)

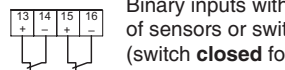

### Position feedback 4 to 20 mA and 1 Alarm (SRD960-xxQ)

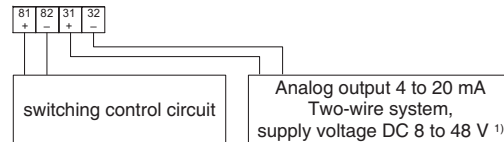

### Inductive Limit Switch (SRD960-xxT or -xxU)

Two-wire proximity sensors,  
acc. to DIN 19234 or NAMUR  
Supply voltage: DC 8 V

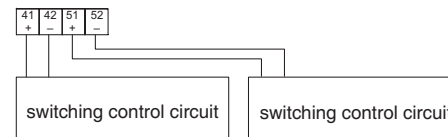

## 7 OPTIONS

### 7.1 “Limit switch” 4

Rebuild to this option resp. exchange see page 51.

#### Switch functions

Feedback lever, feedback shaft and the control vanes are all connected to each other, without an intermediate transmission. The control vanes are therefore moving simultaneously with the same angle rate as the feedback lever. The length of the control vane corresponds with the swing angle of 120°.

Both control vanes are located on different planes. Each control vane can be seen independently from the other, because each has its own sensor (or micro-switch).

By adjusting the screws 1 and 2, the control vanes can be adjusted relatively to the angle rate, so that e.g. one vane dives into and another dives out of the sensor.

#### Testing of switch behaviour

Voltage measuring above the terminals (see page 23):

vane inserted:	approx. 4 V
vane free:	approx. 7 V

(if  $R_i$  of external supply is approx. 1 kOhm)

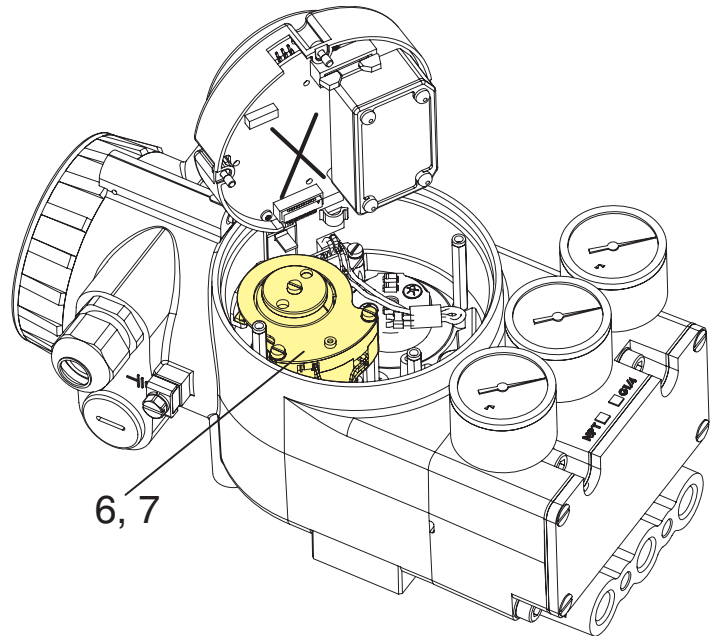

#### Setting limit switch trigger points

First loosen screw **S** until disc **D** is no longer blocked by bolt **B**. Then turn disc by 90°, until set screws **1** and **2** are accessible.

Set trigger point switch GW1:

Turn screw **1** at mark (•), until desired switch behavior is reached.

Set trigger point switch GW2:

Turn screw **2** at mark (••), until desired switch behavior is reached.

To fix switch points turn disc again by 90°, until the bolt catches, then fasten tight the center screw **S**.

Do not touch control vanes during operation,  
danger of injuries!

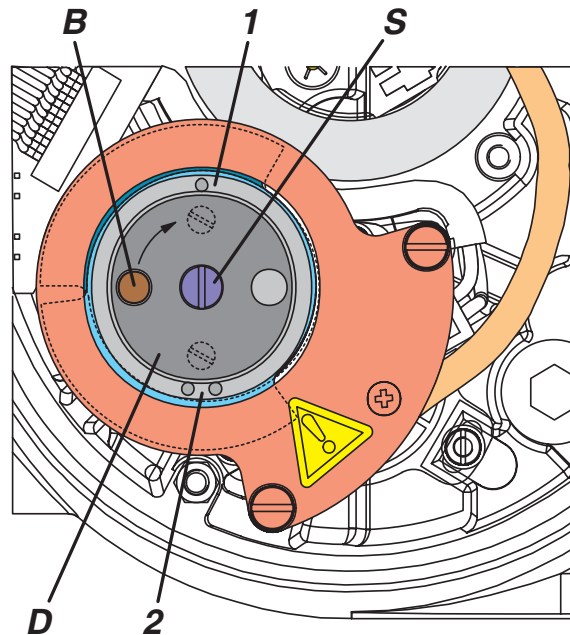



## 7.2 “Additional Inputs / Outputs”

### General

All SRD versions are prepared for a subsequent conversion to this option, if not already installed at the factory. Installation of options, see from page 48 forward.

### Option “Position feedback and alarm”

The **analog** output for **position feedback** indicates the valve position 0 to 100 % as current signal 4 to 20 mA <sup>1)</sup>. Signal range 3.8 to 20.5 mA, at fault approx. 0.5 mA.

The **binary** output for **Alarm** will be activated in the following cases (see Messages, page 54):

- Calibration error (for example due to break-up of calibration) Message 3
- Output outside of limits determined during Autostart (Check mounting of feedback lever) Message 5
- Circuit to potentiometer is disturbed (cable plugged?) Message 5
- Circuit to IP module is disturbed (cable plugged?) Message 6
- No actuator movement; Message 7
- Remaining control deviation (packing is too tight?) Message 11

Signal range: 1 mA resp. 4...6 mA, at fault < 50  $\mu$ A.

During disturbance of the electronics of the SRD the Watchdog circuit is activated. The binary output for alarm signalizes this as “cable failure”. Installation see page 50.

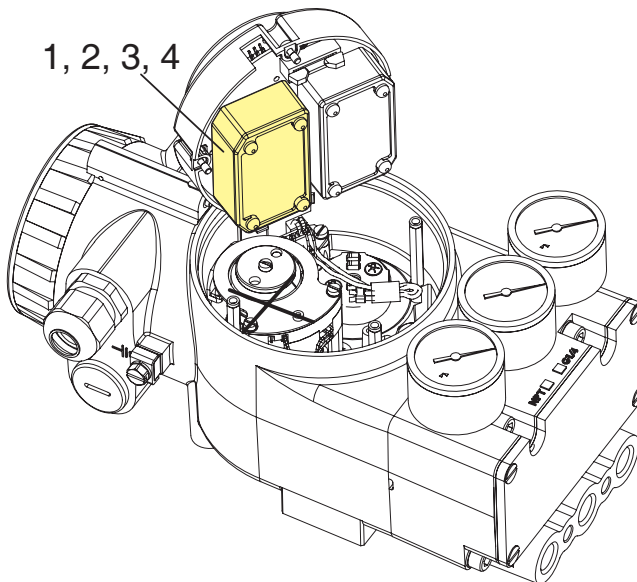

### Option “Two binary outputs” 2

Both binary outputs AB1 resp. AB2 switch to high current as soon as the valve position is below resp. exceeds the associated limit value. If the binary outputs AB1 resp. AB2 are to be inverted (higher current no alarm, lower current alarm), the association upper/ lower alarm have to be exchanged.

Signal range 1 mA resp. 5–6 mA, at fault < 50  $\mu$ A. Installation see page 50.

### Option “Binary inputs”

The binary inputs EB1 and EB2 for two external switches resp. sensors initiate the following actions: <sup>2)</sup>

EB1	EB2	Action <sup>2)</sup>
closed	closed	IN SERVICE
open	closed	Position to be operated full power to 0 %
closed	open	Position to be operated full power to 100 %
open	open	Hold last value

An input not used is to be short-circuited (wire bridge between + and –).

**Attention:** Even if opening limit or closing limit are set: these actions are superimposed, and the actuator actually moves to 0 % resp. 100 %. Installation see page 50.

## 7.3 “Built-in pressure sensors” 5

For monitoring of pressure of supply air, Y1 and Y2 per communication. Installation see page 49.

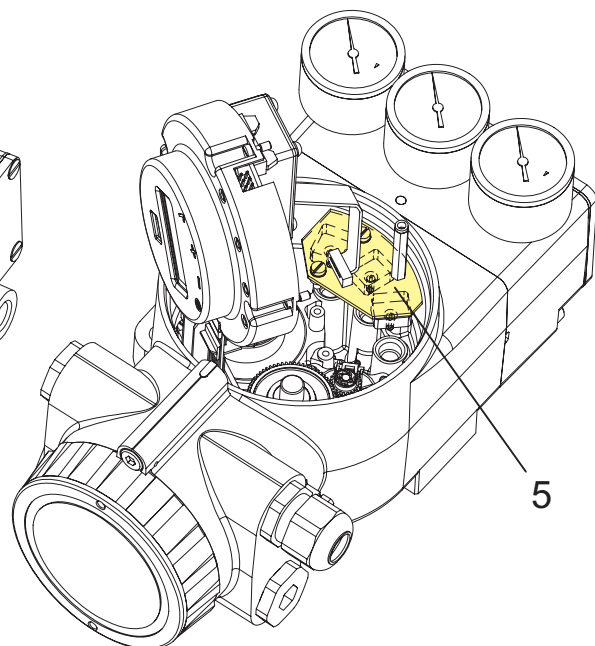

- 1) The direction of action of the position response message is set: valve position 0% = 4 mA; valve position 100% = 20 mA
- 2) Factory setting. Via communication actions may be turned off or used otherwise. EB1 and EB2 can thus also be used as diagnostics inputs.

## 8 START-UP

### 8.1 General

First of all, the nameplate should be checked, especially with respect to indications referring to Ex / non- Ex, input signal, communciation, output signal, single / double acting, additional inputs / outputs.

Before starting the positioner the SRD has to be mounted to the actuator; a corresponding input signal must be adjacent and air supply must be connected. The supply air connection must have sufficient capacity and pressure of 1.4 - 6 bar (20...90 psig) and should not exceed the maximum operating pressure of the actuator.

**Attention:** Configuration using local keys or the communication interface may interfere with operation of the actual process !  
During configuration it is recommended that there is no flow through the valve.

For **first start-up** see next page.

#### Key Cover (optional)

After loosening of screw **A**, the cover **B** can be turned aside and the 4 local keys are accessible.

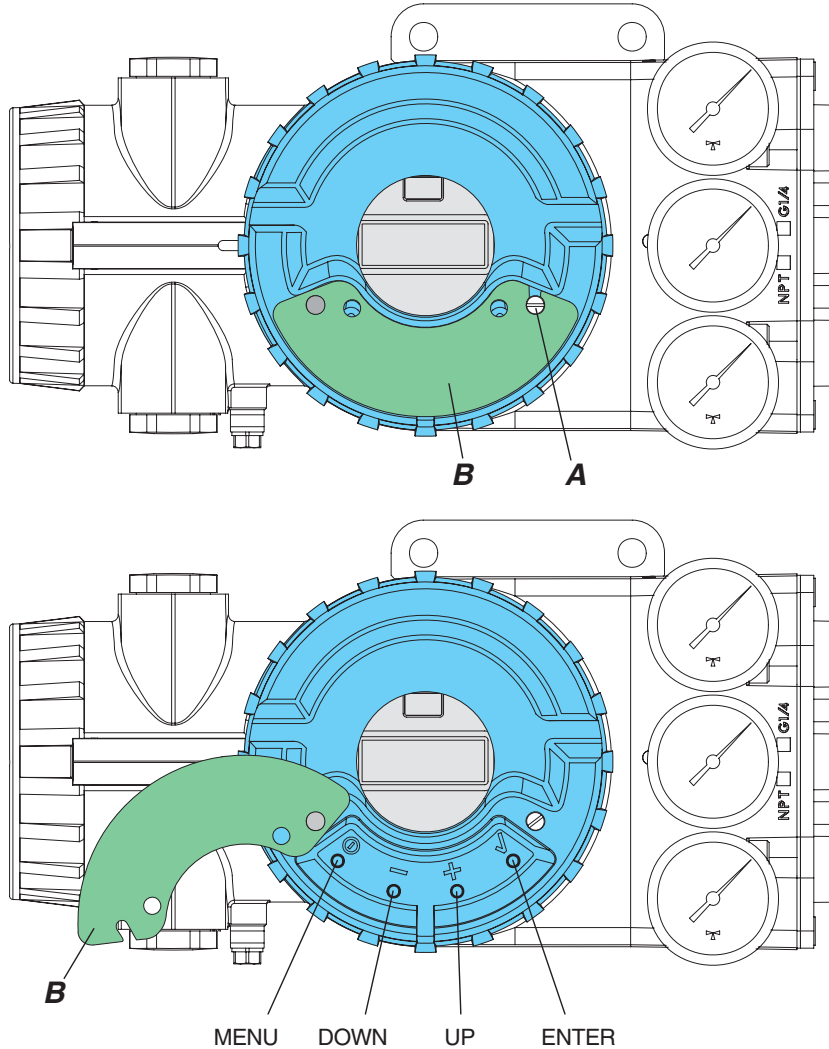

### Setting by means of local keys

The SRD960 can be adjusted by means of local keys (accessible from the outside). The keys have the following function:

- ⓪ start menu / end menu
- (-) counting down of menu or parameter numbers
- (+) counting up of menu or parameter numbers
- ✓ confirm at start, or when entering, storing, or verifying
- ⓪ (-) (+) **simultaneously:**  
Reset = new start of SRD, thereafter initialization

If there is no response using the local key-pad (message 1 appears, see page 54) make shure that the Write Protection is not set ! Remove the write protection using the configuration software.

**Attention:** Do not touch behind the positioner housing while operating the keys!  
**DANGER OF INJURIES!**

### Indication with LCD

In true text:

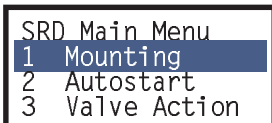

### Indication with LEDs

The LEDs serve as indication in the following different methods:

$\frac{1}{2}$	$\frac{1}{2}$	-	-	-	M and LED 1 flash
---------------	---------------	---	---	---	-------------------

- 1 constant light, ON
- $\frac{1}{4}$  flashing: short ON, long OFF
- $\frac{1}{2}$  flashing: ON and OFF same duration
- $\frac{3}{4}$  flashing: long ON, short OFF
- OFF

## 8.2 OPERATION

### After Power ON

**INIT:** After power on of input signal or after reset, the SRD initialises, thus the various components of the electronic are checked and started. (The stored data of the positioner is of course not affected and remains unchanged).

The current status is stated on the LCD in clear text or indicated as LED code (see page 53).

Initialisation after positioner start-up takes approx. 3 sec, then the SRD goes

- Into operation (Autostart has already been done) or
- To configuration, Menu 1 (with LCD the text language is selected before (changing e.g. to German language) ...

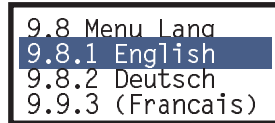

Select with keys (+) or (-) and confirm with (✓).

... and the display orientation is selected ...

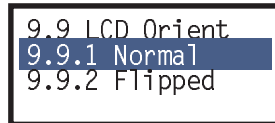

... then automatically continued to configuration:

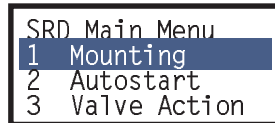

### Configuration

**MENU:** The various specifications for configuration are arranged in menus:

M	LEDs flash				Menu	Description
	1	2	3	4		
1/2	1/2				1	Actuator system, mounting side
1/2		1/2			2	Autostart
1/2			1/2		3	Valve function
1/2				1/2	4	Characteristic of setpoint
1/2	1/2	1/2			5	Limits and Alarms
1/2	1/2		1/2		6	Parameter for position controller
1/2	1/2			1/2	7	Manual setting of pneumatic output
1/2		1/2	1/2		8	Manual setting of valve position
1/2		1/2		1/2	9	Calibration functions for workshop
1/2			1/2	1/2	10	PROFIBUS-PA:Bus Address FOUNDATION F.:Simulate

1/2 = ON and OFF flashing same duration

Details of Menus and Parameters see following pages.

### In Operation

After accomplished autostart, the SRD goes automatically IN OPERATION. (Additional parameters can of course be configured through pressing of menu key (●)).

On the LCD display the process variable is indicated.



(With LED version, all LEDs are off during operation.)

Through pressing of keys (+) or (-) additional information can be retrieved from the SRD:

- Travel position
- Input current
- Digital setpoint
- Stem setpoint
- Output pressure1
- Output pressure2
- Input pressure
- Temperature
- Travel sum
- Valve cycles
- SRD Version

(Certain data is available only with the corresponding options.)

### Manual Operation

Through twice pressing of key (✓), the SRD goes into manual operation mode, where the valve position can be set manually. Exit of menu by pressing twice of (●).

### Diagnostics during Operation

If the diagnostics determines an occurrence, this is indicated in the bottom line: (resp. blinking code with LEDs).



**MESSAGE:** The SRD recognises an occurrence which the user must eliminate by taking suitable steps in order to continue with operation. This can be e.g. a wrong configuration or missing supply air. With key (+) additional information can be retrieved.

**ERROR:** During self-testing the SRD recognised an error and is no longer operable, see page 53.



## Menustucture for SRD991/SRD960 with LCD

Menu	Factory configuration	Description
SRD Main Menu		
1 Mounting		
1.1 Lin left	✓	Linear actuator, left-hand or direct mounting
1.2 Lin right		Linear actuator, right-hand mounting
1.3 Rot cclockw		Rotary actuator, opening counter-clockwise
1.4 Rot clockw		Rotary actuator, opening clockwise
2 Autostart		
2.1 Endpoints		Adaptation to the mechanical stops only
2.2 Standard		Autostart recommended for standard application
2.3 Enhanced		Optimized control behaviour compared to Standard Autostart
2.4 Smooth resp.		Extended Autostart, Dampened control behaviour for e.g. smaller actuators
2.5 Fast resp.		Extended Autostart, Undampened control behaviour for e.g. larger actuators
3 Valve Action		
3.1 Direct	✓	Valve opens with increasing setpoint value
3.2 Reverse		Valve closes with increasing setpoint value
4 Character		
4.1 Linear	✓	Linear characteristic
4.2 Eq Perc 1:50		Equal percentage characteristic 1:50
4.3 Quick open		Inverse equal percentage characteristic 1:50 (quick opening)
4.4 Customer		Custom characteristic
5 Limits/alarms		<i>Not locally available with LED versions of communication FF and Profibus</i>
5.1 Lower limit	0 %	Closing limit is set to input value
5.2 Cutoff low	1 %	0%-tight sealing point is set to input value
5.3 Cutoff high	100 %	100%-tight sealing point is set to input value
5.4 Upper limit	100 %	Opening limit is set to input value
5.5 Splitr 0 %	4 mA	Split range 0 %: input value corresponds to 0 %
5.6 Splitr 100 %	20 mA	Split range 100 %: input value corresponds to 100 %
5.7 Lower Alarm	-10 %	Lower position alarm on output 1 is set to input value
5.8 Upper Alarm	110 %	Upper position alarm on output 2 is set to input value
5.9 Valve 0%	4 mA	Configuration of rated-stroke of 0% at 4 mA
5.10 Valve 100%	20 mA	Configuration of rated-stroke of 100% at 20 mA
5.11 Stroke Range	x° / 20mm	Configuration of nominal travel
5.12 Temp unit	°C	Configuration of the temperature unit °C or °F
6 Parameters		
6.1 Gain closing	15	P: Proportional gain for 'close valve'
6.2 Gain closing	2	p: Proportional gain for 'open valve'
6.3 Res time cl	7.5	I: Integration time for 'close valve'
6.4 Res time op	2.4	I: Integration time for 'open valve'
6.5 Rate lim cl	0.35	T63: Setting time for 'close valve'
6.6 Rate lim op	0.35	T63: Setting time for 'open valve'
6.7 Control gap	0.1	Permitted neutral zone for control difference
7 Output		Manual setting of IP-Module for testing of pneumatic output
8 Setpoint		Manual setting of valve position
8.1 12.5% Steps		Setpoint changes of 12.5% steps by using push buttons Up or Down
8.2 1% Steps		Setpoint changes of 1% steps by using push buttons Up or Down
9 Workbench		
9.1 Reset Config		Resetting of configuration to setting "ex factory"
9.2 Calib. 4 mA		Calibrate input current to 4 mA
9.3 Calib. 20 mA		Calibrate input current to 20 mA
9.4 Calib. -45°		Calibrate position measuring value to -45°
9.5 Calib. +45°		Calibrate position measuring value to +45°
9.6 Reset all 1		Resetting of configuration and Calibration (I) to "ex factory" setting for <b>single-acting</b> output
9.7 Reset all 2		Resetting of configuration and Calibration (I) to "ex factory" setting for <b>double-acting</b> output
9.8 Menu Lang		
9.8.1 English	✓	Standard
9.8.2 Deutsch		Standard
9.8.3 Français		Preselected / Freely Definable
9.9 LCD orient		
9.9.1 Normal	✓	Normal orientation of writing on LCD
9.9.2 Flipped		Reverse orientation of writing on LCD
9.10 Cal. Feedbk		Calibration of output current of position transmitter
9.10.1 Cal 4mA		Calibration of the 0% at 4mA
9.10.2 Cal. 20mA		Calibration of the 100% at 20mA
10 - not available - for HART		
10 Bus adresse - Profibus PA		
10.1 Address LSB		Ratio from Dec. 0 / Hex 00 to Dec. 15 / Hex 0F
10.2 Address MSB		Ratio from Dec. 0 / Hex 00 to Dec. 112 / Hex 70
10.3 Address	126	Display of Bus Address from Dec. 1 to 127 (Hex 00 to 7F)
10 FF Config.		
10.1 Simulate	✓	
Disabled		Simulate disabled
Enabled		Simulate enabled
10.2 Profile		
Link Master	✓	Link Master active
Basic Device		Link Master de-activated

### Additional Parameters

The following parameters are accessible via communication only:

Parameter	ex factory
Control difference limit value	5 %
Control difference response time	1 min
Sealing hysteresis	0.5 %
Failsafe-Aktion	OFF
Power-up action	IN SERVICE
Parameter write protection	OFF
Alarm limit for total strokes	90 Mio.
Alarm limit for total cycles	90 Mio.
Dead band for valve cycles	1 %
Set value source: Model Code xFxx	digital
Set value source: all others	analog
Upper pre-alarm	100 %
Lower pre-alarm	0 %
Hysteresis for position alarms	0.5 %

Complete parameter list see PC20 / PC50 (FDT Software).

### 8.3 Description of menus

Because of optimised local operation, for configuration neither PC nor control system is required.

In case operation via local keys is not possible  
check if write protection is set.  
Change via PC20 / IFDC or PC50 (FDT) software.

#### Menu 1: Actuator system, Mounting side

```
SRD Main Menu
1 Mounting
2 Autostart
3 Valve Action
```

Confirm with key (✓)

```
1 Mounting
1.1 Lin left
1.2 Lin right
1.3 Rot cclockw
```

(Weitere mit der (+) Taste:)

```
1 Mounting
1.1 lin left
1.2 Lin right
1.3 Rot cclockw
```

```
1 Mounting
1.1 Lin left
1.2 lin right
1.3 Rot cclockw
```

```
1 Mounting
1.2 Lin right
1.3 Rot cclockw
1.4 Rot clockw
```

M	1	2	3	4	
½	½	-	-	-	M and LED 1 flash

For an optimal actuator adaptation the SRD has to be configured whether it is a rotary or a stroke actuator.

The positioner of the **rotary** actuator can work directly with the linear position sensor value. In case of a **stroke** actuator an error  $\tan(\alpha)$  arises due to the angle of the resulting in 1% non-linearity at travel of 30°. The SRD is able to recount travel via the tan function and thus avoid bigger linearity errors.

The rotation direction of the adapter shaft for the tap changes depending on the mounting side of the stroke actuator. "Valve closed" in one case means "Valve open" in another one.

There are rotary actuator types opening in the counter clockwise direction and others opening in the clockwise direction. This also has to be signaled to the SRD so that 0% "Valve closed" and 100% "Valve open" are correctly assigned.

-	1	-	-	-	LED 1 lights up
---	---	---	---	---	-----------------

For stroke actuators mounted left of the spindle resp. directly mounted.

-	-	1	-	-	LED 2 lights up
---	---	---	---	---	-----------------

For stroke actuators mounted right of the spindle.

-	-	-	1	-	LED 3 lights up
---	---	---	---	---	-----------------

For rotary actuators opening the valve during counter clockwise (left) rotation.

-	-	-	-	1	LED 4 lights up
---	---	---	---	---	-----------------

For rotary actuators opening the valve during clockwise (right) rotation.

## Menu 2: Autostart

SRD Main Menu
1 Mounting
<b>2 Autostart</b>
3 Valve Action

2 Autostart
2.1 Endpoints
<b>2.2 Standard</b>
2.3 Enhanced

2 Autostart
2.3 Enhanced
2.4 Smooth resp.
<b>2.5 Fast resp.</b>

2 Autostart
SRD960 Vers.xx
Get end points

2 Autostart
SRD960 Vers.xx
Get motor gain

2 Autostart
SRD960 Vers.xx
Control params

2 Autostart
SRD960 Vers.xx
Get valve speed

M	1	2	3	4	
1/2	-	1/2	-	-	M and LED 2 flash

Selection between different Autostart modes  
(change with key (+) or (-) :)

### Autostart:

To automatically adapt the positioner to the valve. Geometric data of the actuator is determined and optimally assigned to control parameters. If the "Standard" Autostart does not result in stable regulation, another Autostart mode - depending upon actuator - should be selected. At **initial start-up**, an Autostart should always be performed.

**Attention:** Autostart overwrites previous control parameters!

### 2.2 Ready for "Standard" Autostart:

-	1	-	-	1	LED 1 and LED 4 lights up
---	---	---	---	---	---------------------------

With key (+) or (-) to other Autostart modes:

### 2.1 Ready for "End points" Autostart:

Serves for automatic adjustment of the SRD to the mechanical end points.

-	-	1	1	-	LED 2 and LED 3 lights up
---	---	---	---	---	---------------------------

### 2.3 Ready for "Enhanced" Autostart:

To the optimization of the controller parameters in relation to standard mode:

-	-	1	-	1	LED 2 and LED 4 lights up
---	---	---	---	---	---------------------------

### 2.4 Ready for "Smooth response" Autostart:

Extended, damped controller parameters for e.g. smaller drives

-	1	-	1	-	LED 1 and LED 3 lights up
---	---	---	---	---	---------------------------

### 2.5 Ready for "Fast response" Autostart:

Extended, undamped controller parameters for e.g. larger drives

-	1	1	-	-	LED 1 and LED 2 lights up
---	---	---	---	---	---------------------------

After selection and start (by pressing the (✓) key) the function taking several minutes can be followed at LCD or the green LEDs. Duration on a valve position can take some time depending on actuator volume, air supply, pressure, etc.

-	1	-	-	-	LED 1 lights up
---	---	---	---	---	-----------------

Moving direction, mechanical starting and ending positions are determined by one or several passages of valve position range.

-	-	1	-	-	LED 2 lights up
---	---	---	---	---	-----------------

Ramps are entered and control system parameter is determined (ratio position/valve size).

-	-	-	1	-	LED 3 lights up
---	---	---	---	---	-----------------

Jumps are entered for determination of control parameters.

-	-	-	-	1	LED 4 lights up
---	---	---	---	---	-----------------

Determination of positioning speeds.

-	-	-	-	-	All LEDs are off
---	---	---	---	---	------------------

Determined values are saved; previous values are superscribed. The SRD is IN SERVICE again with the detected new parameters.



**Menu 3: Valve Action**

```
SRD Main Menu
1 Mounting
2 Autostart
3 Valve Action
```

```
3 Valve Action
3.1 Direct
3.2 Reverse
```

**Menu 4: Characteristic of setpoint**

```
SRD Main Menu
2 Autostart
3 Valve Action
4 Valve Char.
```

```
4 Valve Char.
4.1 Linear
4.2 Eq Perc 1:50
4.3 Quick open
```

```
4 Valve Char.
4.1 Linear
4.2 Eq Perc 1:50
4.3 Quick open
```

```
4 Valve Char.
4.1 Linear
4.2 Eq Perc 1:50
4.3 Quick open
```

M 1 2 3 4  

½	-	-	½	-	M and LED 3 flash
---	---	---	---	---	-------------------

Function of the positioner is set at:

- 1 - - - LED 1 lights up

"Normal" if increasing input signal is to initiate increasing output signal.

- - - - 1 LED 4 lights up

"Reverse" if increasing input signal is to initiate decreasing output signal.

M 1 2 3 4  

½	-	-	-	½	M and LED 4 flash
---	---	---	---	---	-------------------

A relationship between the input signal and valve position is set.

- 1 - - - LED 1 lights up

"Linear"

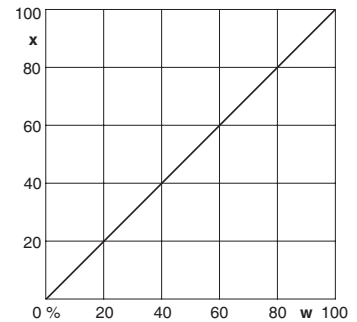

- - 1 - - LED 2 lights up

"Equal percentage":

Results in an equal percentage characteristic line with a position ratio of 1:50 for a valve of linear characteristic.

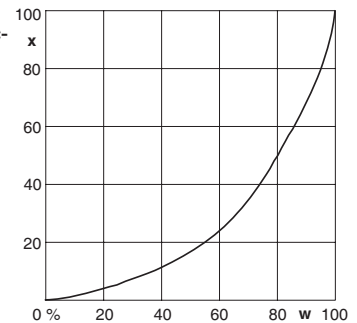

- - - 1 - LED 3 lights up

"Inverse equal perc.":

Results in an inversely equal percentage characteristic line with a position ratio of 50:1 for a valve of linear characteristic.

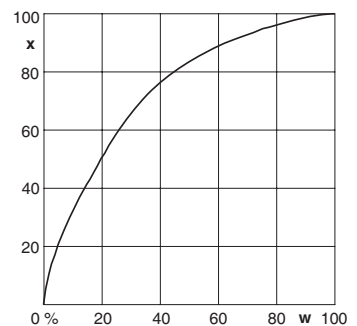

```

4 Valve Char.
4.2 Eq Perc 1:50
4.3 Quick open
4.4 Customer
    
```

```

- - - - 1 LED 4 lights up
    
```

"User defined characteristic":  
 A characteristic line entered via communication (not via local keys) with 2 to 22 supporting points is activated.  
 A linear characteristic is factory set.

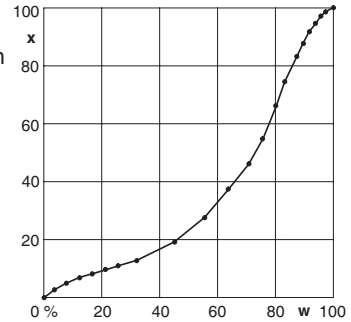

**Menu 5: Limit and Alarms of valve**

```

SRD Main Menu
3 Valve Action
4 Valve Char.
5 Limits/Alarms
    
```

**Notice:**

With versions with LCD, the values can be adjusted stepwise locally in "clear text" with keys (+) and (-).  
 With versions with LED and HART or "without communication", the corresponding current of the valve is rated via analog output and entered with key (✓).  
 With versions LED and fieldbus, the values can be entered only via communication.  
 With versions with communication, the values can be configured also with corresponding software.

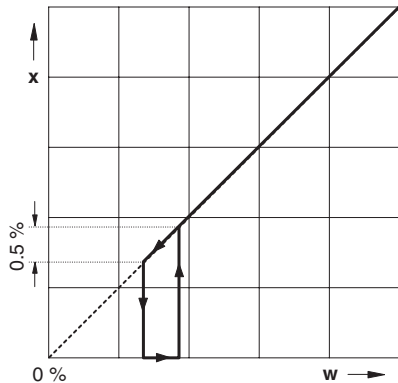

Sealing tightly, linear characteristic line

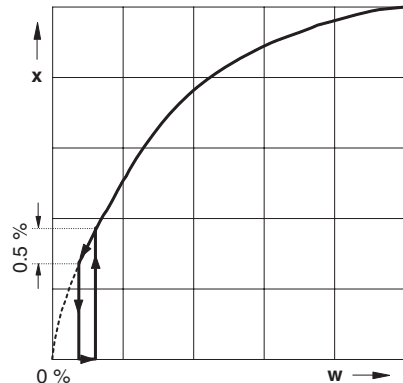

Sealing tightly, inversely equal percentage

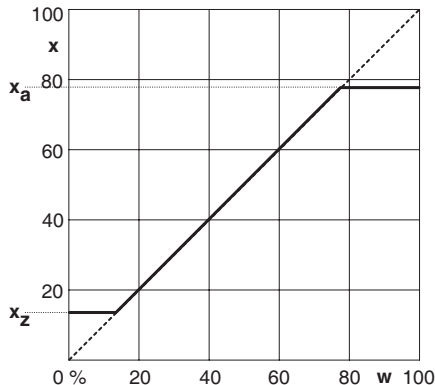

Opening limit  $x_a$ , Closing limit  $x_z$ , linear characteristic

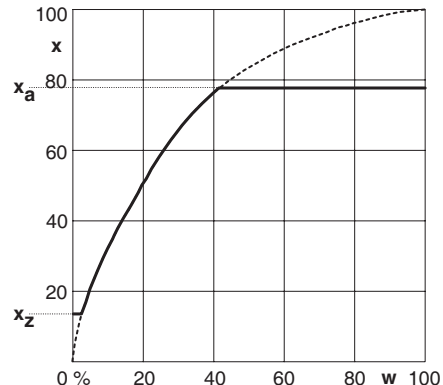

Opening limit  $x_a$ , Closing limit  $x_z$ , inversely equal percentage characteristic

5 Limits/Alarms  
 5.1 Lower limit  
 5.2 Cutoff low  
 5.3 Cutoff high

5.1 Lower limit  
 2.0 %

5 Limits/Alarms  
 5.1 Lower limit  
 5.2 Cutoff low  
 5.3 Cutoff high

5.2 Cutoff low  
 3.0 %

5 Limits/Alarms  
 5.1 Lower limit  
 5.2 Cutoff low  
 5.3 Cutoff high

5.3 Cutoff high  
 97.0 %

5 Limits/Alarms  
 5.2 Cutoff low  
 5.3 Cutoff high  
 5.4 Upper limit

#### 5.1 Setting Lower limit ("closing limit")

-	1	-	-	-	LED 1 lights up
---	---	---	---	---	-----------------

The positioner provides that IN SERVICE the valve position does not close any further than defined by the closing limit. If the setpoint value is lower than this limit, message 12 (see page 55) is produced.

By pressing of keys (+) or (-), the value is adjusted and with key (✓) confirmed. The keys have Autorepeat: By pressing and holding of a key (+) or (-), the value is counted upward, after some time in larger steps.

Example: Lower limit is set to 2 %.

#### 5.2 Setting Cutoff low ("0% seal-tight point")

-	-	1	-	-	LED 2 lights up
---	---	---	---	---	-----------------

If a 0% seal-tight point is given, in case the setpoint is deviated lower (e.g. 3 %), the SRD provides the pneumatic output to press the valve into its seat with full force in order to tightly seal valve.

As soon as the command value is 0.5%\* higher than this seal-tight value, the position again follows the command value.

\* This ist the "Seal-tight hysteresis" factory set at 0.5%. The value may be changed via communication.

#### 5.3 Setting Cutoff high ("100% seal-tight point")

-	-	-	1	-	LED 3 lights up
---	---	---	---	---	-----------------

If a 100% seal-tight point is pre-set and in case a certain set value is exceeded (e.g. 97 %), the SRD provides that the pneumatic output presses the valve 100% into its seat with full force.

This function makes sense for 3-way valves.

Also both seal-tight points can be used in order to tightly close the respective shut-off path during partial operation.

By pressing of keys (+) or (-), the value is adjusted and with key (✓) confirmed. The keys have Autorepeat: By pressing and holding of a key (+) or (-), the value is counted upward, after some time in larger steps.

Example: Cutoff high is set to 97 %.

#### 5.4 Setting Upper limit ("opening limit")

-	-	-	-	1	LED 4 lights up
---	---	---	---	---	-----------------

The SRD provides that IN SERVICE the valve position does not open any further than defined by the opening limit. If the set value is exceeded, message 13 (see page 55) is produced.

### Definitions

**Stroke, stroke range** of the membrane actuator is defined for rotary actuator as **angle, angle range**.

**0 % position** is the mechanical impact at actually closed valve (caution if using handwheel and mechanically adjustable stroke limitation!)

**100 % position** is the mechanical impact at actually open valve.

**Closing limit** is a lower limit set via software. In normal operation the valve will not close more than set here. Attention: In the event of failure of the auxiliary energy no controlling is possible, therefore the springs in the actuator will move the valve into safety position (for single-acting actuator).

**Opening limit** is a upper limit set via software. In normal operation the valve will not close more than set here. Attention: In the event of failure of the auxiliary energy no controlling is possible, therefore the springs in the actuator will move the valve into safety position (for single-acting actuator).

**Normal operation** (= IN SERVICE) means that the position is controlled to the 4–20 mA input signal.

## Split Range

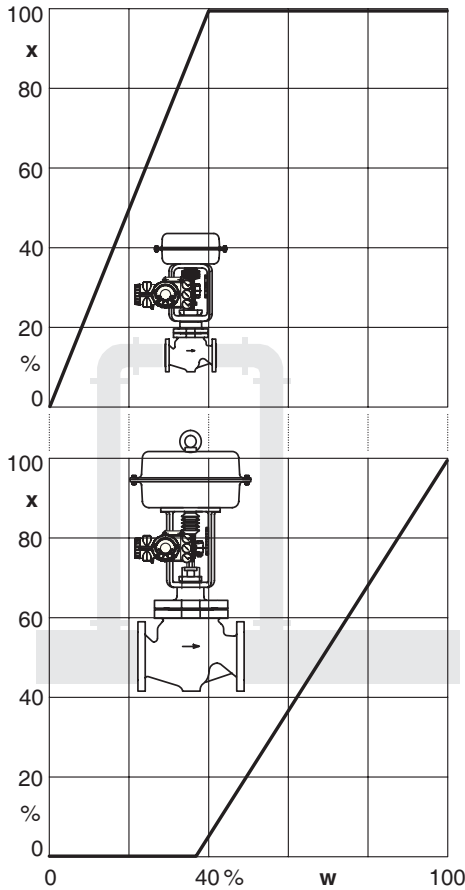

### Split-Range, PV\_Scale Splitting

Split Range is useful if an additional control range is demanded which cannot be covered by one valve only. A valve of smaller nominal size can be applied overtaking the smallest quantities; a parallel mounted valve of bigger nominal size takes on the larger quantities.

With conventional positioners, this function is realised through serial connection of the instruments and allocation of individual regulating ranges (see drawing). With SRD with analogue setpoint value (version HART or "without communication"), this can be adjusted with menus 5.5 and 5.6.

The other versions of the SRD receive the set value via digital means; the input signal cannot be splitted. The function can be realised either in the primary control system, in which own setpoint values are calculated for each valve, or via the variables PV\_SCALE. With PV\_Scale the digital input setpoint value can be assigned to the valve span.

Example: At low current, only the smaller valve positions; from approx. 40 % the large valve is added

### SRD960 with HART or "Without Communication"

(With the other versions of the SRD, these menus cannot be selected.)

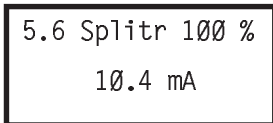
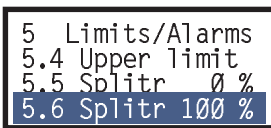
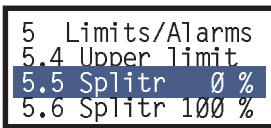

#### 5.5 Split Range 0 %



LED: The value that was adjusted e.g. with a loop calibrator at the input of the SRD, is entered with confirmation of key (✓) as 0 % value.

LCD: By pressing of keys (+) or (-) the value is adjusted and confirmed with key (✓).

#### 5.6 Split Range 100 %



LED: The value that was adjusted e.g. with a loop calibrator at the input of the SRD, is entered with confirmation of key (✓) as 0 % value.

LCD: By pressing of keys (+) or (-) the value is adjusted and confirmed with key (✓).

The keys have Autorepeat: By pressing and holding of a key (+) or (-), the value is counted upward, after some time in larger steps.

Example: An input current of 10.4 mA has to correspond to a valve position of 100 %.

```

5 Limits/Alarms
5.6 Splitr 100 %
5.7 Lower Alarm
5.8 Upper Alarm

```

```

5 Limits/Alarms
5.6 Splitr 100 %
5.7 Lower Alarm
5.8 Upper Alarm

```

```

5.8 Upper Alarm
91.3 %

```

```

5 Limits/Alarms
5.9 Valve 0 %
5.10 Valve 100 %
5.11 Stroke

```

```

5 Limits/Alarms
5.9 Valve 0 %
5.10 Valve 100 %
5.11 Stroke

```

```

5.10 Valve 100 %
98.4 %
Confirm

```

```

5 Limits/Alarms
5.10 Valve 100 %
5.11 Stroke
5.12 Temp unit

```

```

5.11 Stroke
30.0 mm
1 in = 25.4 mm

```

```

5 Limits/Alarms
5.10 Valve 100 %
5.11 Stroke
5.12 Temp unit

```

### 5.7 Setting Lower Alarm

```
- 1 1 - - LED 1 and LED 2 lights up
```

When falling below the set value underneath the entered alarm limit, an alarm is activated. Message 12 is generated.

To switch off the alarm setting, enter the value -10%.

### 5.8 Setting Upper Alarm

```
- - 1 - 1 LED 2 and LED 4 lights up
```

When surpassing the set value above the entered alarm limit, an alarm is activated. Message 13 is generated.

To switch off the alarm setting, enter the value +110%.

By pressing of keys (+) or (-), the value is adjusted and with key (✓) confirmed.

The keys have Autorepeat: By pressing and holding of a key (+) or (-), the value is counted upward, after some time in larger steps.

Example: Upper Alarm set to 91.3 %.

### 5.9 Valve Limits (Not with versions FF/PB/FoxCom with LED display)

At Autostart the SRD determines the real limits of the actuator (which generally are a little larger then specified on the specification sheet). An actuator with 30 mm stroke, could display a real stroke of 33 mm. In order to produce a precise relationship between the input signal and the stroke, the tolerances of the actuator can be compensated with menus 5.9 and 5.10. At unchanged 0 %, the actuator could be moved until exactly 30 mm are reached. Through execution of function 5.10, the current position can be declared as 100 % and at a setpoint value of 50 %, the actuator will run on exactly 15 mm.

For new configuration of the strokes at 0% or 100%, the valve must be run in the corresponding position and then must be confirmed.

### 5.9 Setting Valve 0 %

```
- 1 1 - 1 LED 1, LED 2 and LED 4 lights up
```

The actual position of the actuator is declared as 0 %.

### 5.10 Setting Valve 100 %

```
- - 1 1 1 LED 2, LED 3 and LED 4 lights up
```

The actual position of the actuator is declared as 100 %.

By pressing of keys (+) or (-), the value is adjusted and with key (✓) confirmed.

The keys have Autorepeat: By pressing and holding of a key (+) or (-), the value is counted upward, after some time in larger steps.

Example: The actual valve position 98.4 % is to be counted as 100 %.

### 5.11 Setting Stroke with stroke actuators (only with LCD)

```
- - 1 1 - (LED 2 and LED 3 lights up)
```

The SRD measures with its feedback lever always only an angle and by means of its tangent function, a linear stroke of 0 to 100 % is calculated therefrom. In order to indicate as well a real stroke in mm, the full stroke at 100 % can be entered in this menu. The LCD display will then indicate the actual position in mm/inch.

(Changing of display to "inch" via communication.)

By pressing of keys (+) or (-), the value is adjusted and with key (✓) confirmed.

The keys have Autorepeat: By pressing and holding of a key (+) or (-), the value is counted upward, after some time in larger steps.

Example: Stroke range of valve is to be 30 mm.

### 5.12 Temperature unit (only with LCD)

Selection of temperature indication in °C or °F.

**Menu 6: Parameter for Position controller**

Along with the determination of the actuator geometry and control parameters the suitable setting parameters for the position controller are determined via function AUTO- START in Menu 2. Assessment of a control behavior generally is very subjective. Partially a quick response is requested without consideration of the overshoot width, partially a very smooth swinging is requested with minor overshoot.

We basically recommend to first perform the execution of the automatic setting via AUTOSTART in Menu 2 in order to achieve a stable control behavior. Corrections may then be made from the determined values. In rare cases AUTOSTART cannot find the optimal setting for the respective application. See "Remarks for controller optimization" following table 4.

For small actuators an improvement of the control behavior can be achieved also by increasing damping at the pneumatic output (see page 47). A further optimization may follow by repeating AUTOSTART.

SRD Main Menu
4 Valve Char.
5 Limits/Alarms
6 Parameters

M	1	2	3	4	
½	½	-	½	-	M, LED 1 and LED 3 flash

Seven control parameters are combined in Menu 6 each availing of a sub-menu. 15 different values may be selected in each of these and pressing of (✓) be entered in the position controller as constant. Controller type is a PI controller.

Parameter-Designation	Valve is opening	Valve is closing	Unit
Proportionate amplification KP	P↑	P↓	-
Integration time constant	Tn↑	Tn↓	sec
Positioning time	T63↑	T63↓	sec
Dead band for control diff.	GAP	GAP	% of span

The dead band prevents (at the expense of accuracy) that the valve in the controlled condition constantly moves around the setpoint. This less harms the mechanical parts of the actuator and in particular the valve packing.

**Selection of sub-menus:**

M	1	2	3	4	
¼	-	¾	-	-	M, LED 2 flash: P↓
¼	¾	¾	-	-	M, LED 1 and LED 2 flash: P↑
¼	-	-	¾	-	M, LED 3 flash: Tn↓
¼	¾	-	¾	-	M, LED 1 and LED 3 flash: Tn↑
¼	-	-	-	¾	M, LED 4 flash: T63↓
¼	¾	-	-	¾	M, LED 1 and LED 4 flash: T63↑
¼	-	¾	¾	-	M, LED 2 and LED 3 flash: GAP

Following selection of the sub-menu the codes for the parameter values (table 4) can be selected by pressing (✓) :

6 Parameters
6.1 Gain closing
6.2 Gain opening
6.3 Res time cl

etc.

6 Parameters
6.4 Res time op
6.5 Rate lim cl
6.6 Rate lim op

6 Parameters
6.5 Rate lim cl
6.6 Rate lim op
6.7 Control gap

Table 4: Allocation of the parameter values to coding:

Code	LEDs 1 2 3 4	In LCD shown values: [in Menu Nr.]			
		P↑ [6.1] P↓ [6.2]	Tn↑ [6.3] Tn↓ [6.4] (sec)	T63↑ [6.5] T63↓ [6.6] (sec)	Dead band [6.7] (%)
1	1 0 0 0	2	1	0.1	0
2	0 1 0 0	2.66	1.33	0.15	0.12
3	1 1 0 0	3.50	1.75	0.25	0.16
4	0 0 1 0	4.7	2.4	0.35	0.22
5	1 0 1 0	6.3	3.2	0.5	0.3
6	0 1 1 0	8.4	4.2	0.75	0.4
7	1 1 1 0	11.2	5.6	1.15	0.53
8	0 0 0 1	15	7.5	1.75	0.7
9	1 0 0 1	20	10	2.6	0.94
10	0 1 0 1	26.6	13.3	3.9	1.25
11	1 1 0 1	35.5	17.8	5.9	1.67
12	0 0 1 1	47.3	23.7	8.85	2.22
13	1 0 1 1	63.1	31.6	13.3	2.96
14	0 1 1 1	84.2	42.1	20	3.95
15	1 1 1 1	112.2	- off -	30	5.3

**Remarks to Controller Tuning**

If AUTOSTART does not find the optimum setting the following may be the result:

- A) small response to setpoint, long positioning time or long neutral time
- B) continuous oscillation following setpoint jump
- C) wide and high overshoot

For the assessment of the control 12.5 % jumps in both directions may be performed in Menu 8. The valve dynamics may be observed at LCD or the mechanical indicator.

Prior to changing parameters for valve dynamics a number of items are to be checked, see below. The pneumatic output can be approached directly without controller via Menu 7 and the valve movement may be assessed.

In case of behavior A) check:

1. Is the Proportionate gain P↑ (Menu 6.1) or P↓ (Menu 6.2) too small?  
Remedy: Increase parameters according to chart 4.
2. Is the air pressure high enough to possibly overcome trouble-free the actuator spring force and friction (dimensioning)?  
Remedy through increasing air pressure.
3. Is the actuator volume high, possibly requiring an increased air capacity for fast valve movement?  
Remedy: through booster, see accessories.

(Continued on next page)

4. Was AUTOSTART performed in Menu 2 and did messages 8 resp. 9 occur (messages, see table page 41)?  
Remedy: "AUTOSTART" in Menu 2 resp. observe information in table, page 41.
5. Has the parameter for the positioning time been set at a value too high?  
Remedy: decrease both parameters "T63" in Menu 6.5 or 6.6 .
6. Is valve packing too tight resulting in a very high friction?
7. Is the supply air filter blocked?  
Remedy - see page 47.
8. Has the supply air been contaminated by small oil drops resp. particles or are pneumatic parts possibly blocked?  
Remedy: exchange of pneumatic parts; possibly use a suitable air supply station.

Behaviors B) and C) check:

1. Has the air supply pressure been set too high?  
Remedy: reduce pressure resp. install pressure reducer.
2. Is the proportional amplification in Menu 6.1 or 6.2 too high? The values can possibly be at Code 15.  
Remedy: In such a case, reduce e.g. to Code 10.
3. Is the air capacity possibly too high, e.g. through spool valve or booster?  
Remedy: Work, if necessary, without booster resp. use version without spool valve.

Changing valve dynamics during behavior A):

If valve has a high friction (for example, often the case in small rotary actuators due to low air supply pressure or due to a valve seat packing which is too tight) then the valve position gets stuck after a setpoint jump and possibly is re-controlled via the resetting time  $T_n$ , possibly after quite some time has elapsed.

Basically, the following is possible:

- a) to accept a remaining deviation
- b) to accept some response procedures (such as remaining in over-response for a short time, and remaining below setpoint and trailing).

When deciding a), " $T_n$ " should become ineffective, table value (15). Compensating " $P(kp)$ " should be increased until the setpoint jumps reach the setpoint within a short period of time and without significant over-response (adapt to both movement directions).

When deciding b) start as in a) above. Thereafter " $T_n$ " is reswitched and decreased until the setpoint deviation has been re-controlled within a short period of time and without long after-response (adapt in both movement directions). It is recommended to maintain the  $T_n$ 's for both directions about the same.

If a post oscillation occurs after a setpoint jump, " $T_n$ " is selected too small, possibly " $P(kp)$ " was selected too large.

The positioning time "T63", also called valve damping, does not have an effect during AUTOSTART in Menu 2, however, setpoint jumps in Menu 8 reach the position controller in a damped condition which then is not easily stimulated to oscillation. This behavior is also true for the setpoint input. This enables setting the controller to higher " $P(kp)$ " values without producing oscillations in the process. On one side this helps the position control to level disturbances due to friction, changes in load or air supply pressure changes faster. On the other hand it helps the superimposed valve control circuit that neutral times in the valve control route do not have such a big effect (stability in valve control circuit).

Changing valve dynamics during behavior B):

Increase " $T_n$ " for both movement directions, possibly turn-off and proceed as described in behavior A) alternative b).



**Menu 7: Pneumatic output** (for trouble-shooting)

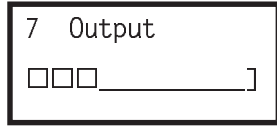
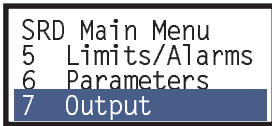

etc.



Serves to check the pneumatic parts of the positioner by directly applying current to the IP module (no control; software limit values such as “stroke limits” or “tight closing” are ignored).

The current of the IP module is increased by about 3% in 32 steps. By measuring the output pressure generally the following characteristic line of the IP module is achieved. The ramp also may be more steep or flat depending on the air supply pressure.

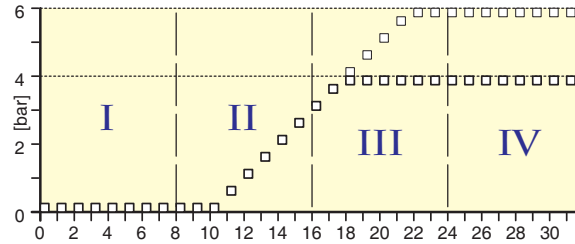

The pneumatic works precisely, if the actuator begins movement in section II and runs latest in section IV into the end position.

If no reaction is shown, check:  
 - does air supply exist? - is plug connected to IP module?  
 If these items are okay, possibly the electronics or a pneumatic part is defect. See also page 47.  
 After leaving this menu (by pressing the **(i)** or **(✓)** key) the actual setpoint is automatically restarted.

**Menu 8: Manual setting of valve position**

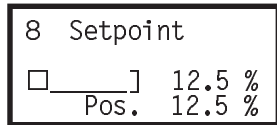
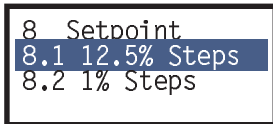

etc.



For the purpose of checking the control reaction of the actuator to a setpoint jump can be observed via the indicator. As far as the device is IN SERVICE the **(+)**/**(-)** keys can initiate jumps of 12.5 % (or 1 %) each. The starting value for Menu 8 is always the current setpoint value.

If the control behavior is to be improved, this can be reached by performing a complete Autostart (see Menu 2) or through manual tuning (see Menu 6).

After leaving this menu the existing setpoint value at the input is automatically restarted.

This menu point can also be called up under normal operating conditions, by twice pressing of key **(✓)**.

## Menu 9: Calibration functions (for workshop)

SRD Main Menu
7 Output
8 Setpoint
9 Workbench

9 Workbench
9.1 Reset Config
9.2 Calib 4 mA
9.3 Calib 20 mA

The following calibration functions must only be performed by trained personnel.

### SRD960 with HART or “Without Communication”

9 Workbench
9.1 Reset Config
9.2 Calib 4 mA
9.3 Calib 20 mA

9 Workbench
9.1 Reset Config
9.2 Calib 4 mA
9.3 Calib 20 mA

9 Workbench
9.4 Calib -45°
9.5 Calib +45°
9.6 Reset all 1

9 Workbench
9.4 Calib -45°
9.5 Calib +45°
9.6 Reset all 1

M	1	2	3	4	
½	-	½	-	½	M, LED 2 and LED 4 flash

Factory calibrations are carried out with sufficient accuracy and remain unchanged during life time. However, an alignment may become necessary in some cases after servicing hardware components.

### 9.1 Reset Configuration to “ex factory” settings

-	1	-	-	-	LED 1 lights up
---	---	---	---	---	-----------------

It is possible to restore the configuration existing at time of delivery via this function. This may become necessary if it is unclear what had been changed per menu or in the event that a positioner was taken from one actuator and mounted to another actuator.

Following this function the device is turned to condition OUT OF SERVICE. This has to be followed by Autostart for the purpose of adapting the calibration to the actuator and to start IN SERVICE.

The parameters of the factory setting are listed in table Menu Structure (page 29).

The calibration of the input current or position sensor makes sense, if after exchange of the electronic, the valve position is inaccurately displayed.

**Calibration of input current** (Only with SRD with analog setpoint; does not apply to fieldbus instruments.)

Serves to equalise possible inaccuracies in the complete current loop.

### 9.2 Calibration of input current to 4 mA

-	-	1	-	-	LED 2 lights up
---	---	---	---	---	-----------------

The present input current value is taken over as “4 mA” when pressing (✓) key.

### 9.2 Calibration of input current to 20 mA

-	1	1	-	-	LED 1 and LED 2 lights up
---	---	---	---	---	---------------------------

The present input current value is taken over as “20 mA” when pressing (✓) key.

### Calibration of position sensor (angle calibration)

The angle pertaining to the vertical tap position (arrow mark) is factory calibrated for the position tap. If the position sensor or the electronics board is exchanged the mechanical and electric tolerances have to be aligned through recalibration. See page 52.

### 9.4 Calibration of position sensor value to -45°

-	-	-	1	-	LED 3 lights up
---	---	---	---	---	-----------------

The present position value is taken over as angle -45° when pressing (✓) key.

### 9.5 Calibration of position sensor value to +45°

-	1	-	1	-	LED 1 and LED 3 lights up
---	---	---	---	---	---------------------------

The present position value is taken over as angle +45° when pressing (✓) key.

```

9 Workbench
9.6 Reset all 1
9.7 Reset all 2
9.8 Menu Lang

```

```

9 Workbench
9.6 Reset all 1
9.7 Reset all 2
9.8 Menu Lang

```

### Configuration functions for all SRD versions with LCD

```

9 Workbench
9.6 Reset all 1
9.7 Reset all 2
9.8 Menu Lang

```

```

9.8 Menu lang
9.8.1 English
9.8.2 Deutsch
9.9.3 (Français)

```

```

9 Workbench
9.7 Reset all 2
9.8 Menu lang
9.9 LCD Orient

```

```

9.9 LCD Orient
9.9.1 Normal
9.9.2 Flipped

```

```

9.9.2 Flipped
9.9.1 Normal
9.9 LCD Orient

```

```

9 Workbench
9.8 Menu Lang
9.9 LCD Orient
9.10 Cal. Feedb

```

```

9.10 Cal. Feedb
9.10.1 Cal. 4mA
9.10.2 Cal. 20mA

```

### 9.6 Resetting of Configuration and Calibration to “ex factory” settings

For the exchange of the electronics the device must be configured whether the pneumatic output is single-acting or double-acting so that the controller shows the correct behavior during the next start-up.

**Caution:** The current calibration for inputs and outputs, the angle calibration and all other calibrations are reset to their factory defined condition!

### 9.6 Resetting of Configuration and Calibration to “ex factory” settings – for single-acting pneumatic output

```

- - - - 1 LED 4 lights up

```

The factory calibration for single-acting pneumatic output is restored when pressing (✓) key.

### 9.7 Resetting of Configuration and Calibration to “ex factory” settings – for double-acting output

```

- 1 - - 1 LED 1 and LED 4 lights up

```

The factory calibration for double-acting pneumatic output is restored when pressing (✓) key.

### 9.8 Selection of menu language <sup>1)</sup>

One of three of the programmed languages can be selected (only with version with LCD display)

Ex-factory the active language is always English. Changing to one of the other two languages, can also take place during operation.

The third menu language can be selected and was already programmed in the factory according to customer order. If a different third menu language is desired, then the language file can be downloaded from our website:

<http://www.foxboro-eckardt.com/download/PLFselector.htm>

Thereafter download the file from the PC via PC20 / PC50 (FDT-Software) onto the SRD. See also references on the internet page. (PC20: EDIT / Change Text Language / Select: File \*.PLF)

### 9.9 LCD Orientation <sup>1)</sup>

Display normal or turned by 180°.

### 9.10 Calibration of Option "Position Feedback 4-20 mA")

Connect 24 V DC to the terminals of this option (see page 23) and insert a precise ampmeter into this loop.

Selecting "Cal. 4 mA" should result a current of 4 mA. Calibrate with keys (+) or (-). Confirm with key (✓).

Selecting "Cal. 20 mA" should result a current of 20 mA. Calibrate with keys (+) or (-). Confirm with key (✓).

1) The menus 9.8 and 9.9 appear automatically at initial start-up, i.e. if the SRD is connected the first time to the electrical supply.

**SRD960 with PROFIBUS PA:**

**Menu 10: Bus Address**

```
SRD Main Menu
8 Setpoint
9 Workbench
10 Bus address
```

```
10 Bus address
10.1 Address LSB
10.2 Adresse MSB
10.3 Address
```

```
10 Bus address
10.1 Address LSB
10.2 Adresse MSB
10.3 Address
```

```
10.2 Address MSB
Dec: 48 Hex: 30
Upper 3 bits ±16
```

```
10 Bus address
10.1 Address LSB
10.2 Address MSB
10.3 Address
```

```
10.3 Address
Dec:126 Hex: 7E
```

M	1	2	3	4	
½	-	-	½	½	M, LED 3 and LED 4 flash

Here the bus address of the SRD can be indicated and changed. The bus address is in the value range of 0 to 127; for the display 7 bits are required. Each bit has a specific value (bit 1=1, bit 2=2, bit 3=4, bit 4=8, bit 5=16, bit 6=32, bit 7=64). The bus address is then the total of the individual values.

To display this with 4 LEDs, selection must be made between the lower and upper 4 bits (whereby the highest bit 8 has no usage and is always 0).

**10.1 Selection of lower 4 bits:**

¼	¾	-	-	-	M short flash, LED 1 long flash
---	---	---	---	---	---------------------------------

With (+) or (-) keys to selection of upper 4 bits:

**10.2 Selection of upper 4 bits:**

¼	-	-	-	¾	M short flash, LED 4 long flash
---	---	---	---	---	---------------------------------

Upon selection, the bits are displayed. When moving (+) or (-) keys, the value is always changed by 1. Pressing (✓) key, the newly entered address will be activated.

The bus address is the total of the individual values:

Values of the **lower** 4 bits and the **upper** 4 bits:

-	[1]	[2]	[4]	[8]	Value of the bits	-	[16]	[32]	[64]	-	Value of the bits
-	-	-	-	-	0	-	-	-	-	-	0
-	1	-	-	-	1	-	1	-	-	-	16
-	-	1	-	-	2	-	-	1	-	-	32
-	1	1	-	-	3	-	1	1	-	-	48
-	-	-	1	-	4	-	-	-	1	-	64
-	1	-	1	-	5	-	1	-	1	-	80
-	-	1	1	-	6	-	-	1	1	-	96
-	1	1	1	-	7	-	1	1	1	-	112
-	-	-	-	1	8						
-	1	-	-	1	9						
-	-	1	-	1	10						
-	1	1	-	1	11						
-	-	-	1	1	12						
-	1	-	1	1	13						
-	-	1	1	1	14						
-	1	1	1	1	15						

Note: Addresses 0 and 127 should not be used. Address 126 (delivery condition) is not permitted for cyclical operation. For further information see TI EVE0105 P.

In the version with LCD indicator, the address is displayed in decimal and hexadecimal number system.

**10.3 Address**

With LCD indicator, this function is recommended, whereby the address can be completely entered, without separation in LSB and MSB. The keys have Autorepeat: By pressing and holding of a key (+) or (-), the value is counted upward, after some time in larger steps.

**SRD960 with FOUNDATION Fieldbus:****Menu 10: Simulate to release / block**

SRD Main Menu
8 Setpoint
9 Workbench
10 Simulation

10 Simulation
10.1 Disabled
10.2 Enabled

M	1	2	3	4	
1/2	-	-	1/2	1/2	M, LED 3 and LED 4 flash

The SRD960 sends during normal operation its actual Position-Actual-Value<sup>1)</sup> back to the control system.

If, however, "Simulate" is released in the SRD and in addition via communication Simulate is activated, then a simulation value coming from the control system is sent back as an actual value to the control system. In this way within the control system, e.g. the reaction to specific valve adjustments can be tested without having to adjust the valve – the SRD regulates toward the "accurate" setpoint value.

For further information about the Simulate see TI EVE0105 Q.

**10.1 Simulate Disabled**

-	1	-	-	-	LED 1 lights up
---	---	---	---	---	-----------------

Block simulate. The actual valve position will be indicated.

**10.2 Simulate Enabled**

-	-	-	-	1	LED 4 lights up
---	---	---	---	---	-----------------

Release simulate.

By using the (+) or (-) keys the desired condition can be selected and entered through pressing of (✓) key.

1) With the option "Position Feedback", the position-actual-value will be displayed, as before, as analog value 4-20mA.

## 9 DECOMMISSIONING

Before decommissioning the unit, disconnect the supply air and the electrical input signal.

After disconnecting the electrical input signal the last confirmed configuration of the positioner is preserved in the memory.

### **Exchange of device**

If a temporary decommissioning of the SRD and a later mounting to another actuator has to be carried out, before disconnecting, we recommend to Reset Configuration in Menu 9.1. So the default settings "Ex-Factory" are re-activated. This facilitates a later recommissioning.

## 10 MAINTENANCE

The SRD960 requires no periodical maintenance. When replacing components during repair work, the safety requirements on page 58 must be observed!

### 10.1 Service plug and IrCom

All basic instruments of the SRD960 are equipped with a service plug **A**. There via RS232 a PC with PC20 / PC50 (FDT-Software) can be connected via modem EDC82 (galv. separated, not Ex).

This universal interface, together with the PC software, allows the configuration of all SRD versions independent of the protocol – thus versions HART, FOUNDATION Fieldbus, PROFIBUS PA, FoxCom and also the version "without communication" can be configured from the PC, without having to acquire expensive modems. For details see TI to EDC82.

The service plug (6 pole pin strip) is accessible from the side after unscrewing of cover to electronic compartment. The 6-pole connector links EDC82 modem with SRD, and from EDC82 a 9 pole subD cable links to RS232 interface of PC.

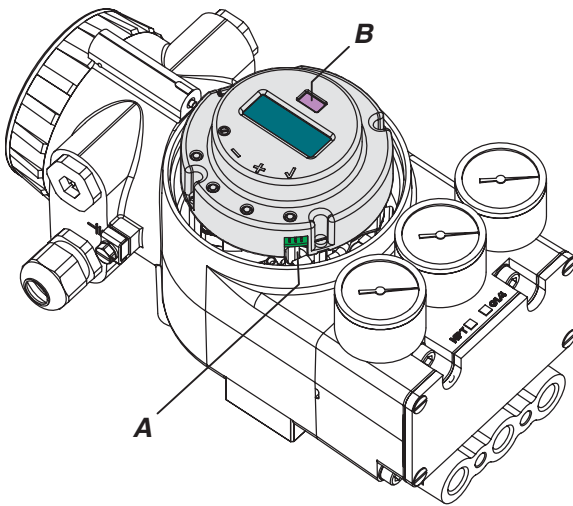

If the SRD is equipped with option "IrCom" **B**, communication can take place contactless via infrared with the positioner (even with closed cover!). Modem "IR Interface" (not Ex) is connected via RS232 to a PC (for practical reasons a notebook) with software PC20 / PC50 and makes possible a range of approx. 1 m.

(If the notebook has an IrDa interface, this cannot be used, despite similar technique. The IrDa instruction set has no communication instructions for positioners.-)

### 10.2 Supply filter replacement

An obstructed supply filter can be replaced. Unscrew the air supply fitting, remove the filter and exchange the filter with a new one.

### 10.3 Pneumatic Amplifier

Upon unscrewing of lateral cover, the pneumatic compartment is accessible.

Fig.: single-acting amplifier

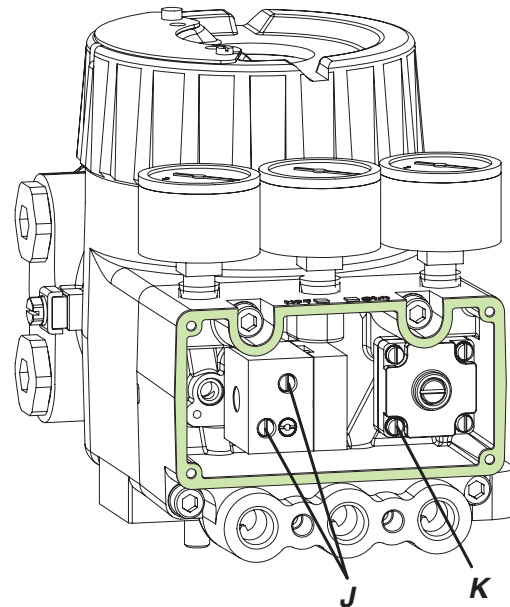

Pre-Amplifier: Unscrew 4 screws **K**.

Amplifier: Unscrew 2 screws **J**.

When remounting, verify the correct seating of sealings.

#### Damping screws (Service only)

The damping screws are adjusted optimal ex-factory; the screw head is even with the amplifier surface. Generally this is the most favorable setting, without damping.

### 10.4 Replacement of mechanical and pneumatic units

See following pages.

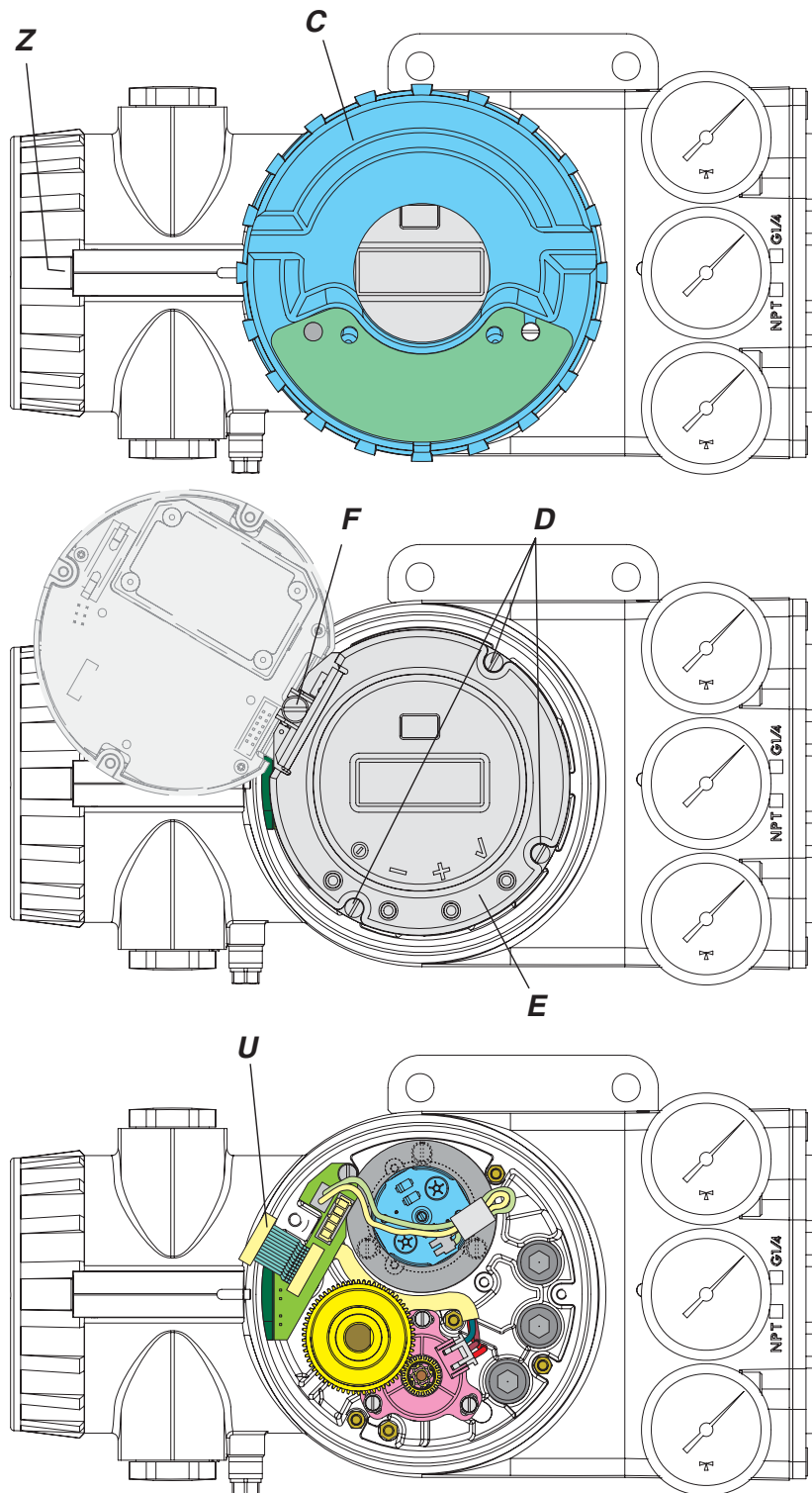

## Open Housing

Unscrew cover safety lock **Z** until cover **C** is completely free.

Then unscrew cover **C**.

## Tilt Electronic forward

Unscrew the 3 screws **D**, and the round electronic **E** can be tilted forward.

Should the electronic have to be removed completely, then unscrew also screw **F**, and pull out plug **U** from the electronic.

When removing (and when re-inserting), the correct position of the flat cables must be observed.

Electronic **E** detached.

Upon exchange of the electronic **E**, the angle calibration (page 52) and an Autostart must be performed!



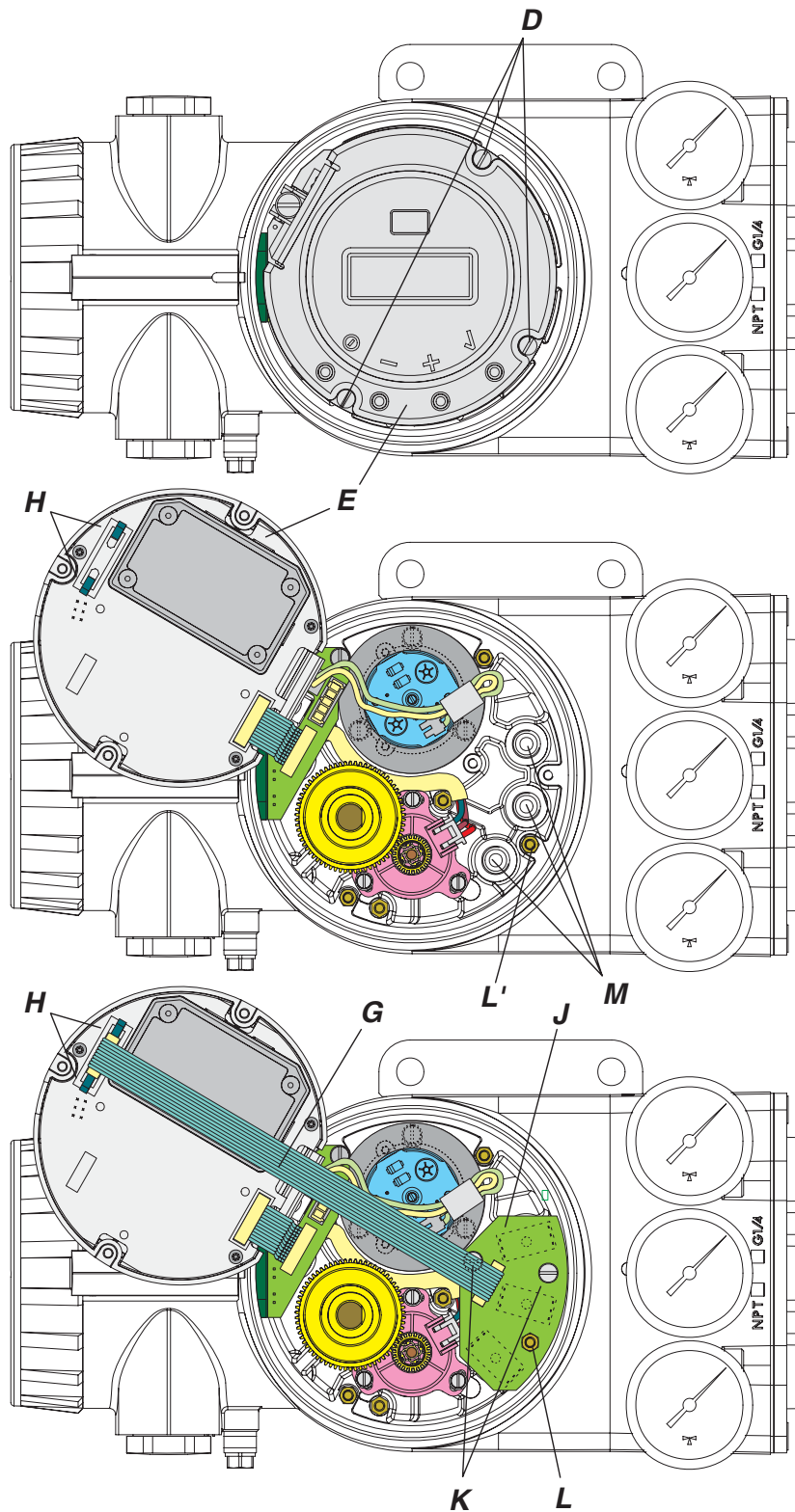

### Option “Pressure Sensors”

Upon unscrewing of the 3 screws **D**, tilt carefully forward the round electronic **E** – if pressure sensors are already built-in, the flat cable **G** must be removed first. For this, unlock the two retaining clips **H** and remove plug.

Secure the “Pressure Sensors” assembly **J** with the two screws **K** and bolt **L**.

When retrofitting to this option, the sealing screws in the measuring holes **M** must be removed, and the (existing) bolt **L** must be exchanged for the (a little shorter) bolt **L'** (1.6 mm level difference through the circuit board).

During mounting, it must be observed that the conical nipples of the reducing bushings are correctly fitted and the 3 measuring holes **M** are free.

Place flat cable **G** and lock connector with retaining clips **H**.

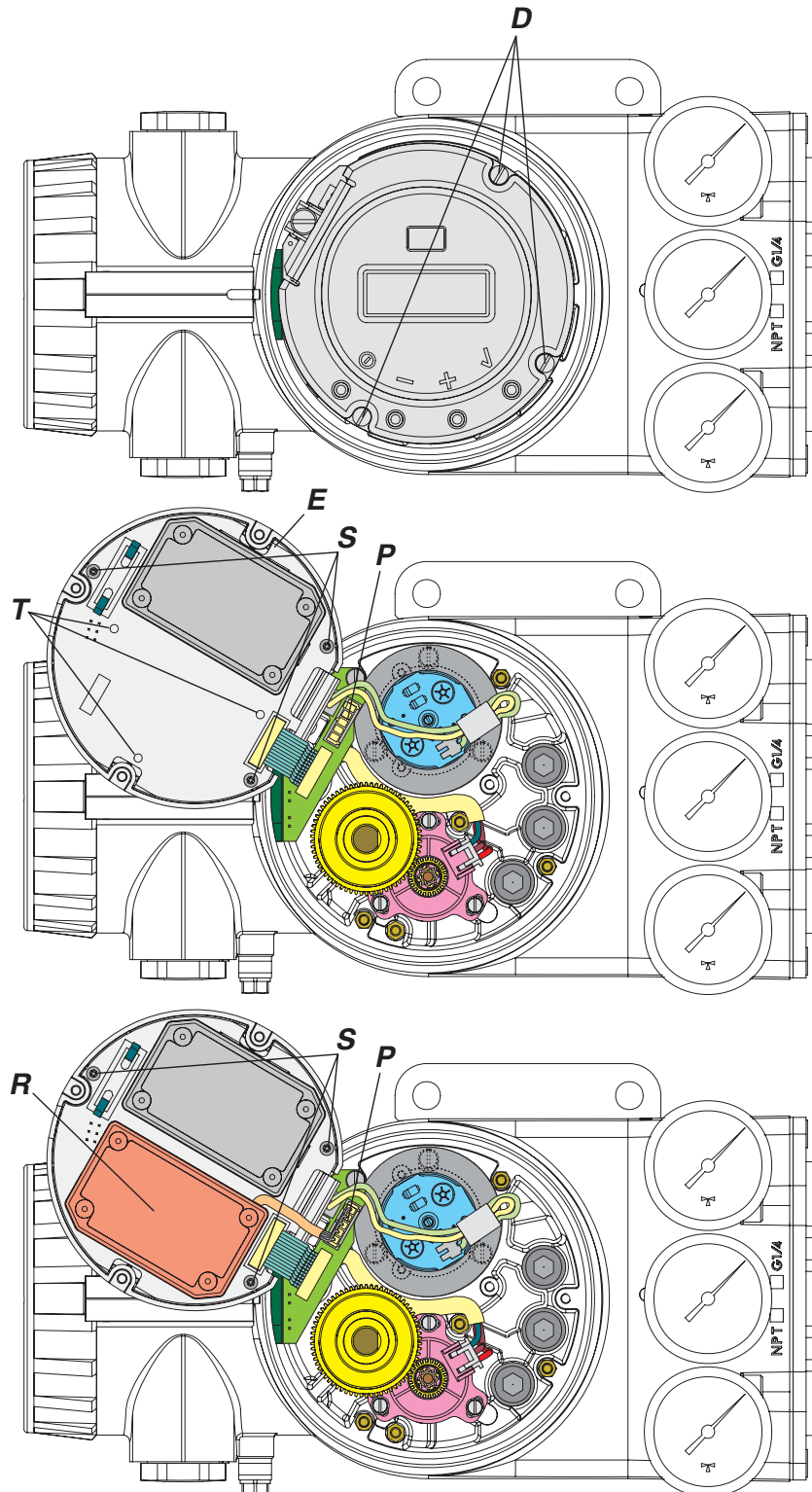

### Option boards “Additional Inputs / Outputs”

Open as described before.

Such an additional module **R** is attached from the “User Side” of the electronic **E** with 3 screws **T**. For removal (or insertion), the round electronic **E** must be taken out of the plastic shell. Unscrew the 3 screws **S** to do this.

Insert the new module onto the round electronic, from the User side screw in the 3 screws **T**, place the round electronic **E** into the plastic shell and secure with 3 screws **S**.

Clip-in the cable of the additional module into the retaining clamps and attach plug **P**.

### Option "Limit Switch"

Open as described before

**Sensor Part:**  
During mounting it must be observed that the set screw **Q** is screwed onto the flat part of the shaft.

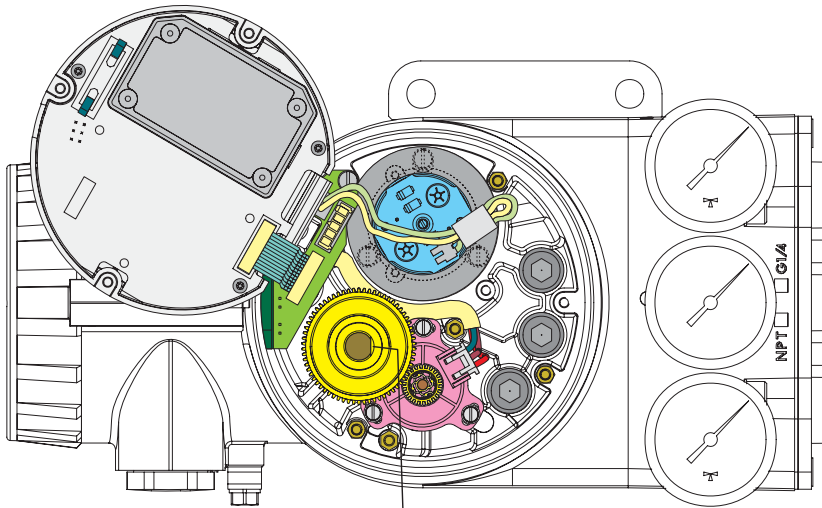

(Q)

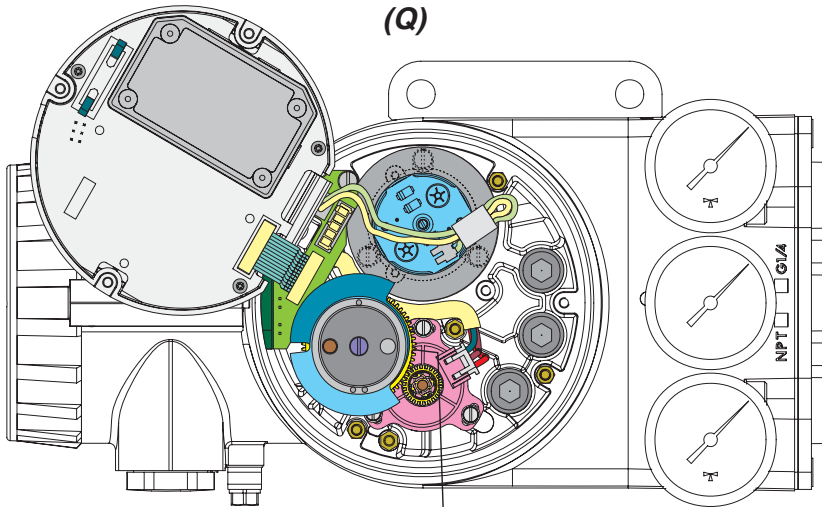

Q

Set in place the Sensor part with the switch vanes onto the steering shaft (with the big cog wheel) and secure with a sidewise set screw **Q** (Hexagon socket screw SW2).

The set screw is accessible from the right side, if the 1 marking is above (and the 2 marking is below).

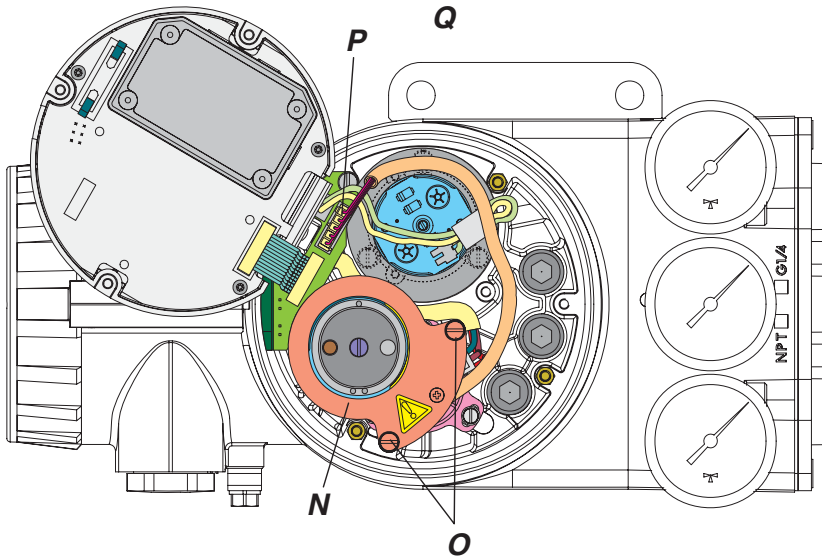

N

O

Set in place the contact assembly and the cover **N** and secure with both screws **O**.

With inductive sensors, the switching vanes must not touch the sensors. Insert the cable at plug **P**.

## 10.5 Angle calibration

When the electronic unit or the position feedback unit is replaced, the position sensor requires calibration. To accomplish the calibration, an angle calibration tool 'ACT' (WKX 425 014 038) is required.

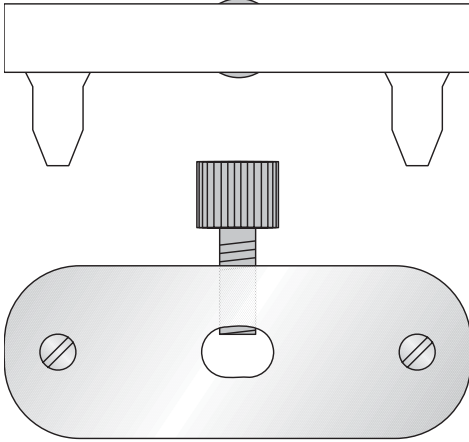

Fig.: Angle calibration tool ('ACT')

Rotate the feedback shaft **9** so that the flat side on the shaft is perpendicular to the arrow **26** on the housing. Attach the ACT to the top of the feedback shaft. Rotate the feedback shaft counter-clockwise until the two pins line up with the mounting holes **AA** on the back of the positioner, as shown below.

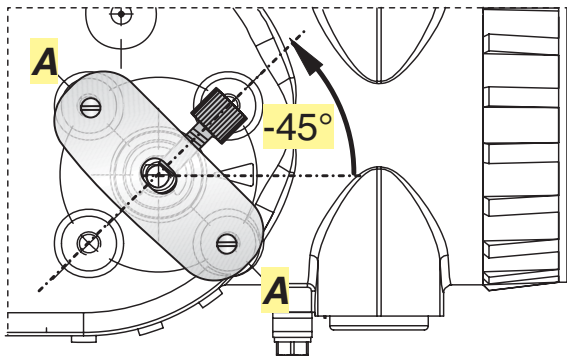

Fig.: Position "-45"

Push down the ACT until the pins are centered in the mounting holes **AA** and fasten screws to secure the ACT to the feedback shaft. The position is now locked at "-45°".

Now the measurement value of the position sensor must be stored in the SRD. This can be done locally or via software. For operation with local keys, the menu item 9.4 "Calibrate position measuring value to -45°" is used. Confirm with pressing the (✓) key. For calibration with software via PC20 / PC50 (FDT-Software) follow the directions in the appropriate workshop function. Enter value "-45" and confirm.

Now loosen the ACT and turn it with feedback shaft clockwise 90 degrees to the second set of mounting holes **BB**. See Figure.

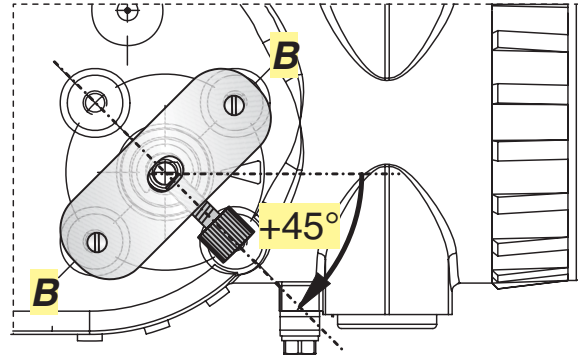

Fig.: Position "+45"

Push down the ACT until the pins are centered in the mounting holes **BB** and screws on to secure the ACT to the feedback shaft. The position is now locked at "+45°".

Now the measurement value of the position sensor must be stored in the SRD. This can be done locally or via software. For operation with local keys, the menu item 9.5 "Calibrate position measuring value to +45°" is used. Confirm with pressing the (✓) key.

For calibration with software via PC20 / PC50 (FDT-Software) follow the directions in the appropriate workshop function. Enter value "+45" and confirm.

Remove angle calibrator.

Re-connect SRD at actuator and carry out AUTOSTART, if necessary perform configuration.

## 11 TROUBLE-SHOOTING GUIDE

The components of the positioner are under constant surveillance by the installed micro controller. Errors detected are displayed in LCD or indicated by the LEDs.

Certain conditions (such as "Stroke limitation active") are displayed in LCD or indicated by the LEDs as message.

LED indication for diagnosis, errors

The following combinations are possible:

After start / reset: (X X X X = error code)

M	1	2	3	4		
-	X	X	X	X	Error detected during Init	s. 11.1

Device in normal operation:

M	1	2	3	4		
1	-	-	-	-	Cyclical self-test detects errors	s. 11.2
-	-	-	-	-	diagnosis without LED inform	s. 11.3
¼	x	x	x	x	flashing: message	s. 11.4

### 11.1 Errors detected during initialization

After start-up or reset several initialization phases are passed through which are shown in LCD or in the green LEDs. If this phase stops an error was detected.

If after renewed reset <sup>1)</sup> the indicator stops at error code the device is probably defect and should be sent to the manufacturer for repair. Stating the error code will be of help to the Repair and Service Dept.

LED Error Codes (with LCD in true text)

red M	LEDs green				Description
	1	2	3	4	
-	1	1	1	1	Micro controller functional test
-	1	1	1	-	Micro controller RAM test
-	1	1	-	1	Micro controller ROM test
-	1	1	-	-	initialize operating system
-	1	-	1	1	initialize monitor
-	1	-	1	-	initialize interfaces
-	1	-	-	1	initialize timer
-	1	-	-	-	initialize EEPROM
-	-	1	1	1	initialize data
-	-	1	1	-	initialize ADC
-	-	1	-	1	initialize communication
-	-	1	-	-	initialize local operation
-	-	-	1	1	start background process
-	-	-	1	-	check options and start
-	-	-	-	1	start operating system

1 = LED constant light

### 11.2 Errors detected during self-test

During cyclical self-test certain components of the SRD are under constant surveillance. At trouble detection in the electronics LCD or the red LED is initiated; output y1 becomes pressureless ('fail safe position').

If after reset <sup>1)</sup> the display shows the error again the device is probably defect and should be sent to manufacturer for repair.

red M	LEDs green				Description
	1	2	3	4	
1	-	-	-	-	⇒ Red LED lights up const. RAM / EPROM fault ✓ Actuate "Reset"; send device- to manufacturer if error re- appears

1 = LED constant light

1) Execute reset by simultaneous pressin (⏻) (←) (→) keys, or by turn-off and restart of input signal

### 11.3 Messages

In the SRD with option "Built-in pressure sensors" flashing is superimposed by a flickering

LEDs	Description of message / LCD text	Remedy
M 1 2 3 4 ¾ ¼ - - -	<b>Write protected</b>	
Message 1: write protection	Parameter and functions are write-protected	Can be changed via Configurator, PC20 / IFDC or PC50 (FDT)-Software or Profile 3.0 (PROFIBUS)
M 1 2 3 4 ¾ - ¼ - -	<b>Bad config CRC</b>	
Message 2: Parameter	Invalid, undefined parameter values	Reset of configuration to factory setting in Menu 9.1
M 1 2 3 4 ¾ ¼ ¼ - -	<b>Calib invalid</b>	
Message 3: Calibration	Incomplete calibration or entering value resp. calibration value outside of permissible tolerance range	Repeat calibrations in Menus 9.2 ... 9.5
M 1 2 3 4 ¾ - - ¼ -	<b>Ill loop current</b>	
Message 4: Input current outside of operating range	Check nameplate (INPUT) for correct version Message appears at : Analog or HART: input current under approx. 3.8 mA or above approx. 22 mA Fieldbus or FoxCom: input current under approx. 9 mA or above approx. 12 mA	check supply voltage (Analogue) or Bus voltage (Fieldbus), exchange SRD if necessary
M 1 2 3 4 ¾ ¼ - ¼ -	<b>Pot problem</b>	
Message 5: Position sensor	Position sensor input recognizes error	check 3-pole plug at electronic board
		check cable to sensor
		check sensor (Potentiometer: 5k +20% -0%)
	Position not within permissible rotation angle range. Lower deviation of the original 0% and exceeding of the original 100%, which have been determined by Autostart.	Check feedback lever mounting (flat area points to arrow on housing)
	During Autostart a change of the direction of movement was found	Acknowledge via key (✓), then o.k.
		Check further possible reasons: valve seat worn-out; spindle lock out-of-line; carrier unit on spindle lock is damaged (for determination of valve position).
M 1 2 3 4 ¾ - ¼ ¼ -	<b>IP motor problem</b>	
Message 6: I/P-converter output	Connection I/P converter to electronic board faulty	check 2-pole plug at electronic board check cable to the I/P converter check I/P converter to detect short circuit or interruption
M 1 2 3 4 ¾ ¼ ¼ ¼ -	<b>No supply press</b>	
Message 7: Air supply / pneumatic error	Detection: spring closes: w > 2 %, but position < 1 % spring opens: w < 98 %, but position > 99 % without spring: no actuator change in direction of position signal	check air supply pressure lead cable separated possibly poor control parameters are set pneumatic parts blocked

LEDs		Description of message / LCD text	Remedy				
M	1	2	3	4	<b>Autostart err 1</b>		
¾	-	-	-	¼	Message 8: AUTOSTART defective	Air supply too low Feedback lever (linear actuator) or Coupling (rotary actuator) incorrectly linked. Potentiometer moves out of operating range of ± 47 % of 0° position Coupling (rotary actuator) incorrectly linked (R and L interchanged) Pneumatic output to actuator closed or untight/ When direct mounting onto FlowTop or FlowPak, the screw plug y1-d is not removed. Mechanical stops not determinable When using a booster or spool valve, no control parameters can be determined, since air capacity is too high. Control parameter too high since air capacity is too high (in general, oscillation in valve movement) Possibly incomprehensible configuration data	Check air supply Check mounting. Flat area points to arrow on housing Check mounting Check pneumatic connections Check spring movement of actuator / check air supply / Check mounting Device version is not suitable for this actuator; select version with smaller air capacity or remove booster. Use a booster or the version with spool valve. Reduce control parameter prop.-gain (Menu 6.1 and 6.2) to Code 10 = value 26.6. Reset configuration, see Menu 9.1
M	1	2	3	4	<b>Autostart err 2</b>		
¾	¼	-	-	¼	Message 9: AUTOSTART defective	Configuration to single-acting instead of double-acting actuator	Initialize factory calibration for double-acting in Menu 9.7
M	1	2	3	4	<b>Optionboard err</b>		
¾	-	¼	-	¼	Message 10: Disturbances at Option board	Configured status of the SRD deviates from existing version (e.g. Option board has been inserted subsequently). Bad contact Defective	Check if correct option board has been connected Confirm message and thereby new instrument version. Connections to terminals interchanged Check connections Tighten electronics Exchange option board
M	1	2	3	4	<b>Ctrl diff error</b>		
¾	¼	¼	-	¼	Message 11: Remaining control deviation	Actuator problems (high friction or blocked) Insufficient air supply Insufficient parameters for position controls, for example, amplification too small IP module or pneumatic amplifier defect	Check actuator Check air supply / air filter Check control parameter, check pneumatic components Check in Menu 7; replace if necessary
M	1	2	3	4	<b>Lower stroke lim</b>		
¾	-	-	¼	¼	Message 12: configured closing limit has been reached	If this is desired, the message may be ignored, of course.	If not, the setting has to be checked via communication
M	1	2	3	4	<b>Upper stroke lim</b>		
¾	¼	-	¼	¼	Message 13: configured opening limit has been reached	If this is desired, the message may be ignored, of course.	If not, the setting has to be checked via communication

LEDs						Description of message / LCD text	Remedy
M	1	2	3	4			
¾	-	¼	¼	¼	Maintainance		
Message 14: Maintenance required						Operating point of controller is outside of permissible tolerance	Pneumatic components have to be checked and if necessary readjusted. Filters are possibly blocked and have to be replaced
M	1	2	3	4			
¾	¼	¼	¼	¼	Unforeseen		
Message 15:						Not defined	



**11.3 Diagnosis without LED or LCD inform**

Fault	Possible cause	Solution
Positioner not operational using key pads	No input signal at 11, 12	Connect input signal
	Local operation blocked (write protection)	Remove blockage via communication
	No automatic power up (Reset)	Reset SRD with keys
	A key got jammed	Release cover screws, check menu functions, retighten cover
	Failure in the positioner	send device to manufacturer
Autostart not completed (> 45 min)	Actuator volume too large	stop Autostart and carry out extended Autostart, see chapter 8.3, Menü 2 or apply booster
	Failure in the positioner, otherwise Message 8, 9	carry out Autostart again, see chapter. 8.1 and 8.3, Menu 2 carry out Reset configuration send device to manufacturer
	Autostart remains stagnant for a longer time (>10 min) in step 1 or 2 (LED 1 or 2 lights up), otherwise message 8	Feedback lever (at stroke actuator) incorrectly mounted. Verify installation of feedback lever, see chapt. 4; flat part points to arrow on housing
		Coupling piece (at rotary actuator) incorrectly turned (R and L mixed up): Verify direction of rotation, see chapt. 4; flat part points to arrow on housing
	Autostart remains stagnant for a longer time (>10 min) in step 3 (LCD: shows "Control params") (LED: #3 lights up)	At large volume actuators the Autostart can possibly remain stagnant for a longer time (>10 min) in step 3, prior to continuing in step 4
Actuator does not react to a change in the input signal	No Autostart performed.	Perform Autostart.
	Positioner is not IN OPERATION	Switch positioner IN OPERATION, see chap. 8.2 resp. Autostart or via Configurator
	Setpoint source is configured wrong	Correct configuration via configurator
Actuator does not attain the closed or opened position	Autostart not carried out	carry out Autostart
	Supply pressure too low	check supply air pressure
	Travel limit is set Message 12, 13	check settings, see chapter 8.3, Menu 5
	Angle position linearization, positioner action or characteristic curve is set incorrectly (e.g. 'Custom', but values are missing)	check settings, see chapter 8.3, Menus 1, 3, 4
Unstable behaviour, position control circuit oscillates	Autostart incomplete, therefore, control parameters not suitable	carry out complete Autostart, see chapter 8.3, Menu 2
	Small actuator volume but high air capacity	increase damping at pneumatic output, see chapter 8.3, Menu 8
	Friction on valve packing too great	loosen packing gland slightly or replace
	IP module or Pneumatic amplifier defective	change module, see page 47
Actuator reacts too sluggish	air capacity insufficient	attach booster
	damping set too high	reduce damping at pneumatic output, see chapter 8.3, Menu 8
	positioning time T63 set too high	reduce positioning time, see chapter 8.3, Menu 6
No communication possible	Input voltage too low	Eliminate voltage drop
	Faulty protocol, communicator and device type do not match	Check configuration of devices
	Wrong electronics unit	change device

For tuning controller parameters see remarks on page 38.

## 12 SAFETY REQUIREMENTS

### 12.1 EMC and CE

For notes regarding Electromagnetic compatibility EMC and CE labels see Product Specifications Sheet PSS EVE0109 A.

In order to ensure EMC protection, the screwed electronics housing must be locked.

### 12.2 Explosion protection

(Only if ordered)

Technical data for explosion protection see Product Specifications Sheet PSS EVE0109 A or Certificates of Conformity EX EVE0109 A.

For installations located in explosive atmospheres, all relevant national regulations and installation conditions must be observed, e.g. in the Federal Republic of Germany ExV and DIN VDE 0165.

#### Attention:

When repairing explosion-protected equipment, observe the national regulations.

Repairs involving parts must be manufacturer's original parts.

The following applies to the Federal Republic of Germany: Repairs involving parts required for explosion protection must either be carried out by the manufacturer or by authorized personnel and confirmed by certificate.

## 13 SYSTEM CONFIGURATION

The safety requirements must be observed!

### 13.1 HART Communication

When using the 'communication' (an alternating current signal, which is modulated onto the 4-20 mA signal), it must be observed that the connected outputs are suitable for the used frequency ranges. Apart from the load, also the alternating current impedances have to be observed. It is recommended therefore, to use only suitable instruments.

To eliminate crosstalk between leads and to reduce disturbances through electromagnetic influences, it is recommended to use twisted paired shielded leads (0,3...2,5 mm<sup>2</sup>, max. 100 pF/m).

The capacities of the leads and the connected instruments must not exceed the maximum values for HART.

All components which are connected to the SRD in an explosion hazardous area, require an Ex-Approval. The therein applicable limit values must not be exceeded in any case. These limit values also have to be adhered to when connecting additional capacitances, inductances, voltages and currents.

#### Measuring HART Communication Signal

If a reliable communication signal can not be received, it is advisable to check the level with an oscilloscope. The first data block always comes from the configurator and the second block is the reply from the SRD.

HART	measured at configurator:	measured at SRD:
Configurator transmits	at least 350 mVpp	at least 120 mVpp
SRD960 transmits	at least 120 mVpp	at least 400 mVpp

### 13.2 FoxCom Communication

When using the 'communication' (a rectangular signal which is modulated onto the constant current signal), it must be observed that the connected outputs are suitable for the used frequency ranges. The supply instrument must be a voltage source with an impedance of 250 ... 500 Ohm. The total of all instrument and lead capacities must be <60 nF. It is recommended therefore, to use only suitable instruments.

To eliminate crosstalk between leads and to reduce disturbances through electromagnetic influences, it is recommended to use twisted paired shielded leads (0,3...2,5 mm<sup>2</sup>, max. 100 pF/m).

The capacities of the leads and the connected instruments must not exceed the maximum values for FoxCom.

All components which are connected to the SRD in an explosion hazardous area, require an Ex-Approval. The therein applicable limit values must not be exceeded in any case. These limit values also have to be adhered to when connecting additional capacitances, inductances, voltages and currents.

#### Measuring FoxCom Communication Signal

If a reliable communication signal can not be received, it is advisable to check the level with an oscilloscope. The first data block always comes from the configurator and the second block is the reply from the SRD.

FOXCOM	measured at configurator:	measured at SRD:
Configurator transmits (Request)	at least 350 mVpp	at least 75 mVpp
SRD transmits (Acknowledge)	at least 75 mVpp	at least 350 mVpp

### 13.3 With Communication PROFIBUS-PA

The operation of the positioner takes place digital, as per PROFIBUS-PA Profile Class B acc. to EN 50170 and DIN 19245 part 4. Data transmission via bit synchronous current modulation with a speed of 31250 bits via twisted and shielded two-wire connections acc. to IEC 1158-2, with cable shields on both sides and bus terminators according to recommendation IEC 1158-2.

The positioner has to be connected to a segment coupler, which has to be conforming to IEC 1158-2. For operation in explosion hazardous areas, a segment coupler in explosion proof version has to be used. Supply as well as communication takes place via the bus.

All components which are connected to the SRD in an explosion hazardous area, require an Ex-Approval. The therein applicable limit values must not be exceeded in any event. These limit values also have to be adhered to when connecting additional capacitances, inductances, voltages and currents. The FISCO model is thereby used as a basis.

Further information for observance:  
"Technical Guide for PROFIBUS-Connection Technique"  
PROFIBUS-User Organisation, Order no. 2.141

### 13.4 With Communication FOUNDATION Fieldbus

The operation of the positioner takes place digital, as per FOUNDATION Fieldbus Specification Rev. 1.4. Data transmission via bit synchronous current modulation with a speed of 31250 bits of via twisted and shielded two-wire connections acc. to IEC 1158-2, with cable shields on both sides and bus terminators according to recommendation IEC 1158-2.

The positioner has to be connected to components which are conforming to IEC 1158-2. For operation in explosion hazardous areas, an Ex-separator has to be used. Supply as well as communication takes place via the bus.

All components which are connected to the SRD in an explosion hazardous area, require an Ex-Approval. The therein applicable limit values must not be exceeded in any event. These limit values also have to be adhered to when connecting additional capacitances, inductances, voltages and currents. The FISCO model is thereby used as a basis.

Further information for observance:  
"Wiring and Installation 31.25 kBit/s, Voltage Mode, Wire Medium Application Guide" by FOUNDATION fieldbus

## 13.5 System configuration

### Electrical classification

#### Type of protection ATEX „EEx d – Flameproof“

II 2 G EEx d IIC Temperature classes T4...T6

(Design AD 639)

EC Approval document No. PTB 02 ATEX 1084 X

Ambient temperature ranges:

Temperature class T4      –30 °C... +80 °C  
  (–22 °F ... 176 °F)

Temperature class T4 (on request)   –40 °C ... +80 °C  
  (–40 °F ... 176 °F)

Temperature class T6      –30 °C... +75 °C  
  (–22 °F ... 167 °F)

Temperature class T6 (on request)   –40 °C ... +75 °C  
  (–40 °F ... 167 °F)

#### Type of protection FM “explosion proof”

Class I Division 1, Groups B, C, D

hazardous locations, indoor and outdoor, NEMA 4X

For connections in explosion protected hazardous areas according to directive 94/9/EG appendix II, with the following maximum values.

### Electrical connection

Connection compartment see page 23

#### Electrical connection for SRD960 in non intrinsic safe and flameproof (EEx d) version

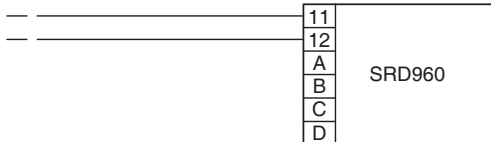

### Terminals:

	Input		Options			
	11	12	A	B	C	D
Input signal / Setpoint value						
HART/FoxCom/ 4-20mA	11+	12–				
Fieldbus acc. to IEC 1158-2	11**	12**				
Options / Additional In-/Outputs						
Position feedback			81+	82–	31+	32–
Binary output			81+	82–	83+	84–
Binary input			13+	14–	15+	16–
Limit signal switch			41+	42–	51+	52–
Potentiometer						
Sensor						

### Connection values

#### HART / 4-20 mA

Terminals                           11+ / 12–  
Signal range                       4 ... 20 mA  
Input voltage                       DC 12 ... 36 V (non loaded)

#### FOUNDATION Fieldbus

Terminals                           11 / 12\*\*  
Bus connection                   Fieldbus interface acc. to IEC 1158-2  
Supply voltage                   DC 9 ... 32 V <sup>2)</sup>  
max. Supply voltage           DC 36V  
Operating current               10.5 mA ± 0.5 mA

#### PROFIBUS-PA

Terminals                           11 / 12\*\*  
Bus connection                   Fieldbus interface acc. to IEC 1158-2  
Supply voltage                   DC 9 ... 32 V <sup>2)</sup>  
max. Supply voltage           DC 36V  
Operating current               10.5 mA ± 0.5 mA

#### FoxCom

Terminals                           11+ / 12–  
Supply voltage                   DC 13 ... 36 V <sup>2)</sup>  
max. Supply voltage           DC 36V  
Operating current               ~ 9 mA bei DC 24 V

\*\* any Polarity

2) When in use in Ex-hazardous areas, the max. supply voltages, etc. on nameplate resp. certificate of conformity, have to be observed!

**Connection values “Additional In-/Outputs”****Position feedback 4 to 20 mA**

Terminals for AI1: 31+ / 32-  
 supply voltage: DC 8 ... 36 V  
 signal range 3.8 ... 21.5 mA

0 % and 100 % configurable

device fault < 1 mA

Terminals for AB1: 81+ / 82-

1 Binary output alarm, galvanically separated, two-wire system, according to DIN 19234, for external supply

supply voltage DC 8 ... 36 V

Logic: no alarm < 1 mA  
 alarm > 2.2 mA  
 device fault < 50 µA

**Binary Input**

Terminals for EB1: 13+ / 14-

Terminals for EB2: 15+ / 16-

A connected switch is loaded with 3 V, 150 µA.

Switch 1	Switch 2	Actuator control function
close	close	normal operation
open	close	go to stop at 0 %
close	open	go to stop at 100 %
open	open	hold last position

Requirements for connected switches:

Capacitance in parallel < 100 nF  
 Resistivity for ON < 2 kOhm  
 Resistivity for OFF > 10 kOhm  
 Hysteresis 2 ... 5 kOhm

**Binary outputs**

Terminals for AB1: 81+ / 82-

Terminals for AB2: 83+ / 84-

two-wire system, according to DIN 19234, for external supply

supply voltage DC 8 ... 36 V

Logic:  
 limit value not exceeded < 1 mA  
 limit value exceeded > 2.2 mA (typ. 6 mA)  
 device fault < 50 µA

configurable as switch output:

limit value not exceeded < 50 µA  
 limit value exceeded > 20 mA / 20 V  
 > 40 mA / 10 V

**Potentiometer** (in preparation)

**Sensor** (in preparation)

**Built-in Limit Switch**

Terminals for GW1: 41+ / 42-

Terminals for GW2: 51+ / 52-

in two-wire-technique acc. to DIN 19234 with external power supply for connection to switching amplifier, or in three-wire-technique

Current consumption

vane clear > 2.2 mA  
 vane interposed < 1 mA

for control circuit with the following electrical values

supply voltage DC 8 V, Ri ca. 1 kOhm  
 supply voltage range DC 5...25 V  
 residual ripple < 10 % p.p.  
 permissible line resistance < 100 Ohm

Response characteristic <sup>1) 2)</sup>

switching differential 1 %  
 switching point repeatability 0.2 %

**Non intrinsic safe and EEx d - Input circuit**

Max. electrical Power Pmax = 2,5 W

Terminals and cable glands Umax = 60 V

Self-heating-up of housing surface 1.3 K/W

**Additional In-/Outputs EEx d** (will follow)

**EEx i - Input circuit**

Input circuit max. values

HART / FoxCom / 4-20 mA:

Ui= 30 V, li= 130 mA, Pi= 0.9 W, Ci= 1.3 nF, Li= 5 µH

FOUNDATION Fieldbus / PROFIBUS:

Ui= 24 V, li= 380 mA, Pi= 5.2 W, Ci= 1.3 nF, Li= 5 µH

**Additional In-/Outputs EEx i**

Option:

**Position feedback**

Ui= 16 V, li= 80 mA, Pi= 250 mW, Ci= 26 nF, Li= 5 µH

**Binary Input**

Uo= 7.88 V, Io= 11.4 mA, Po= 23 mW

IIC		IIB	
Lo [mH]	Co [µF]	Lo [mH]	Co [µF]
100	0.72	100	3.9
10	1.1	10	5.5
1	1.6	1	8.7
0.1	2.7	0.1	15
0.01	4.7	0.01	27

(Li and Ci integrated)

**Binary Output**

Ui= 16 V, li= 80 mA, Pi= 250 mW, Ci= 26 nF, Li= 5 µH

**Potentiometer**

(will follow)

**Sensor**

(will follow)

**Limit switches**

Ui= 16 V, li= 25 mA, Pi= 64 mW, Ci= 30 nF, Li= 100 µH

1) Data measured according to VDI/VDE 2177

2) With stroke 30 mm and lever length 90 mm

DIMENSIONS

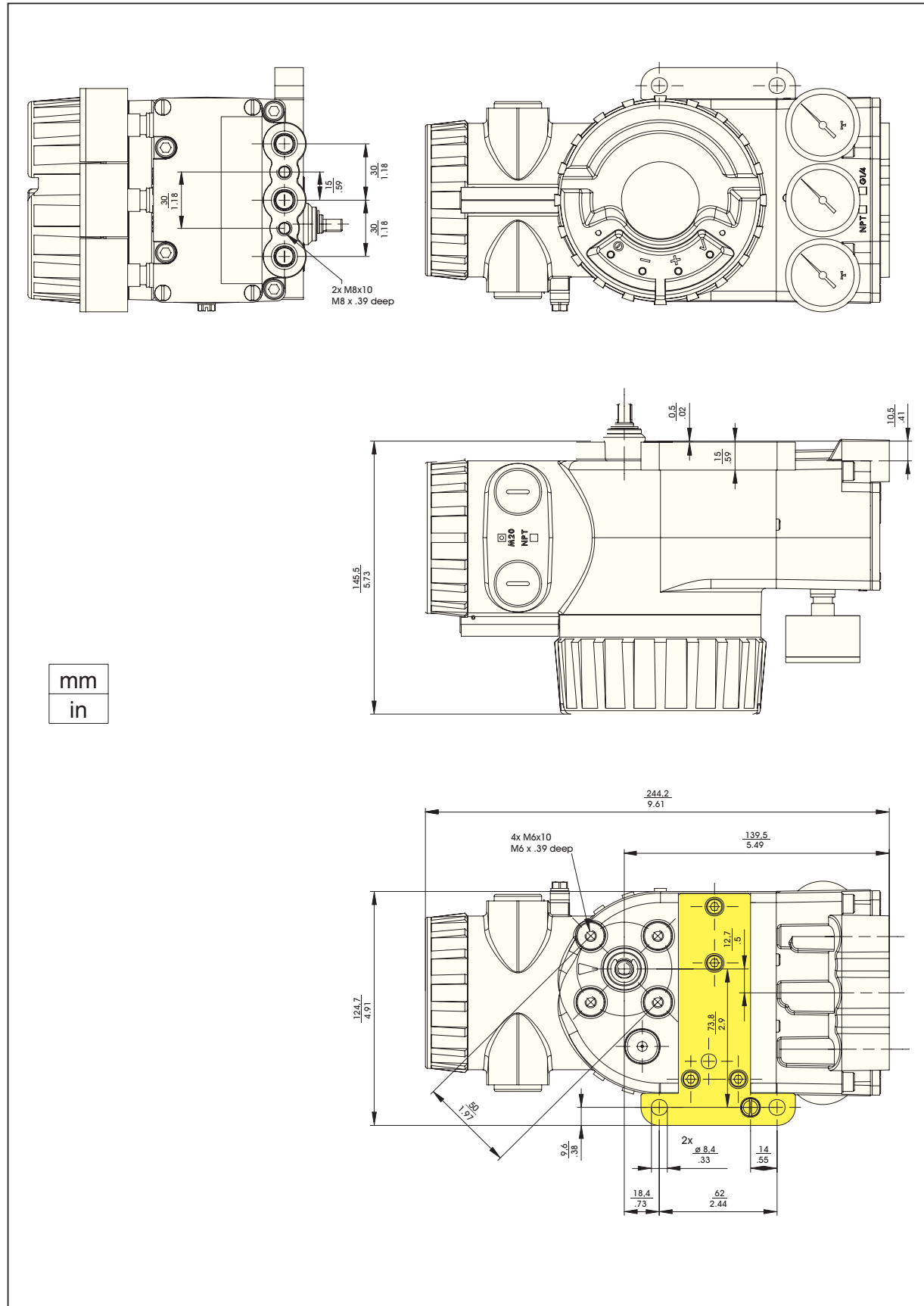

**Additional Documentation for this product:****Technical Information of Attachment Kits for Positioners**

TI EVE0011 A Overview of Attachment Kits of all positioners on actuators/valves of different manufacturers

**Quick Guide**

QG EVE0109 A Extract of Master Instruction for an easy to use, easy understandable and fast start-up.  
This document highlights the most important.

**Master Instructions:**

MI EVE0109 A SRD960 -All Versions -

**Technical Information for Fieldbus-Communication:**

TI EVE0109 P SRD991/960 -PROFIBUS-PA

TI EVE0109 Q SRD991/960 -FOUNDATION Fieldbus H1

**Master Instruction for HART-Communication:**

MI EVE0109 B HART with Hand-Held Terminal

**Master Instruction for configuration- and operation-software PC20 and integration into Foxboro I/A Series System:**

MI 020-495 HART / FoxCom / PROFIBUS-PA and IRCOM with PC by means of PC20/ IFDC  
B 0193 VH I/A Series System

**Additional Documentation for other products:****Product Specifications**

PSS EVE0105 A	SRD991 Intelligent Positioner
PSS EVE0106 A	SRD992 Digital Positioner
PSS EVE0109 A	SRD960 Universal Positioner
PSS EVE0107 A	SRI990 Analog Positioner
PSS EVE0102 A	SRI986 Electro-Pneumatic Positioner
PSS EVE0103 A	SRI983 Electro-Pneumatic Positioner- explosion proof or EEx d version
PSS EVE0101 A	SRP981 Pneumatic Positioner
PSS EMO0100 A	Accessories for devices with HART Protocol

Subject to alterations - reprinting, copying and translation prohibited. Products and publications are normally quoted here without reference to existing patents, registered utility models or trademarks. The lack of any such reference does not justify the assumption that a product or symbol is free.

FOXBORO ECKARDT GmbH  
Postfach 50 03 47  
D-70333 Stuttgart  
Tel. # 49(0)711 502-0  
Fax # 49(0)711 502-597  
<http://www.foxboro-eckardt.com>

DOKT 533 495 144

