

LR01 Free-Space Radar Level Meter



The LevelWave LR01 is designed to perform continuous level measurement in a wide range of industries and applications. Foxboro Eckardt is known for more than 50 years of experience in level measurement as a leading supplier of extremely robust, durable and reliable level measurements. Unaffected by changes in temperature, specific gravity, pressure and with no need to recalibrate, offering a highly available measurement at low maintenance cost. With the LevelWave LR01 you achieve a highly modular system which is designed for the requirements of the modern industry.

FEATURES

- 2-wire Loop powered 10 GHz FMCW technology
- Wave Horn Antenna in PP or PTFE for corrosive media
- 360° rotatable housing with snap solution
- Housing and cover with bayonet connectors
- Horizontal or vertical housing position
- Remote electronics (up to 100 m / 328 ft)
- Weather protection cap
- Measuring range up to 30 m / 98.4 ft
- Empty Tank Spectrum (ETS) function
- HART Communication, 4 to 20 mA
- Configuration via FDT-DTM
- Continuous self-diagnostics, Status and diagnostic messages, acc. to NE 107
- Process temperature from -60 to +250 °C
- Process pressure from -1 to 40 bar
- SIL2-compliant acc. to IEC 61508 for safety related systems
- Local multilingual full graphic LCD, configurable in %, mA or physical units
- Display with external keypad

Contents

1	Safety instructions	6
<hr/>		
1.1	Software history	6
1.2	Intended use	6
1.3	Certification	7
1.4	Radio approvals	8
1.4.1	European Union (EU)	8
1.4.2	U.S.A. and Canada	9
1.5	Safety instructions from the manufacturer	10
1.5.1	Copyright and data protection	10
1.5.2	Disclaimer	10
1.5.3	Product liability and warranty	11
1.5.4	Information concerning the documentation	11
1.5.5	Warnings and symbols used	12
1.6	Safety instructions for the operator	12
2	Device description	13
<hr/>		
2.1	Scope of delivery	13
2.2	Device description	14
2.3	Visual Check	16
2.4	Nameplates	17
2.4.1	Nameplate (examples)	17
3	Installation	18
<hr/>		
3.1	General notes on installation	18
3.2	Storage	18
3.3	Transport	19
3.4	Pre-installation requirements	19
3.5	Installation	20
3.5.1	Pressure and temperature ranges	20
3.5.2	Recommended mounting position	22
3.5.3	Mounting restrictions	24
3.5.4	Standpipes (stilling wells and bypass chambers)	29
3.5.5	Wall support for the remote version	32
3.5.6	How to attach an antenna extension (Metallic Horn or Wave Guide antennas)	33
3.5.7	How to turn or remove the signal converter	35
3.5.8	How to attach the weather protection to the device	36
3.5.9	How to open the weather protection	39
4	Electrical connections	40
<hr/>		
4.1	Safety instructions	40
4.2	Electrical installation: 2-wire, loop-powered	40
4.2.1	Compact version	40
4.2.2	Remote version	42
4.3	Remote device data	43
4.3.1	Requirements for signal cables supplied by the customer	43
4.3.2	How to prepare a signal cable supplied by the customer	44
4.3.3	How to connect the signal cable to the device	45

4.4	Electrical connection for current output	49
4.4.1	Non-Ex devices	49
4.4.2	Devices for hazardous locations	49
4.5	Protection category	49
4.6	Networks	50
4.6.1	General information	50
4.6.2	Point-to-point connection	50
4.6.3	Multi-drop networks	51
4.6.4	Fieldbus networks	52
5	Start-up	54
5.1	How to start the device	54
5.1.1	Start-up checklist	54
5.1.2	How to start the device	54
5.2	Operating concept	54
5.3	Digital display screen	55
5.3.1	Local display screen layout	55
5.3.2	Functions of keypad buttons	56
5.4	Remote communication with PACTware™	56
5.5	Remote communication with the AMS™ Device Manager	57
6	Operation	58
6.1	User modes	58
6.2	Normal mode	58
6.3	Configuration mode	60
6.3.1	General notes	60
6.3.2	How to get access to the commissioning menu	60
6.3.3	Keypad functions	61
6.3.4	Menu overview	64
6.3.5	Function description	65
6.4	Further information on device configuration	72
6.4.1	Quick Setup (Parameters)	72
6.4.2	Test	74
6.4.3	Protection of the device settings	75
6.4.4	HART® network configuration	75
6.4.5	Distance measurement	76
6.4.6	Level measurement	77
6.4.7	How to configure the device to measure volume or mass	78
6.4.8	How to make a filter to remove radar signal interference	79
6.5	Status and error messages	81
6.5.1	Device status (markers)	81
6.5.2	Error handling	83
7	Service	87
7.1	Periodic maintenance	87
7.2	How to clean horn antennas under process conditions	87
7.3	Heating or cooling horn antennas under process conditions	88
7.4	How to replace device components	88
7.4.1	Service warranty	88
7.5	Spare parts availability	89
7.6	Availability of services	89

7.7 Returning the device to the manufacturer.....	89
7.7.1 General information	89
7.7.2 Form (for copying) to accompany a returned device	90
7.8 Disposal.....	90
8 Technical data	91
<hr/>	
8.1 Measuring principle.....	91
8.2 Technical data	93
8.3 Minimum power supply voltage	100
8.4 Pressure ratings.....	101
8.5 Antenna selection	107
8.6 Dimensions and weights.....	108
9 Description of HART interface	115
<hr/>	
9.1 General description.....	115
9.2 Software description	115
9.3 Connection variants	116
9.3.1 Point-to-Point connection - analogue / digital mode	116
9.3.2 Multi-Drop connection (2-wire connection)	116
9.4 HART [®] device variables	116
9.5 Field Communicator 375/475 (FC 375/475)	117
9.5.1 Installation.....	117
9.5.2 Operation	117
9.6 Asset Management Solutions (AMS).....	118
9.6.1 Installation.....	118
9.6.2 Operation	118
9.6.3 Parameter for the basic configuration	118
9.7 Field Device Tool / Device Type Manager (FDT / DTM).....	118
9.7.1 Installation.....	118
9.7.2 Operation	118
9.8 Process Device Manager (PDM)	119
9.8.1 Installation.....	119
9.8.2 Operation	119
9.9 HART [®] menu tree for Basic-DD	120
9.9.1 Overview Basic-DD menu tree (positions in menu tree).....	120
9.9.2 Basic-DD menu tree (details for settings)	121
9.10 HART [®] menu tree for AMS.....	122
9.10.1 Overview AMS menu tree (positions in menu tree)	122
9.10.2 AMS menu tree (details for settings)	123
9.11 HART [®] menu tree for PDM	124
9.11.1 Overview PDM menu tree (positions in menu tree)	124
9.11.2 PDM menu tree (details for settings)	125
10 Appendix	127
<hr/>	
10.1 Glossary.....	127

1 Safety instructions

1.1 Software history

"Firmware revision" agrees with NAMUR NE 53. It is a series of numbers used to record the revision status of embedded software (firmware) in electronic equipment assemblies. It gives data on the type of changes made and the effect that changes have on compatibility.

Data about software revisions is shown in menu 1.1.0 IDENT. For more data, refer to *Function description* on page 65. If it is not possible to refer to the device menu, record the serial number of the device (given on the device nameplate) and speak to the supplier.

Release date	Printed circuit assembly	Firmware revision	Hardware revision	Changes and compatibility	Documentation
2013-01-11	Converter	1.00.05	4000342401k	-	HB LR01 Rev. 06.2013
	Sensor	1.00.06	4001025501h		
	HMI (LCD display option)	1.00.03	4000487601n		

1.2 Intended use



CAUTION!

Responsibility for the use of the measuring devices with regard to suitability, intended use and corrosion resistance of the used materials against the measured fluid lies solely with the operator.



INFORMATION!

The manufacturer is not liable for any damage resulting from improper use or use for other than the intended purpose.

This level meter with Radar (FMCW) measures distance, level, mass, volume, flow rate (in open channels) and reflectivity of liquids, pastes and slurries. It does not touch the measured product.

1.3 Certification



DANGER!

For devices used in hazardous areas, additional safety notes apply; please refer to the Ex documentation.



In accordance with the commitment to customer service and safety, the device described in this document meets the following safety requirements:

- Electromagnetic Compatibility (EMC) Directive 2004/108/EC in conjunction with EN 61326-1 (2006). SIL-approved devices agree with EN 61326-3-1 (2008) and EN 61326-3-2 (2008).
- Radio Equipment and Telecommunications Terminal Equipment (R & TTE) Directive 1999/05/EC in conjunction with ETSI EN 302 372 (2006). For more data, refer to *European Union (EU)* on page 8.
- Low-Voltage Directive 2006/95/EC in conjunction with EN 61010-1 (2001).
- SIL-approved devices agree with EN 61508 (2010).

All devices are based on the CE marking and meet the requirements of NAMUR Guideline NE 21, NE 43, NE 53 and NE 107.

1.4 Radio approvals

1.4.1 European Union (EU)



LEGAL NOTICE!

This level transmitter is intended for installation in closed tanks. It meets the requirements of the R & TTE (Radio Equipment and Telecommunications Terminal Equipment) Directive 1999/05/EC for use in the member countries of the EU.

An industry agreement includes approval for use of the frequency band (8.6...10.4 GHz) in industrial environments.

According to article 6.4 of the R&TTE Directive, the product is marked by the CE sign + notified body number (0682) + Class II identifier (= alert sign).

Refer to EN 302372 for installation conditions.

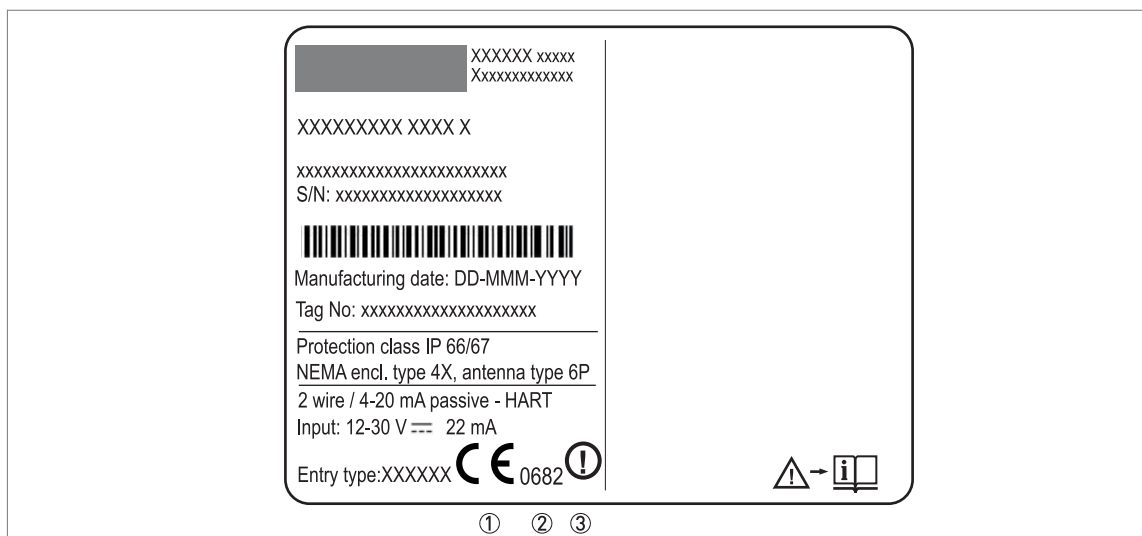

Figure 1-1: Radio approval information on the nameplate

- ① CE sign
- ② Notified body number (0682 = CETECOM ICT Services GmbH)
- ③ Class II identifier

According to ETSI EN 302 372 (2006-04), the radiated power outside a metallic tank is less than -30 dBm.

The device and the tank agree with Annex B of ETSI EN 302 372-1 if you obey the regulations that follow:

- Install the device in a permanent position on a closed metallic tank, a reinforced concrete tank or a structure with a closed space made of an equivalent material. Make sure that the device is correctly attached. We recommend that you install the device on the top of the tank and the antenna points down.
- Seal flanges and attachments with EMI/RFI shielding gaskets. This gasket is supplied as an accessory.
- Sight glasses must have a microwave-proof layer on them.
- Close all openings and process connections.
- Only approved personnel can install the device.

For data about how to install EMI/RFI shielding gaskets, refer to the instructions supplied with this accessory.

Refer also to the radio approval certificate on the internet site.

1.4.2 U.S.A. and Canada



LEGAL NOTICE!

This device complies with Part 15 of the FCC Rules and with RSS-210 of Industry Canada.

Operation is subject to the following two conditions:

- 1. This device may not cause harmful interference, and*
- 2. This device must accept any interference received, including interference which may cause undesired operation.*

Changes or modifications made to this equipment not expressly approved by the manufacturer may void the FCC and IC authorizations to operate this equipment.

This legal information is shown on a label on the side of the device.

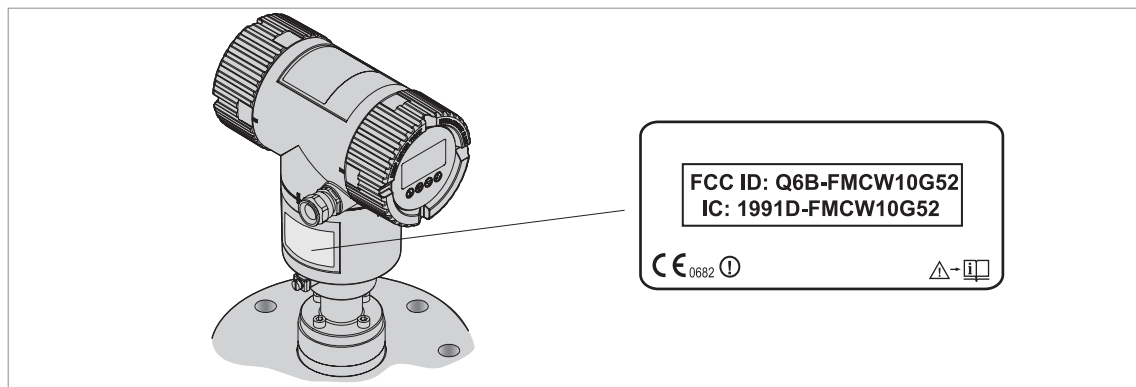

Figure 1-2: FCC ID and IC number label

Refer also to the radio approval certificate on the internet site.

1.5 Safety instructions from the manufacturer

1.5.1 Copyright and data protection

The contents of this document have been created with great care. Nevertheless, we provide no guarantee that the contents are correct, complete or up-to-date.

The contents and works in this document are subject to copyright. Contributions from third parties are identified as such. Reproduction, processing, dissemination and any type of use beyond what is permitted under copyright requires written authorisation from the respective author and/or the manufacturer.

The manufacturer tries always to observe the copyrights of others, and to draw on works created in-house or works in the public domain.

The collection of personal data (such as names, street addresses or e-mail addresses) in the manufacturer's documents is always on a voluntary basis whenever possible. Whenever feasible, it is always possible to make use of the offerings and services without providing any personal data.

We draw your attention to the fact that data transmission over the Internet (e.g. when communicating by e-mail) may involve gaps in security. It is not possible to protect such data completely against access by third parties.

We hereby expressly prohibit the use of the contact data published as part of our duty to publish an imprint for the purpose of sending us any advertising or informational materials that we have not expressly requested.

1.5.2 Disclaimer

The manufacturer will not be liable for any damage of any kind by using its product, including, but not limited to direct, indirect or incidental and consequential damages.

This disclaimer does not apply in case the manufacturer has acted on purpose or with gross negligence. In the event any applicable law does not allow such limitations on implied warranties or the exclusion of limitation of certain damages, you may, if such law applies to you, not be subject to some or all of the above disclaimer, exclusions or limitations.

Any product purchased from the manufacturer is warranted in accordance with the relevant product documentation and our Terms and Conditions of Sale.

The manufacturer reserves the right to alter the content of its documents, including this disclaimer in any way, at any time, for any reason, without prior notification, and will not be liable in any way for possible consequences of such changes.

1.5.3 Product liability and warranty

The operator shall bear responsibility for the suitability of the device for the specific purpose. The manufacturer accepts no liability for the consequences of misuse by the operator. Improper installation and operation of the devices (systems) will cause the warranty to be void. The respective "Standard Terms and Conditions" which form the basis for the sales contract shall also apply.

1.5.4 Information concerning the documentation

To prevent any injury to the user or damage to the device it is essential that you read the information in this document and observe applicable national standards, safety requirements and accident prevention regulations.

If this document is not in your native language and if you have any problems understanding the text, we advise you to contact your local office for assistance. The manufacturer can not accept responsibility for any damage or injury caused by misunderstanding of the information in this document.

This document is provided to help you establish operating conditions, which will permit safe and efficient use of this device. Special considerations and precautions are also described in the document, which appear in the form of underneath icons.

1.5.5 Warnings and symbols used

Safety warnings are indicated by the following symbols.



DANGER!

This information refers to the immediate danger when working with electricity.



DANGER!

This warning refers to the immediate danger of burns caused by heat or hot surfaces.



DANGER!

This warning refers to the immediate danger when using this device in a hazardous atmosphere.



DANGER!

These warnings must be observed without fail. Even partial disregard of this warning can lead to serious health problems and even death. There is also the risk of seriously damaging the device or parts of the operator's plant.



WARNING!

Disregarding this safety warning, even if only in part, poses the risk of serious health problems. There is also the risk of damaging the device or parts of the operator's plant.



CAUTION!

Disregarding these instructions can result in damage to the device or to parts of the operator's plant.



INFORMATION!

These instructions contain important information for the handling of the device.



LEGAL NOTICE!

This note contains information on statutory directives and standards.



• **HANDLING**

This symbol designates all instructions for actions to be carried out by the operator in the specified sequence.

➔ **RESULT**

This symbol refers to all important consequences of the previous actions.

1.6 Safety instructions for the operator



WARNING!

In general, devices from the manufacturer may only be installed, commissioned, operated and maintained by properly trained and authorized personnel.

This document is provided to help you establish operating conditions, which will permit safe and efficient use of this device.

2 Device description

2.1 Scope of delivery

**INFORMATION!**

Do a check of the packing list to make sure that you have all the elements given in the order.

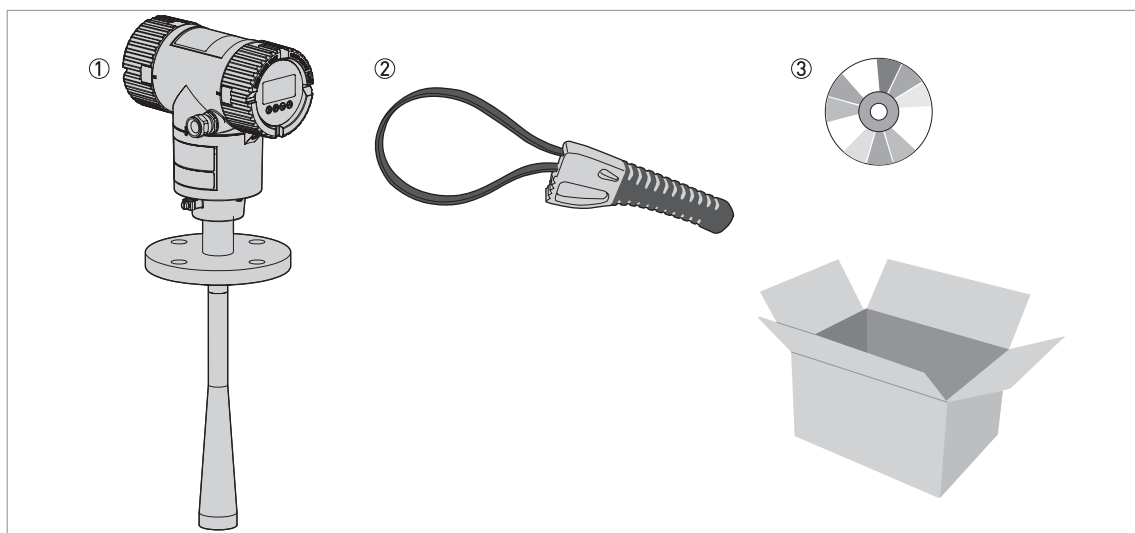

Figure 2-1: Scope of delivery

- ① Signal converter and antenna (compact version)
- ② Strap wrench
- ③ DVD-ROM (including Handbook, Quick Start, Technical Datasheet and related software)

**INFORMATION!****METALLIC HORN AND WAVE GUIDE ANTENNAS**

If the device has an antenna extension option, this part is attached to the device if the antenna extension length, $L_{ext} \leq 300 \text{ mm} / 11.8''$. If $L_{ext} > 300 \text{ mm} / 11.8''$, then the antenna extension is not attached to the device. Obey the assembly procedure on page 33.

2.2 Device description

The FMCW radar level transmitter is designed to measure the distance, level, mass, volume, flow rate and reflection of liquids, pastes and slurries. Radar level transmitters use an antenna to guide a signal to the surface of the measured product. Radar is a non-contact technology. It is particularly suitable for the level measurement of corrosive and viscous products. For more data about the measuring principle, refer to *Measuring principle* on page 91.

The signal converter of the device has 2 versions: Compact and Remote (Field). The converter can also be ordered with horizontal or vertical housing options for easy access to the device terminals and the optional display.

Compact version

The signal converter is attached directly to the process connection and the antenna (vertical housing option shown).

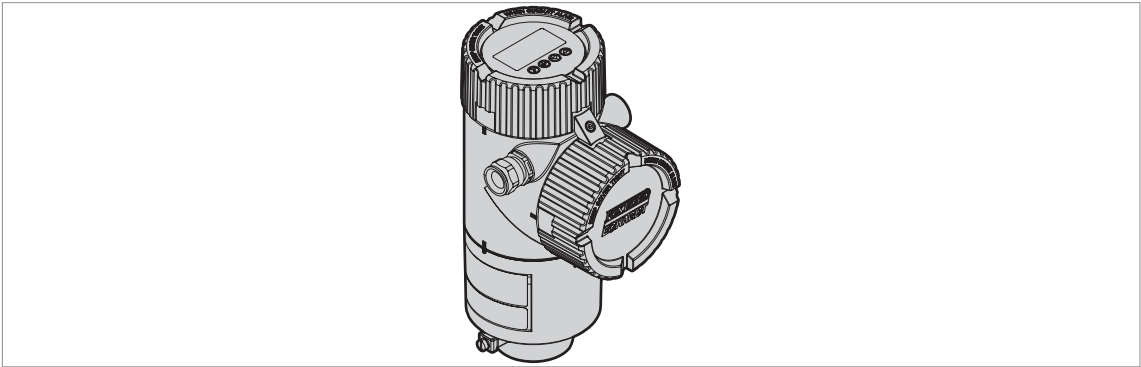

Figure 2-2: Compact version

Remote (Field) version

The signal converter is installed away from the process connection and the antenna (for example: at the bottom of a tank). The signal cable between the signal converter and the antenna has a maximum length of 100 m / 328 ft.

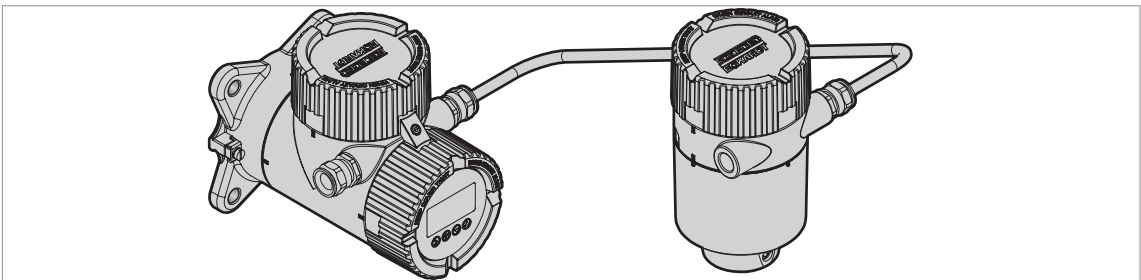

Figure 2-3: Remote version

The illustration that follows shows the types of antenna. Antenna extensions are available for PTFE Wave Horn and Metallic Horn antenna options for long nozzles.

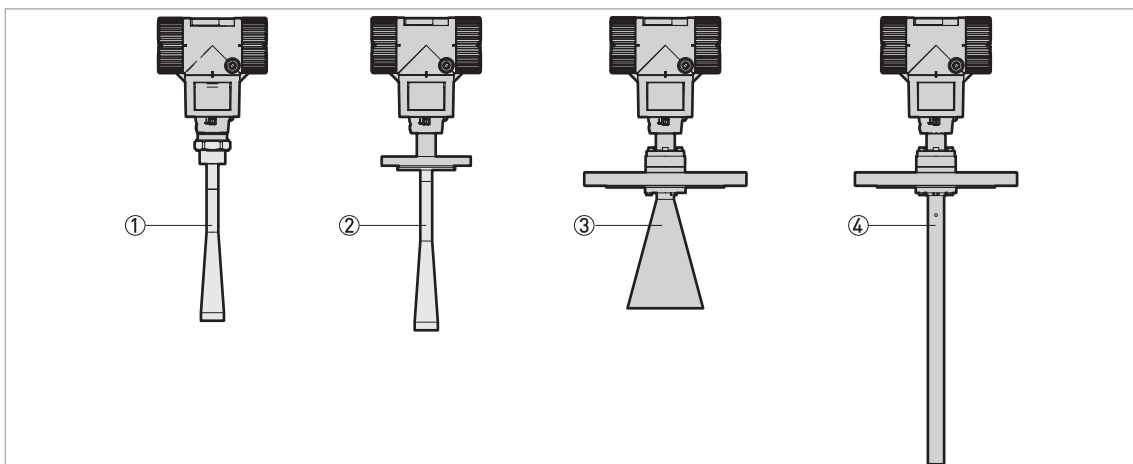

Figure 2-4: Types of antenna

- ① PP Wave Horn antenna (G 1½ or 1½ NPT threaded connection only)
- ② PTFE Wave Horn antenna (DN50...150 / 2"...6" flange connections)
- ③ Metallic Horn antenna (available antenna sizes: DN80 (3"), DN100 (4"), DN150 (6") and DN200(8"))
- ④ Wave Guide antenna (Length options: 1...6 m / 3.28...19.68 ft, in increments of 0.5 m / 1.64 ft)

If the process connection temperature is more than +150°C / +302°F, the device has a high-temperature (HT) extension. This is only available for Metallic Horn and Wave Guide antenna options.

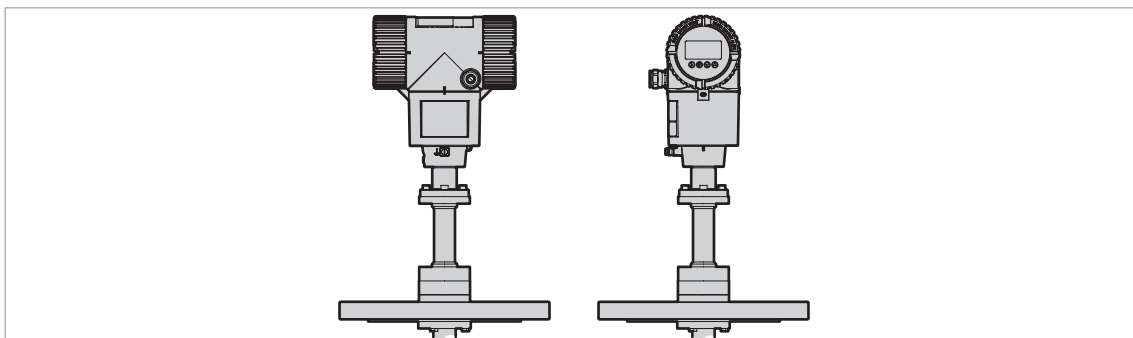

Figure 2-5: Signal converter with the HT extension

For more data about device options, refer to *Technical data* on page 91.

You can use the LCD display option or PACTware™ software installed on a computer or a workstation for device configuration. The device configuration menu has a quick set-up wizard. You usually will not need this document to install, set up and operate the device.

2.3 Visual Check



INFORMATION!

Inspect the cartons carefully for damages or signs of rough handling. Report damage to the carrier and to the local office of the manufacturer.

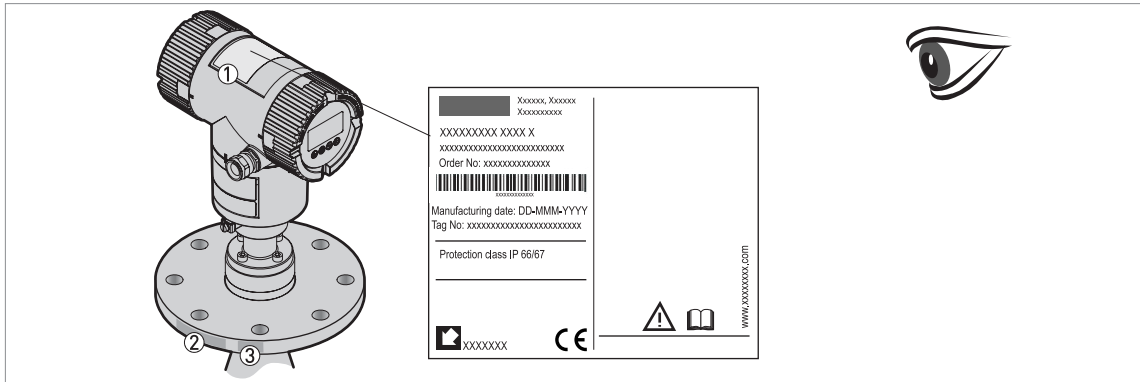

Figure 2-6: Visual check

- ① Device nameplate (for more data, refer to *Nameplate (examples)* on page 17)
- ② Process connection data (size and pressure rating, material reference and heat number)
- ③ Gasket material data - refer to the illustration that follows



Figure 2-7: Symbols for the supplied gasket material (on the side of the process connection)

- ① EPDM
- ② Kalrez® 6375

If the device is supplied with an FKM/FPM gasket, there is no symbol on the side of the process connection.

2.4 Nameplates



INFORMATION!

Look at the device nameplate to ensure that the device is delivered according to your order. Check for the correct supply voltage printed on the nameplate.

2.4.1 Nameplate (examples)

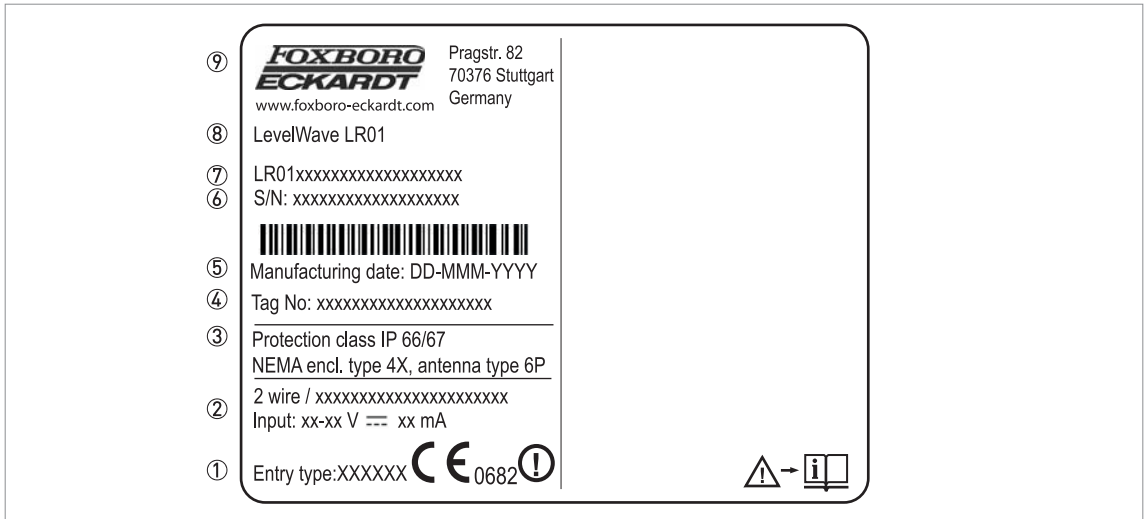

Figure 2-8: Compact and remote versions: Non-Ex nameplate attached to the housing

- ① Cable entry size
- ② Input / output option
- ③ Degree of ingress protection (according to EN 60529 / IEC 60529)
- ④ Customer tag number
- ⑤ Date of manufacture
- ⑥ Order number
- ⑦ Type code (defined in order)
- ⑧ Model name and number
- ⑨ Company name and address

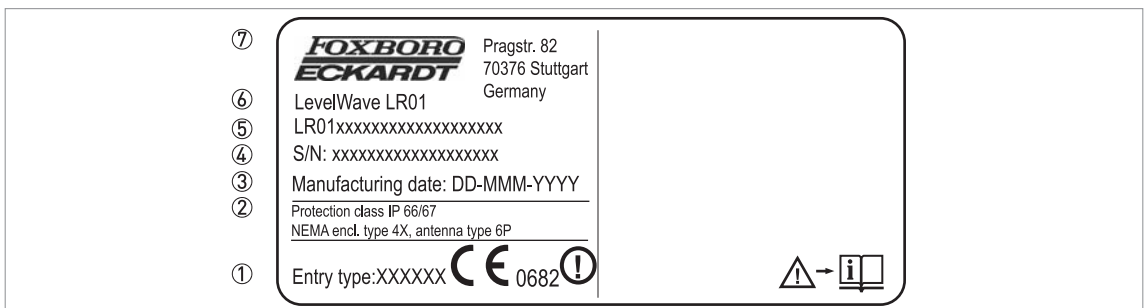

Figure 2-9: Remote version: Non-Ex nameplate attached to the antenna assembly

- ① Cable entry size
- ② Degree of ingress protection (according to EN 60529 / IEC 60529)
- ③ Date of manufacture
- ④ Order number
- ⑤ Type code (defined in order)
- ⑥ Model name and number
- ⑦ Company name and address

3 Installation

3.1 General notes on installation

**INFORMATION!**

Inspect the cartons carefully for damages or signs of rough handling. Report damage to the carrier and to the local office of the manufacturer.

**INFORMATION!**

Do a check of the packing list to make sure that you have all the elements given in the order.

**INFORMATION!**

Look at the device nameplate to ensure that the device is delivered according to your order. Check for the correct supply voltage printed on the nameplate.

3.2 Storage

**WARNING!**

Do not keep the device in a vertical position. This will damage the antenna and the device will not measure correctly.

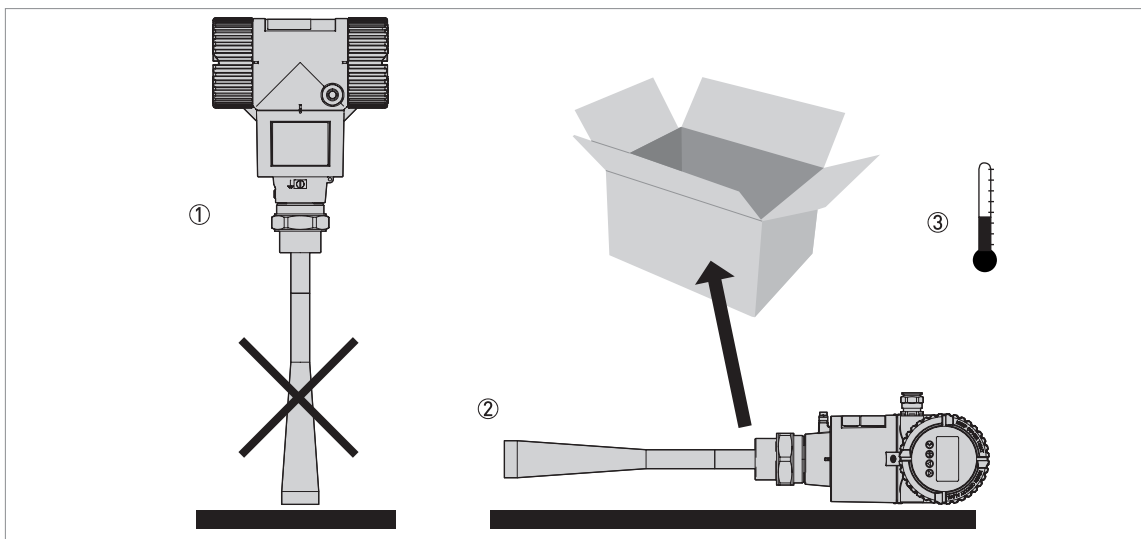

Figure 3-1: Storage conditions

- ① When you put the device into storage, do not keep it in a vertical position
- ② Put the device on its side. We recommend that you use the packaging in which it was delivered.
- ③ Storage temperature range: -40...+80°C / -40...+176°F

- Store the device in a dry and dust-free location.
- Store the device in its original packaging.

3.3 Transport



WARNING!

- *Depending on the version, the device will weight approx. 5...30 kg / 11...66 lbs. To carry, use both hands to lift the device carefully by the converter housing. If necessary, lift the device with a hoist.*
- *When handling the device, avoid hard blows, jolts, impact, etc. to prevent damage.*

3.4 Pre-installation requirements



INFORMATION!

Obey the precautions that follow to make sure that the device is correctly installed.

- Make sure that there is sufficient space on all sides.
- Protect the signal converter from direct sunlight. The device has a weather protection option.
- Do not subject the signal converter to heavy vibrations.

3.5 Installation

3.5.1 Pressure and temperature ranges



DANGER!

If the ambient temperature is more than +70°C / +158°F, there is a risk of injury if you touch the device. Use a protective cover or metallic grid to prevent injury.

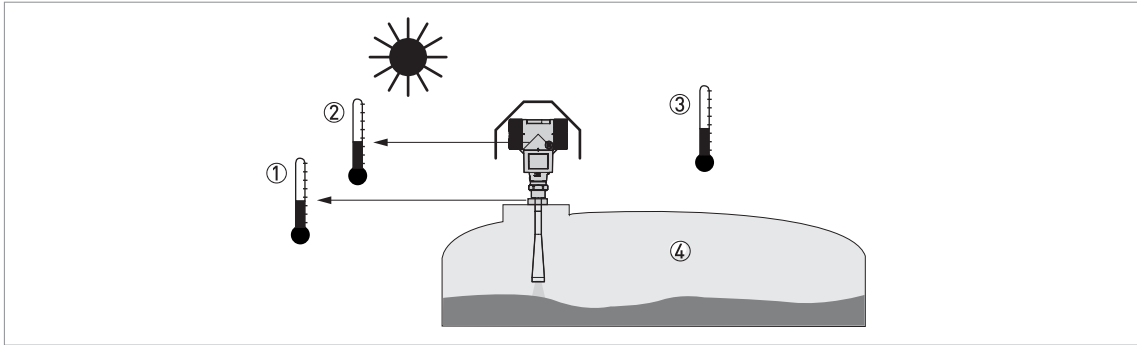

Figure 3-2: Pressure and temperature ranges

- ① Flange temperature
Non-Ex devices: Depends on the type of antenna, process connection and the seal material. Refer to the table that follows.
Ex devices: see supplementary operating instructions
- ② Ambient temperature for operation of the display
-20...+60°C / -4...+140°F
If the ambient temperature is not between these limits, the display screen switches off automatically. The device continues to operate.
- ③ Ambient temperature
Non-Ex devices: -40...+80°C / -40...+176°F
Ex devices: see supplementary operating instructions
- ④ Process pressure
Depends on the type of antenna and process connection. Refer to the table that follows.

Antenna type	Process connection	Seal	Process connection temperature		Process pressure	
			[°C]	[°F]	[barg]	[psig]
PP Wave Horn	G 1½; 1½ NPT	-	-20...+100	-4...+212	-1...16	-14.5...232
PTFE Wave Horn	Flange with PTFE plate	-	-50...+150	-58...+302	-1...40	-14.5...580
Metallic Horn Wave Guide	Flange	Metaglas® with FKM/FPM	-40...+200 ①	-40...+392 ①	-1...40 ②	-14.5...580 ②
		Metaglas® with Kalrez® 6375	-20...+250 ①	-4...+482 ①	-1...40 ②	-14.5...580 ②
		Metaglas® with PFA	-60...+130 ①	-76...+266 ①	-1...40 ②	-14.5...580 ②
		Metaglas® with EPDM	-50...+130 ①	-58...+266 ①	-1...40 ②	-14.5...580 ②

① Higher temperature on request
② Higher pressure on request

For more data on pressure ratings, refer to *Pressure ratings* on page 101

Ambient temperature / flange temperature, flange and threaded connection, in °C

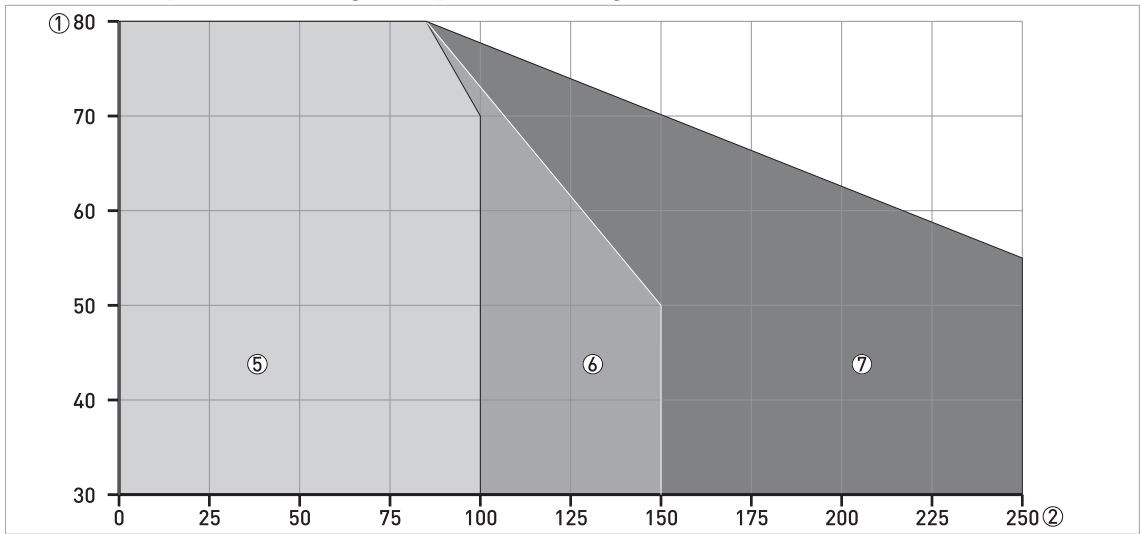

Figure 3-3: Ambient temperature / flange temperature, flange and threaded connection, in °C

Ambient temperature / flange temperature, flange and threaded connection, in °F

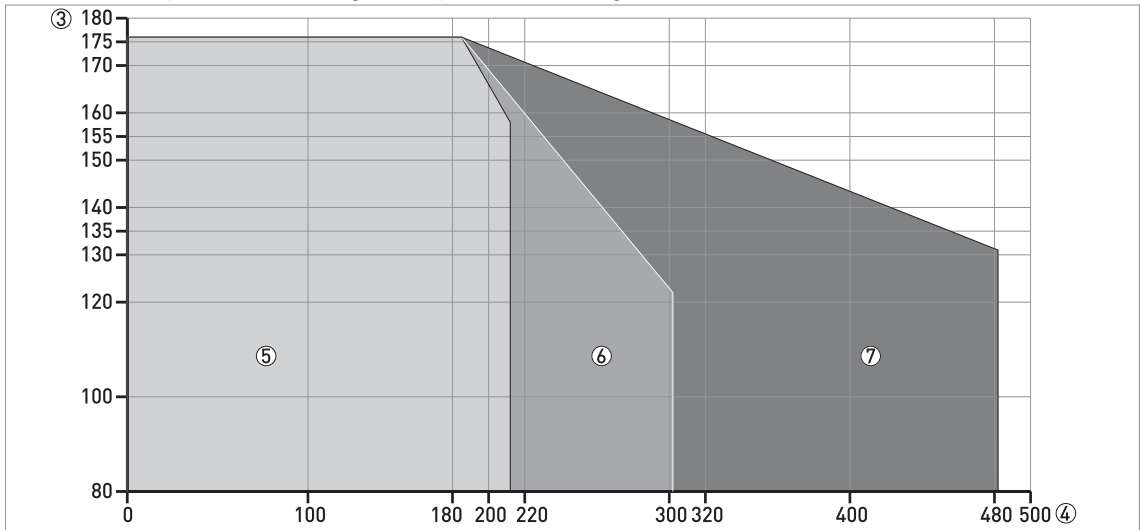

Figure 3-4: Ambient temperature / flange temperature, flange and threaded connection, in °F

- ① Maximum ambient temperature, °C
- ② Maximum flange temperature, °C
- ③ Maximum ambient temperature, °F
- ④ Maximum flange temperature, °F
- ⑤ PP Wave Horn antenna
- ⑥ PTFE Wave Horn antennas. Metallic Horn and Wave Guide antennas (standard temperature version).
- ⑦ Metallic Horn and Wave Guide antennas (high temperature version)

There is no change (de-rating) in ambient temperature below 0°C / 0°F. The process connection temperature must agree with the temperature limits of the gasket material. For pressure rating data, refer to *Pressure ratings* on page 101.

3.5.2 Recommended mounting position



CAUTION!

Follow these recommendations to make sure that the device measures correctly. They have an effect on the performance of the device.

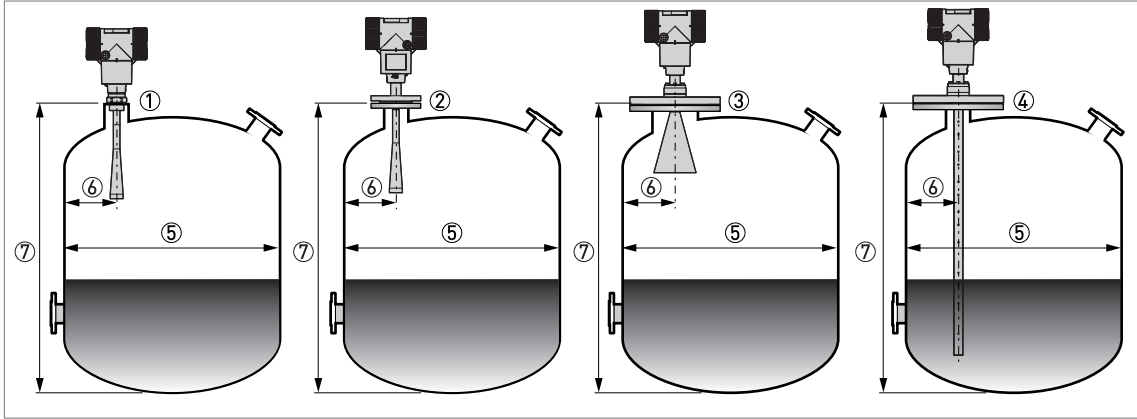

Figure 3-5: Recommended mounting position for liquids, pastes and slurries

- ① Sockets for the PP Wave Horn antenna
- ② Nozzles for the PTFE Wave Horn antenna
- ③ Nozzles for DN150 or DN200 Metallic Horn antennas
- ④ Nozzles for Wave Guide antennas
- ⑤ Tank diameter
- ⑥ Minimum distance of the nozzle or socket from the tank wall (depends on the antenna type and size - refer to items ①, ②, ③ and ④ in this list):
 - PP/PTFE Wave Horn (① and ②): $1/7 \times$ tank height
 - Metallic Horn (③): $1/10 \times$ tank height
 - Wave Guide (④): There is no minimum distance from the Wave Guide antenna to metallic walls and other metal objects
- Maximum distance of nozzle from the tank wall (depends on the antenna type and size - refer to items ①, ② and ③ in this list):
 - PP/PTFE Wave Horn (① and ②): $1/3 \times$ tank diameter
 - Metallic Horn (③): $1/3 \times$ tank diameter
 - Wave Guide (④): There is no maximum distance from the Wave Guide antenna to metallic walls and other metal objects
- ⑦ Tank height

Point the device in the correct direction

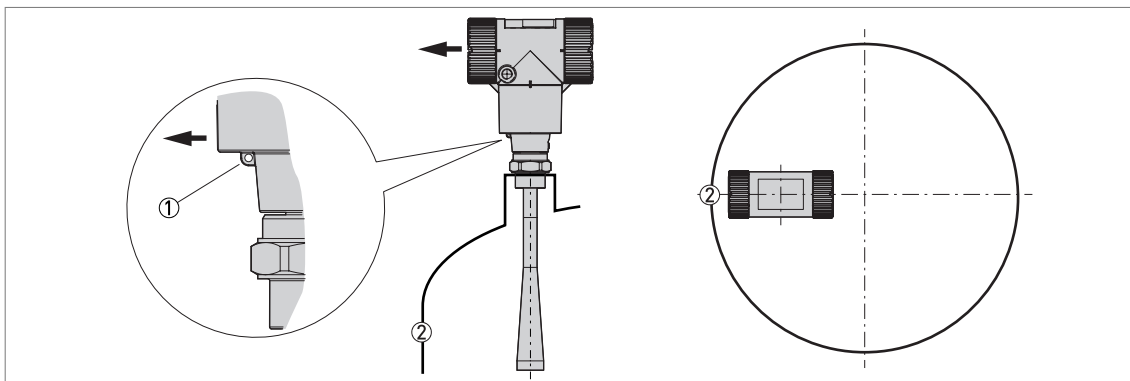

Figure 3-6: Point the device in the correct direction to get the best performance

Point the tag hole on the housing in the direction of the nearest tank wall.

- ① Tag hole
- ② Nearest tank wall

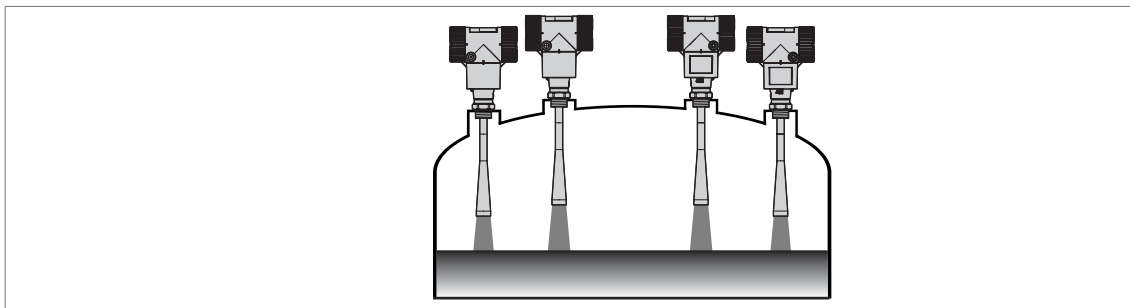

Figure 3-7: A maximum of 4 FMCW radar level meters can be operated in a tank

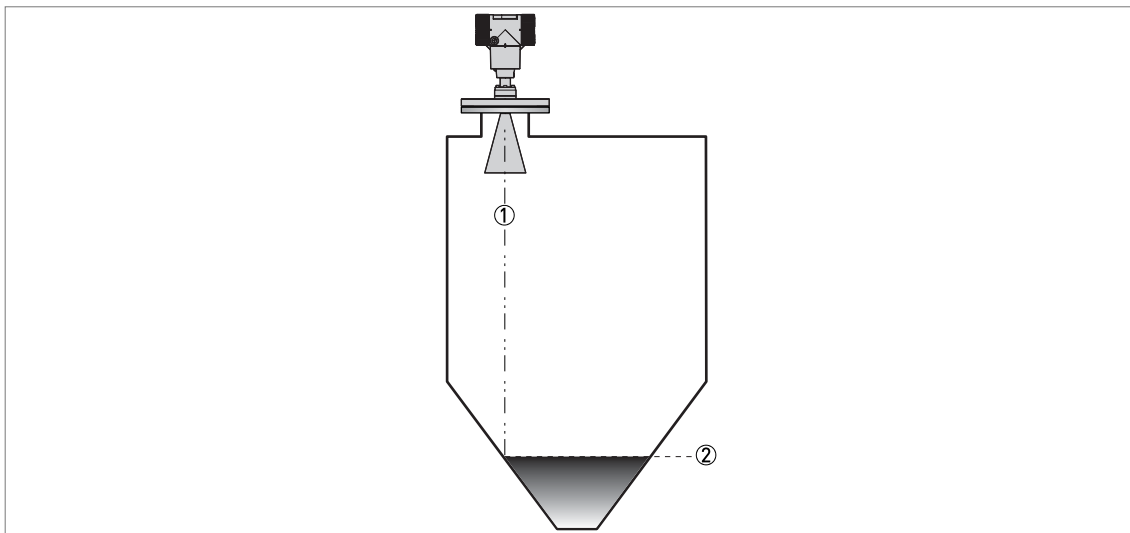

Figure 3-8: Tanks with conical bottoms

Conical bottoms have an effect on the measuring range. The device cannot measure to the bottom of the tank.

- ① Axis of radar beam
- ② Minimum level reading

3.5.3 Mounting restrictions



CAUTION!

Follow these recommendations to make sure that the device measures correctly. They have an effect on the performance of the device.

We recommend that you prepare the installation when the tank is empty.

Mounting restrictions: General data

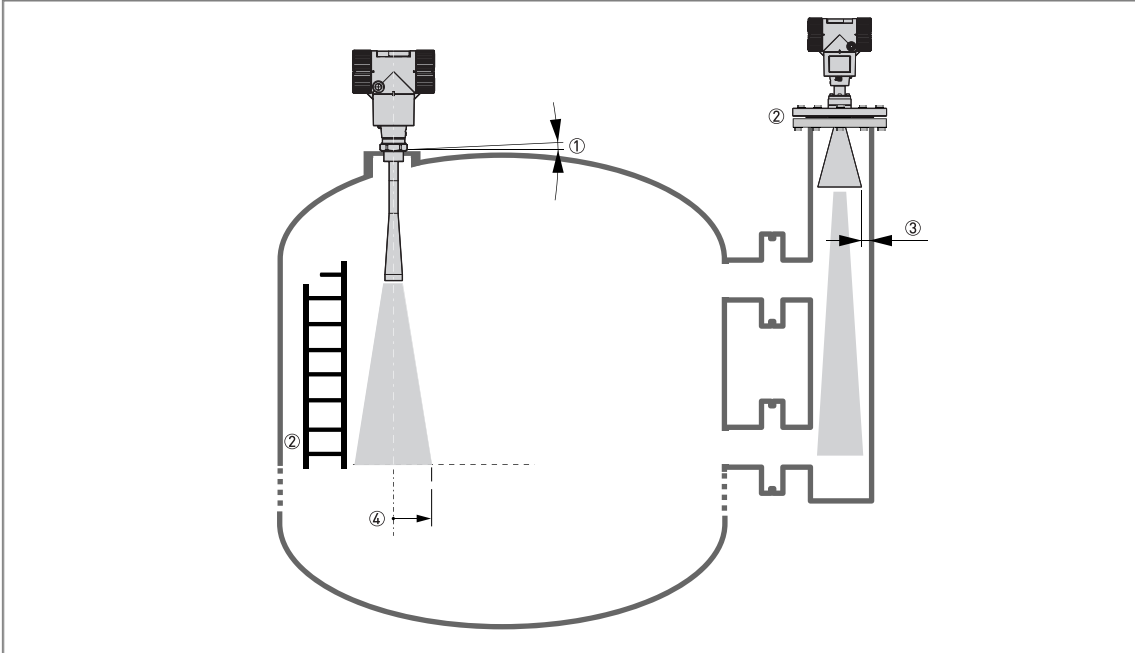

Figure 3-9: Mounting restrictions: General data

- ① Do not tilt the device more than 2°
- ② We recommend that you do an empty spectrum recording if there are too many obstacles in the radar beam (refer to **Operation**). If necessary, install a bypass chamber or stilling well or use an "S" antenna extension or a "L" antenna extension (the device must be installed on the side of the tank) to move the device away from obstacles.
- ③ 5 mm / 0.2" max. for high-dielectric constant liquids
- ④ Beam radius (DN80 (3") Metallic Horn antenna): increments of 290 mm/m or 3.4"/ft (16°)
 Beam radius (DN100 (4") Metallic Horn antenna): increments of 210 mm/m or 2.6"/ft (12°)
 Beam radius (DN150 (6") Metallic Horn antenna): increments of 140 mm/m or 1.7"/ft (8°)
 Beam radius (DN200 (8") Metallic Horn antenna): increments of 100 mm/m or 1.3"/ft (6°)
 Beam radius (PP Wave Horn and PTFE Wave Horn antenna): increments of 176 mm/m or 2.1"/ft (10°)

Obstacles in the tank

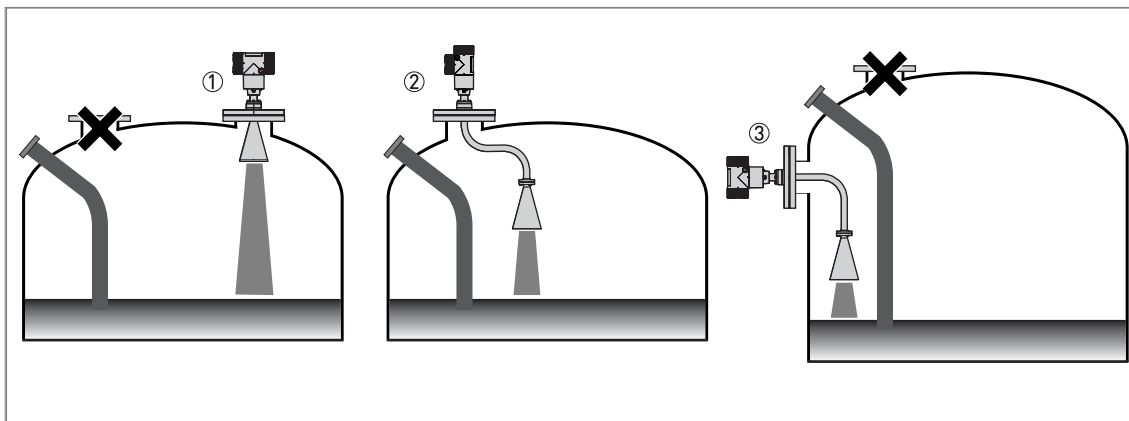

Figure 3-10: Obstacles in the tank

Do not put the device directly above obstacles (agitator, support beams, heating tubes etc.). Parasitic signals from obstacles will cause the device to measure incorrectly.

- ① Solution 1: Put the device on another process connection away from obstacles
- ② Solution 2: Use the same process connection, but also use an "S" extension
- ③ Solution 3: Attach the device to the side of the tank and use an "L" (right angle) extension



CAUTION!

Do not put the device near to the product inlet. If the product that enters the tank touches the antenna, the device will measure incorrectly. If the product fills the tank directly below the antenna, the device will also measure incorrectly.

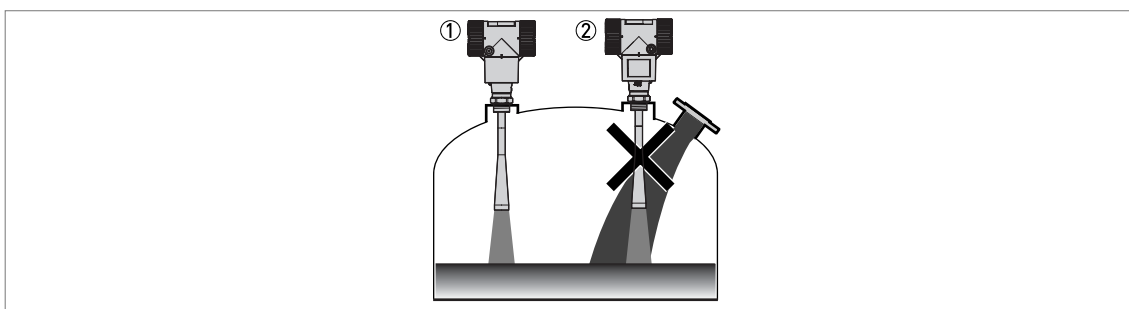

Figure 3-11: Product inlets

- ① The device is in the correct position.
- ② The device is too near to the product inlet.

Devices with Metallic Horn antenna

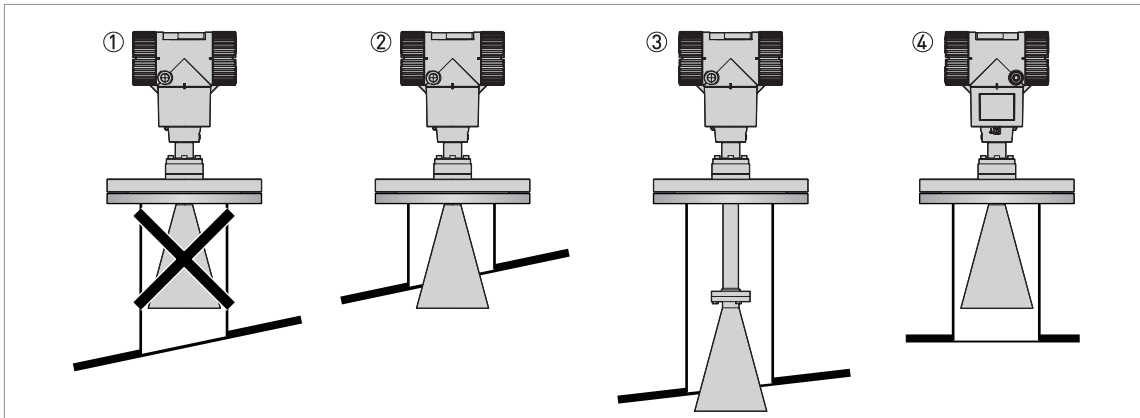

Figure 3-12: Devices with Metallic Horn antenna

- ① If the roof is not flat, the antenna must project out of the nozzle
- ② Short tank nozzle
- ③ Long tank nozzle (device with an antenna extension)
- ④ If the roof is flat and the tank fitting is symmetrical, it is not necessary for the antenna to project out of the nozzle. Thus, the device can have a larger measuring range.

The antenna must project out of the nozzle. If necessary, use an antenna extension. But if the tank roof is flat and the tank fitting is symmetrical, it is not necessary for the antenna to project out of the nozzle. Thus, the device can have a larger measuring range.

Devices with PTFE or PP Wave Horn antenna

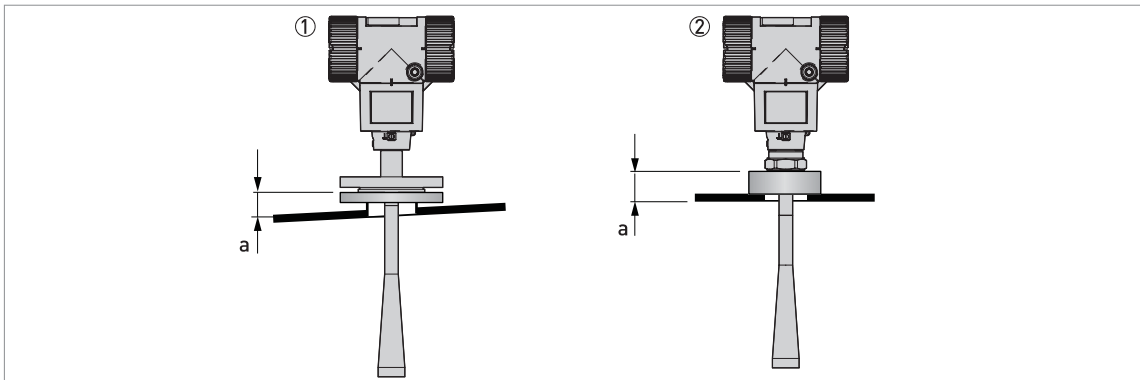

Figure 3-13: Devices with PTFE or PP Wave Horn antenna

Recommended height of tank process connection, $a = 44...200 \text{ mm} / 1.7...7.87''$

- ① Device with a PTFE Wave Horn antenna and a flange connection. There are antenna extension options available (100 mm / 4", 200 mm / 8" and 300 mm / 12") for long nozzles.
- ② Device with a PP Wave Horn antenna and a thread connection



CAUTION!

If there are parasitic signals, the device will not measure correctly. Parasitic signals are caused by:

- Objects in the tank.
- Sharp corners that are perpendicular to the path of the radar beam.
- Sudden changes in tank diameter in the path of the radar beam.

Do an Empty Spectrum recording (refer to **Operation**) to remove parasitic signals with a filter.

Requirements for flange connections

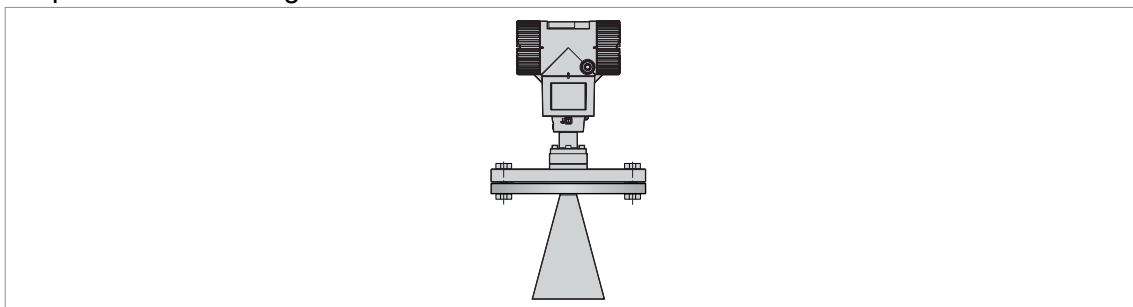

Figure 3-14: Flange connection

Equipment needed:

- Device
- Flange gasket (not supplied)
- Wrench (not supplied)



- Make sure the flange on the nozzle is level.
- Make sure that you use the applicable gasket for the flange dimensions and the process.
- Align the gasket correctly on the flange facing of the nozzle.
- Lower the antenna carefully into the tank.
- Make sure that you point the device in the correct direction. Refer to "Point the device in the correct direction" in this section.
- Tighten the flange bolts.
- ➡ Refer to local rules and regulations for the correct torque to apply to the bolts.

Requirements for threaded connections

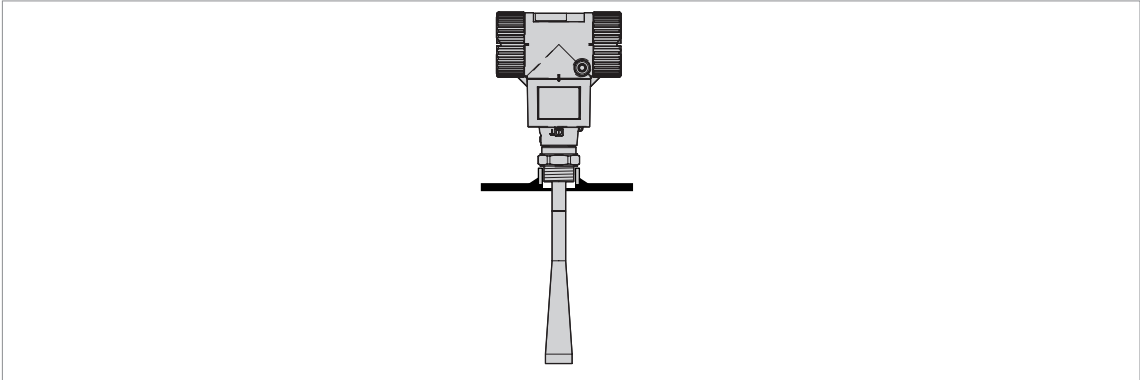

Figure 3-15: Threaded connection

Equipment needed:

- Device
- Gasket for G 1½ connection (not supplied)
- Thread seal tape (PTFE) for 1½ NPT connection (not supplied)
- 50 mm / 2" wrench (not supplied)



WARNING!

Do not tighten the connection to a torque more than 40 Nm. If the connection is too tight, this will damage the thread.

To prevent damage to the antenna, make sure that the minimum diameter of the hole for a 1½ NPT thread connection is not less than 43.4 mm / 1.71".



- Make sure the tank connection is level.
- **ISO 228-1 (G) connection:** Make sure that you use the applicable gasket for the connection dimensions and the process.
- **ISO 228-1 (G) connection:** Align the gasket correctly.
- **NPT connection:** Wind the thread seal tape around the process connection in agreement with good engineering practice.
- Lower the antenna carefully into the tank.
- Turn the threaded connection on the antenna to attach the device to the process connection.
- Make sure that you point the device in the correct direction. Refer to "Point the device in the correct direction" in this section.
- Tighten the connection to the correct torque (not more than 40 Nm).

3.5.4 Standpipes (stilling wells and bypass chambers)

Use a standpipe if:

- There is highly conductive foam in the tank.
- The liquid is very turbulent or agitated.
- There are too many other objects in the tank.
- The device is measuring a liquid (petro-chemicals) in a tank with a floating roof.
- The device is installed in a horizontal cylindrical tank (refer to the end of this section)

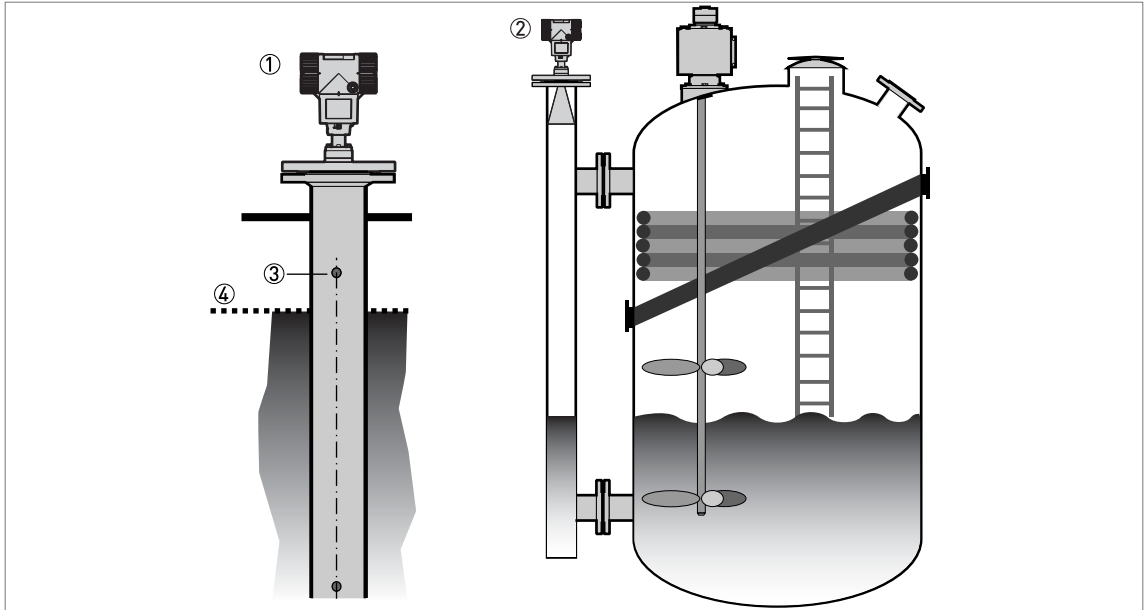

Figure 3-16: Installation recommendations for standpipes (stilling wells and bypass chambers)

- ① A stilling well solution
- ② A bypass chamber solution
- ③ Air circulation hole
- ④ Level of the liquid



CAUTION!

Installation requirements

- *The standpipe must be electrically conductive.*
- *The inside diameter of the standpipe must not be more than 5 mm / 0.2" over the diameter of the antenna (for a high-dielectric constant liquid).*
- *The standpipe must be straight. There must be no sudden changes in internal diameter greater than 1 mm / 0.04".*
- *The standpipe must be vertical.*
- *Recommended surface roughness: $<\pm 0.1$ mm / 0.004".*
- *Make sure that there are no deposits at the bottom of the standpipe.*
- *Make sure that there is liquid in the standpipe.*

Stilling wells - general notes



Installation in tanks containing one liquid and foam

- Drill an air circulation hole (max. $\text{Ø}10 \text{ mm} / 0.4''$) in the stilling well above the maximum level.
- Remove the burr from the hole.



Installation in tanks containing one liquid or more without foam

- Drill an air circulation hole (max. $\text{Ø}10 \text{ mm} / 0.4''$) in the stilling well above the maximum level.
- Drill 1 or more liquid circulation holes in the stilling well (if there is more than 1 liquid in the tank).
- ➔ These holes help the liquid to move freely between the stilling well and the tank.
- Remove the burr from the hole.

Stilling wells: floating roofs

If the device must be installed on a tank with a floating roof, install it in a stilling well.

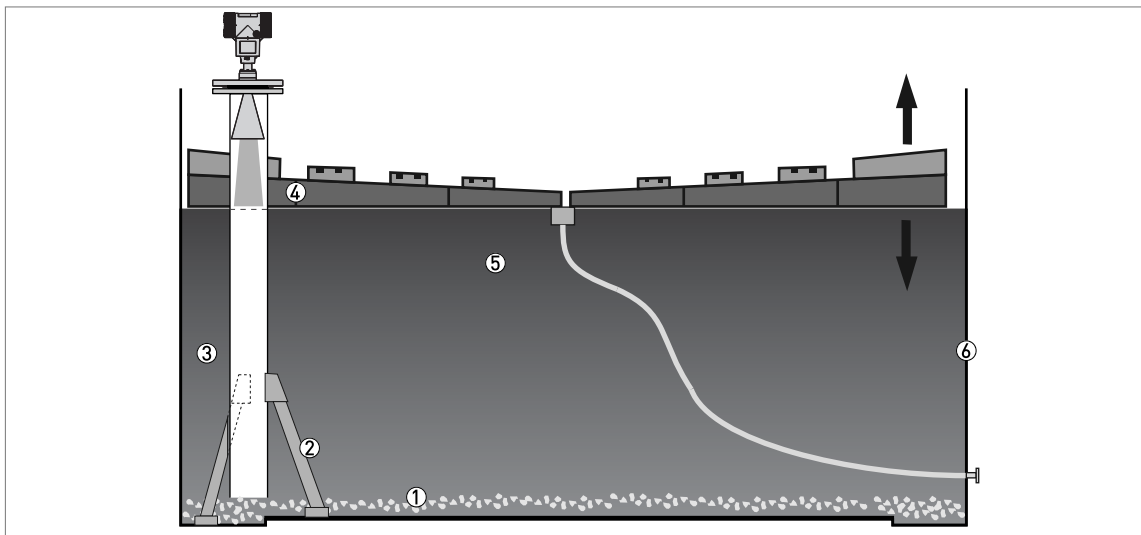

Figure 3-17: Floating roofs

- ① Sediment
- ② Support fixtures
- ③ Stilling well
- ④ Floating roof
- ⑤ Product
- ⑥ Tank

Stilling wells: horizontal cylindrical tanks

We recommend that you install the device in a stilling well if the device:

- is for a horizontal cylindrical tank,
- is in a metallic tank,
- measures a product with a high dielectric constant and
- is on the centerline of the tank.

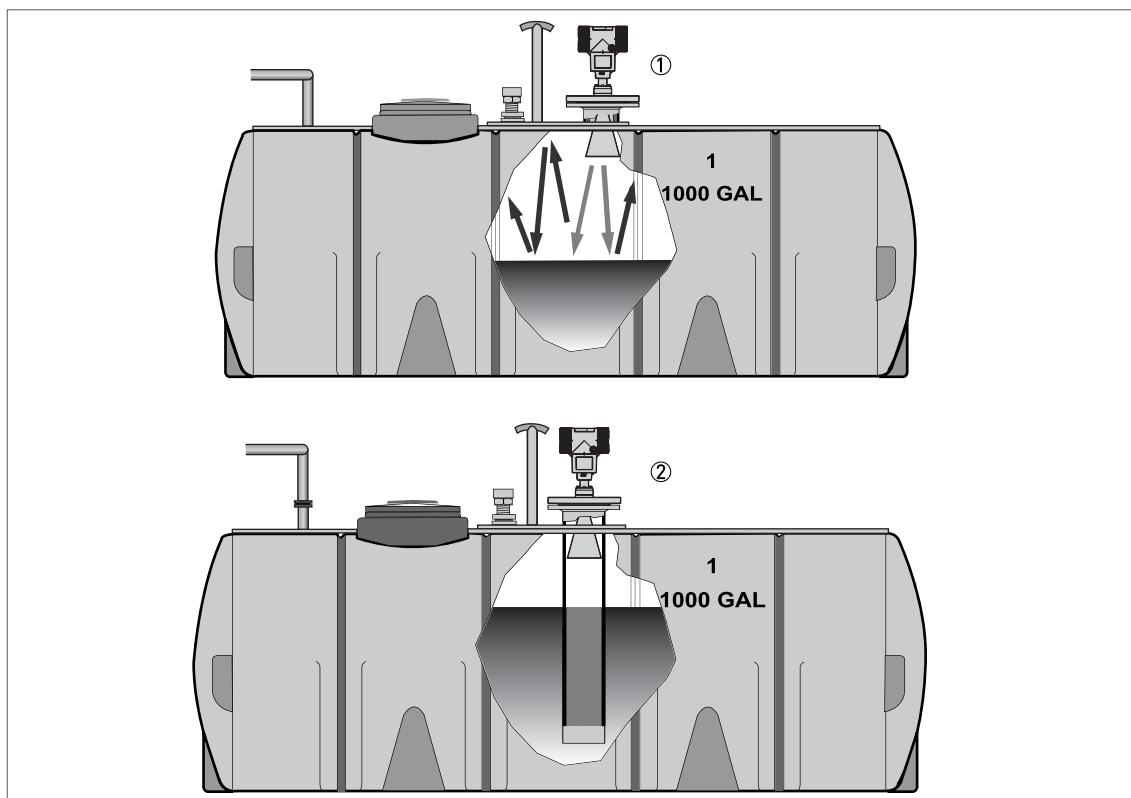

Figure 3-18: Horizontal cylindrical tanks

- ① The device is installed without a stilling well. There are multiple reflections. Refer to the CAUTION! that follows.
- ② The device is installed in a stilling well and measures correctly.



CAUTION!

If the device is installed in horizontal cylindrical tank that contains a high dielectric constant liquid without a stilling well, do not put it on the tank centerline. This will cause multiple reflections and the device will not measure accurately. Use the **2.3.12 Multiple Reflections** function in **Supervisor > Basic Parameters** to keep the effects of multiple reflections to a minimum. For more data, refer to Function description on page 65 (2. Supervisor).

Bypass chambers

Installation next to tanks containing one liquid and foam

- The top process connection of the bypass chamber must be above the maximum level of liquid.
- The bottom process connection of the bypass chamber must be below the lowest measured level of liquid.

Installation next to tanks containing more than one liquid

- The top process connection of the bypass chamber must be above the maximum level of liquid.
- The bottom process connection of the bypass chamber must be below the lowest measured level of liquid.
- Additional process connections are necessary for the liquids to circulate freely along the length of the bypass chamber.

3.5.5 Wall support for the remote version

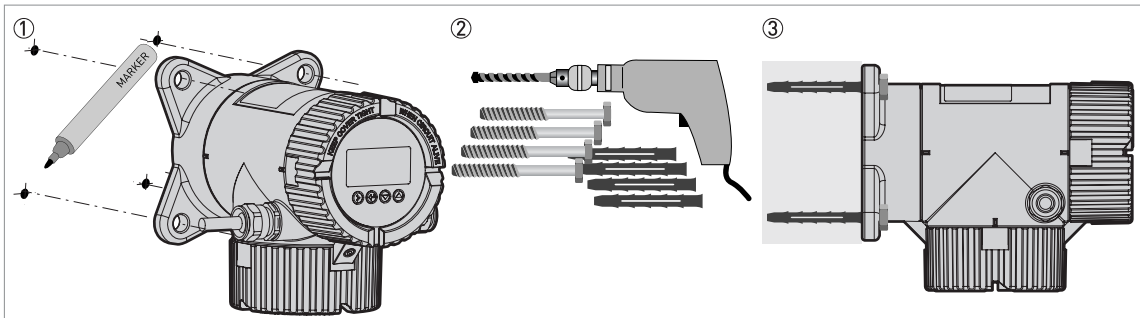

Figure 3-19: Wall support for the remote version (attached to the remote converter)



- ① Use marks on the wall to help you put the wall support in the correct position. For more data, refer to *Dimensions and weights* on page 108.
- ② Use equipment and tools that agree with health and safety regulations and good engineering practice.
- ③ Make sure the wall support is correctly attached to the wall.

3.5.6 How to attach an antenna extension (Metallic Horn or Wave Guide antennas)



CAUTION!

IF THE ANTENNA EXTENSION IS SUPPLIED WITH THE DEVICE AS AN OPTION:

If the antenna extension is attached to the device, no more work is necessary.

If the antenna extension is not attached to the device, refer to Procedure 1 in this section. It is not necessary to change the device settings. The manufacturer sets the related menu items to the correct values in the factory.

IF THE ANTENNA EXTENSION IS SUPPLIED AFTER DELIVERY OF THE DEVICE (SPARE PART):

You must attach the antenna extension to the device and change the device settings in the SUPERVISOR menu. If you have a straight antenna extension, refer to Procedures 1 and 2A. If you have an "S" or "L" (right-angle) antenna extension, refer to Procedures 1 and 2B.



DANGER!

If you installed the device on the tank before the procedure, make the device safe (de-energize the circuit, clean the device etc.) before you continue the work.

Equipment needed

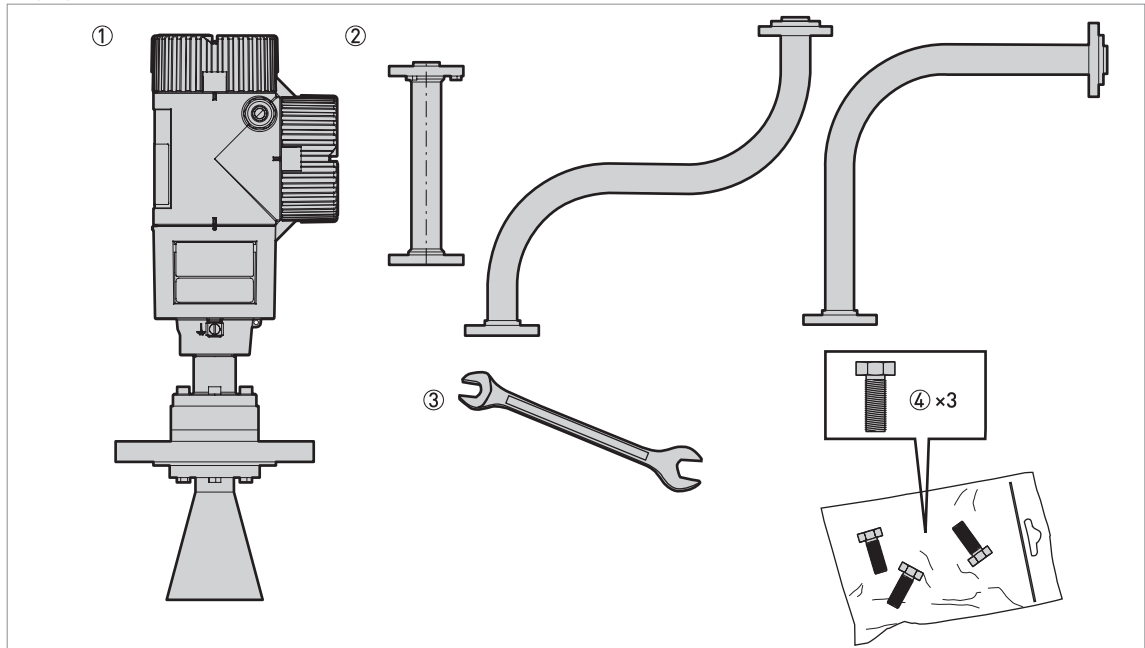

Figure 3-20: Equipment needed

- ① Device (with a Metallic Horn or Wave Guide antenna option only)
- ② Antenna extension. From left to right: straight, "S" and "L" (right-angle) extension.
- ③ 10 mm open-end or box-end wrench (not supplied)
- ④ 3 hex head screws M6x25-A4-70 (supplied in a plastic sachet)

Obey the assembly procedure that follows:

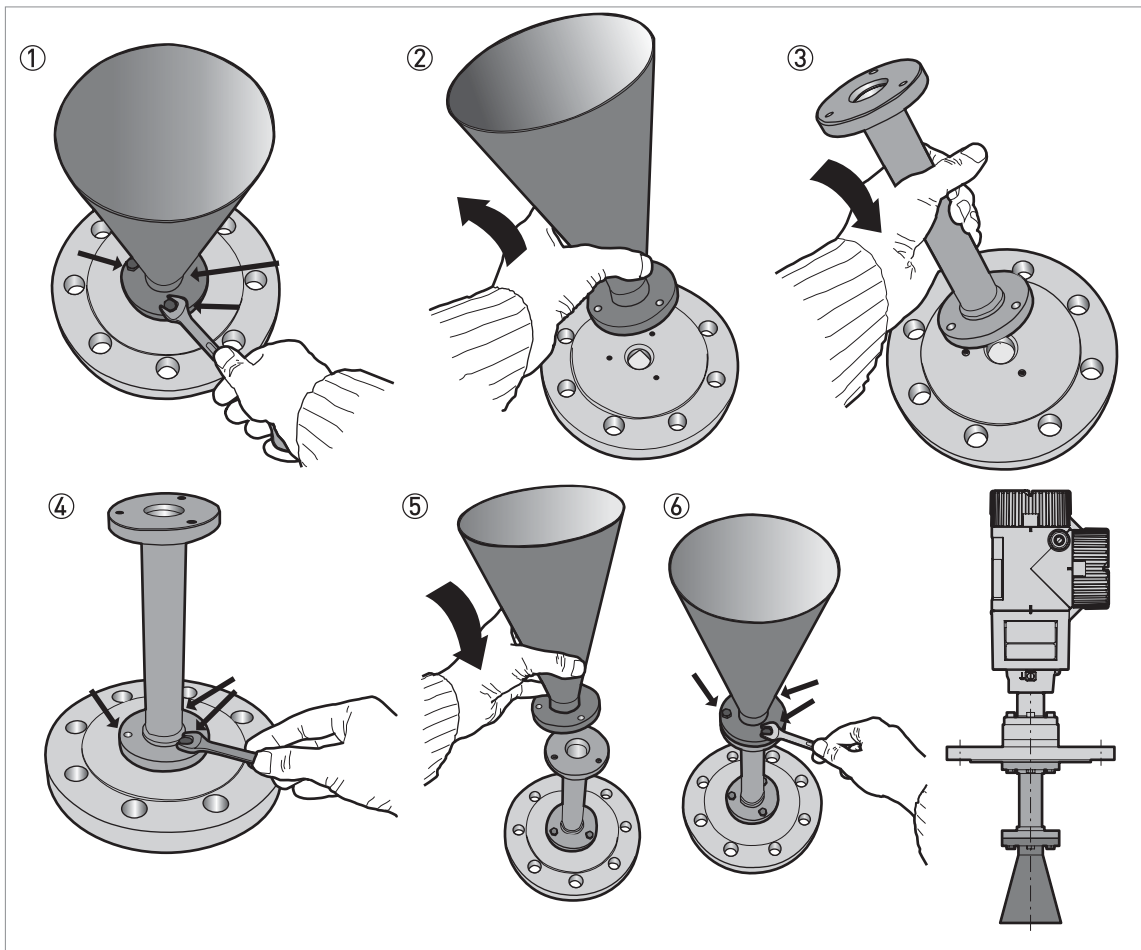

Figure 3-21: Procedure: How to attach an antenna extension



WARNING!

Make sure that you do not damage the PTFE cone when you remove or install the antenna.



Procedure 1: How to attach an antenna extension

- ① Remove the 3 hex head screws from the antenna with the 10 mm wrench.
- ② Remove the antenna. Make sure that you do not damage the PTFE cone when you remove the antenna.
- ③ Attach the antenna extension below the flange. Make sure that the antenna extension is fully engaged. Make sure that you do not damage the PTFE cone when you attach the antenna extension.
- ④ Attach 3 hex head screws to the antenna extension with a 10 mm wrench. Tighten the screws to a torque of 8 Nm.
- ⑤ Attach the antenna below the antenna extension.
- ⑥ Attach 3 hex head screws to the antenna with a 10 mm wrench. Tighten the screws to a torque of 8 Nm.
- ➡ If the antenna extension is supplied with the device, it is not necessary to change the device settings. End of the procedure.
- ⑦ If the antenna extension is supplied after delivery of the device, it is necessary to change the device settings. Make a selection from one of the procedures (2A or 2B) that follow: straight antenna extension, "S" antenna extension or "L" (right angle) antenna extension.



Procedure 2A: Device settings for a device with a straight antenna extension

- Enter the SUPERVISOR menu (2.0.0).
- Push [➤], 2 × [▲], [➤] and 6 × [▲] to go to menu item ANTENNA EXTENSION (2.3.7).
- Push [➤] to change the value. Push [➤] to change the position of the cursor. Push [▼] to decrease the value or [▲] to increase the value.
- ➡ If the antenna extension has a length of 500 mm, enter the value "500" (if units for this menu item are in mm).
- Push 3 × [←] to go back to the "STORE" screen.
- Push [▲] or [▼] to set the screen to **STORE YES** and push [←].
- ➡ End of the procedure.



Procedure 2A: Device settings for a device with an "S" or L" (right angle) antenna extension

- Enter the SUPERVISOR menu (2.0.0).
- Push [➤], 2 × [▲], [➤] and 6 × [▲] to go to menu item ANTENNA EXTENSION (2.3.7).
- Push [➤] to change the value. Push [➤] to change the position of the cursor. Push [▼] to decrease the value or [▲] to increase the value.
- ➡ If units are in mm, enter the value "243" (for an "S" extension) or "236" (for an "L" extension).
- Push [←] to go back to the menu. Push 2 × [▲] to go to menu item DIST.PIECE (2.3.9).
- Push [➤] to change the value. Push [➤] to change the position of the cursor. Push [▼] to decrease the value or [▲] to increase the value.
- ➡ If units are in mm, enter the value "221" (for an "S" extension) or "236" (for an "L" extension).
- Push 3 × [←] to go back to the "STORE" screen.
- Push [▲] or [▼] to set the screen to **STORE YES** and push [←].
- ➡ End of the procedure.

Settings for devices with antenna extensions in mm

Antenna extension type	Device settings	
	ANTENNA EXTENSION (2.3.7)	DIST.PIECE (2.3.9)
Straight	①	0 ②
"S"	243	221 ②
"L" (right angle)	236	236 ②

① This value depends on the length of the antenna extension. Enter the length of the antenna extension: 100, 200, 300, 400, 500 or 1000 mm

② If the device has a high temperature extension, add 120 mm to this value

3.5.7 How to turn or remove the signal converter

The converter turns 360°, but we recommend that the tag hole on the housing points to the nearest tank wall. For more data, refer to *Recommended mounting position* on page 22. The converter can be removed from the process connection assembly under process conditions.

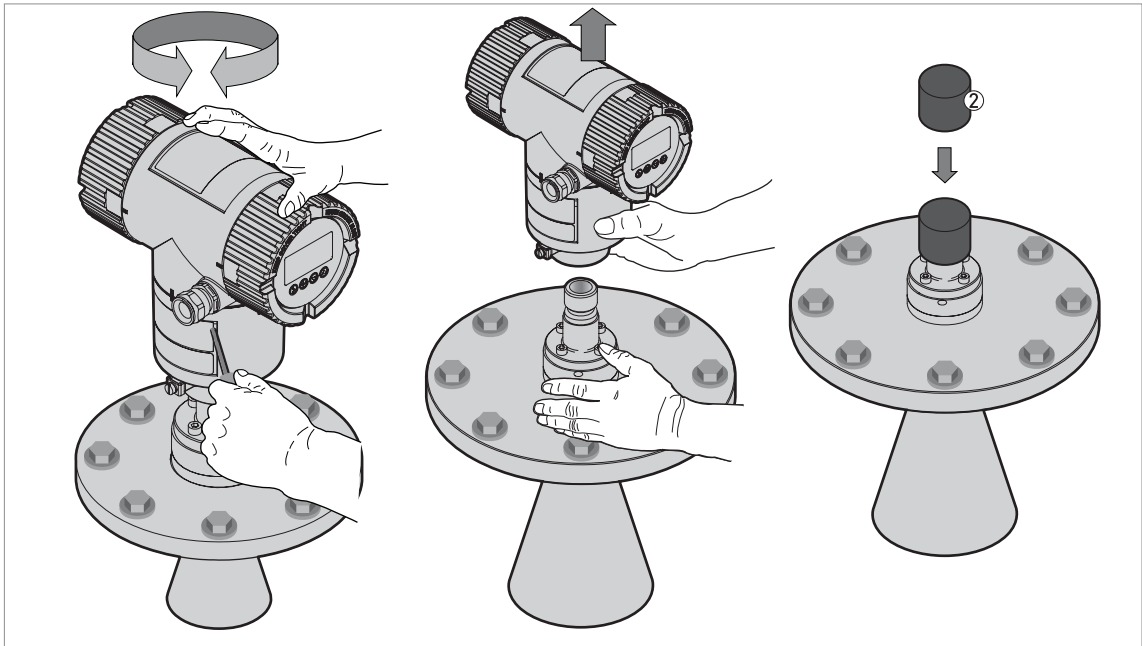

Figure 3-22: How to turn or remove the signal converter

- ① Tool: 5 mm Allen wrench (not supplied) for the lock screw on the signal converter
- ② Cover for the wave guide hole on top of the process connection assembly (not supplied)



CAUTION!

Do not loosen the 4 socket head screws on the process connection assembly. If you remove the housing, put a cover on the the wave guide hole on top of the process connection assembly. Make sure that the wave guide hole is clean and dry. When the housing is attached to the process connection assembly, tighten the lock screw with the 5 mm Allen wrench ①.

3.5.8 How to attach the weather protection to the device

The device and the weather protection option are supplied disassembled in the same box. You must attach the weather protection when you install the device.

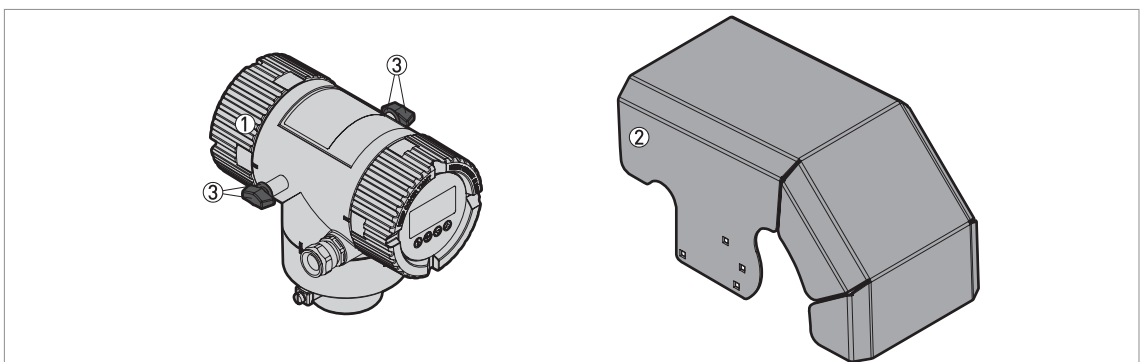

Figure 3-23: Equipment needed

- ① Device
- ② Weather protection (option).
- ③ 2 butterfly screws and spring washers. The manufacturer attaches these parts to the device before delivery.

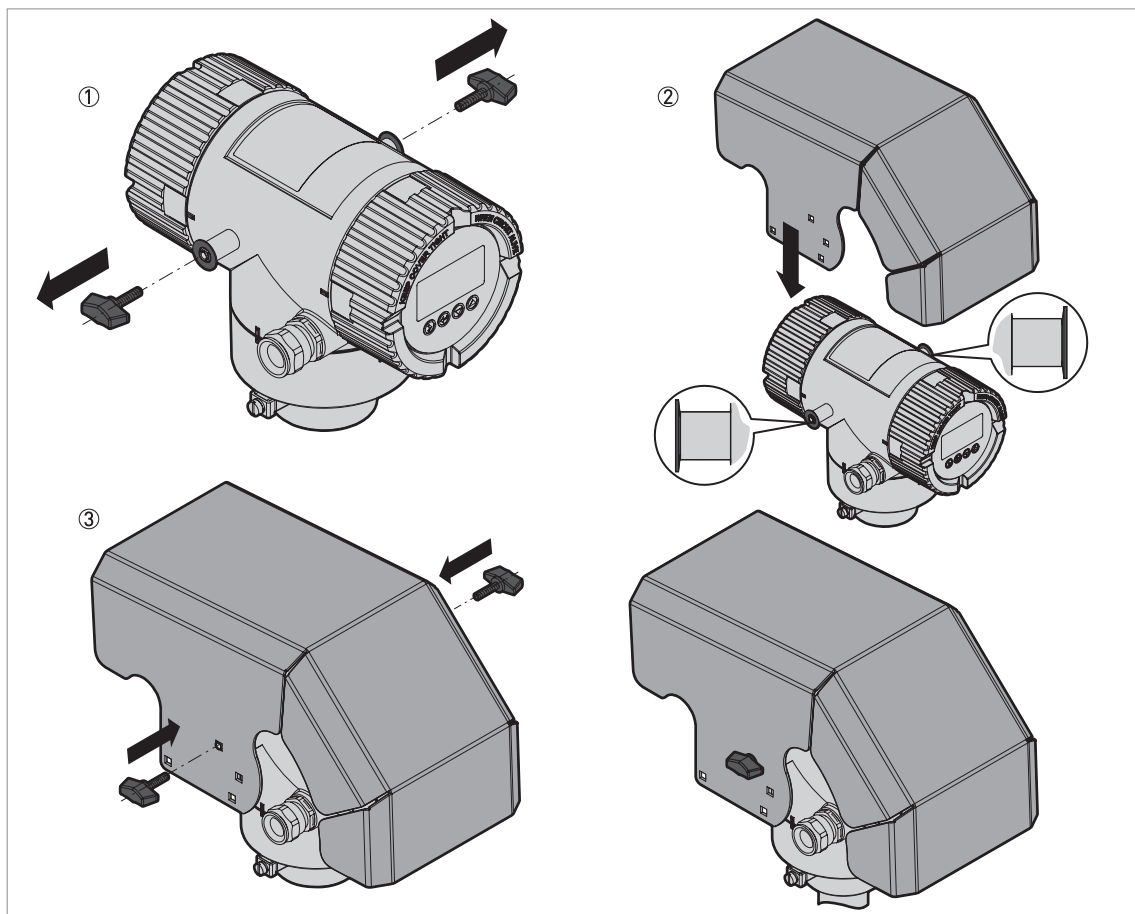

Figure 3-24: Installation of the weather protection (general procedure)



- ① Remove the 2 butterfly screws from the housing. Make sure that spring washer is attached correctly to the housing (on the weather protection fixture).
- ② Lower the weather protection onto the device.
- ③ Attach the 2 butterfly screws. Make sure that you use the correct holes to attach the weather protection. The holes must agree with the housing option used (compact vertical (non-Ex or Ex i-approved etc.)). For more data, refer to the illustration that follows:

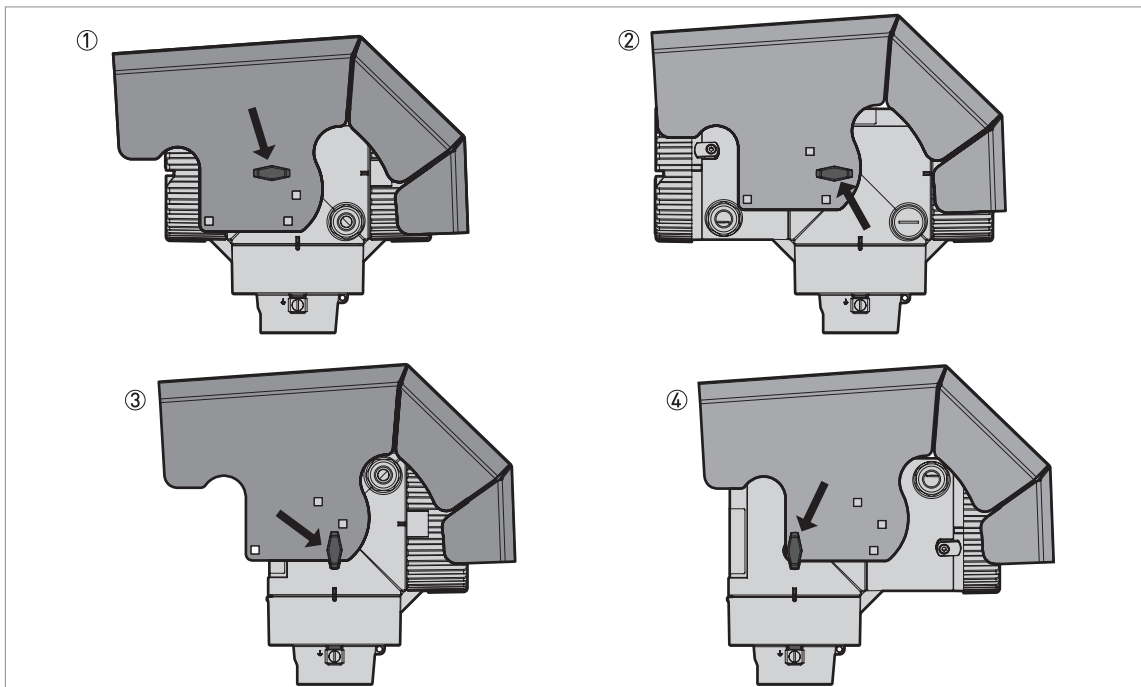

Figure 3-25: Holes for installation of the weather protection (housing versions)

- ① Compact horizontal housing (non-Ex and Ex i-approved devices)
- ② Compact horizontal housing (Ex d-approved devices)
- ③ Compact vertical housing (non-Ex and Ex i-approved devices)
- ④ Compact vertical housing (Ex d-approved devices)

The overall dimensions of the weather protection are on page 108.

3.5.9 How to open the weather protection

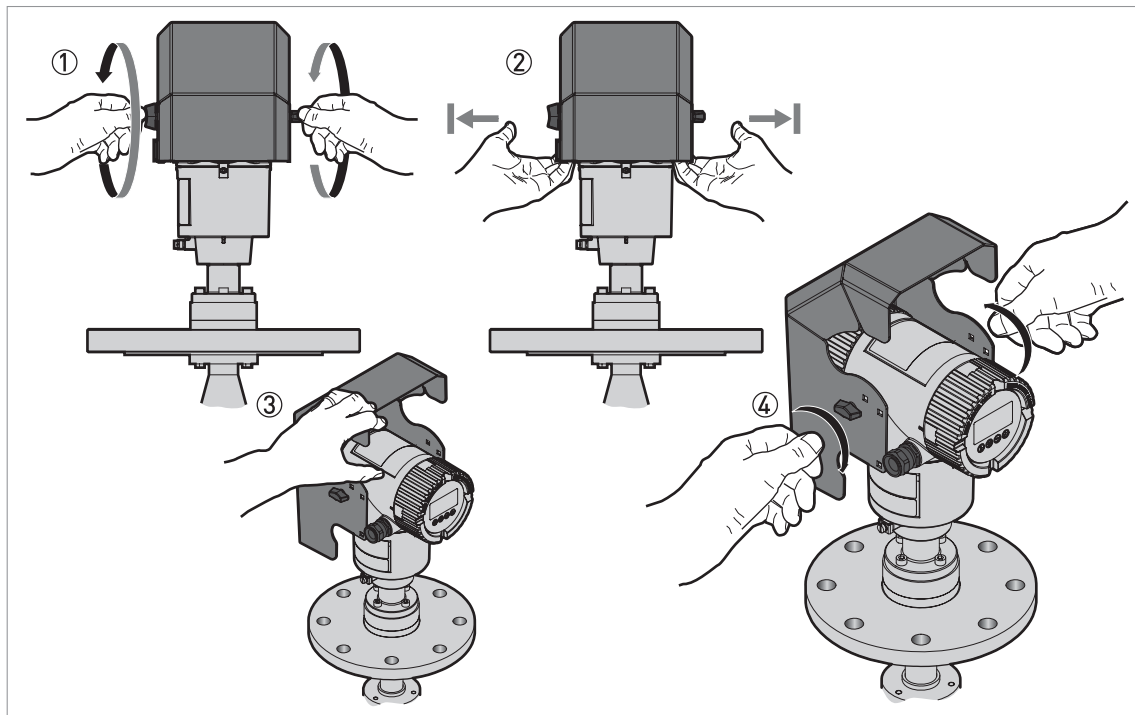

Figure 3-26: How to open the weather protection



- ① Loosen the bolt on each side of the weather protection.
- ② Pull the sides of the weather protection out of the notch for the closed position.
- ③ Pull the weather protection up and back.
- ➡ This will open the weather protection.
- ④ Tighten the bolts to lock the weather protection in its open position.

4 Electrical connections

4.1 Safety instructions



DANGER!

All work on the electrical connections may only be carried out with the power disconnected. Take note of the voltage data on the nameplate!



DANGER!

Observe the national regulations for electrical installations!



DANGER!

For devices used in hazardous areas, additional safety notes apply; please refer to the Ex documentation.



WARNING!

Observe without fail the local occupational health and safety regulations. Any work done on the electrical components of the measuring device may only be carried out by properly trained specialists.



INFORMATION!

Look at the device nameplate to ensure that the device is delivered according to your order. Check for the correct supply voltage printed on the nameplate.

4.2 Electrical installation: 2-wire, loop-powered

4.2.1 Compact version

Terminals for electrical installation

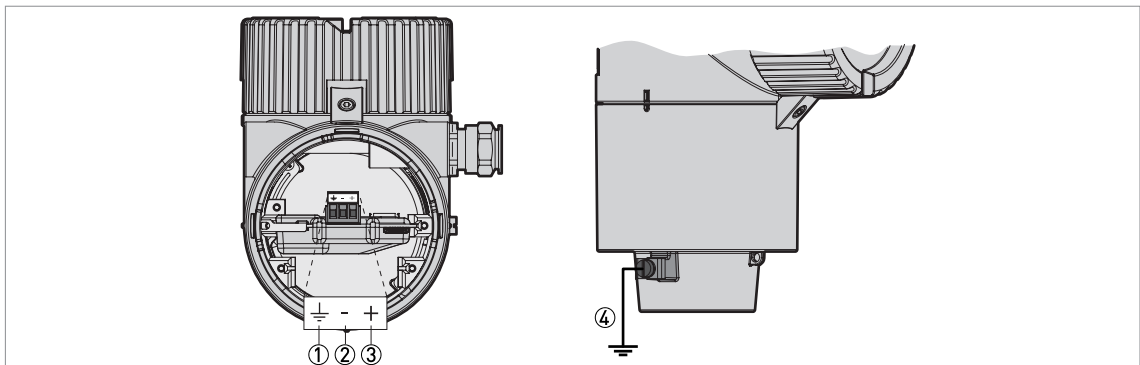

Figure 4-1: Terminals for electrical installation

- ① Grounding terminal in the housing (if the electrical cable is shielded)
- ② Current output -
- ③ Current output +
- ④ Location of the external grounding terminal (at the bottom of the converter)



INFORMATION!

Electrical power to the output terminal energizes the device. The output terminal is also used for HART® communication.

**CAUTION!**

- Use the applicable electrical cables with the cable glands.
- Make sure that the power supply does not have a current more than 5 A or that there is 5 A-rated fuse in the electrical circuit that energizes the device.
- Make sure that the polarity of the power supply is correct. If the polarity is incorrect, you will not cause damage to the device but the device will not operate.

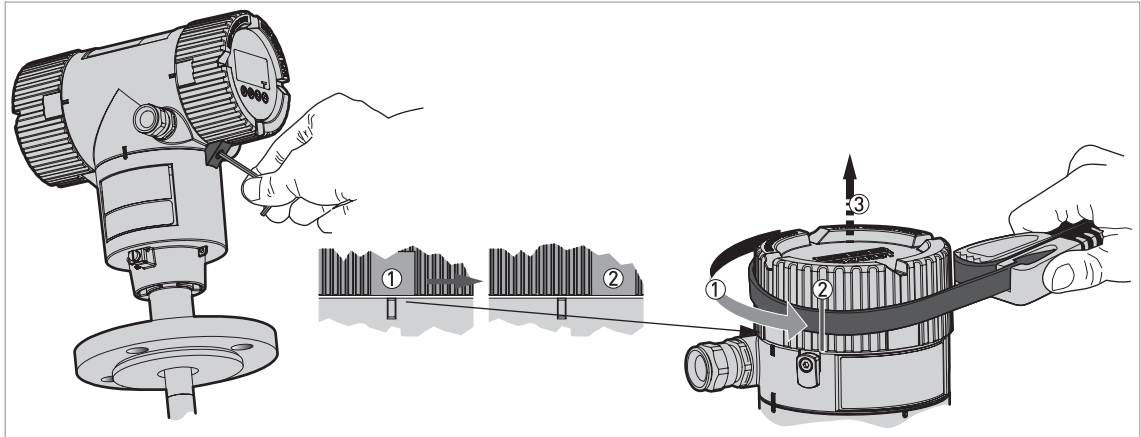

Figure 4-2: How to open the terminal compartment cover



- Loosen the lock screw with a 2.5 mm Allen wrench.
- Turn the cover counterclockwise with a strap wrench.
- Remove the cover.

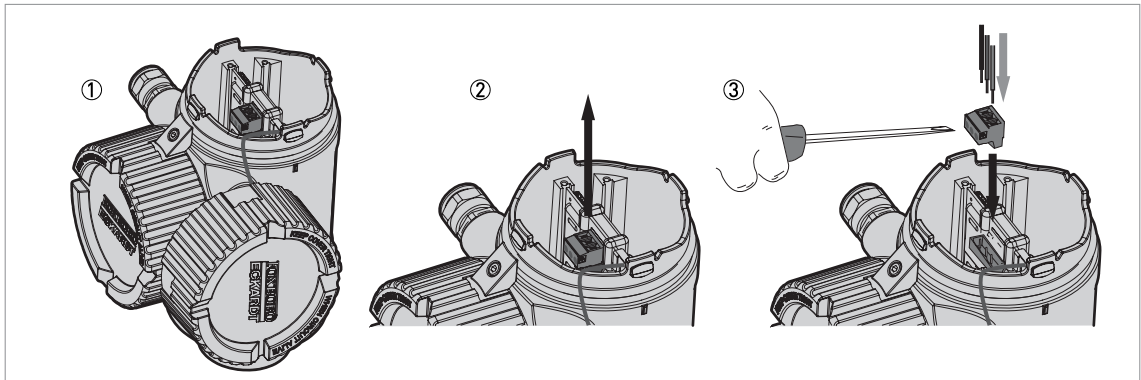

Figure 4-3: Procedure for electrical installation

Equipment needed:

- Small slotted tip screwdriver (not supplied)

**Procedure:**

- ① Do not disconnect the safety cord from the terminal compartment cover. Put the terminal compartment cover adjacent to the housing.
- ② Remove the connector from the circuit board.
- ③ Connect the electrical wires to the connector. Attach the connector to the circuit board. Tighten the cable entry glands.

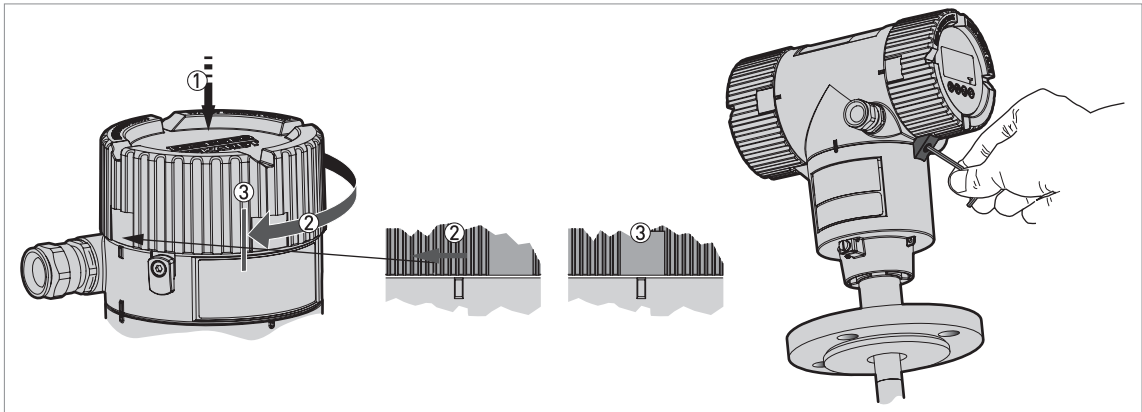

Figure 4-4: How to close the terminal compartment cover



- Put the cover on the housing and push it down.
- Turn the cover clockwise until it is fully engaged.
- Tighten the lock screw.

4.2.2 Remote version

Terminals for electrical installation

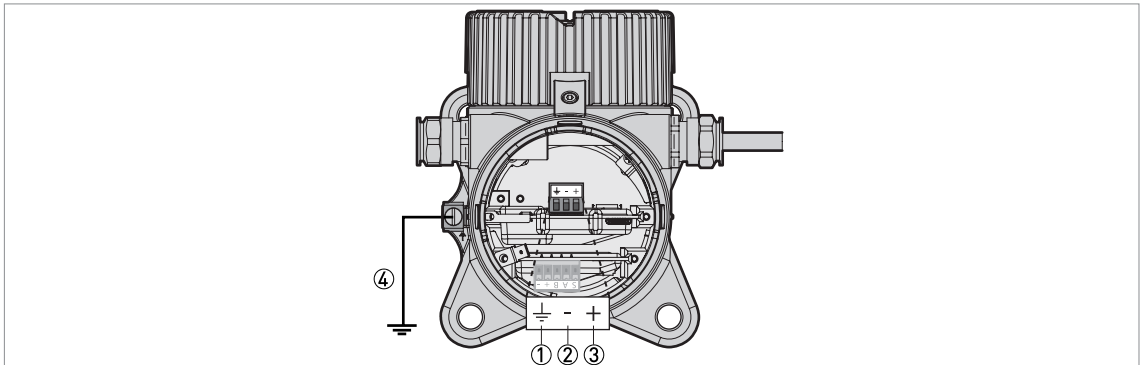

Figure 4-5: Terminals for electrical installation

- ① Grounding terminal in the housing (if the electrical cable is shielded)
- ② Current output -
- ③ Current output +
- ④ Location of the external grounding terminal (on the wall support)



INFORMATION!

Electrical power to the output terminal energizes the device. The output terminal is also used for HART® communication.



CAUTION!

- Use the applicable electrical cables with the cable glands.
- Make sure that the power supply does not have a current more than 5 A or that there is 5 A-rated fuse in the electrical circuit that energizes the device.
- Make sure that the polarity of the power supply is correct. If the polarity is incorrect, you will not cause damage to the device but the device will not operate.

For more electrical installation data, refer to *Compact version* on page 40.

4.3 Remote device data

4.3.1 Requirements for signal cables supplied by the customer



DANGER!

An Ex-approved signal cable is supplied by the manufacturer with devices for hazardous locations. Use of this signal cable is mandatory.

Non-Ex devices only: The signal cable is an option for non-Ex devices. If the signal cable is not supplied by the device manufacturer, the cable must have properties that follow:

Basic properties

- Twisted cable 2 by 2, shielded or screened. For example, multicore cable — reference MCD 5123 — from Cabletec ICS/JP Electronics.

Maximum length of the signal cable

- 100 m / 328 ft

Temperature

- Use electrical cable with the applicable temperature rating for the operating conditions.
- Ambient temperature range: -40...+80°C / -40...+175°F
- We recommend that the cable agrees with UL 94V-0.

Dimensions of the insulated conductors

- Min.-max. cross-sectional area of the conductors: 4x0.326...4x2.5 mm² (22....14 AWG), shielded cable
- Use the applicable cable for the cable glands (Ø6....10 mm / 0.24...0.39").
- Use the applicable cable glands for the cable entry openings in the housing.

Electrical characteristics

- Test voltage: Insulated conductor / shield (screen) ≥ 500 VAC
- Line resistance: < 55 Ω/km
- The cable must agree with EN 60811 (Low Voltage Directive) or equivalent national regulations.

4.3.2 How to prepare a signal cable supplied by the customer

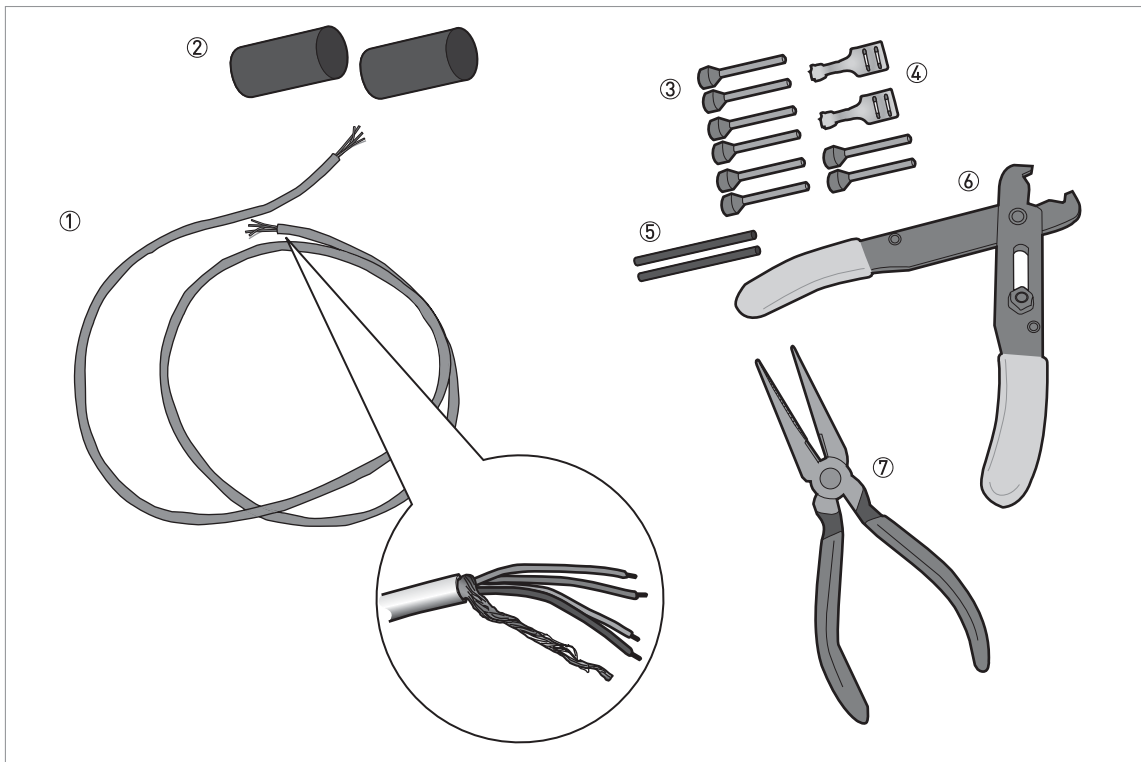

Figure 4-6: Equipment needed to prepare the signal cable

- ① Signal cable (supplied on request)
- ② 2 heat-shrinkable sleeves for the PVC jacket (not supplied)
- ③ 8 ferrules for the end of the conductors (not supplied)
- ④ 2 Faston connectors for the shield wires
- ⑤ Shield wire insulation, 2 sleeves
- ⑥ Wire stripper (not supplied)
- ⑦ Crimping pliers (not supplied)

**INFORMATION!**

- The Faston connector for the stranded drain wire must agree with DIN 46 228: E 1.5-8
- The wire end ferrules for the twisted pair of conductors must agree with DIN 46 228: E 0.5-8

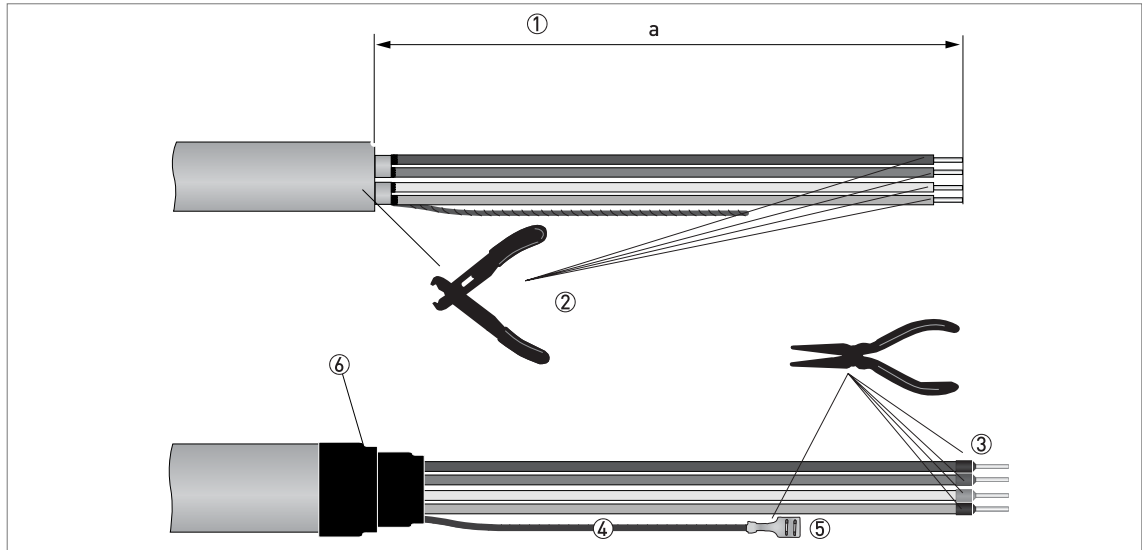

Figure 4-7: How to prepare the signal cable



- ① Remove the PVC jacket from the wire to dimension "a". $a = 50 \text{ mm} / 2''$.
- ② Remove the insulation from the wire. Obey national regulations for electrical wiring.
- ③ Crimp the wire end ferrules on the conductors.
- ④ Install shield wire insulation on the 2 ends of the shield wire.
- ⑤ Crimp the Faston connectors on the 2 ends of the shield wire.
- ⑥ Install a heat-shrinkable sleeve on the PVC jacket.

4.3.3 How to connect the signal cable to the device



DANGER!

Cables may only be connected when the power is switched off.



DANGER!

The device must be grounded in accordance with regulations in order to protect personnel against electric shocks.



DANGER!

For devices used in hazardous areas, additional safety notes apply; please refer to the Ex documentation.



WARNING!

Observe without fail the local occupational health and safety regulations. Any work done on the electrical components of the measuring device may only be carried out by properly trained specialists.

Equipment needed

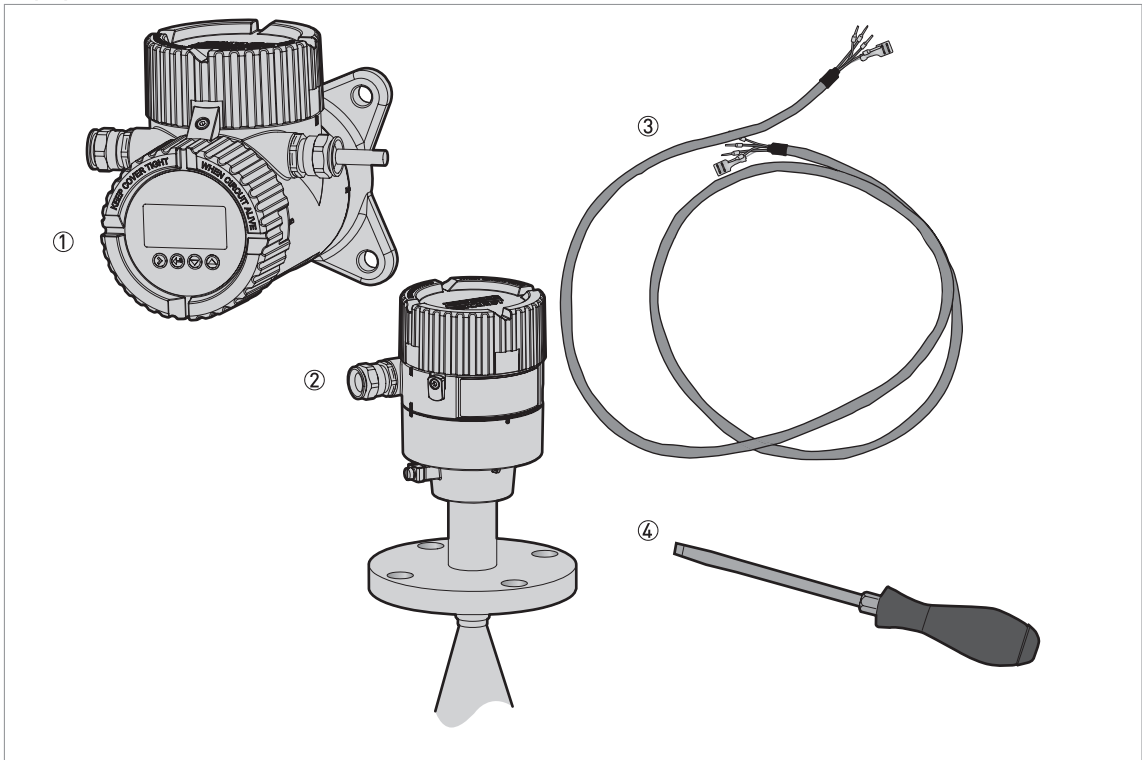

Figure 4-8: Equipment needed to prepare the signal cable

- ① Remote converter
- ② Antenna housing
- ③ Signal cable (supplied on request for non-Ex devices) - for more data, refer to *How to prepare a signal cable supplied by the customer* on page 44
- ④ Small slotted-tip screwdriver (not supplied)

Connections between the remote converter and the probe housing

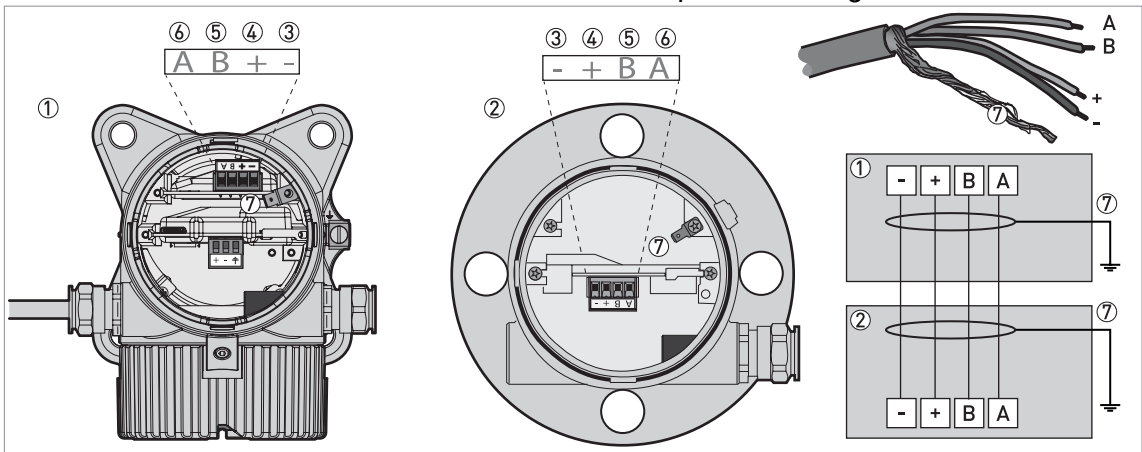

Figure 4-9: Connections between the remote converter and the probe housing

- ① Remote converter
- ② Probe housing
- ③ Power supply: voltage in -
- ④ Power supply: voltage in +
- ⑤ Signal cable B
- ⑥ Signal cable A
- ⑦ Shielding wire (attached to Faston connectors in the housings of the remote converter and the probe housing)

How to connect the signal cable to the remote converter

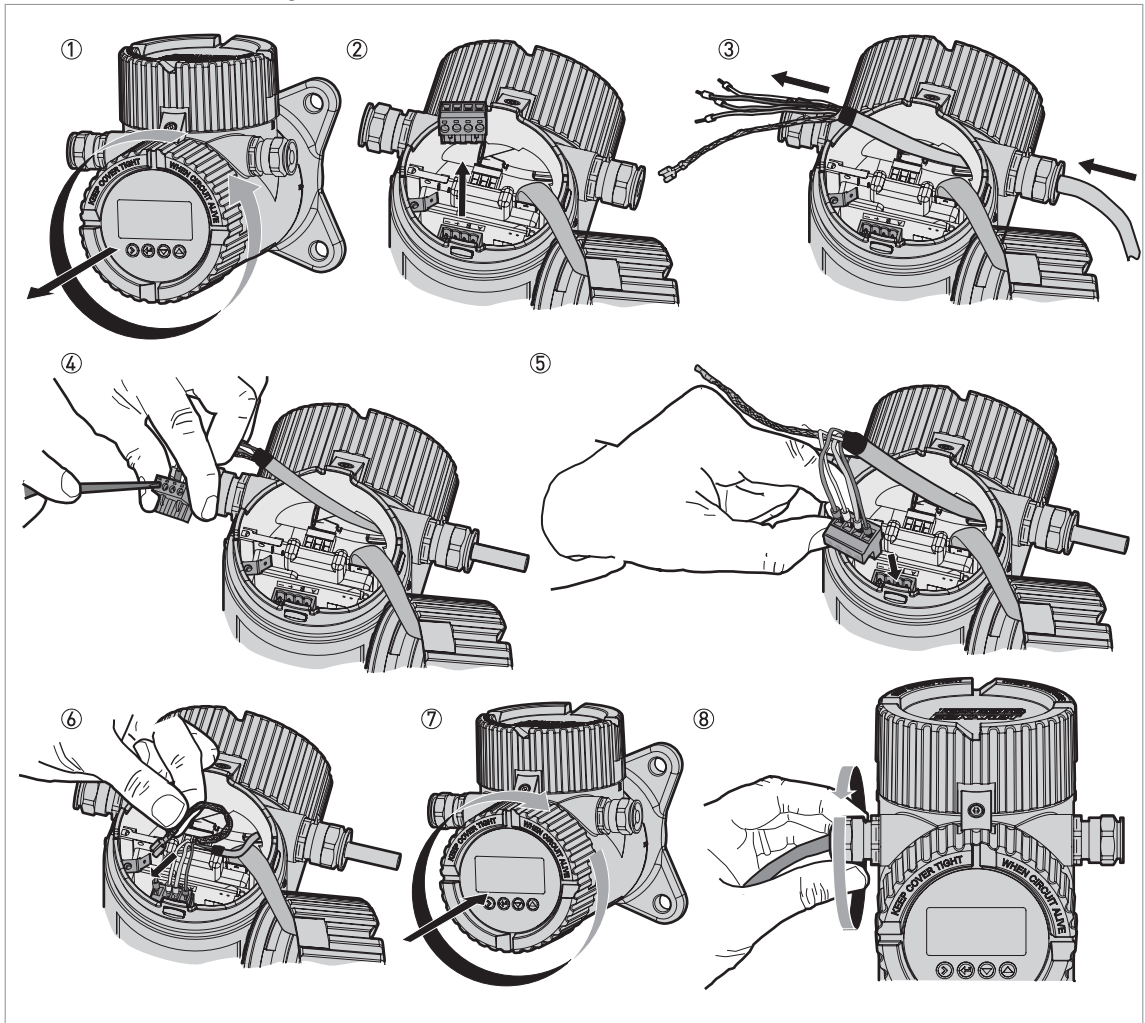

Figure 4-10: How to connect the signal cable to the remote converter

**CAUTION!**

Bending radius of the signal cable: ≥ 50 mm / 2"



- ① Remove the terminal compartment cover.
- ② Remove the 4-pin connector.
- ③ Put the signal cable into the opening of the cable gland.
- ④ Put the electrical wires in the connector terminals. Tighten the terminal screws with a small slot-tipped screwdriver. Make sure that the electrical wires agree with the terminals. For more data, refer to the electrical schema in this section.
- ⑤ Put the connector into the 4-pin socket.
- ⑥ Attach the Faston connector (drain wire).
- ⑦ Attach the terminal compartment cover.
- ⑧ Tighten the cable gland. Make sure that the remote converter is correctly sealed.

How to connect the signal cable to the antenna electronics

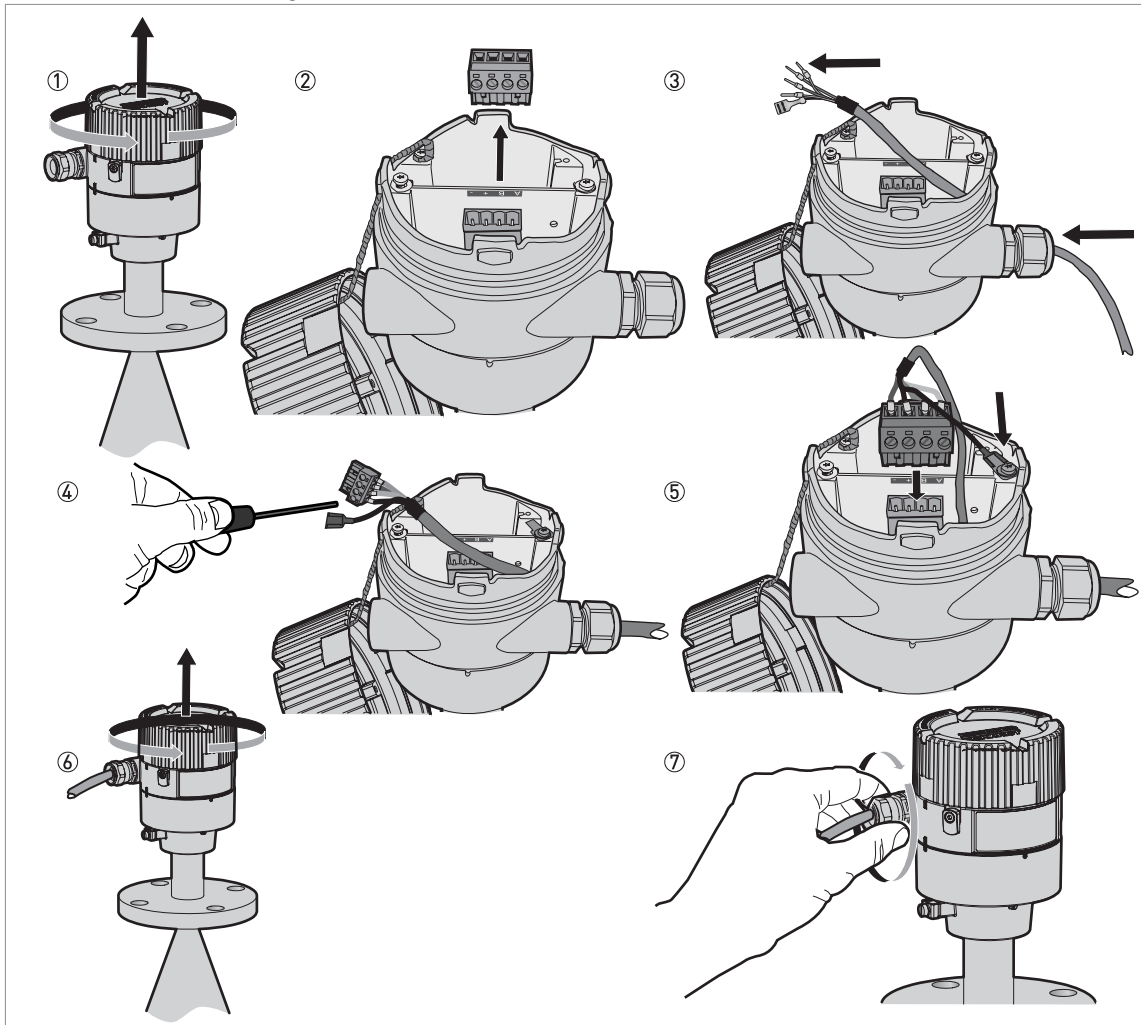

Figure 4-11: How to connect the signal cable to the antenna electronics

**CAUTION!**

Bending radius of the signal cable: ≥ 50 mm / 2"



- ① Remove the terminal compartment cover.
- ② Remove the 4-pin connector.
- ③ Put the signal cable into the opening of the cable gland.
- ④ Put the electrical wires in the connector terminals. Tighten the terminal screws with a small slot-tipped screwdriver. Make sure that the electrical wires agree with the terminals. For more data, refer to the electrical schema in this section.
- ⑤ Put the connector into the 4-pin socket. Attach the Faston connector (drain wire).
- ⑥ Attach the terminal compartment cover.
- ⑦ Tighten the cable gland. Make sure that the probe housing is correctly sealed.

4.4 Electrical connection for current output

4.4.1 Non-Ex devices

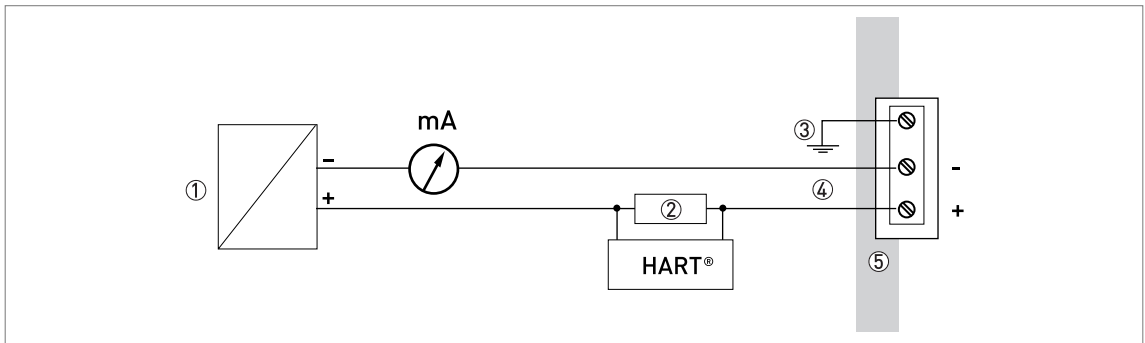

Figure 4-12: Electrical connections for non-Ex devices

- ① Power supply
- ② Resistor for HART® communication
- ③ Optional connection to the grounding terminal
- ④ Output: 12...30 VDC for an output of 22 mA at the terminal
- ⑤ Device

4.4.2 Devices for hazardous locations



DANGER!

For electrical data for device operation in hazardous locations, refer to the related certificates of compliance and supplementary instructions (ATEX, cFMus, ...). This documentation can be downloaded from our website.

4.5 Protection category



INFORMATION!

The device fulfills all requirements per protection category IP 66/67. It also fulfills all requirements per NEMA type 4X (housing) and type 6P (antenna).



DANGER!

Make sure that the cable gland is watertight.

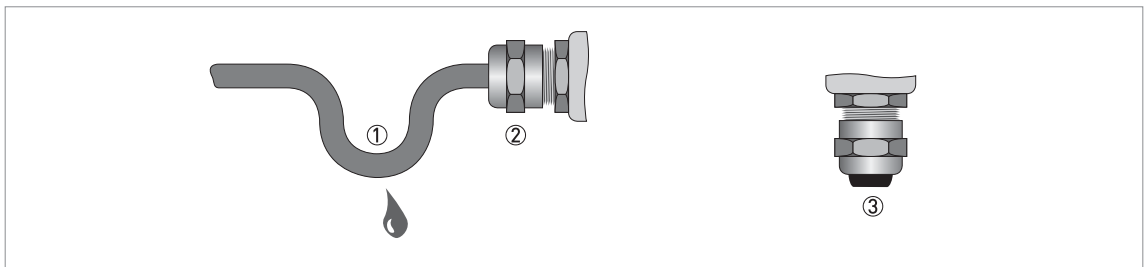

Figure 4-13: How to make the installation agree with protection category IP 67



- Make sure that the gaskets are not damaged.
- Make sure that the electrical cables are not damaged.
- Make sure that the electrical cables agree with the national electrical code.
- The cables are in a loop in front of the device ① so water does not go into the housing.
- Tighten the cable feedthroughs ②.

- Close unused cable feedthroughs with dummy plugs ③.

The diameter of the outer sheath of the electrical cable and must be 6...10 mm or 0.2...0.39".

4.6 Networks

4.6.1 General information

The device uses the HART[®] communication protocol. This protocol agrees with the HART[®] Communication Foundation standard. The device can be connected point-to-point. It can also operate in a multi-drop network of up to 15 devices.

The device output is factory-set to communicate point-to-point. To change the communication mode from **point-to-point** to **multi-drop**, refer to *HART[®] network configuration* on page 75.

4.6.2 Point-to-point connection

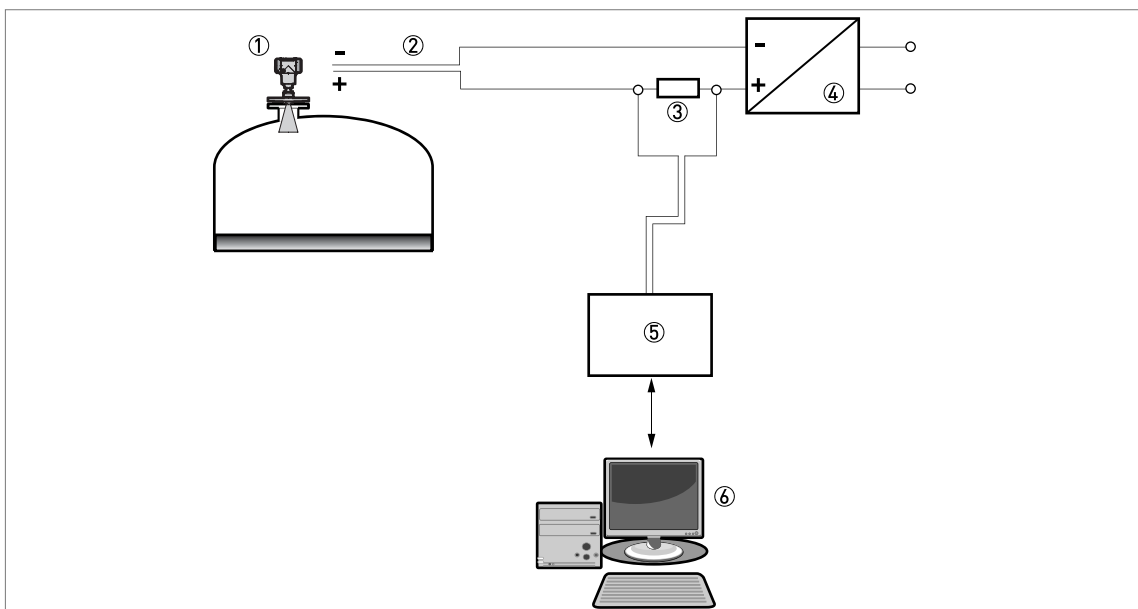

Figure 4-14: Point-to-point connection (non-Ex)

- ① Address of the device (0 for point-to-point connection)
- ② 4...20 mA + HART[®]
- ③ Resistor for HART[®] communication
- ④ Power supply
- ⑤ HART[®] converter
- ⑥ HART[®] communication software

4.6.3 Multi-drop networks

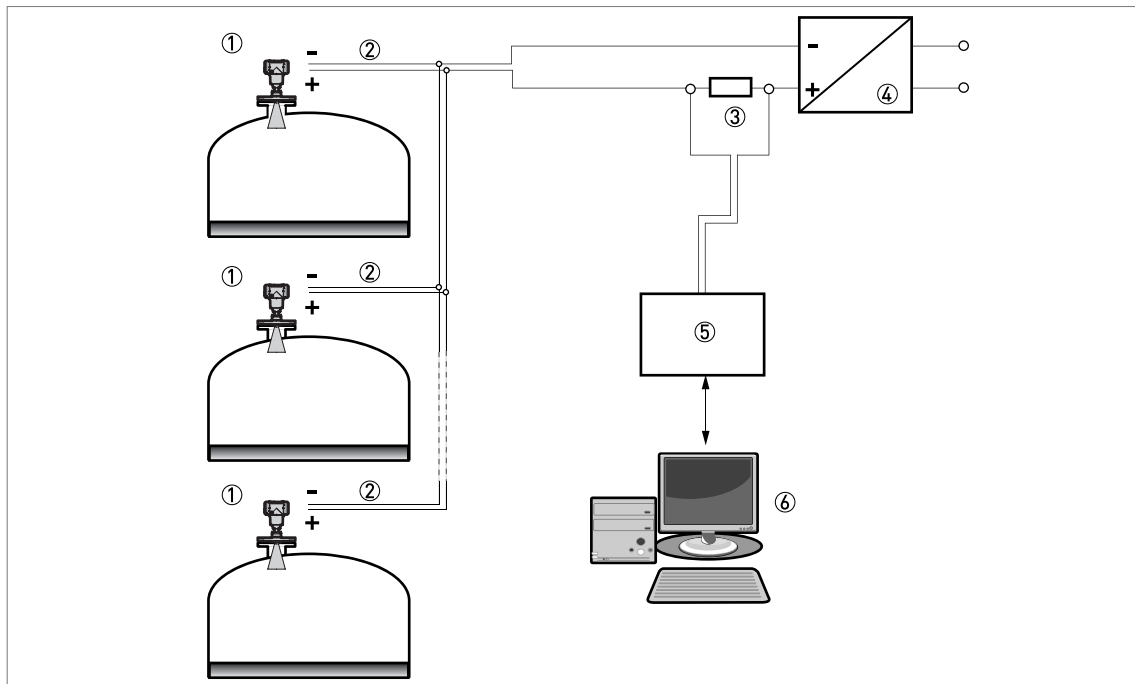

Figure 4-15: Multi-drop network (non-Ex)

- ① Address of the device (each device must have a different address in multidrop networks)
- ② 4 mA + HART®
- ③ Resistor for HART® communication
- ④ Power supply
- ⑤ HART® converter
- ⑥ HART® communication software

4.6.4 Fieldbus networks

**INFORMATION!**

Fieldbus options are available for the compact version of the device.

For more data, refer to the supplementary instructions for FOUNDATION™ fieldbus and PROFIBUS PA.

FOUNDATION™ fieldbus network (non-Ex)

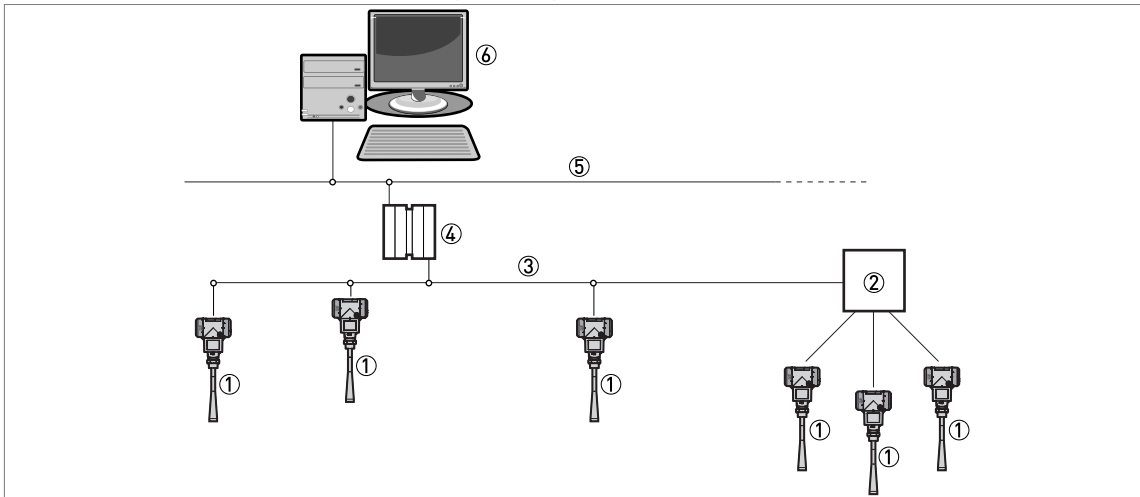

Figure 4-16: FOUNDATION™ fieldbus network (non-Ex)

- ① Field device
- ② Junction box
- ③ H1 network
- ④ H1/HSE converter
- ⑤ High Speed Ethernet (HSE)
- ⑥ Workstation

PROFIBUS PA/DP network (non-Ex)

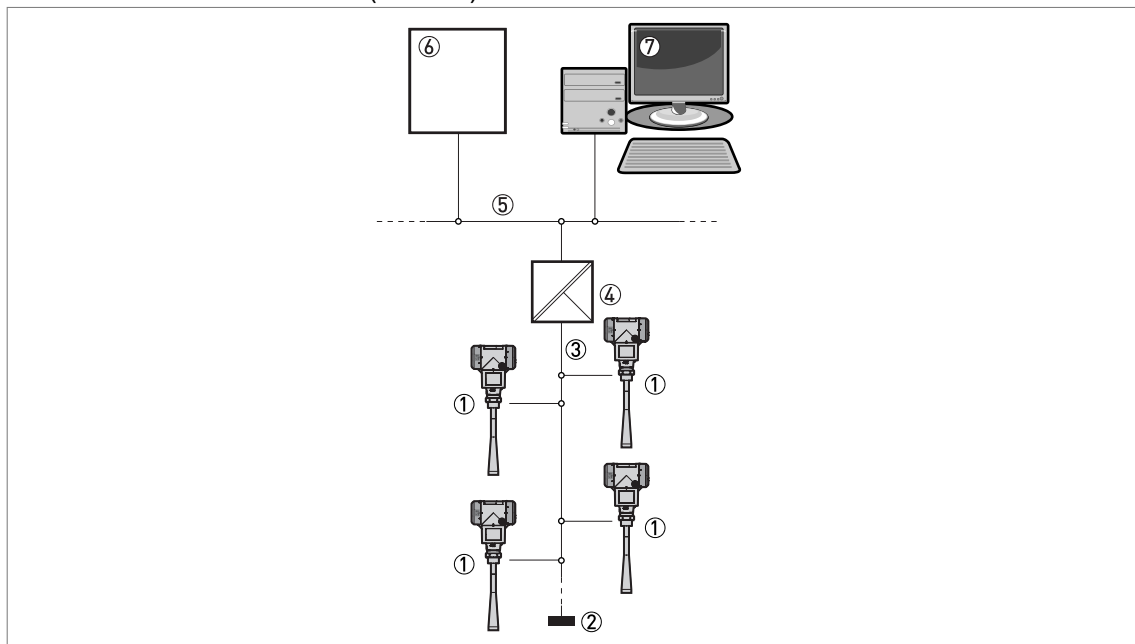

Figure 4-17: PROFIBUS PA/DP network (non-Ex)

- ① Field device
- ② Bus termination
- ③ PROFIBUS PA bus segment
- ④ Segment coupler (PA/DP link)
- ⑤ PROFIBUS DP bus line
- ⑥ Control system (PLC / Class 1 master device)
- ⑦ Engineering or operator workstation (Control tool / Class 2 master device)

5 Start-up

5.1 How to start the device

5.1.1 Start-up checklist

Check these points before you energize the device:

- Are all the wetted components (antenna, flange and gaskets) resistant to the product in the ?
- Does the information on the signal converter nameplate agree with the operating data?
- Did you correctly install the device on the ?
- Do the electrical connections agree with the national electrical codes? Use the applicable electrical cables with the cable glands.



DANGER!

Before you energize the device, make sure that the supply voltage and polarity are correct.



DANGER!

Make sure that the device and the installation agrees with the requirements of the Ex certificate of compliance.

5.1.2 How to start the device



- Connect the converter to the power supply.
- Energize the converter.
- ➔ **Devices with the LCD display option only:** After 10 seconds the screen will display "Starting up". After 20 seconds the screen will display the software version numbers. After 30 seconds the default screen will appear.
- The device will display readings.



INFORMATION!

This chapter and the start of the chapter that follows tells you what data is given on the device display in normal mode and how to change device settings in configuration mode. If you know about how this device operates, you can ignore this data. Continue with the quick setup procedure. For more data about this procedure.

5.2 Operating concept

You can read measurements and configure the device with:

- A digital display screen (optional).
- A connection to a system or PC with PACTware™. You can download the Device Type Manager (DTM) file from the website.
- A connection to a system or PC with AMS™. You can download the Device Description (DD) file from the website.
- A connection to a HART® Field Communicator. You can download the Device Description (DD) file from the website.

5.3 Digital display screen

5.3.1 Local display screen layout

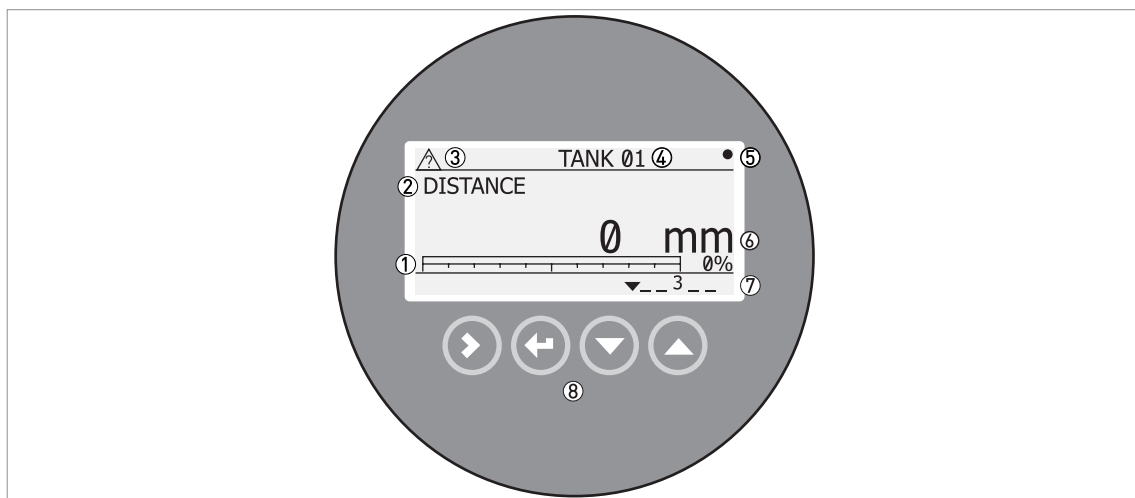

Figure 5-1: Local display screen layout in Normal mode

- ① Current output percentage (bar graph and text — only shown if the current output function is the same as the measurement on the screen in normal mode)
- ② Measurement type (in this example, distance)
- ③ Device status (NE 107 symbols)
- ④ Device tag name
- ⑤ Updated measurement data symbol (the symbol flashes each time the measurement data is updated)
- ⑥ Measurement value and units
- ⑦ Device status (markers)
- ⑧ Keypad buttons (refer to the table in the section that follows)

The current output percentage is only shown if the measurement type (refer to item ② in the illustration) is the same as the output function. The parameter is set in menu item 2.4.1 OUTPUT FUNC.). For example, if the output function is set to "Level" and the device shows "Level" measurements in normal mode, the bar graph and value is shown (refer to item ① in the illustration).



Figure 5-2: Local display screen layout in configuration mode

- ① Function name
- ② Configuration mode symbol
- ③ Menu number

5.3.2 Functions of keypad buttons

Keypad button	Function
[Right]	Normal mode: Enter Information menu (Enter Configuration mode)
	Configuration mode: Move cursor to the right
[Return / Escape]	Normal mode: Change units (m, cm, mm, in, ft)
	Configuration mode: Exit
[Down]	Normal mode: Change measurement type (distance, level, output (%), output (mA), conversion, ullage conversion, reflection) ①
	Configuration mode: Decrease value or change parameter
[Up]	Normal mode: Change measurement type (distance, level, output (%), output (mA), conversion, ullage conversion, reflection) ①
	Configuration mode: Increase value or change parameter

① If you have made a strapping table in menu item 2.8.1 INPUT TABLE for volume or mass measurement, "Conversion" and "Ullage Conv." will be shown in the list of measurement types

For data on keypad functions, refer to *Normal mode* on page 58.

5.4 Remote communication with PACTware™

PACTware™ displays measurement information clearly on a computer (PC) and lets you configure the device from a remote location. It is an Open Source, open configuration software for all field devices. It uses Field Device Tool (FDT) technology. FDT is a communication standard for sending information between the system and the field device. Field devices are easily integrated. Installation is supported by a user-friendly Wizard.

Install these software programs and equipment:

- Microsoft® .NET Framework version 1.1 or later.
- PACTware.
- HART® converter (USB, RS232...).
- The Device Type Manager for the device.

The software and installation instructions are given on the DVD-ROM supplied with the device.

You can also download the latest version of PACTware™ and the DTM from our internet site.

Refer also to the PACTware™ consortium site at <http://www.pactware.de>.

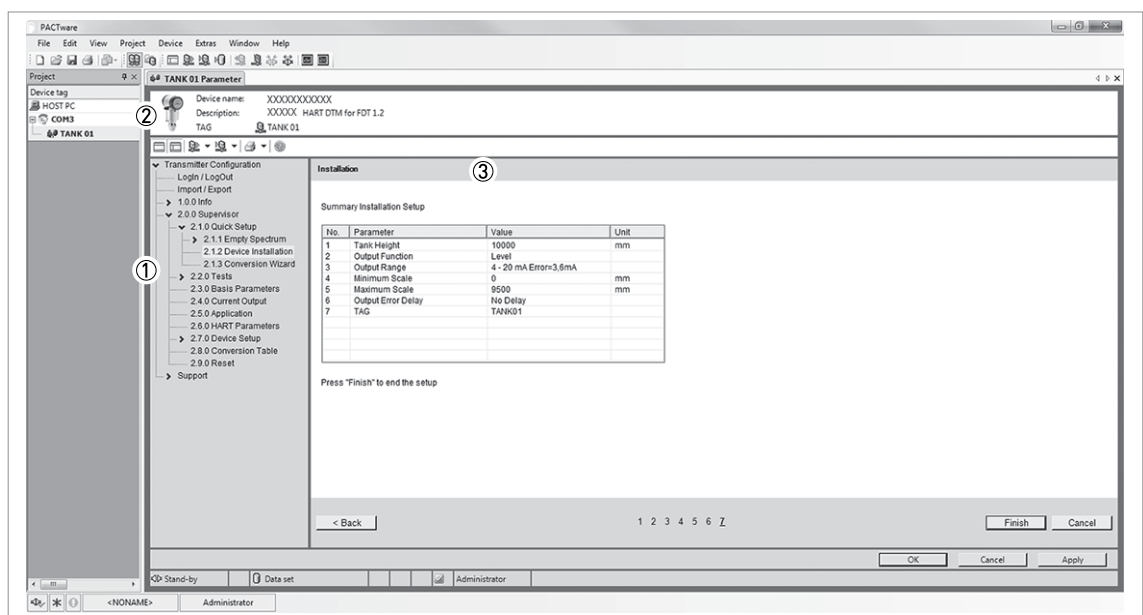

Figure 5-3: Screen from the PACTware™ user interface

- ① DTM menu
- ② Information for device identification
- ③ Configuration summary

5.5 Remote communication with the AMS™ Device Manager

The AMS™ Device Manager is an industrial Plant Asset Management (PAM) software tool. Its role is to:

- Store configuration information for each device.
- Support HART® and FOUNDATION™ fieldbus devices.
- Store and read process data.
- Store and read diagnostic status information.
- Help plan preventive maintenance to reduce a plant's downtime to a minimum.

The DD file can be downloaded from our website.

6 Operation

6.1 User modes

Normal mode	This mode displays measurement data. For more data, refer to <i>Normal mode</i> on page 58.
Configuration mode	Use this mode to view parameters, commission the device, create tables for volume or mass measurement, change critical values to measure in difficult process conditions. To get access to supervisor menu, refer to <i>Protection of the device settings</i> on page 75. For more data on menu items, refer to <i>Function description</i> on page 65.





6.2 Normal mode

This mode shows measurement data. Use the table that follows:

- for the selection of the measurement type (level, distance, percentage, conversion, reflection) and
- for the selection of the measurement units

Some measurement types will only be available if the device has the correct parameters entered in the configuration mode.

Keypad functions

Button	Description	Function	"Hot key" function
	Right	Enter configuration mode.	-
	Return / Escape	Change the measurement units.	-
	Down	Change the measurement type.	-
	Up	Change the measurement type.	Display language will change to English ①

① The display language will change when you push this button for 2 seconds. Push the button again and it will go back to the original language.

Measurement type definitions

Measurement type	Description	Available units
LEVEL	This is a display and an output function option. It is the height from the bottom of the tank to the surface of the liquid (Tank height - Distance).	m, cm, mm, in (inches), ft (feet)
DISTANCE	This is a display and an output function option. It is the distance from the face of the flange (or thread stop) to the surface of the liquid.	m, cm, mm, in (inches), ft (feet)
CONVERSION	This is a display and an output function option. It gives the volume or mass of the tank contents. This data is available if you prepare a volume or mass table in configuration mode. For data on how to prepare the conversion table, refer to <i>How to configure the device to measure volume or mass</i> on page 78. If the device is used with PACTware™ software, it can also show flow rate in a channel. 6 flow profiles are available in the menu: Parshall (ISO 9826), Venturi Rectangular (ISO 4359), Venturi Trapezoidal (ISO 4359), Venturi U (ISO 4359), V-Notch (ISO 1438) or Rectangular Notch (ISO 1438).	m3, L, gal (US gallons), ImpG (Imperial gallons), ft3, bbl (oil barrel), kg, t, Ston, Lton, m, cm, mm, in, ft, m3/h, ft3/h
ULLAGE CONV.	This is a display and an output function option. It gives the empty volume or remaining mass that can be put in the tank. This data is available if you prepare a volume or mass table in configuration mode. For data on how to prepare the conversion table, refer to <i>How to configure the device to measure volume or mass</i> on page 78.	m3, L, gal (US gallons), ImpG (Imperial gallons), ft3, bbl (oil barrel), kg, t, Ston, Lton, m, cm, mm, in, ft, m3/h, ft3/h
REFLECTION	This is a display and an output function option. It is the percentage of the emitted radar signal which makes a reflection on the surface of the liquid and is received by the device.	%
OUTPUT I (mA)	The current output of the device.	mA
OUTPUT I (%)	The percentage of the current output. 0% = 4 mA. 100% = 20 mA.	%

6.3 Configuration mode

6.3.1 General notes

Change the settings of your device in **Configuration** mode. Data about the menus is given on page 65. You can:

- Use the **1.0.0 INFORMATION** menu to read settings, device software versions and error records. For more data about the Information menu, refer to Table 1: Info.
- Use the **2.0.0 SUPERVISOR** menu to commission the device, to run diagnostic tests, set up a conversion table for volume, mass or flow rate measurement, change critical parameters for difficult process conditions, reset the device and change basic parameters (tank height etc.), output settings, HART Address etc. For more data about the Supervisor menu, refer to Table 2: Supervisor.



INFORMATION!

It is not possible to enter the 3.0.0 SERVICE and 4.0.0 MASTER menus. These menus are for factory calibration and approved personnel only.

6.3.2 How to get access to the commissioning menu



Do the steps that follow:

- Push the [>] button.
 - ➡ This shows the **Information** menu. The **Information** menu is read only and does not have password security.
- Push the [▲] button one time to scroll up to the **Supervisor** menu.
 - ➡ The screen shows the text "2.0.0 SUPERVISOR".
- Push the [>] button one time.
 - ➡ The screen shows a line. You must enter the password. Push the buttons under the display screen 6 times (in total and in a given order) to get access to Configuration mode.
- Type in the password. The factory-set password is [>], [←], [▼], [▲], [>] and [←].
 - ➡ The device shows the text "2.1.0 COMMISSIONING".
- Push [>]. Do the basic configuration of the device in the "Parameters" menu. For more data on the procedure, refer to *Quick Setup (Parameters)* on page 72. Push [←] at the end of each step of the procedure to continue to the next step.
- Push [▲] to go to menu item 2.1.2 EMP.SPEC.REC. Push [>] to start the empty spectrum recording procedure. For more data, refer to *Function description* on page 65, Table 2: Supervisor.



CAUTION!

SIL-approved devices: For data about critical device parameters for SIL approval, refer to the Safety Manual (SIL approval).



INFORMATION!

HOW TO SET THE SUPERVISOR PASSWORD TO "ON" OR "OFF"

The supervisor password is set to "on" by default. If it is necessary to set this function to "off", refer to Function description on page 65, Table 2: Supervisor menu, menu item PSWD YES/NO (2.7.4).



INFORMATION!

HOW TO CHANGE THE SUPERVISOR PASSWORD

You can change the password for the supervisor menu. For more data, refer to Function description on page 65, Table 2: Supervisor menu, menu item PASSWORD (2.7.5).

6.3.3 Keypad functions



Figure 6-1: Local display screen layout in configuration mode

- ① Function name
- ② Configuration mode symbol
- ③ Menu number

This is what you see when you are in Configuration mode. The functions of the buttons are given in the table that follows:

Functions of buttons for menu navigation

Button	Description	Function
	Right	<ul style="list-style-type: none"> • Go down to the sub-menu level (for example, from menu 1.0.0 to sub-menu 1.1.0). • Enter the menu item
	Enter / Esc (Escape)	<ul style="list-style-type: none"> • Go up to the menu level (for example, from sub-menu 1.1.0 to menu 1.0.0). • Go to Normal mode. If you changed settings in Configuration mode, you must save or cancel your new settings. For more data, refer to the end of this section.
	Down	<ul style="list-style-type: none"> • Scroll down the menu list (for example, from menu 2.0.0 to menu 1.0.0). • Scroll down the sub-menu list (for example, from sub-menu 2.2.0 to sub-menu 2.1.0).
	Up	<ul style="list-style-type: none"> • Scroll up the menu list (for example, from menu 1.0.0 to menu 2.0.0). • Scroll up the sub-menu list (for example, from sub-menu 2.1.0 to sub-menu 2.2.0).

Lists of parameters in menu items

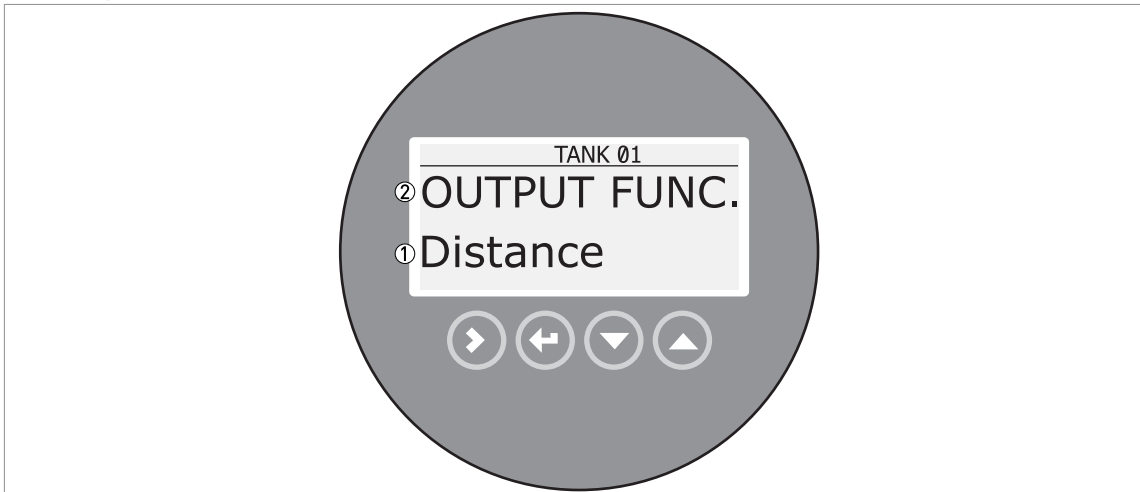





Figure 6-2: Lists of parameters in menu items

- ① Parameter
- ② Menu name

This is what you see when you select a menu item that has a list of parameters. The functions of the buttons are given in the table that follows:

Function of buttons in menu items that have a list of parameters

Button	Description	Function
	Right	n/a
	Enter / Esc (Escape)	Select the parameter and go back to the menu
	Down	Move down the list
	Up	Move up the list

Values in menu items

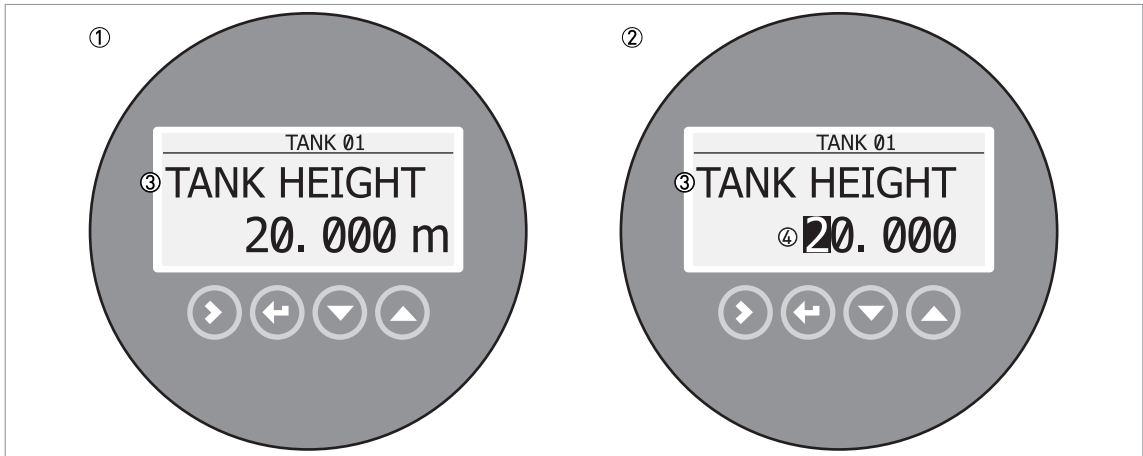

Figure 6-3: Values in menu items

- ① Menu item with values stored at this time (first screen)
- ② Push [➤] again to change the values. A cursor shows on the first digit.
- ③ Menu item name
- ④ Cursor on the selected digit

This is what you see when you select a menu item that has a value. The functions of the buttons are given in the table that follows:

Function of buttons in menu items that have values

Button	Description	Function
	Right	<ul style="list-style-type: none"> • Enter the menu item and see the value stored at this time. • Enter the menu item configuration level to change the value. • Move the cursor to the next digit on the right. If the cursor is on the last digit, push [➤] again to go back to the first digit.
	Enter / Esc (Escape)	Accept the value and go back to the sub-menu.
	Down	Decrease the digit value.
	Up	Increase the digit value.

How to save settings changed in the supervisor menu (menu 2.0.0)



- When you have changed parameters in all the necessary menu items, push [↵] to accept the new parameter.
- Push [↵] to go back to the "STORE" screen.
- The device will ask you to save or cancel your settings. Push [▲] or [▼] to select **STORE YES** or **STORE NO**. Push [↵] to accept or reject the new settings.
- ➡ The display goes back to Normal mode.

6.3.4 Menu overview

1.0.0 Info. (Information)

1.1.0	Ident. (Identification)
1.2.0	Output
1.3.0	History

2.0.0 Supervisor

2.1.0	Commissioning
2.2.0	Tests
2.3.0	Basic Parameters
2.4.0	Output I
2.5.0	Application
2.6.0	Communication
2.7.0	Display
2.8.0	Conversion
2.9.0	Config/Reset

3.0.0 Service

n/a	Password locked. Menus for factory calibration and qualified service personnel only.
-----	--

4.0.0 Master

n/a	Password locked. Menus for factory calibration and qualified service personnel only.
-----	--

6.3.5 Function description

1.0.0 Information (Info.) menu

Menu No.	Function	Function description	Selection list	Default
----------	----------	----------------------	----------------	---------

1.1.0 IDENT.

1.1.1	SERIAL NUM.	The device serial number.	Read only.	
1.1.2	CONV.FIRM.VER	The converter firmware version.	Read only.	
1.1.3	SEN.FIRM.VER	The sensor firmware version.	Read only.	
1.1.4	HMI.FIRM.VER	The HMI (device display screen) firmware version.	Read only.	

1.2.0 OUTPUT I

1.2.1	SUMMARY I	This shows the settings at this time for the output function (OUTPUT FUNC.), output range (RANGE I), 4 mA setting (SCALE 4mA), 20 mA setting (SCALE 20mA), and error delay (ERROR DELAY).	Read only.	
-------	-----------	---	------------	--

1.3.0 HISTORY

1.3.1	ERROR RECORD	A log of device errors. Push [➤] to read the errors. Push [▲] or [▼] to scroll up or down the list. Each error is identified by a code. Push [➤] again to show the number of incidents and the time since the last incident in days, hours, minutes and seconds. For more data about errors, refer to <i>Status and error messages</i> on page 81.	Read only.	
-------	--------------	--	------------	--

2.0.0 Supervisor menu

Menu No.	Function	Function description	Selection list	Default
----------	----------	----------------------	----------------	---------

2.1.0 COMMISSION.

2.1.1	PARAMETERS	This starts a quick set-up procedure applicable to most applications. The supervisor can give the tank height (TANK HEIGHT), type of tank (TANK TYPE), output function (OUTPUT FUNC.), current output range (RANGE I), 4 mA setting (SCALE 4mA), 20 mA setting (SCALE 20mA), error delay (ERROR DELAY) and tag name (TAG NAME).		
2.1.2	EMP.SPEC.REC	Fixed and moving objects in the tank cause interference signals. Put them through this filter to correctly measure the tank contents. A quick set-up procedure will go through the steps that follow (refer also to "How to make a filter to remove radar signal interference" on page 79):		
	①	Do you have a completely filled tank? If the tank is full, it is not possible to complete this procedure. The tank must be partially filled or empty.	Yes [>], No [▲]	
	②	Please, activate moving parts! We recommend that you switch on moving equipment to filter all interference signals.	OK [>]	
	③	Is your tank partially filled or empty? If the tank is partially filled, the device must include the tank contents when it filters the signal.	Partially [>], Empty [▲]	
	④	MEAS.DISTANCE If the tank is partially filled, type in a distance shorter than that between the flange and the tank contents.	min-max: 0...tank height (2.3.1)	distance to tank contents - 300 mm / 12"
	⑤	Emp.Spec.Type Use the average value for tanks which contain fixed objects only. Use the maximum value for tanks which contain many objects or moving objects.	Maximum, Average	?
	⑥	Recording in progress Reading in progress		
	⑦	Empty spectrum graph This shows a set of spectra (signals found in the tank). It also gives the amplitude and location of each signal. Push [>] to make a selection from the available spectra.		
	⑧	Do you want to save the empty spectrum data?	Yes [>], No [▲]	

2.2.0 TESTS

2.2.1	SET OUTPUT	This sets the current output to a test value [mA]. The output will change to the given value, independent of the measured value. The current output will go back to the measured value when the display goes back to the menu level.	3.5, 4, 6, 8, 10, 12, 14, 16, 18, 20 or 22 mA	3.5 mA
-------	------------	--	---	--------

Menu No.	Function	Function description	Selection list	Default
2.2.2	DIAGNOSTIC	<p>This starts the hardware test. Push [➤] many times to show:</p> <ul style="list-style-type: none"> • D1, the time of operation • T1, temperature of the electronic converter board • I1, loop current (internally measured value) • I2, load current (NOTE: this data is not available at this time) • V1, voltage 5.6 V. If the voltage is not 5.0<V1<5.7, speak to the supplier. • V2, voltage on capacitors. If the voltage is not 3.2<V2<3.4, speak to the supplier. • V3, voltage 3.3 V. If the voltage is not 3.2<V3<3.4, speak to the supplier. • C1, reset counter (watchdog timer). If C1>1, replace the signal converter. <p>If an NE 107 symbol and a status marker are shown, refer to <i>Device status (markers)</i> on page 81. If you push [➤] again, the display goes back to the menu level.</p>		

2.3.0 BASIC PARAM.

2.3.1	TANK HEIGHT	The distance from the flange face / thread stop of the tank connection down to the tank bottom. If the tank has a dish-shaped or conical bottom, the tank height is measured to a point on the tank bottom directly below the antenna. For more data about level measurement, refer to <i>Level measurement</i> on page 77. For more data about distance measurement, refer to <i>Distance measurement</i> on page 76.	min-max: 0...30 m / 0...98.4 ft	①
2.3.2	BLOCK. DIST.	Blocking distance. The distance from the flange to the top limit of the measuring range (a zone given by the user where it is not possible to measure). We recommend a blocking distance of 500 mm / 19.7" below the process connection. We also recommend that the limit of the measuring range is not less than the blocking distance. If it is possible that the tank contents will go above the blocking distance, set 2.5.5 OVERF. ENAB. to "Yes". If the distance is less than the blocking distance, the device continues to display the blocking distance.	min: 100 mm / 13.9" or 2.3.6 ANTENNA.EXT max: 2.3.1 TANK HEIGHT	500 mm / 19.7"
2.3.3	TIME CONST.	Using this function, the device processes several measurement readings to filter out disturbances. Increasing the time constant will smoothen the integrated readings, decreasing will roughen the readings. s=seconds.	min-max: 1.00...100.00 s	5.00 s
2.3.4	STILLWELL EN.	If the device is installed in a stilling well or has a Wave-Guide antenna, set this menu item to "Yes".	YES, NO	NO
2.3.5	STILLWELL D.	The inner diameter of the stilling well. If the device is installed in a stilling well or has a Wave-Guide antenna, enter the diameter. The device will use this data if you set 2.3.4 STILLWELL EN. to "Yes". This menu item is not shown if you set 2.3.4 STILLWELL EN. to "No".	min-max: 22...999 mm / 0.9...39.3"	①

Menu No.	Function	Function description	Selection list	Default
2.3.6	STILLWELL H.	The height of the stilling well. If the device is installed in a stilling well or has a Wave-Guide antenna, enter the height. The device will use this data if you set 2.3.4 STILLWELL EN. to "Yes". This menu item is not shown if you set 2.3.4 STILLWELL EN. to "No".	min: 500 mm / 19.7" max: 2.3.1 TANK HEIGHT	①
2.3.7	ANTENNA.EXT	Optional antenna extensions. These are attached between the flange and the antenna.	min: 0 mm / 0" or 2.3.6 ANTENNA.EXT max: 2000 mm / 78.7" or 2.3.1 TANK HEIGHT	①
2.3.8	ANTENNA.TYP	Type of antenna. For more data, refer to <i>Technical data</i> on page 91.	PP Horn, PTFE Horn, Metal. Horn, Wave Stick, Wave Guide	①
2.3.9	DIST.PIECE	Optional distance piece between the converter and the process connection. This is for high-temperature applications more than +150°C / +302°F. The distance piece is 120 mm / 4.7" long. For more data, refer to <i>Technical data</i> on page 91.	min: 0 mm / 0" max: TANK HEIGHT	①
2.3.10	TAG NAME	The device has an identification code (tag name). The supervisor can enter a maximum of 8 numbers or letters.		①

2.4.0 OUTPUT I

2.4.1	OUTPUT FUNC.	The output function. Select an output function to scale the current values in relation to a given point (usually the device process connection or the tank bottom). The output current value is shown on a bar graph in normal mode if the measurement type is the same as the output function. Conversion parameters are shown (Conversion, Ullage conversion) if there is level-volume, level-mass or level-flow rate data in 2.8.1 INPUT TABLE.	Distance, Level, Conversion, Ullage conversion, Reflection	①
2.4.2	RANGE I	This menu item sets the limits of the output current range to 1 of the 2 available options: standard limits (4...20 mA) or NAMUR NE 43-compliant limits (3.8...20.5 mA). It also tells the device what to do if an error occurs. If you set RANGE I to 4-20/22E and an error occurs (e.g. the tank is too full, ...), the device output current will change to an error value of 22 mA. If you set RANGE I to 4-20 and the device senses a measurement error, the value will stop at the last correct measurement.	4-20, 4-20/22E, 4-20/3.6E, 3.8-20.5/22E, 3.8-20.5/3.6E	4-20/3.6E
2.4.3	SCALE 4mA	This gives a measurement value to 4 mA.	min.-max: ②	①
2.4.4	SCALE 20mA	This gives a measurement value to 20 mA.	min.-max: ②	①
2.4.5	ERROR DELAY	The time after which the current output changes to an error value. The error value shows that there is a measurement error. mn=minutes and s=seconds.	0 s, 10 s, 20 s, 30 s, 1 mn, 2 mn, 5 mn, 15 mn	0 s

2.5.0 APPLICATION

2.5.1	TANK TYPE	The conditions in which the device is used. If the surface of the product is flat, select "Storage". If the surface of the product is disturbed, select "Process". If the surface of the product is agitated with vortices and foam, select "Agitator".	Storage, Process, Agitator	Process
-------	-----------	---	----------------------------	---------

Menu No.	Function	Function description	Selection list	Default
2.5.2	TRACKING VEL.	Maximum tracking velocity. This value must agree with the maximum rate of change of the level of the liquid in the tank.	min-max: 0.1...10.0 m/min	0.5 m/min
2.5.3	Er PRODUCT	For measurement in TBF mode only. The device automatically calculates the level based on the product ϵ_r . If you select "TBF Partial" or "TBF Full" in menu item 2.5.4 MEASUR.MODE, you can change the ϵ_r value manually to adjust readings.	min-max: 1.100 to 10.000	2.000
2.5.4	MEASUR.MODE	The device uses the dielectric constant (ϵ_r) of the tank contents to monitor level. In direct mode (if the dielectric constant is high), the level signal is a reflection on the surface of the tank contents. If the dielectric constant is low, the device uses TBF mode. The device in TBF mode uses the radar reflection on the bottom of the tank (the signal goes through the tank contents). The tank must have a flat bottom for the device to operate correctly in TBF mode. This menu item is set by default to "Direct" for tank contents with an $\epsilon_r > 1.8$. If ϵ_r is very low (< 1.6), use "TBF Full". If ϵ_r is low ($\epsilon_r = 1.5...1.7$), use "TBF Partial" mode. "TBF Partial" is an automatic mode that lets the device make a selection between "Direct mode" and "TBF" mode. If you use "TBF Full" or "TBF Partial", enter the dielectric constant in menu item 2.5.3 Er PRODUCT. Refer also to "Measuring principle" on page 91.	Direct, TBF Partial, TBF Full	Direct
2.5.5	OVERF. ENAB.	If this function is in operation, the device will monitor the level even if it is in the blocking distance. The reading shown on the display stays fixed at the blocking distance if the level is higher than the blocking distance. The output will show that the tank is full. An error is recorded by default. If this function is not in operation, the device looks for the largest signal between the process connection and the tank bottom.	YES, NO	NO
2.5.6	MULT.REF.EN.	Multiple reflections will cause the device to display smaller level readings. Objects in the tank, sharp corners, installation of the device on a large nozzle or at the centre of a dome roof, and low dielectric products ($\epsilon_r = 1.8...5$) can cause multiple reflections. A very calm surface or a tank with a small convex or flat roof can also cause multiple reflections. If this function is in operation, the device looks for the first signal peak below the process connection. This signal peak is then used to measure the level of the tank contents. If this function is not in operation, the device looks for the largest signal below the process connection.	YES, NO	NO
2.5.7	EMP.SPEC.EN.	The supervisor can start or stop the empty spectrum filter.	YES, NO	NO

2.6.0 COMMUNICAT.

2.6.1	ADDRESS	Any HART® address greater than 0 will activate HART® multidrop mode. The current output stays constant at 4 mA.	min.-max: 0...63	0
-------	---------	---	------------------	---

Menu No.	Function	Function description	Selection list	Default
----------	----------	----------------------	----------------	---------

2.7.0 DISPLAY

2.7.1	LANGUAGE	Data can be shown in any of the languages stored in the device.	9 languages are available in 3 packs: (1) English, French, German and Italian; (2) English, French, Spanish and Portuguese; (3) English, Chinese (Mandarin), Japanese and Russian	③
2.7.2	LENGTH UNIT	The length unit shown in normal mode.	m, cm, mm, in (inches), ft (feet)	m
2.7.3	CONV UNIT	Conversion unit. The length, volume, mass or flow rate conversion unit for the conversion table and shown in normal mode.	m3, L, gal (US gallons), ImpG (Imperial gallons), ft3, bbl (oil barrel), kg, t, Ston, Lton, m, cm, mm, in, ft, m3/h, ft3/h	L
2.7.4	PSWD YES/NO	If it is necessary to protect your settings in the supervisor menu with a password, set this menu item to YES .	YES, NO	YES
2.7.5	PASSWORD	This changes the password for the supervisor menu. Push the buttons up to 6 times in any order. This will be the new password. To confirm the change, enter the new password a second time. For more data, refer to <i>Protection of the device settings</i> on page 75.		[>], [←], [▼], [▲], [>] and [←]
2.7.6	CONTRAST	The contrast control for the display screen. You can select a shade of grey between light grey (level 20) and black (level 54).	min.-max: 20...54	36

2.8.0 CONV. TABLE

2.8.1	INPUT TABLE	The device uses a conversion table (strapping table) to convert measurements to volume, mass and flow rate readings. The readings are shown in normal mode. Give the number of entries on the table (min. 2; max. 30). Select an entry (01...30) and enter the level and the related volume / mass / flow rate value for that entry. Push [←] to confirm the entry values. Continue the procedure until the device has data for all the entries. For more data, refer to <i>How to configure the device to measure volume or mass</i> on page 78.	min. 2 entries max. 30 entries (level / volume, mass or flow rate)	0 entries
2.8.2	DELETE TABLE	This menu item erases the data in the conversion table.	YES, NO	NO

2.9.0 CONFIG/RESET

2.9.1	SAVE	This menu item is not available.	YES, NO	NO
2.9.2	RECALL	This menu item is not available.	YES, NO	NO
2.9.3	RESTART	This menu item starts the device again.	YES, NO	NO
2.9.4	RESET FACT.	If you set this menu item to "YES", the device goes back to its initial settings (set by the manufacturer in the factory).	YES, NO	NO

① This value is given in the customer order data

② Units and range depend on the output function, length unit and volume unit selected

③ If the device has the LCD display option, this depends on data given in the customer order

3. Service menu

Menu No.	Function	Function description	Selection list	Default
3.0.0	SERVICE	Advanced settings. The settings in this menu are protected with a password. Only approved personnel can change the parameters in this menu. For more data, contact your local sales office.		

4. Master menu



Menu No.	Function	Function description	Selection list	Default
4.0.0	MASTER	Factory settings. The settings in this menu are protected with a password. Only approved personnel can change the parameters in this menu. For more data, contact your local sales office.		



6.4 Further information on device configuration

6.4.1 Quick Setup (Parameters)

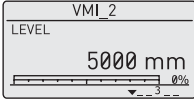
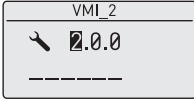
Use this procedure to change the tank height, tank type, output function, output range and give the top and bottom measuring limits. « xx » in the illustrations shows that you can change the value or the parameter. Push the keypad buttons in the correct sequence:

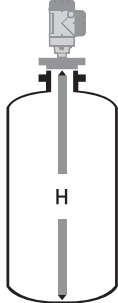
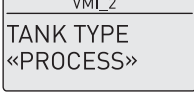
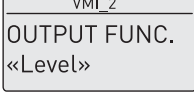
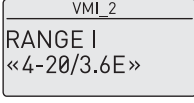
Procedure

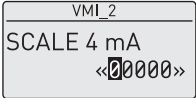
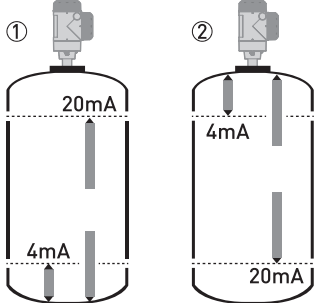
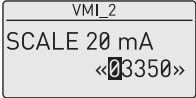
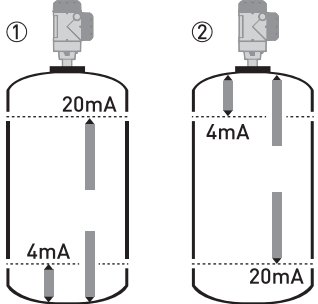
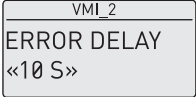

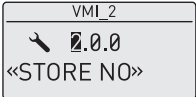
Screen	Steps	Description
	<ul style="list-style-type: none"> [>], [▲] and [>]. 	Default screen. Enter configuration mode (2.0.0 SUPERVISOR).
	<ul style="list-style-type: none"> [>], [←], [▼], [▲], [>] and [←]. 	Enter the password (the default password is shown). If it is necessary to change the password, refer to <i>Function description</i> on page 65, menu item 2.7.5 PASSWORD.
	<ul style="list-style-type: none"> 2 x [>] 	Push this button to start the quick set-up procedure.
	<ul style="list-style-type: none"> [>] to change the tank height (H). [>] to change the position of the cursor. [▼] to decrease the value or [▲] to increase the value. [←] to confirm. 	<p>The distance from the flange face / thread stop of the tank connection down to the tank bottom. If the tank has a dish-shaped or conical bottom, the tank height is measured to a point on the tank bottom directly below the antenna.</p> 
	<ul style="list-style-type: none"> [▲] or [▼] for the selection of the conditions in which the device is used (Storage, Process, Agitator). [←] to confirm. 	If the surface of the product is flat, select "Storage". If the surface of the product is disturbed, select "Process". If the surface of the product is agitated with vortexes and foam, select "Agitator".
	<ul style="list-style-type: none"> [▲] or [▼] for the selection of the measurement name (Distance, Level, Conversion, Ullage Conv. or Reflection). [←] to confirm. 	The manufacturer sets the output function to "Level" before delivery. If it is necessary to measure volume, ullage volume, mass or ullage mass (Conversion or Ullage Conv.), refer to <i>How to configure the device to measure volume or mass</i> on page 78.
	<ul style="list-style-type: none"> [▲] or [▼] for the selection of the current output range (4-20 mA/3.6E, 4-20, 3.8-20.5/3.6E, etc.). [←] to confirm. 	

Screen	Steps	Description
	<ul style="list-style-type: none"> • [➤] to change Scale 4 mA. • [➤] to change the position of the cursor. • [▼] to decrease the value or [▲] to increase the value. • [←] to confirm. 	<p>Use this step to give the 4 mA output setting (0% limit) in the tank. Refer to the illustrations that follow. Illustration ① shows the settings for level. Illustration ② shows the settings for distance.</p> 
	<ul style="list-style-type: none"> • [➤] to change Scale 20 mA. • [➤] to change the position of the cursor. • [▼] to decrease the value or [▲] to increase the value. • [←] to confirm. 	<p>Use this step to give the 20 mA output setting (100% limit) in the tank. Refer to the illustrations that follow. Illustration ① shows the settings for level. Illustration ② shows the settings for distance.</p> 
	<ul style="list-style-type: none"> • [▲] or [▼] for the selection of the error delay (0 s, 10 s, 20 s, 30 s, 1 mn, 2 mn, 5 mn or 15 mn). • [←] to confirm. 	<p>The time after which the current output changes to an error value. The error value shows that there is a measurement error.</p>
	<ul style="list-style-type: none"> • [➤] to change the tag name. • [➤] to change the position of the cursor. • [▼] to decrease the alphanumeric value (A, B, ..., 1, 2, ...) or [▲] to increase the alphanumeric value. • [←] to confirm. 	<p>The device has an identification code (tag name). The supervisor can enter a maximum of 8 numbers or letters.</p>
	<ul style="list-style-type: none"> • 2 x [←] to confirm. • [▲] or [▼] for the selection of the save option (STORE NO or STORE YES). • [←] to confirm. 	<p>Set to STORE YES to save and use the data. Set to STORE NO to cancel the changes to the device settings.</p>

6.4.2 Test

Use this procedure to test the loop current. « xx » in the illustrations shows that you can change the value or the parameter. Push the keypad buttons in the correct sequence:

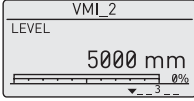
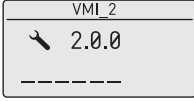
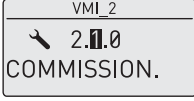
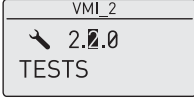
Procedure

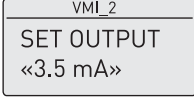
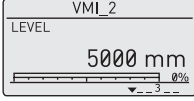
Screen	Step	Description
		Default screen.
	<ul style="list-style-type: none"> [>], [▲] and [>]. 	
	<ul style="list-style-type: none"> Enter the password: [>], [←], [▼], [▲], [>] and [←]. [←] 	
	<ul style="list-style-type: none"> [▲]. 	
	<ul style="list-style-type: none"> [>]. 	
	<ul style="list-style-type: none"> [>]. [▼] to decrease the value or [▲] to increase the value. [←] to confirm. 	This step sets the loop current value. Make a selection from 3.5, 4, 6, 8, 10, 12, 14, 16, 18, 20 or 22 mA.
	<ul style="list-style-type: none"> [←] 3 times to go back to the default screen. 	The loop current goes back to initial value. Default screen.

6.4.3 Protection of the device settings

The menu item PASSWORD (2.7.5) lets you change the supervisor menu password.



How to change the supervisor menu password

- After you enter the supervisor menu, push 6 × [▲], [➤] and 4 × [▲] to go to the menu item PASSWORD (2.7.5).
- Enter the new 6-character password (push the 4 buttons in any sequence).
- Enter the new 6-character password again.
- ➡ If the second entry is the same as the first, the device will go back to the sub-menu list (2.7). If the second entry is not the same as the first, the device will not go back to the sub-menu list. Push [←] to start the password sequence again and enter the new 6-character password 2 times.
- Push [←] to go back to the "STORE" screen.
- Push [▲] or [▼] to set the screen to **STORE YES** and push [←].
- ➡ The device will save the new password and go back to normal mode.



INFORMATION!

Make a note of the password and keep it in a safe place. If you lose the password, please contact your supplier.

How to set the supervisor password to "on" or "off"

The supervisor password is set to "on" by default. If it is necessary to set this function to "off", refer to *Function description* on page 65, Table 2: Supervisor menu, menu item PSWD YES/NO (2.7.4).

6.4.4 HART[®] network configuration



INFORMATION!

For more data, refer to Networks on page 50.

The device uses HART[®] communication to send information to HART[®]-compatible equipment. It can operate in either point-to-point or multidrop mode. The device will communicate in multidrop mode if you change the address.



CAUTION!

Make sure that the address for this device is different from others in the multidrop network.



How to change from point-to-point to multidrop mode

- Enter the supervisor menu.
- Push [➤], 5 × [▲] and [➤] to go to menu item ADDRESS (2.6.1).
- Push [➤] to change the value. Enter a value between 1 and and push [←] to confirm (refer to the caution before this procedure).
- Push [←] to go back to the "STORE" screen.
- Push [▲] or [▼] to set the screen to **STORE YES** and push [←].
- ➡ The output is set to multidrop mode. The current output is set to 4 mA. This value does not change in multidrop mode.



How to change from multidrop to point-to-point mode

- Enter the supervisor menu.
- Push [➤], 5 × [▲] and [➤] to go to menu item ADDRESS (2.6.1).
- Push [➤] to change the value. Enter the value 0 and push [←] to confirm.
- Push [←] to go back to the "STORE" screen.
- Push [▲] or [▼] to set the screen to **STORE YES** and push [←].
- ➡ The output is set to point-to-point mode. The current output changes to a range of 4...20 mA or 3.8...20.5 mA (this range is set in menu item RANGE I (2.4.2)).

6.4.5 Distance measurement

The device displays distance measurements when the output function is set to "Distance". Menu items related to distance measurement are:

- Output Function (2.4.1)
- Tank Height (2.3.1)
- Blocking Distance (2.3.2)



CAUTION!

If the distance for 4 mA is set in the blocking distance, the device will not be able to use the full current output range.

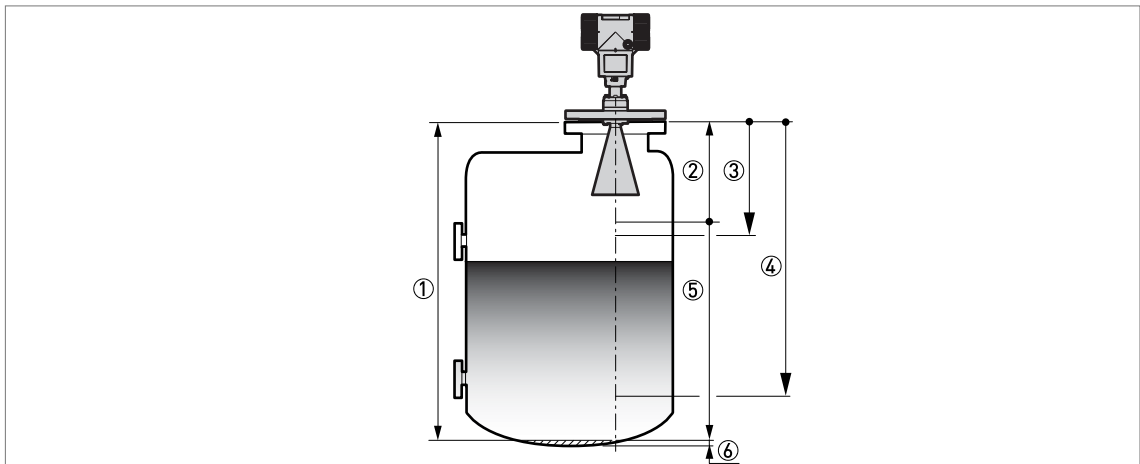

Figure 6-4: Distance measurement

- ① Tank Height (2.3.1)
- ② Blocking Distance (2.3.2)
- ③ 4 mA Setting (2.4.3)
- ④ 20 mA Setting (2.4.4)
- ⑤ Maximum effective measuring range
- ⑥ Non-measurement zone

For more data about the menu items, refer to *Function description* on page 65, table 2. Supervisor menu.

6.4.6 Level measurement

The device displays level measurements when the output function is set to "Level". Menu items related to level measurement are:

- Output Function (2.4.1)
- Tank Height (2.3.1)
- Blocking Distance (2.3.2)



CAUTION!

If the level for the 20 mA is set in the blocking distance, the device will not be able to use the full current output range.

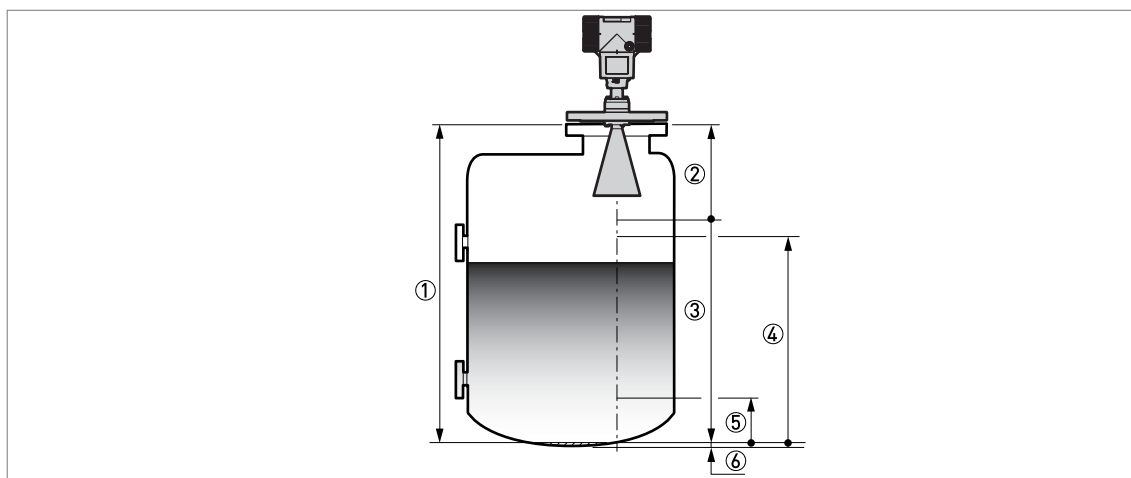

Figure 6-5: Level measurement

- ① Tank Height (2.3.1)
- ② Blocking Distance (2.3.2)
- ③ Maximum effective measuring range
- ④ 20 mA Setting (2.4.4)
- ⑤ 4 mA Setting (2.4.3)
- ⑥ Non-measurement zone

For more data about the menu items, refer to *Function description* on page 65, table 2: Supervisor menu.

6.4.7 How to configure the device to measure volume or mass

The device can be configured to measure volume or mass. You can set up a strapping table in the conversion table (2.8.0 CONV. TAB) sub-menu. Each entry is a pair of data (level - volume, level - mass or level - flow rate). The strapping table must have a minimum of 2 entries and a maximum of 30. The reference point for the table is the bottom of the tank (as given in menu item 2.3.1 TANK HEIGHT).



CAUTION!

Enter the data in numerical sequence (strapping table entry number 01, 02, ...).



How to prepare a strapping table.

- Enter the supervisor menu.
- Push [>], 6 × [▲], [>] and [▲] to go to 2.7.2 LENGTH UNIT.
- Push [▲] and [▼] to find the length unit that you will use in the table.
- Push [←] to go to the sub-menu level.
- Push [▲] to go to 2.7.3 CONV UNIT (conversion unit)
- Push [▲] and [▼] to find the conversion unit that you will use in the table.
- Push [←] to go to the sub-menu level and then [▲] and [>] to go to the menu item 2.8.1 INPUT TAB
- Push [>] to make the strapping table. Enter the table entry number (01).
- Enter the length value and push [←].
- Enter the conversion value and push [←].
- Push [>] to enter the subsequent table entry number (02, 03, ..., 30).
- Repeat the last 3 steps to complete the table.
- Push [←] to go back to the "STORE" screen.
- Push [▲] or [▼] to set the screen to **STORE YES** and push [←].
- ➡ The device will store the data for the strapping table and go back to normal mode.

The device will give more accurate volume readings if you give more conversion data in these areas:

- Surfaces with curves.
- Sudden changes in the cross section.

Refer also to the illustration that follows:

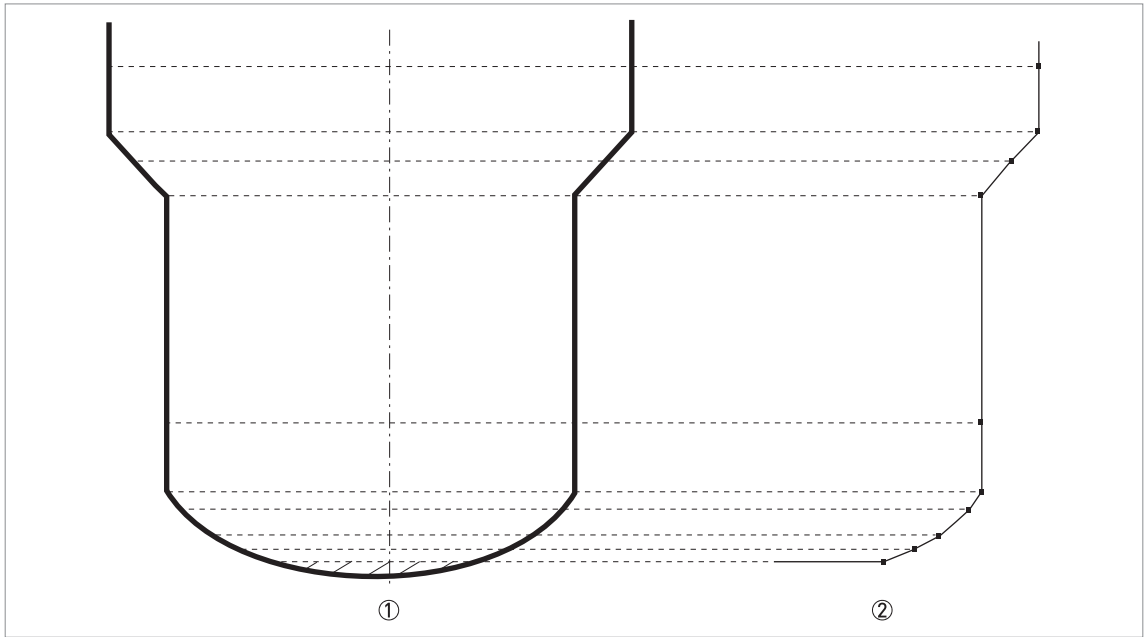

Figure 6-6: A plot of points for a volume or mass table

- ① Tank with reference points
- ② Tank model with plotted points



How to delete a volume or mass table.

- Enter the supervisor menu.
- Push 7 × [▲], [➤], and [▲] to go to 2.8.2 DELETE TABLE.
- Push [➤] and [▲] to set the parameter to **YES**.
- Push [←] to go back to the "STORE" screen.
- Push [▲] or [▼] to set the screen to **STORE YES** and push [←].
- ➡ The device will delete the data for the strapping table and go back to normal mode. The "CONVERSION" and "ULLAGE CONV." data are not available in normal mode.

6.4.8 How to make a filter to remove radar signal interference

If the device measures level in a tank that contains obstructions (agitator, supports, heating pipes etc.), these objects can cause radar signal interference (parasitic signals). You can use the empty spectrum function (menu item 2.1.2) in the Commissioning menu to make a filter to remove radar signal interference.



INFORMATION!

We recommend that you do an empty spectrum scan when the tank is empty and all the moving parts (agitators etc.) are in operation..

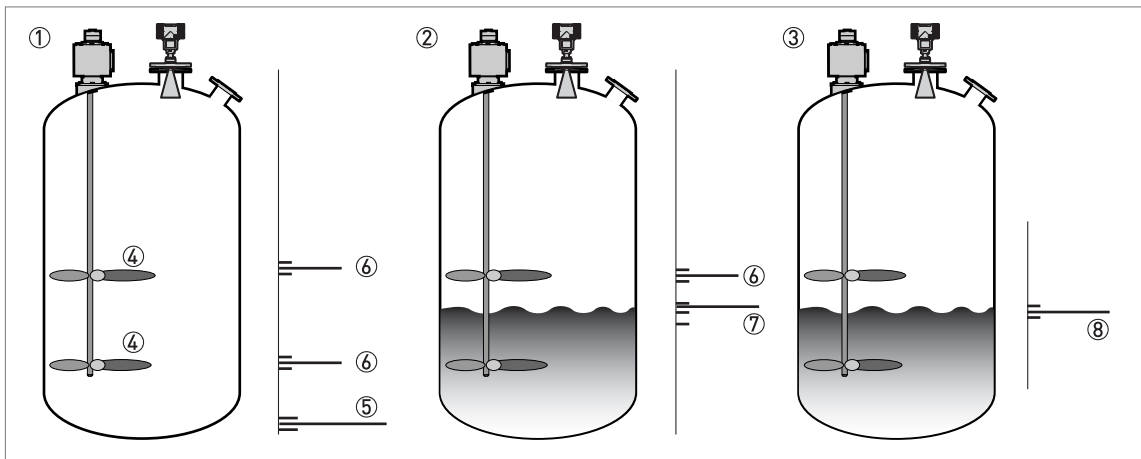

Figure 6-7: How to make a filter to remove radar signal interference

- ① Empty tank before the device uses the empty spectrum scan (with a graph of reflections shown)
- ② Partially filled tank before the device uses the empty spectrum scan (with a graph of reflections shown)
- ③ Partially filled tank after the device uses the empty spectrum scan (with a graph of reflections shown)
- ④ Agitator blades location
- ⑤ Tank bottom signal
- ⑥ Agitator blades signals (interference signals) before the device does the empty spectrum scan
- ⑦ Bad quality (mixed) signals of the liquid and the agitator blades before the device does the empty spectrum scan
- ⑧ Reflected signal if the device uses the data from the empty spectrum scan. The device only uses the reflection on the surface of the liquid to measure distance.



- After you enter the supervisor menu, push 2 x [>] and [▲] to go to the menu item EMP.SPEC.REC. (2.1.2).
- Do you have a completely filled tank? Select **Yes** or **No** and then push [←].
- ➡ If you select **Yes**, the device will not do the empty spectrum scan. Empty the tank and repeat the procedure.
- Are all the moving parts switched on? Select **Yes** or **No** and then push [←].
- Is your tank partially filled or completely empty? Select **Partially filled** or **Empty** and then push [←].
- Measured distance. If the tank is partially filled, enter the distance to the product surface - 300 mm / 12". The device must include the tank contents when it filters the signal
- Do you want to use the average value or the maximum value? Select **Average** or **Maximum** and then push [←].
- ➡ Use the maximum for tanks that have moving parts. Use the average value for tanks that do not have moving parts. The device will do an empty spectrum scan and then show the results on the signal screen.
- Make a selection from the available spectra to identify the correct level signal. Push [←].
- Do you want to save the spectrum? Select **Yes** or **No** and then push [←].
- ➡ If you select **Yes**, the device will use the empty spectrum scan results to make a filter to remove radar signal interference.



INFORMATION!

For more data on empty spectrum scans, refer to Function description on page 65 - table 2: Supervisor (menu item 2.1.2).

6.5 Status and error messages

6.5.1 Device status (markers)

If the device senses a change in device status, the display screen will show 1 or more status markers at the bottom right side of the display screen. The display screen will also show a symbol that agrees with NAMUR Recommendation NE 107 (Self-Monitoring and Diagnosis of Field Devices) and VDI/VDE 2650. This is shown at the top left side of the display screen. More data is given if you use PACTware™ software with the appropriate DTM on a PC. Error codes and data are shown on the device display screen and in the DTM.

Menu item 2.2.2 DIAGNOSTIC (Configuration mode / Supervisor menu) supplies more data. This includes internal voltages, the loop current and the reset counter (watchdog timer). You can see this data on the device display screen and in the DTM.

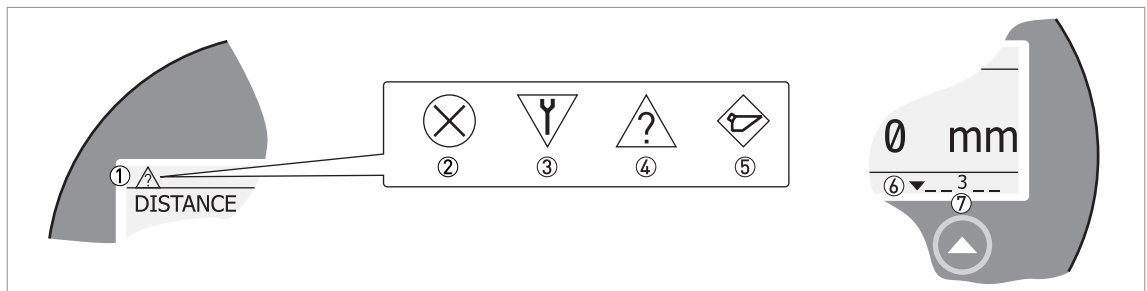

Figure 6-8: Status markers

- ① Device status (NAMUR NE 107 symbols)
- ② Symbol: Failure
- ③ Symbol: Function check
- ④ Symbol: Out of specification
- ⑤ Symbol: Maintenance
- ⑥ Status marker line (marker 3 is shown)
- ⑦ When the status marker is on, a number is shown

Types of error message

NE 107 status	Type of error	Description
Failure	Error	If an error message is shown in ERROR RECORD (menu item 1.3.1), the current output goes to the error signal value set in menu item RANGE I (menu item 2.4.2) after the time set in ERROR DELAY (menu item 2.4.5). For more data about menu items, refer to <i>Function description</i> on page 65.
Out of specification	Warning	If a warning message is shown, there is no effect on the current output value.
Maintenance		

NE 107 symbol shown	NE 107 Status	Description	Status marker shown	Error code (Type)	Possible errors
	Failure	The device does not operate correctly. The fault message stays on. The user cannot remove the "Failure" message from the Normal mode screen.	1	ERR 101 (Error)	Current Output Drift
			3	ERR 102 (Error)	Temperature Out of Range
			1	ERR 103 (Error)	Converter EEPROM
			1	ERR 103 (Error)	Converter RAM
			1	ERR 103 (Error)	Converter ROM
			1	ERR 104 (Error)	Converter Voltage
			1	ERR 200 (Error)	Internal Communication
			2, 4	ERR 201 (Error)	Overfill
			2, 4	ERR 203 (Error)	Peak Lost (Level Lost)
			3	ERR 204 (Error)	Sensor no Signal
			1	ERR 206 (Error)	Sensor Microwave
			1	ERR 207 (Error)	Sensor EEPROM
			1	ERR 207 (Error)	Sensor RAM
			1	ERR 207 (Error)	Sensor ROM
1	ERR 208 (Error)	Sensor Voltage			
1	ERR 210 (Error)	Sensor Not compatible			
	Function check	The device operates correctly, but the measured value is incorrect. This fault message is only temporary. This symbol is shown when the user configures the device with the DTM or a HART® Communicator.	-	-	-
	Out of specification	It is possible that the measured value is unstable if the operating conditions do not agree with the device specification.	4	(Warning)	Peak Lost
			4	(Warning)	Overfill
			3	(Warning)	Temperature out of range
	Maintenance	The device does not operate correctly because of bad environmental conditions (e.g. build-up on the antenna). The measured value is correct, but maintenance is necessary a short time after this symbol is shown.	5	(Warning)	Empty Spectrum Invalid
			4	(Warning)	Signal Weak
			4	(Warning)	Signal Strong
			4	(Warning)	Bad Measurement Quality
			3	(Warning)	Temperature <-35°C / -31°F
			3	(Warning)	Temperature >+75°C / +167°F

If an "Out of specification" or a "Maintenance" status symbol is shown, refer to menu item 2.2.2 DIAGNOSTIC (Configuration mode / Supervisor menu) for more data.

For data on errors, error records and error codes, refer to *Error handling* on page 83.

6.5.2 Error handling

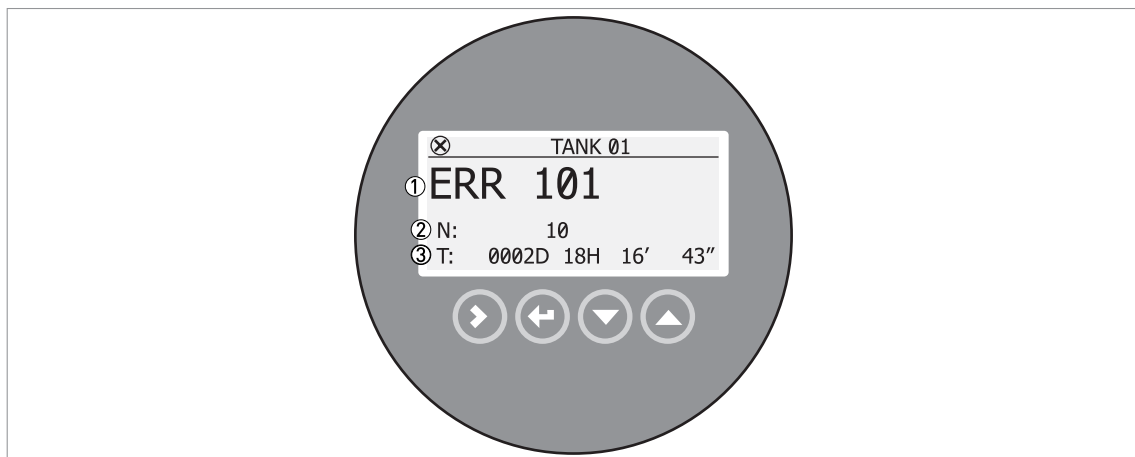

Figure 6-9: Error record data

- ① Error code for the error
- ② Number of times the error occurred
- ③ Time since the last error record (2 days, 18 hours, 16 minutes and 43 seconds shown in this example)



How to find an error record

- Push [➤] to enter configuration mode from normal mode.
- Push [➤], 2 × [▲] and [➤] to go to menu item 1.3.1 ERROR RECORD.
- Push 2 × [➤] to look at the error list. Push [▲] or [▼] for the selection of an error.
- ➡ The error record gives the number of times the error occurred and the time since the last error message.



INFORMATION!

The time since the error occurred is measured in Days (D), Hours (H), Minutes (') and Seconds ("). It only includes the time when the device is energized. The error is saved in the memory of the device when it is de-energized. The counter continues when the device is energized again.

Description of errors and corrective actions

Error code	Error Message	Status marker shown	Cause	Corrective action
------------	---------------	---------------------	-------	-------------------

Failure (NE 107 status signal)

ERR 100	Device reset	1	The device detected an internal error (watchdog timer issue).	Record the data that is in menu item 2.2.2 DIAGNOSTIC (Configuration mode / Supervisor menu). Speak to the supplier.
ERR 101	Current Output Drift	1	The current output is not calibrated.	Speak to the supplier to get the calibration procedure.
		1	Hardware error.	Replace the device.
ERR 102	Temperature out of range	1	The ambient temperature is outside the given range. This can cause loss or corruption of data.	Measure the ambient temperature. De-energize the device until the ambient temperature is back in the given range. If the temperature does not stay in the correct range, make sure that there is insulation around the signal converter. If this error occurs 2 times, replace the device.
ERR 103	Converter memory failure	1	The device's hardware is defective.	Replace the signal converter. For more data, refer to <i>How to turn or remove the signal converter</i> on page 35.
ERR 104	Converter Voltage failure	1	The device's hardware is defective.	Replace the signal converter. For more data, refer to <i>How to turn or remove the signal converter</i> on page 35.
ERR 200	Internal Communication	1	The device's hardware or software is defective. The converter cannot transmit signals to or receive signals from the antenna electronics.	De-energize the device. Make sure that the signal cable engages in the terminal and the screw connection is tight. Energize the device. If the problem continues, replace the signal converter. For more data, refer to <i>How to turn or remove the signal converter</i> on page 35.
ERR 201	Overfill	2	The level is in the blocking distance. There is a risk that the product will overflow and/or cover the antenna.	Use a different procedure to measure the level in the tank. Remove some of the product until the level is below the blocking distance.
				If a viscous product touched the antenna: <ul style="list-style-type: none"> remove the device and clean the antenna, or If the device has a purging option, use the purging system to clean the antenna.
ERR 203	Peak Lost (Level Lost)	2	The signal peak is not found within the measuring window that filters the signals received by the antenna. The measurement is not correct. The device will automatically increase this window to find the correct signal.	Do a check of the device, tank and the process. Reconfigure the device and record a new empty spectrum. Follow the instructions on page 79. If necessary, speak to the supplier.
ERR 204	Sensor no Signal	3	The device's hardware is defective.	Replace the signal converter. For more data, refer to <i>How to turn or remove the signal converter</i> on page 35.

Error code	Error Message	Status marker shown	Cause	Corrective action
ERR 206	Sensor Microwave failure	1	The device's hardware is defective.	Replace the signal converter. For more data, refer to <i>How to turn or remove the signal converter</i> on page 35.
ERR 207	Sensor Memory failure	1	The device's hardware is defective.	Replace the signal converter. For more data, refer to <i>How to turn or remove the signal converter</i> on page 35.
ERR 208	Sensor Voltage failure	3	The device's hardware is defective.	Do a check of the power supply at the device terminals. Make sure that voltage values are in the specified limits in menu item 2.2.2 DIAGNOSTIC (Configuration mode / Supervisor menu). If the voltage is correct, replace the signal converter. For more data on how to replace the signal converter, refer to <i>How to turn or remove the signal converter</i> on page 35.
ERR 210	Sensor Not compatible	1	The software version of the sensor is not compatible with the software version of the signal converter.	Go to menu 1.1.0 IDENT. in Configuration mode. Record the version numbers of the device software given in menu items 1.1.2, 1.1.3 and 1.1.4. Give this data to the supplier.
		1	Defective wiring.	

Out of specification (NE 107 status signal)

ERR 102	Temperature Out of Range	1	The ambient temperature is outside the given range. This can cause loss or corruption of data.	Measure the ambient temperature. De-energize the device until the ambient temperature is back in the given range. If the temperature does not stay in the correct range, make sure that there is insulation around the signal converter. If this error occurs 2 times, replace the device.
ERR 201	Overfill	2	The level is in the blocking distance. There is a risk that the product will overflow and/or cover the device.	Remove some of the product until the level is below the blocking distance.
ERR 203	Peak Lost	2	The signal peak is not found within the measuring window that filters the signals received by the antenna. The measurement is not correct. The device will automatically increase this window to find the correct signal.	Do a check of the device, tank and the process and make sure that the data agrees with the device configuration. If necessary, record a new empty spectrum. Follow the instructions on page 79. If necessary, speak to the supplier.

Maintenance (NE 107 status signal)

-	Empty Spectrum Invalid	5	The empty spectrum stored in the device does not agree with the installation. If you change the device configuration (tank height etc.), this message will be shown. The recorded empty spectrum will not be used by the device while this error message is shown. ①	Record a new empty spectrum. Follow the instructions on page 79.
---	------------------------	---	--	--

Error code	Error Message	Status marker shown	Cause	Corrective action
–	Signal Weak	4	The signal amplitude is less than the average value. This can occur if the liquid is agitated or if there is foam in the tank. If this error occurs frequently, the device will possibly show the "Peak Lost (Level Lost)" error message. ①	If this error occurs frequently, it is possible that you must install the device in a stilling well or use a different antenna type.
–	Signal Strong	4	This error can occur if there is a large change in signal amplitude. ①	No corrective action is necessary.
–	Bad Measurement Quality	4	The measurement is incorrect and continues to be incorrect after more than 10 s. This error can occur if the tank contents are immediately below the antenna. ①	Record the process with the PACTware™ software tool to find the cause of the problem. If necessary, speak to the supplier.
–	Temperature <-35°C / -31°F	3	The process connection or the ambient temperature is less than -35°C / -31°F. This temperature is near to the minimum limit for device operation. ①	Measure the ambient temperature. De-energize the device until the ambient temperature is back in the given range. If the temperature does not stay in the correct range, make sure that there is insulation around the signal converter.
–	Temperature >+75°C / +167°F	3	The ambient temperature is more than +75°C / +167°F. This temperature is near to the maximum limit for device operation. ①	Measure the ambient temperature. De-energize the device until the ambient temperature is back in the given range. If the temperature does not stay in the correct range, make sure that there is insulation around the signal converter.

① This error message does not have an effect on the current output signal



INFORMATION!

In 4.0.0 MASTER menu, the type of error shown for error codes 102, 201 and 203 can be changed from "Error" to "Warning" (the NE 107 status signal changes from "Failure" to "Out of specification"). For more data, speak to the supplier.

7 Service

7.1 Periodic maintenance

No maintenance is necessary. If it is possible that there will be build-up on the antenna, clean the antenna regularly. If your device has the purge option, refer to *How to clean horn antennas under process conditions* on page 87.



WARNING!
Do not use bleach to clean the signal converter.

7.2 How to clean horn antennas under process conditions

If it is possible that there will be build-up, a purging option is available for DN150 / 6" and DN200 / 8" Metallic Horn antennas. Purge the antenna at intervals to make sure that the inner surface of the antenna stays clean and the device measures accurately. For more data about dimensions, refer to *Dimensions and weights* on page 108 (Purging and heating/cooling system options).

Purging system

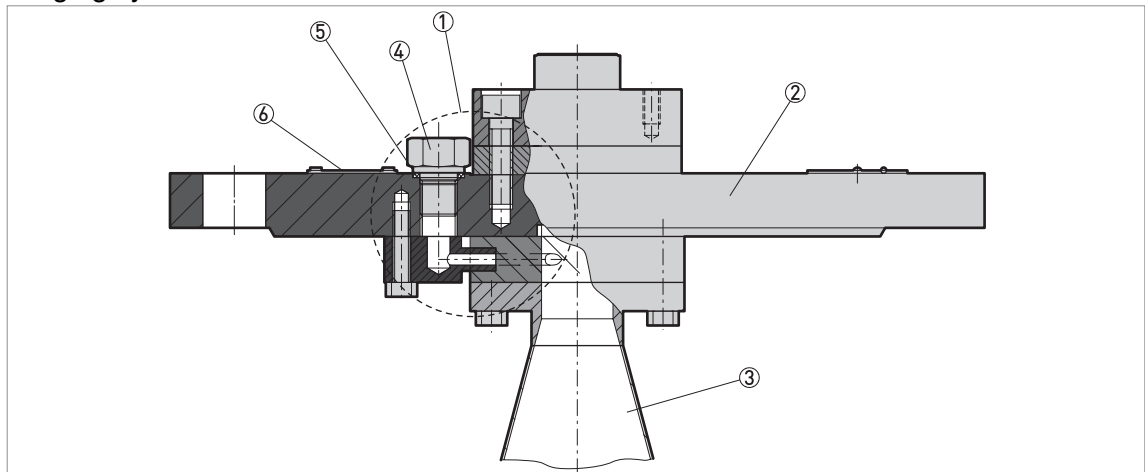

Figure 7-1: Purging system

- ① Purging system
- ② Flange connection
- ③ Metallic Horn antenna
- ④ G 1/4 plug for the purging system
- ⑤ Seal
- ⑥ Warning label - see the illustration that follows

Warning label

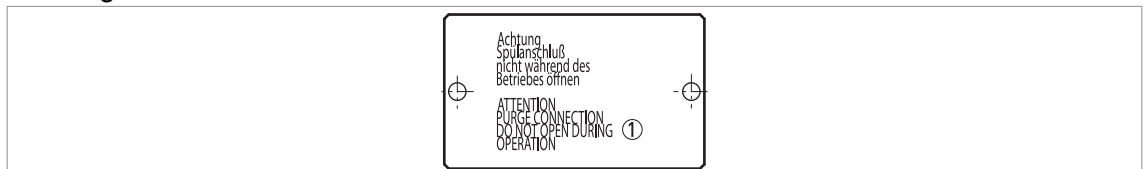

Figure 7-2: Warning label (on the top face of the flange connection)

- ① Text: Attention! Purge connection. Do not open during operation.



WARNING!
Purge the antenna with a dry gas or liquid that is applicable to the process. For more data, refer to the table that follows:

How to use the purge

Process conditions	How to use the purge
The device is colder than other elements in the process. It is possible that there will be condensation in the antenna.	Continuous use. Use low-pressure gas to remove condensation from the antenna.
There is a risk of build-up in the antenna	Purge at intervals. Use compressed air, nitrogen or another gas that is applicable to the process up to 6 bar / 87 psi.
There is a build-up or risk of build-up in the antenna	Purge at intervals. Use a liquid (hot water, solvent or another liquid that is applicable to the process) to melt the liquid that has crystallized on the antenna.

7.3 Heating or cooling horn antennas under process conditions

A heating / cooling system option is available for DN150 / 6" and DN200 / 8" Metallic Horn antennas. The outer surface of the antenna is sealed in a metal heating / cooling jacket. There is an inlet and an outlet for the heating / cooling jacket on the top of the flange. For more data about dimensions, refer to *Dimensions and weights* on page 108 (Purging and heating/cooling system options).



WARNING!

Make sure the the pressure in the heating / cooling system is not more than 6 bar / 87 psi. Make sure that the flange temperature is not more than the maximum limit. For more data, refer to Technical data on page 93.

It is also possible to use a purging system with the heating / cooling system. For more data, refer to *How to clean horn antennas under process conditions* on page 87.

7.4 How to replace device components

7.4.1 Service warranty



WARNING!

Only approved personnel can do an inspection of the device and repairs. If you find a problem, send the device back to the supplier for inspection and/or repairs.



INFORMATION!

*The converter housing (compact or remote version) can be detached from the process connection assembly under process conditions. For more data, refer to *How to turn or remove the signal converter* on page 35.*

Servicing by the customer is limited by warranty to:

- The removal and installation of the device.
- **Compact version:** The removal and installation of the signal converter (with the weather protection, if this option is attached). For more data, refer to *How to turn or remove the signal converter* on page 35.
- **Remote (field) version:** The removal and installation of the remote converter and/or the antenna housing. For more data, refer to *How to turn or remove the signal converter* on page 35.

For more data on how to prepare the device before you send it back, refer to *Returning the device to the manufacturer* on page 89.

7.5 Spare parts availability

The manufacturer adheres to the basic principle that functionally adequate spare parts for each device or each important accessory part will be kept available for a period of 3 years after delivery of the last production run for the device.

This regulation only applies to spare parts which are subject to wear and tear under normal operating conditions.

7.6 Availability of services

The manufacturer offers a range of services to support the customer after expiration of the warranty. These include repair, maintenance, technical support and training.



INFORMATION!

For more precise information, please contact your local sales office.

7.7 Returning the device to the manufacturer

7.7.1 General information

This device has been carefully manufactured and tested. If installed and operated in accordance with these operating instructions, it will rarely present any problems.



CAUTION!

Should you nevertheless need to return a device for inspection or repair, please pay strict attention to the following points:

- *Due to statutory regulations on environmental protection and safeguarding the health and safety of our personnel, manufacturer may only handle, test and repair returned devices that have been in contact with products without risk to personnel and environment.*
- *This means that the manufacturer can only service this device if it is accompanied by the following certificate (see next section) confirming that the device is safe to handle.*



CAUTION!

If the device has been operated with toxic, caustic, flammable or water-endangering products, you are kindly requested:

- *to check and ensure, if necessary by rinsing or neutralising, that all cavities are free from such dangerous substances,*
- *to enclose a certificate with the device confirming that is safe to handle and stating the product used.*

7.7.2 Form (for copying) to accompany a returned device

Company:		Address:	
Department:		Name:	
Tel. no.:		Fax no.:	
Manufacturer's order no. or serial no.:			
The device has been operated with the following medium:			
This medium is:	water-hazardous		
	toxic		
	caustic		
	flammable		
	We checked that all cavities in the device are free from such substances.		
	We have flushed out and neutralized all cavities in the device.		
We hereby confirm that there is no risk to persons or the environment through any residual media contained in the device when it is returned.			
Date:		Signature:	
Stamp:			

7.8 Disposal

**CAUTION!**

Disposal must be carried out in accordance with legislation applicable in your country.

8 Technical data

8.1 Measuring principle

A radar signal is emitted via an antenna, reflected from the product surface and received after a time t . The radar principle used is FMCW (Frequency Modulated Continuous Wave).

The FMCW-radar transmits a high frequency signal whose frequency increases linearly during the measurement phase (called the frequency sweep). The signal is emitted, reflected on the measuring surface and received with a time delay, t . Delay time, $t=2d/c$, where d is the distance to the product surface and c is the speed of light in the gas above the product.

For further signal processing the difference Δf is calculated from the actual transmitted frequency and the received frequency. The difference is directly proportional to the distance. A large frequency difference corresponds to a large distance and vice versa. The frequency difference Δf is transformed via a Fourier transformation (FFT) into a frequency spectrum and then the distance is calculated from the spectrum. The level results from the difference between tank height and measuring distance.

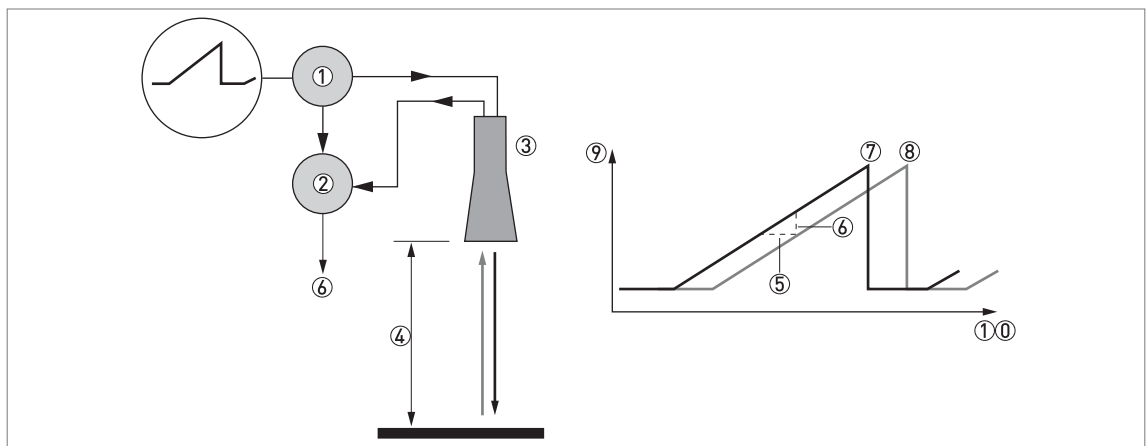

Figure 8-1: Measuring principle of FMCW radar

- ① Transmitter
- ② Mixer
- ③ Antenna
- ④ Distance to product surface, where change in frequency is proportional to distance
- ⑤ Differential time delay, Δt
- ⑥ Differential frequency, Δf
- ⑦ Frequency transmitted
- ⑧ Frequency received
- ⑨ Frequency
- ⑩ Time

Measurement modes

"Direct" mode

If the dielectric constant of the liquid is high ($\epsilon_r \geq 1.8$), the level signal is a reflection on the surface of the liquid.

"TBF Partial" mode

If the dielectric constant of the liquid is low ($\epsilon_r \geq 1.8$, for long distance measurement), you must use "TBF Partial" mode to measure level correctly. TBF Partial" is an automatic mode that lets the device make a selection between "Direct mode and "TBF" mode. If the device finds a large radar reflection above the "tank bottom area" (the bottom 20% of the tank height), the device will use "Direct" mode. If the device finds a large radar reflection in the "tank bottom area", the device uses TBF mode. This mode can be used only in tanks with flat bottoms.

"Full TBF" mode

TBF = Tank Bottom Following. If the dielectric constant of the liquid is very low ($\epsilon_r < 1.8$), you must use "Full TBF" mode to measure level correctly. The device uses the radar reflection on the bottom of the tank (the signal goes through the liquid). This mode can be used only in tanks with flat bottoms.



CAUTION!

"FULL TBF" AND "TBF PARTIAL" MODES

It is important to enter the correct dielectric constant value in menu item 2.5.3 Er Product. If not, the device will not measure level accurately.

8.2 Technical data



INFORMATION!

- The following data is provided for general applications. If you require data that is more relevant to your specific application, please contact us or your local sales office.
- Additional information (certificates, special tools, software,...) and complete product documentation can be downloaded free of charge from the website.

Measuring system

Measuring principle	2-wire loop-powered level transmitter; X-band (10 GHz) FMCW radar
Application range	Level measurement of liquids, pastes and slurries
Primary measured value	Distance and reflection
Secondary measured value	Level, volume, mass and flow rate

Design

Construction	The measurement system consists of a measuring sensor (antenna) and a signal converter
Options	Integrated LCD display (-20...+60°C / -4...+140°F); if the ambient temperature is not in these limits, the display switches off automatically
	High-temperature (HT) extension (if the process connection temperature is more than +150°C / +302°F - Metallic Horn antenna only)
	Straight antenna extensions Max. extension length, PTFE Wave Horn antenna: 300 mm / 11.8"; Max. extension length, Metallic Horn antenna: 1000 mm / 39.4"
	"S" antenna extension - only for DN150/6" and DN200/8" Metallic Horn antenna options
	"L" (right angle) antenna extension - only for DN150/6" and DN200/8" Metallic Horn antenna options
	Antenna purging system - only for DN150/6" and DN200/8" Metallic Horn antenna options
	Heating / cooling system (with or without the antenna purging system) - only for DN150/6" and DN200/8" Metallic Horn antenna options
	Signal cable for remote housing version (refer to cable properties in "Electrical connection: Remote device version")
Weather protection - for the compact version or the antenna housing (remote version). It cannot be ordered after delivery of the device.	
Max. measuring range	PTFE and PP Wave Horn antennas: 20 m / 65.6 ft
	DN80 / DN100 Metallic Horn antennas (installation only in stilling wells): 10 m / 32.8 ft
	DN150 / DN200 Metallic Horn antennas: 30 m / 98.4 ft
	Wave Guide antenna: 6 m / 32.8 ft
	Also depends on the dielectric constant of the product and the installation type. Refer also to "Antenna selection".
Min. tank height	1 m / 3.3 ft
Top dead zone	Minimum value: Antenna length + antennna extension length + 100 mm / 3.9"

Beam angle (½ angle) of antenna	PP Wave Horn: 10°
	PTFE Wave Horn: 10°
	Metallic Horn DN80 / 3": 16° - used only in stilling wells
	Metallic Horn DN100 / 4": 12° - used only in stilling wells
	Metallic Horn DN150 / 6": 8°
	Metallic Horn DN200 / 8": 6°
	Wave Guide / stilling well: n/a - the radar signal is inside the tube.
Display and user interface	
Display	LCD display
	128 × 64 pixels in 8-step greyscale with 4-button keypad
Interface languages	3 language pack options (the language is given in the customer order): ① English, French German and Italian ② English, French, Spanish and Portuguese ③ English, Chinese (Mandarin), Japanese and Russian

Measuring accuracy

Resolution	1 mm / 0.04"
Repeatability	±1 mm / ±0.04"
Accuracy	Standard: ±10 mm / ±0.4", when distance < 10 m / 33 ft; ±0.1% of measured distance, when distance > 10 m / 33 ft Option: ±5 mm / ±0.2", when distance < 10 m / 33 ft; ±0.05% of measured distance, when distance > 10 m / 33 ft
Reference conditions acc. to EN 61298-1	
Temperature	+15...+25°C / +59...+77°F
Pressure	1013 mbara ±50 mbar / 14.69 psia ±0.73 psi
Relative air humidity	60% ±15%
Target	Metal plate in an anechoic chamber

Operating conditions

Temperature	
Ambient temperature	-40...+80°C / -40...+176°F Ex: see supplementary operating instructions or approval certificates
Storage temperature	-50...+85°C / -58...+185°F
Process connection temperature (higher temperature on request)	PP Wave Horn antenna: -20...+100°C / -4...+212°F
	PTFE Wave Horn antenna: -50...+150°C / -58...+302°F
	Metallic Horn antenna / Wave Guide antenna: Standard: FKM/FPM (-40...+150°C (+200°C with an HT extension) / -40...+302°F (+392°F with an HT extension)); Options: Kalrez® 6375 (-20...+150°C (+250°C with an HT extension) / -4...+302°F (+482°F with an HT extension)); PFA (-60°C...+130°C / -76...+266°F); EPDM (-50...+130°C / -58...+266°F) The process connection temperature must agree with the temperature limits of the gasket material. Ex: see supplementary operating instructions or approval certificates ①
Pressure	
Process pressure	PP Wave Horn antenna: -1...16 barg / -14.5...232 psig. For more data, refer to <i>Pressure ratings</i> on page 101.
	PTFE Wave Horn antenna: -1...40 barg / -14.5...580 psig. For more data, refer to <i>Pressure ratings</i> on page 101.
	Metallic Horn antenna / Wave Guide antenna: Standard: -1...40 barg / -14.5...580 psig; subject to the process connection used and the flange temperature. Higher pressure on request.

Purging system (option)	Max. 6 barg / 87 psig (higher pressure on request)
Heating / cooling system (option)	Max. 6 barg / 87 psig (higher pressure on request)
Other conditions	
Dielectric constant (ϵ_r)	Direct mode: ≥ 1.8 TBF mode: ≥ 1.1 Refer also to "Technical data: Antenna selection".
Ingress protection	IEC 60529: IP 66/67 NEMA 250: NEMA type 4X (housing) and type 6P (antenna)
Maximum rate of change	10 m/min / 32.8 ft/min

Installation conditions

Process connection size	The nominal diameter (DN) should be equal to or larger than the antenna diameter.
Process connection position	Make sure that there are not any obstructions directly below the process connection for the device. For more data, refer to <i>Installation</i> on page 18.
Dimensions and weights	For dimensions and weights data, refer to <i>Dimensions and weights</i> on page 108.

Materials

Housing	Standard: Polyester-coated aluminium
	Option: Stainless steel (1.4404 / 316L)
Antenna options / Wetted materials	PTFE Wave Horn antenna with a PTFE flange cladding
	PP Wave Horn antenna with a PP jacket/threaded process connection
	Stainless steel (1.4404 / 316L) Metallic Horn antenna with a PTFE process seal and an FKM/FPM, EPDM, Kalrez® 6375 or PFA O-ring gasket
	Stainless steel (1.4404 / 316L) Wave Guide antennas with a PTFE process seal and an FKM/FPM, EPDM, Kalrez® 6375 or PFA O-ring gasket
Feedthrough	PP Wave Horn antenna: this is a single-piece antenna (the feedthrough is filled with PP)
	PTFE Wave Horn antenna: this is a single-piece antenna (the feedthrough is filled with PTFE)
	Metallic Horn and Wave Guide antennas: Dual process seal system - 1st seal: PTFE with O-ring gasket , 2nd seal: Metaglas® with O-ring gasket ②
Cable gland	Standard: none
	Options: Plastic (Non-Ex: black, Ex i-approved: blue); nickel-plated brass; stainless steel
Weather protection (Option)	Stainless steel (1.4404 / 316L)

Process connections

Thread	PP Wave Horn antenna: G 1½; 1½ NPT
Flange version	
EN	PTFE Wave Horn antenna: DN50...150 in PN16, PN40
	Metallic Horn and Wave Guide antennas: DN80...200 in PN16, PN40; others on request
ASME	PTFE Wave Horn antenna: 2"...6" in 150 lb / 300 lb
	Metallic Horn and Wave Guide antennas: 3"...8" in 150 lb / 300 lb; others on request
JIS	PTFE Wave Horn antenna: 50...150A in 10K
	Metallic Horn and Wave Guide antennas: 80...200A in 10K; others on request
Other	Others on request

Electrical connections

Power supply	Terminals output - Non-Ex / Ex i: 12...30 VDC; min./max. value for an output of 22 mA at the terminal
	Terminals output - Ex d: 16...36 VDC; min./max. value for an output of 22 mA at the terminal
Maximum current	22 mA
Current output load	Non-Ex / Ex i: $R_L [\Omega] \leq ((U_{ext} - 12 \text{ V})/22 \text{ mA})$. For more data, refer to <i>Minimum power supply voltage</i> on page 100.
	Ex d: $R_L [\Omega] \leq ((U_{ext} - 16 \text{ V})/22 \text{ mA})$. For more data, refer to <i>Minimum power supply voltage</i> on page 100.
Cable entry	Standard: M20x1.5; Option: ½ NPT
Cable gland	Standard: none
	Options: M20x1.5 (cable diameter: 6...10 mm / 0.2...0.39"); others are available on request
Cable entry capacity (terminal)	0.5...2.5 mm ²

Input and output

Current output / HART®	
Output signal	4...20 mA HART® or 3.8...20.5 mA acc. to NAMUR NE 43 ③
Resolution	±3 µA
Temperature drift	Typically 50 ppm/K
Digital temperature drift	Max. ±15 mm / 0.6" for the full temperature range
Error signal	High: 22 mA; Low: 3.6 mA acc. to NAMUR NE 43 ④
PROFIBUS PA	
Type	PROFIBUS MDP interface that agrees with IEC 61158-2 with 31.25 kbit/s; voltage mode (MDP = Manchester Coded Bus Powered)
Function blocks	1 × Physical Block, 1 × Level Transducer Block, 4 × Analog Input Function Blocks
Device power supply	9...32 VDC - bus powered; no additional power supply required
Polarity sensitivity	No
Basic current	15 mA
FOUNDATION™ fieldbus	
Physical layer	FOUNDATION™ fieldbus protocol that agrees with IEC 61158-2 and FISCO model
Communication standard	H1
ITK version	6.1
Function blocks	1 × Resource Block (RB), 3 × Transducer Blocks (TB), 3 × Analog Input Blocks (AI), 1 × Proportional Integral Derivative Block (PID)
	Analog Input Block: 30 ms
	Proportional Integral Derivative Block: 40 ms
Device power supply	Not intrinsically safe: 9...32 VDC
	Intrinsically safe: 9...24 VDC
Basic current	14 mA
Maximum error current	20.5 mA (= basic current + error current = 14 mA + 6.5 mA)
Polarity sensitivity	No
Minimum cycle time	250 ms
Output data	Level, distance, ullage conversion, level conversion
Input data	None
Error current FDE	Typically 0 mA (FDE =Fault Disconnection Electronic)
Link Master function	Supported

Approvals and certification

CE	This device fulfils the statutory requirements of the EC directives. The manufacturer certifies successful testing of the product by applying the CE mark.
Vibration resistance	EN 60068-2-64 Metallic Horn (without antenna extension options): 5 Hz to 100 Hz: 4g Metallic Horn, PTFE or PP Wave Horn: 3.5 mm up to 8 Hz and 10 m/s ² : 1g, 8.5 to 2000 Hz
Explosion protection	
ATEX (Ex ia or Ex d) DEKRA xxATEXxxxx X	Compact version
	II 1/2 G, 2 G Ex ia IIC T6...T2 Ga/Gb or Ex ia IIC T6...T2 Gb;
	II 1/2 D, 2 D Ex ia IIIC T90°C Da/Db or Ex ia IIIC T90°C Db IP6X;
	II 1/2 G, 2 G Ex d ia IIC T6...T2 Ga/Gb or Ex d ia IIC T6...T2 Gb;
	II 1/2 D, 2 D Ex ia tb IIIC T90°C Da/Db or Ex ia tb IIIC T90°C Db IP6X
	Remote version, transmitter
	II 2 G Ex ia [ia Ga] IIC T6...T4 Gb;
	II 2 D Ex ia [ia Da] IIIC T90°C Db;
	II 2 G Ex d ia [ia Ga] IIC T6...T4 Gb;
	II 2 D Ex ia tb [ia Da] IIIC T90°C Db
	Remote version, sensor
	II 1/2 G Ex ia IIC T6...T2 Ga/Gb
	II 1/2 D Ex ia IIIC T90°C Da/Db
	II 1/2 G Ex ia IIC T6...T2 Gb
	II 1/2 D Ex ia IIIC T90°C Db
	ATEX (Ex ic) DEKRA xxATEXxxxx X
II 3 G Ex ic IIC T6...T2 Gc;	
II 3 D Ex ic IIIC T90°C Dc	
Remote version, transmitter	
II 3 G Ex ic [ic] IIC T6...T4 Gc;	
II 3 D Ex ic [ic] IIIC T90°C Dc	
Remote version, sensor	
II 3 G Ex ic IIC T6...T2 Gc;	
II 3 D Ex ic IIIC T90°C Dc	

<p>IECEEx IECEEx DEK xx.xxxx X</p>	<p>Compact version</p> <p>Ex ia IIC T6...T2 Ga/Gb or Ex ia IIC T6...T2 Gb or Ex ic IIC T6...T2 Gc; Ex ia IIIC T90°C Da/Db or Ex ia IIIC T90°C Db or Ex ic IIIC T90°C Dc; Ex d ia IIC T6...T2 or Ex d ia IIIC T6...T2 Gb; Ex ia tb IIIC T90°C Da/Db or Ex ia tb IIIC T90°C Db</p> <p>Remote version, transmitter</p> <p>Ex ia [ia Ga] IIC T6...T4 Gb or Ex ic IIC T6...T4 Gc; Ex ia [ia Da] IIIC T90°C Db or Ex ic [ic] IIIC T90°C Dc; Ex d ia [ia Ga] IIC T6...T4 Gb; Ex ia tb [ia Da] IIIC T90°C Db</p> <p>Remote version, sensor</p> <p>Ex ia IIC T6...T2 Ga/Gb or Ex ia IIC T6...T2 Gb or Ex ic IIC T6...T2 Gc; Ex ia IIIC T90°C Da/Db or Ex ia IIIC T90°C Db or Ex ic IIIC T90°C Dc</p>
<p>cFMus - Dual Seal-approved - for 4...20 mA HART output (pending for fieldbus options)</p>	<p>NEC 500 (Division ratings)</p> <p>XP-AIS / Cl. I / Div. 1 / Gr. ABCD / T6-T1; DIP / Cl. II, III / Div. 1 / Gr. EFG / T6-T1; IS / Cl. I, II, III / Div. 1 / Gr. ABCDEFG / T6-T1; NI / Cl. I / Div. 2 / Gr. ABCD / T6-T1</p> <p>NEC 505 (Zone ratings)</p> <p>Cl. I / Zone 0 / AEx d [ia] / IIC / T6-T1; Cl. I / Zone 0 / AEx ia / IIC / T6-T1; Cl. I / Zone 2 / AEx nA / IIC / T6-T1; Zone 20 / AEx ia / IIIC / T90°C Zone 20 / AEx tb [ia] / IIIC / T90°C Hazardous (Classified) Locations, indoor/outdoor Type 4X and 6P, IP66, Dual Seal</p> <p>CEC Section 18 (Zone ratings)</p> <p>Cl. I, Zone 0, Ex d [ia], IIC, T6-T1; Cl. I, Zone 0, Ex ia, IIC, T6-T1; Cl. I, Zone 2, Ex nA, IIC, T6-T1</p> <p>CEC Section 18 and Annex J (Division ratings)</p> <p>XP-AIS / Cl. I / Div. 1 / Gr. BCD / T6-T1 DIP / Cl. II, III / Div. 1 / Gr. EFG / T6-T1 IS / Cl. I / Div. 1 / Gr. BCD / T6-T1 NI / Cl. I / Div. 2 / Gr. ABCD / T6-T1</p>
<p>NEPSI</p>	<p>Ex ia IIC T2~T6 Gb or Ex ia IIC T2~T6 Ga/Gb DIP A20/A21 T_A T90°C IP6X Ex d ia IIC T2~T6 Gb or Ex d ia IIC T2~T6 Ga/Gb DIP A20/A21 T_A T90°C IP6X</p>

Other standards and approvals	
SIL	Compact version only: SIL 2 - according to EN 61508 and for high/low demand mode operation
EMC	Electromagnetic Compatibility Directive 2004/108/EC in conjunction with EN 61326-1 (2006) SIL 2-approved devices agree with EN 61326-3-1 (2008) and EN 61326-3-2 (2008)
Radio approvals	R & TTE Radio Equipment and Telecommunications Terminal Equipment Directive 1999/5/EC in conjunction with ESTI EN 302 372 (2006)
	FCC Rules Part 15
	Industry Canada RSS-210
LVD	Low-Voltage Directive 2006/95/EC in conjunction with EN 61010-1 (2001)
NAMUR	NAMUR NE 21 Electromagnetic Compatibility (EMC) of Industrial Process and Laboratory Control Equipment
	NAMUR NE 43 Standardization of the Signal Level for the Failure Information of Digital Transmitters
	NAMUR NE 53 Software and Hardware of Field Devices and Signal Processing Devices with Digital Electronics
	NAMUR NE 107 Self-Monitoring and Diagnosis of Field Devices
CRN	This certification is applicable for all Canadian provinces and territories. For more data, refer to the website.
Construction code	Metallic Horn and Wave Guide antennas: NACE MR0175 / ISO 15156; NACE MR0103

- ① If the process connection temperature is more than 150°C / 302°F and the device has Kalrez® 6375 or FKM/FPM gaskets, the device will also have an high temperature extension between the converter and the process connection. Kalrez® is a registered trademark of DuPont Performance Elastomers L.L.C. The process connection temperature must agree with the temperature limits of the gasket material.
- ② Metaglas® is a registered trademark of Herberts Industrieglas, GMBH & Co., KG
- ③ HART® is a registered trademark of the HART Communication Foundation
- ④ Only the 3.6 mA error signal is applicable to SIL-approved devices

8.3 Minimum power supply voltage

Use these graphs to find the minimum power supply voltage for a given current output load.

Non-Ex and Hazardous Location approved (Ex i / IS) devices

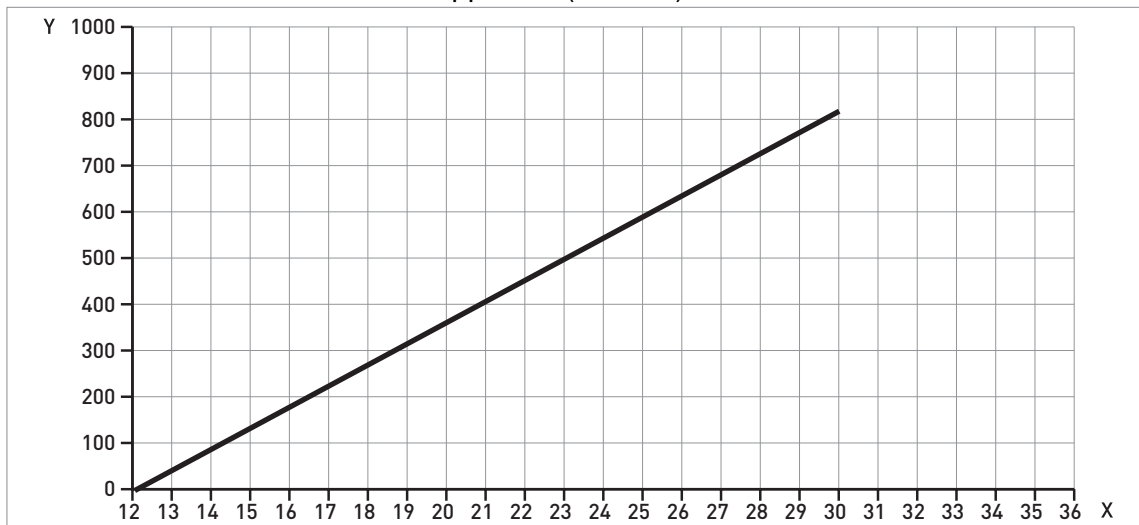

Figure 8-2: Minimum power supply voltage for an output of 22 mA at the terminal (Non-Ex and Hazardous Location approval (Ex i / IS))

X: Power supply U [VDC]

Y: Current output load R_L [Ω]

Hazardous Location (Ex d / XP/NI) approved devices

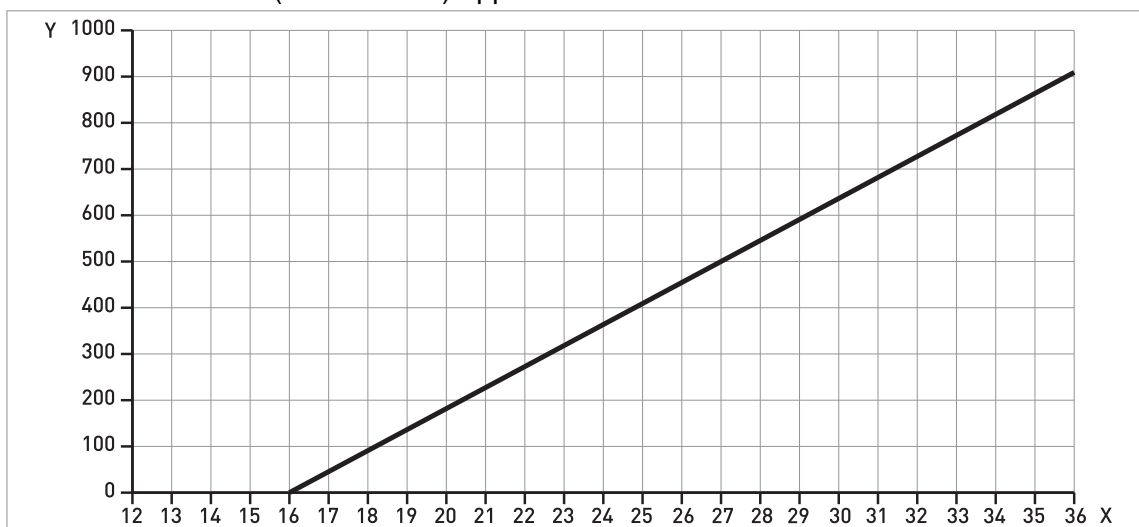

Figure 8-3: Minimum power supply voltage for an output of 22 mA at the terminal (Hazardous Location approval (Ex d / XP/NI))

X: Power supply U [VDC]

Y: Current output load R_L [Ω]

8.4 Pressure ratings



WARNING!
 Make sure that the devices are used within their operating limits.

EN flanges: Metallic Horn, Wave Guide and PTFE Wave Horn antennas

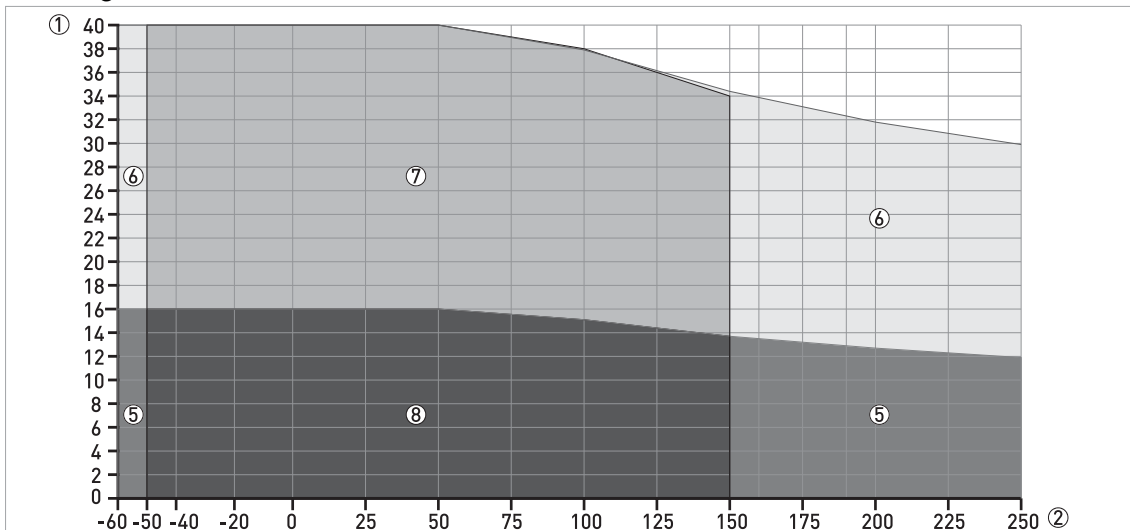

Figure 8-4: Pressure / temperature rating (EN 1092-1), flange connections, in °C and barg

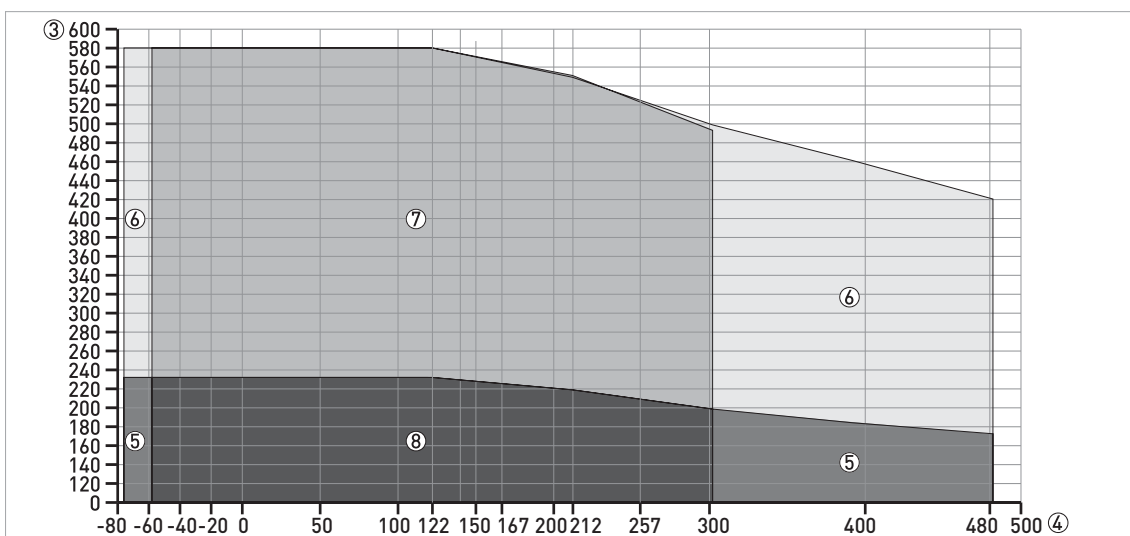

Figure 8-5: Pressure / temperature rating (EN 1092-1), flange connections, in °F and psig

- ① p [barg]
- ② T [°C]
- ③ p [psig]
- ④ T [°F]
- ⑤ Flange connection, PN16: Metallic Horn and Wave Guide antennas
- ⑥ Flange connection, PN40: Metallic Horn and Wave Guide antennas
- ⑦ Flange connection, PN40: Metallic Horn, Wave Guide and PTFE Wave Horn antennas
- ⑧ Flange connection, PN16: Metallic Horn, Wave Guide and PTFE Wave Horn antennas

ISO threaded connections: PP Wave Horn antenna

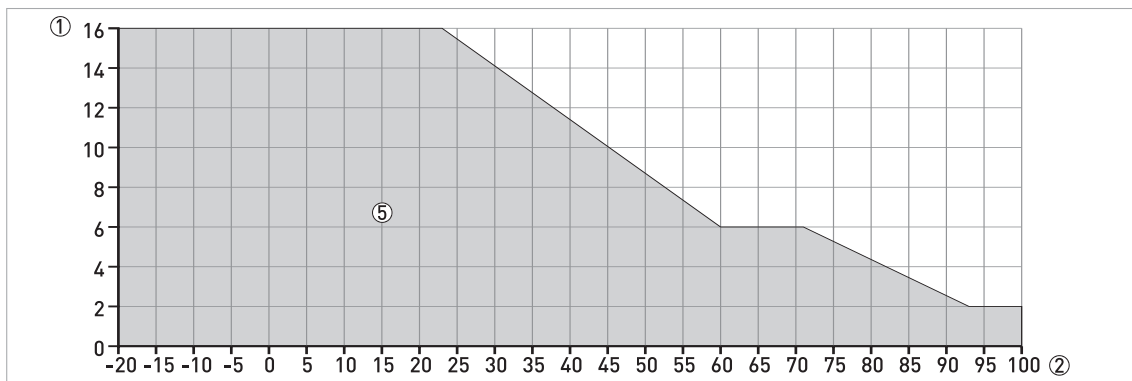

Figure 8-6: Pressure / temperature rating (ISO 228), threaded connection, in °C and barg

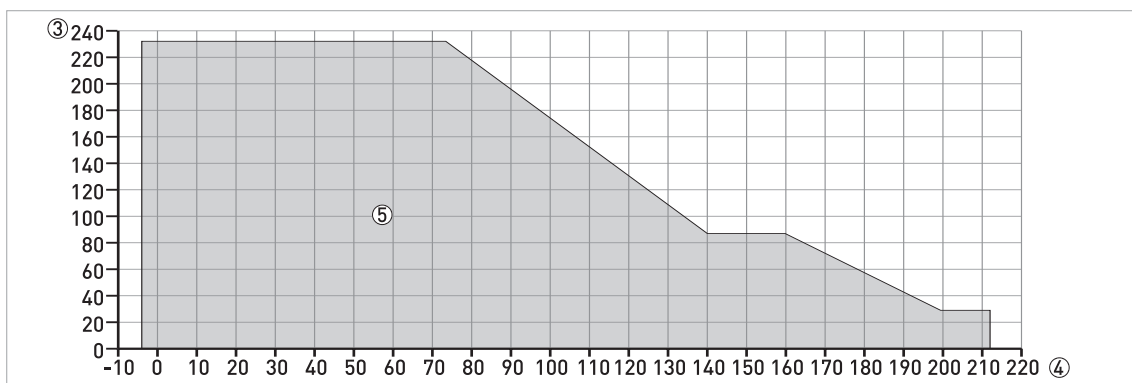

Figure 8-7: Pressure / temperature rating (ISO 228-1), threaded connection, in °F and psig

- ① p [barg]
- ② T [°C]
- ③ p [psig]
- ④ T [°F]
- ⑤ Threaded connection, G (ISO 228-1): PP Wave Horn antenna

ASME flanges: Metallic Horn, Wave Guide and PTFE Wave Horn antennas

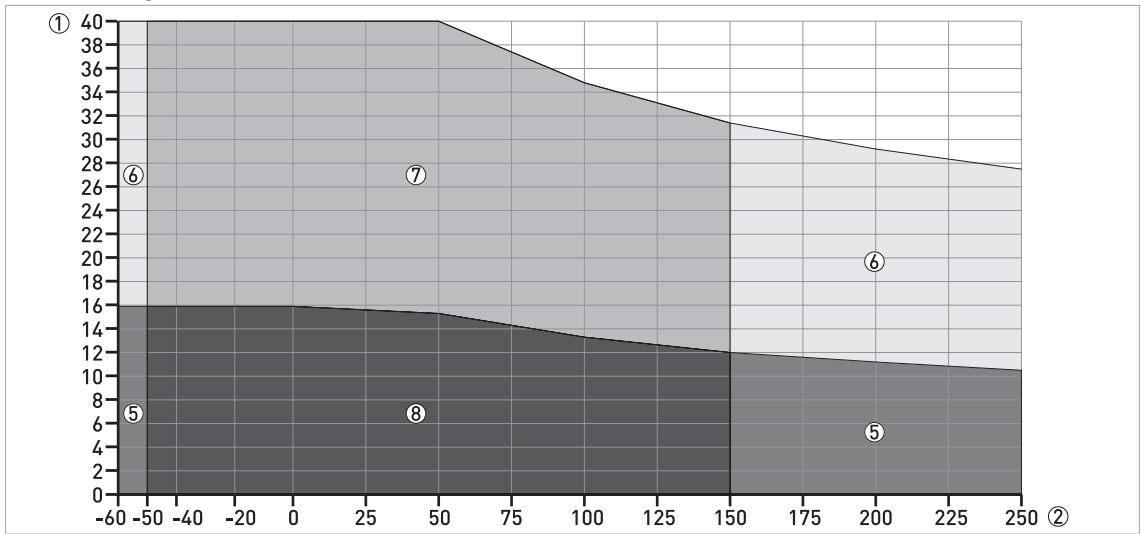

Figure 8-8: Pressure / temperature rating (ASME B16.5), flange and threaded connections, in °C and barg

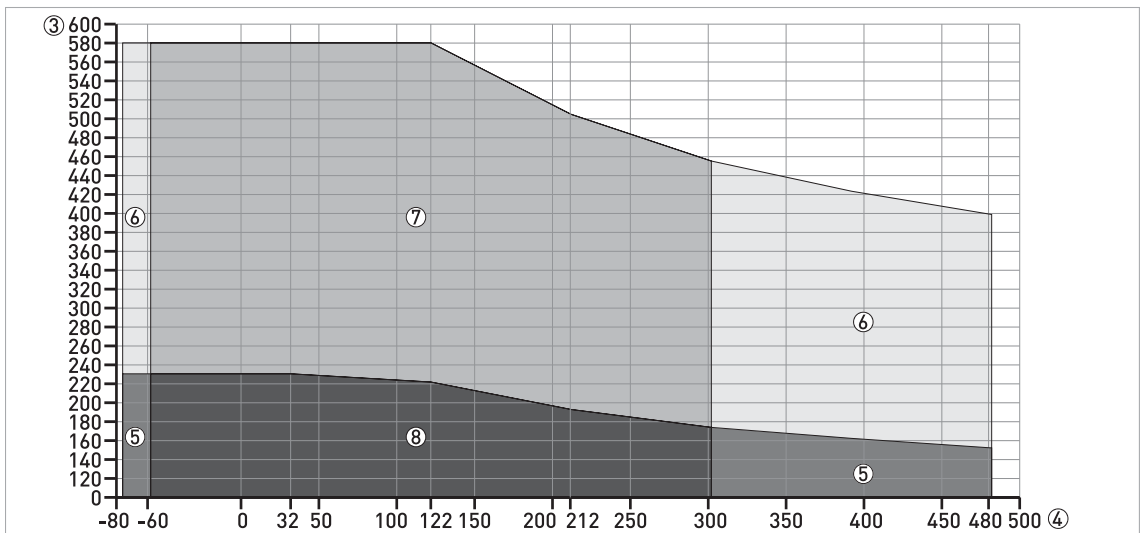

Figure 8-9: Pressure / temperature rating (ASME B16.5), flange and threaded connections, in °F and psig

- ① p [barg]
- ② T [°C]
- ③ p [psig]
- ④ T [°F]
- ⑤ Flange connection, Class 150: Metallic Horn and Wave Guide antennas
- ⑥ Flange connection, Class 300: Metallic Horn and Wave Guide antennas
- ⑦ Flange connection, Class 300: Metallic Horn and Wave Guide and PTFE Wave Horn antennas
- ⑧ Flange connection, Class 150: Metallic Horn and Wave Guide and PTFE Wave Horn antennas



INFORMATION!
CRN CERTIFICATION

There is a CRN certification option for devices with process connections that agree with ASME standards. This certification is necessary for all devices that are installed on a pressure vessel and used in Canada.

ASME flanges for CRN-approved devices: Metallic Horn, Wave Guide and PTFE Wave Horn antennas

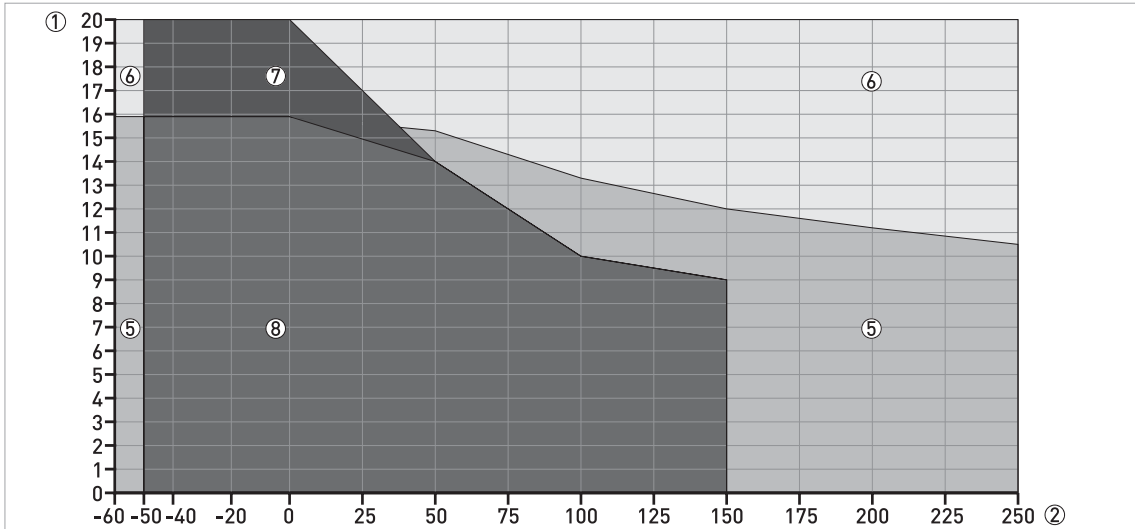

Figure 8-10: Pressure / temperature rating (ASME B16.5), flange and threaded connections, in °C and barg

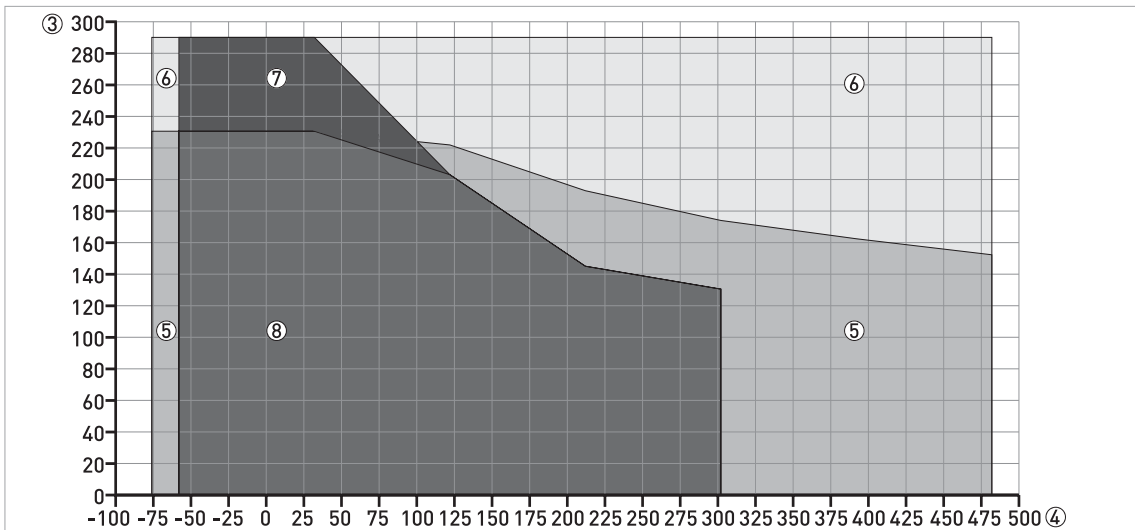

Figure 8-11: Pressure / temperature rating (ASME B16.5), flange and threaded connections, in °F and psig

- ① p [barg]
- ② T [°C]
- ③ p [psig]
- ④ T [°F]
- ⑤ Flange connection, Class 150: Metallic Horn and Wave Guide antennas
- ⑥ Flange connection, Class 300: Metallic Horn and Wave Guide antennas
- ⑦ Flange connection, Class 300: Metallic Horn and Wave Guide and PTFE Wave Horn antennas
- ⑧ Flange connection, Class 150: Metallic Horn and Wave Guide and PTFE Wave Horn antennas

ASME threaded connections: PP Wave Horn antenna

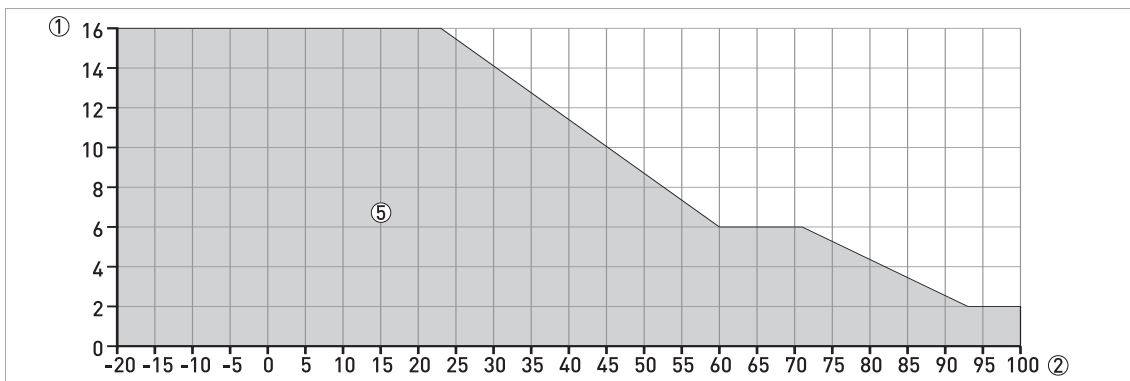

Figure 8-12: Pressure / temperature rating (ASME B1.20.1), threaded connection, in °C and barg

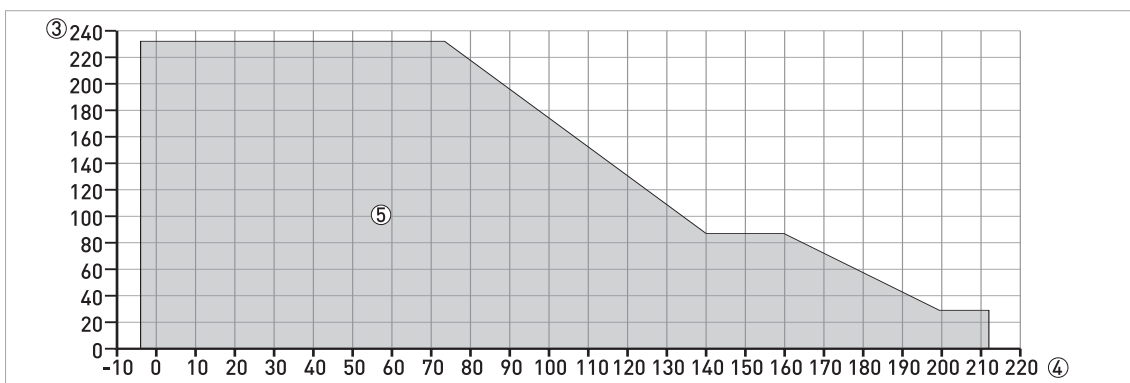

Figure 8-13: Pressure / temperature rating (ASME B1.20.1), threaded connection, in °F and psig

- ① p [barg]
- ② T [°C]
- ③ p [psig]
- ④ T [°F]
- ⑤ Threaded connection, NPT (ASME B1.20.1): PP Wave Horn antenna



INFORMATION!
CRN CERTIFICATION

There is a CRN certification option for devices with process connections that agree with ASME standards. This certification is necessary for all devices that are installed on a pressure vessel and used in Canada.

ASME threaded connections for CRN-approved devices: PP Wave Horn antenna

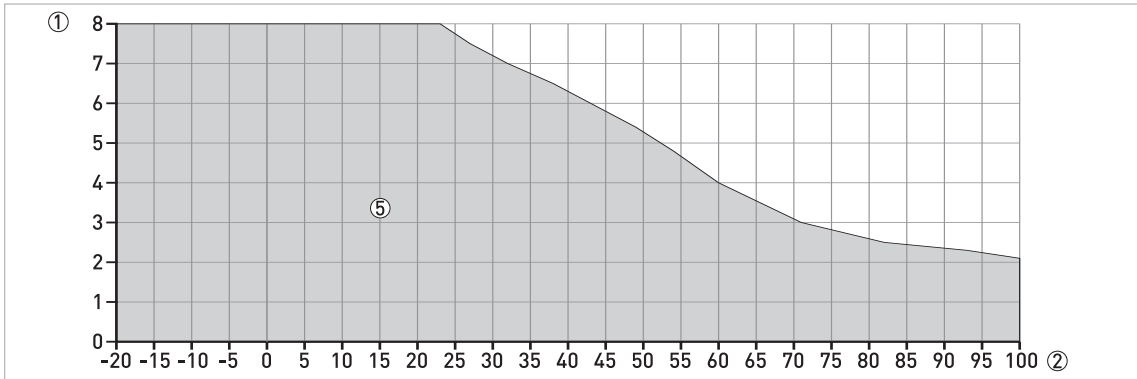

Figure 8-14: Pressure / temperature rating (ASME B1.20.1), threaded connection, in °C and barg

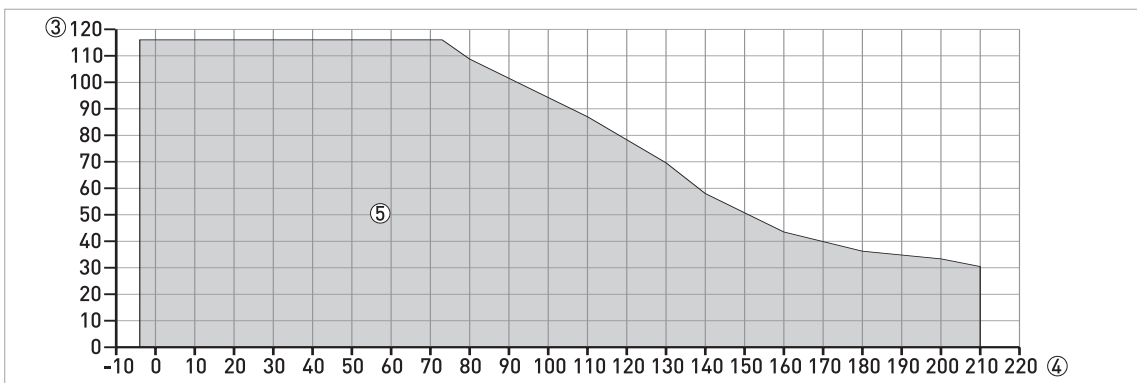

Figure 8-15: Pressure / temperature rating (ASME B1.20.1), threaded connection, in °F and psig

- ① p [barg]
- ② T [°C]
- ③ p [psig]
- ④ T [°F]
- ⑤ Threaded connection, NPT (ASME B1.20.1): PP Wave Horn antenna

8.5 Antenna selection

The graphs below show which antenna to select for the application based on:

- D, the measuring range,
- ϵ_r , is the dielectric constant of the product being measured

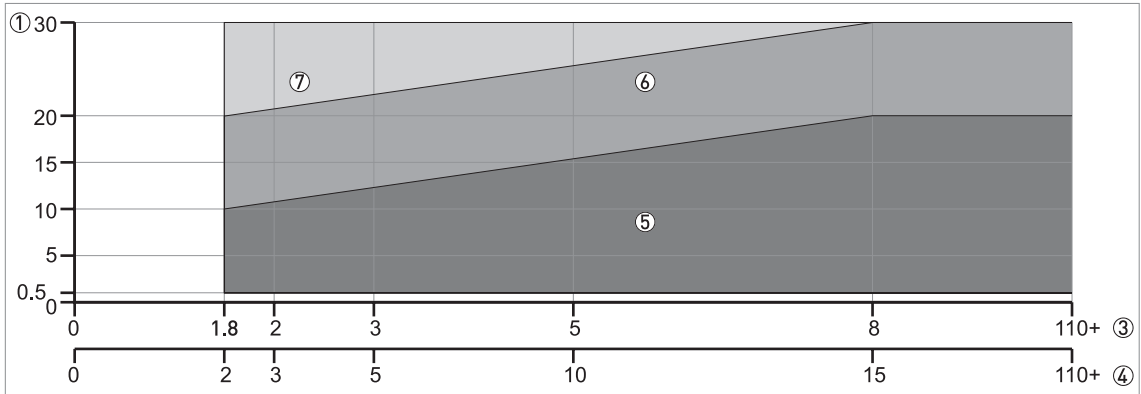

Figure 8-16: Selection of antenna (graph of distance in m against ϵ_r)

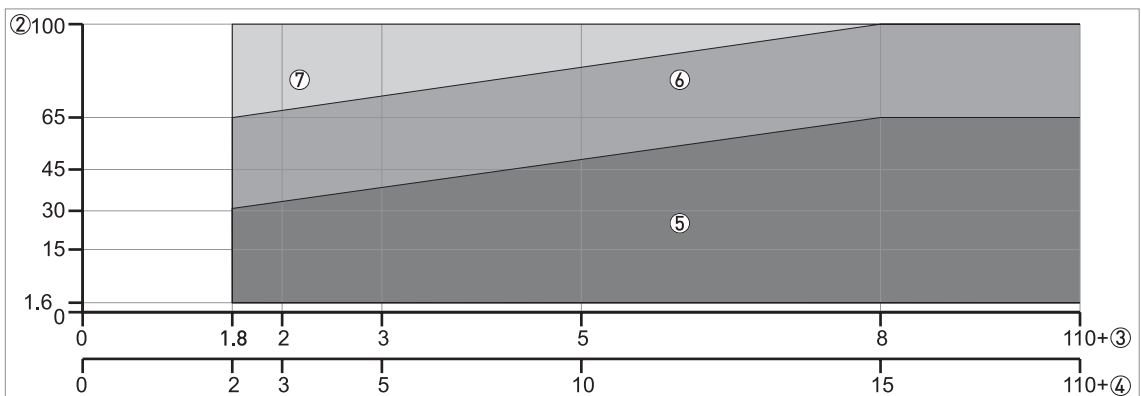

Figure 8-17: Selection of antenna (graph of distance in ft against ϵ_r)

- ① Tank height / Measuring range [m]
- ② Tank height / Measuring range [ft]
- ③ ϵ_r for storage tanks with smooth product surface
- ④ ϵ_r for process tanks without agitator or foam
- ⑤ All antennas:
 - DN80/3" and DN100/4" Metallic Horn antenna: only for use in a stilling well*
 - Wave Guide antenna: maximum measuring range is 6 m / 19.68 ft
- ⑥ DN150/6" or DN200/8" Metallic Horn antennas in a stilling well* or DN200/8" Metallic Horn antenna
- ⑦ DN200/8" Metallic Horn antenna in a stilling well*

* A stilling well is equivalent to the Wave Guide antenna option or a bypass chamber

8.6 Dimensions and weights

Housing, process connection and antenna options

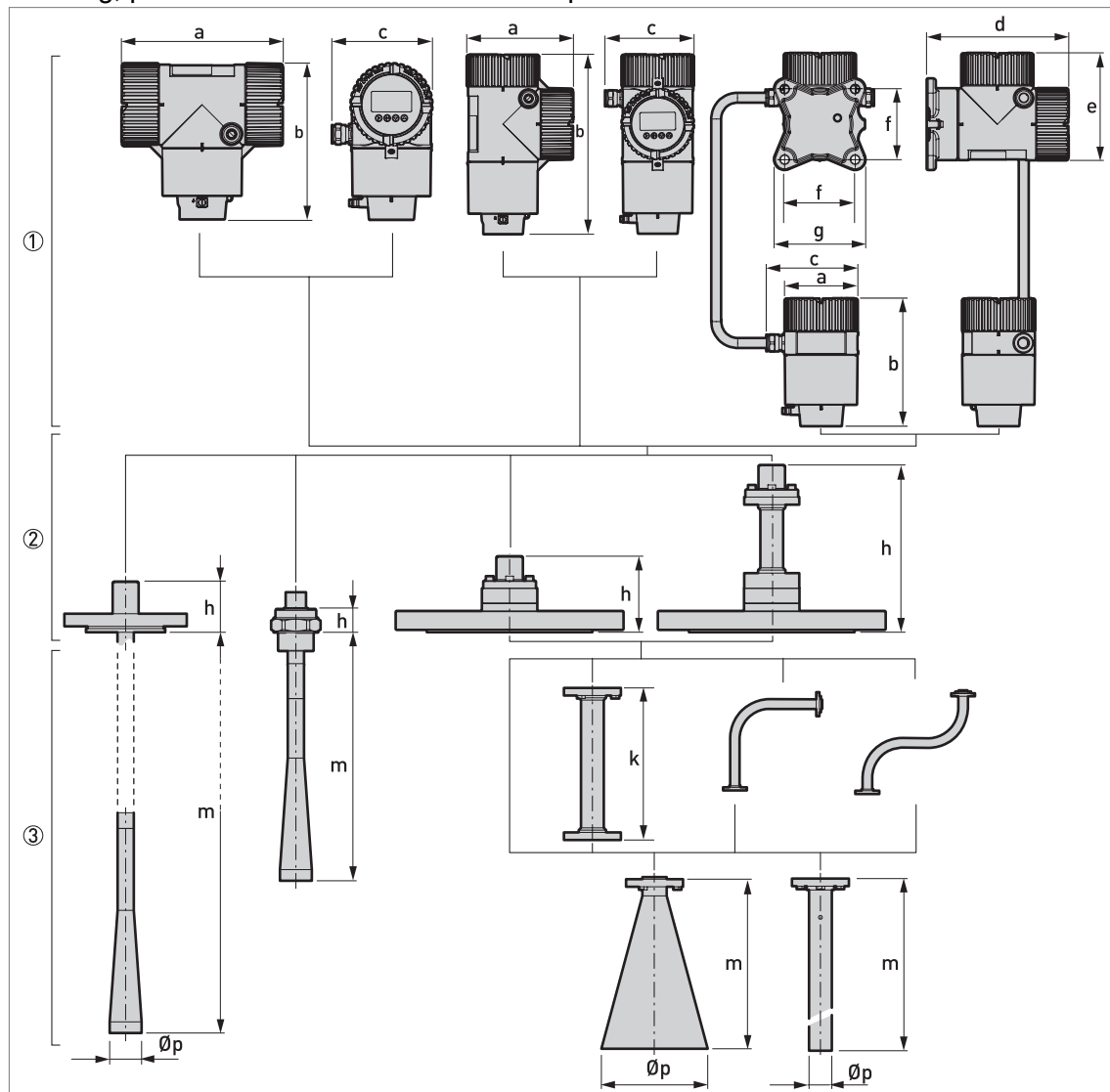

Figure 8-18: Housing, process connection and antenna options

- ① **Housing options.** From left to right: compact converter with horizontal housing, compact converter with vertical housing, and remote converter (top) and antenna housing (bottom)
- ② **Process connection options.** From left to right: flange connection for PTFE Wave Horn antenna, threaded connection for PP Wave Horn antenna, flange connection for Metallic Horn and Wave Guide antennas, flange connection with a high-temperature (HT) extension for Metallic Horn and Wave Guide antennas
- ③ **Antenna options.** From left to right: PTFE Wave Horn antenna, PP Wave Horn antenna, Metallic Horn antenna (with or without an antenna extension option: straight, "L" or "S" extension), Wave Guide antenna

**INFORMATION!**

All housing covers have bayonet connectors unless it is an explosion-proof (XP / Ex d-approved) device. The terminal compartment cover for explosion-proof devices has a thread with a flame path.

Housing options: Dimensions in mm and inches

Dimensions	Compact - horizontal		Compact - vertical		Remote	
	Non-Ex or Ex i (Ex d)		Non-Ex or Ex i (Ex d)		Non-Ex or Ex i (Ex d)	
	[mm]	[inches]	[mm]	[inches]	[mm]	[inches]
a	205 (265)	8.07 (10.43)	155 (212)	6.10 (8.35)	106 (106)	4.17 (4.17)
b	216 (216)	8.50 (8.50)	265 (265)	10.43 (10.43)	188 (188)	7.40 (7.40)
c	130 (130)	5.12 (5.12)	130 (130)	5.12 (5.12)	130 (130)	5.12 (5.12)
d	-	-	-	-	202 (202)	7.95 (7.95)
e	-	-	-	-	155 (218)	6.10 (8.58)
f	-	-	-	-	100 (100)	3.94 (3.94)
g	-	-	-	-	130 (130)	5.12 (5.12)

Process connection and antenna options: Dimensions in mm

Dimensions [mm]	PTFE Wave Horn	PP Wave Horn	Metallic Horn				Wave Guide
			DN80 / 3"	DN100 / 4"	DN150 / 6"	DN200 / 8"	
h	68	33	100 (220 for the HT extension) ①				
k	-	-	100, 200, 300, 400, 500, 1000 ②				
m	296 ③	322	112	148.5	223	335	1000...6000
Øp	43	43	80	100	140	200	30

① The HT extension is only for Metallic Horn and Wave Guide antennas. It is attached between the signal converter and the flange if the process connection temperature is +150...+250°C.

② These are the length options for the straight antenna extension. For data about the dimensions of "S" and "L" extensions, refer to the illustrations that follow.

③ Other antenna lengths are available: 396, 496 or 596 mm. These options are for tanks with long nozzles.

Process connection and antenna options: Dimensions in inches

Dimensions [inches]	PTFE Wave Horn	PP Wave Horn	Metallic Horn				Wave Guide
			DN80 / 3"	DN100 / 4"	DN150 / 6"	DN200 / 8"	
h	2.68	1.30	3.94 (8.66 for the HT extension) ①				
k	-	-	3.94, 7.87, 11.81, 15.75, 19.68 or 39.37 ②				
m	11.65 ③	12.68	4.41	5.85	8.78	13.19	39.4...236.2
Øp	1.69	1.69	3.15	3.94	5.51	7.87	1.18

① The HT extension is only for Metallic Horn and Wave Guide antennas. It is attached between the signal converter and the flange if the process connection temperature is +302...+482°F.

② These are the length options for the straight antenna extension. For data about the dimensions of "S" and "L" extensions, refer to the illustrations that follow.

③ Other antenna lengths are available: 15.59", 19.53" or 23.46". These options are for tanks with long nozzles.

Special antenna extensions for tanks with obstructions (DN150 / 6" and DN200 / 8" Metallic Horn antenna options only)

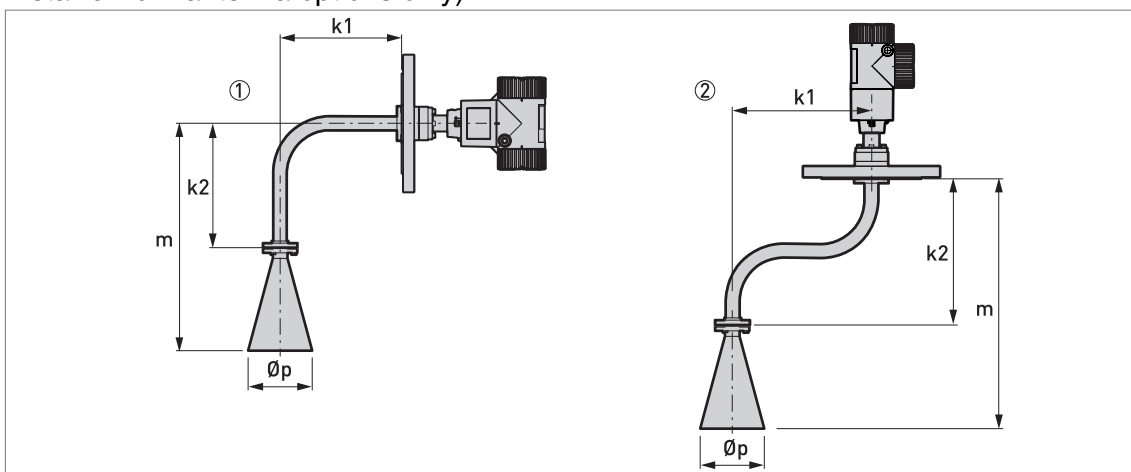

Figure 8-19: Special antenna extensions for tanks with obstructions (DN150 / 6" and DN200 / 8" Metallic Horn antenna options only)

- ① "L" (right angle) antenna extension
- ② "S" antenna extension

Special antenna extensions: Dimensions in mm

Dimensions [mm]	Metallic Horn antenna			
	With "L" (right angle) extension		With "S" extension	
	DN150 / 6"	DN200 / 8"	DN150 / 6"	DN200 / 8"
k1	271		300	
k2	271		322	
m	494	606	545	657
Øp	140	200	140	200

Special antenna extensions: Dimensions in inches

Dimensions [inches]	Metallic Horn antenna			
	With "L" (right angle) extension		With "S" extension	
	DN150 / 6"	DN200 / 8"	DN150 / 6"	DN200 / 8"
k1	10.67		11.81	
k2	10.67		12.68	
m	19.45	23.86	21.46	25.87
Øp	5.51	7.87	5.51	7.87

Purging and heating/cooling system options

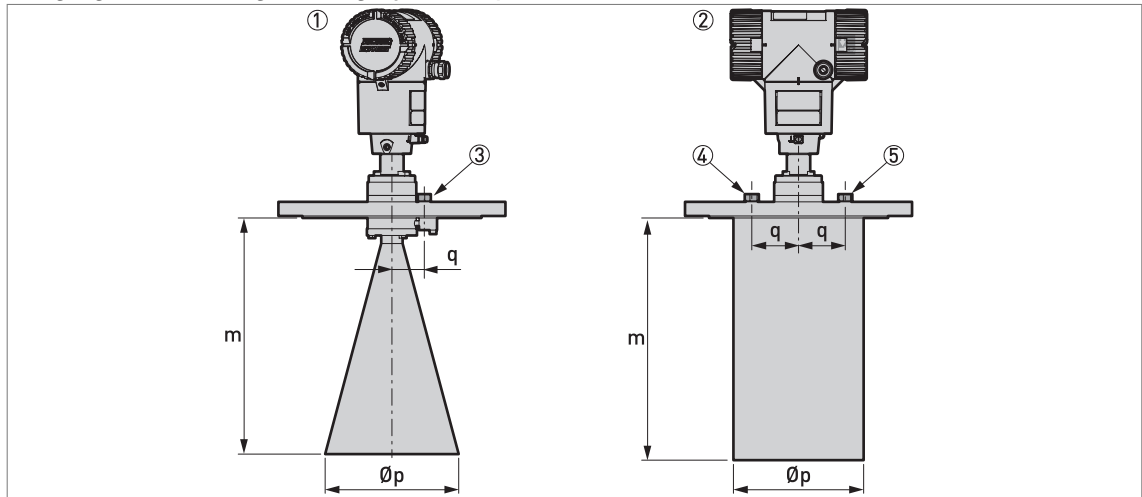

Figure 8-20: Purging and heating/cooling system options

- ① Flange connection with purging option
- ② Flange connection with heating/cooling system option
- ③ G 1/4 threaded connection for purging system (the plug is supplied by the manufacturer)
- ④ G 1/4 threaded connection for the heating/cooling system outlet (the plug is supplied by the manufacturer)
- ⑤ G 1/4 threaded connection for the heating/cooling system inlet (the plug is supplied by the manufacturer)

Purging system and heating/cooling system: Dimensions in mm

Dimensions [mm]	Metallic Horn antenna			
	Purging system		Heating/cooling system	
	DN150 / 6"	DN200 / 8"	DN150 / 6"	DN200 / 8"
m	223	351	202	360 ①
Øp	140	200	139.7	195
q	34	34	53	70

① This is the standard length. Longer on request.

Purging system and heating/cooling system: Dimensions in inches

Dimensions [inches]	Metallic Horn antenna			
	Purging system		Heating/cooling system	
	DN150 / 6"	DN200 / 8"	DN150 / 6"	DN200 / 8"
m	8.78	13.82	8.0	14.17 ①
Øp	5.51	7.87	5.5	7.68
q	1.34	1.34	2.1	2.76

① This is the standard length. Longer on request.



INFORMATION!

All wetted parts (flange, antenna and heating/cooling jacket) of the heating/cooling system option are made of 316Ti / 1.4571.

Weather protection option

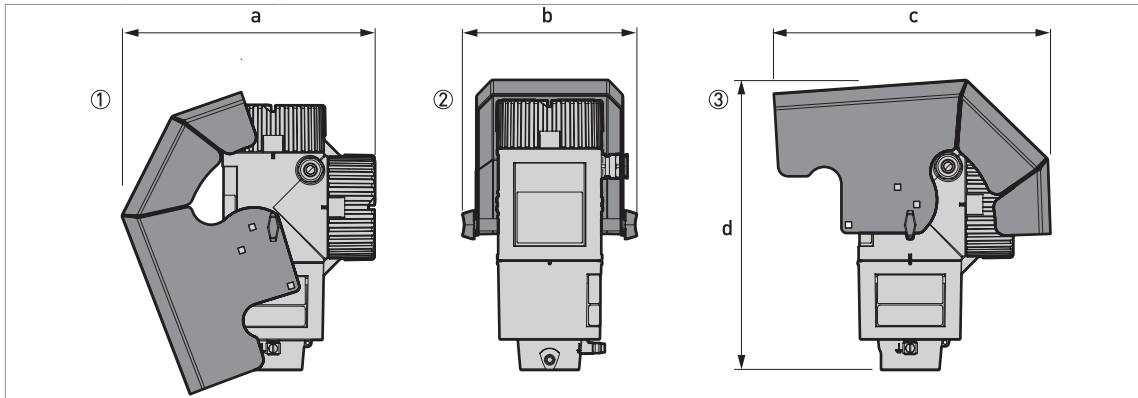

Figure 8-21: Weather protection option for Compact / Vertical and Remote versions

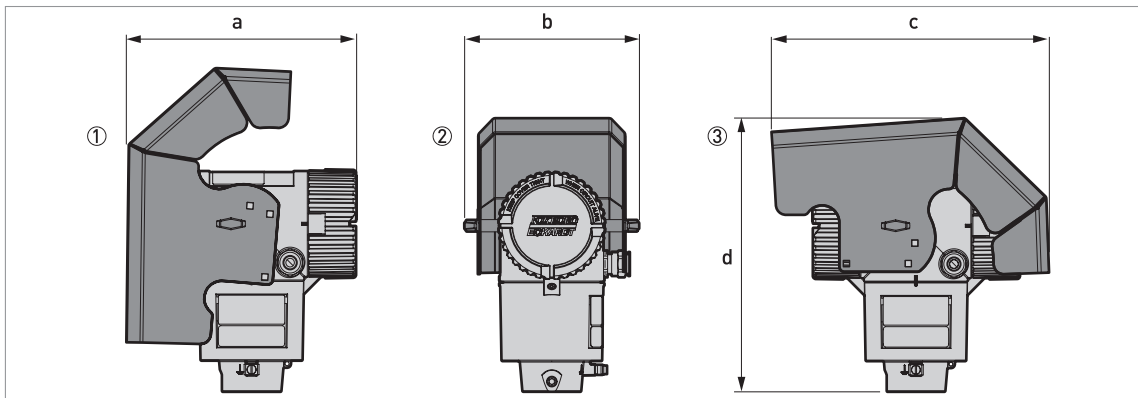

Figure 8-22: Weather protection option for Compact / Horizontal and Remote versions

- ① Left side (with weather protection open)
- ② Rear view (with weather protection closed)
- ③ Right side (with weather protection closed)

Dimensions and weights in mm and kg

Weather protection	Dimensions [mm]				Weights [kg]
	a	b	c	d	
Compact / Vertical or Remote versions	251	170	274	285	1.6
Compact / Horizontal or Remote versions	228	170	274	269	1.6

Dimensions and weights in inches and lb

Weather protection	Dimensions [inches]				Weights [lb]
	a	b	c	d	
Compact / Vertical or Remote versions	9.9	6.7	10.8	11.22	3.5
Compact / Horizontal or Remote versions	9.0	6.7	10.8	10.59	3.5

Converter and antenna housing weights

Type of housing	Weights			
	Aluminium housing		Stainless steel housing	
	[kg]	[lb]	[kg]	[lb]

Non-Ex / intrinsically-safe (Ex i / IS)

Compact				
Remote converter ①	2.5	5.5	5.9	13.0
Antenna housing ①	2.0	4.4	4.1	9.0

Explosion proof (Ex d / XP)

Compact				
Remote converter ①	2.9	6.40	7.1	15.65
Antenna housing ①	2.0	4.4	4.1	9.0

① The remote version of the device has a "remote converter" and an "antenna housing". For more data, refer to "Housing dimensions" at the start of this section.

Antenna option weights

Antenna options	Min./Max. weights	
	[kg]	[lb]

Standard options, without converter

PTFE Wave Horn antenna with flange connection	3.7	8.2
PTFE Wave Horn antenna with flange connection, with 100 mm antenna extension	3.78	8.3
PTFE Wave Horn antenna with flange connection, with 200 mm antenna extension	3.86	8.5
PTFE Wave Horn antenna with flange connection, with 300 mm antenna extension	3.94	8.7
PP Wave Horn antenna with threaded connection	0.7	1.5
DN80 / 3" Metallic Horn antenna with flange connection, standard length	5.6...37.1	12.3...81.8
DN100 / 4" Metallic Horn antenna with flange connection, standard length	9.1...37.2	20.1...82
DN150 / 6" Metallic Horn antenna with flange connection, standard length	13.6...37.5	30...82.7
DN200 / 8" Metallic Horn antenna with flange connection, standard length	14.0...37.8	30.9...83.3
Wave Guide antenna with flange connection, 1...6 m / 3.28...19.68 ft	1.6...9.9	3.5...21.8

Antenna extension options

Straight extension, length 100 mm ①	+0.76	+1.68
Straight extension, length 200 mm ①	+0.94	+2.07
Straight extension, length 300 mm ①	+1.12	+2.47
Straight extension, length 400 mm ①	+1.30	+2.87
Straight extension, length 500 mm ①	+1.48	+3.26
Straight extension, length 1000 mm ①	+2.38	+5.25
"S" extension ①	+1.56	+3.44
"L" (right-angle) extension ①	+1.48	+3.26

Antenna options	Min./Max. weights	
	[kg]	[lb]

Other options

HT extension ②	+0.98	+2.16
----------------	-------	-------

① This option is for Metallic Horn and Wave Guide antenna options

② This component is only for the Metallic Horn and Wave Guide antennas. It is attached between the signal converter and the flange if the process connection temperature is +150...+250°C / +302...+482°F.

9 Description of HART interface

9.1 General description

The HART[®] Protocol is an open digital communication protocol for industry. It is free to use by anyone. It is included in the software embedded in signal converters of HART-compatible devices.

There are 2 classes of devices which support the HART[®] Protocol: operating devices and field devices. There are 2 classes of operating devices (Master): PC-supported workstations (Primary Master) and manual control units (Secondary Master). These can be used in control centres and other locations. HART[®] field devices include sensors, converters and actuators. Field devices include 2-wire and 4-wire devices, and also intrinsically-safe versions for use in hazardous areas.

There are 2 primary operation modes for HART-compatible devices: point-to-point mode and multi-drop mode.

If the device is used in point-to-point mode, the HART[®] Protocol uses the Bell 202 Frequency Shift Keying (FSK) standard to put a digital signal on top of the 4...20 mA signal. The connected device sends and receives digital signals that agree with the HART[®] Protocol, and sends analog signals at the same time. Only 1 device can be connected to the signal cable.

If the device is used in multi-drop mode, the network only uses a digital signal that agrees with the HART[®] Protocol. The loop current is set to 4 mA. You can connect a maximum of 15 devices to the signal cable.

An FSK or HART[®] modem is included in field devices and manual control units. It is necessary to have an external modem for PC-supported workstations. The external modem is connected to the serial interface.

9.2 Software description

HART[®] identification codes and revision numbers

Manufacturer ID:	0x45
Device:	
Device Revision:	1
DD Revision	1
HART [®] Universal Revision:	6
FC 375/475 system SW.Rev.:	≥ 2.0
AMS version:	≥ 7.0
PDM version:	≥ 6.0
FDT version:	1.2

9.3 Connection variants

The signal converter is a 2-wire device with 4...20 mA current output and HART[®] interface.

- **Multi-Drop Mode is supported**
In a Multi-Drop communication system, more than 1 device is connected to a common transmission cable.
- **Burst Mode is not supported**

There are two ways of using the HART[®] communication:

- as Point-to-Point connection and
- as Multi-Drop connection with 2-wire connection.

9.3.1 Point-to-Point connection - analogue / digital mode

Point-to-Point connection between the signal converter and the HART[®] Master.

The current output of the device is passive.

Also refer to *Point-to-point connection* on page 50.

9.3.2 Multi-Drop connection (2-wire connection)

Up to 15 devices may be installed in parallel (this signal converter and other HART[®] devices).

For an illustration of multi-drop networks, refer to *Multi-drop networks* on page 51.

For data on communication in multi-drop mode, refer to *HART[®] network configuration* on page 75.

9.4 HART[®] device variables

The HART[®] dynamic variables PV (Primary Variable), SV (Secondary Variable), TV (Third Variable) and 4V (Fourth Variable) can be assigned to any of the device variables.

The HART[®] dynamic variable PV is always connected to the HART[®] current output which is, for example, assigned to level measurement.

9.5 Field Communicator 375/475 (FC 375/475)

The Field Communicator is a hand terminal from Emerson Process Management that is designed to configure HART® and Foundation Fieldbus devices. Device Descriptions (DDs) are used to integrate different devices into the Field Communicator.

9.5.1 Installation



CAUTION!

The Field Communicator cannot be used to correctly configure, operate or read data from the device unless the Device Description (DD) file is installed.

System and software requirements for the Field Communicator

- System card that includes the "Easy Upgrade Option"
- Field Communicator Easy Upgrade Programming Utility
- HART® Device Description file

For more data, refer to the Field Communicator User's Manual.

9.5.2 Operation



INFORMATION!

The Field Communicator will not give you access to the service menu. A simulation is only possible for current outputs.

The Field Communicator and the device's local display use almost the same procedures to operate the signal converter. The online help for each menu item refers to the function number given to each menu item on the local device display. Protection of settings is the same as on the device's local display.

The Field Communicator always saves a complete configuration for communication with AMS.

For more data, refer to *HART®* menu tree for Basic-DD on page 120.

9.6 Asset Management Solutions (AMS)

The Asset Management Solutions Device Manager (AMS) is a PC program from Emerson Process Management which is designed to configure and manage HART®, PROFIBUS and Foundation-Fieldbus devices. Device Descriptions (DDs) are used to integrate different devices into the AMS.

9.6.1 Installation

Please read the README.TXT file in the Installation Kit.

If the Device Description has not been installed at this time, install the Installation Kit HART® AMS. This .EXE file can be downloaded from our website.

For installation data, refer to the "AMS Intelligent Device Manager Books Online" section "Basic AMS Functionality > Device Configurations > Installing Device Types > Procedures > Install device types from media".

9.6.2 Operation



INFORMATION!

For more data, refer to HART® menu tree for AMS on page 122.

9.6.3 Parameter for the basic configuration

Due to AMS requirements and conventions, there are differences when operating the signal converter with AMS and operating using the local keyboard. The service menu parameters are not supported and simulation is only possible for current outputs. The online help for each parameter contains its function number as a reference to the local device display.

9.7 Field Device Tool / Device Type Manager (FDT / DTM)

A Field Device Tool Container (FDT Container) is a PC program used to configure HART®, PROFIBUS and Foundation Fieldbus devices. To configure a device, an FDT container uses the applicable Device Type Manager (DTM).

9.7.1 Installation

Before you operate the device, the Device Type Manager (Device DTM) must be installed in the Field Device Tool Container. This .msi file can be downloaded from our website. For installation and configuration data, refer to the documentation that is supplied in the "Downloads" section of the website.

9.7.2 Operation

The DTM and the device's local display use almost the same procedures to operate the signal converter. For more data, refer to *Operation* on page 58.

9.8 Process Device Manager (PDM)

The Process Device Manager (PDM) is a Siemens PC program designed to configure HART® and PROFIBUS devices. Device Descriptions (DDs) are used to integrate different devices into the PDM.

9.8.1 Installation

Install Device Description files supplied in the Device Install HART® PDM folder. This is necessary for each type of field device that is used with SIMATIC PDM. This folder is available for download from the website or on the DVD-ROM supplied with the device.

If you use PDM version 5.2, refer to PDM manual, section 11.1 - Install device / Integrate device into SIMATIC PDM with Device Install.

If you use PDM version 6.0, refer to PDM manual, section 13 - Integrating devices.

For more data, refer to "readme.txt". You can find this file in the Installation Kit.

9.8.2 Operation



INFORMATION!

For more data, refer to HART® menu tree for PDM on page 124.

There can be differences between the names of menus in the SIMATIC PDM software tool and menus shown on the device display screen. Refer to the online help in SIMATIC PDM to find the function number of each menu item. This function number agrees with the function number in the device menus.

Use the same procedure for the protection of parameters in the supervisor menu.

9.9 HART[®] menu tree for Basic-DD

Abbreviations of the following tables:

- ^{Opt} Optional, depending on device version and configuration
- Rd Read only
- ^{Cust} Custody lock protection
- ^{Loc} Local, affects only DD host views

9.9.1 Overview Basic-DD menu tree (positions in menu tree)

1 Measurements	1 Measurements	
	2 Outputs	
2 Configuration and Test	1 Info.	1 Identification
		2 Output
	2 Supervisor	1 Test
		2 Basis Parameters
		3 Signal Out
		4 Application
		5 Display
6 Conversion Table		
7 Reset		
3 Diag/Service	1 Status	1 Standard Status
		2 Device-specific Status
4 Access Rights	1 Access level	
	2 Method Login	
	3 Method entry Code	
5 HART variables		

9.9.2 Basic-DD menu tree (details for settings)

1 Measurements

1 Measurements	1 Level value Rd / 2 Distance value Rd / 3 Volume value Rd / 4 Ullage value Rd / 5 Reflection value Rd
2 Inputs/Outputs	1 PV Rd / 2 PV Loop Current Rd / 3 PV % rnge Rd

2 Configuration and Test

1 Info.	1 Identification	1 Serial Number Rd / 2 Converter Firmware Version Rd / 3 Sensor Firmware Version Rd / 4 HMI Firmware Version Rd
	2 Output	1 Function I Rd / 2 Output Range Rd / 3 PV URV Rd / 4 PV LRV Rd / 5 Output Error Delay Rd
2 Supervisor	1 Test	1 Test I
	2 Basis Parameters	1 Tank Height / 2 Blocking Distance / 3 Time Constant / 4 Pipe Enabled / 5 Pipe Diameter / 6 Pipe Height / 7 Antenna Extension / 8 Antenna Type / 9 Distance Piece / 15 Length Unit (HART) / 16 Volume Unit (HART)
	3 Signal Out	1 Function I / 2 PV LRV / 3 PV URV / 4 Output Range / 5 Output Error Delay / 6 Current Ouput Calibration ^{Cust}
	4 Application	1 Tank Type / 2 Tracking Velocity / 3 Epsilon R Product / 4 Measuring Mode / 5 Overfill Detection / 6 Multiple Reflection / 7 Empty Spectrum / 8 Record Empty Spectrum
	5 Display	1 Language / 2 Display Length Unit / 3 Display Volume Unit
	6 Conversion Table	1 Input table / 2 Delete table
	7 Reset	1 Warm start / 2 Factory reset / 3 Reset Configuration Changed flag

3 Diag/Service

1 Status	1 Standard status	1 Device status Rd / 2 Write protect Rd	
	2 Device-specific status	1 Device failures	1 Error Rd / 2 Error Rd / 3 Error Rd
		2 Device warning maintenance required	1 Warning Rd
		3 Device warning out of specification	1 Warning Rd
		4 Info	1 Info Rd

4 Access Rights

1 Access Level	(Access Not Granted)
2 Method Login	1 No Access (Log Out) / 2 Supervisor (Normal User) / 3 Service
3 Method Entry Code	

5 HART variables

	1 Poll addr / 2 Tag / 3 Hardware rev Rd / 4 Software rev Rd / 5 Descriptor / 6 Date / 7 Message / 8 Manufacturer Rd / 9 Model Rd / Dev id Rd / Universal id Rd / FId dev rev Rd / Num req preams Rd / Num resp preams Rd / Write protect Rd / Production number Rd / Final asmbly num Rd / PV is / SV is / TV is / QV is
--	--

9.10 HART[®] menu tree for AMS

Abbreviations of the following tables:

- ^{Opt} Optional, depending on device version and configuration
- Rd Read only
- ^{Cust} Custody lock protection
- ^{Loc} Local AMS, affects only AMS views

9.10.1 Overview AMS menu tree (positions in menu tree)

Process variables	Measurements	
	Analog Output	
Device Diagnostics	Overview	
	Fatal Errors (Failure)	
	Warnings (Maintenance required)	
	Warnings (Out of specifications)	
	Warnings (Function check)	
Methods	Access Right	
	Tests	
	Calibrate	
	Empty Spectrum	
	Conversion Table	
	Master reset	
Configure / Setup	Basic Setup	Basic Parameters
		Local Display
		Application
	Analog Output	Output Functions
		Output 1
	Units	
	Device	
	HART	ID
		-
	Conversion table	

9.10.2 AMS menu tree (details for settings)

Process Variables

Measurements	Level Rd / Distance Rd / Volume/Mass/Flow Rd / Ullage Volume/Mass/Flow Rd / Reflection Rd
Primary Output	Function I / Loop current Rd / PV Percent of Range Rd

Device Diagnostics

Overview	Primary variable out of limits / Non-primary variable out of limits / Primary variable analog output saturated / Primary variable analog output fixed / Cold Start / Configuration changed / Field device malfunction
Fatal Errors (Failure)	Converter EEPROM error / Converter RAM error / Converter ROM error / Sensor EEPROM error / Sensor RAM error / Sensor ROM error / Current output drift / Sensor Microwave error / Converter Voltage error / Sensor Voltage error / Internal Comm. error / Temperat. out of range / Sensor not compatible / Sensor no signal / Sensor processing failure / Peak lost error / Overfill error
Warnings (Maintenance required)	Empty spectrum invalid / Signal weak / Signal strong / Bad Measurement Quality / Temperature < -35°C / Temperature > +75°C
Warnings (Out of specification)	Peak lost / Overfill / Temperature out of range
Warnings (Function check)	Local operation on the device
Information	Spectrum quality bad / Peak lost in tank bottom / Temperature out of range for HMI

Methods

Acess right	Log In/Log Out / Password Yes/No
Tests	Test Output I
Calibrate	D/A Trim
Empty Spectrum	Empty Spec. Rec.
Conversion Table	Input table / Delete table
Reset	Restart Device / Reset Factory / Rst Conf. Chged flag

Configure / Setup

Basic Setup	Basic Parameters	Tank Height / Blocking Distance / Time Constant / Stillwell Enabled / Stillwell Diameter / Stillwell Height / Antenna Extension / Antenna Type / Distance Piece / Tag
	Local Display	Display length unit / Display volume unit / Language
	Application	Tank Type / Tracking velocity / Epsilon R product / Measuring Mode / Overfill Detection / Multiple Detection / Empty Spectrum On/Off
Analog Output	Output Functions	Function I / SV / TV / QV
	Output 1	Output Range / Output Error Delay / LRV / URV
Units	Length unit (HART) / Volume unit (HART) / Time constant	
Device	Model / Manufacturer / Fld dev rev / Software rev / Write protect / Interface option Rd / Descriptor / Message / Date / Serial number / Converter firmware number / Sensor Firmware number / HMI Firmware number	
HART	ID	Tag / Polling address / Device ID
		Universal revision / Fld dev rev Num / Num request preams
Conversion table	Number of points / Length unit Rd / Conversion unit Rd / Points (1...30 level-conversion pairs)	

9.11 HART[®] menu tree for PDM

Abbreviations of the following tables:

- ^{Opt} Optional, depending on device version and configuration
- Rd Read only
- ^{Cust} Custody lock protection
- ^{Loc} Local PDM, affects only PDM views

9.11.1 Overview PDM menu tree (positions in menu tree)

Overview: Menu Device

Communication Path
Download To Device...
Upload To PG/PC...
Update Diagnosis Status
Configuration and Test
Access Rights
watch status

Overview: Menu View

Measurements	Level Value
	Distance Value
	Ullage Value
	Reflection Value
Yt diagram	
Diag / Service	
Toolbar	
Status Bar	
Update	

Overview: PDM parameters

Configuration and Test	Info.	Identification
		Output
	Supervisor	Test
		Basic Parameters
		Signal Output
		Application
		Display
		Conversion Table
Reset		
Access rights		
HART variables		

9.11.2 PDM menu tree (details for settings)

Device Menu

Communication Path

Download To Device...

Upload To PG/PC...

Update Diagnosis Status

Configuration and Test

Info.	Identification	Serial Number Rd / Converter Firmware version Rd / Sensor Firmware version Rd / HMI Firmware version Rd
	Output	Function I Rd / Output Range Rd / PV URV Rd / PV LRV Rd / Output Error Delay Rd
Supervisor	Test	Test I
	Basic Parameters	Tank Height / Blocking Distance / Time Constant / Pipe Enable / Pipe Diameter / Pipe Height / Antenna Extension / Antenna Type / Distance Piece / Length Unit (HART) / Conversion Unit (HART)
	Signal Output	Function I / Output Range / PV URV / PV LRV / Output Error Delay / Current Output Calibration ①
	Application	Tank Type / Tracking Velocity / Epsilon R product / Measuring Mode / Overfill Detection / Multiple Reflection / Empty Spectrum Recording / Empty Spectrum On/Off
	Display	Language / Display Length Unit / Display Conversion Unit
	Conversion Table	Input Table / Delete Table
	Reset	Warm start (function to restart the device) / Factory Reset / Reset Configuration Changed Flag

Access rights

Access level Rd
Method Login
Method Entry Code

HART Variables

1 Poll addr / 2 Tag / 3 Hardware rev Rd / 4 Software rev Rd / 5 Descriptor / 6 Date / 7 Message / 8 Manufacturer Rd / 9 Model Rd / Dev id Rd / Universal id Rd / Fld dev rev Rd / Num req preams Rd / Num resp preams Rd / Write protect Rd / Production number Rd / Final asmbly num Rd / PV is / SV is / TV is / QV is
--

① Current Output Calibration is available only if the service password is used

View Menu

Measurements

Measurements	Level Value / Distance Value / Volume Value / Ullage Value / Reflection Value
Output	Level value / Loop curent / % Range

Yt diagram

Diag / Service

Standard Status	Device status	PV Analog Channel Saturated / Configuration changed
Device-specific status	Device failures	Sensor Microwave error / Current Output Drift / Sensor ROM error / Sensor RAM error / Sensor EEPROM error / Converter ROM error / Converter RAM error / Converter EEPROM error / Sensor No Signal / Sensor Not Compatible / Temperature Out of Range / Internal Communication Error / Sensor Voltage Error / Converter Voltage Error / Peak Lost Error / Overfill Error
	Device Warning (Maintenance Required)	Empty Spectrum Invalid / Signal Weak / Signal Strong / Bad Measurement Quality / Temperature Below -35°C / Temperature Above +75°C
	Device Warning (Out of Specification)	Overfill Warning / Peak Lost Warning / Temperature Out of Range Warning
	Info	First Start / Spectrum Quality Bad / Peak Lost in Tank Bottom / Temperature out of range for HMI

Toolbar

Status Bar

Update

10 Appendix

10.1 Glossary

D

Dead zone	Non-measurement zone.
Dielectric constant	An electrical property of the product to be measured used in Radar measurement. Also known as ϵ_r , DK and relative permittivity. Defines the strength of the wave reflected back to the device's signal converter.
Distance	The distance from the face of flange to the level (1 product) or the surface of the top product (2 or more products). See the diagrams at the end of this section.
DTM	Device Type Manager. A driver for use in the PACTware™ program. All data and functions of the device are included in it.

E

Electromagnetic compatibility	Defines how much a device influences or is influenced by other devices that generate electromagnetic fields during operation. Refer to European standard EN 61326-1 for further details.
--------------------------------------	--

F

FMCW	Frequency-modulated continuous-wave radar technology. The signal is continuously present, but the frequency is modulated, usually in successive linear ramps over time (frequency sweeps).
-------------	--

H

Hazardous area	An area with a potentially explosive atmosphere. Trained personnel can install and use a device in this area. The device must be ordered with the appropriate options. The device requires approvals (ATEX, IECEx, FM, CSA, NEPSI etc.) related to site specifications. You can find more data about hazardous areas in the Ex Manuals and Ex Certificates of Compliance.
Horn (cone) antenna	A common antenna for most applications. It is used for the controlled emission and collection of radar signals.

I

Interference signals	False radar reflections.
-----------------------------	--------------------------

L

Level	Height from the bottom of the tank (user-defined) to the surface of the top product (Tank height – distance). See the diagrams at the end of this section.
--------------	--

M

Mass	Total mass of tank contents.
-------------	------------------------------

O

Operators

Users who can choose how to display measurements. They cannot configure the device in supervisor mode.

P

PACTware™

Software that operates and configures field devices from a remote workstation. It is not necessary to use fieldbus software or programs developed by the manufacturer.

R

Radar reflection

Signal reflected from the surface of the tank contents.

S

Signal converter

A set of electronic components in the device that send the measurement signal through some signal filters. They identify and measure the level of the tank contents.

Supervisor

Users who can configure the device in supervisor mode. They cannot configure the device in service mode.

U

Ullage volume

Unfilled volume. See the diagrams at the end of this section.

V

Volume

Total volume of tank contents.

W

Wave-Guide antenna

An antenna that transmits the radar signal in tube of a constant diameter to the measured product.

Waveguide

A PTFE component that is used to guide the emitted radar waves correctly into the horn antenna.

Wave Horn antenna

A plastic-coated horn antenna for corrosive liquids. Plastic coating options include PTFE and PP.

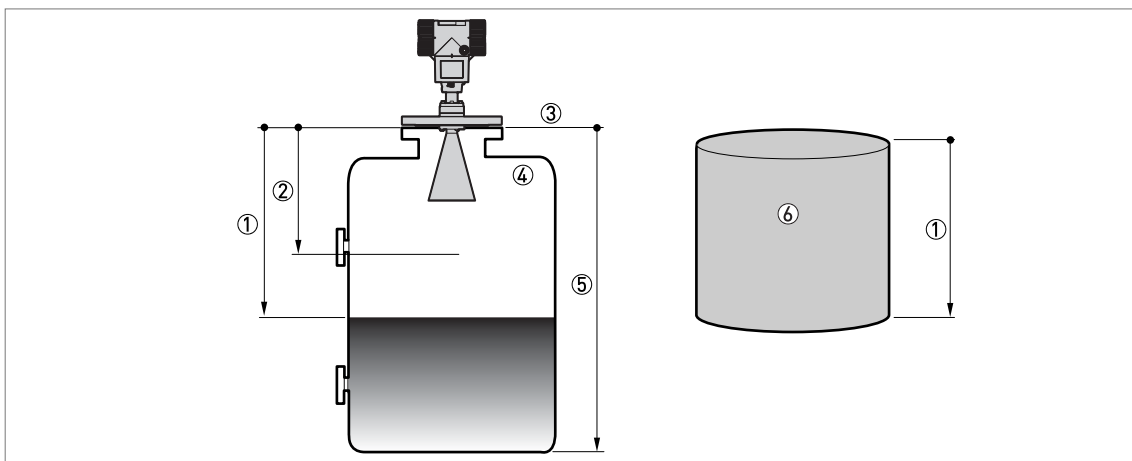

Figure 10-1: Measurement definitions: distance

- ① Distance
- ② Dead zone
- ③ Flange facing
- ④ Gas (Air)
- ⑤ Tank height
- ⑥ Ullage volume or mass

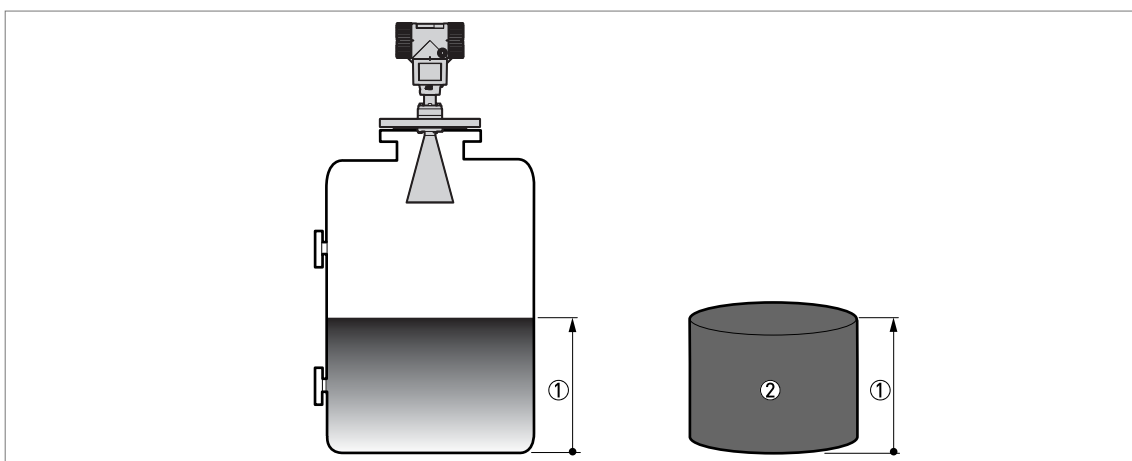

Figure 10-2: Measurement definitions: level

- ① Level
- ② Volume or mass

Product Specifications for Intelligent Level Transmitters

Product Specification: Device:

LevelWave Radar Transmitters

PSS EML3010	LG01	Guided Wave Radar Level Meter
PSS EML3020	LR01	Free-Space Radar Level Meter

LevelStar Buoyancy Transmitters

PSS EML0710	244LD	Intelligent Buoyancy Transmitter for Liquid Level, Interface and Density with Displacer and Torque Tube
PSS EML1710	244LVP	Intelligent Buoyancy Transmitter for Liquid Level, Interface and Density with Displacer
PSS EML0901	204xx	Accessories for Buoyancy Transmitters
PSS EMO0100		Accessories for Devices with HART-Protocol

Invensys, the Invensys logo, ArchestrA, Avantis, DolpHin, Esscor, Eurotherm, Foxboro Eckardt, Foxboro, I/A Series, Foxboro Evo, IMServ, InFusion, SimSci, Skelta, Triconex, and Wonderware are trademarks of Invensys plc, its subsidiaries or affiliates. All other brands and product names may be the trademarks or service marks of their representative owners.

© 2013 Invensys Systems, Inc. All rights are strictly reserved.

No part of the material protected by this copyright may be reproduced or utilized in any form or by any means, electronic or mechanical, including photocopying, recording, broadcasting, or by any information storage and retrieval system, other than for the purpose to act as an aid in operating the equipment to which the document relates without permission in writing from Invensys Systems, Inc. Invensys pursues a policy of continuous development and product improvement. The specifications, and terms within this document may therefore be changed without notice. The information in this document is given in good faith, but is intended for guidance only. Invensys will accept no responsibility for any losses arising from errors in this document.

FOXBORO ECKARDT GmbH
 Pragstr. 82
 D-70376 Stuttgart
 Germany
 Tel. +49 (0)711 502-0
 Fax +49 (0)711 502-597
<http://www.foxboro-eckardt.com>



DOKT 558 616 025

invensys