

**I/A Series® Intelligent
Electronic Multivariable Transmitters**

**IMV31-T Density Compensated Level Transmitters
with HART or 4 to 20 mA Output Signals**

**Installation, Calibration, Configuration, and Maintenance
Style A**

Contents

Figures.....	v
Tables.....	vi
1. Introduction	1
General Description	1
Tank Level Measurement	1
Reference Documents	2
Transmitter Identification	3
Standard Specifications	4
Product Safety Specifications	10
ATEX and IECEx Warnings	12
ATEX Compliance Documents	12
IECEx Compliance Documents	12
2. Installation	13
Transmitter Mounting	13
Process-Mounted Transmitter	13
Pipe- or Surface-Mounted Transmitter	14
Transmitter Piping	14
Positioning Housing	15
Positioning Optional Display	16
Setting the Write Protect Jumper	16
Cover Locks	16
Transmitter Wiring	17
Accessing Transmitter Field Terminals	17
Supply Voltage	18
Electrical Ground Connections	18
Wiring the Transmitter	18
Wiring the Transmitter to a Loop	18
Multidrop Communication	20
Connecting the Transmitter to an I/A Series System	21
Connecting the RTD	23
3. Calibration and Configuration	25
Calibration	25
Configurable Parameters	27
Calibration and Configuration Using a PCMV Field Device Configurator	29
Calibration and Configuration Using a PC-Based Configurator	29

Calibration and Configuration Using a HART Communicator	30
Online Menu	30
Explanation of Parameters	32
Calibration and Configuration Using the Optional Local Display	35
Entering Numerical Values	36
Calibration	37
Configuration	43
Viewing the Database	53
Testing the Display	53
Error Messages	53
4. Maintenance.....	57
Fault Analysis	57
Parts Replacement	57
Replacing the Electronics Module	57
Removing and Reinstalling a Housing Assembly	59
Replacing the Sensor Assembly	59
Replacing the Terminal Block Assembly	61
Adding the Optional Display	61
Index	63

Figures

1	Transmitter Identification	3
2	Minimum Allowable Absolute Pressure vs. Sensor Temperature with Fluorinert Fill Fluid	7
3	Process-Mounted Transmitter	13
4	Mounting Transmitter to a Pipe or Surface	14
5	Transmitter Piping Situations	15
6	Housing Screw or Clip Location	16
7	Accessing Field Terminals	17
8	Identification of Field Terminals	17
9	Supply Voltage and Loop Load	19
10	Loop Wiring Transmitters	20
11	Typical Multidrop Network	21
12	Typical Transmitter Wiring to an I/A Series System	22
13	RTD Wiring	23
14	Setup for Differential Pressure Calibration	26
15	Setup for Absolute Pressure Calibration	26
16	4 to 20 mA Output Calibration Setup	27
17	HART Communicator Online Menu (1 of 2)	30
18	HART Communicator Online Menu (2 of 2)	31
19	Local Display Module	35
20	Top Level Structure Diagram	36
21	Calibration Structure Diagram (1 of 3)	39
22	Calibration Structure Diagram (2 of 3)	40
23	Configuration Structure Diagram (1 of 5)	46
24	Replacing the Electronics Module Assembly and Display	58
25	Replacing the Sensor Assembly	60

Tables

1	Reference Documents	2
2	Minimum Loop Load and Supply Voltage Requirements	8
3	Electrical Safety Specifications	11
4	Minimum Loop Load and Supply Voltage Requirements	18
5	Configurable Parameters	28
6	Calibration Menu	37
7	Configuration Menu	44
8	Calibration Error Messages	53
9	Configuration Error Messages	55
10	Operation Error Messages	56

1. Introduction

General Description

The IMV31-T Electronic Multivariable Level Transmitter measures absolute and differential pressure, sensor and electronics temperature, and process temperature (from an RTD). When used for level measurement, it calculates level compensated for density changes that occur due to pressure and temperature changes and provides transmission of all the measured and calculated values.

The signals are transmitted to remote receivers over the same two wires that supply power to the transmitter electronics. These wires also carry two-way data signals between the transmitter and remote communication devices.

The transmitter allows direct analog connection to common receivers while still providing intelligent transmitter digital communications using a HART Communicator or PC-Based Configurator.

Tank Level Measurement

When using pressure or DP transmitters to measure tank liquid level, determining the liquid density is important to accurately calculate the level for a given liquid head pressure.

With closed tanks that may have a pressure above the liquid that is different from atmospheric pressure, a dry leg, wet leg, or diaphragm seal system can be used to port the top-of-tank pressure to the opposite side of a transmitter that is connected to the tank to measure level.

The density of the vapor above the liquid and the densities of vapor or liquid in the external piping connecting the transmitter to the tank also influences the calculation of level from the measured differential pressure.

The IMV31 Transmitter compensates for these density variations in order to calculate, display, and transmit an accurate liquid level measurement.

Liquid and vapor density calculations are based on the knowledge of the fluid properties, along with an on-line measurement of pressure and temperature.

Reference Documents

This document (MI 020-383) contains instructions for transmitter installation, configuration, calibration, and maintenance details. For further information relating to the use of this transmitter, refer to Table 1.

Table 1. Reference Documents

Document	Description
DP 020-432	Dimensional Print – IMV25, IMV30, and IMV31 Multivariable Transmitters
MI 020-427	Instruction – Intrinsic Safety Connection Diagrams and Nonincendive Circuits
MI 020-497	Instruction – PCMV Intelligent Field Device Configurator for use with IMV31 Density Compensated level Transmitters
MI 020-501	Instruction – PC50 Intelligent Device Tool (Installation and Parts List)
MI 020-505	Instruction – PC50 Intelligent Device Tool (Operation Using HART Protocol)
PL 009-020	Parts List – IMV31 Multivariable Transmitter
TI 37-75b	Technical Information – Transmitter Material Selection Guide

Transmitter Identification

See Figure 1 for transmitter data plate contents. For a complete explanation of the Model Number code, see PL 009-020. The firmware version is identified under **FMW REV** when **VIEW DB** (View Database) is selected in the top level structure (see Figure 20 on page 36).

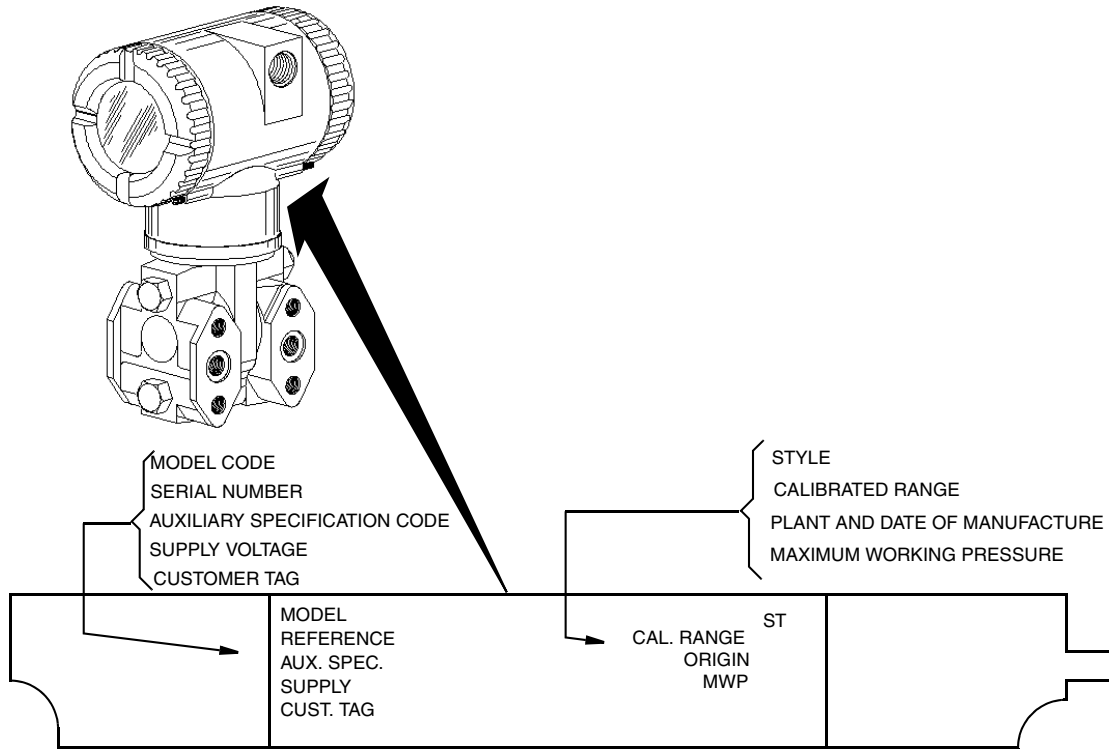

Figure 1. Transmitter Identification

Standard Specifications

Span and Range Limits for Differential Pressure Measurement

Span Limit Code	Span Limits ΔP	Range Limits $\Delta P^{(a)}$
A	0.75 and 7.5 kPa 3.0 and 30 inH ₂ O -76 and 760 mmH ₂ O	-7.5 and +7.5 kPa -30 and +30 inH ₂ O -760 and +760 mmH ₂ O
B	0.5 and 50 kPa 2 and 200 inH ₂ O 0.051 and 5.1 mH ₂ O	-50 and +50 kPa -200 and +200 inH ₂ O -5.1 and +5.1 mH ₂ O
C	2.5 and 210 kPa 10 and 840 inH ₂ O 0.25 and 21 mH ₂ O	-210 and +210 kPa -840 and +840 inH ₂ O -21 and +21 mH ₂ O

(a) Negative values of differential pressure indicate a higher pressure on the **low side** of the sensor. Positive values indicate a higher pressure on the **high side** of the sensor.

Span and Range Limits for Absolute Pressure Measurement

Span Limit Code	Span Limits ΔP	Range Limits ΔP
D	0.02 and 2.1 MPa (3 and 300 psia)	0 and 2.1 MPa (0 and 300 psia)
G	0.07 and 3.5 MPa (1 and 500 psia)	0 and 3.5 MPa (0 and 500 psia)
E	0.21 and 10 MPa ^(a) (30 and 1500 psia)	0 and 10 MPa (0 and 1500 psia)
H	0.42 and 20.7 MPa ^(a) (60 and 3000 psia)	0 and 20.7 MPa (0 and 3000 psia)

(a) For non-boiler applications, pressure must not exceed 6.9 MPaa (1000 psia).

Maximum Static, Working, and Overrange Pressure

Span Code ^(a)	Sensor URL		Maximum Static and Maximum Working Pressure (MWP)		Maximum Overrange	
	Differential Pressure	Absolute Pressure	MPa	psi	MPa	psi
A G	30 inH ₂ O	500 psia	3.5	500	5	750
B D	200 inH ₂ O	300 psia	2.1	300	3.1	450
B E	200 inH ₂ O	1500 psia ^(b)	10 ^(b)	1500 ^(b)	15 ^(c)	2250 ^(c)
B H	200 inH ₂ O	3000 psia ^(b)	20.7 ^(b)	3000 ^(b)	31.0 ^(c)	4500 ^(c)
C D	840 inH ₂ O	300 psia	2.1	300	3.1	450
C E	840 inH ₂ O	1500 psia ^(b)	10 ^(b)	1500 ^(b)	15 ^(c)	2250 ^(c)
C H	840 inH ₂ O	3000 psia ^(b)	20.7 ^(b)	3000 ^(b)	31.0 ^(c)	4500 ^(c)

(a) Available combinations of DP and AP sensors.

(b) For non-boiler applications, pressure must not exceed 6.9 MPaa (1000 psia).

(c) For non-boiler applications, overrange pressure must not exceed 10.3 MPaa (1500 psia).

— NOTE —

Static pressure zero shift for all calibrated spans can be minimized by readjusting the zero output at nominal operating static pressure.

— CAUTION —

Exceeding the maximum overrange pressure can cause damage to the transmitter degrading its performance.

Process Temperature Measurement

Measurement Element: 2-, 3-, or 4-wire, 100 ohm platinum RTD

DIN 43760; IEC 751, mean temperature coefficient (alpha) of 0.00385 ohms/ohm/°C

Range Limits: -200 and +850°C (-328 and +1562°F)

Elevated Zero and Suppressed Zero

For applications requiring an elevated or suppressed zero, the maximum span and the upper and lower range limits of the transmitter can not be exceeded.

Output Signal

The output is remotely configurable from a PC-Based Configurator or the HART Communicator. It is also locally configurable with the pushbuttons on the optional display.

Zero and Span Adjustments

The zero and span are remotely adjustable from the PC-Based Configurator or the HART Communicator. They are also adjustable at the transmitter using the optional display.

Field Wiring Reversal

Accidental reversal of field wiring does not damage the transmitter, provided the current is limited to 1 A or less by active current limiting or loop resistance. Sustained current of 1 A does not damage the electronics module or sensor but could damage the terminal block assembly and external instruments in the loop.

Mounting Position

The transmitter can be mounted in any orientation. Position effect zero shift for all calibrated spans can be eliminated by readjusting zero output after installation.

Adjustable Damping (DP and AP)

The transmitter response time is normally 1.0 second or the electronically adjustable setting of 0.00 (none), 0.25, 0.50, 1, 2, 4, 8, 16, or 32 seconds, whichever is greater, for a 90% recovery from an 80% input step as defined in ANSI/ISA S51.1.

Operative Limits

Influence	Normal Operating Conditions	Operative Limits
Sensor Body Temperature		
Silicone Fill Fluid	-29 and +82°C (-20 and +180°F)	-46 and +121°C (-50 and +250°F)
Fluorinert Fill Fluid	-29 and +82°C (-20 and +180°F)	-29 and +121°C (-20 and +250°F)
Electronics Temperature	-29 and +82°C (-20 and +180°F)	-40 and +85°C (-40 and +185°F)
With LCD Display	-20 and +82°C (-4 and +180°F)*	-29 and +85°C (-20 and +185°F)*
Relative Humidity	0 and 100%	0 and 100%
Supply Voltage	11.5 and 42 V dc	11.5 and 42 V dc
Output Load**	0 and 1450 ohms**	0 and 1450 ohms**
Mounting Position	Upright or horizontal	No Limit

*Display updates is slowed and readability decreased at temperatures below -20°C (-4°F).

**250 Ω minimum load is required for communication with a HART Communicator or PC-Based Configurator. Refer to Figure 9 on page 19.

Sensor Fill Fluid

Silicone Oil (DC 200) or Fluorinert (FC-43)

Minimum Allowable Absolute Pressure vs. Sensor Temperature

With Silicone Fill Fluid: At full vacuum: Up to 121°C (250°F)
 With Fluorinert Fill Fluid: Refer to Figure 2.

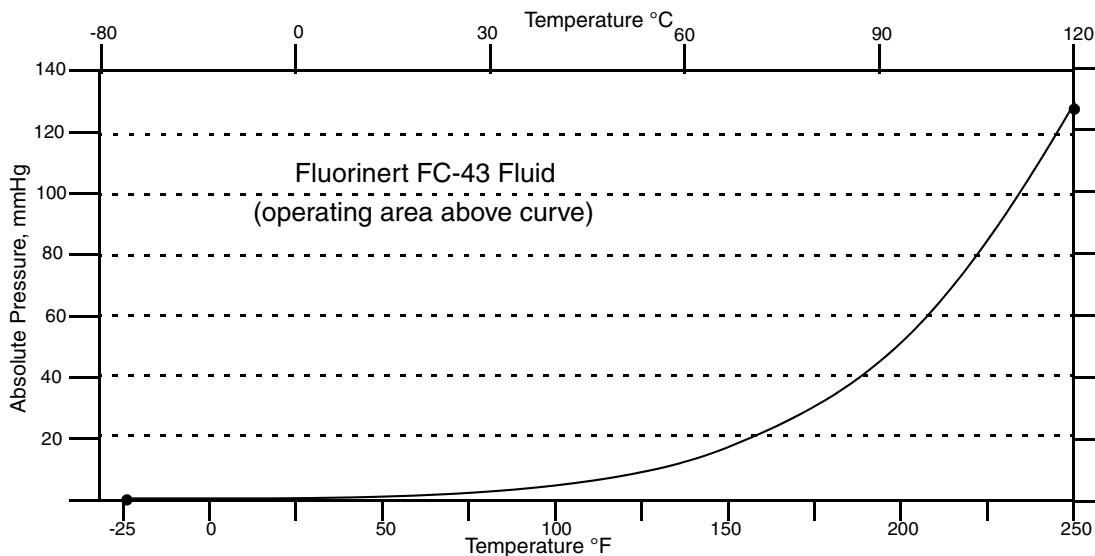

Figure 2. Minimum Allowable Absolute Pressure vs. Sensor Temperature with Fluorinert Fill Fluid

Electrical Connections

Field wires enter through 1/2 NPT, PG 13.5 or M20 threaded entrances on either side of the electronics housing. Leads terminate under screw terminals and washers on the terminal block in the field terminal compartment. Unused conduit connection must be plugged with metal plug provided to maintain RFI/EMI, environmental, and explosionproof ratings.

Process Connections

The transmitters are connected to the process via a 1/4 NPT thread or any one of a number of optional process connectors.

Supply Voltage

Power supply must be capable of providing 22 mA when the transmitter is configured for 4 to 20 mA output. Ripple of up to 2 V pp (50/60/100/120 Hz) is tolerable, but instantaneous voltage must remain within specified range.

The supply voltage and loop load must be within specified limits. This is explained in detail in “Wiring the Transmitter to a Loop” on page 18. A summary of the minimum requirements are listed in Table 2

Table 2. Minimum Loop Load and Supply Voltage Requirements

	HART Communication	No HART Communication
Minimum Resistance	250 Ω	0
Minimum Supply Voltage	17 V	11.5 V

Electrical Ground Connections

The transmitter is equipped with an internal ground connection within the field wiring compartment and an external ground connection at the base of the electronics housing. To minimize galvanic corrosion, place the wire lead or terminal between the captive washer and loose washer on the external ground screw. If shielded cable is used, earth (ground) the shield at the field enclosure **only**. Do **not** ground the shield at the transmitter.

Test Points

The two lower banana plug receptacles (designated **CAL**) can be used to check transmitter output when configured for 4 to 20 mA. Measurements should be 100-500 mV dc for 0-100% transmitter output. Refer to Figure 8.

Approximate Mass

Without Process Connectors	3.5 kg (7.8 lb)
With Process Connectors	4.2 kg (9.2 lb)
With Optional 316 ss Housing	Add 1.1 kg (2.4 lb)

Process Wetted Materials

Sensor: 316L ss or Hastelloy C

Covers and Process Connections: 316 ss or Hastelloy C

Remote Communications

The transmitter communicates bidirectionally over the 2-wire field wiring to a PC-based Configurator, a HART Communicator, and/or to the I/A Series system.

The information that can be continuously displayed is:

- ◆ Differential Pressure
- ◆ Pressure
- ◆ Process Temperature (from external RTD)
- ◆ Sensor Temperature
- ◆ Electronics Temperature
- ◆ Level
- ◆ Density of liquid in tank at actual pressure and temperature.

The information that can be remotely displayed and reconfigured, using the PC-based Configurator or HART Communicator includes:

- ◆ Output in mA, Percent, or Engineering Units (EGU)
- ◆ Zero and Span, including reranging
- ◆ Zero Elevation or Suppression
- ◆ Linear Output
- ◆ Pressure or Plant EGU
- ◆ RTD Failure Strategy
- ◆ Electronic Damping
- ◆ Poll Address (Multidrop mode)
- ◆ Fail-safe Direction
- ◆ Tag, Description, and Message
- ◆ Date of Last Calibration.

Communications Format

Communication is based upon the FSK (Frequency Shift Keying) technique. The frequencies are superimposed on the transmitter power/signal leads.

Output

The transmitter sends its measurement to the loop as a continuous 4 to 20 mA dc signal. The 4 to 20 mA signal can be assigned to any one of the measurements (differential pressure, absolute pressure, process temperature, electronics temperature, sensor temperature, level, or density). It communicates digitally with a HART Communicator at distances up to 3050 m or 10000 ft (1525 m or 5000 ft with multidrop communication). Communication between the remote configurator and the transmitter does not disturb the 4 to 20 mA output signal.

Other specifications are:

Data Transmission Rate	1200 Baud
4 to 20 mA Update Rate	30 times/second minimum (4 times/second with multidrop communications)
Output when Underrange	3.8 mA
Output when Overrange	20.5 mA
Output for Fail Low	3.6 mA
Output for Fail High	21 mA
Output when Off-line	Last value or configurable from 4 to 20 mA

Product Safety Specifications

— DANGER —

To prevent possible explosions and to maintain flameproof, explosionproof, and dust-ignitionproof protection, observe applicable wiring practices. Plug unused conduit opening with the provided metal pipe plug. Both plug and conduit must engage a minimum of five full threads for 1/2 NPT connections; seven full threads for M20 and PG 13.5 connections.

— WARNING —

To maintain IEC IP66 and NEMA Type 4X protection, the unused conduit opening must be plugged with the metal plug provided. Use a suitable thread sealant on both conduit connections. In addition, the threaded housing covers must be installed. Turn covers to seat the O-ring into the housing and then continue to hand tighten until the cover contacts the housing metal-to-metal.

— NOTE —

1. These transmitters have been designed to meet the electrical safety description listed in Table 3. For detailed information or status of testing laboratory approvals/certifications, contact Invensys.
 2. Wiring restrictions required to maintain electrical certification of the transmitter are provided in the “Transmitter Wiring” section of this document on page 17 and in MI 020-427.
-

Table 3. Electrical Safety Specifications

Testing Laboratory, Types of Protection, and Area Classification	Application Conditions	Electrical Safety Design Code
ATEX flameproof; II 2 GD EEx d IIC, Zone 1.	KEMA 00ATEX2019X Temperature Class T6, T85°C Ta = -40 to +80°C	D
ATEX intrinsically safe; II 1 GD, EEx ia IIC, Zone 0 or II 1/2 GD EEx ib IIC, Zone 0 and 1.	KEMA 00ATEX1009X Temperature Class T4 at 80°C, T5 at 40°C, and T6 at 40°C maximum ambient.	E
ATEX protection n; II 3 GD, EEx nL IIC, Zone 2.	KEMA 00ATEX1060X Temperature Class T4 at 80°C, T5 at 70°C, and T6 at 40°C maximum ambient.	N
ATEX multiple certifications, ia & ib, d, and n. Refer to Codes D, E and N for details.	Applies to Codes D, E, and N. ^(a)	M
CSA intrinsically safe for Class I, Division 1, Groups A, B, C, and D; Class II, Division 1, Groups E, F, and G; Class III, Division 1. Also, Zone certified intrinsically safe Ex ia IIC and energy limited Ex nA II.	Connect per MI 020-427. Temperature Class T4A at 40°C (104°F) and T3C at 85°C (185°F) maximum ambient. Temperature Class T4 at 40°C (104°F), and T3 at 85°C (185°F) max. ambient.	C
CSA explosionproof for Class I, Division 1, Groups B, C, and D; and dust-ignitionproof apparatus for Class II, Division 1, Groups E, F, and G; and Class III, Division 1.	Maximum Ambient Temperature 85°C (185°F).	
CSA for Class I, Division 2, Groups A, B, C, and D; Class II, Division 2, Groups F and G; and Class III, Division 2.	Temperature Class T4A at 40°C (104°F) and T3C at 85°C (185°F) maximum ambient	
CSA field device zone certified flameproof Ex d IIC. Also, all certifications of Code C above.	Maximum Ambient Temperature 85°C (185°F).	B

Table 3. Electrical Safety Specifications

Testing Laboratory, Types of Protection, and Area Classification	Application Conditions	Electrical Safety Design Code
FM intrinsically safe for Class I, Division 1, Groups A, B, C, and D; Class II, Division 1, Groups E, F, and G; and Class III, Division 1. Also, Zone certified intrinsically safe AEx ia IIC.	Connect per MI 020-427. Temperature Class T4A at 85°C (185°F) maximum ambient. Temperature Class T4 at 85°C (185°F) maximum ambient.	F
FM explosionproof for Class I, Division 1, Groups B, C, and D; and dust-ignitionproof apparatus for Class II, Division 1, Groups E, F, and G; and Class III, Division 1.	Temperature Class T6 at 80°C (176°F) and T5 at 85°C (185°F) maximum ambient.	
FM nonincendive apparatus for Class I, Division 2, Groups A, B, C, and D; Class II, Division 2, Groups F and G; and Class III, Division 2.	Temperature Class T4A at 85°C (185°F) maximum ambient.	
FM field device zone certified flameproof AEx d IIC. Also, all certifications of Code F above.	Temperature Class T6 at 80°C (176°F) and T5 at 85°C (185°F) maximum ambient.	G
IECEX flameproof: Ex d IIC	IECEX FMG 06.0007X, Ex d IIC T6 Ta=80°C, T5 Ta=85°C Ambient Temperature -20 to +85°C	V

(a) User must permanently mark (check off in rectangular block on data plate) one type of protection only (ia and ib or n). This mark cannot be changed once it is applied.

ATEX and IECEX Warnings

Do not open while circuits are alive.

ATEX Compliance Documents

EN 50014: 1997

EN 50018: 1994

EN 50020: 1994

EN 50284: 1999

EN 50021: 1999

IECEX Compliance Documents

IEC 60079-0 (Edition 4.0): 2004

IEC 60079-1 (Edition 5): 2003

2. Installation

The following material provides information and procedures for installing the transmitter. For dimensional information, refer to DP 020-432.

— **! CAUTION** —

To avoid damage to the transmitter sensor, do not use any impact devices, such as an impact wrench or stamping device, on the transmitter.

— **NOTE** —

Use a suitable thread sealant on all connections.

Transmitter Mounting

The transmitter can be supported by the process piping as shown in Figure 3 or mounted to a vertical or horizontal pipe or surface using the optional mounting bracket shown in Figure 4.

— **NOTE** —

1. If the transmitter is not installed in the vertical position as shown in Figure 3 or Figure 4, readjust zero output to eliminate the position zero effect.
 2. The transmitter should be mounted so that any moisture condensing or draining into the field wiring compartment can exit through one of the two threaded conduit connections.
-

Process-Mounted Transmitter

Figure 3 shows the transmitter mounted to and supported by the process piping.

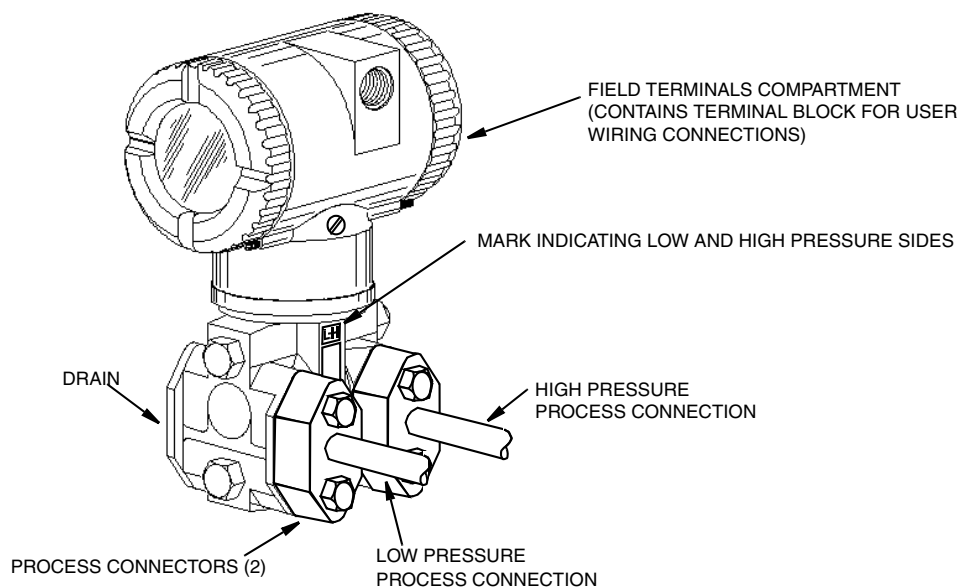

Figure 3. Process-Mounted Transmitter

Pipe- or Surface-Mounted Transmitter

To mount the transmitter to a pipe or surface, use the Optional Mounting Set (Model Code Option -M).

Referring to Figure 4, secure the mounting bracket to the transmitter using the two lockwashers and screws provided. Mount the transmitter with mounting bracket to a vertical or horizontal, DN 50 or 2-in pipe. To mount to a horizontal pipe, turn the U-bolt 90° from the position shown in Figure 4. The mounting bracket can also be used for wall mounting by securing the bracket to a wall using the U-bolt mounting holes.

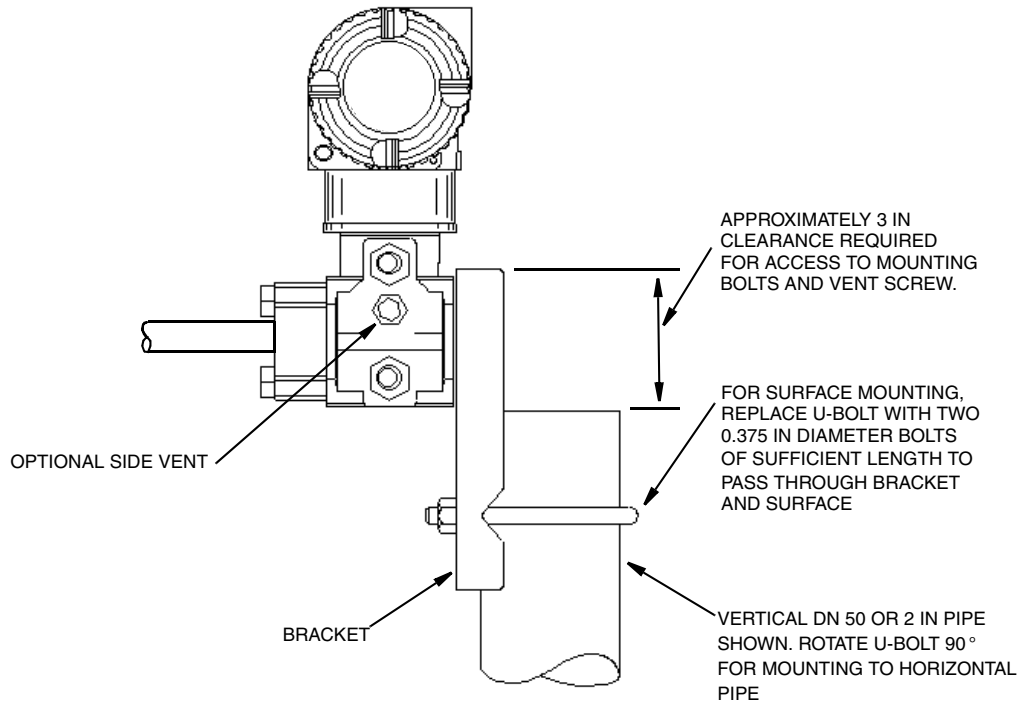

Figure 4. Mounting Transmitter to a Pipe or Surface

Transmitter Piping

Mount transmitters below the level of the pressure connection at the tank. Note that the high and low pressure sides of the transmitter are identified by an L-H marking on the side of the sensor as shown in Figure 3.

Open Tank:

- Connect the high pressure side of the transmitter to the tank
- Connect the low pressure side of the transmitter to atmosphere

Closed Tank with a Dry Leg:

- Connect the high pressure side of the transmitter to the tank
- Connect the low pressure side of the transmitter to the dry leg

Closed Tank with a Wet Leg. Dual Seals, or Boiler Drum Application:

- Connect the high pressure side of the transmitter to the wet leg

Connect the low pressure side of the transmitter to the tank

— **NOTE** —

If you do not connect your transmitter in this way, it will not operate properly.

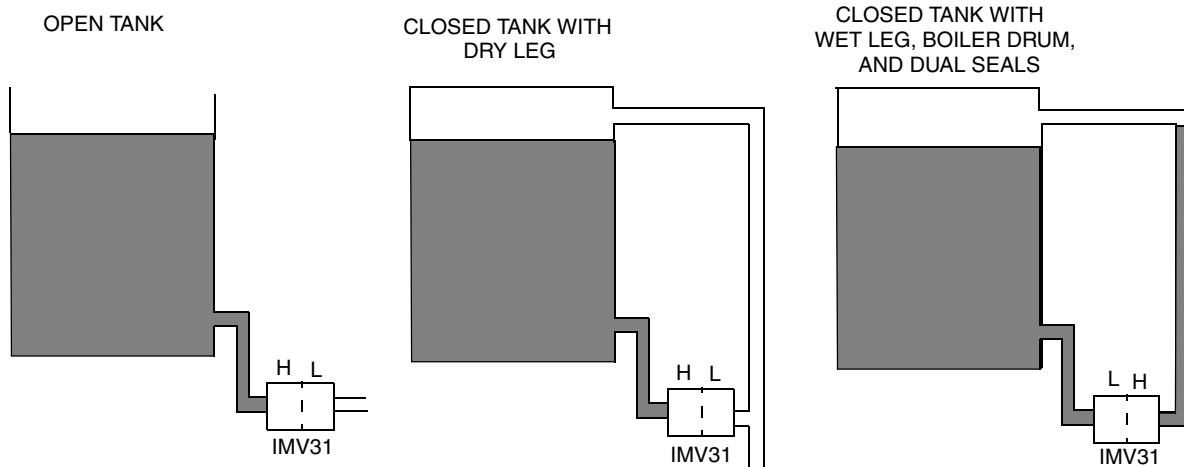

Figure 5. Transmitter Piping Situations

Tighten drain plugs and optional vent screws to 20 N·m (15 lb·ft). Tighten the four process connector bolts to a torque of 61 N·m (45 lb·ft).

Positioning Housing

The transmitter housing (topworks) can be rotated up to one full turn in the counterclockwise direction when viewed from above for optimum access to adjustments, display, or conduit connections. Housings have either an anti-rotation screw or a retention clip that prevent the housing from being rotated beyond a safe depth of housing/sensor thread engagement.

— **! WARNING** —

If the electronics housing is removed for maintenance, it must be hand tightened to the bottom of the threads, but not over-tightened upon reassembly. See “Removing and Reinstalling a Housing Assembly” on page 59.

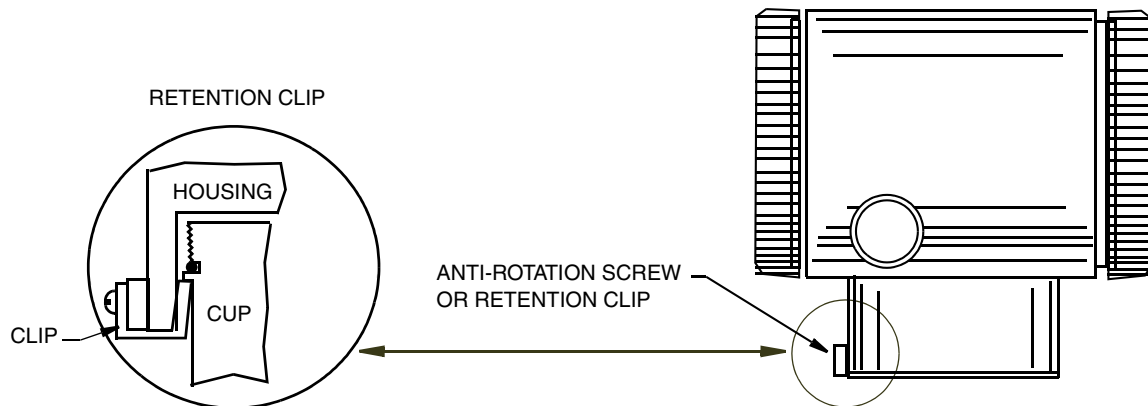

Figure 6. Housing Screw or Clip Location

Positioning Optional Display

The optional display can be rotated within the housing to any of four positions at 90° increments. To do this, grasp the two tabs on the display and rotate it about 10° in a counterclockwise direction. Pull out the display. Ensure that the O-ring is fully seated in its groove in the display housing. Turn the display to the desired position, reinsert it in the electronics module, aligning the tabs on the sides of the assembly, and twist it in the clockwise direction.

! CAUTION

Do not turn the display more than 180° in any direction. Doing so could damage its connecting cable.

Setting the Write Protect Jumper

Your transmitter has write protection capability which meets the security requirements of ISA-S84.01-1986 for use in safety shutdown systems. This means that the local display and remote communications can be prevented from writing to the electronics. Write protection is set by moving a jumper that is located in the electronics compartment behind the optional display (see Figure 24 on page 58). To activate write protection, remove the display as described in the previous section, then remove the jumper or move it to the lower position as shown on the exposed label. Replace the display.

Cover Locks

Electronic housing cover locks, shown in Figure 7, are provided as standard with certain agency certifications and as part of the Custody Transfer Lock and Seal option. To lock the covers, unscrew the locking pin until approximately 6 mm (0.25 in) shows, lining up the hole in the pin with the hole in the housing. Insert the seal wire through the two holes, slide the seal onto the wire ends and crimp the seal.

Transmitter Wiring

The installation and wiring of your transmitter must conform to local code requirements.

— NOTE —

The transmitter includes transient surge protection as standard. However, Invensys recommends the use of additional transient/surge protection in installations prone to unusually high levels of electrical transients and surges.

Accessing Transmitter Field Terminals

For access to the field terminals, thread the cover lock (if present) into the housing to clear the threaded cover and remove the cover from the field terminals compartment as shown in Figure 7. Note that the embossed letters **FIELD TERMINALS** identify the proper compartment. Identification of terminals is shown in Figure 8.

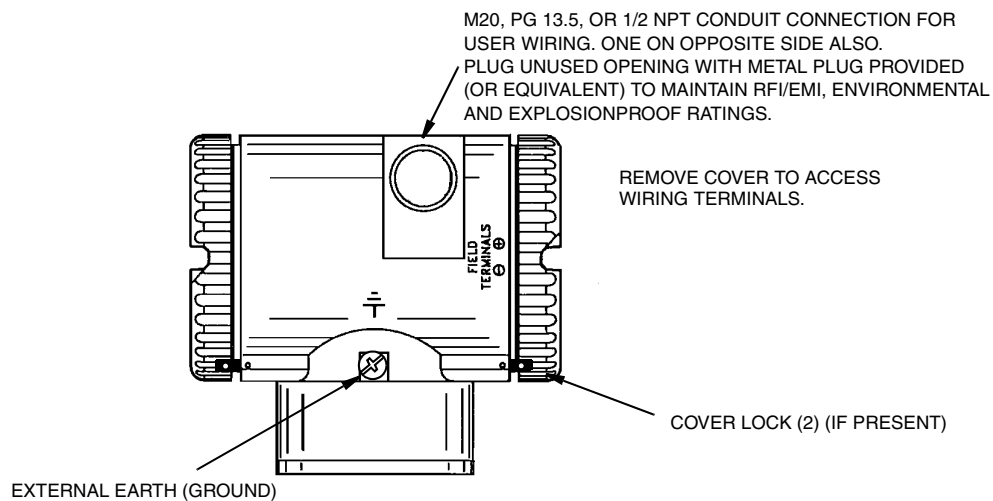

Figure 7. Accessing Field Terminals

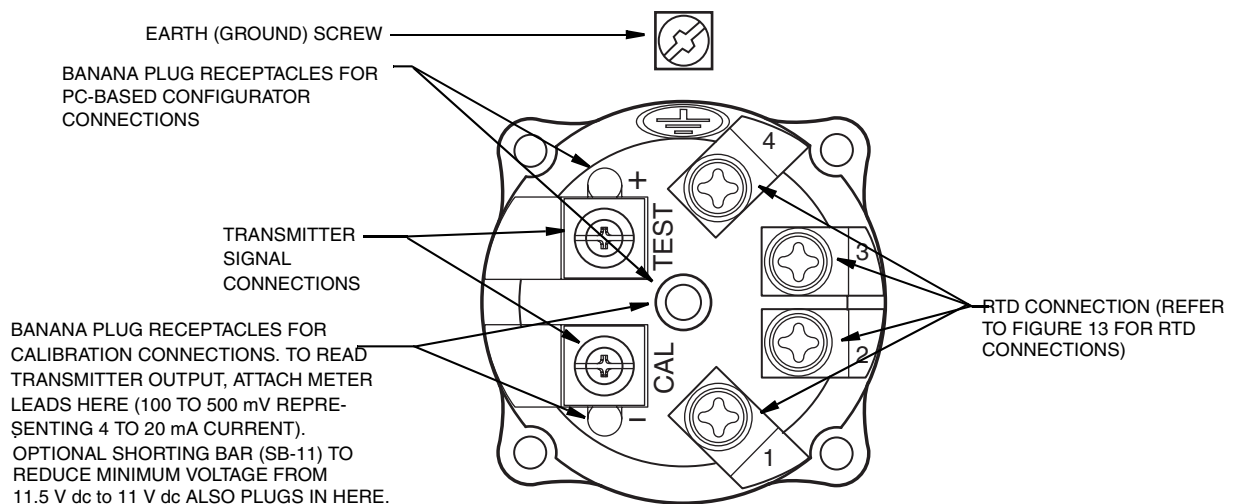

Figure 8. Identification of Field Terminals

Supply Voltage

Power supply must be capable of providing 22 mA when the transmitter is configured for 4 to 20 mA output. Ripple of up to 2 V pp (50/60/100/120 Hz) is tolerable, but instantaneous voltage must remain within specified range.

The supply voltage and loop load must be within specified limits. This is explained in detail in “Wiring the Transmitter to a Loop” on page 18. A summary of the minimum requirements are listed in Table 4.

Table 4. Minimum Loop Load and Supply Voltage Requirements

	Remote Configurator Communication	No Remote Configurator Communication
Minimum Resistance	250 Ω	0
Minimum Supply Voltage	16 V	11.5 V

Electrical Ground Connections

The transmitter is equipped with an internal ground connection within the field wiring compartment and an external ground connection at the base of the electronics housing. To minimize galvanic corrosion, place the wire lead or terminal between the captive washer and loose washer on the external ground screw. If shielded cable is used, earth (ground) the shield at the field enclosure **only**. Do **not** ground the shield at the transmitter.

Wiring the Transmitter

The transmitter can send its measurement to the loop as a continuous 4 to 20 mA dc signal. It also can communicate digitally with a HART Communicator or PC-Based Configurator at distances up to 3050 m or 10000 ft (1525 m or 5000 ft with multidrop communication). Communication between the remote configurator and the transmitter does not disturb the 4 to 20 mA output signal.

The transmitter can also send its measurement to the I/A Series system as a digital signal via an FBM214/215.

Wiring the Transmitter to a Loop

When wiring a transmitter to a loop, the supply voltage and loop load must be within specified limits. The supply output load vs. voltage relationship is:

$$R_{MAX} = 47.5 (V - 11.5) \text{ and is shown in Figure 9.}$$

— NOTE —

The relationship when the optional shorting bar is used is:

$$R_{MAX} = 46.8 (V - 11).$$

Any combination of supply voltage and loop load resistance in the shaded area can be used. To determine the loop load resistance (transmitter output load), add the series resistance of each component in the loop, excluding the transmitter. The power supply must be capable of supplying 22 mA of loop current.

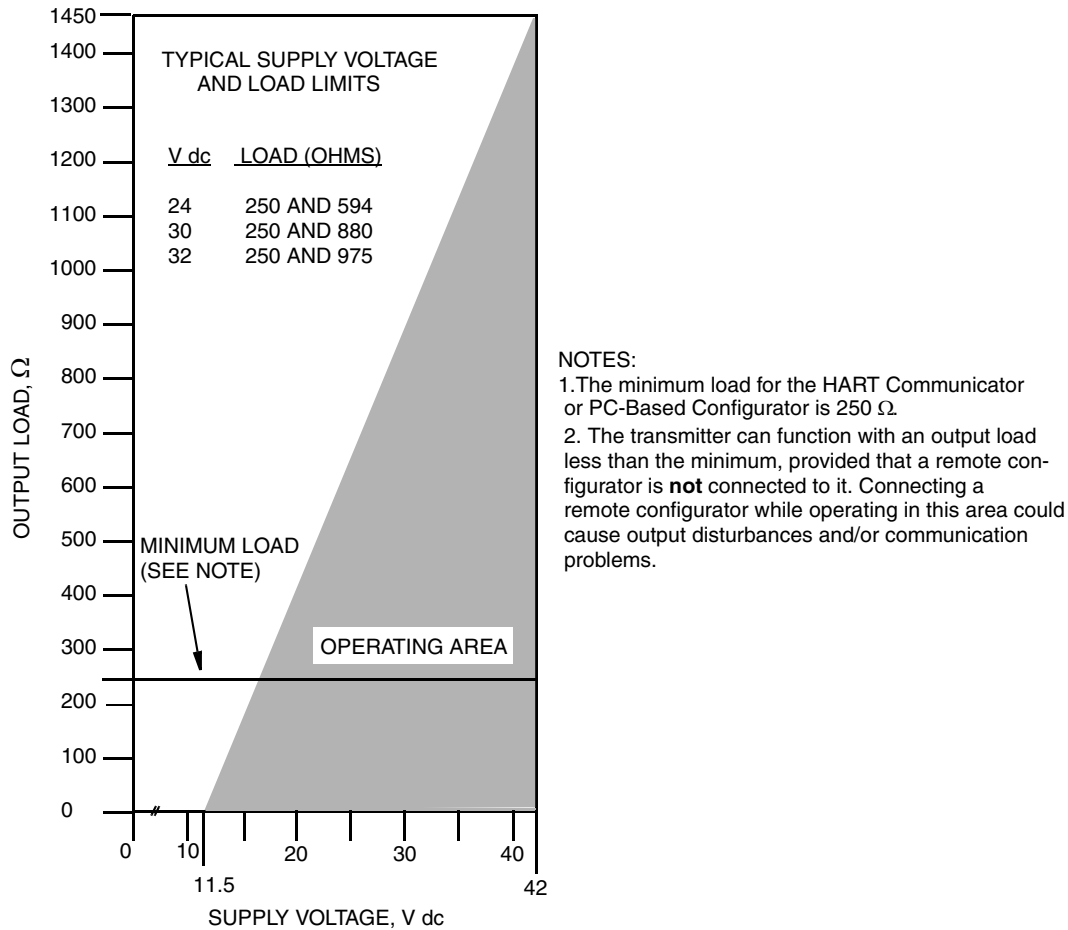

Figure 9. Supply Voltage and Loop Load

Examples:

1. For a loop load resistance of 880 Ω, the supply voltage can be any value from 30 to 42 V dc.
2. For a supply voltage of 24 V dc, the loop load resistance can be any value from 200 to 594 Ω (zero to 594 Ω without a remote configurator connected to the transmitter).

To wire one or more transmitters to a power supply, proceed with the following steps.

1. Remove the cover from the transmitter field terminals compartment.
2. Run signal wires (0.50 mm² or 20 AWG, typical) through one of the transmitter conduit connections as shown in Figure 7. Use twisted pair to protect the 4 to 20 mA output and/or remote communications from electrical noise. Maximum recommended length for signal wires is 3050 m (10000 ft)

— NOTE

Do not run transmitter wires in the same conduit as mains (ac power) wires.

3. If shielded cable is used, earth (ground) the shield at the receiver **only**. Do not ground the shield at the transmitter.

4. Plug unused conduit connection with the 1/2 NPT, PG 13.5 or M20 metal plug provided (or equivalent). To maintain specified explosionproof and dust-ignitionproof protection, plug must engage a **minimum** of five full threads.
5. Connect an earth (ground) wire to the earth terminal in accordance with local practice.

— **! CAUTION** —

If the signal circuit must be earthed (grounded), it is preferable to do so at the negative terminal of the dc power supply. To avoid errors resulting from earth loops or the possibility of short-circuiting groups of instruments in a loop, there should be only one earth in a loop.

6. Connect the power supply and receiver loop wires to the “+” and “-” terminal connections shown in Figure 8.
7. Connect receivers (such as controllers, recorders, indicators) in series with power supply and transmitter as shown in Figure 10.
8. Install the cover onto the transmitter.
9. The HART Communicator or PC-Based Configurator can be connected in the loop between the transmitter and the power supply as shown in Figure 10. Note that a minimum of 250 Ω must separate the power supply from the remote configurator.

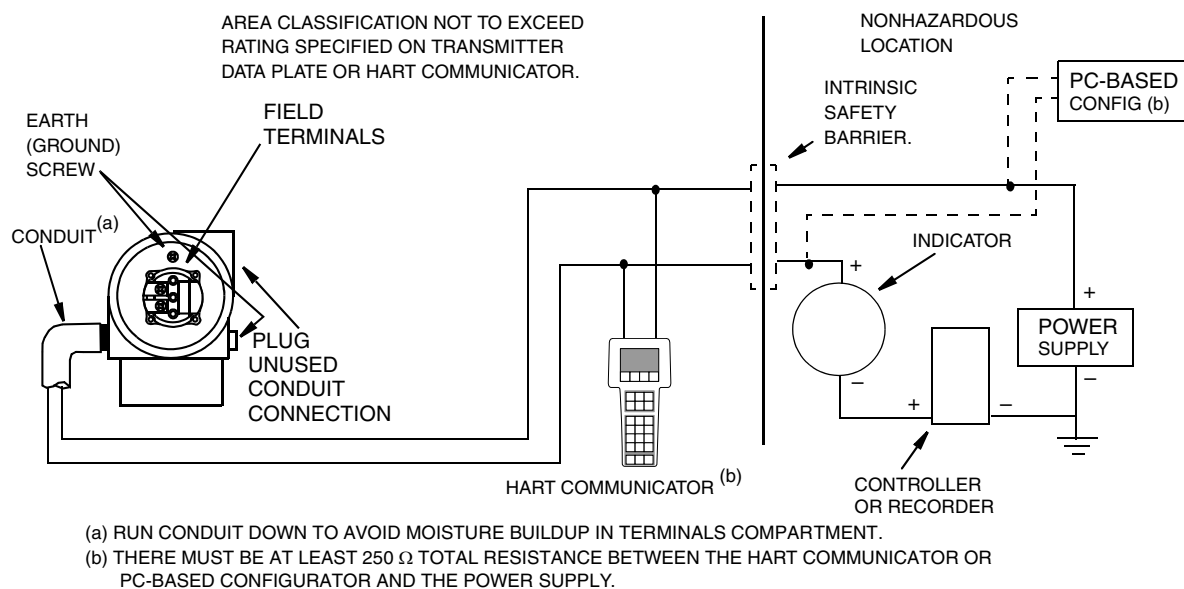

Figure 10. Loop Wiring Transmitters

Multidrop Communication

“Multidropping” refers to the connection of several transmitters to a single communications transmission line. Communications between the host computer and the transmitters takes place digitally with the analog output of the transmitter deactivated. With the HART communications protocol, up to 15 transmitters can be connected on a single twisted pair of wires or over leased telephone lines.

The application of a multidrop installation requires consideration of the update rate necessary from each transmitter, the combination of transmitter models, and the length of the transmission line. Multidrop installations are not recommended where intrinsic safety is a requirement. Communication with the transmitters can be accomplished with an appropriate HART compatible modem and a host implementing the HART protocol. Each transmitter is identified by a unique address (1-15) and responds to the commands defined in the HART protocol.

Figure 11 shows a typical multidrop network. Do **not** use this figure as an installation diagram. Contact the HART Communications Foundation, (512) 794-0369, with specific requirements for multidrop applications.

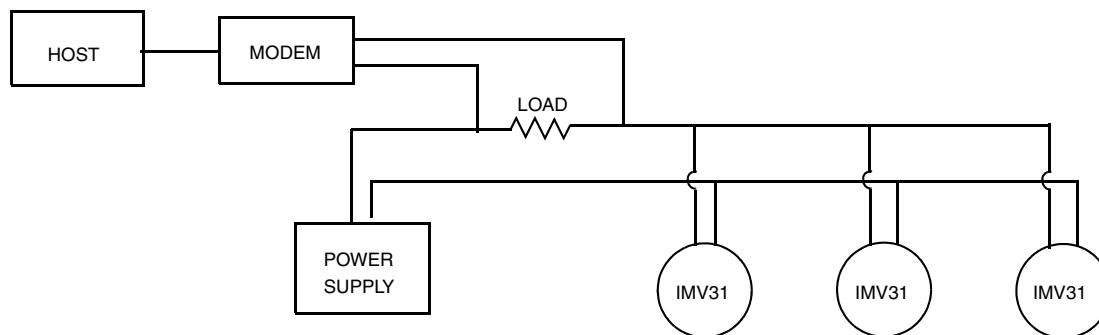

Figure 11. Typical Multidrop Network

The HART Communicator can operate, configure, and calibrate IMV31 Transmitters with HART communication protocol in the same way as it can in a standard point-to-point installation.

— NOTE —

IMV31 Transmitters with HART communication protocol are set to poll address 0 (**POLLADR 0**) at the factory, allowing them to operate in the standard point-to-point manner with a 4 to 20 mA output signal. To activate multidrop communication, the transmitter address must be changed to a number from 1 to 15. Each transmitter must be assigned a unique number on each multidrop network. This change deactivates the 4 to 20 mA analog output.

Connecting the Transmitter to an I/A Series System

The transmitter can also send its measurement to the I/A Series system as a digital signal via FBM214/215. The following procedure identifies wire terminations in the transmitter. For other system wiring details, refer to the installation instructions provided with the I/A Series system.

1. Remove the cover from the transmitter field terminal compartment.
2. Run signal wires (0.50 mm² or 20 AWG, typical) through one of the transmitter conduit connections as shown in Figure 12. Use twisted pair to protect the digital output and/or remote communications from electrical noise. Screened (shielded) cable may be required in some locations.

— NOTE —

Do **not** run transmitter wires in the same conduit as mains (ac power) wires.

3. If shielded cable is used, earth (ground) the shield at the field enclosure **only**. Do not ground the shield at the transmitter.
4. Plug unused conduit connection with the 1/2 NPT, PG 13.5, or M20 metal plug provided (or equivalent). To maintain specified explosionproof and dust-ignitionproof protection, plug must engage a **minimum** of five full threads.

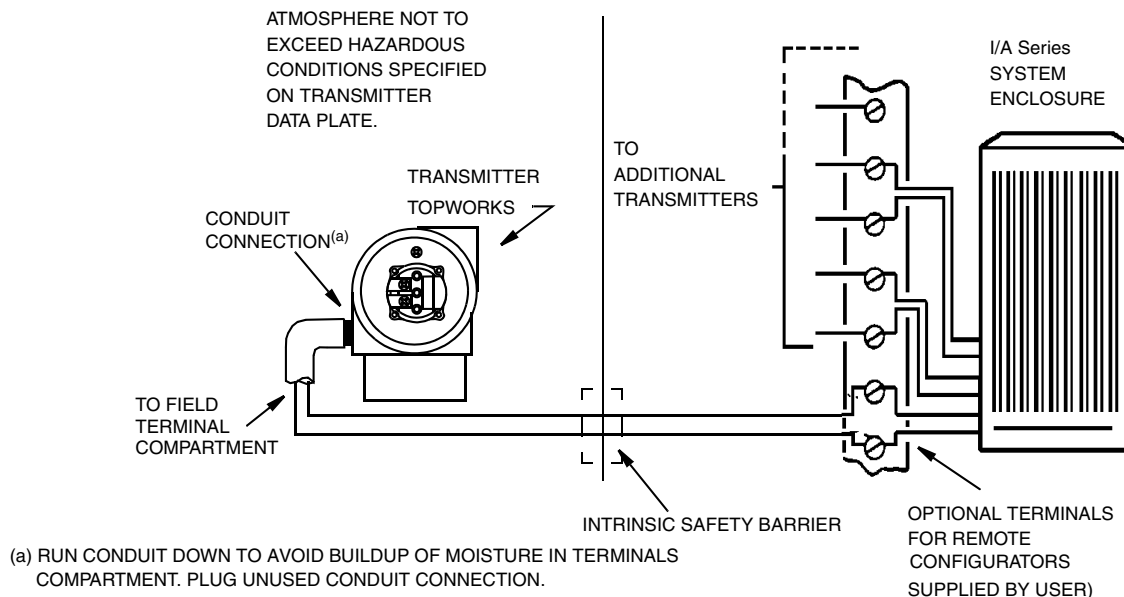

Figure 12. Typical Transmitter Wiring to an I/A Series System

5. Connect an earth (ground) wire to the earth terminal in accordance with local practice. Ground terminal is shown in Figure 8.

! CAUTION

To avoid errors resulting from earth loops or the possibility of short-circuiting groups of instruments in a loop, use only one earth in a loop.

6. Connect the signal wires to the transmitter “+” and “-” terminal connections shown in Figure 8.
7. The HART Communicator or PC-Based Configurator can be connected via banana plugs to the top two receptacles (designated **TEST**) on the terminal block in the field terminal compartment as shown in Figure 8 or any other convenient location in the loop (subject to hazardous location restrictions).
8. Reinstall the cover on the transmitter. Turn the cover to seat the O-Ring into the housing and continue to hand tighten until the cover contacts the housing metal-to-metal. If cover locks are present, refer to “Cover Locks” on page 16.

Connecting the RTD

— **! WARNING** —

For CE compliance, metallic conduit is required between the transmitter and the RTD. Invensys recommends the use of metallic conduit for all installations.

Connect your RTD to terminals 1, 2, 3 and 4. Locations are shown in Figure 8. Wire per Figure 13.

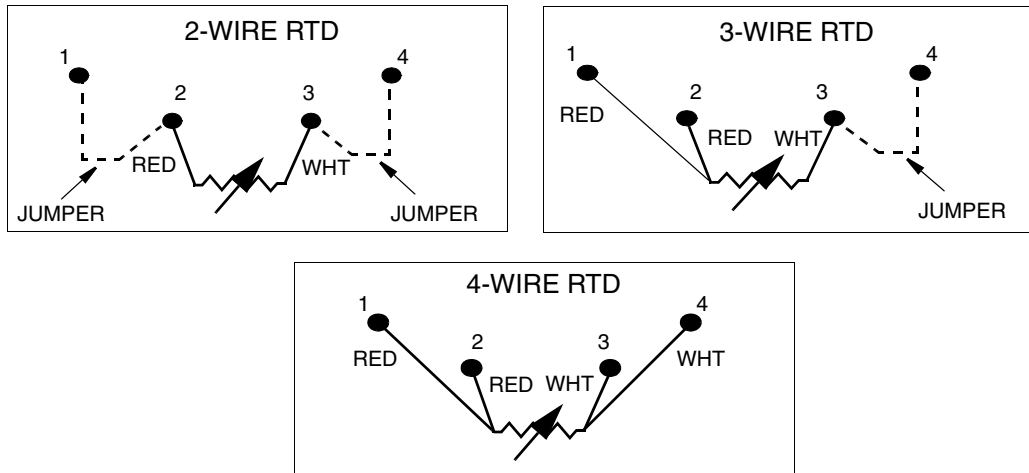

Figure 13. RTD Wiring

— **NOTE** —

Only a 4-wire RTD is compensated for by the transmitter and thus yields the most accurate measurement.

3. Calibration and Configuration

— **NOTE** —

This chapter depicts information on changes that can be made to the IMV31 using a HART Communicator, PC-Based Configurator, or the local display. It must be understood that these configuration methods cannot configure the IMV31 for a specific application, but can only modify some parameter values after the initial configuration. Either a PCMV Field Device Configurator must be used to define the tank and process properties or the factory configuration option (C2 option) must be selected and the Multivariable Wizard must be run prior to entering the order with the factory. Please see MI 020-497 for specifics related to configuring the IMV31 for a liquid level application and for a sample configuration tutorial.

Calibration

Although your IMV31 Transmitter usually does not require any calibration, you may calibrate each of its measurements. Some calibration procedures are meant to be done in the field at the tank and others on the bench. Use test equipment that is at least three times as accurate as the desired accuracy of the transmitter.

— **NOTE** —

It is not necessary to set up calibration equipment to rerange the transmitter to a different range. The transmitter can be accurately reranged by simply changing the Lower Range Value and the Upper Range Value, which are stored in the transmitter database.

Differential Pressure Calibration

Calibration at the lower and upper range value or user defined points are meant to be done on the bench. It is not practical to do these calibrations in the field. The setup for these calibration is shown in Figure 14.

— **NOTE** —

The ability to calibrate at user defined points (other than LRV and URV) is not provided at the local display.

Calibration at zero differential pressure can be done at the bench or in the field with an empty tank. In doing this calibration, you can achieve zero differential pressure by venting both sides of the transmitter to atmosphere or by using a 3-valve manifold and opening the bypass valve.

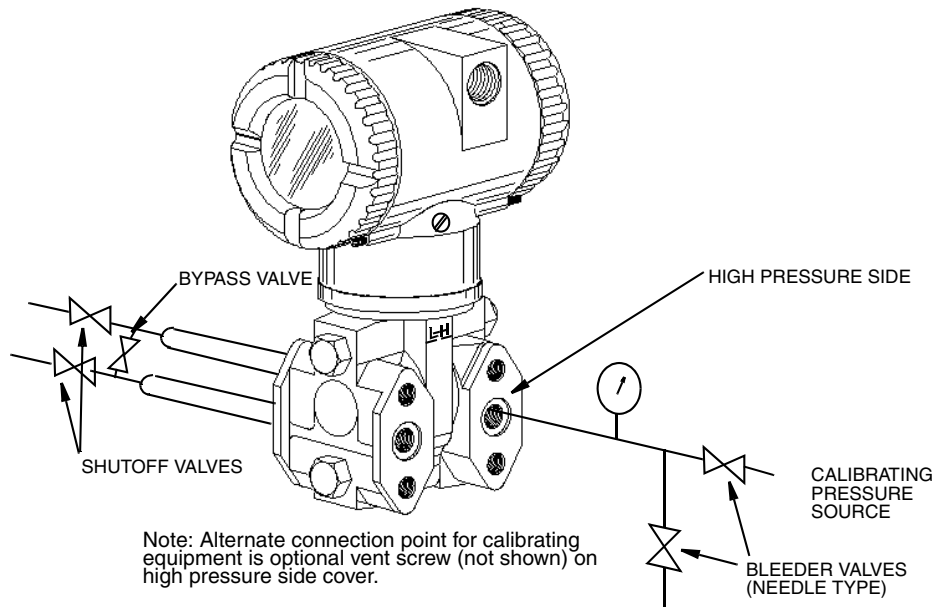

Figure 14. Setup for Differential Pressure Calibration

Pressure Calibration

Pressure calibration on the bench can be done at one or two user defined points. The setup for this calibration is shown in Figure 15.

— NOTE

Apply the calibrating pressure to both sides of the transmitter simultaneously.

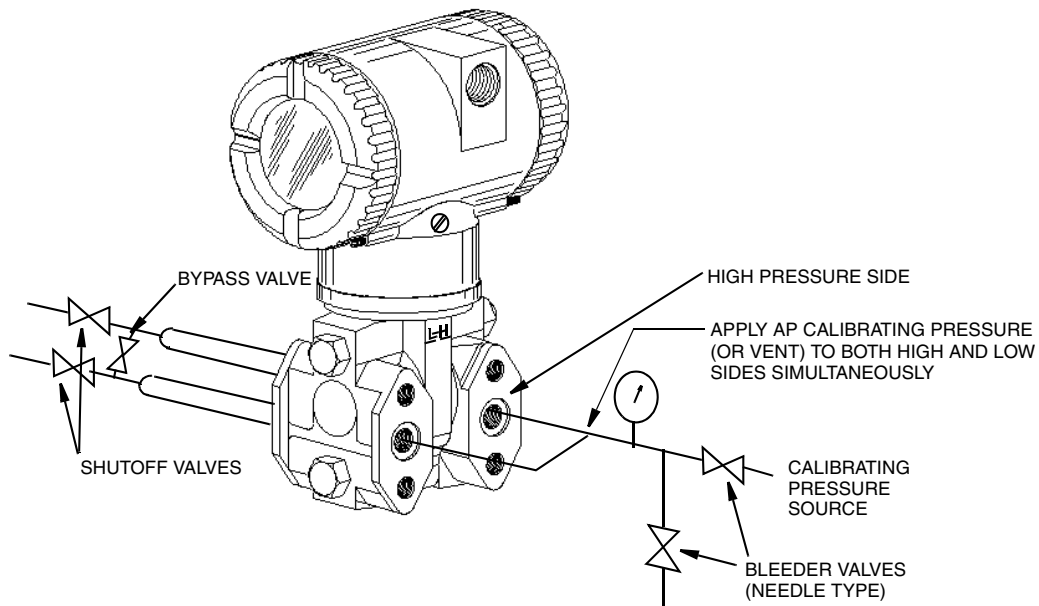

Figure 15. Setup for Absolute Pressure Calibration

— NOTE —

1. If calibrated at atmospheric pressure, both sides of the transmitter can be vented to atmosphere.
2. **1PntCAL** and **2PntCAL** (from the local display) or **Cal AP @ 1 User Pt** and **Cal AP @ 2 User Pts** (from a HART Communicator) can be done on a bench or in the field with an empty tank (the upper and lower wet legs must also be empty).
3. **Cal M2 at 1 User Pt** (from a HART Communicator or PC-Based Configurator) allows you to perform a 1-point calibration while the transmitter is installed on the tank. To do this, vent the top of a closed tank to atmosphere. The ability to perform this field calibration is not provided at the local display.

Sensor, Electronic, or RTD Temperature Calibration

Temperature calibrations are offset calibrations achieved by adjusting the temperature reading in the transmitter to an actual temperature. These calibrations are not recommended if the temperature is not one of the measured variables.

Level Calibration

Level calibration is a field calibration procedure. It can be done at one or two user-defined points. For the **Zero** calibration, enter the desired level output value at the current tank level (less than 1/3 of the full level span). For the **Span** calibration, enter the desired level output value at the current tank level (greater than 2/3 of the full level span).

Calibration of 4 to 20 mA Output Signal

If you are calibrating the 4 to 20 mA output signal, also connect the electronic equipment as shown in Figure 16.

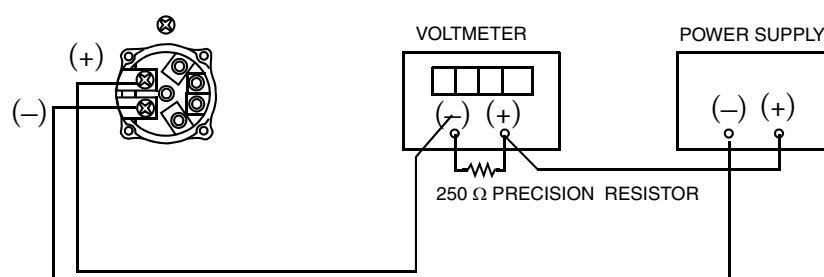

Resistor: 250 Ω , $\pm 0.01\%$, 1 W minimum (Part No. E0309GY)

Power Supply: Refer to Figure 9

Digital Voltmeter: readings from 1.000 to 5.000 V dc

Figure 16. 4 to 20 mA Output Calibration Setup

Configurable Parameters

Table 5 lists all of the configurable parameters and the factory default for the IMV31 Transmitter. The factory default values have been customized if the transmitter was ordered with optional

feature -C2. The table also shows which parameters are configurable with the integral vs. remote configurators.

Table 5. Configurable Parameters

Parameter	Capability	Factory Default	Configurable with		
			Integral Indicator	PC-Based Config.	HART Comm.
Poll Address	0 - 15	0	Yes	Yes	Yes
Descriptors					
Tag Number	8 characters max	Tag Number	No	Yes	Yes
Descriptor	16 characters max	Tag Name	No	Yes	Yes
Message	32 characters max	Instr Location	No	Yes	Yes
Dynamic Variable Assignment					
Primary Measurement/Calculation	D/P, A/P, Level, Density	Level	Yes	Yes	Yes
Secondary Measurement/Calculation	D/P, A/P, RTD, Level, Density, Sensor Temp, Electronics Temp	D/P	Yes	Yes	Yes
Tertiary Measurement/Calculation	D/P, A/P, RTD, Level, Density, Sensor Temp, Electronics Temp	A/P	Yes	Yes	Yes
Fourth Measurement/Calculation	D/P, A/P, RTD, Level, Density, Sensor Temp, Electronics Temp	RTD	Yes	Yes	Yes
mA					
Direction	Forward or Reverse	Forward	Yes	No	No
Failsafe	Fail mode output - High or Low	High	Yes	Yes	Yes
Offline	Offline output - last value or user set from 4 to 20 mA	User set at 4 mA	Yes	No	No
D/P					
Units	Pressure units	Units of Calibrated Range	Yes	Yes	Yes
D/P LRV	D/P LRV	Same as Calibrated Range	Yes	Yes	Yes
D/P URV	D/P URV	Same as Calibrated Range	Yes	Yes	Yes
Damping	0 to 32 seconds	None	Yes	Yes	Yes
A/P					
Mode	Display AP or GP	AP	Yes	Yes	Yes
Units	Pressure units	Units of Calibrated Range	Yes	Yes	Yes
A/P LRV	A/P LRV	Same as Calibrated Range	Yes	Yes	Yes
A/P URV	A/P URV	Same as Calibrated Range	Yes	Yes	Yes

Table 5. Configurable Parameters (Continued)

Parameter	Capability	Factory Default	Configurable with		
			Integral Indicator	PC-Based Config.	HART Comm.
ATM REF	Atmospheric Pressure	14.7 psi	Yes	Yes	Yes
Damping	0 to 32 seconds	None	Yes	Yes	Yes
RTD					
Mode	On or Off	On	No	Yes	Yes
Units	Temperature Units	°C	Yes	Yes	Yes
RTD Default Value	-200 through 850°C	26°C	No	Yes	Yes
Strategy	Never use default Use default on failure	Use default on failure	No	Yes	Yes
Level ^(a)					
Units	Level Units	Inch	Yes	Yes	Yes
Level LRV	Level LRV	0	Yes	Yes	Yes
Level URV	Level URV	100	Yes	Yes	Yes
Tank Dimensions	H1, H2, H3		No	Yes	Yes
Density ^(a)					
Units	Density Units	lb/ft ³	Yes	Yes	Yes
Density LRV	Density LRV	0	Yes	Yes	Yes
Density URV	Density URV	62	Yes	Yes	Yes
Other					
Enable Passwords for local display pushbuttons	No password, Configuration only locked, or Calibration and Configuration locked	No Password	Yes	No	No
Reset Database	Keep or Clear	Keep	Yes	No	No

(a) Numerous level and density configuration parameters must be set using the PCMV Configurator.

Calibration and Configuration Using a PCMV Field Device Configurator

To calibrate or configure the transmitter using a PCMV Field Device Configurator, follow the procedures in MI 020-497.

Calibration and Configuration Using a PC-Based Configurator

To calibrate or configure the transmitter using a PC-Based Configurator, follow the procedures in MI 020-505.

— NOTE

For limitations on using a PC-Based Configurator, see note on page 25.

Calibration and Configuration Using a HART Communicator

— NOTE

For limitations on using a HART Communicator, see note on page 25.

Online Menu

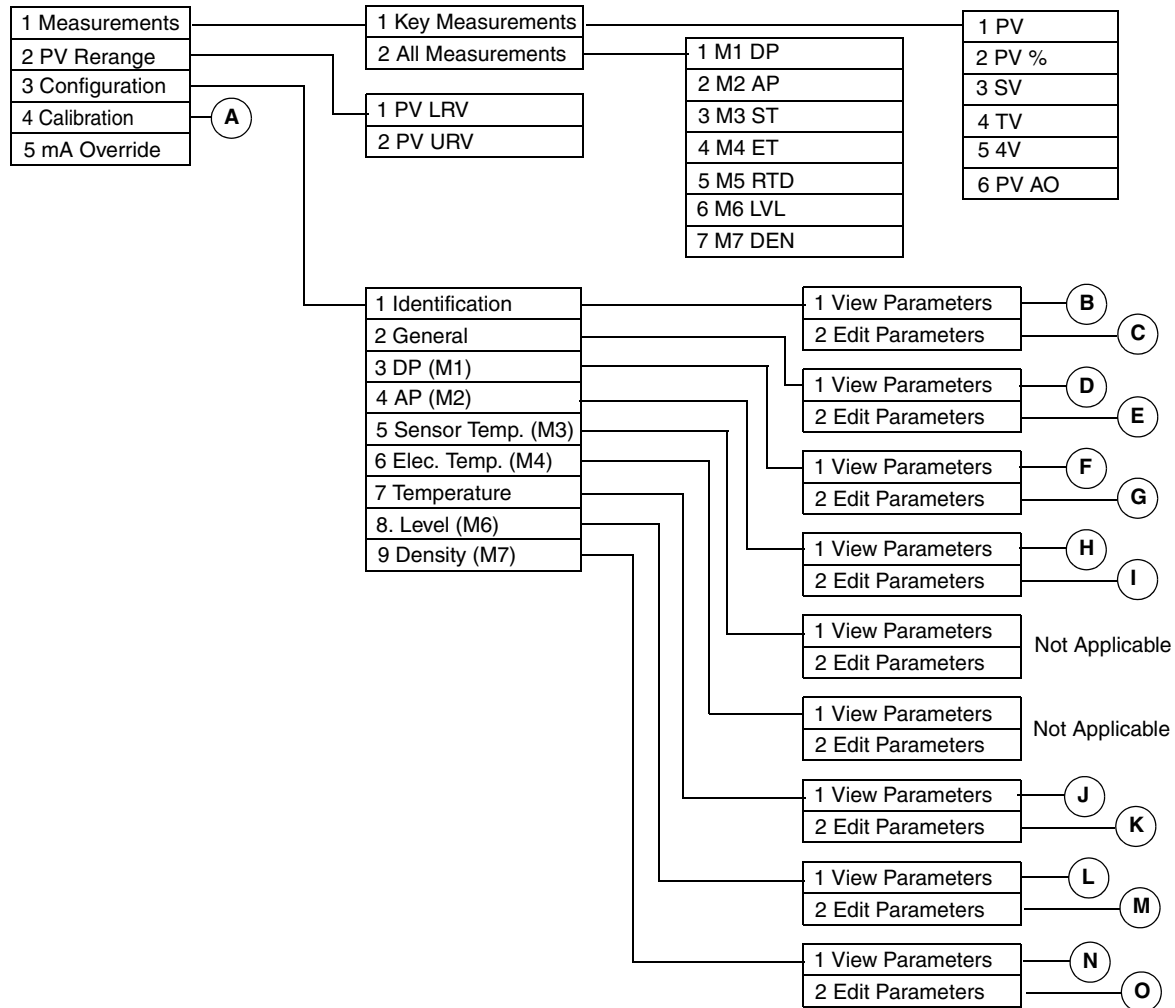

Figure 17. HART Communicator Online Menu (1 of 2)

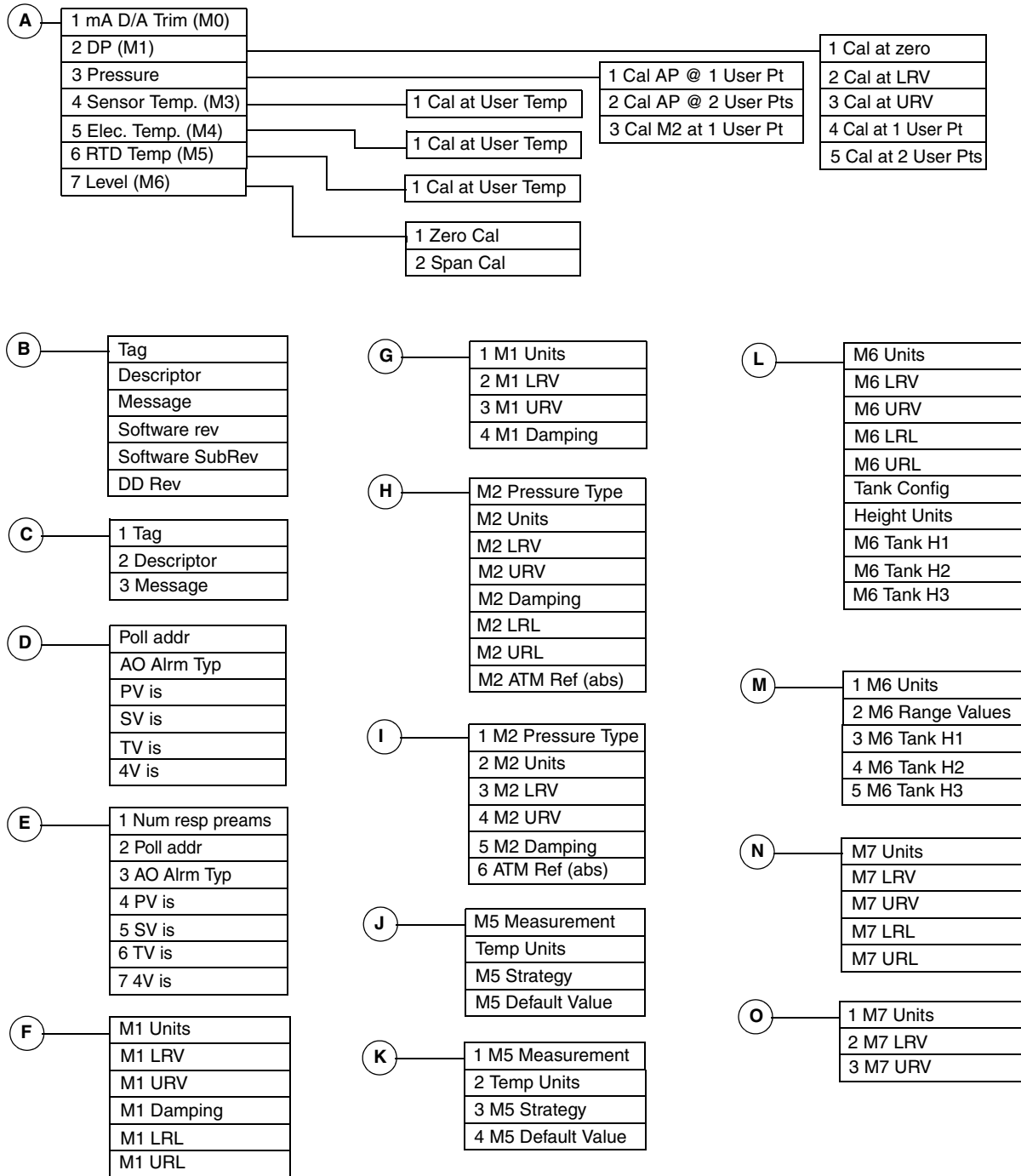

Figure 18. HART Communicator Online Menu (2 of 2)

Explanation of Parameters

Parameter	Fast-Key Path	Explanation
4V	1,1,5	Shows the value of fourth variable.
4V is	3,2,2,7	Select M1 DP, M2 AP, M3 Sens Temp, M4 Elec Temp, M5 RTD, M6 Level, or M7 Density.
All Measurements	1,2	Path to reading all measurements.
AO Alm Typ	3,2,2,3	Select Hi or Lo.
AP (M2)	3,4	Path to viewing or editing absolute pressure parameters.
ATM Ref (abs)	3,4,2,6	Enter the ambient atmospheric pressure. ^(a)
Cal AP @ 1 User Pt	4,3,1	Bench pressure calibration at 1 user determined point.
Cal AP @ 2 User Pts	4,3,2	Bench pressure calibration at 2 user determined points.
Cal at 1 User Pt	4,2,4	Differential pressure calibration at 1 user determined point.
Cal at 2 User Pts	4,2,5	Differential pressure calibration at 2 user determined points.
Cal at LRV	4,2,2	Differential pressure calibration at the lower range value.
Cal at URV	4,2,3	Differential pressure calibration at the upper range value.
Cal at User Temp	4,4,1 4,5,1 4,6,1	Calibration procedure for Sensor Temp. (M3). Calibration procedure for Electronic Temp. (M4). Calibration procedure for RTD Temp. (M5).
Cal at zero	4,2,1	Differential pressure calibration at zero pressure differential.
Cal M2 at 1 User Pt	4,3,3	One point pressure calibration done at the tank.
Calibration	4	Path to calibration procedures.
Configuration	3	Path to view or edit all parameters.
DD Rev	3,1,1	Path to view the DD revision level.
Density (M7)	3,9	Path to viewing or editing density parameters.
Descriptor	3,1,2,2	Edit Descriptor information.
DP (M1)	3,3	Path to viewing or editing differential pressure parameters.
DP (M1)	4,2	Path to differential pressure calibration procedures.
Edit Parameters	3,1,2 3,2,2 3,3,2 3,4,2 3,7,2 3,8,2 3,9,2	Edit identification parameter data Edit general parameter data. Edit differential pressure parameter data. Edit absolute pressure parameter data. Edit temperature parameter data. Edit level parameter data Edit density parameter data.
Elec. Temp. (M4)	3,6	Not used
Elec. Temp. (M4)	4,5	Electronic temperature calibration procedure.
General	3,2	Path to configuring poll address, AO Alarm type, and process variables.
Height Units	3,8,1	Shows the units of tank heights H1, H2, and H3.
Identification	3,1	Path to identification parameters.
Key Measurements	1,1	Path to reading key measurements.
Level (M6)	3,8	Path to viewing or editing level parameters.
Level (M6)	4,7	Path to level calibration procedures.

Parameter	Fast-Key Path	Explanation
M1 Damping	3,3,2,4	Enter the differential pressure damping value in seconds.
M1 DP	1,2,1	Shows the differential pressure measurement.
M1 LRL	3,3,1	Path to view the differential pressure lower range limit.
M1 LRV	3,3,2,2	Enter the differential pressure lower range value.
M1 Units	3,3,2,1	Select the differential pressure unit.
M1 URL	3,3,1	Path to view the differential pressure upper range limit.
M1 URV	3,3,2,3	Enter the differential pressure upper range value.
M2 AP	1,2,2	Shows the absolute pressure measurement.
M2 Damping	3,4,2,5	Enter the absolute pressure damping value in seconds.
M2 LRL	3,4,1	Path to view the absolute pressure lower range limit.
M2 LRV	3,4,2,3	Enter the absolute pressure lower range value.
M2 Pressure Type	3,4,2,1	Select Absolute or Gauge.
M2 Units	3,4,2,2	Select the absolute pressure unit.
M2 URL	3,4,1	Path to view the absolute pressure upper range limit.
M2 URV	3,4,2,4	Enter the absolute pressure upper range value.
M3 ST	1,2,3	Shows the sensor temperature measurement.
M4 ET	1,2,4	Shows the electronic temperature measurement.
M5 Default Value	3,7,2,4	Enter Default value.
M5 Measurement	3,7,2,1	Select On or Off.
M5 RTD	1,2,5	Shows the RTD measurement.
M5 Strategy	3,7,2,3	Select Never Use Default or Use Def. on RTD Fail.
M6 LRL	3,8,1	Path to view the level lower range limit.
M6 LRV	3,8,1	Path to view the level lower range value.
M6 LVL	1,2,6	Shows the level measurement.
M6 Range Values	3,8,2,2	Path to entering the level lower and upper range values.
M6 Tank H1	3,8,2,3	Enter the height from pressure tap to zero level point.
M6 Tank H2	3,8,2,4	Enter the height from transmitter connection to pressure tap.
M6 Tank H3	3,8,2,5	Enter the height from transmitter connection to top pressure connection.
M6 Units	3,8,2,1	Select the level unit.
M6 URL	3,8,1	Path to view the level upper range limit
M6 URV	3,8,1	Path to view the level upper range value
M7 DEN	1,2,7	Shows the density measurement.
M7 LRL	3,9,1	Path to view the density lower range limit.
M7 LRV	3,9,2,2	Enter the density lower range value.
M7 Units	3,9,2,1	Select the density unit.
M7 URL	3,9,1	Path to view the density upper range limit.
M7 URV	3,9,2,3	Enter the density upper range value
mA D/A Trim	4,1	Calibration procedure to match the 4-20 mA output to the calibration of the receiving device.
mA Override	5	Enter mA override value (3.6 to 21 mA)
Measurements	1	Path to all measurements.
Message	3,1,2,3	Edit Message information.

Parameter	Fast-Key Path	Explanation
Num resp preams	3,2,2,1	Enter number of preambles to be sent in a response message from the transmitter.
Poll addr	3,2,2,2	Specify 0 in standard point to point,2-wire analog mode. Specify an address from 1 through 15 for multidrop operation.
Pressure	4,3	Path to pressure calibration procedures.
PV	1,1,1	Shows the value of primary variable.
PV %	1,1,2	Shows the primary variable value in percent of range.
PV AO	1,1,6	Shows the analog output value of the primary variable.
PV is	3,2,2,4	Select M1 DP, M2 AP, M6 Level, or M7 Density.
PV LRV	2,1	Enter the lower range value.
PV Rerange	2	Path to setting PV LRV and PV URV.
PV URV	2,2	Enter the upper range value.
RTD Temp. (M5)	4,6	RTD temperature calibration procedure.
Sensor Temp. (M3)	3,5	Not used
Sensor Temp. (M3)	4,4	Sensor temperature calibration procedure.
Software rev	3,1,1	Path to view the software revision level.
Software SubRevision	3,1,1	Path to view the software subrevision level.
Span Cal	4,7,2	Span calibration procedure for Level (M6).
SV	1,1,3	Shows the value of secondary variable.
SV is	3,2,2,5	Select M1 DP, M2 AP, M3 Sens Temp, M4 Elec Temp, M5 RTD, M6 Level, or M7 Density.
Tag	3,1,2,1	Edit Tag information.
Tank Config	3,8,1	Shows the tank configuration type (boiler drum).
Temp Units	3,7,2,2	Select Kelvin, degC, degF, or degR.
Temperature	3,7	Path to viewing or editing temperature parameters.
TV	1,1,4	Shows the value of tertiary variable.
TV is	3,2,2,6	Select M1 DP, M2 AP, M3 Sens Temp, M4 Elec Temp, M5 RTD, M6 Level, or M7 Density.
View Parameters	3,1,1 3,2,1 3,3,1 3,4,1 3,7,1 3,8,1 3,9,1	Shows identification parameter data. Shows general parameter data. Shows differential pressure parameter data. Shows absolute pressure parameter data. Shows temperature parameter data. Shows level parameter data Shows density parameter data.
Zero Cal	4,7,1	Zero calibration procedure for Level (M6).

(a) Gauge pressure is equal to the atmospheric pressure minus the value entered in **ATM Ref**. It is not referenced to varying atmospheric pressure.

Calibration and Configuration Using the Optional Local Display

— NOTE

You can configure many parameters using the local display. However, for more complete configuration capability, including level and density configuration, use a PC-Based Configurator.

A local display, as shown in Figure 19, has two lines of information. The upper line is a 5-digit numeric display (4-digit when a minus sign is needed); the lower line is an 7-digit alphanumeric display. The display provides local indication of measurement information. The primary measurement is normally displayed. To view the secondary measurement, press the **Enter** button while in normal operating mode. To view the tertiary or fourth measurement, press the **Enter** button once or twice again. Press the **Next** or **Enter** button to return to the primary measurement. If power to the transmitter is interrupted, the display reverts to the primary display.

The display also provides a means for performing calibration and configuration, viewing the database, and testing the display via the 2-button keypad. You can access these operations by means of a multi-level menu system. Entry to the Mode Select menu is made (from normal operating mode) by pressing the **Next** button. You can exit this menu, restore your prior calibration or configuration, and return to the normal operating mode at any time by going to **Cancel** and pressing the **Enter** button.

The following items can be selected from this menu: Calibration (**CALIB**); Configuration (**CONFIG**); Viewing the database (**VIEW DB**); and Testing the display (**TST DSP**). The top level structure diagram is shown in Figure 20.

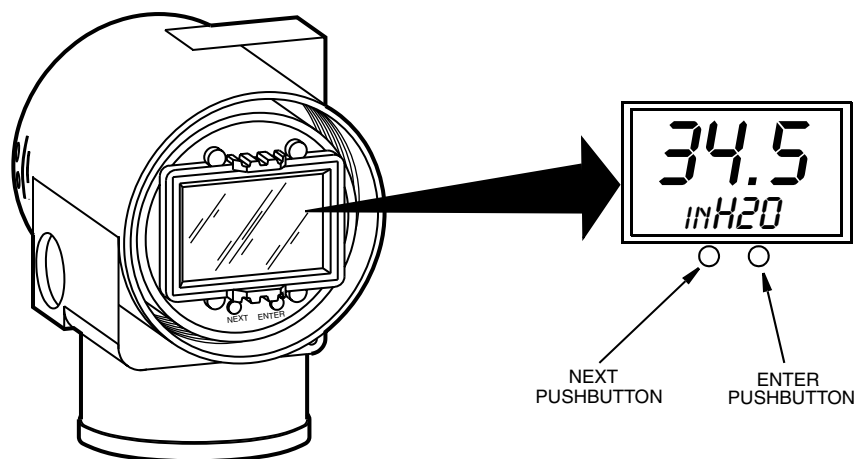

Figure 19. Local Display Module

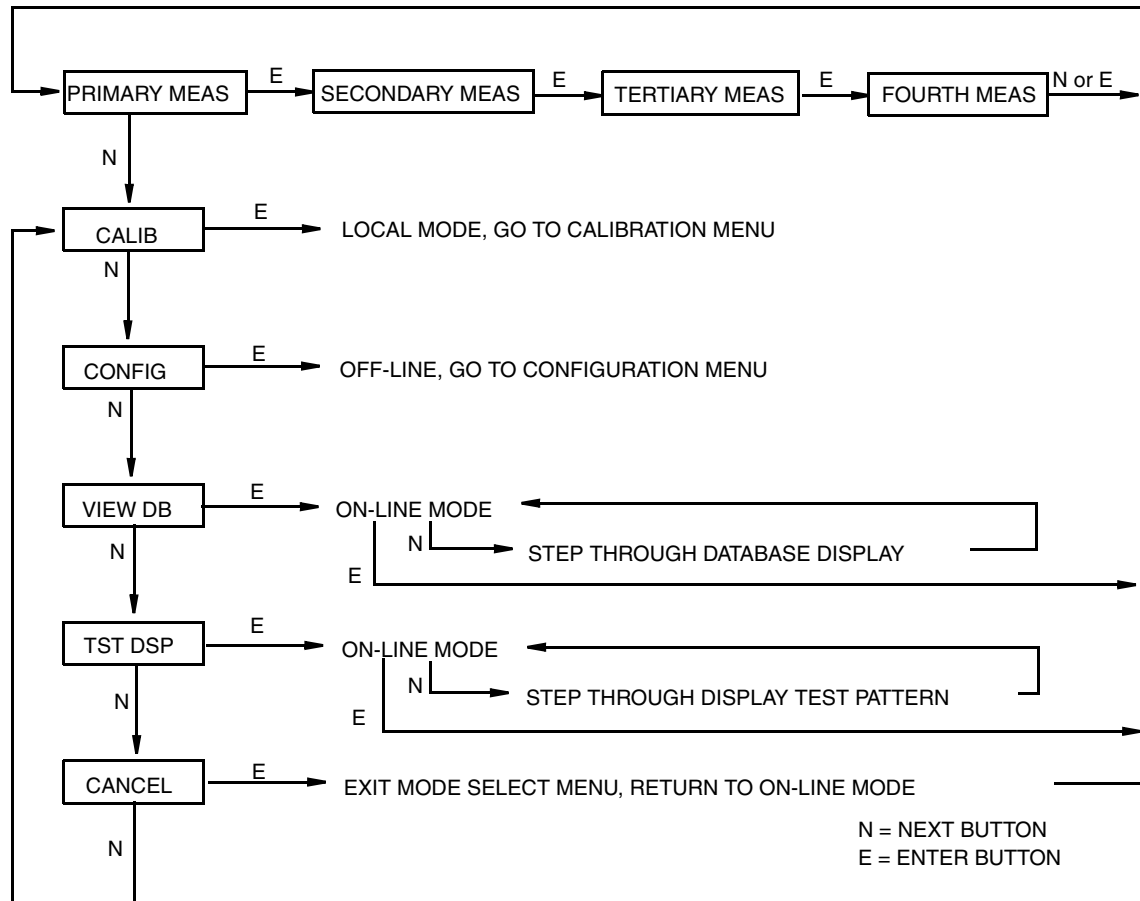

Figure 20. Top Level Structure Diagram

— **NOTE** —

In the Configuration menu and during adjustment of 4 and 20 mA in the Calibration menu, the milliampere output does not reflect live measurement values. Also, during Calibration and Configuration menu operations, the I/A Series system identifies all transmitter measurements as **BAD** because the transmitter is not in the on-line mode.

Entering Numerical Values

The general procedure for entering numerical values in Calibration and Configuration is as follows:

1. At the appropriate prompt, press the **Enter** button. The display shows the last (or default) value with the first digit flashing.
2. Use the **Next** button to select the desired first digit, then press the **Enter** button. Your selection is entered and the second digit flashes.
3. Repeat Step 2 until you have created your new value. If the number has less than five characters, use leading or trailing zeros for the remaining spaces. When you have configured the fifth space, the display prompts you to place the decimal point.

4. Move the decimal point with the **Next** button until it is where you want it and press the **Enter** button.

— **NOTE** —

1. The decimal point can not be placed directly after the first digit. For example, you can not enter a value as 1.2300; you must enter it as 01.230.
 2. The decimal position is identified by flashing except at the position after the fifth digit. At that position (representing a whole number), the decimal point is assumed.
-

5. The display advances to the next menu item.

Calibration

To access the Calibration mode (from the normal operating mode), press the **Next** button. The display reads **CALIB**, the first item on the menu. Acknowledge your choice of this selection by pressing the **Enter** button. The display shows the first item in the Calibration menu. You can then calibrate the items shown in Table 6.

— **NOTE** —

1. If calibration has been configured as password protected, you are asked to enter the password before you can proceed.
 2. If your transmitter is write protected, you cannot write your calibration to the electronics. To disable this feature, see “Setting the Write Protect Jumper” on page 16.
-

Table 6. Calibration Menu

Item	Description
CAL PWD	Enter password if required.
CAL LVL	Calibrate level
CAL DP	Calibrate differential pressure.
CAL AP	Calibrate absolute pressure.
CAL RTD	Calibrate the RTD.
CAL STMP	Calibrate sensor temperature.
CAL ETMP	Calibrate electronics temperature.
CAL mA	Adjust nominal 4 mA and 20 mA output (D/A converter trim).
RERANGE	Set primary upper and lower range values.
CALDATE	Enter the calibration date.
CAL LVL causes the following two submenus:	
CALZERO	Enter desired level output value at current tank level (<1/3 full level span).
CALSPAN	Enter desired level output value at current tank level (>2/3 full level span)
CAL DP causes the following three submenus:	

Table 6. Calibration Menu (Continued)

Item	Description
CALDP 0	Calibrate with zero differential pressure.
CALDPLR	Calibrate with differential pressure at 0% of transmitter range. (LRV)
CALDPUR	Calibrate with differential pressure at 100% of transmitter range. (URV)
CAL AP causes the following two submenus:	
1PntCAL	Calibrate at one point with pressure applied
2PntCAL	Calibrate at two points with pressures applied
CAL RTD causes the following submenu:	
ADJTEMP	Edit current RTD temperature.
CAL STMP causes the following submenu:	
ADJTEMP	Edit current STMP temperature.
CAL ETMP causes the following submenu:	
ADJTEMP	Edit current ETMP temperature.
CAL mA causes the following two submenus:	
ADJ 4 mA	Adjust the 4 mA output.
ADJ20mA	Adjust the 20 mA output
RERANGE causes the following two submenus	
LRV	Set lower range value
URV	Set upper range value

— NOTE —

It is not recommended to use the **CAL mA** menu selections unless there is a plant requirement to make the upper and lower calibration values exactly match readings on certain plant calibration equipment and the **CAL LVL**, **CAL DP**, or **CAL AP** operations result in a small but unacceptable difference between the transmitter mA output and the test equipment mA readout values.

Proceed to calibrate your transmitter by using the **Next** button to select your item and the **Enter** button to specify your selection per Figure 22. At any point in the calibration, you can **Cancel**, restore your prior calibration and return to the online mode or **Save** your new calibration. Calibration error messages are listed in Table 8.

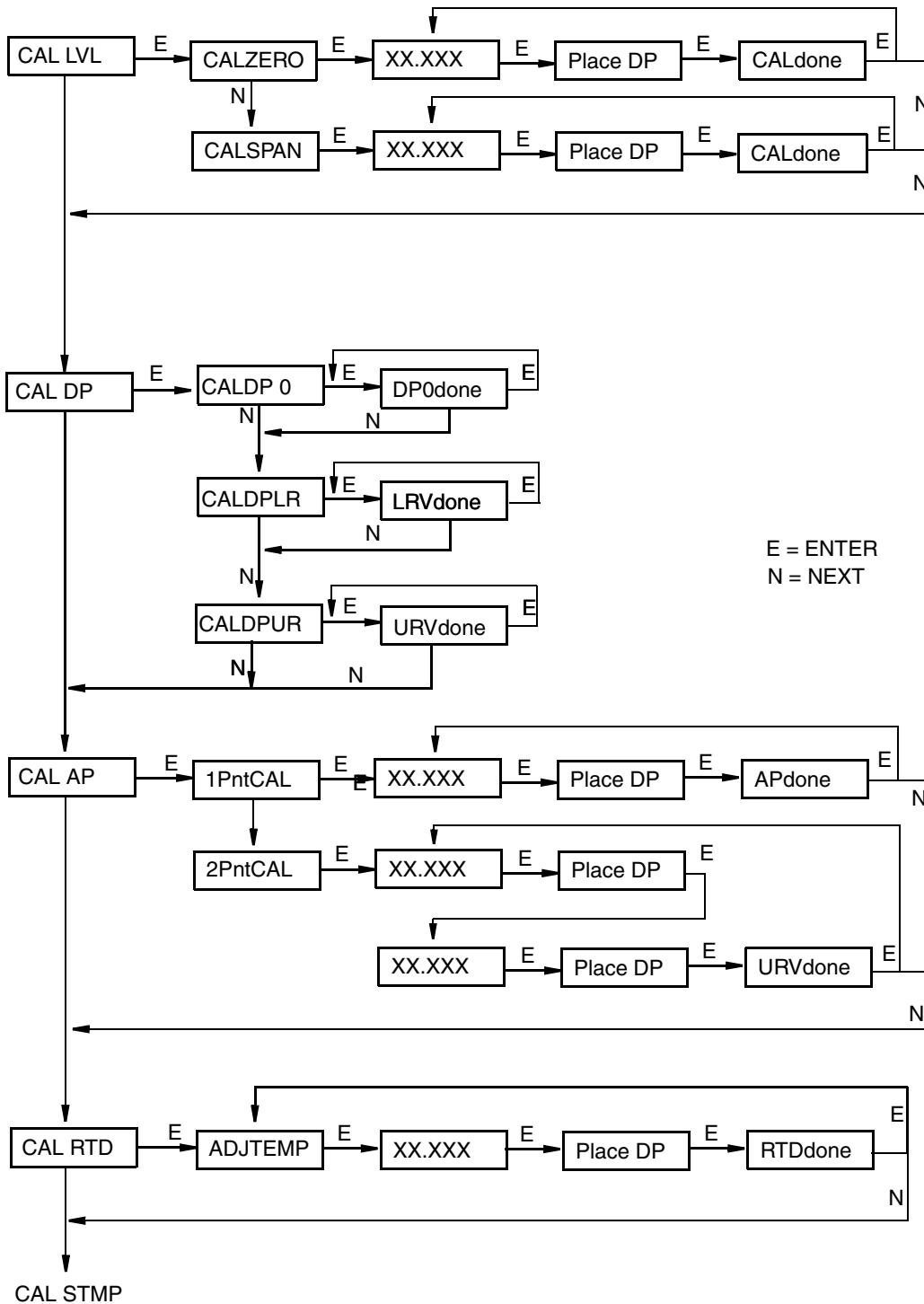

Figure 21. Calibration Structure Diagram (1 of 3)

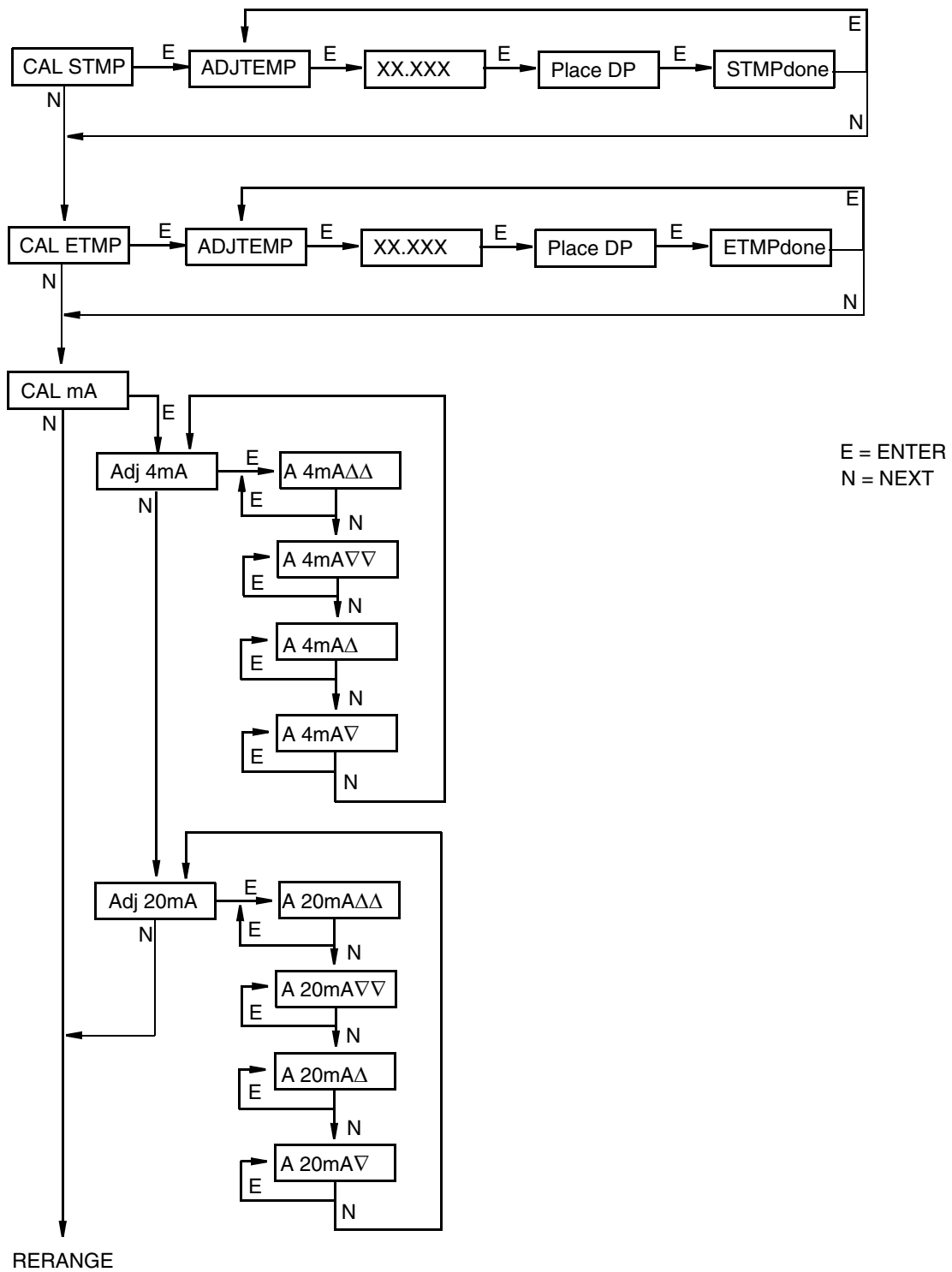
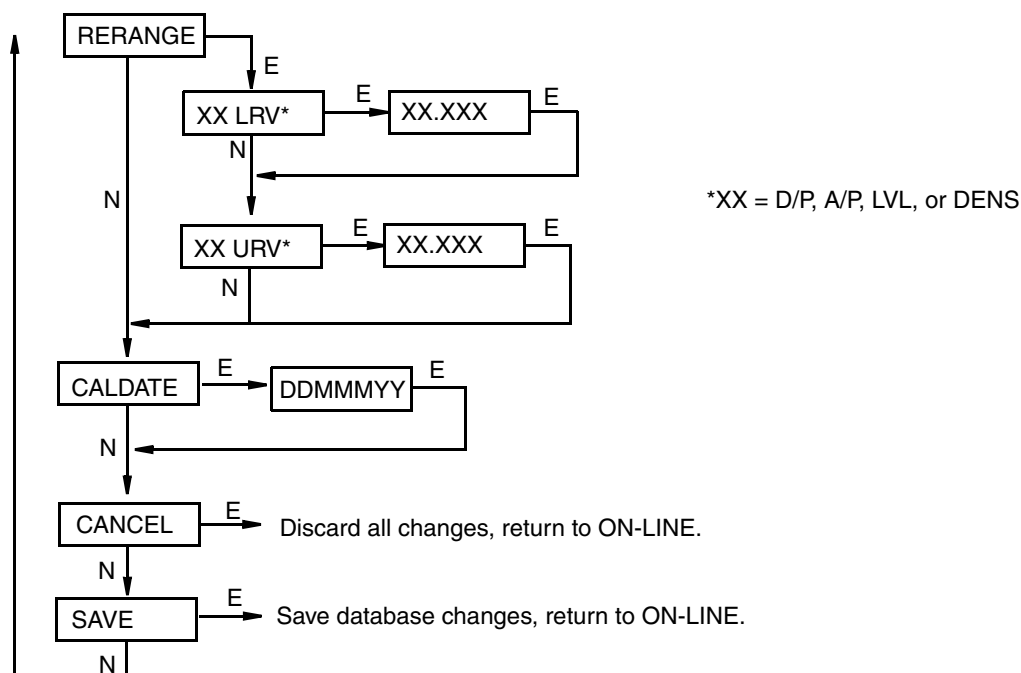

Figure 22. Calibration Structure Diagram (2 of 3)



Calibration Structure Diagram (3 of 3)

Commentary on Figure 22

CAL LVL

Level calibration is a field calibration procedure. To calibrate the level measurement, press **Enter** at the display of **CAL LVL**. Then, using the **Next** button, select **CALZERO** or **CALSPAN**.

To do a zero calibration, at the display **CALZERO**, press **Enter**. Enter the desired output value at the current tank level (less than 1/3 of the full level span) and place the decimal point. Press **Enter**. Wait while the transmitter is calibrated. Completion is indicated by the display **CALdone**. Press **Enter** twice to repeat or **Next** to move to **CAL DP**.

To do a span calibration, at the display **CALSPAN**, press **Enter**. Enter the desired output value at the current tank level (greater than 2/3 of the full level span) and place the decimal point. Press **Enter**. Wait while the transmitter is calibrated. Completion is indicated by the display **CALdone**. Press **Enter** twice to repeat or **Next** to move to **CAL DP**.

CAL DP

To calibrate the differential pressure measurement, press **Enter** at the display of **CAL DP**. Then, using the **Next** button, select **CALDP 0**, **CALDPLR**, or **CALDPUR**.

To set or reset the zero point at zero pressure, apply zero differential pressure to the transmitter and, at display of **CALDP 0**, press **Enter**. This can be done whether LRV is zero or not. Completion is indicated by the display **DP0done**. Press **Enter** twice to repeat or **Next** to move to **CALDPLR**.

To set or reset 0% of range input, apply differential pressure to the transmitter equal to the Lower Range Value (LRV) in the transmitter data base and, at display of **CAL DP LR**, press **Enter**. Completion is indicated by the display **LRVdone**. Press **Enter** twice to repeat or **Next** to move to **CALDPUR**.

To set or reset 100% of range input, apply differential pressure to the transmitter equal to the Upper Range Value (URV) in the transmitter database and, at display of **CALDPUR**, press **Enter**. Completion is indicated by the display **URVdone**. Press **Enter** twice to repeat or **Next** to move to **CAL AP**.

CAL AP

To calibrate the pressure measurement, press **Enter** at the display of **CAL AP**. Then, using the **Next** button, select **1PntCAL** or **2PntCAL**.

To do a 1-point calibration, at the display **1PntCAL**, press **Enter**. At the prompt **Apply AP**, apply an absolute pressure (such as atmospheric pressure) and press **Enter**. Enter that pressure and place the decimal point. Wait while the transmitter is calibrated.

Completion is indicated by the display **APdone**. Press **Enter** twice to repeat or **Next** to move to **CAL RTD**.

To do a 2-point calibration, at the display **2PntCAL**, press **Enter**. At the prompt **Apply AP**, apply the lower of two absolute pressures and press **Enter**. Enter that pressure and place the decimal point. Wait while the transmitter is calibrated. Completion is indicated by the display changing to **Apply AP**. Apply the higher of two absolute pressures and press **Enter**. Enter that pressure on the display and place the decimal point. Wait while the transmitter is calibrated. Completion is indicated by the display changing to **URVdone**. Press **Enter** twice to repeat or **Next** to move to **CAL RTD**.

CAL RTD

To edit the current RTD temperature, at the display **CAL RTD**, press **Enter**. At the display **ADJTEMP**, press **Enter** again. Enter the temperature you desire and place the decimal point. Press **Enter**. Completion is indicated by the display **RTDdone**. Press **Enter** to repeat or **Next** to move to **CAL STMP**.

CAL STMP

To edit the current sensor temperature, at the display **CAL STMP**, press **Enter**. At the display **ADJTEMP**, press **Enter** again. Enter the temperature you desire and place the decimal point. Press **Enter**. Completion is indicated by the display **STMPdone**. Press **Enter** to repeat or **Next** to move to **CAL ETMP**.

CAL ETMP

To edit the current electronic temperature, at the display **CAL ETMP**, press **Enter**. At the display **ADJTEMP**, press **Enter** again. Enter the temperature you desire and place the decimal point. Press **Enter**. Completion is indicated by the display **ETMPdone**. Press **Enter** to repeat or **Next** to move to **CAL mA**.

CAL mA

If you configured your transmitter operating mode as 4 to 20 mA, you can adjust the 4 mA and 20 mA output by going to **CAL mA**, using the **Next** button and pressing **Enter**.

To increase the 4 mA output by a large (0.025 mA) step, press **Enter** at the display **A 4mA $\Delta\Delta$** . To decrease it by a large step, go to the display **A 4mA $\nabla\nabla$** by pressing the **Next** button and then **Enter**. To increase it by a small (0.001 mA) step, go to the display **A 4mA Δ** with the **Next** button and then press **Enter**. To decrease it by a small step, go to the display **A 4mA ∇** with the **Next** button and then press **Enter**.

ADJ20mA

Similar to ADJ 4mA.

RERANGE

You can adjust 100% and 0% range values of the primary measurement (defined in **MX MAP**). To do this, go to **RERANGE** with the **Next** button and press **Enter**. You can then adjust **XX URV** and/or **XX LRV** (where XX = D/P, A/P, LVL, or DENS) in the following two submenus.

CALDATE

This is not a required entry but can be used for recordkeeping or plant maintenance purposes. To edit the calibration date, go to **CALDATE** with the **Next** button and press **Enter**. You then can change the day, month, and year. The display shows the last date with the day flashing. Use the **Next** button to step through the menu of digits to select the desired day, then press **Enter**. Repeat this process for the month and year.

Configuration

You can access the Configuration mode by the same multi-level menu system that was used to enter Calibration mode. Entry to the Mode Select menu is made (from normal operating mode) by pressing the **Next** button. The display reads **CALIB**, the first item on the menu. Press the **Next** button again to get to the second item on the menu, **CONFIG**. Acknowledge your choice of this selection by pressing the **Enter** button. The display shows the first item in the Configuration menu. You can then configure items shown in Table 7. The standard factory default configuration is also given in this table.

The standard factory default configuration is not used if custom configuration option -C2 has been specified. Option -C2 is a full factory configuration of all parameters to the user's specifications.

— NOTE —

1. If configuration has been password protected, you are asked to enter the password before you can proceed.
 2. If your transmitter is write protected, you cannot write your configuration to the electronics. To disable this feature, see "Setting the Write Protect Jumper" on page 16.
-

Table 7. Configuration Menu

Item	Description	Initial Factory Configuration
CFG PWD	Alpha entry unless PWD ENA = NO PWDS	- - -
POLLADR	Poll Address from 0 to 15	0
MX MAP	Configure measurements/calculations to be displayed	- - -
PV=	Primary Measurement = D/P, A/P, LVL, or Density	Level
SV=	Secondary Measurement = D/P, A/P, STMP (Sensor Temp), ETMP (Electronics Temp), RTD, LVL, or Density	D/P
TV=	Tertiary Measurement = D/P, A/P, STMP (Sensor Temp), ETMP (Electronics Temp), RTD, LVL, or Density	A/P
4V=	Fourth Measurement = D/P, A/P, STMP (Sensor Temp), ETMP (Electronics Temp), RTD, LVL, or Density	RTD
CFG MA	Configure mA output parameters	- - -
OUT DIR	4 to 20 mA Output; forward or reverse	Forward
OUTFAIL	4 to 20 mA Output; fail mode output - low or high	High
OFFL MA	4 to 20 mA Output in off-line mode - last or user set	USER MA
USER MA	Off-line mA value; between 4 and 20 mA	4 mA
CFG DP	Configure D/P parameters	- - -
DP EGU	User-Defined Engineering Units	inH2O
D/P LRV	M1 Lower Range Value	Depends on Range
D/P URV	M1 Upper Range Value	Depends on Range
DAMPING	Damping: none, 1/4, 1/2, 1, 2, 4, 8, 16, or 32 seconds	None
CFG AP	Configure A/P parameters	- - -
AP MODE	Display AP or GP	AP
AP EGU	User Defined Engineering Units	psi
A/P LRV	A/P Lower Range Value	Depends on Range
A/P URV	A/P Upper Range Value	Depends on Range
ATM REF	Atmosphere Reference	14.7
DAMPING	Damping: none, 1/4, 1/2, 1, 2, 4, 8, 16, or 32 seconds	None
TMP EGU	User-Defined Engineering Units	°C
CFG LVL	Configure Level parameters	- - -
LVL EGU	User-Defined Engineering Units	inch
LVL LRV	Level Lower Range Value	0
LVL URV	Level Upper Range Value	100
CFGDENS	Configure density parameters	- - -
DENSEGU	User-Defined Engineering Units	lb/ft3
DENSLRV	Density Lower Range Value	0
DENSURV	Density Upper Range Value	62

Table 7. Configuration Menu (Continued)

Item	Description	Initial Factory Configuration
CALDATE	Calibration Date	- - -
ENA PWD	Enable password: no password, configuration only, or configuration and calibration	NO PWDS
CFG PWD	User-set configuration password (six characters)	- - -
CAL PWD	User-set calibration password (six characters)	- - -
RESET DB	Rewrites all calibration and configuration values with default values	Keep

Proceed to configure your transmitter by using the **Next** button to select your item and the **Enter** button to specify your selection per Figure 23. At any point in the configuration you can **Cancel** your changes and return to the on-line mode, or **Save** your changes.

Configuration error messages are listed in Table 9.

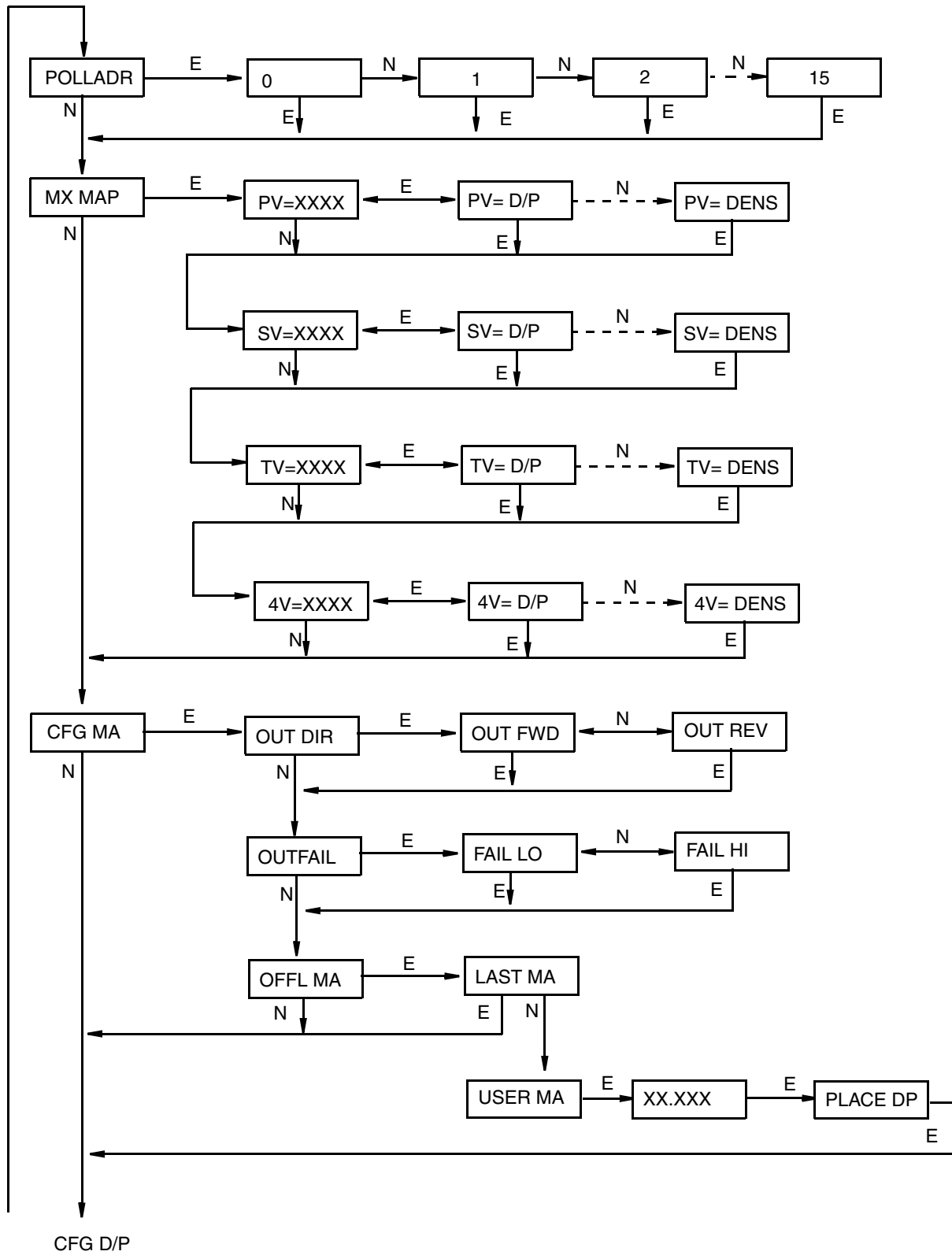
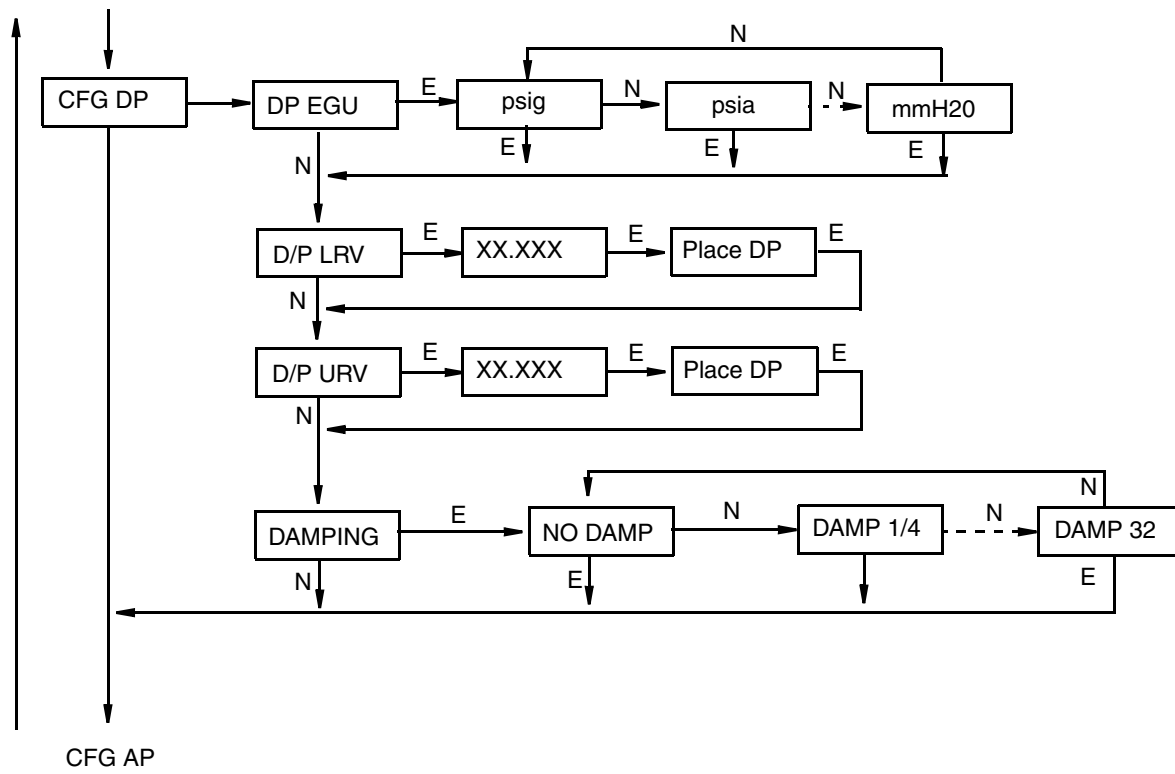
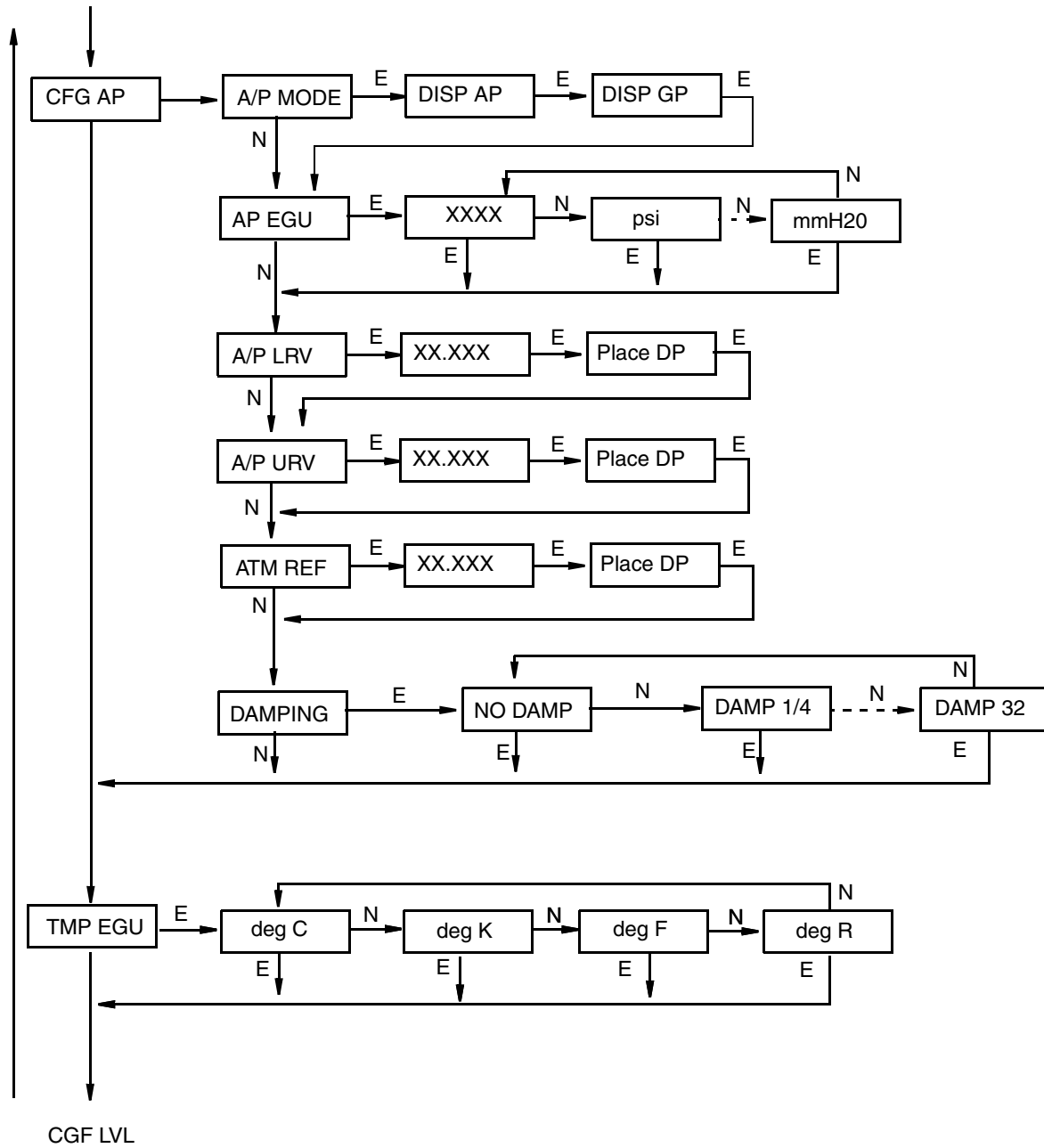

Figure 23. Configuration Structure Diagram (1 of 5)



Configuration Structure Diagram (2 of 5)



Configuration Structure Diagram (3 of 5)

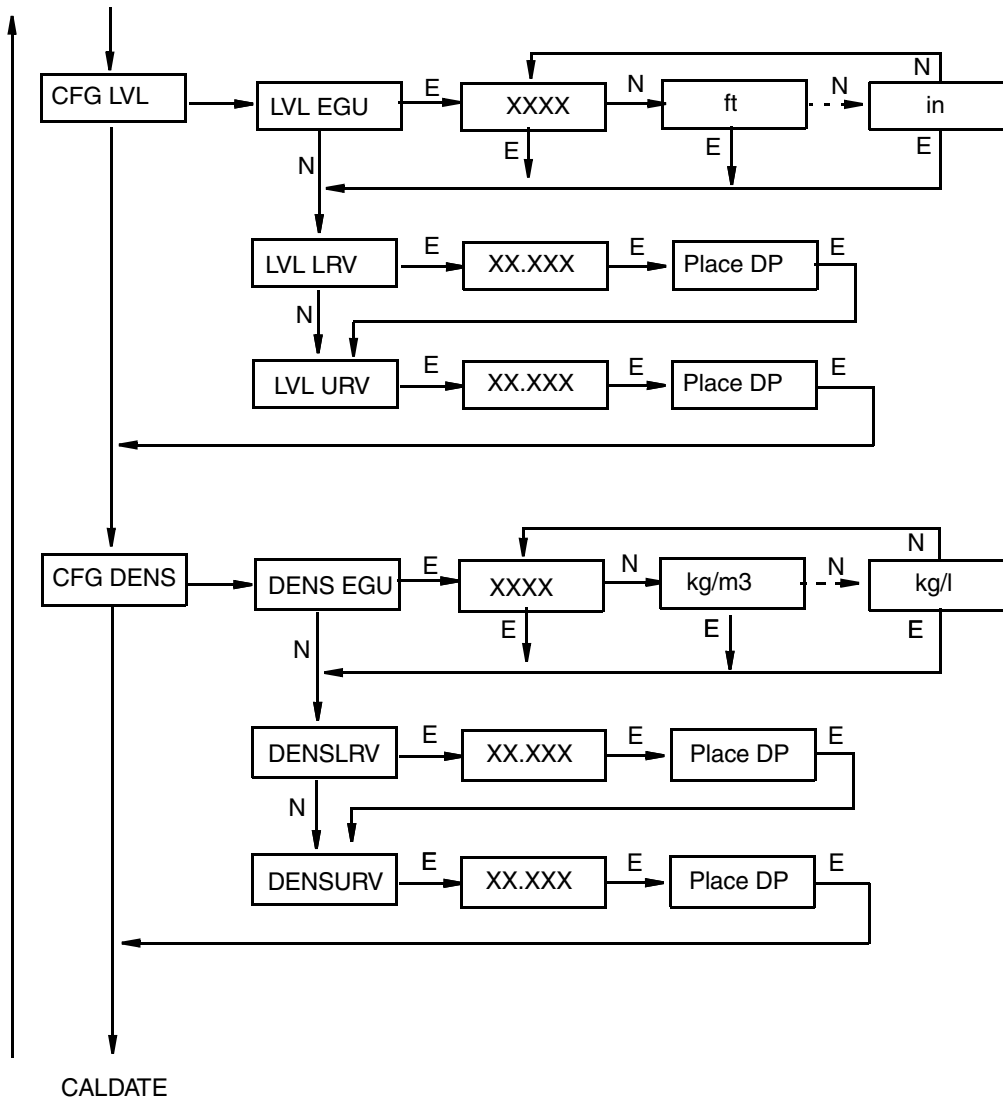

Configuration Structure Diagram (4 of 5)

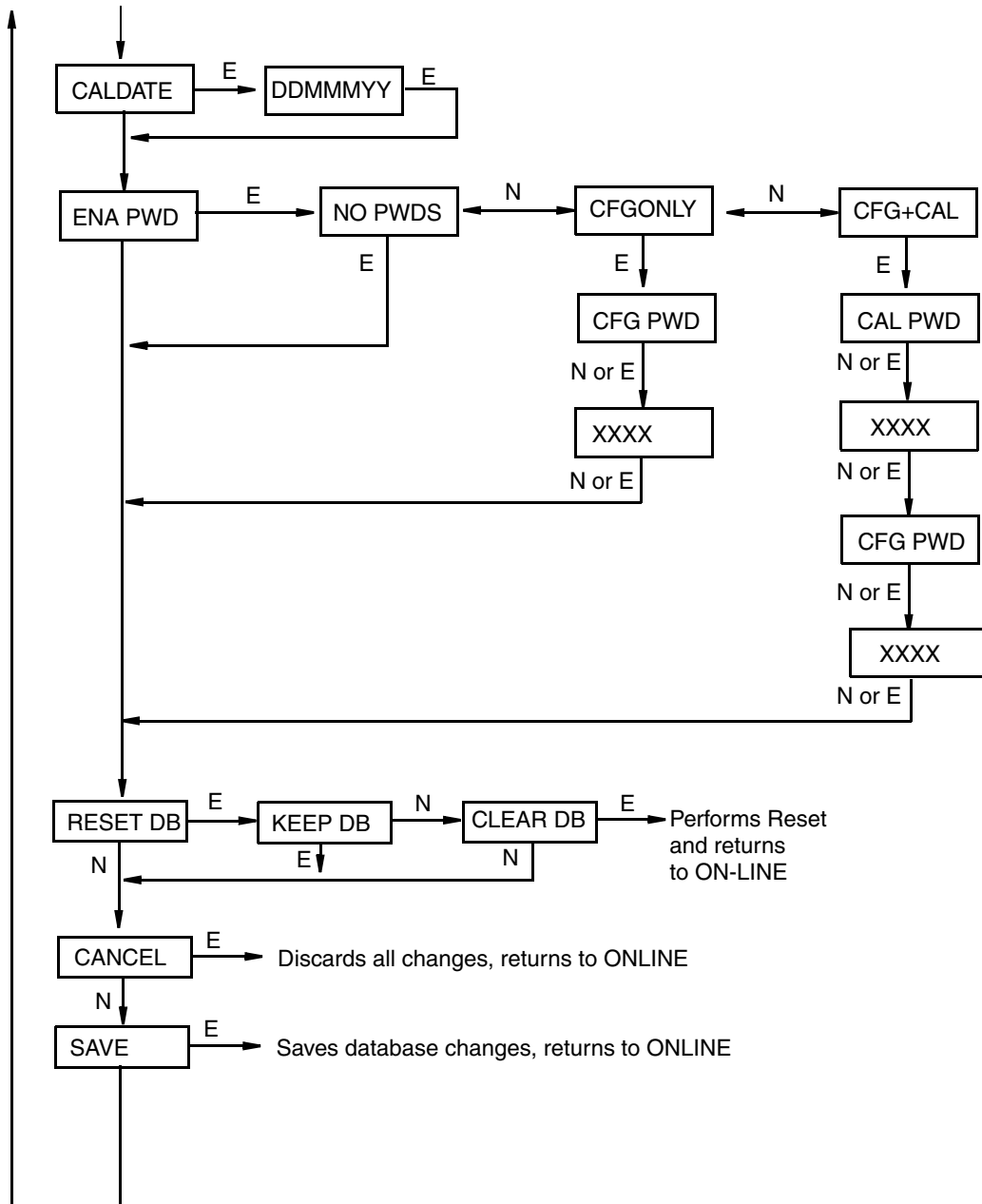

Configuration Structure Diagram (5 of 5)

Commentary on Figure 23

In general, use the **Next** button to select your item and the **Enter** button to specify your selection.

POLLADR

To configure the transmitter poll address, press **Enter**. Use the **Next** button to select an address of **0** through **15** and press **Enter**.

MX MAP

To configure the four measurements or calculations to be displayed, go to **MX MAP** with the **Next** button and press **Enter**. Use the **Next** button to select the primary measurement, **PV=xxxx**; the secondary measurement, **SV=xxxx**; the tertiary measurement, **TV=xxxx**; or the fourth measurement, **4V=xxxx** and press **Enter**. The current configuration blinks. Use the **Next** button to select the measurement or calculation for the display indicated and press **Enter**.

CFG MA

To configure the mA output, go to **CFG MA** with the **Next** button and press **Enter**. The first parameter, **OUT DIR**, is displayed.

To configure the output direction, go to **OUT DIR** with the **Next** button and press **Enter**. Use the **Next** button to select **OUT FWD** (4 to 20 mA) or **OUT REV** (20 to 4 mA) and press **Enter**.

The Outfail feature provides high or low output with certain malfunctions. To configure the fail mode output, go to **OUTFAIL** with the **Next** button and press **Enter**. Use the **Next** button to select **FAIL LO** (3.6 mA) or **FAIL HI** (22 mA) and press **Enter**.

The Offline mA feature enables you to set the output to a specified value or to the last value if the transmitter goes off-line. To configure the off-line output, go to **OFFL MA** with the **Next** button and press **Enter**. Use the **Next** button to select **LAST MA** or **USER MA** and press **Enter**. If you selected **USER MA**, press **Enter** again at the display of digits. Then use the **Next** button to step through the library of digits to select the desired first digit, then press **Enter**. Your selection is entered and the second character flashes. Repeat this procedure until you have entered the last digit. Then use the **Next** button to move the decimal point to its desired location and press **Enter**. The display advances to the next menu item.

CFG DP

To configure the differential pressure measurement, go to **CFG DP** with the **Next** button and press **Enter**. The first parameter, **DP EGU**, is displayed.

To configure engineering units for your display and transmission, specify one of the following units: **psi**, **inHg**, **FtH2O**, **inH2O**, **atm**, **bar**, **mbar**, **MPa**, **kPa**, **Pa**, **kgcm2**, **gcm2**, **cmHg**, **mmHg**, **torr**, **mH2O**, **cmH2O**, or **mmH2O**. Next, you must set the **DP LRV** (lower range value) and the **D/P URV** (upper range value).

To configure additional damping, go to **DAMPING** with the **Next** button and press **Enter**. Use the **Next** button to select **NO DAMP**, **DAMP 1/4**, **DAMP 1/2**, **DAMP 1**, **DAMP 2**, **DAMP 4**, **DAMP 8**, **DAMP 16**, or **DAMP 32** and press **Enter**.

CFG AP

To configure the pressure measurement, go to **CFG AP** with the **Next** button and press **Enter**. The first parameter, **AP MODE**, is displayed.

To configure the absolute pressure mode, press **Enter**. Then use the **Next** button to select **DISP AP** (absolute pressure) or **DISP GP** (gauge pressure) and press **Enter**.

To configure engineering units for your display and transmission, go to **AP EGU** and press **Enter**.

You are asked to specify one of the following labels: **psi, inHg, FtH2O, inH2O, atm, bar, mbar, MPa, kPa, Pa, kgcm2, gcm2, cmHg, mmHg, torr, mH2O, cmH2O, or mmH2O**. Then, set the **DP LRV** (lower range value) and the **A/P URV** (upper range value).

If **AP MODE** is configured **DISPGP**, you must configure the atmospheric reference. To do this, go to **ATM REF** and press **Enter**. Enter the desired value and press **Enter**.

TMP EGU

To configure the temperature units, go to **TMP EGU** with the **Next** button and press **Enter**. Use the **Next** button to select **deg C, deg K, deg F, or deg R**. Press **Enter**.

CFG LVL

To configure the level calculation, go to **CFG LVL** with the **Next** button and press **Enter**. The first parameter, **LVL EGU**, is displayed.

To configure engineering units for your display and transmission, specify one of the following labels: **ft, mm, cm, m, or in**. Lastly, set the **LVL LRV** (lower range value) and **LVL URV** (upper range value).

CFG DENS

To configure the density measurement, go to **CFGDENS** with the **Next** button and press **Enter**. The first parameter, **DENSEGU**, is displayed.

To configure engineering units for your display and transmission, specify one of the following labels: **kg/m3, g/cm3, oz/in3, lb/ft3, lb/yd3, LT/yd3, ST/yd3, lb/gal, or kg/l**. Then, set the **DENSLRV** (lower range value) and **DENSURV** (upper range value).

CALDATE

This is not a required entry but can be used for recordkeeping or plant maintenance purposes. To edit the calibration date, go to **CALDATE** with the **Next** button and press **Enter**. You then can change the day, month, and year. The display shows the last date with the day flashing. Use the **Next** button to step through the library of digits to select the desired day, then press **Enter**. Repeat this process for the month and year.

ENA PWD

To enable or disable the password feature, go to **ENA PWD** with the **Next** button and press **Enter**. Use the **Next** button to select **NO PWDS** (password feature disabled), **CFGONLY** (password required to configure only), or **CFG+CAL** (password required to both configure and calibrate) and press **Enter**.

If you selected **CFG ONLY**, the display changes to **CFG PWD**. Press either the **Next** or **Enter** button. Use the **Next** button to step through the library of characters to select the desired first character, then press **Enter**. Your selection is entered and the second character flashes. Repeat this procedure until you have created your password. If the password has less than six characters, use blanks for the remaining spaces. When you have configured the sixth space, the display advances to the next menu item.

If you selected **CFG+CAL**, the display changes to **CAL PWD**. To create the Calibration password, press either the **Next** or **Enter** button. Use the **Next** button to step through the library of characters to select the desired first character, then press **Enter**. Your selection is entered and the second character flashes. Repeat this procedure until you have created

your password. If the password has less than six characters, use blanks for the remaining spaces. When you have configured the sixth space, the display advances to **CFG PWD**. Use the same procedure to create the configuration password.

! CAUTION

Record your new password before saving changes to the database.

RESET DB

Do **not** use this parameter. It is for Invensys use only.

Viewing the Database

You can access the View Database mode by the same multi-level menu system that was used to enter Calibration and Configuration mode. Access to **View DB** is made (from normal operating mode) by pressing the **Next** button three times. Acknowledge your choice of this selection by pressing the **Enter** button. The first item on the view database menu is the firmware version, **FMW REV**. Pressing the **Next** button repeatedly steps you through the database. You can abort this procedure at any time by pressing the **Enter** button.

Testing the Display

You can access the Test Display mode by the same multi-level menu system that was used to enter Calibration, Configuration, and View Database mode. Entry to the Mode Select menu is made (from normal operating mode) by pressing the **Next** button. The display reads **CALIB**, the first item on the menu. Press the **Next** button three times to get to the fourth item on the menu, **TST DSP**. Acknowledge your choice of this selection by pressing the **Enter** button. The display shows the first test segment pattern. You can step through the five patterns by repeated use of the **Next** button. You can abort the test at any time by pressing the **Enter** button.

Error Messages

Table 8. Calibration Error Messages

Parameter	Condition Tested	Error Message	User Action
Password Protection	Password	BAD PWD	Bad password entered, use another.
Write Protection	Write protection enabled	REJECT	Displays when you attempt an action that is write protected.
CAL LVL	Zero calibration value is greater than 1/3 of range	VAL>1/3	Use zero calibration point in lower 1/3 of range.
	Span calibration value is less than 2/3 of range.	VAL<2/3	Use span calibration point in upper 1/3 of range.

Table 8. Calibration Error Messages (Continued)

Parameter	Condition Tested	Error Message	User Action
CAL DP or CAL AP	Calculated offset too large	BADZERO	Check applied pressure and configured LRV.
	Calculated slope too large or too small	BADSPAN	Check applied pressure and configured URV.
	M1 or M2 slope = 0	BAD UDB	Redo calibration with different upper value.
	Completion of data collection	CALWAIT	Displayed while data is collected for calibration.
	Measurement Status Error	BADSTAT	If AP, check that calibrating pressure (or vent) is applied to both high and low pressure sides simultaneously.
CAL RTD ADJTEMP	Calculated offset too large	BADOFST	Check RTD connections. Adjustment limited to 0.05% of range.
	Completion of data collection	CALWAIT	Displayed while data is collected for calibration.
	Measurement Status Error	BADSTAT	Check RTD wiring.
	RTD Mode	MEASOFF	Calibration attempt fails when RTD is configured Off.
RERANGE	LRV > max pressure in EGU	LRV>FMX	Entered pressure is greater than maximum rated pressure of transmitter. Check entry. Verify EGUs.
	LRV < min pressure in EGU	LRV<FMN	Entered pressure is less than minimum rated pressure of transmitter. Check entry. Verify EGUs.
	URV = LRV	LRV=URV	Cannot set span to 0. Check entry. Check URV. Verify EGU.
	Calculated turndown exceeds limit	BADTDWN	Span too small. Check entry. Check URV. Verify EGU.
A4MA	Adjustment exceeds maximum/minimum limit	HILIMIT LOLIMIT	Check loop resistance.
A20MA	Adjustment exceeds maximum/minimum limit	HILIMIT LOLIMIT	Check loop resistance.

Table 9. Configuration Error Messages

Parameter	Condition Tested	Error Message	User Action
Any Configuration Action	Calculation Delay	WAIT	Displayed temporarily during calculation of updated values that result from a configuration change. No user action is necessary.
Password Protection	Password	BAD PWD	Bad password entered, use another.
Write Protection	Write Protection Enabled	REJECT	Displays when user attempts an action that is write protected.
AP MODE (changing DISP GP or DISP AP)	Adjusted LRV is too large to display	LRV>DSP	EGU must be changed if you want to edit LRV value on display.
	Adjusted URV is too large to display	URV>DSP	EGU must be changed if you want to edit URV value on display.
ATM REF (in CFG AP)	ATM REF too high	ATM>20	ATM REF must be set below 20 psia.
	ATM REF too low	ATM<10	ATM REF must be set above 10 psia.
CFG any (entering URV)	M1URV > max pressure in EGU	URV>FMX	Entered pressure is greater than maximum rated pressure of transmitter. Check entry. Verify EGUs.
	M1URV < min pressure in EGU	URV<FMN	Entered pressure is less than minimum rated pressure of transmitter. Check entry. Verify EGUs.
	Entered URV value = LRV value	LRV=URV	Cannot set span to 0. Check entry. Check LRV. Verify EGU.
	Calculated turndown exceeds limit	BADTDWN	Span too small. Check entry. Check LRV. Verify EGU.
CFG any (entering LRV)	LRV > max pressure in EGU	LRV>FMX	Entered pressure is greater than maximum rated pressure of transmitter. Check entry. Verify EGUs.
	LRV < min pressure in EGU	LRV<FMN	Entered pressure is less than minimum rated pressure of transmitter. Check entry. Verify EGUs.
	URV = LRV	LRV=URV	Cannot set span to 0. Check entry. Check URV. Verify EGU.
	Calculated turndown exceeds limit	BADTDWN	Span too small. Check entry. Check URV. Verify EGU.

Table 9. Configuration Error Messages (Continued)

Parameter	Condition Tested	Error Message	User Action
CFG any (changing EGU)	LRV in new EGU is too large to display	LRV>DSP	EGU must be changed if you want to edit LRV value on display.
	URV in new EGU is too large to display	URV>DSP	EGU must be changed if you want to edit URV value on display.

Table 10. Operation Error Messages

Parameter	Condition Tested	Error Message	User Action
Normal Operation	Write protection enabled	WR PROT	Displays periodically to notify user that unit is in Write Protect.
	Any non-on-line Condition	OFFLINE	Notifies user of a non-on-line condition.
	Raw input error	S# ERR	Check connections.
	Measurement error	M# ERR	Temperature and pressures must be within configured limits.
	Measurement is being overridden	OVERRIDE	Displays periodically to notify the user that an external PC or HART Communicator calibration or loop test operation is controlling one or more measurements. To return to normal operation, complete the external operation or cycle power to the transmitter.
Startup	Database OK or corrupted	INITERR	Contact our Global Client Support Center at 1-866-746-6477.
	Bad MAU identification	UNK MAU	Contact our Global Client Support Center at 1-866-746-6477.
	RTD Mode configured Off	M5=OFF	Configure ON if desired.

4. Maintenance

—  **DANGER** —

For nonintrinsically safe installations, to prevent a potential explosion in a Division 1 hazardous area, de-energize transmitters before you remove threaded housing covers. Failure to comply with this warning could result in an explosion resulting in severe injury or death.

Fault Analysis

Infrequently, the optional display may display the message **FAULT** or **RESET**. Individual, temporary display of **FAULT** or **RESET** does not indicate a problem with the transmitter. If the cycle of **FAULT** followed by **RESET** persists, contact our Global Client Support Center at 1-866-746-6477.

In rare cases, the transmitter database can become corrupted and the transmitter does not go online when powered. This can potentially occur if power to the transmitter is interrupted during a **Save** operation. The optional display continually shows an alternating display of **INITERR** and **RESET**. In this situation, contact our Global Client Support Center at 1-866-746-6477.

Parts Replacement

Parts replacement is generally limited to the electronics module assembly, housing assembly, sensor assembly, terminal block assembly, cover O-rings, and optional display. For part numbers relating to the transmitter and its options, see PL 009-018.

Replacing the Electronics Module

To replace the electronics module assembly, refer to Figure 24 and proceed as follows:

1. Turn off the transmitter power source.
2. Remove the electronics compartment cover by rotating it counterclockwise. Screw in the cover lock if applicable.
3. Remove the digital display (if applicable) as follows: grasp the two tabs on the display and rotate it about 10° in a counterclockwise direction. Pull out the display and disconnect its cable.
4. Remove the electronics module from the housing by loosening the two captive screws that secure it to the housing. Then pull the module out of the housing far enough to gain access to the cable connectors on the rear of the module.

—  **CAUTION** —

The electronics module is “one assembly” at this point and is electrically and mechanically connected to topworks with a flexible ribbon signal cable, a 2-wire power cable, and in some cases, a cable for an external zero pushbutton. Do **not** exceed the slack available in these cables when removing the assembled module.

5. Unplug all cable connectors from the rear of the electronics module and place the module on a clean surface.
6. Predetermine connector orientation, then insert the cable connectors into the replacement module. Replace the module in the housing using care not to pinch the cables between the module and the housing. Tighten the two screws that secure the module to the housing.
7. Connect the cable from the digital display to the electronics module. Ensure that the O-ring is fully seated in the display housing. Then, holding the digital display by the tabs at the sides of the display, insert it into the housing. Secure the display to the housing by aligning the tabs on the sides of the assembly and rotating it about 10° in a clockwise direction.
8. Reinstall the cover onto the housing by rotating it clockwise to seat the O-ring into the housing and then continue to hand tighten until the cover contacts the housing metal-to-metal. If cover locks are present, lock the cover per the procedure described in “Cover Locks” on page 16.
9. Turn on transmitter power source.

The module replacement procedure is now complete.

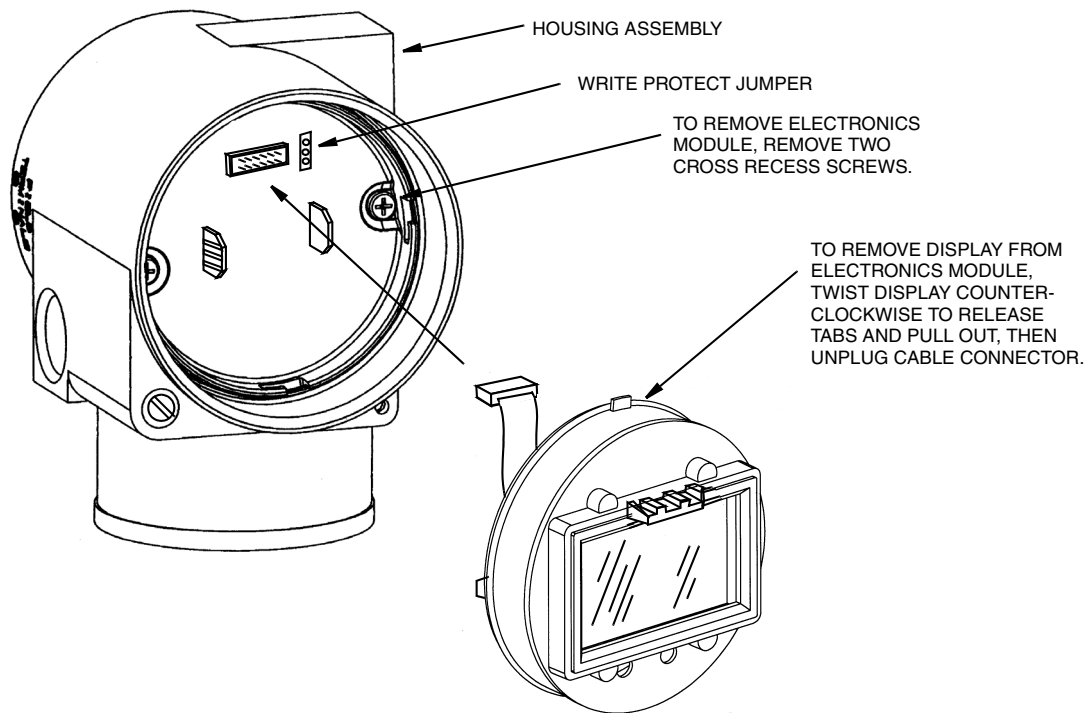

Figure 24. Replacing the Electronics Module Assembly and Display

Removing and Reinstalling a Housing Assembly

To remove and reinstall a housing assembly, refer to Figure 24 and proceed as follows:

1. Remove the electronics module per Steps 1 through 5 in the previous procedure.
2. If your housing has an anti-rotation screw, remove the red lacquer from the screw recess. Turn the screw three full turns counterclockwise.
3. If your housing has a retention clip, remove the red lacquer from the screw recess. Remove the screw completely, and slide the clip off the housing. Save the clip and screw for future use,
4. Remove the housing by rotating it counterclockwise (when viewed from the top). Use caution to avoid damaging the sensor cable.
5. Inspect the sensor O-ring for damage. If the O-ring is damaged, replace it with the appropriate O-ring. (See parts list for your transmitter). Lubricate the O-ring with silicone lubricant (Foxboro Part Number 0048130 or equivalent). Verify that the O-ring is situated in the groove of the neck.

! WARNING

Failure to reuse or install the proper O-ring for a CSA labeled product violates ANSI / ISA 12.27.01.

6. Feed the sensor cable through the housing neck into the electronics compartment.
7. Screw the housing onto the sensor neck until it bottoms. Do not over tighten. Be careful not to damage the sensor cable or dislodge the neck O-ring.
8. If your housing has an anti-rotation screw, engage the screw until it touches the sensor neck and back it off 1/8th turn. It is important that the screw is not touching the sensor. Fill the screw recess with red lacquer (Foxboro Part Number X0180GS or equivalent). The housing can then be rotated up to one full turn counterclockwise for optimum access.
9. If your housing has a retention clip, insert the clip over the boss in the housing neck so that the hole in the clip is aligned with the hole in the boss. Install the screw but do not tighten. Rotate the housing up to one full turn counterclockwise for optimum access. Tighten the retention clip screw and fill the screw recess with red lacquer (Foxboro Part Number X0180GS or equivalent). The housing can still be rotated for optimum access.
10. Reinstall the electronics module per Steps 6 through 9 in the previous procedure.

Replacing the Sensor Assembly

To replace the sensor assembly, refer to Figure 25 and proceed as follows:

1. Remove the electronics module as described above.
2. Remove the housing as described above.
3. Remove the process covers from sensor by removing two hex head bolts.
4. Replace gaskets in process covers.

5. Install process covers and housing on new sensor. Torque cover bolts to 100 N·m (75 lb·ft) in several even increments. Torque values are 68 N·m (50 lb·ft) when 316 ss bolts are specified; 75 N·m (55 lb·ft) when B7M bolts are specified.
6. Reinstall electronics module.
7. Pressure test the sensor and process cover assembly by applying a hydrostatic pressure of 150% of the maximum static pressure rating (see page 5) to both sides of the process cover/sensor assembly simultaneously through the process connections. Hold pressure for one minute. There should be no leakage of the test fluid through the gaskets. If leakage occurs, retighten the cover bolts per Step 5 (or replace the gaskets) and retest.

! CAUTION Perform hydrostatic test with a liquid and follow proper hydrostatic test procedures.

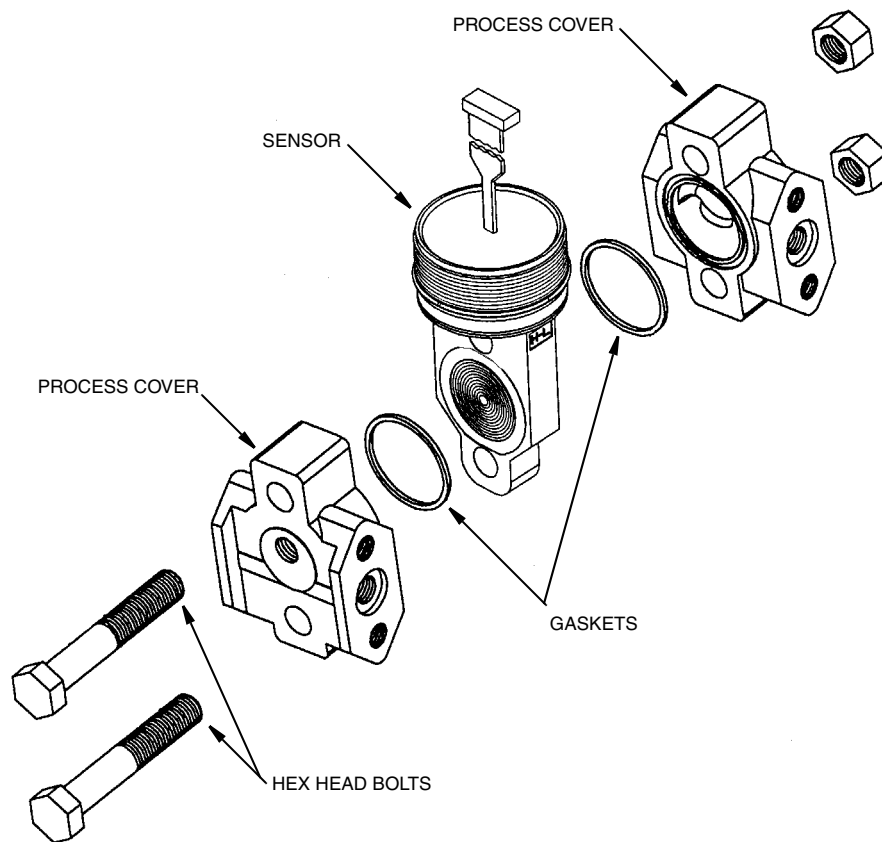

Figure 25. Replacing the Sensor Assembly

Replacing the Terminal Block Assembly

1. Turn off the transmitter power source.
2. Remove the Field Terminals compartment cover by rotating it counterclockwise. Screw in the cover lock if applicable.
3. Remove the four socket head screws securing the terminal block.
4. Disconnect the loop wiring and RTD connectors from the terminal block.
5. Remove the terminal block and the gasket under it.
6. Reconnect the loop wiring and RTD connectors to the new terminal block.
7. Install the new terminal block and new gasket and reinstall the four screws to 0.67 N·m (6 in·lb) in several even increments.
8. Reinstall the cover onto the housing by rotating it clockwise to seat the O-ring into the housing and then continue to hand tighten until the cover contacts the housing metal-to-metal. If cover locks are present, lock the cover per the procedure described in “Cover Locks” on page 16.
9. Turn on transmitter power source.

Adding the Optional Display

To add the optional display, refer to Figure 24 and proceed as follows:

1. Turn off the transmitter power source.
2. Remove the electronics compartment cover by rotating it counterclockwise. Screw in the cover lock if applicable.
3. Plug the display into the receptacle at the top of the electronics assembly.
4. Ensure that the O-ring is seated in its groove in the display housing. Then insert the display into the electronics compartment by grasping the two tabs on the display and rotating it about 10° in a clockwise direction.
5. Install the new cover (with a window) onto the housing by rotating it clockwise until the O-ring contacts the housing; then continue to hand tighten until the cover contacts the housing metal-to-metal. If cover locks are present, lock the cover per the procedure described in “Cover Locks” on page 16.
6. Turn on the transmitter power source.

Index

C

Calibration and Configuration 25
Configurable Parameters 27
Cover Locks 16

D

Display 16
Display, Adding 61

E

Electronics Module, Replacing 57
Error Messages 53

F

Fault Analysis 57
Field Terminals 17
Filling System with Seal Liquid 15
Firmware Version 2

G

General Description 1
Ground Connections 18

H

HART Communicator, Calibration and Configuration Using a 30
Housing Assembly, Removing and Reinstalling 59

I

Identification 3
Installation 13

L

Local Display, Calibration and Configuration Using the Optional 35

M

Maintenance 57
Mounting 13

P

Parts Replacement 57
 Pipe- or Surface-Mounted Transmitter 14
 Positioning Housing 15
 Product Safety Specifications 10

R

Reference Documents 2

S

Sensor Assembly, Replacing 59
 Specifications 4

T

Terminal Block Assembly, Replacing 61
 Testing the Display 53

V

Viewing the Database 53

W

Wiring 17
 Write Protection 16

ISSUE DATES

SEP 2004
 FEB 2006
 FEB 2008
 AUG 2009
 MAY 2010

Vertical lines to the right of text or illustrations indicate areas changed at last issue date.

Invensys Operations Management
 5601 Granite Parkway Suite 1000
 Plano, TX 75024
 United States of America
<http://www.iom.invensys.com>

Global Customer Support
 Inside U.S.: 1-866-746-6477
 Outside U.S.: 1-508-549-2424 or contact
 your local Invensys representative.
 Email: support@invensys.com
 Website: <http://support.ips.invensys.com>

Invensys, Foxboro, and I/A Series are trademarks of
 Invensys plc, its subsidiaries, and affiliates.
 All other brand names may be trademarks of their
 respective owners.

Copyright 2004-2010 Invensys Systems, Inc.
 All rights reserved