

**I/A Series<sup>®</sup> Pressure Transmitters**

**IDP10 Differential Pressure  
with 4 to 20 mA Output Signal**

**Installation, Operation, Calibration, Configuration, and Maintenance**



# Contents

Figures.....	v
Tables.....	vi
<b>1. Introduction .....</b>	<b>1</b>
General Description .....	1
Reference Documents .....	1
Transmitter Identification .....	2
Standard Specifications .....	3
Product Safety Specifications .....	7
ATEX and IECEx Warnings .....	8
ATEX Compliance Documents .....	8
IECEx Compliance Documents .....	9
<b>2. Installation .....</b>	<b>11</b>
Transmitter Mounting .....	11
Process Mounting .....	11
Manifold Mounted Transmitter .....	13
Transmitter Mounted on a Coplanar%o Manifold .....	14
Pipe or Surface Mounting .....	14
Standard Mounting Bracket .....	14
Universal Mounting Bracket .....	16
Venting and Draining .....	19
Traditional Structure .....	19
LP1 Low Profile Structure .....	19
LP2 Low Profile Structure .....	20
Installation of Flow Measurement Piping .....	20
Filling System with Seal Liquid .....	23
Positioning the Housing .....	24
Positioning the Display .....	24
Cover Locks .....	25
Wiring .....	26
Accessing Transmitter Field Terminals .....	26
Wiring the Transmitter to a Control Loop .....	27
Putting a Differential Pressure Transmitter Into Operation .....	30
Taking a Differential Pressure Transmitter Out of Operation .....	30
<b>3. Operation Via Local Display .....</b>	<b>33</b>
Testing the Display .....	34

Error Messages .....	36
<b>4. Calibration .....</b>	<b>37</b>
General Calibration Notes .....	37
Calibration Setup .....	39
Setup of Electronic Equipment .....	40
Field Calibration Setup .....	40
Bench Calibration Setup .....	41
Calibration Using the Local Display .....	42
Zero Adjustment Using External Zero Button .....	45
Error Messages .....	45
<b>5. Configuration.....</b>	<b>47</b>
Commentary on Configuration Structure Diagram .....	49
Reranging a Transmitter .....	50
Character Lists .....	51
Error Messages .....	51
<b>6. Maintenance.....</b>	<b>53</b>
Parts Replacement .....	53
Replacing the Terminal Block Assembly .....	53
Replacing the Electronics Module .....	53
Removing and Reinstalling the Housing Assembly .....	54
Replacing the Sensor Assembly .....	55
Rotating Process Covers for Venting .....	57
<b>Index .....</b>	<b>59</b>

# Figures

1	Transmitter Identification .....	2
2	Minimum Allowable Absolute Pressure vs. Process Temperature with Fluorinert Fill Fluid .....	5
3	Typical Mounting of an IDP Transmitter Supported by Process Piping .....	12
4	Typical Mounting of an IDP Transmitter Supported by a Bypass Manifold .....	13
5	Typical Mounting of IDP Transmitter on Coplanar Manifold .....	14
6	Pipe or Surface Mounted Transmitter Using a Standard Bracket .....	15
7	Examples of Mounting With a Standard Bracket .....	15
8	Details of a Universal Bracket .....	16
9	Mounting a Transmitter with Traditional Structure Using a Universal Bracket .....	17
10	Vertical Pipe Mounting a Transmitter with LP2 Structure Using a Universal Bracket ..	17
11	Horizontal Mounting a Transmitter with LP2 Structure Using a Universal Bracket .....	18
12	Vertical Mounting - Cavity Draining .....	19
13	Vertical Mounting - Cavity Venting .....	19
14	Horizontal Mounting - Cavity Venting .....	19
15	Vertical Mounting - Cavity Venting .....	20
16	Horizontal Mounting - Cavity Venting and Draining .....	20
17	Cavity Venting and Draining .....	20
18	Example of Horizontal Process Line Installation .....	22
19	Example of Vertical Process Line Installation .....	23
20	Housing Screw or Clip Location .....	24
21	Positioning Display .....	25
22	Cover Lock Location .....	26
23	Accessing Field Terminals .....	26
24	Identification of Field Terminals .....	27
25	Supply Voltage and Loop Load .....	28
26	Loop Wiring .....	29
27	Wiring Several Transmitters to a Common Power Supply .....	30
28	Local Display Module .....	33
29	Top Level Structure Diagram .....	34
30	Display Test Segment Patterns .....	35
31	4 to 20 mA Output Calibration Setup of Electronic Equipment .....	40
32	Field Calibration Setup .....	41
33	Bench Calibration Setup .....	42
34	Calibration Structure Diagram .....	44
35	Configuration Structure Diagram .....	48
36	Replacing the Sensor Assembly .....	56
37	Replacing the Sensor Assembly (pvdf Inserts) .....	56
38	Sensor Cavity Venting and Draining .....	57

# Tables

1	Reference Documents .....	1
2	Electrical Safety Specifications .....	8
3	Operation Error Messages .....	36
4	Calibration Menu .....	42
5	Calibration Error Messages .....	45
6	Configuration Menu .....	47
7	Alphanumeric Character List .....	51
8	Numeric Character List .....	51
9	Configuration Error Messages .....	51

# 1. Introduction

## General Description

The IDP10-A Differential Pressure Transmitters measure the difference between two pressures applied to opposite sides of a silicon strain gauge microsensor within the sensor assembly. This microsensor converts differential pressure to a change in resistance. The resistance change is then converted to a 4 to 20 mA signal proportional to differential pressure or to the square root of differential pressure. This measurement signal is transmitted to remote receivers over the same two wires that supply power to the transmitter electronics.

The transmitters are often used for measuring fluid flow across a primary device such as an orifice plate, but can also be used for other types of differential pressure measurements such as liquid level, interface level, or density measurements. For more detailed information on the principle of operation of the transmitter, refer to document TI 037-096, available from Invensys.

## Reference Documents

*Table 1. Reference Documents*

Document	Description
Dimensional Prints	
DP 020-342	Dimensional Print – PSFLT Pressure Seals
DP 020-343	Dimensional Print – PSFPS and PSFES Pressure Seals
DP 020-345	Dimensional Print – PSFAR Pressure Seals
DP 020-347	Dimensional Print – PSTAR Pressure Seals
DP 020-349	Dimensional Print – PSISR Pressure Seals
DP 020-351	Dimensional Print – PSSCR Pressure Seals
DP 020-353	Dimensional Print – PSSCT Pressure Seals
DP 020-354	Dimensional Print – PSSSR Pressure Seals
DP 020-355	Dimensional Print – PSSST Pressure Seals
DP 020-446	Dimensional Print – IDP10, IDP25, and IDP50 Differential Pressure Transmitters
DP 022-335	Dimensional Print – Model CO Compact Orifice
Parts Lists	
PL 006-172	Parts List – Model CO Compact Orifice

*Table 1. Reference Documents (Continued)*

Document	Description
PL 009-005	Parts List – IDP10 Differential Pressure Transmitter
<b>Instructions</b>	
MI 020-328	Instruction – Bubble Type Installation for Liquid Level
MI 020-329	Instruction – High Accuracy Flow Measurement
MI 020-369	Instruction – Pressure Seals
MI 022-138	Instruction – Bypass Manifolds - Installation and Maintenance
MI 022-335	Instruction – Model CO Compact Orifice
<b>Technical Information</b>	
TI 1-50a	Technical Information – Liquid Density Measurement
TI 001-051	Technical Information – Liquid Interface Measurement
TI 001-052	Technical Information – Liquid Level Measurement
TI 37-75b	Technical Information – Transmitter Material Selection Guide
TI 037-097	Technical Information – Process Sealing of I/A Series Pressure Transmitters for use in Class 1, Zone 0, 1, and 2 Hazardous Locations

## Transmitter Identification

See Figure 1 for transmitter data plate contents. For a complete explanation of the Model Number code, see the parts list. The firmware version is shown on the top line of the display when the transmitter is powered.

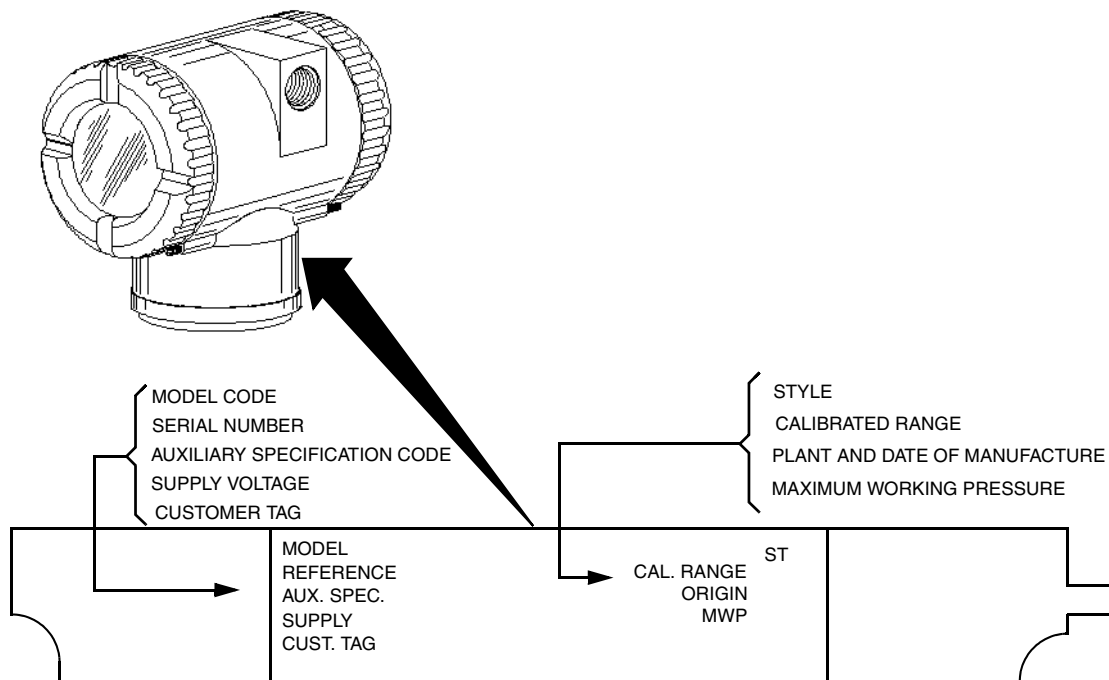

*Figure 1. Transmitter Identification*



# Standard Specifications

## Operative Limits

Influence	Operative Limits
Sensor Body Temperature <sup>(a)</sup>	-46 and +121°C (-50 and +250°F)
Silicone Fill Fluid	-29 and +121°C (-20 and +250°F)
Fluorinert Fill Fluid	-7 and +82°C (20 and 180°F)
pvc Inserts	
Electronics Temperature With LCD Display	-40 and +85°C (-40 and +185°F) -40 and +85°C (-40 and +185°F) <sup>(b)</sup>
Relative Humidity	0 and 100%
Supply Voltage <sup>(c)</sup>	11.5 and 42 V dc
Output Load	0 and 1450 ohms
Mounting Position	No Limit
Vibration	6.3 mm (0.25 in) double amplitude from 5 to 15 Hz with aluminum housing and from 5 to 9 Hz with 316 ss housing. 0 to 30 m/s (0 to 3 “g”) from 15 to 500 Hz with aluminum housing and 0 to 10 m/s (0 to 1 “g”) from 9 to 500 Hz with 316 ss housing.

(a) Refer to MI 020-369 for temperature limits with pressure seals.

(b) Display updates are slowed and readability decreased below temperatures of -20°C (-4°F).

(c) 11 V dc with optional shorting block (AS code SB-11)

## Span and Range Limits

Span Limit Code	Span Limits $\Delta P$	Range Limits $\Delta P$ <sup>(a)</sup>
A <sup>(b)</sup>	0.12 and 7.5 kPa 0.5 and 30 inH <sub>2</sub> O 12 and 750 mmH <sub>2</sub> O	-7.5 and +7.5 kPa -30 and +30 inH <sub>2</sub> O -750 and +750 mmH <sub>2</sub> O
B	0.87 and 50 kPa 3.5 and 200 inH <sub>2</sub> O 87 and 5000 mmH <sub>2</sub> O	-50 and +50 kPa -200 and +200 inH <sub>2</sub> O -5000 and +5000 mmH <sub>2</sub> O
C	7.0 and 210 kPa 28 and 840 inH <sub>2</sub> O 2.3 and 69 ftH <sub>2</sub> O	-210 and +210 kPa -840 and +840 inH <sub>2</sub> O -69 and +69 ftH <sub>2</sub> O
D	0.07 and 2.1 MPa 10 and 300 psi 23 and 690 ftH <sub>2</sub> O	-0.21 and +2.1 MPa -30 and +300 psi -69 and +690 ftH <sub>2</sub> O
E	0.7 and 21 MPa 100 and 3000 psi	-0.21 and +21 MPa -30 and +3000 psi

(a) Negative values of differential pressure indicate a higher pressure on the **low side** of the sensor. Positive values indicate a higher pressure on the **high side** of the sensor.

(b) Span Limit Code “A” not available with pressure seals.

## Maximum Static, Overage, and Proof Pressure

Transmitter Configuration (Bolting Material) <sup>(c)</sup>	Maximum Static and Overage Pressure Rating <sup>(a,e,f)</sup>		Proof Pressure Rating <sup>(b)</sup>	
	MPa	Psi	MPa	Psi
Standard (B7 steel), Option “-B2” (17-4 PH ss), Option “-D3” or “-D7”	25	3625	100	14500
Option “B1” (316 ss) or Option “-D5”	15	2175	60	8700
Option “B3” (B7M)	20	2900	70	11150
Option “-D1”	16	2320	64	9280
Option “-D2”, “-D4”, “-D6”, or “-D8” <sup>(d)</sup>	10	1500	40	6000
Option “-D9” (17-4 PH ss)	40	5800	100	14500

(a) Either side can be at higher pressure during overrange.

(b) Meets ANSI/ISA Standard S82.03-1988.

(c) -D1 = DIN Single ended process cover with M10 B7 bolting.

-D2 = DIN Double ended process cover with M10 B7 bolting

-D3 = DIN Single ended process cover with 7/16 in B7 bolting.

-D4 = DIN Double ended process cover with 7/16 in B7 bolting.

-D5 = DIN Single ended process cover with 7/16 in 316 ss bolting.

-D6 = DIN Double ended process cover with 7/16 in 316 ss bolting.

-D7 = DIN Single ended process cover with 7/16 in 17-4 ss bolting.

-D8 = DIN Double ended process cover with 7/16 in 17-4 ss bolting

-D9 = DIN Single ended process cover with 7/16 in 17-4 ss bolting.

(d) Limited to operating temperatures ranging from 0 to 60°C (32 to 140°F).

(e) When Structure Codes 78/79 are used (pvd inserts in the Hi and Lo side process covers), the maximum overrange is 2.1 MPa (300 psi) and temperature limits are -7 and +82°C (20 and 180°F).

(f) Static pressure rating of 40 MPa (5800 psi) with Option Code -Y.

---

### — NOTE —

Static pressure zero shift for all calibrated spans can be eliminated by readjusting the zero output at nominal operating static pressure.

---

### — CAUTION —

1. Exceeding the maximum overrange pressure can cause damage to the transmitter degrading its performance.
  2. The transmitter could be nonfunctional after application of the proof pressure.
- 

## Elevated Zero and Suppressed Zero

For applications requiring an elevated or suppressed zero, the maximum span and the upper and lower range limits of the transmitter can not be exceeded.

## Sensor Fill Fluid

Silicone Oil (DC 200) or Fluorinert (FC-43)

## Minimum Allowable Absolute Pressure vs. Process Temperature

With Silicone Fill Fluid: At full vacuum: Up to 121°C (250°F)  
 With Fluorinert Fill Fluid: Refer to Figure 2.

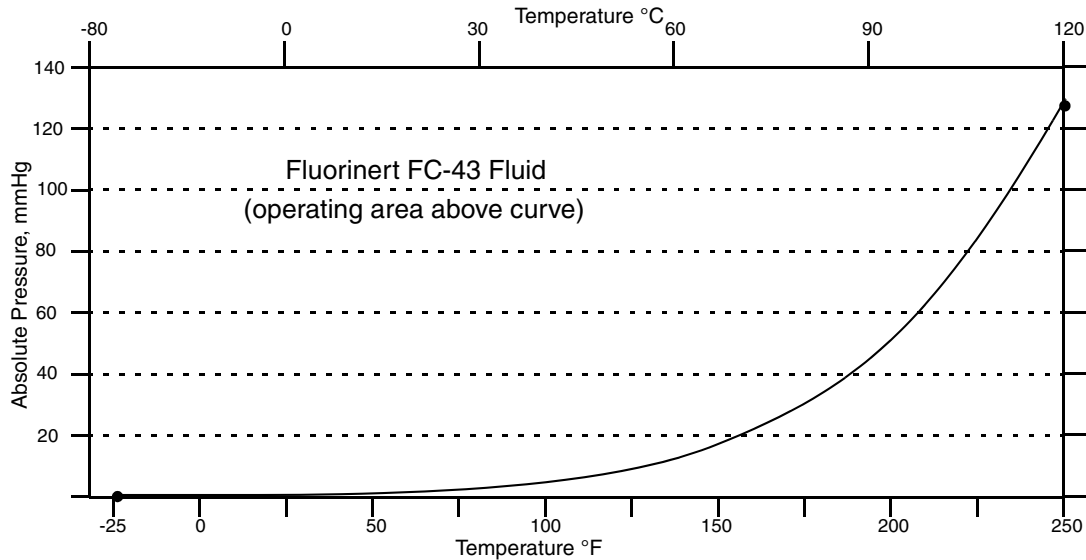

*Figure 2. Minimum Allowable Absolute Pressure vs. Process Temperature with Fluorinert Fill Fluid*

## Mounting Position

The transmitter can be mounted in any orientation. It can be supported by the process piping. It can also be mounted directly to a vertical or horizontal pipe or surface mounted using an optional mounting bracket. The housing can be rotated up to one full turn to any desired position for access to adjustments, display, or conduit connections. See “Positioning the Housing” on page 24. The display (if present) can also be rotated in the housing to any of four different positions at 90° increments. See “Positioning the Display” on page 24.

### — NOTE

Position effect zero shift for all calibrated spans can be eliminated by readjusting zero output after installation.

## Approximate Mass

Without Process Connectors	3.5 kg (7.8 lb)
With Process Connectors	4.2 kg (9.2 lb)
With Optional 316 ss Housing	Add 1.1 kg (2.4 lb)
With Pressure Seals	Varies with seal used

## Process Connections

IDP10 transmitters are connected to the process via a 1/4 NPT thread or any one of a number of optional process connectors.

### **Process Wetted Materials**

Diaphragm: 316L ss, Co-Ni-Cr, Hastelloy C, Monel, gold plated 316L ss, or tantalum  
Covers and Process Connections: 316 ss, carbon steel, Hastelloy C, Monel, or pvdf inserts  
Pressure Seals: Refer to MI 020-369.

### **Process Pressure and Temperature Limits for Pressure Seals**

Refer to MI 020-369.

### **Electrical Connections**

Field wires enter through 1/2 NPT, PG 13.5, or M20 threaded entrances on either side of the electronics housing. Leads terminate under screw terminals and washers on the terminal block in the field terminal compartment. To maintain RFI/EMI, environmental, and explosionproof ratings, unused conduit connection must be plugged with metal plug (provided), inserted to five full turns.

### **Field Wiring Reversal**

Accidental reversal of field wiring will not damage the transmitter, provided the current is limited to 1 A or less by active current limiting or loop resistance. Sustained currents of 1 A will not damage the electronics module or sensor but could damage the terminal block assembly and external instruments in the loop.

### **Adjustable Damping**

The transmitter response time is normally 1.0 second or the electronically adjustable setting of 0.00 (none), 2, 4, or 8, seconds, whichever is greater, for a 90% recovery from an 80% input step as defined in ANSI/ISA S51.1.

### **Output Signal**

4 to 20 mA dc linear, or 4 to 20 mA dc square root, software selectable, locally configurable using pushbuttons on the transmitter.

### **Zero and Span Adjustments**

Adjustable at the transmitter using the local display. An optional external self-contained moisture sealed pushbutton assembly allows local resetting of zero without removing housing cover (except on model IDP10-AS).

### **Powerup Time**

Less than 2.0 seconds for output to reach the first valid measurement, then at the electronic damping rate to reach the final measured variable value.

### **Supply Current**

Power supply must be capable of providing 22 mA current. Ripple of up to 2 V pp (50/60/100/120 Hz) is tolerable, but instantaneous voltage must remain within specified range.

## Electrical Ground Connections

The transmitter is equipped with an internal ground connection within the field wiring compartment and an external ground connection at the base of the electronics housing. To minimize galvanic corrosion, place the wire lead or terminal between the captive washer and loose washer on the external ground screw. If shielded cable is used, earth (ground) the shield at the field enclosure **only**. Do **not** ground the shield at the transmitter.

## Test Points

The banana plug receptacles (designated **CAL**) can be used to check transmitter output. Measurements should be 100 to 500 mV dc for 0 to 100% transmitter output.

## HHT Terminals

As the top terminal is blocked, this transmitter does not communicate with the PC20, PC50, HART Communicator, or IFDC.

# Product Safety Specifications

---

### — **DANGER**

To prevent possible explosions and to maintain flameproof, explosionproof, and dust-ignitionproof protection, observe applicable wiring practices. Plug unused conduit opening with the provided metal pipe plug. Both plug and conduit must engage a minimum of five full threads for 1/2 NPT connections; seven full threads for M20 and PG 13.5 connections.

---

### — **WARNING**

To maintain IEC IP66 and NEMA Type 4X protection, the unused conduit opening must be plugged with the metal plug provided. Use a suitable thread sealant on both conduit connections. In addition, the threaded housing covers must be installed. Turn covers to seat the O-ring into the housing and then continue to hand tighten until the cover contacts the housing metal-to-metal.

---

### — **NOTE**

1. These transmitters have been designed to meet the electrical safety description listed in Table 2. For detailed information or status of testing laboratory approvals/certifications, contact Invensys.
  2. Wiring restrictions required to maintain electrical certification of the transmitter are provided in “Wiring” on page 26.
-

*Table 2. Electrical Safety Specifications*

Agency Certification, Types of Protection, and Area Classification	Application Conditions	Electrical Safety Design Code
ATEX flameproof: II 2 GD EEx d IIC, Zone 1.	KEMA 00ATEX2019X Temperature Class T6, T85°C, Ta = -40 to +80°C	D
CSA explosionproof for Class I, Division 1, Groups B, C, and D; dust- ignitionproof for Class II, Division 1, Groups E, F, and G; Class III, Division 1.	Maximum Ambient Temperature 85°C (185°F).	C
CSA for Class I, Division 2, Groups A, B, C, and D; Class II, Division 2, Groups F and G; Class III, Division 2.	Temperature Class T6 at 40°C (104°F) and T4A at 85°C (185°F) maximum ambient.	
CSA field device zone certified flameproof Ex d IIC. Also, All certifications of Code C above.	Maximum Ambient Temperature 85°C (185°F).	B
FM explosionproof for Class I, Division 1, Groups B, C, and D; dust-ignitionproof for Class II, Division 1, Groups E, F, and G; Class III, Division 1.	Temperature Class T6 at 80°C (176°F) and T5 at 85°C (185°F) maximum ambient.	F
FM nonincendive for Class I, Division 2, Groups A, B, C, and D; Class II, Division 2, Groups F and G; Class III, Division 2.	Temperature Class T4A at 40°C (104°F) and T4 at 85°C (185°F) maximum ambient.	
FM field device zone certified flameproof AEx d IIC. Also, all certifications of Code F above.	Temperature Class T6 at 80°C (176°F) and T5 at 85°C (185°F) maximum ambient.	G
IECEX flameproof: Ex d IIC	IECEX FMG 06.0007X, Ex d IIC T6 Ta=80°C, T5 Ta=85°C Ambient Temperature -20 to +85°C	V

## ATEX and IECEX Warnings

Do not open while circuits are alive.

## ATEX Compliance Documents

EN 50014: 1997

EN 50018: 1994

# IECEX Compliance Documents

IEC 60079-0 (Edition 4.0): 2004

IEC 60079-1 (Edition 5): 2003





## 2. Installation

---

— **! CAUTION** —

To avoid damage to the transmitter sensor, do not use any impact devices, such as an impact wrench or stamping device, on the transmitter.

---

---

— **NOTE** —

1. The transmitter should be mounted so that any moisture condensing or draining into the field wiring compartment can exit through one of the two threaded conduit connections.
  2. Use a suitable thread sealant on all connections.
- 

### Transmitter Mounting

The IDP Series differential pressure transmitter can be supported by the process piping or mounted to a vertical or horizontal pipe or surface using the optional mounting bracket. See figures below. For dimensional information, refer to DP 020-446.

---

— **NOTE** —

1. If the transmitter is not installed in the vertical position, readjust the zero output to eliminate the position zero effect.
  2. When structure codes 78/79 are used (pvd insert) with the IDP10 transmitters, the process connection must be made directly to the pvd insert in the high and low side process covers.
- 

### Process Mounting

With process mounting, the transmitter mounted to and supported by the process piping.

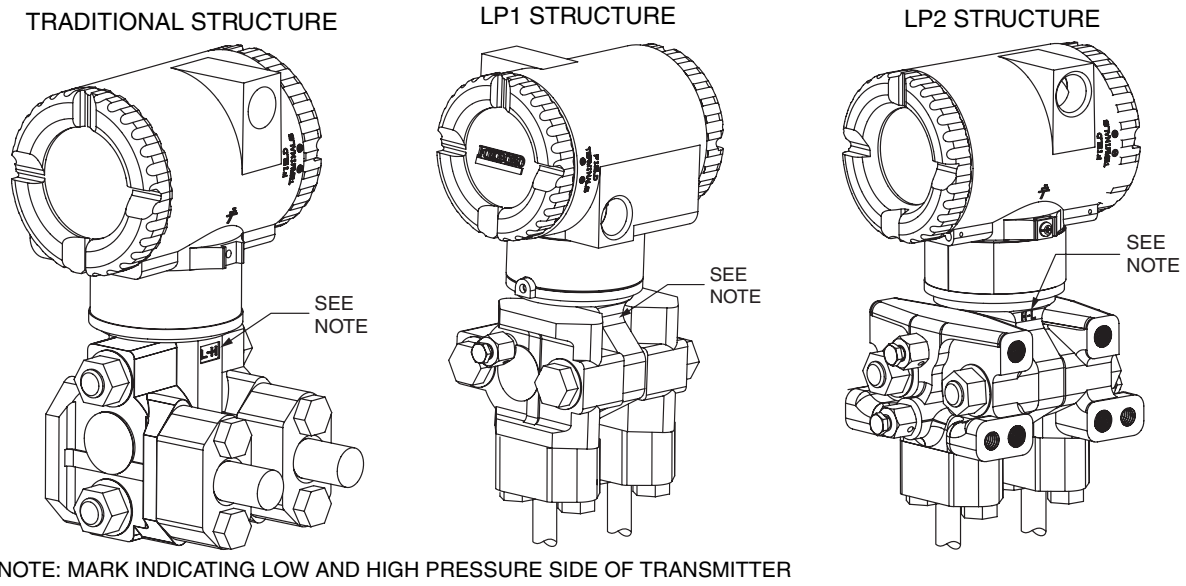

*Figure 3. Typical Mounting of an IDP Transmitter Supported by Process Piping*

## Manifold Mounted Transmitter

With manifold mounting, the transmitter is mounted to and supported by a bypass manifold. The bypass manifold can be mounted to a DN50 or 2 inch pipe with an optional mounting bracket. See MI 022-138.

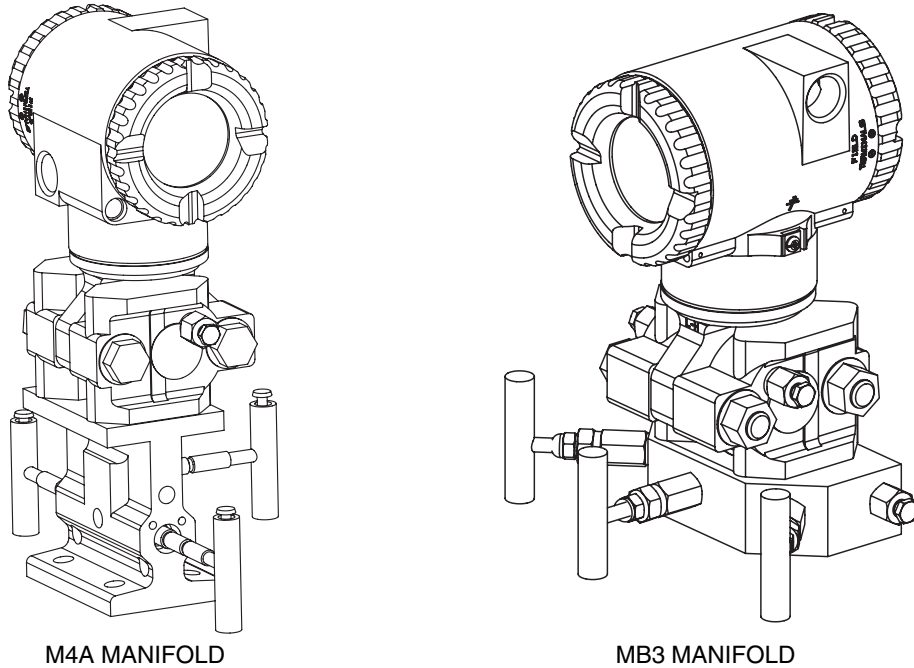

*Figure 4. Typical Mounting of an IDP Transmitter Supported by a Bypass Manifold*

## Transmitter Mounted on a Coplanar™ Manifold

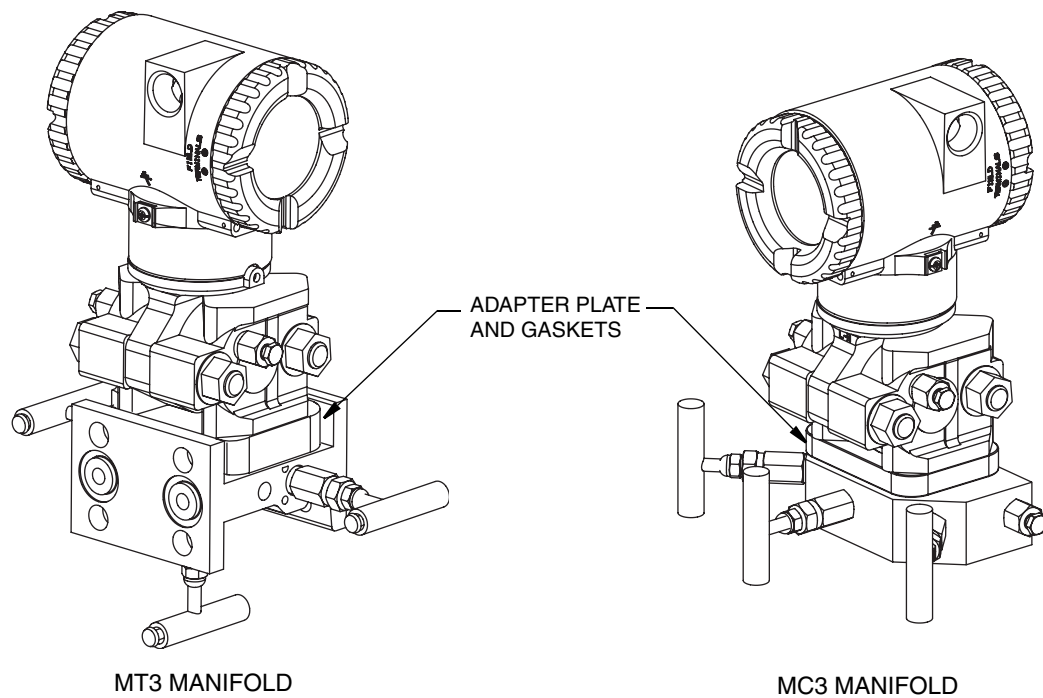

*Figure 5. Typical Mounting of IDP Transmitter on Coplanar Manifold*

## Pipe or Surface Mounting

To mount the transmitter to a pipe or surface, use the Standard Mounting Bracket Set (Model Code Option -M1 or -M2) or Universal Bracket Mounting Set (Model Code Option -M3).

### *Standard Mounting Bracket*

The transmitter (with either traditional or LP2 low-profile structures) can be mounted to a vertical or horizontal, DN 50 or 2-in pipe using a standard bracket. See Figures 6 and 7 for details of a standard bracket and examples of different mounting situations. Secure the mounting bracket to the transmitter using the four screws provided. Mount the bracket to the pipe. To mount to a horizontal pipe, turn the U-bolt 90° from the position shown. The mounting bracket can also be used for wall mounting by securing the bracket to a wall using the U-bolt mounting holes.

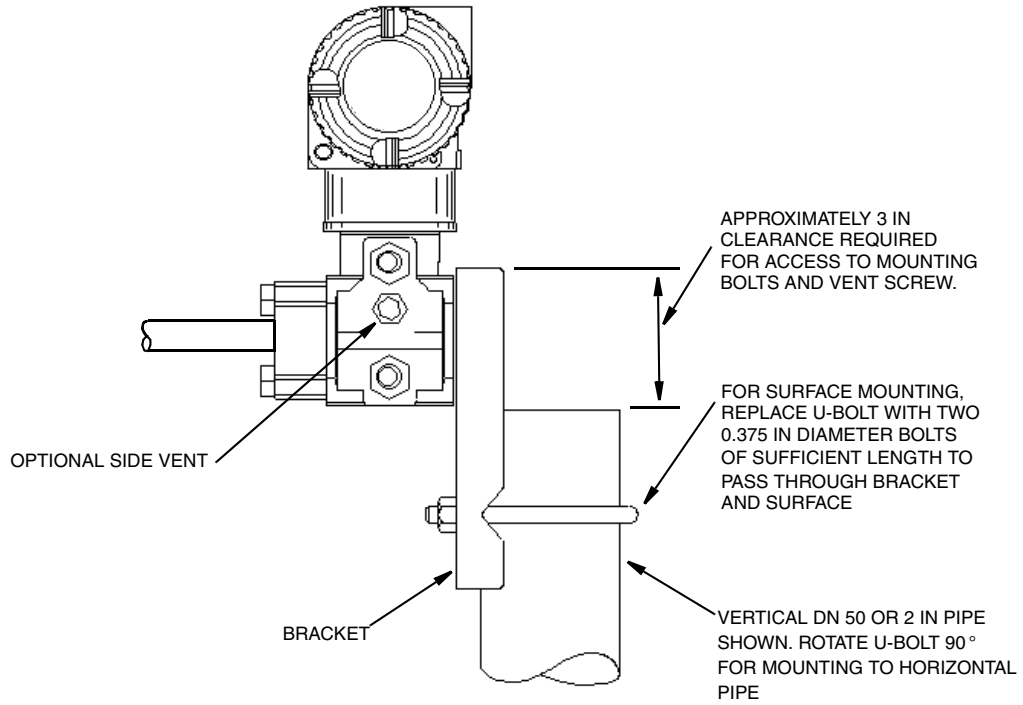

*Figure 6. Pipe or Surface Mounted Transmitter Using a Standard Bracket*

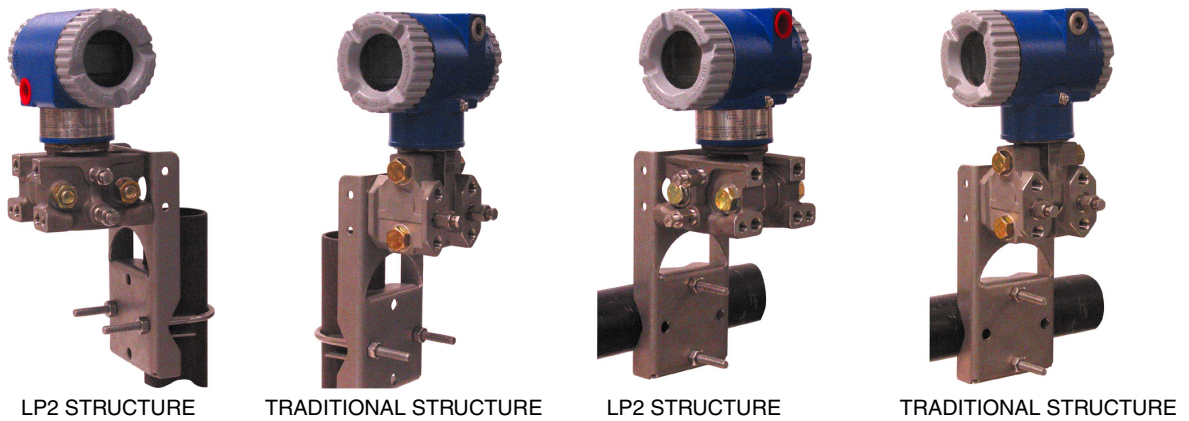

*Figure 7. Examples of Mounting With a Standard Bracket*

## Universal Mounting Bracket

The transmitter (with either traditional or LP2 low-profile structure) can be mounted in a myriad of positions to a vertical or horizontal, DN 50 or 2-in pipe using a universal bracket. See Figures 8 through 11 for details of a universal bracket and examples of different mounting situations. Secure the mounting bracket to the transmitter using the two long or four short screws provided. Mount the bracket to the pipe. The mounting bracket can also be used for wall mounting by securing the bracket to a wall using the U-bolt mounting holes.

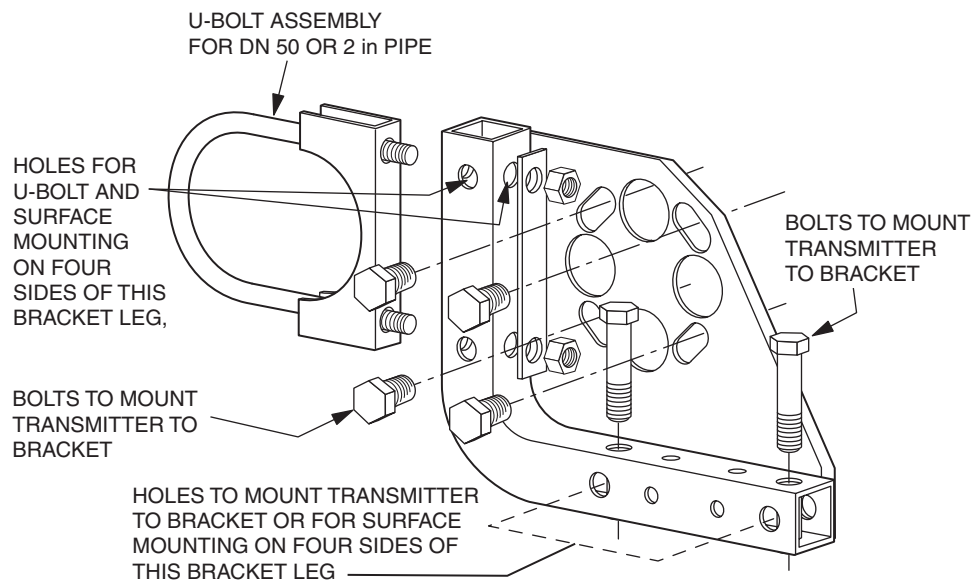

*Figure 8. Details of a Universal Bracket*

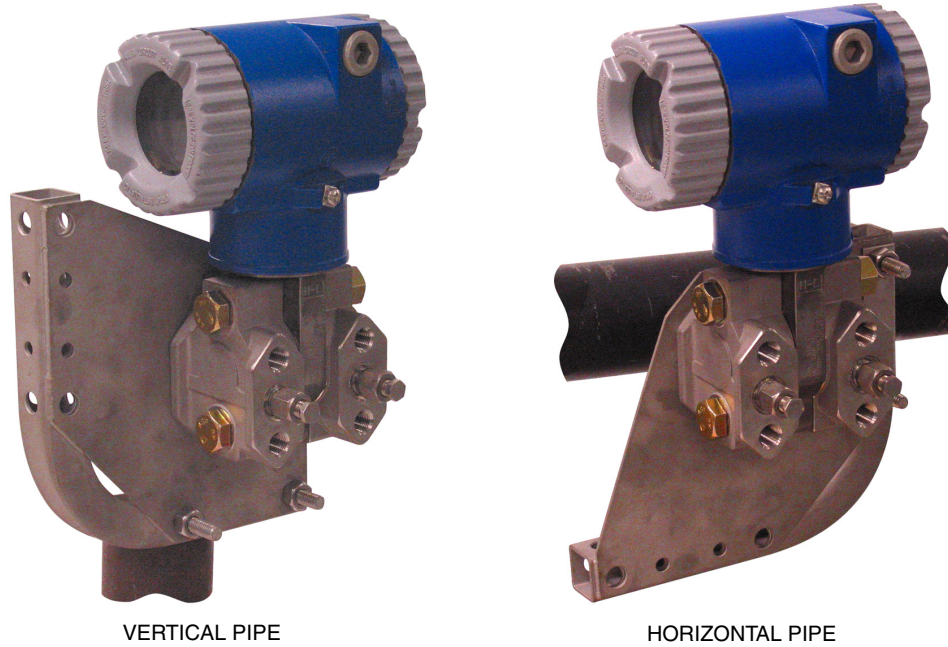

*Figure 9. Mounting a Transmitter with Traditional Structure Using a Universal Bracket*

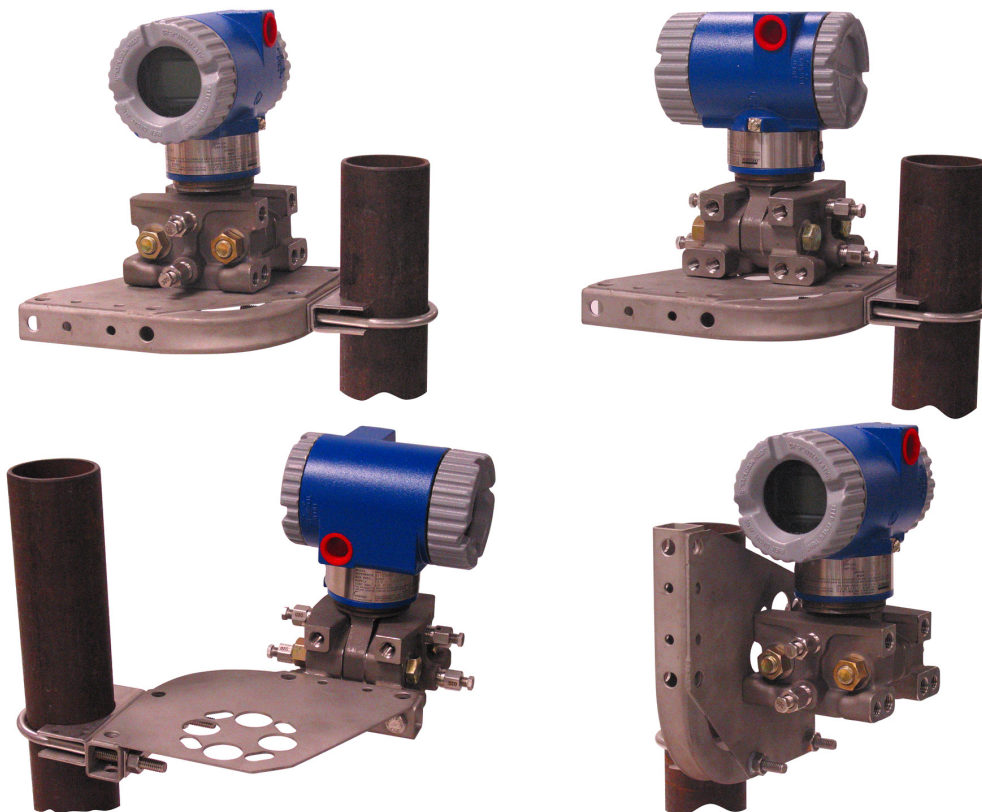

*Figure 10. Vertical Pipe Mounting a Transmitter with LP2 Structure Using a Universal Bracket*



*Figure 11. Horizontal Mounting a Transmitter with LP2 Structure Using a Universal Bracket*



# Venting and Draining

## Traditional Structure

Sensor cavity venting and draining is provided for both vertical and horizontal mounting. For vertical mounted units, draining is via a drain screw and venting is possible with side vents (Option Code -V). For horizontal mounted units, the unit is self draining and venting is via a vent screw.

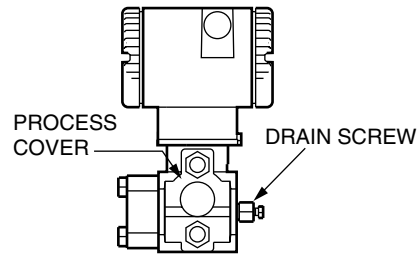

*Figure 12. Vertical Mounting - Cavity Draining*

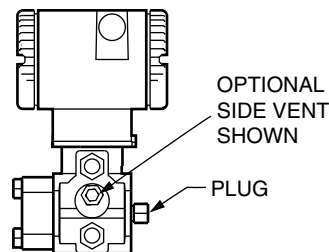

*Figure 13. Vertical Mounting - Cavity Venting*

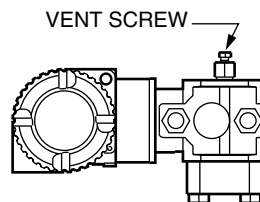
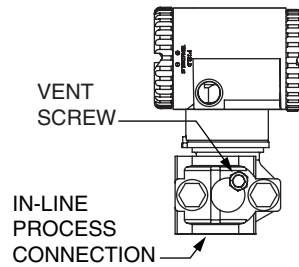

*Figure 14. Horizontal Mounting - Cavity Venting*

## LP1 Low Profile Structure

Sensor cavity venting and draining is provided for both vertical and horizontal mounting. For vertical mounted units, the transmitter is self draining and venting is via a vent screw. For horizontal mounted units, the transmitter can simply be 'turned over' (rotated 180 degrees) to orient the high and low pressure sides in the preferred locations. There is no need to unbolt the

process covers. If the transmitter is connected with a length of impulse piping, such piping should slope up to the transmitter for gas applications and down for liquid applications.



*Figure 15. Vertical Mounting - Cavity Venting*



*Figure 16. Horizontal Mounting - Cavity Venting and Draining*

## LP2 Low Profile Structure

The transmitter with LP2 low profile structure had a full-featured vent and drain design with separate vent and drain screws positioned in each cover for complete venting and draining from the sensor cavity.

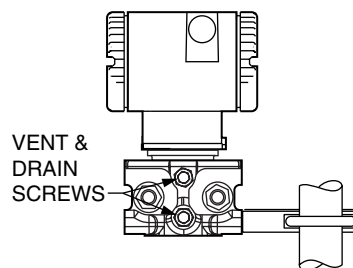

*Figure 17. Cavity Venting and Draining*

## Installation of Flow Measurement Piping

Figures 18 and 19 show typical installations with horizontal and vertical process pipes.

The transmitters are shown below the level of the pressure connections at the pipe (usual arrangement, except for gas flow without a seal liquid), and with filling tees in the lines to the transmitter (for a seal liquid).

If the process fluid being measured must not come in contact with the transmitter, the transmitter lines must be filled with a suitable seal liquid (see procedure in next section). In such a case, the transmitter must be mounted below the level of the pressure connections at the pipe. With steam flow, the lines are filled with water to protect the transmitter from the hot steam. The seal liquid (or water) is added to the lines through the filling tees. To prevent unequal heads on the transmitter, the tees must be at the same elevation and the transmitter must be mounted vertically (as shown). If a seal liquid is not required, elbows can be used in place of the tees.

Tighten drain plugs and optional vent screws to 20 N·m (15 lb·ft). Tighten the four process connector bolts to a torque of 61 N·m (45 lb·ft).

Note that the low and high pressure sides of the transmitter are identified by an L-H marking on the side of the sensor above the warning label.

With medium viscosity seal liquids and/or long transmitter lines, larger valve sizes should be used.

---

— **NOTE** —

1. With a **horizontal** line, pressure connections at the pipe should be at the side of the line. However, with gas flow without a seal liquid, connections should be at top of line.
  2. With a **vertical** line, flow should be upwards.
  3. For **liquid** or **steam** flow, the transmitter should be mounted **lower** than the pressure connections at the pipe.
  4. For **gas** flow **without** a seal liquid, the transmitter should be mounted **above** the pressure connections at the pipe; for **gas** flow **with** a seal liquid, the transmitter should be mounted **below** the pressure connections.
  5. Invensys recommends the use of snubbers in installations prone to high levels of fluid pulsations.
-

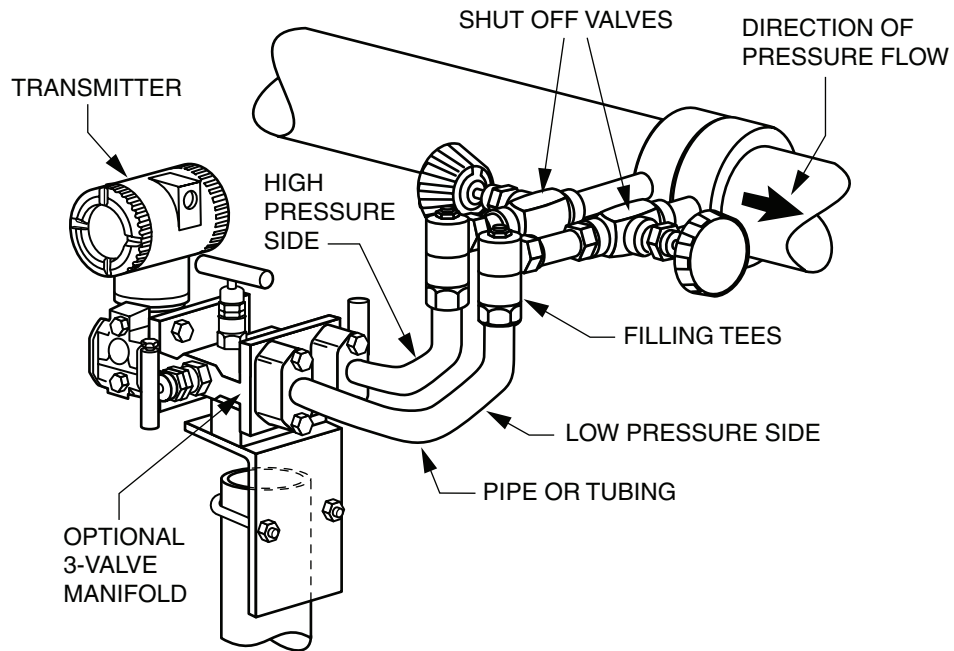

*Figure 18. Example of Horizontal Process Line Installation*

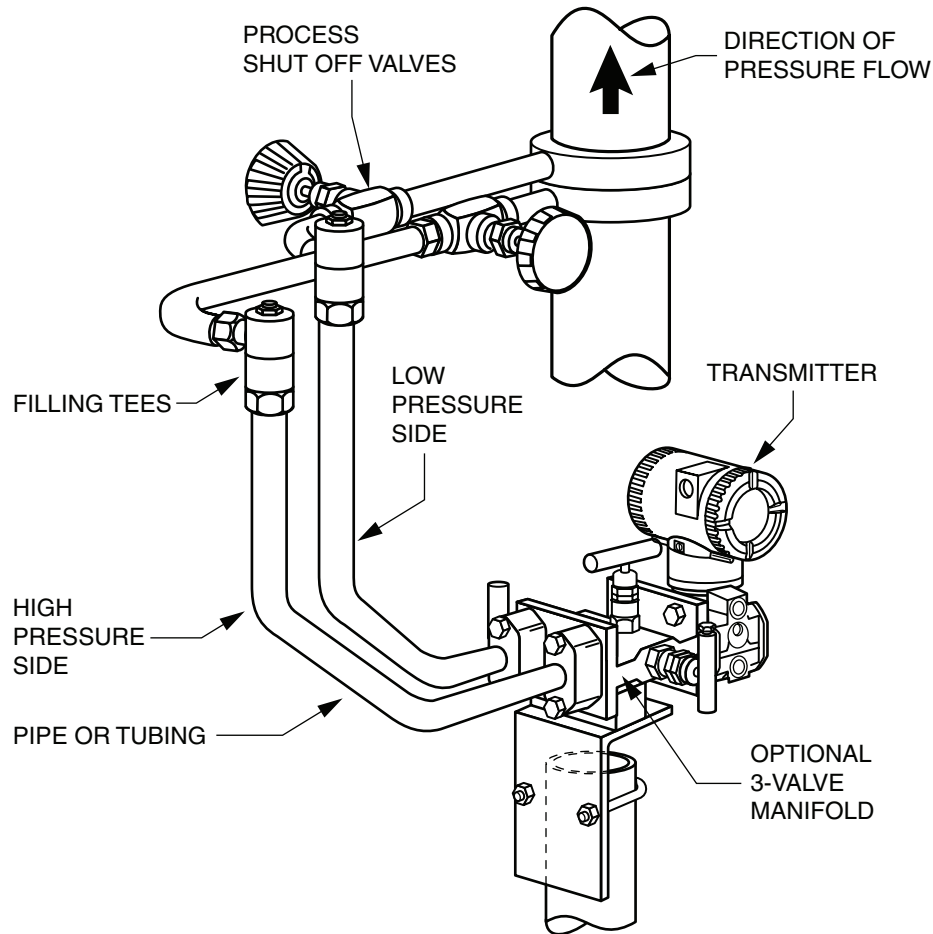

*Figure 19. Example of Vertical Process Line Installation*

## Filling System with Seal Liquid

If the process fluid being measured must not come in contact with the transmitter, the transmitter lines must be filled with a suitable seal liquid. The procedure to do this is as follows:

1. If the transmitter is in service, follow the procedure “Taking a Differential Pressure Transmitter Out of Operation” on page 30.
2. Close both process shutoff valves.
3. Open all three valves on the 3-valve manifold.
4. Partially open the vent screws on the transmitter until all air has been forced out of the transmitter body and lines. Close the vent screws.
5. Refill the tee connections. Replace the plugs and close the bypass valve. Check for leaks.
6. Follow the procedure “Putting a Differential Pressure Transmitter Into Operation” on page 30.

---

**! CAUTION**

---

To prevent loss of seal liquid and contamination of process fluid, never open both process shutoff valves and manifold shutoff valves if the bypass valve is open.

---

## Positioning the Housing

The transmitter housing (topworks) can be rotated up to one full turn in the counterclockwise direction when viewed from above for optimum access to adjustments, display, or conduit connections. Housings have either an anti-rotation screw or a retention clip that prevent the housing from being rotated beyond a safe depth of housing/sensor thread engagement.

---

**! WARNING**

---

If the electronics housing is removed for maintenance, it must be hand tightened to the bottom of the threads, but not over-tightened upon reassembly. See “Removing and Reinstalling the Housing Assembly” on page 54.

---

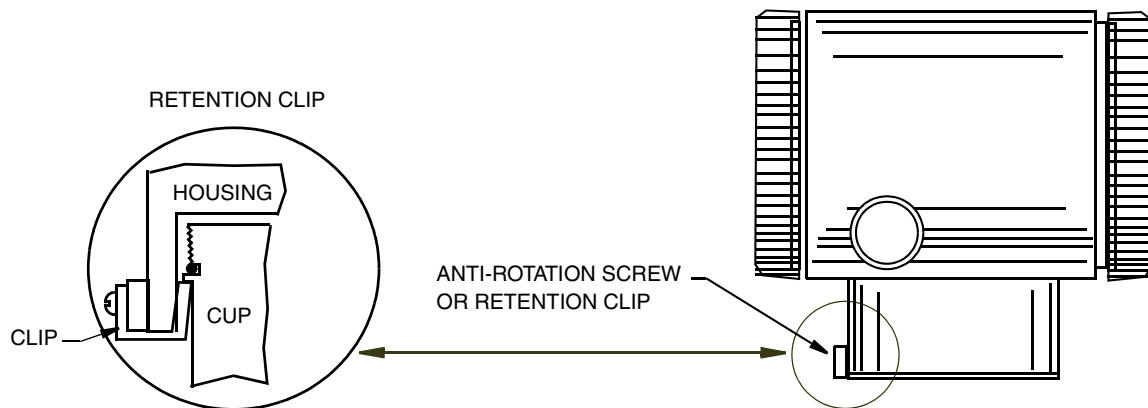

*Figure 20. Housing Screw or Clip Location*

## Positioning the Display

The display can be rotated within the housing to any of four positions at 90° increments. To do this, refer to Figure 21 and perform the following:

1. Turn off power source to the transmitter.
2. Screw in the cover lock (if present) and remove the electronics compartment cover by rotating it counterclockwise.
3. Remove the electronics module by unscrewing the two screws closest to the sides of the transmitter and pulling out the module.
4. If turning the display 180°, turn and return the module to the housing by reversing Step 3.

5. If turning the display 90° in either direction:
    - a. Remove the two (2) plastic buttons (plugs) by pushing them out from the backside of the module.
- 
- NOTE**  
Plastic buttons were not provided on some early versions of the electronics module.
- 
- b. Unscrew the two (2) screws from the module and then rethread them back into the module at 90° from their original position.
    - c. Insert the two (2) plastic buttons into the two open screw holes in the module. (To order plastic buttons for earlier versions of the electronics modules or for replacement, see appropriate Parts List listed in “Reference Documents” on page 1).
    - d. Return the module to the housing by reversing Step 3.
  6. Reinstall the cover onto the housing by rotating it clockwise until the O-ring contacts the housing; then continue to hand tighten as much as possible (at least 1/4 turn). If cover locks are present, align the serration in the cover with the lock and unscrew it until it extends into the cover serration to prevent unwanted cover rotation.
  7. Restore power to transmitter.

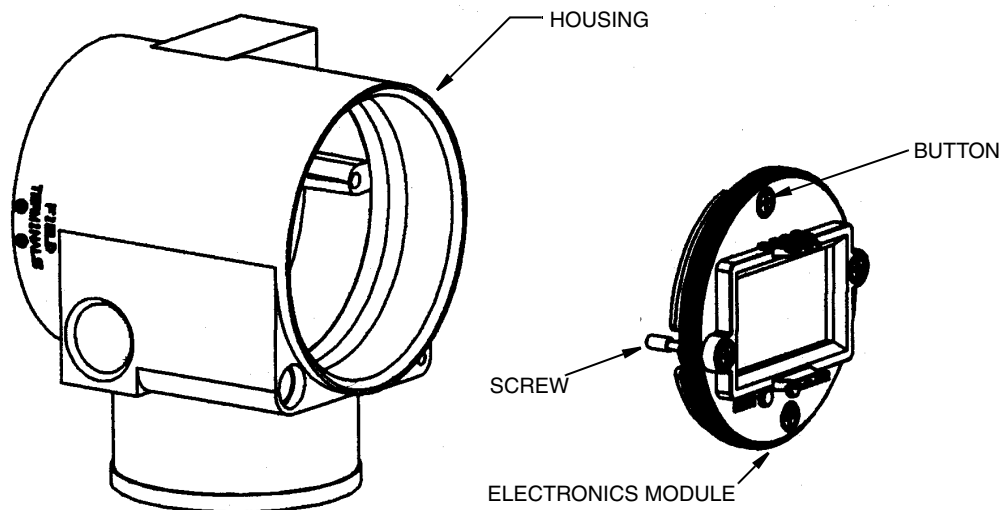

*Figure 21. Positioning Display*

## Cover Locks

Electronic housing cover locks, shown in Figure 22, are provided as standard with certain agency certifications and as part of the Custody Transfer Lock and Seal option. To lock the covers, unscrew the locking pin until approximately 6 mm (0.25 in) shows, lining up the hole in the pin with the hole in the housing. Insert the seal wire through the two holes, slide the seal onto the wire ends and crimp the seal.

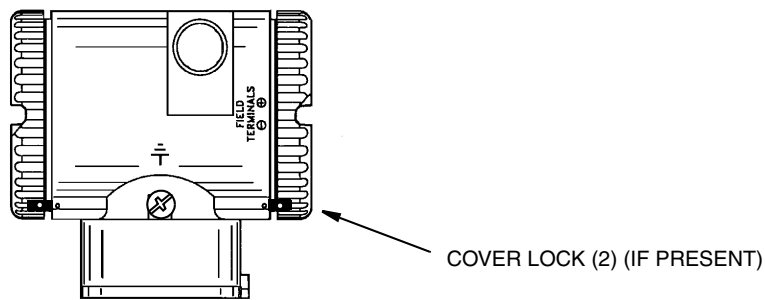

Figure 22. Cover Lock Location

## Wiring

The installation and wiring of your transmitter must conform to local code requirements.

### — **! WARNING** —

ATEX requires that when the equipment is intended to be used in an explosive atmosphere caused by the presence of combustible dust, cable entry devices and blanking elements shall provide a degree of ingress protection of at least IP6X. They shall be suitable for the conditions of use and correctly installed.

### — **NOTE** —

Invensys recommends the use of transient/surge protection in installations prone to high levels of electrical transients and surges.

## Accessing Transmitter Field Terminals

For access to the field terminals, thread the cover lock (if present) into the housing to clear the threaded cover and remove the cover from the field terminals compartment as shown in Figure 23. Note that the embossed letters **FIELD TERMINALS** identify the proper compartment.

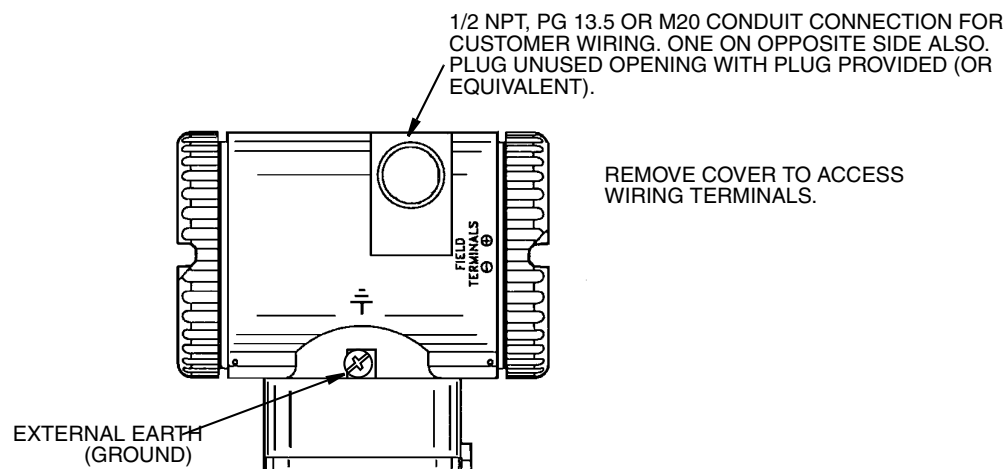

Figure 23. Accessing Field Terminals



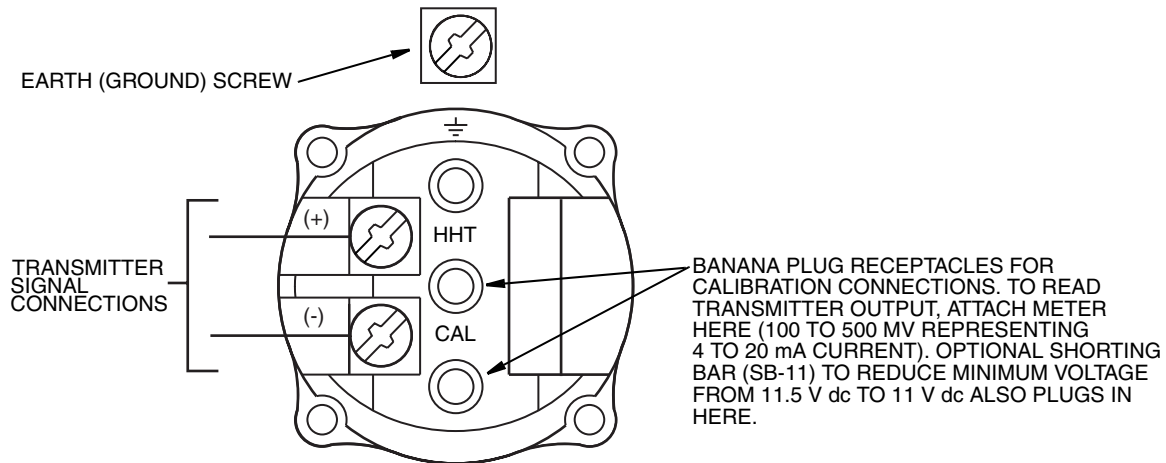

Figure 24. Identification of Field Terminals

## Wiring the Transmitter to a Control Loop

When wiring a transmitter with 4 to 20 mA output signal, the supply voltage and loop load must be within specified limits. The supply output load vs. voltage relationship is:

$R_{MAX} = 47.5 (V - 11.5)$  and is shown in Figure 25.

---

— **NOTE** —

The relationship when the optional shorting bar is used is:

$R_{MAX} = 46.8 (V - 11)$ .

---

Any combination of supply voltage and loop load resistance in the shaded area can be used. To determine the loop load resistance (transmitter output load), add the series resistance of each component in the loop, excluding the transmitter. The power supply must be capable of supplying 22 mA of loop current.

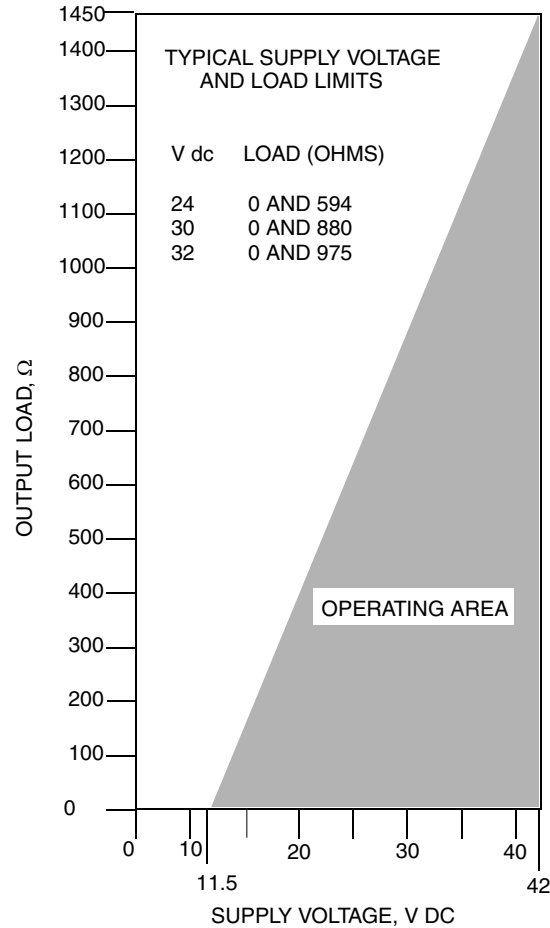

Figure 25. Supply Voltage and Loop Load

### Examples:

1. For a loop load resistance of 880  $\Omega$ , the supply voltage can be any value from 30 to 42 V dc.
2. For a supply voltage of 24 V dc, the loop load resistance can be any value from zero to 594  $\Omega$ .

To wire one or more transmitters to a power supply, proceed with the following steps.

1. Screw in cover lock (if present) and remove the field terminals compartment cover by rotating it counterclockwise.
2. Run signal wires (0.50 mm<sup>2</sup> or 20 AWG, typical) through one of the transmitter conduit connections. Use twisted single pair to protect the 4 to 20 mA output from electrical noise. Screened (shielded) cable may be required in some locations.

---

### — NOTE —

Do not run transmitter wires in same conduit as mains (ac power) wires.

---

3. If shielded cable is used, earth (ground) the shield at the power supply **only**. Do not ground the shield at the transmitter. Cut and/or tape the shield so it cannot contact the metal housing.

4. Plug unused conduit connection with the 1/2 NPT, PG 13.5 or M20 metal plug provided (or equivalent). To maintain specified explosionproof and dust-ignitionproof protection, plug must engage a **minimum** of five full threads. Thread sealant is recommended.
5. Connect an earth (ground) wire to the earth terminal in accordance with local practice.

— **! CAUTION** —

If the signal circuit must be earthed (grounded), it is preferable to do so at the negative terminal of the dc power supply. To avoid errors resulting from earth loops or the possibility of short-circuiting groups of instruments in a loop, there should be only one earth in a loop.

6. Connect the power supply and receiver loop wires to the “+” and “–” terminal connections.
7. Connect receivers (such as controllers, recorders, indicators) in series with a power supply and transmitter as shown in Figure 26.
8. Reinstall the cover onto the housing by rotating it clockwise to seat the O-ring into the housing and then continue to hand tighten until the cover contacts the housing metal-to-metal. If cover locks are present, lock the cover per the procedure described in “Cover Locks” on page 25.
9. If wiring additional transmitters to the same power supply, repeat Steps 1 through 8 for each additional transmitter. The setup with multiple transmitters connected to a single power supply is shown in Figure 27.

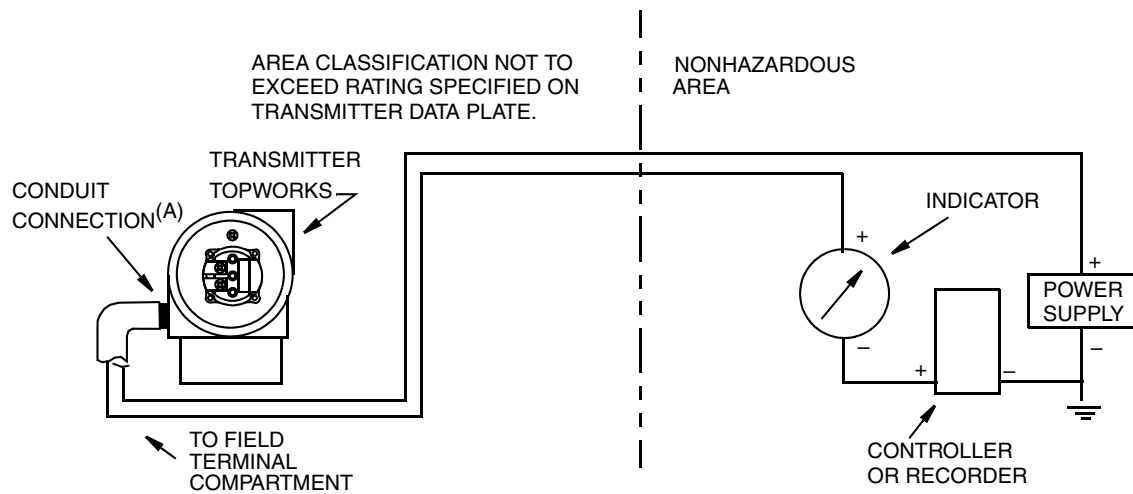

(A) RUN CONDUIT DOWN TO AVOID MOISTURE BUILDUP IN TERMINALS COMPARTMENT.

*Figure 26. Loop Wiring*

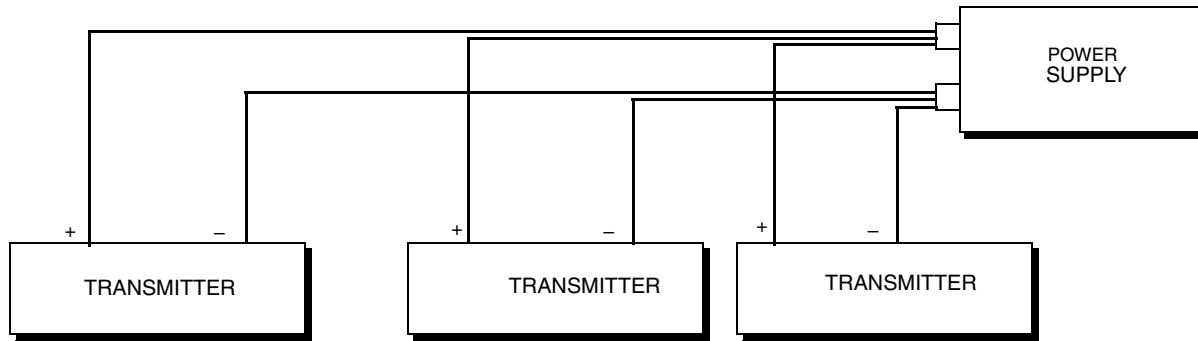

*Figure 27. Wiring Several Transmitters to a Common Power Supply*

## Putting a Differential Pressure Transmitter Into Operation

The following procedure explains how to sequence the valves in your flow measurement piping or optional bypass manifold to ensure that your transmitter is not overranged and that seal liquid is not lost. Refer to Figures 18 and 19.

---

**— NOTE**

This procedure assumes that the process shutoff valves are open.

---

1. Make sure that both upstream and downstream manifold valves are closed.
2. Make sure that the bypass valve is open.
3. Slowly open the upstream manifold valve.
4. Close the bypass valve.
5. Slowly open the downstream manifold valve.

## Taking a Differential Pressure Transmitter Out of Operation

The following procedure explains how to sequence the valves in your flow measurement piping or optional bypass manifold to ensure that your transmitter is not overranged and that seal liquid is not lost. Refer to Figures 18 and 19.

---

**— NOTE**

This procedure assumes that the process shutoff valves are open.

---

1. Close the downstream manifold valve.
2. Close the upstream manifold valve.
3. Open the bypass valve.
4. Carefully open the vent screw to release any residual pressure before disconnecting lines.

—  **WARNING** —

---

When venting pressure from the transmitter, wear suitable protective equipment to prevent possible injury from process material, temperature, or pressure.

---



### 3. Operation Via Local Display

A local display, as shown in Figure 28, has two lines of information. The upper line is a 5-digit numeric display (4-digit when a minus sign is used); the lower line is a 7-digit alphanumeric display. The display provides local indication of measurement information and a means for performing calibration and configuration, viewing the database, and testing the display via a 2-button (**Next** and **Enter**) keypad. You can access these operations by means of a multi-level menu system. Entry to the Mode Select menu is made (from normal operating mode) by pressing the **Next** button. You can exit this menu, restore your prior calibration or configuration, and return to the normal operating mode at any time by going to **Cancel** and pressing the **Enter** button.

The following items can be selected from this menu: Calibration (**CALIB**); Configuration (**CONFIG**); and Testing the display (**TST DSP**). The top level structure diagram is shown in Figure 29.

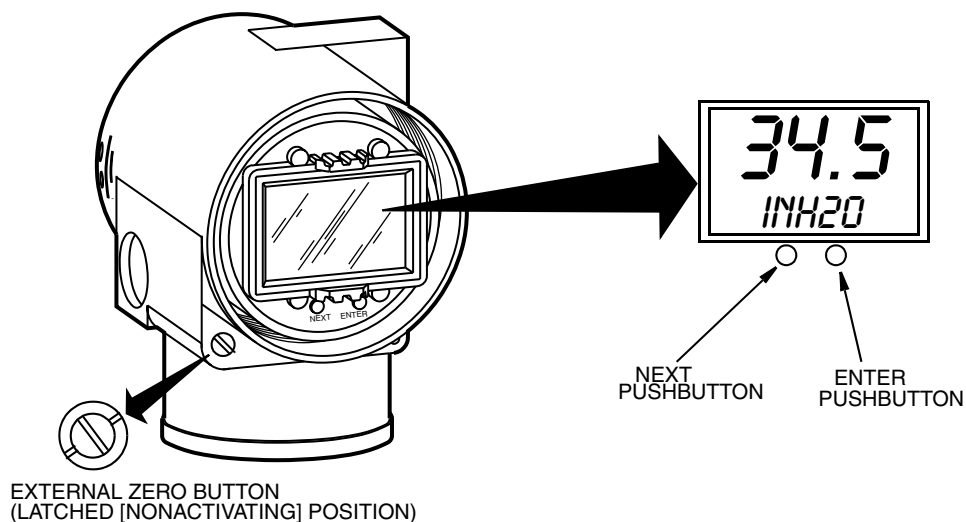

*Figure 28. Local Display Module*

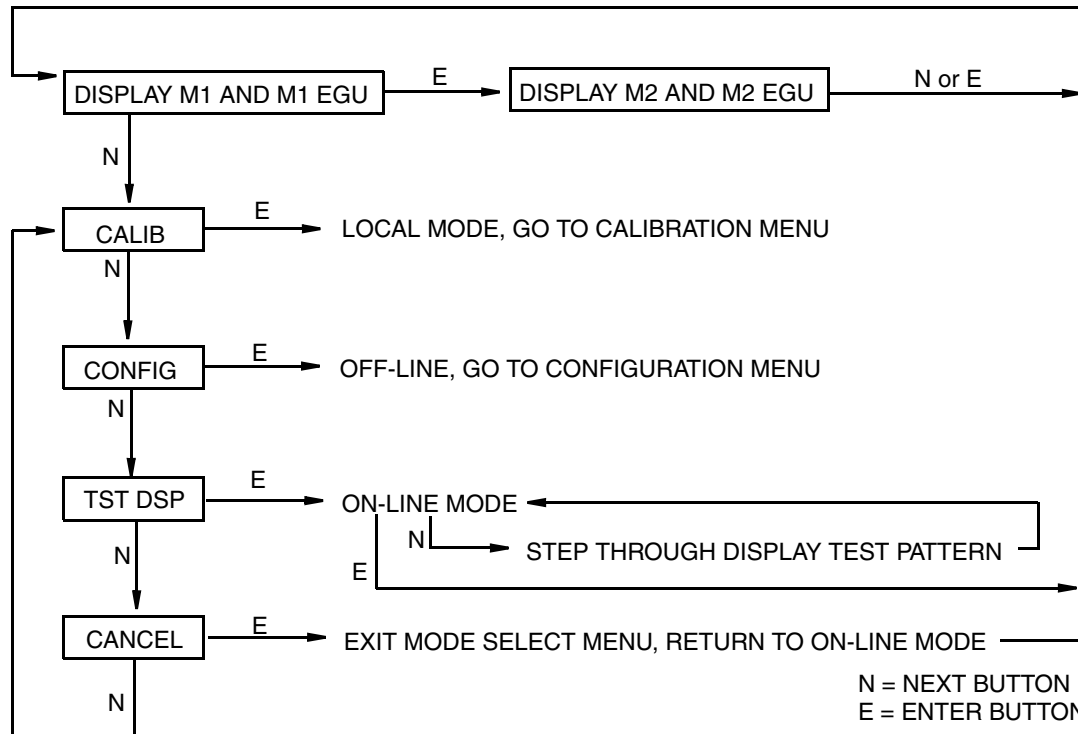

Figure 29. Top Level Structure Diagram

## Testing the Display

You can access the Test Display mode by the same multi-level menu system that was used to enter Calibration and Configuration mode. Entry to the Mode Select menu is made (from normal operating mode) by pressing the **Next** button. The display reads **CALIB**, the first item on the menu. Press the **Next** button two times to get to the third item on the menu, **TST DSP**. Acknowledge your choice of this selection by pressing the **Enter** button. The display shows the first test segment pattern. You can step through the five patterns by repeated use of the **Next** button. You can abort the test at any time by pressing the **Enter** button. The five patterns are shown in Figure 30.



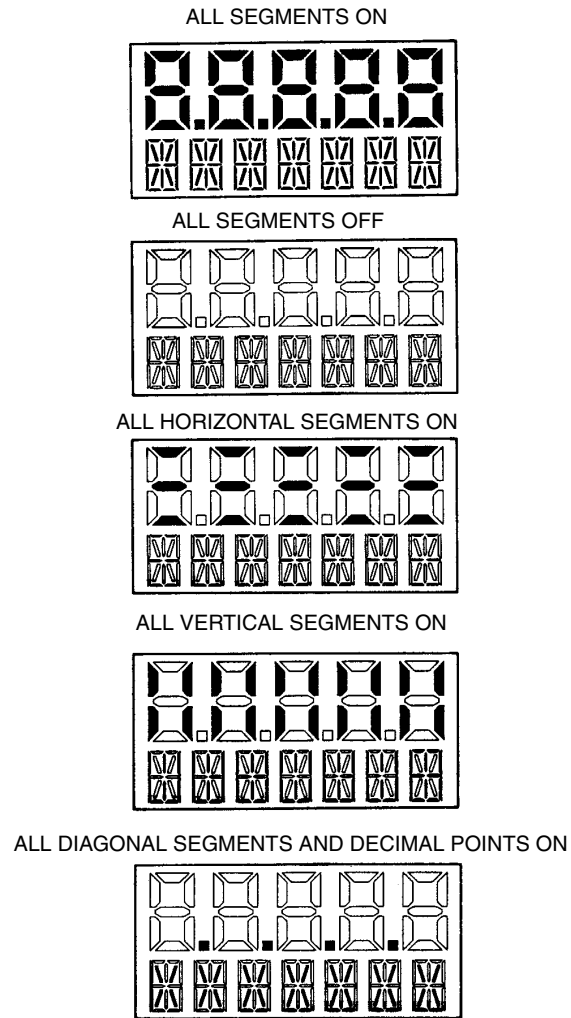

Figure 30. Display Test Segment Patterns

# Error Messages

*Table 3. Operation Error Messages*

Message	Interpretation
OVR RNG	Normalized calculation result greater than 2% above calibrated span. a. Overrange input; correct input condition. b. Bad span calibration; recalibrate span. c. Bad sensor connection; check electronics module to sensor connection. d. Defective or damaged sensor; replace sensor.
UND RNG	Normalized calculation result greater than 2% below calibrated zero. a. Underrange input; correct input condition. b. Bad zero calibration; recalibrate zero. c. Bad sensor connection; check electronics module to sensor connection. d. Defective or damaged sensor; replace sensor.
FDB ERR	CRC error detected in Factory Database on startup. a. Incorrect user database; replace sensor. b. Bad sensor connection; check electronics module to sensor. c. Defective or damaged sensor; replace sensor.
UDB ERR	CRC error detected in User Database on startup. a. Incorrect user database; reconfigure/recalibrate transmitter. b. Bad sensor connection; check electronics module to sensor. c. Defective or damaged sensor; replace sensor.
BAD IN1	Normalized raw pressure input outside of limits. a. Extreme overrange or underrange input; correct input condition. b. Bad calibration; recalibrate transmitter. c. Bad sensor connection; check electronics module to sensor. d. Defective or damaged sensor; replace sensor.
BAD IN3	Normalized raw temperature input outside of limits. a. Bad sensor connection; check electronics module to sensor. b. Defective or damaged sensor; replace sensor.
BAD KEY	Invalid keypress detected. a. Pressing <b>Enter</b> when transmitter is on-line. b. Pressing <b>Next</b> or <b>Enter</b> while <b>WAIT</b> is displayed; try again after <b>WAIT</b> message has cleared.

# 4. Calibration

---

**NOTE**

---

1. For best results in applications where high accuracy is required, rezero the transmitter output once it has stabilized at the final operating temperature.
  2. Zero shifts resulting from position effects and/or static pressure effects can be eliminated by rezeroing the transmitter output.
  3. When checking the zero reading of a transmitter operating in the square root mode, return the output to the linear mode. This eliminates an apparent instability in the output signal. Return the transmitter output to the square root mode after the zero check is complete.
  4. After calibrating transmitters operating with a 4 to 20 mA (or 1 to 5 V dc) output signal, check the underrange and overrange output values to ensure that they extend beyond 4 and 20 mA (or 1 and 5 V dc) respectively.
- 

## General Calibration Notes

1. Each transmitter is factory characterized over its full rated differential pressure range. One benefit of this process is that every transmitter can measure any applied differential pressure within its range limits regardless of the calibrated range. The applied differential pressure is measured and converted into an internal digital value. This digital value of differential pressure is always available whether the transmitter is calibrated or not. Calibration assures that the transmitter rated accuracy is achieved over the calibrated range.
2. The internal digital value of differential pressure can be displayed on the local display, and converted to a 4 to 20 mA analog output signal.
3. Each transmitter is factory calibrated to either a specified or a default calibrated range. This calibration optimizes the accuracy of the internal digital value of differential pressure over that range. If no range is specified, the default range is zero to the sensor upper range limit (URL).
4. There is an independent trim on the digital-to-analog conversion stage. This trim allows for slight adjustment of the 4 and 20 mA outputs. This compensates for any slight difference that exists between the transmitter mA output and an external reference device which is measuring the current.
  - ◆ The mA trim does not affect the calibration or the reranging of the transmitter and does not affect the internal digital value of pressure or the transmission or display of measured pressure.
  - ◆ The mA trim can be done with or without pressure applied to the transmitter.
5. The transmitter database has configurable values for both lower range value (LRV) and upper range value (URV). These stored values are used for two functions: defining the calibrated range and reranging without pressure.

a. Defining the Calibrated Range:

- ◆ When either **CAL LRV** or **CAL URV** is initiated from the pushbuttons, the transmitter expects that the differential pressure applied at the time the button is pressed is equal to the LRV or URV value respectively.
- ◆ This function trims the internal digital value of differential pressure; that is, it performs a calibration based on the application of accurate differential pressures equal to the values entered for LRV and URV in the transmitter database.
- ◆ This function also sets the 4 and 20 mA output points; that is, the 4 and 20 mA points correspond to the values of LRV and URV in the database.
- ◆ If the transmitter is configured for reverse range, the 20 and 4 mA points correspond to the LRV and URV respectively.

b. Reranging Without the Application of Pressure:

- ◆ Since the transmitter continually determines an internal digital value of the measured differential pressure from the lower range limit (LRL) to the upper range limit (URL), the 4 and 20 mA output points can be assigned to any range values (within the span and range limits) without application of pressure.
- ◆ The reranging function is accomplished by entering new database values for LRV and URV.
- ◆ Reranging does not affect the calibration of the transmitter; that is, it does not affect the optimization of the internal digital value of differential pressure over a specific calibrated range.
- ◆ If the reranged LRV and URV are not within the calibrated range, the measured values may not be as accurate as when they are within the calibrated range.

6. LCD Indicator

- ◆ The display can show any measured differential pressure in selected units regardless of the calibrated range and the values of LRV and URV (within the limits of the transmitter and display). The display can also be 0 to 100 percent.
- ◆ If the measured differential pressure is outside the range established by the LRV and URV values in the database, the display shows the measurement but also continually blinks to indicate that the measurement is out of range. The current signal is saturated at either the low or high overrange limit respectively but the display continually shows the pressure.
- ◆ Custom flow units for display, including 0 to 100 percent, are used when the transmitter is in square root mode.

7. Zeroing the Transmitter

- ◆ Zeroing does not affect the span.
- ◆ When the transmitter is zeroed to compensate for installed position effect, the transmitter may have either LRV differential pressure applied (**CAL LRV**) or zero differential pressure applied (**CAL ATO**). If the range is zero-based, either method produces the same result. However, if the range is not zero-based, it is advantageous to have both methods available.

For example, consider a differential pressure transmitter having a range of 50 to 100 psig. If it is not feasible to vent the transmitter to atmosphere for zeroing (or to bypass the high and low sides for zeroing), it may be zeroed while the LRV differential pressure of 50 psi is applied by using the **CAL LRV** function. On the other hand, if the transmitter has been installed but there is no pressure in the process line yet (or the high and low sides can be connected by a bypass valve), it can be zeroed while open to atmosphere (or bypassed) by using the **CAL AT0** function.

- a. Zeroing with LRV Pressure Applied (**CAL LRV**):
  - ◆ Before using this zeroing function, apply a differential pressure to the transmitter equal to the value of LRV stored in the transmitter database.
  - ◆ When you zero the transmitter, the internal digital value of differential pressure is trimmed to be equal to the value of LRV stored in the database and the mA output set to 4 mA.
  - ◆ If zeroing is done when the applied differential pressure is different from the LRV value in the database, the internal digital value of differential pressure is biased by the difference in the values but the output is still set at 4 mA.
  - ◆ The **CAL LRV** (and **CAL URV**) function should be used when calibrating a transmitter for a specific range with known input differential pressures applied for the LRV and URV.
- b. Zeroing with Zero Pressure Applied (**CAL AT0**):
  - ◆ Make sure that the applied differential pressure is at zero. This means venting the transmitter to atmosphere.
  - ◆ When you zero the transmitter, the internal digital value of the differential pressure is trimmed to be equal to zero and the mA output set to an appropriate value such that the mA output is a nominal 4 mA when the LRV pressure is applied later.

## Calibration Setup

The following sections show setups for field or bench calibration. Use test equipment that is at least three times as accurate as the desired accuracy of the transmitter.

---

### — NOTE —

It is not necessary to set up calibration equipment to rerange the transmitter to a different range. The transmitter can be accurately reranged by simply changing the lower range value and the upper range value, which are stored in the transmitter database.

---

## Setup of Electronic Equipment

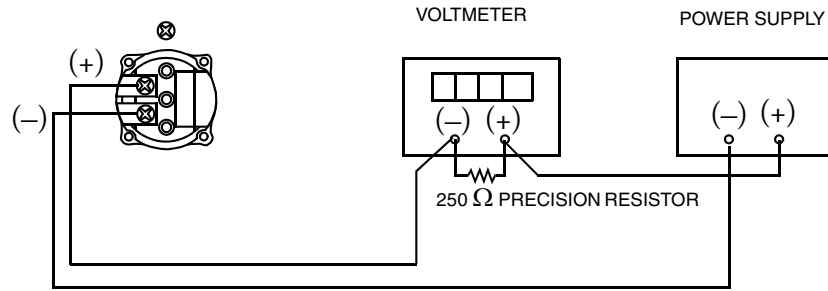

Resistor: 250  $\Omega$ ,  $\pm 0.01\%$ , 1 W minimum (Part No. E0309GY)  
 Power Supply: Refer to Figure 25  
 Digital Voltmeter: readings from 1.000 to 5.000 V dc

*Figure 31. 4 to 20 mA Output Calibration Setup of Electronic Equipment*

## Field Calibration Setup

Field calibration is performed without disconnecting the process piping. In order to do this, you must have a bypass and shutoff valves between the process and the transmitter and one of the following:

- ◆ Access to the process connections on the nonprocess side of the transmitter
- ◆ The optional vent screw in the side of the process covers.

If the transmitter is to be removed from the process for calibration, refer to “Bench Calibration Setup” on page 41.

For field calibration, an adjustable air supply and a pressure measuring device are required. For example, a dead weight tester or an adjustable clean air supply and pressure gauge can be used. The pressure source can be connected to the transmitter process connection with pipe fittings or it can be connected to the vent screw assembly using a calibration screw. The calibration screw has a Polyflo fitting and can be used for pressures up to 700 kPa (100 psi). It is available as Foxboro Part Number F0101ES.

To set up the equipment, refer to Figure 32 and use the following procedure.

1. If the transmitter is in operation, follow “Taking a Differential Pressure Transmitter Out of Operation” on page 30.

### — **! CAUTION** —

With liquid service, drain both sides of transmitter to avoid calibration errors.

2. If a calibration screw is being used, remove the vent screw and replace it with the calibration screw. Connect the pressure source to the calibration screw using 6 x 1 mm or 0.250 inch tubing. If a calibration screw is **not** being used, remove the entire vent screw assembly or drain plug (as applicable) from the high pressure side of the transmitter. Connect calibration tubing using a suitable thread sealant.
3. Close the bypass valve opened in Step 1.

## 4. Complete the setup shown in Figure 32.

**— NOTE**

For vacuum applications, connect the calibrating pressure source to the low pressure side of the transmitter.

## 5. If calibrating the output signal, also connect equipment as shown in "Setup of Electronic Equipment."

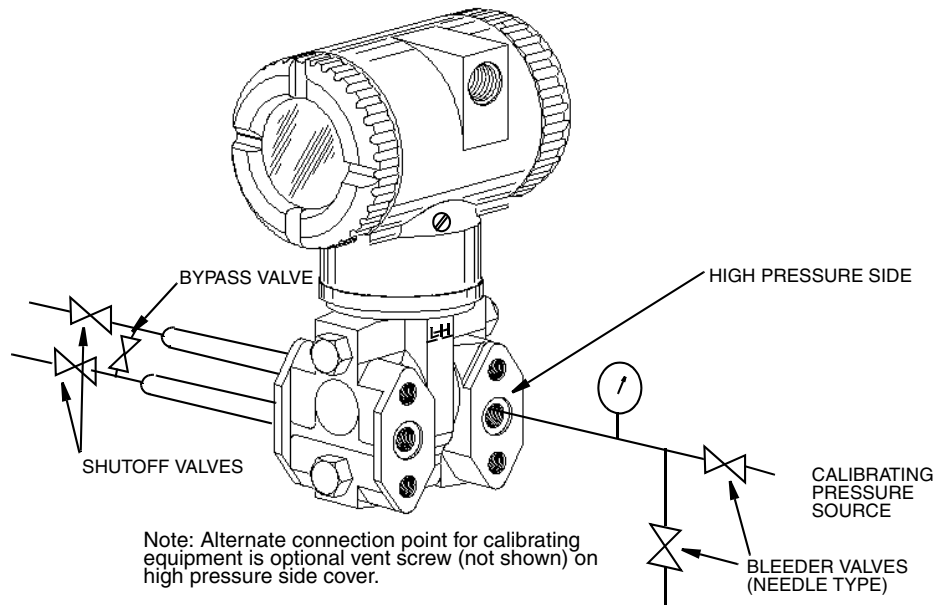

*Figure 32. Field Calibration Setup*

## Bench Calibration Setup

The bench calibration setup requires disconnecting the process piping. For calibration setup without disconnecting the process piping, refer to "Field Calibration Setup" on page 40.

The input setup is shown in Figure 33. Connect the input piping to the high pressure side of the transmitter as shown. Vent the low pressure side of the transmitter.

**— NOTE**

For vacuum applications, connect the calibrating pressure source to the low pressure side of the transmitter.

If calibrating the output signal, also connect equipment as shown in "Setup of Electronic Equipment."

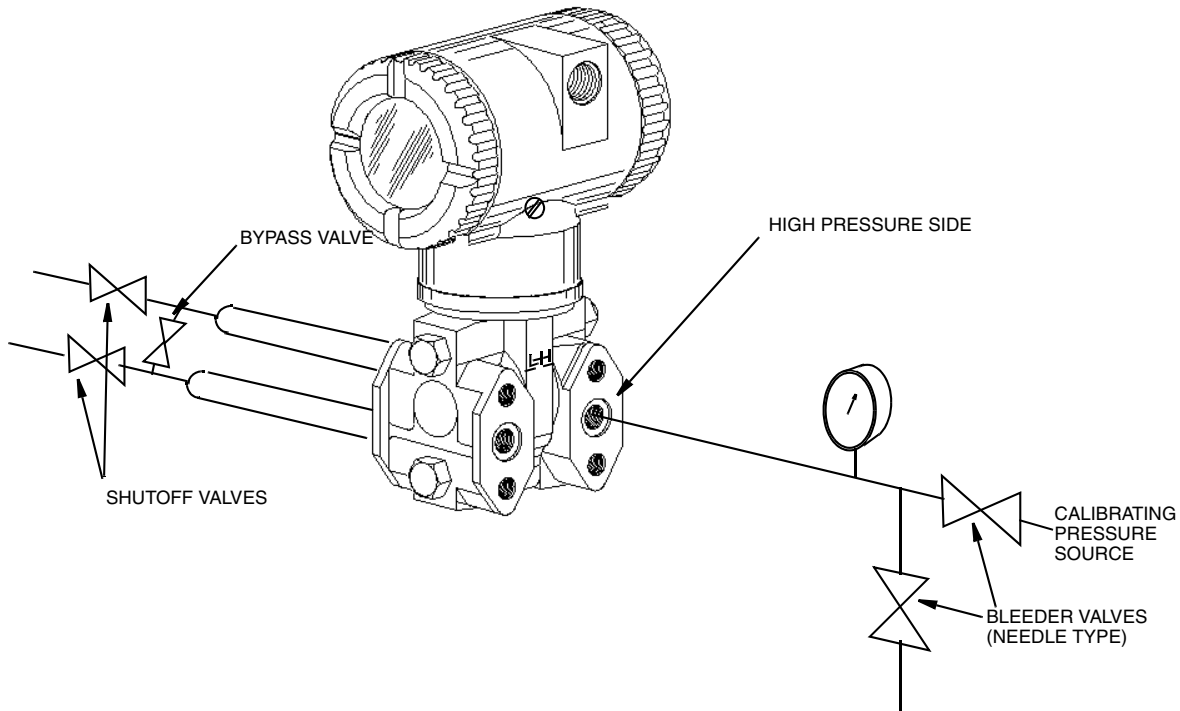

Figure 33. Bench Calibration Setup

## Calibration Using the Local Display

To access the Calibration mode (from normal operating mode), press the **Next** button. The display reads **CALIB**, the first item on the menu. Acknowledge your choice of this selection by pressing the **Enter** button. The display shows the first item in the Calibration menu.

— **NOTE** —

During calibration, a single change could affect several parameters. For this reason, if an entry is entered in error, re-examine the entire database or use the **Cancel** feature to restore the transmitter to its starting configuration and begin again.

Table 4. Calibration Menu

Item	Description
CAL AT0	Calibrate with zero pressure.
CAL LRV	Calibrate with pressure at 0% of transmitter range (LRV).
CAL URV	Calibrate with pressure at 100% of transmitter range (URV).
ADJ 4MA	Adjust nominal 4 mA output.
ADJ20MA	Adjust nominal 20 mA output.



*Table 4. Calibration Menu*

Item	Description
ADJ 4mA causes the following four submenus.	
A 4mA $\Delta\Delta$	Increase 4 mA output by large step.
A 4mA $\nabla\nabla$	Decrease 4 mA output by large step.
A 4mA $\Delta$	Increase 4 mA output by small step.
A 4mA $\nabla$	Decrease 4 mA output by small step.
ADJ 20mA causes the following four submenus.	
A 20mA $\Delta\Delta$	Increase 20 mA output by large step.
A 20mA $\nabla\nabla$	Decrease 20 mA output by large step.
A 20mA $\Delta$	Increase 20 mA output by small step.
A 20mA $\nabla$	Decrease 20 mA output by small step.

**— NOTE —**

1. It is not necessary to use the **ADJ4MA** or **ADJ20MA** menu selections unless there is a plant requirement to make the 4 and 20 mA output values exactly match readings on certain plant calibration equipment and the “zero” and “span” operations done result in a small but unacceptable difference between the transmitter mA output and the test equipment mA readout values.
2. The transmitter can be reranged without the application of pressure.

Proceed to calibrate your transmitter by using the **Next** key to select your item and the **Enter** key to specify your selection per Figure 34. At any point in the calibration you may **Cancel**, restore your prior calibration and return to the on-line mode or **Save** your new calibration.

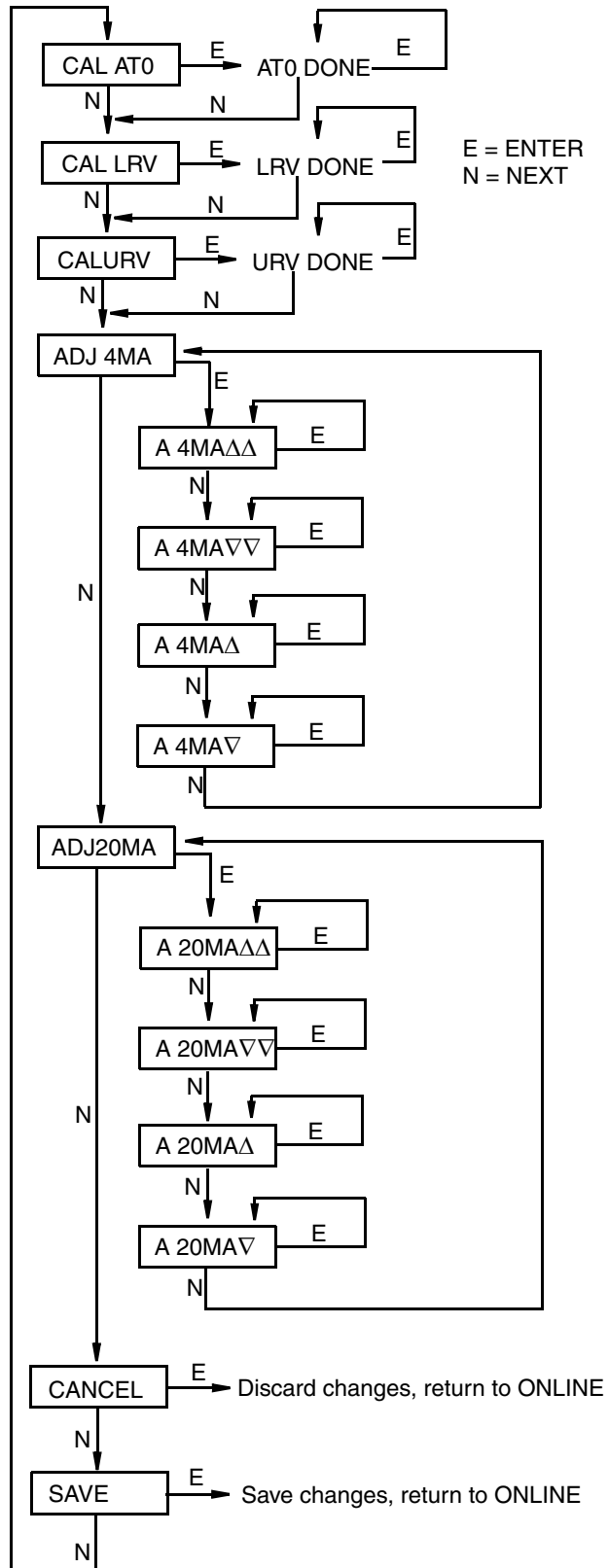

**CAL AT0:** To set or reset the zero point at zero differential pressure, apply zero differential pressure to the transmitter and, at display of **CAL AT0**, press **Enter**. This can be done whether LRV is zero or not. Completion is indicated by the display **AT0 Done**.

**CAL LRV:** To set or reset 0% of range input, apply differential pressure to the transmitter equal to the lower range value (LRV) in the transmitter database and, at display of **CAL LRV**, press **Enter**. Completion is indicated by the display **LRV Done**.

**CAL URV:** To set or reset 100% of range input, apply differential pressure to the transmitter equal to the upper range value (URV) in the transmitter database and, at display of **CAL URV**, press **Enter**. Completion is indicated by the display **URV Done**.

**ADJ4mA:** If you configured your transmitter operating mode as 4 to 20 mA, you can adjust the 4 mA output by going to **ADJ4mA** using the **Next** button and press **Enter**. This menu item is bypassed if you configured your transmitter operating mode as digital.

To increase the 4 mA output by a large (0.025 mA) step, press **Enter** at the display **A 4mAΔΔ**. To decrease it by a large step, go

Figure 34. Calibration Structure Diagram

## Zero Adjustment Using External Zero Button

An optional external zero adjustment mechanism in the electronics housing allows local “rezeroing” of the transmitter output without removing the electronics compartment cover. The mechanism is magnetically activated through the housing wall to prevent moisture from entering the enclosure. Zeroing is accomplished when the external zero button is depressed. The external zero button does a **CAL AT0** calibration (at zero differential pressure).

To use this feature:

1. Unlatch the external zero button by turning it 90° in a counterclockwise direction so that the screwdriver slot lines up with the two holes in the face of the adjacent part. Do **not** push the button in with the screwdriver while doing this.
2. Press the button with zero differential pressure applied to the transmitter or the bypass valve open and the transmitter at a nonzero static pressure.
3. The display indicates **ZEROED**. If **EX ZERO** is disabled, or the transmitter is not on-line, the display reads **Bad Key**.
4. If additional rezeroing is required, wait 20 seconds and repeat Step 2.
5. Relatch the external zero button by turning it 90° in a clockwise direction to prevent accidental pressing of the button. Do **not** push the button in with the screwdriver while doing this.

## Error Messages

*Table 5. Calibration Error Messages*

Message	Interpretation
BAD KEY	Pressing <b>External Zero</b> button with <b>EX ZERO</b> disabled or transmitter not on-line.
LOLIMIT	4 mA or 20 mA calibration adjustment has reached lower limit. a. Improper calibration setup; correct setup. b. Bad D/A converter; replace electronics module.
HILIMIT	4 mA or 20 mA calibration adjustment has reached upper limit. a. Improper calibration setup; correct setup. b. Bad D/A converter; replace electronics module.
BADZERO	Recalculation of offset during <b>CAL AT0</b> , <b>CAL LRV</b> , or <b>EX ZERO</b> resulted in out of range value. a. Applied pressure too high during operation. b. Improper calibration setup.
BADSPAN	Recalculation of slope during <b>CAL URV</b> operation resulted in out of range value. a. Applied pressure too low during <b>CAL URV</b> operation. b. Improper calibration setup.



# 5. Configuration

You can access the Configuration mode by the same multi-level menu system that was used to enter Calibration mode. Entry to the Mode Select menu is made (from normal operating mode) by pressing the **Next** button. The display reads **CALIB**, the first item on the menu. Press the **Next** button again to get to the second item on the menu, **CONFIG**. Acknowledge your choice of this selection by pressing the **Enter** button. The display shows the first item in the Configuration menu. You can then configure items shown in Table 6. The initial factory configuration is also given in this table.

---

— **NOTE** —

During configuration, a single change may affect several parameters. For this reason, if an entry is entered in error, re-examine the entire database or use the **Cancel** feature to restore the transmitter to its starting configuration and begin again.

---

*Table 6. Configuration Menu*

Item	Description	Initial Factory Configuration <sup>(a)</sup>
EX ZERO	External zero: enable or disable	Disable <sup>(b)</sup>
OUT DIR	Output direction: forward or reverse	Forward
OUTMODE	Output: linear or type of square root	Linear
OUTFAIL	Fail mode output: low or high	High
DAMPING	Damping: none, 2-, 4-, or 8-seconds	None
DISPEGU	Display measurement in EGU or in percent of span	Use EGU
EGU SEL	Engineering units for calibrated range and display: select from list if linear mode; Choose Percent or enter custom units if square root mode.	Per Sales Order for Linear; Percent for Sq Rt
EGU LRV <sup>(c)</sup>	Set Lower Range Value (LRV)	Per Sales Order
EGU URV <sup>(c)</sup>	Set Upper Range Value (URV)	Per Sales Order
DSP URV <sup>(d)</sup>	User-defined Upper Range Value for display	Per Sales Order

(a)Default settings. If optional feature “-C2” is specified, the initial factory configuration is custom per order.

(b)Not applicable to IDP10-AS and IDP10-VS.

(c)This parameter is only shown when **OUTMODE** is **LINEAR**.

(d)This parameter is only shown when **OUTMODE** is one of the square root selections.

Proceed to configure your transmitter by using the **Next** key to select your item and the **Enter** key to specify your selection per Figure 35. At any point in the configuration you may **Cancel** your changes and return to the on-line mode or **Save** your changes.

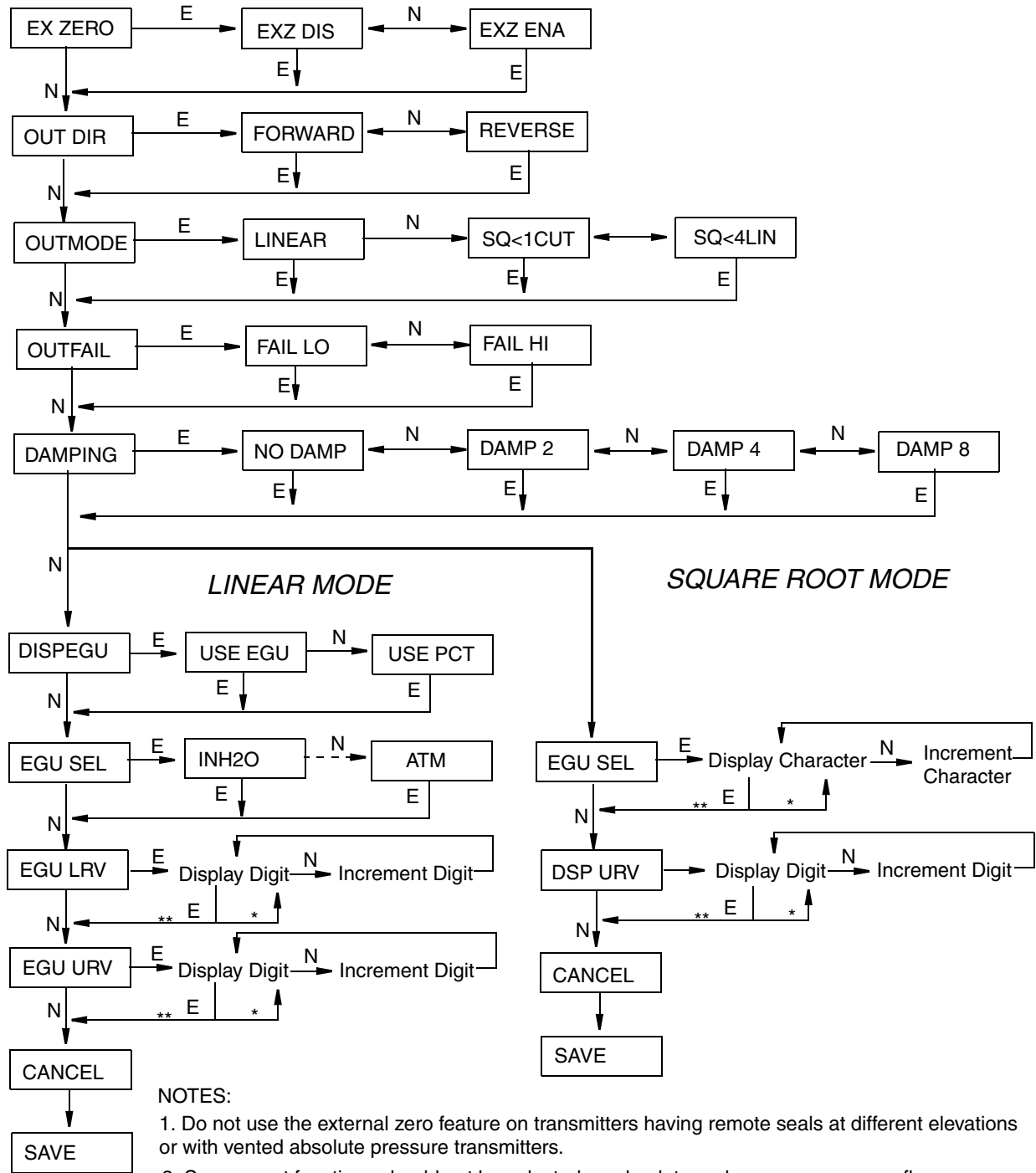

Figure 35. Configuration Structure Diagram

## Commentary on Configuration Structure Diagram

In general, use the **Next** button to select an item and the **Enter** button to specify a selection.

### EX ZERO:

The External Zero feature allows the optional external zero pushbutton to be disabled for additional security. To configure this feature, go to **EX ZERO** with the **Next** button and press **Enter**. Use the **Next** button to select **EXZ DIS** or **EXZ ENA** and press **Enter**. This feature is not applicable to the IDP10-AS and IDP10-VS Transmitters.

### OUT DIR:

To configure the Output Direction, go to **OUT DIR** with the **Next** button and press **Enter**. Use the **Next** button to select **FORWARD** (4 - 20 mA) or **REVERSE** (20 - 4 mA) and press **Enter**.

### OUTMODE:

To configure the mode of the output, go to **OUTMODE** with the **Next** button and press **Enter**. Use the **Next** button to select **LINEAR**, **SQ<1CUT** (square root with cutoff below 1% of calibrated pressure range), or **SQ<4LIN** (square root with dual slope linear below 4% of calibrated pressure range) and press **Enter**.

---

#### — NOTE —

If you wish the output and display to be in square root, it is necessary to first configure **OUTMODE** as **LINEAR** and follow the Linear Mode path to establish the pressure LRV and URV. Then go back and configure **OUTMODE** as one of the square root mode selections and follow the Square Root mode path.

---

### OUTFAIL:

The Outfail feature provides high or low output with certain malfunctions. To configure the fail mode output, go to **OUTFAIL** with the **Next** button and press **Enter**. Use the **Next** button to select **FAIL LO** or **FAIL HI** and press **Enter**.

### DAMPING:

To configure additional damping, go to **DAMPING** with the **Next** button and press **Enter**. Use the **Next** button to select **NO DAMP**, **DAMP 2**, **DAMP 4**, or **DAMP 8** and press **Enter**.

### DISPEGU:

To configure the display to present the measurement in engineering units or percent of span, go to **DISPEGU** with the **Next** button and press **Enter**. Then use the **Next** button to select **Use EGU** or **Use Pct** and press **Enter**.

### EGU SEL:

To configure engineering units for your calibrated range and display, go to **EGU SEL** with the **Next** button and press **Enter**. Depending on how **OUTMODE** is configured, the remainder of the configuration takes one of two paths.

If **OUTMODE** was configured as **LINEAR**, use the **Next** button to select one of the following units: **INH<sub>2</sub>O**, **INHG**, **FTH<sub>2</sub>O**, **MMH<sub>2</sub>O**, **MMHG**, **PSI**, **BAR**, **MBAR**, **G/CM<sup>2</sup>**,

**KG/CM<sup>2</sup>, PA, KPA, MPA, TORR, or ATM** and press **Enter**. The display advances to **EGU LRV**.

If **OUTMODE** was configured as **SQ<1CUT** or **SQ<4LIN**, you can specify any custom display unit up to seven characters in length. The display shows **Percent** with the first character flashing. Use the **Next** button to step through the library of characters to select the desired first character, then press **Enter**. Your selection is entered and the second character flashes. Repeat this procedure until you have created your new unit name. If the unit name has less than seven characters, use blanks for the remaining spaces. When you have configured the seventh space, the display advances to **DSP URV**.

#### EGU LRV:

To configure the LRV, press **Enter** at the prompt **EGU LRV**. Use the **Next** button to toggle between a space or a minus and press **Enter**. Then use the **Next** button to step through the library of numerical characters to select the desired first digit, and press **Enter**. Your selection is entered and the second digit flashes. Repeat this procedure until you have entered your last digit. Then use the **Next** button to move the decimal point to its desired location and press **Enter**.

#### EGU URV:

Similar to **EGU LRV** immediately above.

#### DSP URV:

To configure the display URV in the units specified, press **Enter** at the prompt **DSP URV**. Use the **Next** button to toggle between a space or a minus and press **Enter**. Then use the **Next** button to step through the library of numerical characters to select the desired first digit, and press **Enter**. Your selection is entered and the second digit flashes. Repeat this procedure until you have entered your last digit. Then use the next button to move the decimal point to its desired location and press **Enter**.

## Reranging a Transmitter

The transmitter can be reranged without application of pressure. To do this in linear mode, just reconfigure **EGU LRV** and **EGU URV**. To rerange the transmitter being used in Square Root mode, perform the following procedure:

1. In Configuration, set **OUTMODE** to **LINEAR**. This is a temporary state.
2. Then configure **EGU LRV** and **EGU URV**, first changing the units in **EGU SEL** if necessary.
3. Save this configuration.
4. Set **OUTMODE** back to your choice of square root mode.
5. Change **EGU SEL** and **DSP URV** if required.
6. Save this configuration.

---

#### — NOTE —

When **OUTMODE** is set in square root mode, the last saved differential pressure range set by entering **EGU LRV** and **EGU URV** in linear mode is always maintained.

---



## Character Lists

*Table 7. Alphanumeric Character List*

Characters
space
*
+
–
/
0 through 9
<
>
A through Z (uppercase)
[
\
]
Δ
- (underscore)
∇

*Table 8. Numeric Character List*

Characters
–
0 through 9

## Error Messages

*Table 9. Configuration Error Messages*

Message	Interpretation
BAD LRV	Entered value for <b>EGU LRV</b> is outside sensor limits.
BAD URV	Entered value for <b>EGU URV</b> is outside sensor limits.
BAD RNG	Recalculation of turndown during <b>EGU LRV</b> or <b>EGU URV</b> resulted in out of range value. Entered values for <b>EGU LRV</b> and/or <b>EGU URV</b> were either too close together or too far apart.
RNG>EGU	Recalculation of display value for <b>EGU LRV</b> or <b>EGU URV</b> resulted in out of range value. Selection of (linear) EGU units caused display to overflow.
LRVNOT0	Attempting mode change from <b>LINEAR</b> to <b>SQ&lt;1CUT</b> or <b>SQ&lt;4LIN</b> when <b>EGU LRV</b> is not 0.0.



# 6. Maintenance

---

—  **DANGER** —

For nonintrinsically safe installations, to prevent a potential explosion in a Division 1 hazardous area, de-energize transmitters before you remove threaded housing covers. Failure to comply with this warning could result in an explosion resulting in severe injury or death.

---

## Parts Replacement

Parts replacement is generally limited to the electronics module assembly, housing assembly, sensor assembly, terminal block assembly, cover O-rings, and optional display. For part numbers relating to the transmitter and its options, see PL 009-005.

### Replacing the Terminal Block Assembly

1. Turn off transmitter power source.
2. Remove the Field Terminals and the Electronics compartment covers by rotating them counterclockwise. Screw in cover lock if applicable.
3. Remove the digital display (if applicable) as follows: grasp the two tabs on the display and rotate it about 10° in a counterclockwise direction.
4. Remove the electronics module from the housing by loosening the two captive screws that secure it to the housing. Then pull the module out of the housing far enough to gain access to the cable connectors on the rear of the module.
5. Remove the four socket head screws securing the terminal block.
6. Disconnect the terminal block cable connector from the electronics module.
7. Remove the terminal block and the gasket under it.
8. Connect the new terminal block cable connector to the electronics module.
9. Install the new terminal block and new gasket and reinstall the four screws to 0.67 N·m (6 in·lb) in several even increments.
10. Reinstall the electronics module (and digital display if applicable).
11. Reinstall the covers onto the housing by rotating them clockwise to seat the O-ring into the housing and then continue to hand tighten until the each cover contacts the housing metal-to-metal. If cover locks are present, lock the cover per the procedure described in “Cover Locks” on page 25.
12. Turn on transmitter power source.

### Replacing the Electronics Module

To replace the electronics module assembly, proceed as follows:

1. Turn off transmitter power source.
2. Screw in cover lock (if present) and remove the threaded electronics compartment cover by rotating it counterclockwise.
3. Remove the electronics module from the housing by loosening the two captive screws that secure it to the housing. These screws are located towards the sides of the housing. Then pull the module out of the housing.

---

— **! CAUTION** —

The electronics module is “one assembly” at this point and is electrically and mechanically connected to topworks with a flexible ribbon signal cable, a 2-wire power cable, and in some cases, a cable for an optional external zero pushbutton. Do **not** exceed the slack available in these cables when removing the assembled module.

---

4. Unplug all cable connectors from the rear of the electronics module, noting the location of each cable, and place the module on a clean surface.
5. Predetermine connector orientation, then insert the cable connectors into the replacement module. Replace the module in the housing and tighten the two screws that secure it to the housing.

---

— **NOTE** —

To rotate display, see “Positioning the Display” in the Installation section.

---

6. Reinstall the cover onto the housing by rotating it clockwise to seat the O-ring into the housing and then continue to hand tighten until the cover contacts the housing metal-to-metal. If cover locks are present, lock the cover per the procedure described in “Cover Locks” on page 25.
7. Turn on transmitter power source.

The module replacement procedure is now complete.

---

— **NOTE** —

The transmitter configuration is stored in the sensor assembly. Therefore, the configuration settings are retained when replacing the electronics module. Recalibration, however, is recommended.

---

## Removing and Reinstalling the Housing Assembly

To remove and reinstall the housing assembly, proceed as follows:

1. Remove the electronics module per Steps 1 through 4 in the previous procedure.
2. If your housing has an anti-rotation screw, remove the red lacquer from the screw recess. Turn the screw three full turns counterclockwise.
3. If your housing has a retention clip, remove the red lacquer from the screw recess. Remove the screw completely, and slide the clip off the housing. Save the clip and screw for future use,
4. Remove the housing by rotating it counterclockwise (when viewed from the top). Use caution to avoid damaging the sensor cable.

5. Inspect the sensor O-ring for damage. If the O-ring is damaged, replace it with the appropriate O-ring. (See parts list for your transmitter). Lubricate the O-ring with silicone lubricant (Foxboro Part Number 0048130 or equivalent). Verify that the O-ring is situated in the groove of the neck.

— **! WARNING** —

Failure to reuse or install the proper O-ring for a CSA labeled product violates ANSI / ISA 12.27.01.

6. Feed the sensor cable through the housing neck into the electronics compartment.
7. Screw the housing onto the sensor neck until it bottoms. Do not over tighten. Be careful not to damage the sensor cable or dislodge the neck O-ring.
8. If your housing has an anti-rotation screw, engage the screw until it touches the sensor neck and back it off 1/8th turn. It is important that the screw is not touching the sensor. Fill the screw recess with red lacquer (Foxboro Part Number X0180GS or equivalent). the housing may then be rotated up to one full turn counterclockwise for optimum access.
9. If your housing has a retention clip, insert the clip over the boss in the housing neck so that the hole in the clip is aligned with the hole in the boss. Install the screw but do not tighten. Rotate the housing up to one full turn counterclockwise for optimum access. Tighten the retention clip screw and fill the screw recess with red lacquer (Foxboro Part Number X0180GS or equivalent). The housing can still be rotated for optimum access.
10. Reinstall the electronics module per Steps 5 through 7 in the previous procedure.

## Replacing the Sensor Assembly

To replace the sensor assembly, refer to Figures 36 and 37 and proceed as follows:

1. Remove the electronics module as described above.
2. Remove the housing as described above.
3. Remove the process covers from sensor by removing two hex head bolts.
4. Replace the gaskets in the process covers.
5. Install the process covers and housing on the new sensor. Torque cover bolts to 100 N·m (75 lb·ft) in several even increments. Torque values are 68 N·m (50 lb·ft) when 316 ss bolts are specified; 75 N·m (55 lb·ft) when B7M bolts are specified.
6. Reinstall electronics module.
7. Pressure test the sensor and process cover assembly by applying a hydrostatic pressure of 150% of the maximum static and overrange pressure rating to both sides of the process cover/sensor assembly simultaneously through the process connections. Hold pressure for one minute. There should be no leakage of the test fluid through the gaskets. If leakage occurs, retighten the cover bolts per Step 5 (or replace the gaskets) and retest.

**! CAUTION**  
Perform hydrostatic test with a liquid and follow proper hydrostatic test procedures.

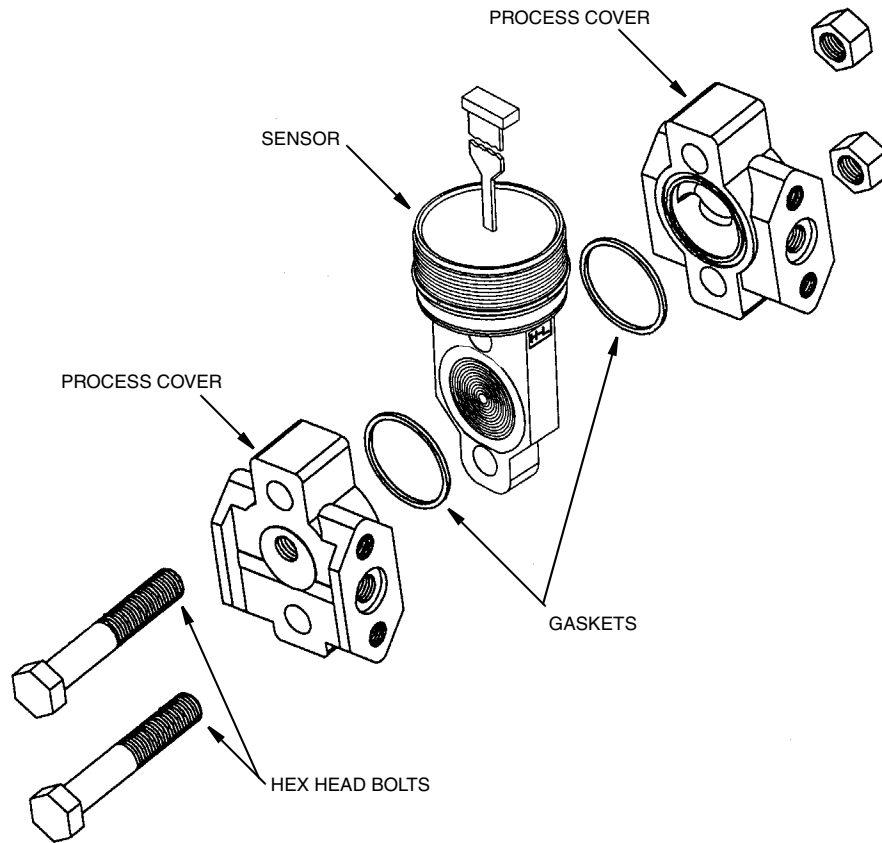

Figure 36. Replacing the Sensor Assembly

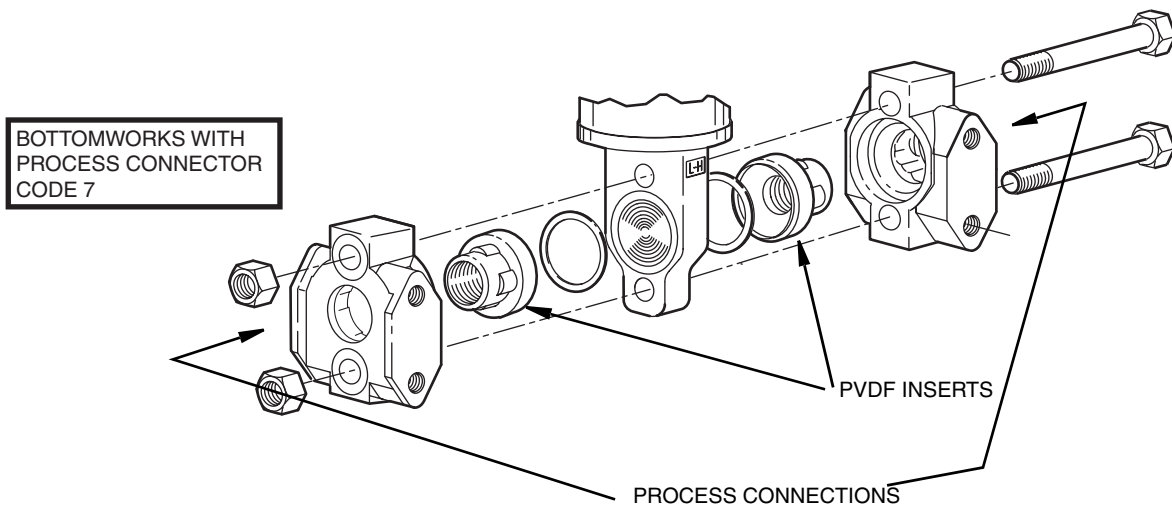
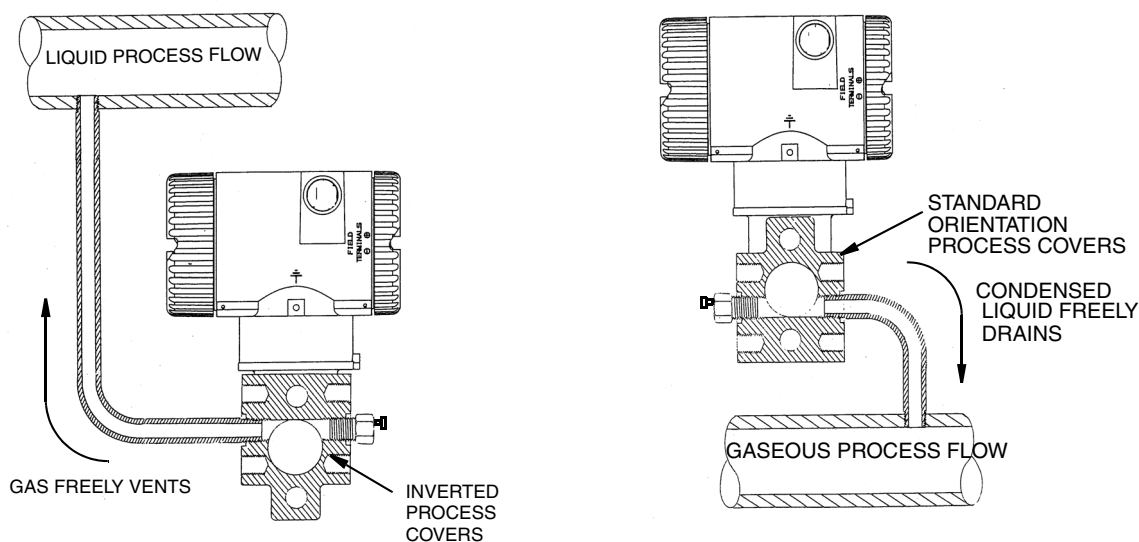

Figure 37. Replacing the Sensor Assembly (pvdf Inserts)

## Rotating Process Covers for Venting

As received, your IASPT Transmitter provides sensor cavity draining without the need for side drain connections, regardless of whether the transmitter is mounted vertically or horizontally. Sensor cavity venting is provided by mounting the transmitter horizontally or with the optional vent screw (-V). However, if you did not specify this option, you can still achieve venting (instead of draining) with vertical mounting by rotating the process covers. See Figure 38.



*Figure 38. Sensor Cavity Venting and Draining*

To rotate the process covers, refer to Figure 36 and proceed as follows:

1. Turn off the transmitter power source and remove the transmitter from the process.
2. Remove the process covers from sensor by removing two hex head bolts.
3. Replace gaskets in process covers.
4. Rotate the process covers so that the longer tab is at the bottom.
5. Reinstall process covers and bolts. Torque cover bolts to 100 N·m (75 lb·ft) in several even increments. Torque values are 68 N·m (50 lb·ft) when 316 ss bolts are specified; 75 N·m (55 lb·ft) when B7M bolts are specified.
6. Pressure test the sensor and process cover assembly by applying a hydrostatic pressure of 150% of the maximum static and overrange pressure (see “Standard Specifications” on page 3) to both sides of the process cover/sensor assembly simultaneously through the process connections. Hold pressure for one minute. There should be no leakage of the test fluid through the gaskets. If leakage occurs, retighten the cover bolts per Step 4 or replace the gaskets and retest.

**! CAUTION**  
 Perform hydrostatic test with a liquid and follow proper hydrostatic test procedures.





# ***Index***

## **C**

- Calibration 37
  - Notes 37
  - Setup 39
  - Using the Local Display 42
- Configuration 47
- Cover Locks 25

## **D**

- Display, Positioning the 24

## **E**

- Error Messages
  - Calibration 45
  - Configuration 51
  - Operation 36

## **H**

- Housing, Positioning the 24

## **I**

- Identification 2
- Installation 11

## **M**

- Maintenance 53
- Mounting 11

## **O**

- Operation 33

## **P**

- Parts Replacement 53
- Piping, Installation of Flow Measurement 20

## **R**

- Reference Documents 1

Reranging 50

**S**

Seal Liquid, Filling System with 23

Specifications

Product Safety 7

Standard 3

**W**

Wiring 26

**Z**

Zero Adjustment Using External Zero Button 45

ISSUE DATES

- DEC 2001
- OCT 2003
- APR 2004
- FEB 2005
- FEB 2006
- OCT 2007
- MAY 2010

Vertical lines to the right of text or illustrations indicate areas changed at last issue date.

Invensys Operations Management  
 5601 Granite Parkway Suite 1000  
 Plano, TX 75024  
 United States of America  
<http://www.iom.invensys.com>

Global Customer Support  
 Inside U.S.: 1-866-746-6477  
 Outside U.S.: 1-508-549-2424 or contact  
 your local Invensys representative.  
 Email: [support@invensys.com](mailto:support@invensys.com)  
 Website: <http://support.ips.invensys.com>

Invensys, Foxboro, and I/A Series are trademarks of  
 Invensys plc, its subsidiaries, and affiliates.  
 All other brand names may be trademarks of their  
 respective owners.

Copyright 2001-2010 Invensys Systems, Inc.  
 All rights reserved