

244LVP *Levelstar* Intelligent Buoyancy Transmitter for Liquid Level, Interface and Density

Vers. 6.1.x



The intelligent transmitter 244LVP *LevelStar* is designed to perform continuous measurements for liquid level, interface or density of liquids in the process of all industrial applications. The measurement is based on the proven Archimedes buoyancy principle and thus extremely robust and durable. Measuring values can be transferred analog and digital. Digital communication facilitates complete operation and configuration via PC or control system. The 244LVP measures with consistent reliability and high precision. For installations in contact with explosive atmospheres up to Zone 0, certificates are available. The 244LVP *LevelStar* combines the abundant experience of FOXBORO ECKARDT with most advanced digital technology.

FEATURES

- Communication HART (4-20 mA)
- Conventional operation with local keys
- Easy adaptation to the measuring point without calibration at the workshop
- Backdocumentation of measuring point
- Configurable safety value
- Software lock against unauthorized operation
- Simulation of analog output for loop-check
- Local display in %, mA or physical units
- Signal noise suppression by Smart Smoothing
- Continuous self-diagnostics
- Linear or customized characteristic
- Process temperature from -50 °C to $+150\text{ °C}$
- Static pressure up to PN 40
- Micro sintermetal sensor technology

CONTENTS

CHP. CONTENTS	PAGE	CHP. CONTENTS	PAGE
1 DESIGN	3	6 COMMISSIONING	9
2 METHOD OF OPERATION	3	7 DECOMMISSIONING	9
3 IDENTIFICATION Nameplates	4	8 SETTING OF TRANSMITTER Operation via local keys Menus on the LCD	9 10 10
4 MOUNTING	5	9 DIMENSIONING OF DISPLACER	16
4.1 Mounting on top of the vessel	5	10 MEASURING PRINCIPLE	18
4.2 Mounting on the side of the vessel	5	10.1 Block diagram for HART Communication	19
4.3 Transmitter mounting	6	10.2 Explanations to Block diagram	19
4.4 Displacer 204DE	7	11 SUPPLY OF TRANSMITTER	22
5 ELECTRICAL CONNECTION	8		
5.1 Signal wire connection	8		

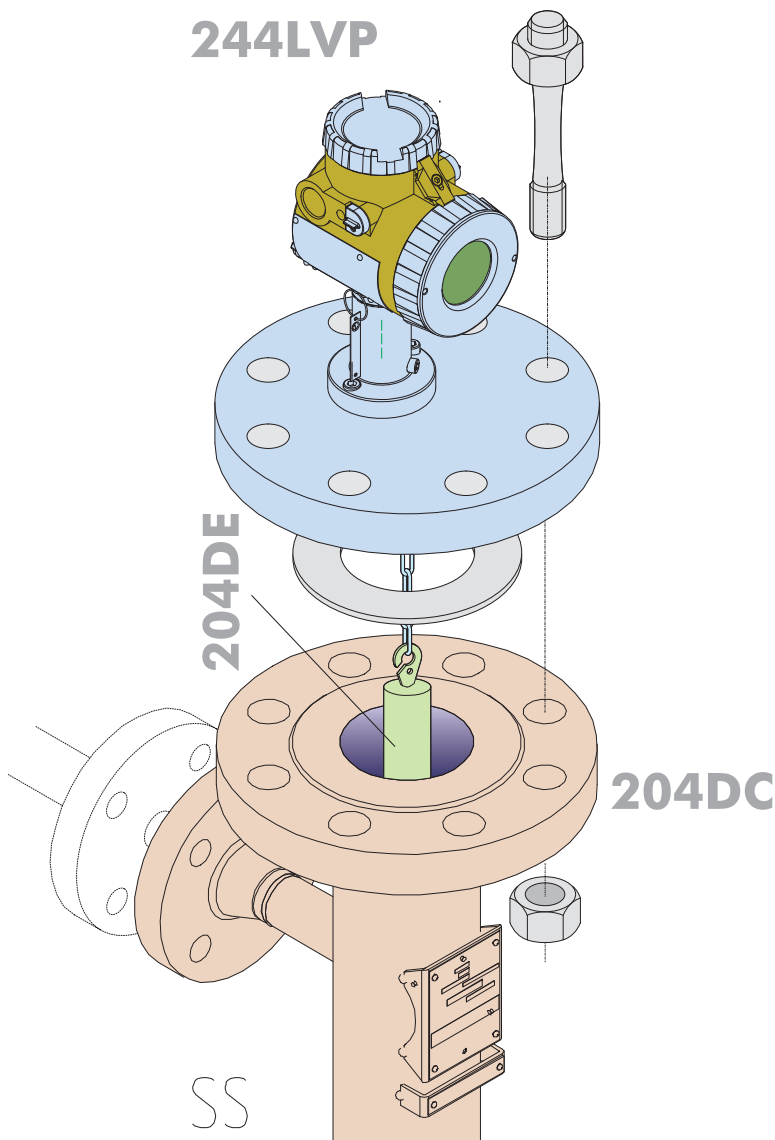

1 DESIGN

The transmitter is based on a modified pressure measuring cell. The sensor is a flexure beam, which is mechanically linked to the measuring diaphragm,

so the measuring cell also can be used for force measurement. The static pressure in vessel does not influence the measurement.

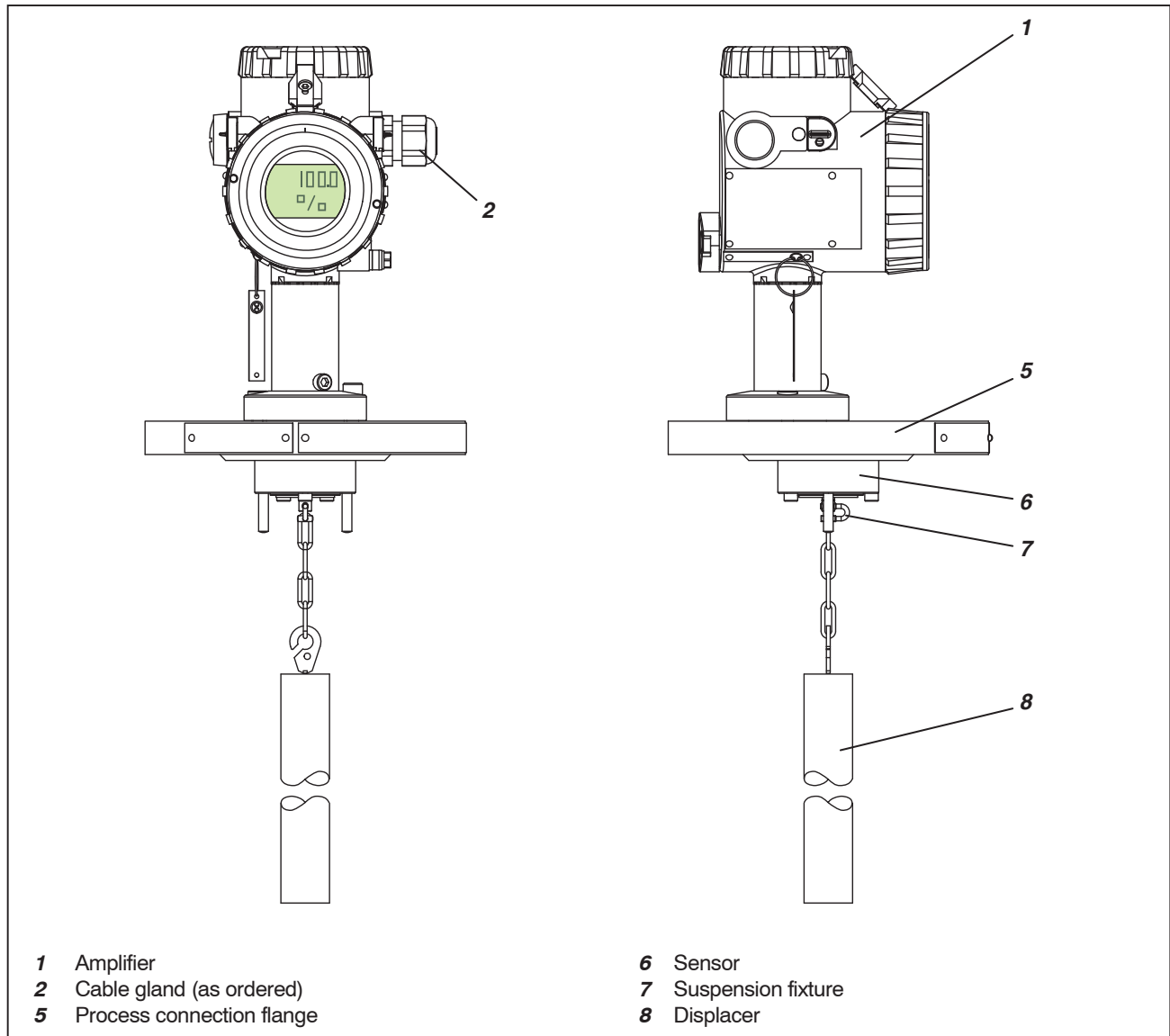

2 METHOD OF OPERATION

The buoyancy force of the displacer acts directly on the flexure beam. Four thin film metal resistors are sputtered onto the sensor element, which change their resistance in the ratio of the tensile or pressure tension. These four thin film metal resistors are connected as a

Wheatstone full bridge supplied from amplifier. The voltage at the diagonal bridge section which is proportional to the effective weight is fed to the electronic amplifier as an input signal.

See also chap 2.2 Block diagram.

3 IDENTIFICATION

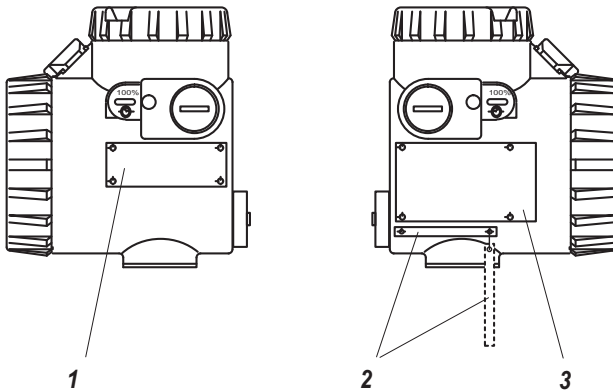

The transmitter is identified with three labels. The transmitter nameplate **3.1** shows the Model Code of the transmitter, which clearly describes the device. The certificate data and the serial No. are entered on the amplifier nameplate **3.3**. The TAG No. label **3.2** with the Tag No. is located underneath (optional). Data about the permissible static pressure and the displacer are documented on the data label **3.4** on the process connection flange.

3.1 Transmitter nameplate

(Example)

Device specification, Model Code

MESSUMFORMER / TRANSMITTER	
MODEL	244LVP - SS8C1BM-ZZZ
	-
	-
ECEP	-
REV.Nr.	-

ID No. for special version

3.2 Tag No. label

(Example)

Directly fixed or attached

LID 09/16

3.3 Amplifier nameplate

(Examples)

VERSTÄRKER / AMPLIFIER		CE
EBE	SER.No.	0102
KOMMUNIKATION		
<input type="checkbox"/> 4 ... 20 mA	<input type="checkbox"/> FOXCOM IT1	<input type="checkbox"/> PROFIBUS acc. FISCO
<input type="checkbox"/> HART	<input type="checkbox"/> FOXCOM IT2	<input type="checkbox"/> FF FIELDBUS H1
HILFSENERGIE POWER SUPPLY		AUSGANG / OUTPUT
invensys	Made in Germany by FOXBORO ECKARDT GmbH D - 70376 STUTTGART	FOXBORO ECKARDT

Without explosion protection

VERSTÄRKER / AMPLIFIER		CE
EBE	SER.No.	0102
KOMMUNIKATION		
<input type="checkbox"/> 4 ... 20 mA	<input type="checkbox"/> FOXCOM IT1	<input type="checkbox"/> PROFIBUS acc. FISCO
<input type="checkbox"/> HART	<input type="checkbox"/> FOXCOM IT2	<input type="checkbox"/> FF FIELDBUS H1
PTB Nr.	ATEX	TYPE
<input type="checkbox"/> Pi <input type="checkbox"/> Ui <input type="checkbox"/> li <input type="checkbox"/> Ci <input type="checkbox"/> Li <input type="checkbox"/> Tamb		
siehe Betriebsanleitung see Instruction Manual		
invensys	FOXBORO ECKARDT	Made in Germany by FOXBORO ECKARDT GmbH D - 70376 STUTTGART

With explosion protection acc. to ATEX

ELECTRICAL TRANSMITTER	
SER. No.	OUTPUT
IS FOR CL I; DIV 1, GRPS A, B, C & D; CL II, DIV 1, GRPS E, F & G; CL III; HAZARDOUS LOCATIONS	
SEE DRAW. []	
WARNING: SUBSTITUTION OF COMPONENTS MAY IMPAIR INTRINSIC SAFETY.	
SP	FM APPROVED
SUITABLE FOR CL I, DIV 2, GP A, B, C, D; SUITABLE FOR CL II, DIV 2, GP F & G; SUITABLE FOR CL III; WARNING: DO NOT DISCONNECT EQUIPMENT UNLESS POWER HAS BEEN SWITCHED OFF OR THE AREA IS KNOWN TO BE NON-HAZARDOUS. WARNING-EXPLOSION HAZARD-SUBSTITUTION OF COMPONENTS MAY IMPAIR SUITABILITY FOR CLASS 1, DIVISION 2.	
TYPE 4X	
CSA and FM: T4A @ 40°C MAX AMB; CSA: T3C @ 85°C; T4 @ 60°C MAX AMB	
FM: T4 @ 85°C MAX AMB	
DC 12 - 30 V	
FOXBORO ECKARDT	invensys
CE	

With explosion protection acc. to FM/CSA

3.4 Displacer and pressure rating

(Example)

When ordered with a displacer, the transmitter is supplied with an application nameplate mounted at the circumference of the process connection flange.

VERDRÄNGER DISPLACER	LÄNGE LENGTH	1000 mm	TÜ SW	PN	40	BAUJAHR YEAR	2004
	VOLUMEN VOLUME	1314 cm ³		DRUCK-TEMP. BEREICH	-30 +50 +120 °C		INHALT VOLUME
	GEWICHT WEIGHT	12.384 N		PRESSURE-TEMP. RATINGS	40 35 bar	WERKSTOFF MATERIAL	1.4404

Displacer specification per order

Temperature and pressure ratings

Nominal pressure

Flange material

maximum static pressure at 120 °C

4 MOUNTING

The transmitter is directly built onto the vessel or alternatively on a side-mounted displacer chamber 204DC. During installation, the permissible static pressure and the ambient temperature range must be observed (see chapter 3, "Identification").

Note:

Proceed with caution during all installation work.
Do not damage the diaphragm!
Do not drop the suspended displacer!
Avoid jointing!

4.1 Mounting on top of the vessel

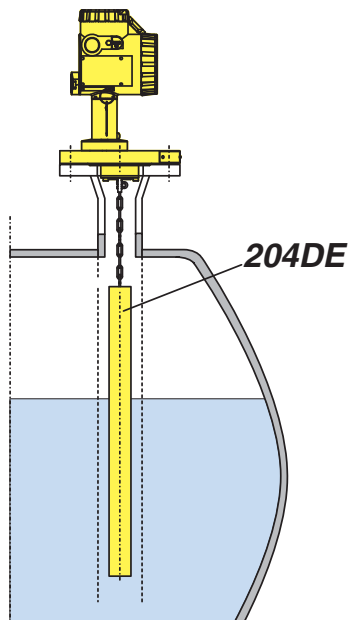

Transmitter at Connection flange
 Displacer 204DE in protection cage / tube

If the vessel contains a turbulent liquid a protection cage / tube should be used. If a tube is used, make sure there is a venting hole above maximum process level. Between the protection cage / tube and the displacer must be a gap of at least 5 ... 10 mm.

4.2 Mounting on the side of the vessel

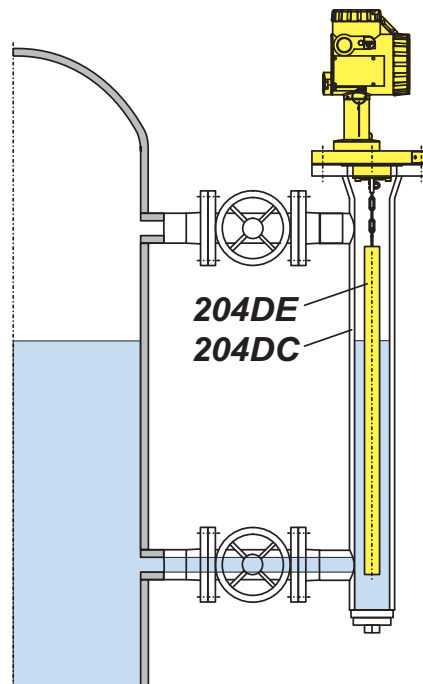

Transmitter and Shut-off device
 Displacer 204DE in Displacer Chamber 204DC

When used in Zone 0, fittings resistant to flame penetration must be used.

If the chamber has not already been mounted by the customer, it must be mounted to the vessel with suitable bolts and seals (not included in the scope of delivery). Be sure that the displacer chamber is exactly vertical.

Between the chamber and the displacer must be a gap of at least 5 ... 10 mm.

NOTE:

For explosion-proof devices or devices with certification as overfill protection according to WHG, the remarks in the product specifications PSS EML1710 A and in certificates or approvals must be observed.

4.3 Transmitter mounting

Ensure correct matching of transmitter and displacer while mounting. Each transmitter is calibrated for use with the respective displacer according to ordering data in the factory. Each displacer is marked with the TAG No. or, if not known, with the last three digits of the serial number of the respective transmitter. The corresponding displacer data (length, volume and weight) are specified on the adjustment data labels mounted on the process connection flange. See also chapter 3 "Identification".

Fit installation seal **139** on the flange **140** on the container side. Always use a new seal. The seal must be suitable for the flange size and the measured medium.

Attach displacer to suspension fixture **154** of transmitter. Long displacers can be placed in the container ahead of time. Multi-section displacers see chapter 4.4.

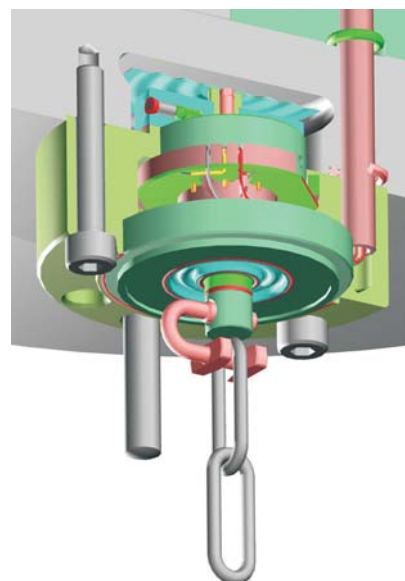
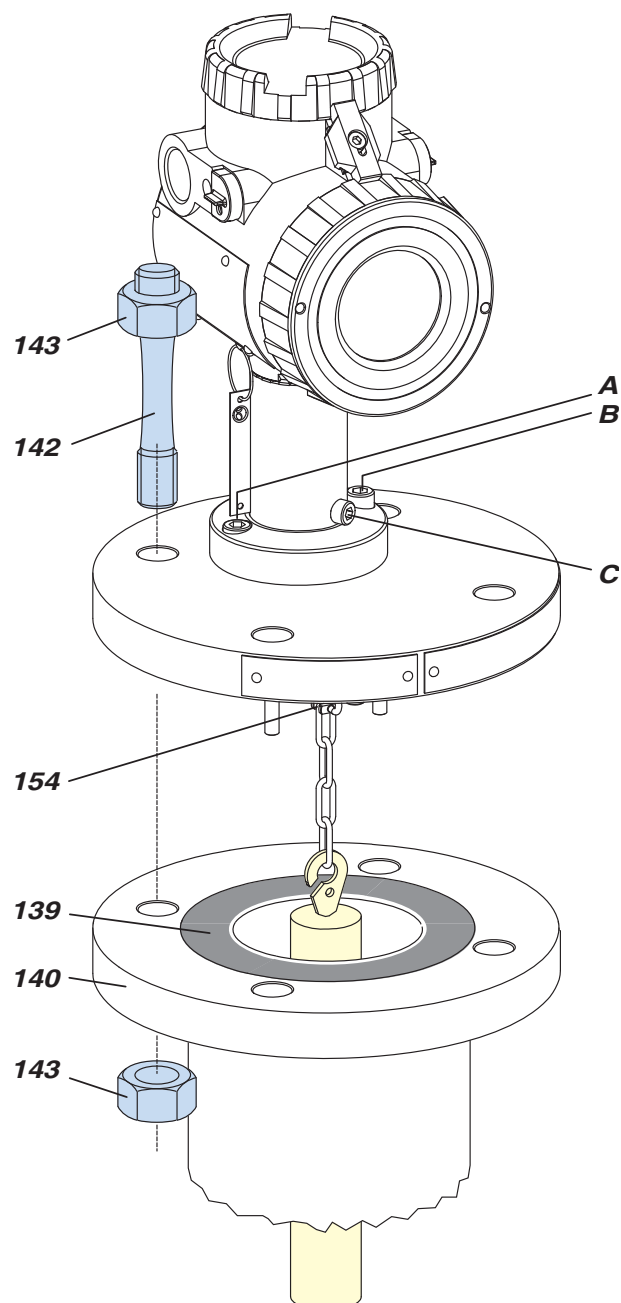

Carefully place transmitter and displacer onto the container flange **140**. Make sure the seal is accurately positioned. **Avoid impacts and jolting under all circumstances.** Tighten studs **142** and nuts **143**. Apply recommended torque (see tables below).

For comfortable reading the LCD, the upper section can be turned around nearly 360 degrees. For this loosen the screws **A** and **B** (but do not remove!)(SW5) and turn upper section into desired direction. Tighten again screws **A** and **B**.

The high screw **B** is stop for screw **C**. Thus it to prevent endlessly turning round of upper section that could damage the inside wires.

Rated pressure		Threaded bolt at rated diameter		
PN	Class	DN 80 / 3"	DN 100 / 4"	DN 70
16	150	M16	M16	–
40	300	M16 / M20	M20	–

Recommended torque (pre-stressed to 70 % of minimum yield point at 20 °C)									
Studs	Mat.	M16	M20	M24	M27	M30	M33	M36	M39
Tightening torque [Nm]	A2 *)	80	150	140	210	290	330	420	560
	GA	115	220	370	545	770	1000	1300	1750

*) Yield point for material A2 (acc. to DIN 267)	≤ M20	450 N/mm ²
	M24 to M30	250 N/mm ²
	> M30	210 N/mm ²

4.4 Displacer 204DE

Important

Displacer and transmitter must be matched properly during installation (see chapter 4.3).

Pressure Rating

The displacer must be designed for the pressure rating of the vessel - however, at least to the operating pressure - and ordered accordingly. Here the maximum possible temperature must be taken into consideration. Displacers made of PTFE are made from solid material, and are, therefore, suitable for all pressures (see Product Specifications PSS EML1710 A).

Jointed displacer elements

Displacers of length over 3 meters are jointed (multi-section) displacer elements. The displacer elements are screwed together and secured with the wire clip **151** to avoid bending or damage during insertion into the vessel. The elements of displacers with $\varnothing < 13$ mm are not screwed together; they are secured with hook and eyelet **152**. Additional securing is not necessary ¹⁾.

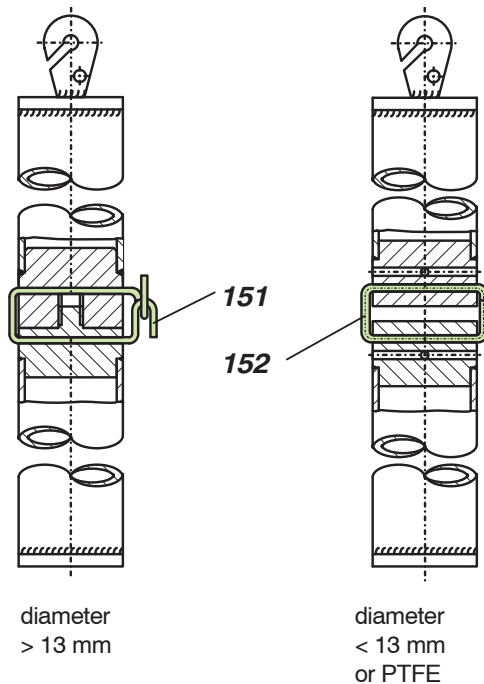

Damping element

In operating conditions with strong external vibrations - e.g. nearby compressor stations - the damping element (Option -D) should be used.

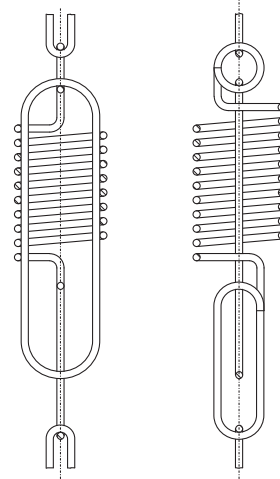

It is hooked onto the suspension chain of the displacer in place of 7 chain links (105 mm). This spring is specially matched to the resonance frequency of the displacer and is made of stainless steel (material 1.4310, max. operating temperature 250 °C).

Use in Zone 0 or as overfill protection acc. to WHG ²⁾

Mechanics

Displacers of more than 3 m length must be secured against oscillating when used in Zone 0.

When used as overfill protection according to WHG, the displacer must always be installed with guidance. Guidance devices over 3 m long must also be secured against bending.

Potential equalization

When used in Zone 0, only displacers of metal or PTFE + 25% carbon may be used.

A potential equalization line must be mounted as an electrical bypass of the displacer suspension(s) if the residual displacer weight is < 10 N, or if more than 6 contact points are present.

To avoid the danger of electrostatic ignition, a connection to the transmitter with good conductivity must be ensured. The volume resistance between the lower end of the displacer and ground may not exceed $10^6 \Omega$.

1) When used in Zone 0, the eyelets must also be welded.

2) Please see corresponding certificates for further details

5 ELECTRICAL CONNECTION

5.1 Signal wire connection

At both sides of the amplifier housing is a threaded hole (threads as ordered) for cable gland **38** or cover screw **39**.

The used cable glands have to conform to any Ex requirements. User assumes responsibility.

Actions:

- Remove cover lock **24** (if provided) and unscrew top housing cover **22**.
- Lead cable through screwed gland and connect with terminals **45**, **46** and **47**.
- If necessary connect external ground **48**.
- Screw top housing cover **22** and install cover lock **24** (if provided).

Note

For explosion-proof devices follow reference for cable gland and cover screw in document "Safety Operating Instructions 140 Series"

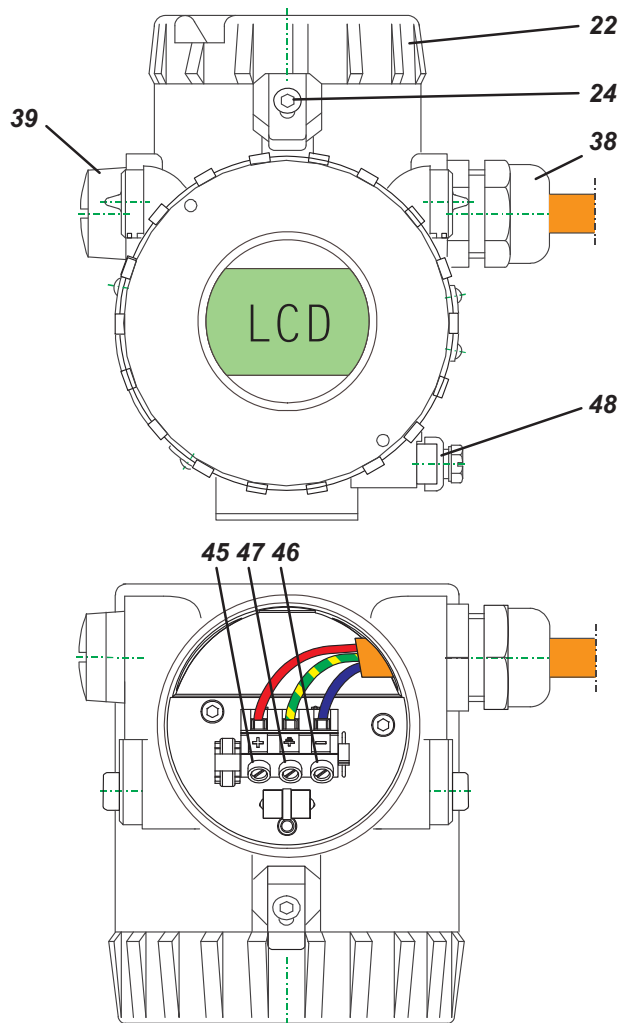

- 22** Top housing cover
- 24** Cover lock
- 38** Cable gland for cable with \varnothing 6 to 12 mm
- 39** Cover screw
- 48** External ground
- 50** Overvoltage protection (if present)
- 45** Connection terminal ¹⁾ +
- 46** Connection terminal ¹⁾ -
- 47** Ground terminal ¹⁾

¹⁾ wire cross section max. 2.5 mm²

6 COMMISSIONING

In any case, installation and safety regulations have to be checked prior to commissioning. See document EX EML 0010 A: **“Safety Operating Instructions”**

After correct installation and connection to power supply unit, the transmitter is ready for operation:

$$U > 12 \text{ V dc (HART)}$$

If necessary the configuration of lower range value, upper range value and damping has to be checked.

With HART an ammeter can be attached into the output current loop for check.

7 DECOMMISSIONING

Prior to decommissioning take precautions to avoid disturbances:

- Observe Ex. protection.
- Switch off power supply.
- Caution with hazardous process media!
With toxic or harmful process media, observe relevant safety regulations.

Before dismantling the transmitter, the procedure below should be followed:

- Depressurize vessel or displacer chamber.
- Drain off measuring medium in displacer chamber.
- Protect the environment; do not allow measuring substance to escape. Catch and dispose them properly.

The procedure for dismantling the transmitter is the reverse of that described for mounting.

8 SETTING OF TRANSMITTER

Zero, lower range value, upper range value and damping of the transmitter are set by manufacturer as specified in the order:

- Dimensions of displacer: Length, density, weight
- Setting Lower Range Value by weight F_0 :
without Zero elevation = 0;
with Zero elevation = Value of elevation
- Upper Range Value corresponding to buoyancy force of displacer (see Chap.9)
- Output Range and unit

Therefore, calibration at start-up is not necessary.

Operating data and displacer data are stored in the transmitter according to the order.

Configuration becomes necessary if this data deviates from the stored values.

In case the order does not include this data, the transmitter is supplied as follows:

displacer weight	=	1.500 kg
buoyancy force	=	5.884 N (0.600 kg)
indication	=	0 ...100 %
damping	=	8 sec (90 % time)

Setting via HART Protocol

- Setting with PC and FDT-DTM
- Setting with Handterminal

Setting via operating push buttons

Setting can be done by means of the push buttons at the transmitter, see next page.

Setting and Operation via FDT-DTM (recommended):

Starting operation

After starting (after power-on) the Foxboro Eckardt logo is briefly displayed,

then **Device Info ...**

244LVP LevelTransmitter V 0.45.1158 H	Device Type
	Measuring task
	Version

... and then the **operational view:**

7.099 m3 [] A	Measured value
	Status line
	Status line: padlock = protected
	A Autorange mode
	M Manual mode
	[] Measured value in bar chart
m3 physical unit, or %	

The operational view is the display in normal operation.

Manually or Autorange?

When ordering, the customer has stated range and the density of the measuring medium (or the densities of the media). From these informations the real displacer was manufactured.

On delivery the mode is set to Autorange: The displacer data (diameter, length, weight) and the density of the media were stored before delivery via FDT / DTM in the 244LVP LevelStar. From this data, PV-offset and Upper Range Value URV are calculated automatically, which allows an immediate operation without any additional calibration in the field.

However, if the manual method is preferred, so the values can be entered manually.

In Manual mode the classic method is possible to take over the respective values of the buoyancy forces with the operating conditions for 0 % (with level: empty vessel) and 100 % (with level: full vessel).

Important Note:

On the following pages, the operation of the transmitter is described using the local keys.

For the setting of all the values and special functions, we strongly recommend the use of the FDT-DTM Technology.

Therefore just a PC (notebook) is required, a modem, and the FDT software, which you can download for free from our web site.

The operation is much easier and more comfortable, additional functions are available which are not accessible with local keys.

Setting via local keys and LCD

The operating parameters and settings can be viewed on site and in some cases changed.

For local operation a full graphic LCD is available and 2 buttons on the outside of housing.

Inside the unit there are no other controls.

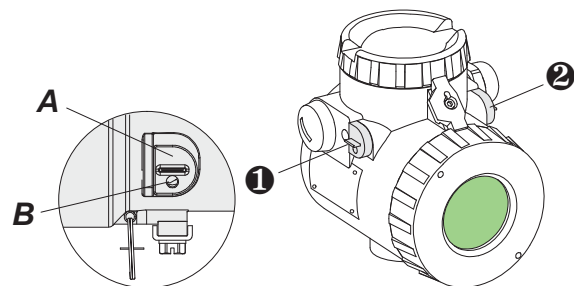

- ① = Left button
- ② = Right button

After shifting the key protection cap **A**, insert screw driver or pin ($\varnothing < 3$ mm) into hole **B** and press down to the second pressure point.

Starting from operational view,

- the ② button switches to details of the operating values
- the ① button switches to the menu selection, see illustration on the next page.

If no button is pressed within 5 minutes, the display returns automatically to the operational view.

Changing values

Linear adjustment

Is used for example in PV-offset, damping and LCD contrast:

The current value is displayed. With button ② MORE the value is increased. If the largest value is reached, starts again from beginning with the smallest value. The button has auto repeat.

Stop with button ① DONE. After that, even queried whether the change should be saved.

Numerical adjustment

Is used for example in measuring range values:

The current value is displayed and the first digit (or sign) is selected. Each time the button ① CHANGE is pressed the number is counted up, until the desired number is reached. With button ② NEXT the next number is marked and can be changed, etc.

After that, even queried whether the change should be saved.

Operational view

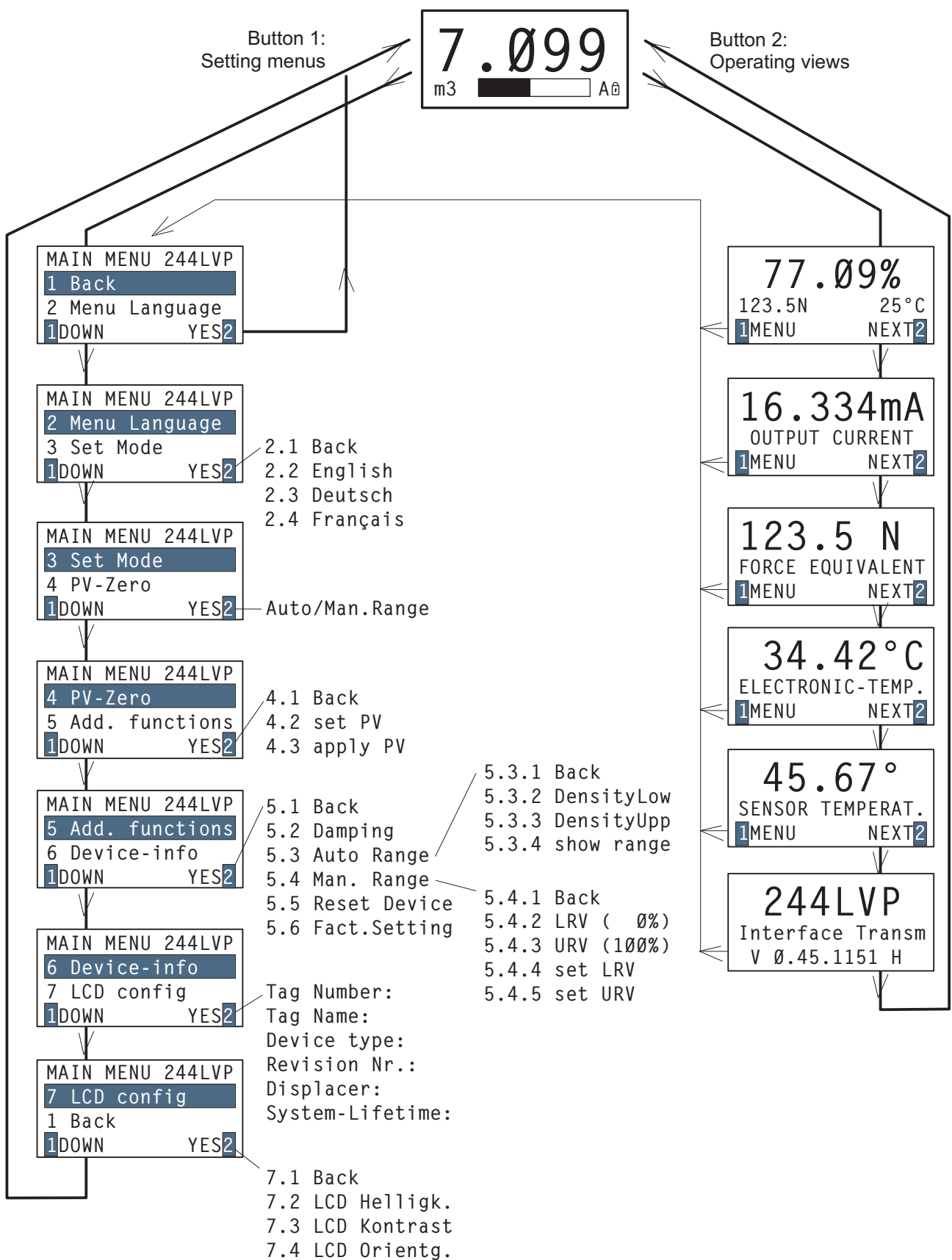

Menu 1: Back



Back to Operational view.

--> When selecting YES 2 it goes **back to the operating view**.

Note: All sub-menus start with a "back" feature that lets you come back to the previous menu. For better clarity omitted in this description.

Menu: Menu language

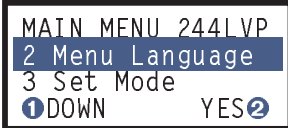

--> With YES 2 it goes to **language selection**:

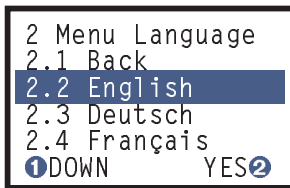

There are 3 menu languages, standard English, German and French. From the factory, active language is always English.

With 1 DOWN the desired language is selected and becomes active with confirming with YES 2. All texts are now displayed in the chosen language. Then it goes automatically **back to the main menu**.

Menu 3: Set mode

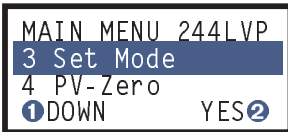

--> With YES 2 it goes to **Autorange- or Manual-** selection. See also notes on page 10

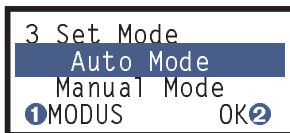

With 1 MODE you switch from Autorange- to Manual Mode. If this is to expect a change in the output value, a message appears.

After confirming with OK 2 back to the main menu. Switching from Manual- to Autorange Mode: Requires reset to factory settings, if manual set data allows no calculations. See menu 5.6.

Menu 4: Setting PV-Offset

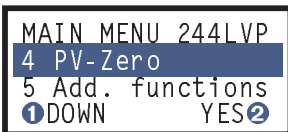

--> With YES 2 it goes to setting **PV-Offset**:

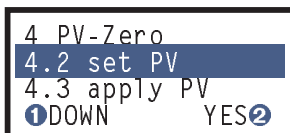

--> With YES 2 PV-Offset can be set, regardless of the mode Autorange or Manual.

Setting on Linear adjustment in 0.1% increments, see p.10

The expected impact of the change can be seen on the primary variables in the second line.

The resulting automatically calculated PV-offset is displayed on the third line to observe the change and possibly return to the former value.

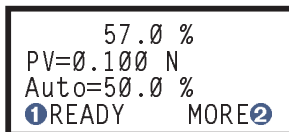

```

4 PV-Zero
4.3 apply PV
4.1 Back
1DOWN      YES2

```

--> With YES 2 the current process value (Level: Displacer not in the medium) is taken over as the physical zero point.
This menu item is only for manual mode and therefore the auto range mode is locked (indicated by a padlock symbol).

```

< 5.000N >
  apply as 0%?
LRV= 0.000 N
1NO      YES2

```

--> By confirmation with YES 2 the current value will be saved as Lower Range Value.

Menu 5: Additional functions

```

MAIN MENU 244LVP
5 Add. functions
6 Device-info
1DOWN      YES2

```

--> With YES 2 it goes to the following sub menus:

```

5 Add. functions
5.2 Damping
5.3 Auto Range
1DOWN      YES2

```

--> With YES 2 it goes to **setting the damping**.

```

5.2 Damping
    08 sec.
[  |  ]
1READY  MORE2

```

At first the current value is displayed.

The value can now be adjusted with the 2 button in steps of 1 sec.
 Linear adjustment, see page 10.
 Then back to the menu.

```

5 Add. functions
5.3 Auto Range
5.4 Man. Range
1DOWN      YES2

```

--> With YES 2 it goes to the **Range setting in the Autorange mode**.
In Autorange mode, the densities can be changed and then immediately taken into account in the automatic calculation.

```

5.3 Auto Range
5.3.2 DensityLow
5.3.3 DensityUpp
1DOWN      YES2

```

--> With YES 2 to enter the **density of the lower medium**.

```

5.3.2 DensityLow
+1000.00 kg/m³
1EDIT      NEXT2

```

The value is entered using Numerical adjustment, see page 10.
 Finally, the value must be confirmed and is saved.
If density of lower medium is lighter than the density of upper medium, an error message appears and the value is not stored.

```

5.3 Auto Range
5.3.3 DensityUpp
5.3.4 show range
1DOWN      YES2

```

--> With YES 2 to enter the **density of the upper medium**.
(Proceed as with lower density.)
 Note: For Level measurement the value is 0.000.

```

5.3 Auto Range
5.3.4 show range
5.3.1 Back
1DOWN      YES2
    
```

--> With YES 2 the current Measuring range is displayed:

```

Range=100.00 N
LRV= 0.00 N
URV= 100.00 N
      BACK2
    
```

Measuring range
Lower Range Value
Upper Range Value
--> With BACK 2 back to previous menu.

```

5 Add. functions
5.4 Man. Range
5.5 Reset Device
1DOWN      YES2
    
```

--> With YES 2 it goes to the **Range setting in Manual mode.**
After setting the operating conditions for 0 % (at level: vessel empty) or 100 % (at level: vessel full) each take over the value of the buoyancy force. Or by values input at 0 % and 100 %.
Note: Feature is only available in Manual mode, Autorange mode is locked (padlock icon in the LCD).

```

5.4 Man. Range
5.4.2 LRV ( 0%)
5.4.3 URV (100%)
1DOWN      YES2
    
```

LRV - take over the Lower Range Value (0 %)

--> With YES 2 the following display appears:

```

< 5.000N >
  apply as 0%?
LRV= 0.000 N
1NO      YES2
    
```

--> By confirmation with YES 2 the current value will be saved as Lower Range Value.

```

5.4 Man. Range
5.4.3 URV (100%)
5.4.4 set LRV
1DOWN      YES2
    
```

URV - take over the Upper Range Value (100 %)
(Proceed as with Lower Range Value.)

```

5.4 Man. Range
5.4.4 set LRV
5.4.5 set URV
1DOWN      YES2
    
```

LRV - enter the Lower Range Value (0 %)

--> With YES 2 the following display appears:

```

5.4.4 set LRV
+010.000 %
min= 000.000 %
1EDIT      NEXT2
    
```

The value is entered using Numerical adjustment, see page 10.
In the third line, the minimum value is displayed.
Finally, the value must be confirmed and is then stored as Lower Range Value.

```

5.4 Man. Range
5.4.5 set URV
5.4.1 Back
1DOWN      YES2
    
```

URV - enter the Upper Range Value (100 %)
(Proceed as with Lower Range Value.)

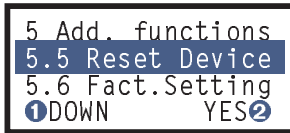

--> With YES 2 it goes to function selection.
After a further confirmation the reset of electronics is running.
Same effect as Power-on.

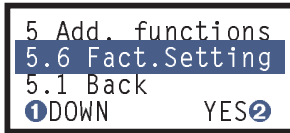

--> With YES 2 it goes to function selection.
WARNING: According to a further confirmation, **all custom settings are reset to the factory-defined state** and will be lost.

Menu 6: Device informations



--> YES 2 displays the data stored in the transmitter, such as
Tag Number
Tag Name
Device type
Revision Nr
Displacer data
System-Lifetime

Menu 7: LCD configuration



--> With YES 2 it goes to **settings for the LCD**:

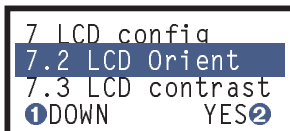

--> With YES 2 it goes to selection of **LCD orientation**:

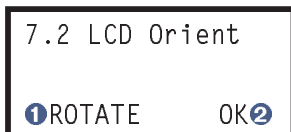

--> With 1 ROTATE is the text "on the feet".

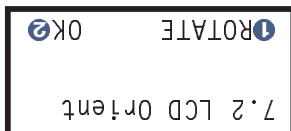

--> With confirming with OK 2 it goes back to the menu.

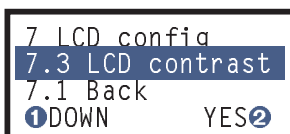

--> With YES 2 the LCD contrast is adjusted.
Linear adjustment, see page 10.

9 DIMENSIONING OF DISPLACER

CALCULATING WEIGHT FORCES (also see VDI/VDE-Guideline 3519, sheet 1)

Displacer length = measuring range

Measurement type	Weight forces		0 %	100 %
	Lower range value = 0 % output signal	Upper range value = 100 % output signal		
Liquid level (ρ_2 = negligible) 1)	$F_0 = F_G$	$F_{100} = F_G - V \cdot g \cdot \rho_1$		
Interface (ρ_2 = not negligible)	$F_0 = F_G - V \cdot g \cdot \rho_2$			
Density (ρ_2 = min. density, ρ_1 = max. density)				

**Displacer length > measuring range
(without elevation)**

Measurement type	Weight forces		0 %	100 %
	Lower range value = 0 % output signal	Upper range value = 100 % output signal		
Liquid level (ρ_2 = negligible) 1)	$F_0 = F_G$	$F_{100} = F_G - V \cdot g \cdot \rho_1 \frac{h_b}{L}$		
Interface (ρ_2 = not negligible)	$F_0 = F_G - V \cdot g \cdot \rho_2$	$F_{100} = F_G - V \cdot g \left(\rho_1 \frac{h_b}{L} + \rho_2 \frac{L - h_b}{L} \right)$		

**Displacer length > measuring range
(with elevation)**

Measurement type	Weight forces		0 %	100 %
	Lower range value = 0 % output signal	Upper range value = 100 % output signal		
Liquid level (ρ_2 = negligible) 1)	$F_0 = F_G - V \cdot g \cdot \rho_1 \frac{h_0}{L}$	$F_{100} = F_G - V \cdot g \cdot \rho_1 \frac{h_0 + h_b}{L}$		
Interface (ρ_2 = not negligible)	$F_0 = F_G - V \cdot g \left(\rho_1 \frac{h_0}{L} + \rho_2 \frac{L - h_0}{L} \right)$	$F_{100} = F_G - V \cdot g \left(\rho_1 \frac{h_0 + h_b}{L} + \rho_2 \frac{L - h_b - h_0}{L} \right)$		

- F_G [N] Weight force of displacer in atmosphere
- F_0 [N] Weight force action on suspension point of displacer at lower range value
- F_{100} [N] Weight force action on suspension point of displacer at upper range value
- F_A [N] Buoyancy force of displacer ($F_A = F_0 - F_{100}$)
- V [m³] Displacer volume (specified on data label in cm³!)

- ρ_1 [kg/m³] Liquid density
- ρ_2 [kg/m³] Density of gas or lighter liquid
- g [m/s²] Local acceleration due to gravity (e.g. 9.807 m/s²)
- L [m] Displacer length
- h_0 [m] Lower range value
- h_b [m] Measuring span

Attention: 1 kg generates a force of 9.807 N

1) ρ_2 is negligible if ρ_2 = gas at atmospheric pressure or with ratio $\rho_2 : \rho_1$ less than 0.5 %.

Graph for determining displacer diameter

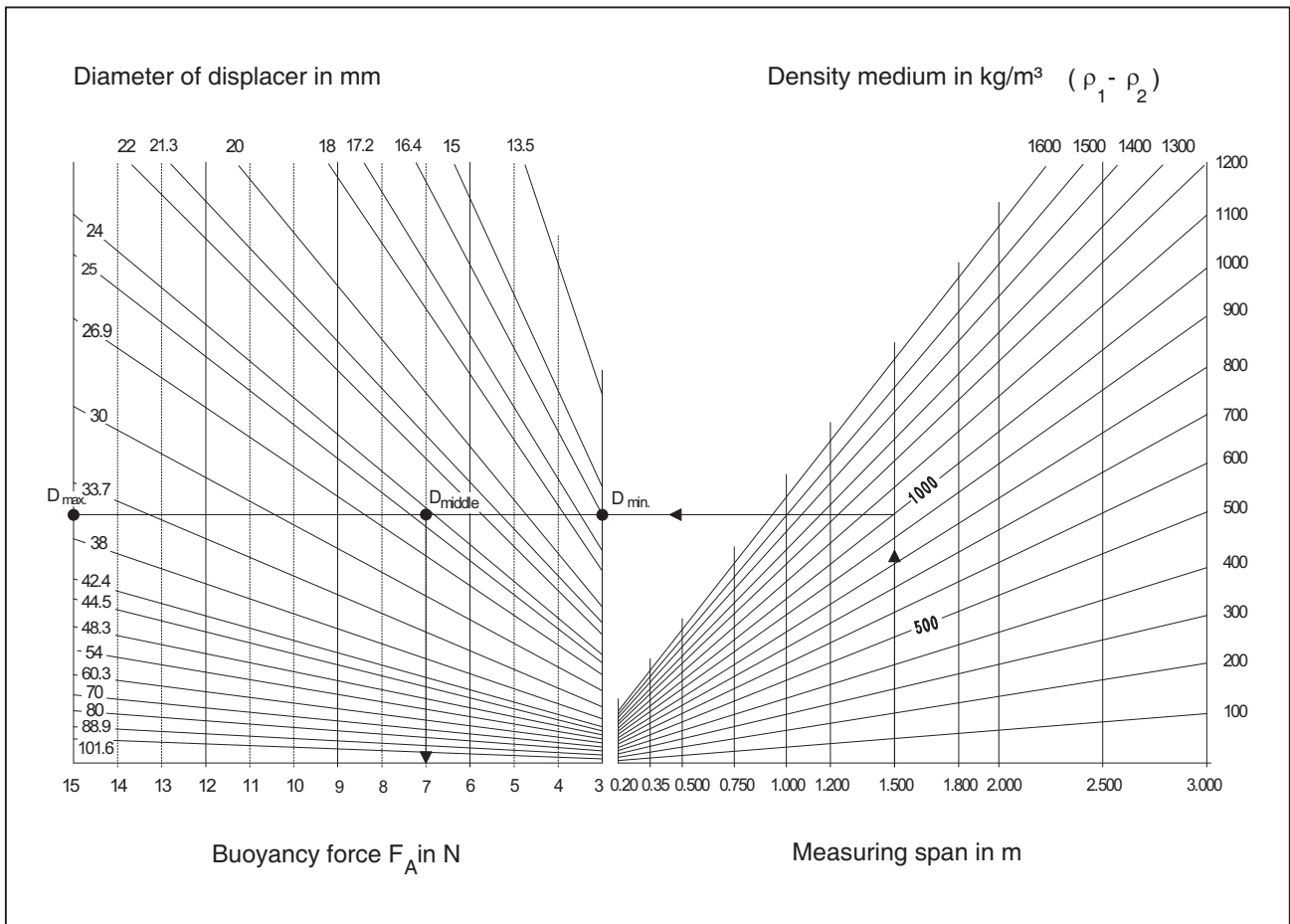

Measuring span

The transmitter is designed for a buoyancy force measuring span of minimum 2 up to maximum 20 N.

Weight force

The maximum weight of the displacer F_G max. is 40 N for level measurements. For density or interface measurements, the displacer must be dimensioned so that after deducting F_A of the lighter process media, the remaining force F_0 does not exceed 40 N.

Determining displacer diameters

To make optimum use of the transmitter, the displacer should be dimensioned so that the greatest possible buoyancy force is generated over the measuring range. On the other hand, the maximum possible diameter of the displacer must be taken into consideration.

In the above graph the displacer diameter can easily be estimated dependent on the measuring span and the buoyancy force.

The following equation can be used to exactly dimension the displacer:

$$D = 1000 \sqrt{\frac{4 F_A}{\pi g (\rho_1 - \rho_2) L}} \quad [\text{mm}]$$

D = Outside diameter of displacer in mm

F_A = Buoyancy force of displacer in N

g = Acceleration due to gravity (9.807 m/s²)

ρ_1 = Density of heavier liquid in kg/m³

ρ_2 = Density of gas or lighter liquid in kg/m³

L = Measuring span in mm

Example:

Measuring span: 1.500 m

ρ_1 = 1000 kg/m³

ρ_2 = negligible

10 Measuring principle

(see VDI/VDE Guideline 3519, sheet 1)

Any body immersed into a liquid is subject to Archimedian buoyancy force which depends on the liquid density. This is exploited to determine liquid level, density and interface level by suspending a displacer with constant cylindric shape into a liquid.

Changes in buoyancy forces are proportional to liquid level changes and are converted to a measuring signal.

The displacer is fully immersed for density and interface level detection. It is important that the position of the displacer changes as little as possible over the measuring range.

The following applies in general to the buoyancy force acting on the displacer:

$$F_A = V_x \cdot \rho_1 \cdot g + (V - V_x) \cdot \rho_2 \cdot g$$

- F_A Buoyancy force
- V Volume of displacer
- V_x Volume of medium displaced by measuring body with density ρ_1
- ρ_1 Average density of heavier medium
- ρ_2 Average density of lighter medium
- g Local acceleration due to gravity
- F_G Displacer body weight force

The force acting on the transmitter is inversely proportional to liquid level changes.

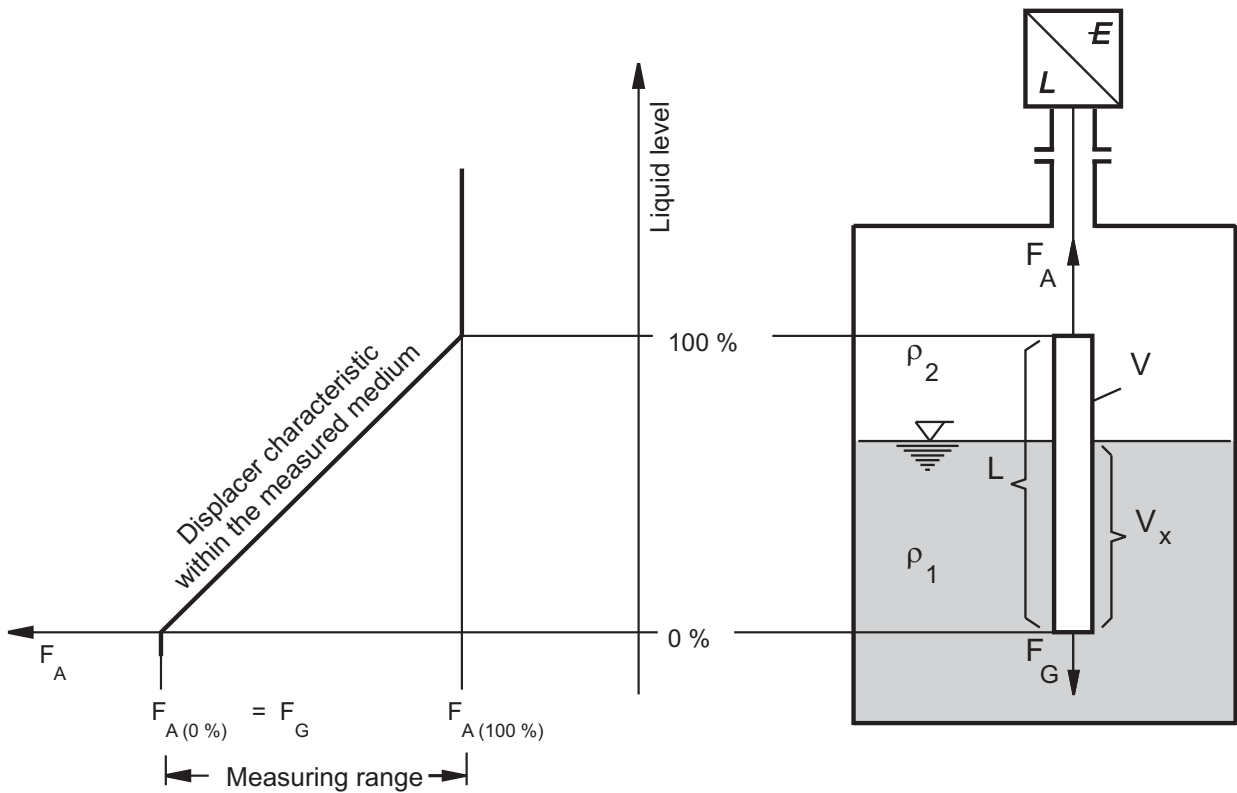

10.1 Block diagram with HART communication

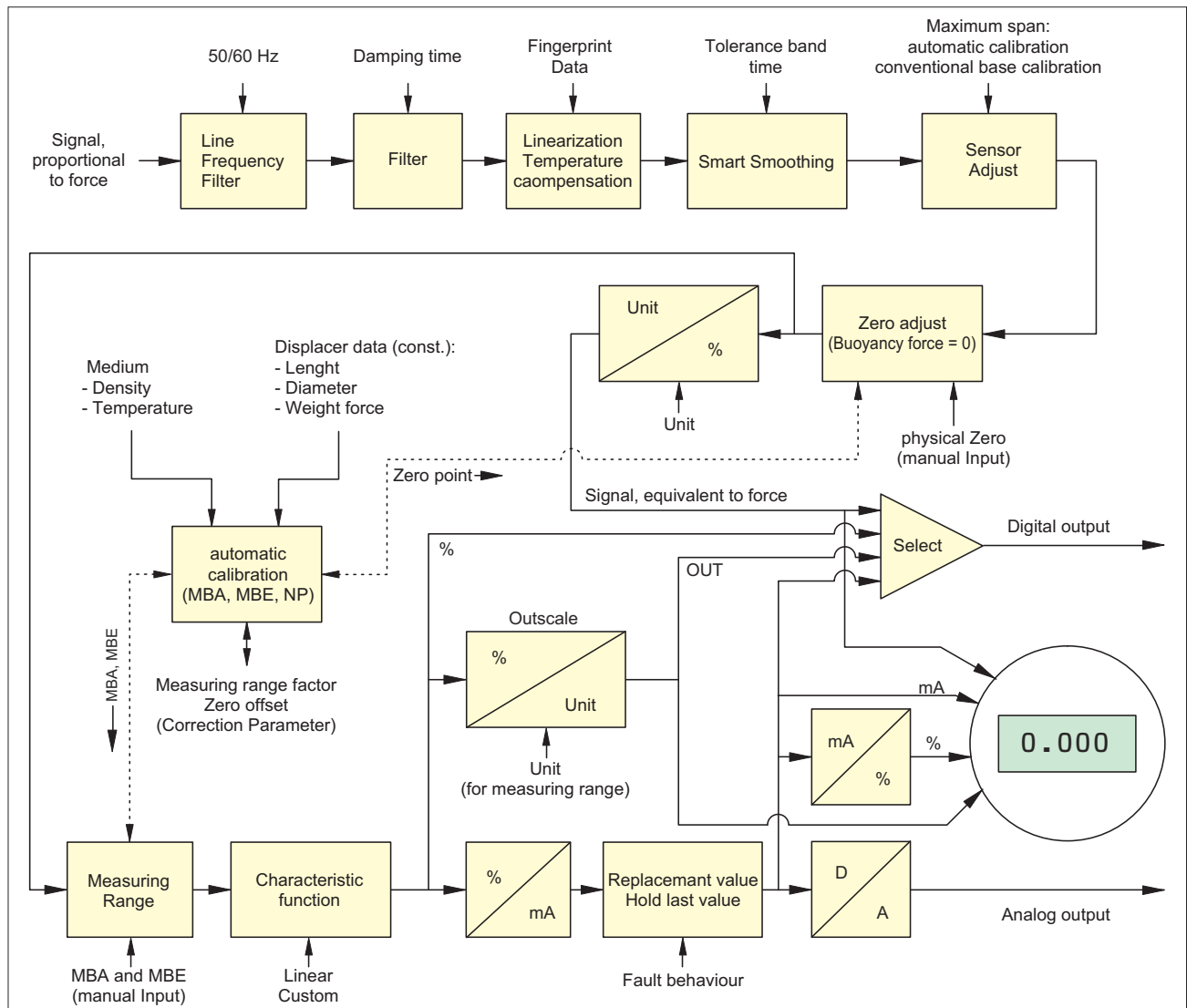

10.2 Explanations to Block diagrams

Sensor

The force sensor is a Wheatstone bridge of four metal strain gauge elements and a Ni100 resistor for temperature measurement.

Line Frequency Suppression Filter

There is the selection to filter the noise signal 50 Hz or 60 Hz.

Linearization and Temperature compensation of Sensor characteristic

The sensor signal is linearized and temperature-compensated by the included sensor temperature. Linearization takes place via the so-called fingerprint data, which are determined during the production for each sensor. In factory the fingerprint data are loaded into the amplifier.

Smart Smoothing

In factory the Smart Smoothing Band is set to 2 % of sensor range. The Integration Time of the average value is set to 10 sec.

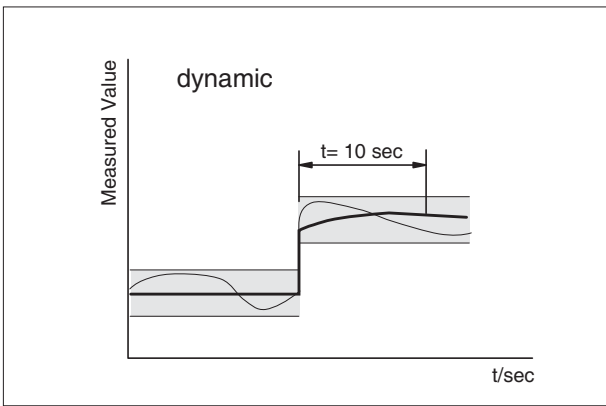
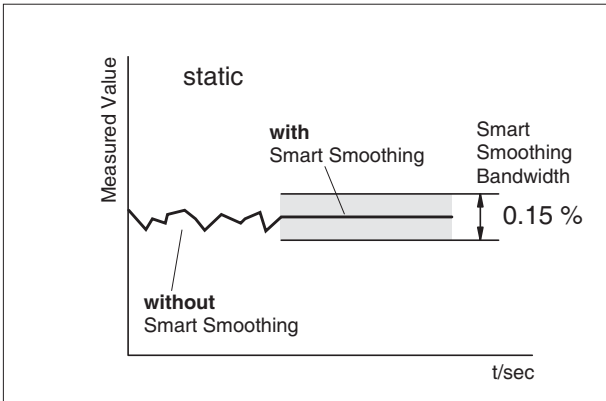

Sensor Adjustment

Zero and span of force sensor are adjusted in factory. It is possible to calibrate Zero (situation alignment) with the external key.

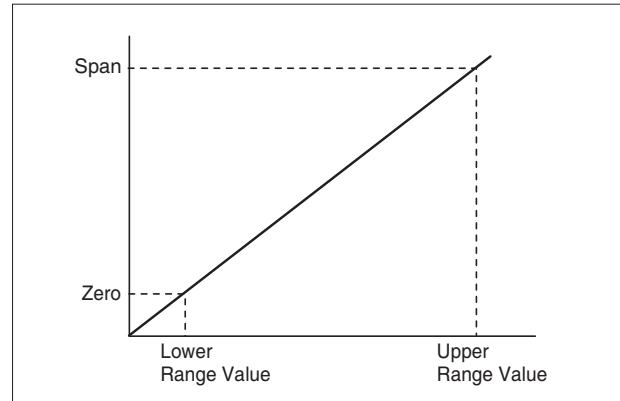

Transfer function / Characteristic

The characteristics are available linear, root-extracted and customized. With "customized" there are 32 x/y- values available. Standard with Level is "linear".

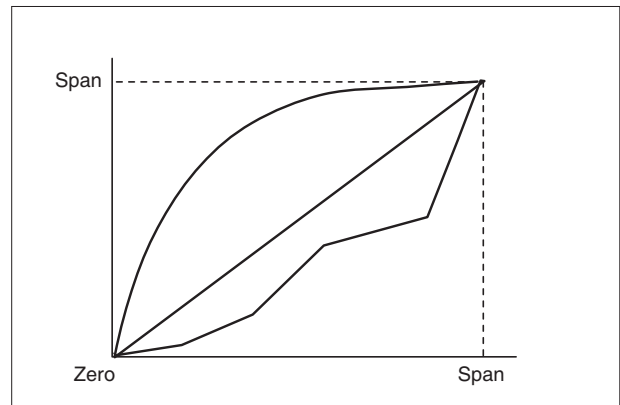

Measured Value Setting

The user can define measured value and unit.

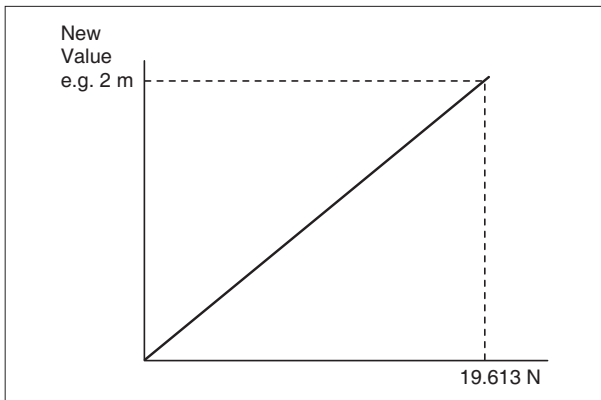
**Setting of Output value**

The output value is the measured value between Lower Range Value and Upper Range Value. Value and unit are freely selectable. The replacement value affects the output.

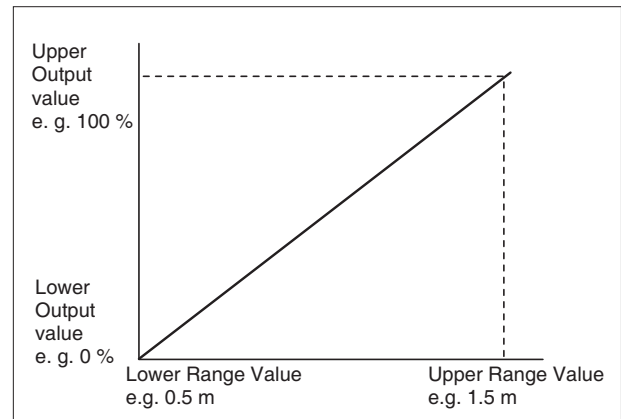
**Setting of Range**

The measuring range is the range between Lower Range Value and Upper Range Value. Lower Range Value is the weight of the displacer. Lower Range Value without elevation is 0. With elevation, the value of elevation has to be entered.

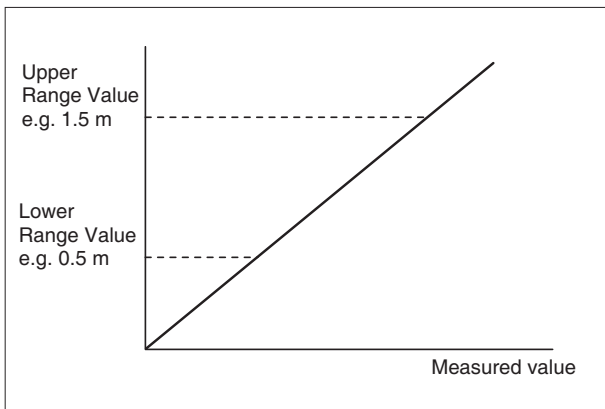
**Replacement / Substitute Value (HART only)**

In case of error output holds last value or gives a configurable Replacement value.

If the error does not exist any longer, then "last value" and/or replacement value is taken back (automatic or manually).

Multi-drop (HART only)

With FDT-DTM or a Hand Held Terminal it is possible to switch

- HART-Amplifier between "analog" and "Multi-drop"
- FoxCom-Amplifier between "analog" and "digital".

With HART-mode "Multi-drop" the output has a digital signal, the measured value is modulated to a 4 mA DC signal.

FDT-DTM Software enables to simulate the measured value and to write output values directly to the output.

Filter

The output signal is damped. Damping time ist setable from 0 to 32 sec.

11 SUPPLY OF TRANSMITTER

11.1 General

Depending on the transmitter application varying demands are made on the supply. The different operating modes are explained in the following chapters. The wire diagrams are shown in the following figures.

The power supply units for different applications (direct / via power supply unit of transmitters, HART / without communication, intrinsically / not intrinsically) are listed in the following table.

All listed supply devices are available for intrinsically-safe and/or non-intrinsically-safe application.

Application and associated supply

Application	Supply (recommended)
without communication	direct, MT228
HART	direct, MT228

11.2 Overview of application types

Supply via power supply unit (Fig. 1)

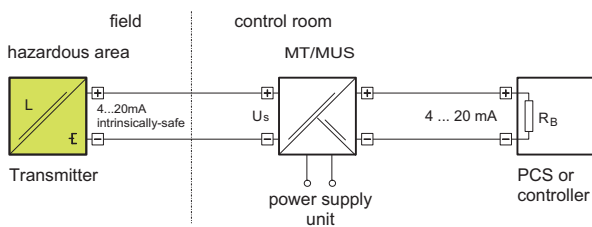

Direct supply (Fig. 2)

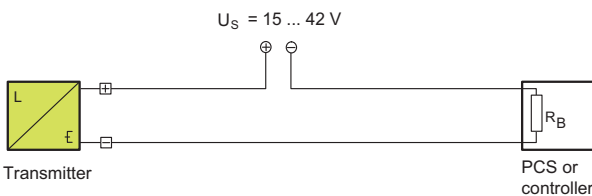

Supply via power supply unit with communication (Fig. 3)

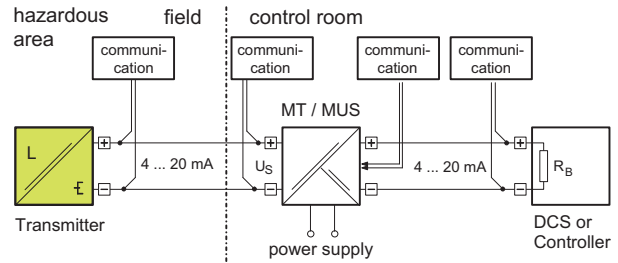

Direct supply with communication (Fig. 4)

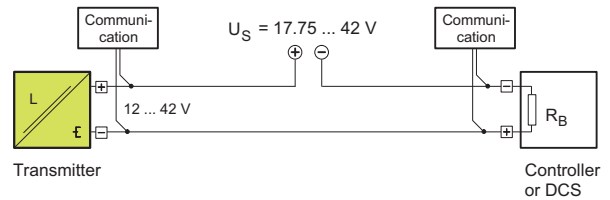

11.2.1 Supply via power supply unit

This supply is recommend for normal use. Interferences are prevented due galvanic separation of measurement loop, load and power supply in the power supply unit (see fig. 1)

11.2.2 Direct supply

This most simple version can be recommended only for single galvanically separated supply or measurement loops (see fig. 2)

The max. load impedance is calculated per:

$$R_{Bmax} = (U_{max} - 12 V) / I_{max}$$

U_{max} : max. permitted voltage (acc. to product specifications), depends on type of transmitter and explosion protection

I_{max} : 12 mA for transmitter in FOXCOM digital mode, 23 mA for all other transmitters (HART and FOXCOM)

Permissible load depending on supply voltage.

Example of a non intrinsically safe 140 series HART transmitter (Fig. 6)

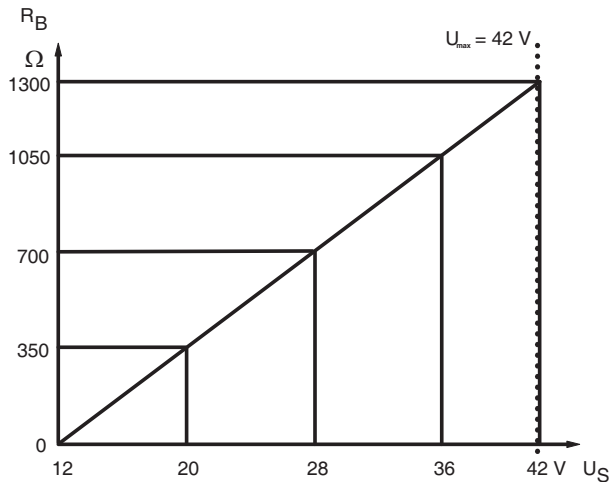
**11.2.3 Communication**

In contrast to conventional operating mode in the two-wire loop **a minimal load for all communication modes** has to be available. If this load is selected too low, the communication is short-circuited.

(FOXBORO ECKARDT power supply units capable for communication MT228 already have respective loads).

Additionally, the line lengths have to be limited to the max. permitted values for the respective communication

Standard values

Communication	HART		
Min. load	250 Ω		
Max. capacity of line	< 200 nF		
Max. length of line	~ 3300 m		

The respective wiring diagram is shown in Figure 3.

Figure 4 shows the respective wiring diagram without power supply unit for galvanically separated loops. The operating tool - handterminal, PC with FDT-DTM software and modem - can be connected to the labeled positions. Depending on the application the regulations for explosion protection have to be observed also for the operating tools!

11.2.4 Intrinsically-safe application

For intrinsically-safe application generally the use of a respective power supply unit is recommended. Wiring should be done as per respective national and international standards and regulations - as described in "Supply via power supply unit". If communication is required also, the guidelines of chapter "Communication" have to be observed. In addition, the application of the operating tools and their permitted limit values are to be observed.

Product Specifications for Intelligent Transmitters

Product Specification: Device:

PSS EML0610	144LD	Intelligent Buoyancy Transmitter for Liquid Level, Interface and Density with Displacer and Torque Tube
PSS EML0710.A	244LD	Intelligent Buoyancy Transmitter for Liquid Level, Interface and Density with Displacer and Torque Tube
PSS EML1610	144LVD	Intelligent Buoyancy Transmitter for Liquid Level, Interface and Density with Displacer
PSS EML1710	244LVP	Intelligent Buoyancy Transmitter for Liquid Level, Interface and Density with Displacer
PSS EML0901	204xx	Accessories for Buoyancy Transmitters
PSS EMO0100		Accessories for Devices with HART-Protocol

Subject to alterations - reprinting, copying and translation prohibited. Products and publications are normally quoted here without reference to existing patents, registered utility models or trademarks. The lack of any such reference does not justify the assumption that a product or symbol is free.

FOXBORO ECKARDT GmbH
Pragstr. 82
D-70376 Stuttgart • Germany
Tel. +49 (0)711 502-0
Fax +49 (0)711 502-597
e-mail: salesupport@foxboro-eckardt.de
<http://www.foxboro-eckardt.eu>



DOKT 556 882 049~1

i n v e n s y s
Operations Management