

**I/A Series® MagEXPERT Flow Transmitter  
Model IMT96**

**with  
2800 Series Flanged Flowtubes  
Installation**



# Contents

Figures.....	v
Tables.....	vi
<b>1. Introduction .....</b>	<b>1</b>
Overview .....	1
Reference Documents .....	1
General Description .....	1
Standard Specifications .....	3
Electrical Safety Specifications .....	7
Transmitter Identification .....	8
<b>2. Mounting.....</b>	<b>9</b>
Unpacking and Handling Procedure .....	9
Transmitter Dimensions .....	9
Transmitter Door .....	9
Transmitter Mounting .....	10
Surface Mounting .....	10
Pipe Mounting .....	11
Panel Mounting .....	12
<b>3. Wiring.....</b>	<b>13</b>
Wire Entrances and Conduit Connections .....	13
Conduit Hole Plugs .....	14
Optional Cable Glands for Nonconduit Applications .....	14
Access to Terminals .....	15
Wiring Flowtube to Transmitter .....	15
Recommended Wire Specifications .....	15
Signal Wires .....	15
Foxboro Cable .....	15
Twisted Shielded Pair Cable .....	15
Coil Drive Wires .....	16
Wire Preparation .....	16
Signal Cable – Transmitter End .....	16
Foxboro Cable .....	16
Shielded Twisted Pair Cable .....	17
Coil Drive Cable – Transmitter End .....	18
Flowtube Terminations .....	18
Signal Cable – Foxboro Cable.....	18
Coil Drive Cable.....	20

Cable Description and Terminal Designations .....	22
Wiring the Transmitter to the Flowtube .....	22
Wiring the Supply Power .....	25
Wiring the Transmitter Output .....	26
Output Circuits Power .....	26
Write Protect Switch .....	26
Digital Output Circuit .....	26
Internally Powered Analog Output Circuit .....	28
Externally Powered Analog Output Circuit .....	29
Pulse Output Circuit .....	31
Externally Powered .....	32
Internally Powered .....	33
Contact Input and Relay Output Circuits .....	33
Contact Inputs .....	33
Relay Outputs .....	34
<b>Index .....</b>	<b>35</b>

# Figures

1	Typical Transmitter Data Plate .....	8
2	Mounting Transmitter to a Surface .....	10
3	Mounting the Transmitter to a Vertical DN 50 or 2-in Pipe .....	11
4	Mounting Transmitter in a Panel .....	12
5	Wire Entrances and Conduit Connections .....	13
6	Conduit Hole Plug .....	14
7	Optional Cable Glands for Use in Nonconduit Installations .....	14
8	Access to Terminals .....	15
9	Preparing Foxboro Signal Cable for Connection to IMT96 Transmitter .....	17
10	Preparing Signal Cable for Connection to IMT96 Transmitter (Shielded Twisted Pair) .....	17
11	Preparing Coil Drive Cable for Connection to IMT96 Transmitter (Shielded Twisted Pair) .....	18
12	Preparing Foxboro Signal Cable Using Lug Terminals for Connection to Flowtube ....	19
13	Preparing Signal Cable for Connection to Flowtube Terminals (Shielded Twisted Pair)	20
14	Preparing Coil Drive Cable for Connection to Flowtube Terminals .....	21
15	Wiring of 2800 Series Flowtubes (Foxboro Multiconductor Signal Cable) .....	23
16	Wiring of 2800 Series Flowtubes (Shielded Twisted-Pair Signal Cable) .....	23
17	Wiring of IMT96 Transmitter (Foxboro Signal Cable) .....	24
18	Wiring of IMT96 Transmitter (Twisted Pair Signal Cable) .....	25
19	Output Loop Power DIP Switch Settings .....	26
20	Typical Digital Output Signal to an I/A Series System .....	27
21	Typical Internally Powered 4 to 20 mA Output Wiring .....	29
22	Supply Voltage and Loop Load Requirements for Externally Powered Analog Output Circuits .....	30
23	Typical Externally Powered 4 to 20 mA Output Wiring .....	31
24	Pulse Output Wiring .....	31
25	Contact Input and Relay Output Wiring .....	33

# Tables

1	Reference Documents .....	1
2	Standard Specifications .....	3
3	Operating Conditions .....	5
4	Process Fluid Conductivity and Cabling .....	6
5	Electrical Safety Specifications .....	7
6	Signal and Coil Drive Cable and Terminal Designations .....	22
7	Load Resistance Range to Maintain Low State Voltage = 1 Volt Maximum .....	32

# 1. Introduction

## Overview

The Model IMT96 MagEXPERT Flow Transmitters, together with the 2800 Series Flanged Magnetic Flowtubes, combine to form a magnetic flow measurement system that can be used on any conductive liquid or slurry, but especially on applications where significant process/fluid noise is present and/or process control is critical. The IMT96 uses the Invensys Process Systems (IPS) patented eX-Pulse coil excitation method to create a strong measurement signal that converts to a digital, analog, and pulse output proportional to flow rate.

## Reference Documents

*Table 1. Reference Documents*

Document	Document Description
DP 021-367	Dimensional Print - Model IMT96 MagEXPERT Flow Transmitter
MI 021-403	Model IMT96 MagEXPERT Flow Transmitter - Local Operation, Configuration, and Calibration
MI 021-404	Model IMT96 MagEXPERT Flow Transmitter - System Maintenance
MI 021-412	Retrofit instructions for Flowtubes Previously Connected to E96 or IMT25 Transmitters
MI 021-415	Model IMT96 - Operation, Configuration and Calibration using a HART Communicator
PL 008-747	Parts List - Model IMT96 MagEXPERT Flow Transmitter
TI 27-71f	Magnetic Flowtubes Material Selection Guide
TI 027-072	Electrical Conductivity of Process Liquids

## General Description

The IMT96 MagEXPERT Flow Transmitters, together with 2800 Series Magnetic Flowtubes, combine to form a magnetic flow measurement system that can be used on any conductive liquid or slurry.

The optimum flowtube for use with the IMT96 Transmitter is a 2800 Series Flowtube that has been calibrated for IMT96 use. The IMT96, however, can also be retrofitted for use with a 2800 Series Flowtube that has not been calibrated for IMT96 service. The accuracy, based on a recalculated flowtube meter factor, is slightly reduced. Refer to MI 021-412.

The IMT96 uses the IPS patented eX-Pulse coil excitation method to create its measurement signal. It is neither an ac transmitter nor is it a pulsed dc transmitter. It is similar to a pulsed dc transmitter in that it supplies power to the flowtube coils. This power is pulsed on/off to achieve zero stability (high precision). It is similar to a conventional ac transmitter in that the flow signal is integrated over the entire pulse cycle, speed of response is fast, and the flow signal strength is high due to higher coil current than conventional pulsed dc systems.

The transmitter comes with a FoxCom or HART communications protocol as specified. The digital output signal is used for flowmeters serving as a primary measuring device in a Digital control System (DCS) such as an I/A Series system. You can communicate with a FoxCom transmitter via an I/A Series workstation, PC-Based Configurator, or the optional local keypad/display. Communication with a HART transmitter is via a DCS system, a HART Communicator, or the optional local keypad/display. The 4 to 20 mA output signal is used with a suitable receiver to indicate, record, and/or control a variable. The signals are simultaneously available at a common pair of output terminals.

A pulse output is also available. The pulse output signal can be configured as a scaled pulse for totalization or frequency for flow rate output. Details of the output signals are given in the “Standard Specifications” on page 3.

The IMT96 Transmitter can either be mounted to a pipe (IMT96-P) or surface or panel (IMT96-S). It is available with or without an LCD display/keypad. Options for protective clear plastic window guard and/or an I/O access port are also available.

The keypad/display consists of a 32-alphanumeric character, 2-line back-lighted LCD display and a 5-button keypad. The display can indicate positive total, negative total, net total, net inventory, and flow rate in conventional flow units. A “+” or “-” indicator shows flow direction. This allows the transmitter to be used as a stand-alone unit and gives you complete operation and configuration capabilities.

The optional clear plastic guard protects the display and keypad during washdown operations to prevent inadvertent activation of the buttons by the washdown stream. However, the front panel is dusttight and weatherproof, as defined by IEC IP66, and provides the environmental and corrosion-resistant protection of NEMA Type 4X even without the guard.

The optional I/O access port is a circular recess in the front face of the instrument protected by a separate cover integrally connected to the front panel to prevent loss or misplacement. You can access the port by loosening a screw on the port cover. Inside the access port are two banana plug sockets. These sockets allow direct connection of the PC-Based Configurator or HART Communicator, when available. The I/O access port option permits access to terminals without opening the transmitter housing cover.

This instruction contains transmitter installation details. Refer to the Table 1 for a list of instructions for transmitter configuration, operation, calibration, maintenance, and other details.



# Standard Specifications

*Table 2. Standard Specifications*

Item	Specification									
<b>Operating Conditions</b>	See Table 3.									
<b>Electrical Output Signals</b>										
Digital Output	The IMT96 Transmitter with a FoxCom communications protocol digital signal communicates bidirectionally over the 4 to 20 mA output loop using an FSK (Frequency Shift Keying) technique.									
FoxCom Communication Protocol	In Analog Mode: Provides communication at 600 baud and provides an active 4 to 20 mA signal. The maximum cable length is 1800 m (6000 ft). In Digital Mode: Provides communication at 4800 baud with a maximum cable length of 600 m (2000 ft). The 4 to 20 mA signal is held constant at 10 mA.									
HART Communication Protocol	Provides communication at 1200 baud and provides an active 4 to 20 mA signal. The maximum cable length is 1800 m (6000 ft). <sup>(a)</sup>									
PC-based Configurator or HART Communicator Connections	The PC-based Configurator or HART Communicator must be connected across an impedance of at least 250 ohms. The total resistance between these devices and the transmitter must not exceed 350 ohms.									
4 to 20 mA Output	The current output is isolated. Exception: the current output and pulse output are <b>not</b> isolated from each other if they are both internally powered. The current output is also configurable to a 4 to 12 and 12 to 20 mA split range. Minimum current is 3.6 mA and maximum current is 22 mA.									
Pulse Output	This is a 2-wire transistor switch type output and is configurable as a scaled pulse or frequency output.									
Scaled Pulse Mode	<table border="1"> <thead> <tr> <th>Speed</th> <th>Pulse Width</th> <th>Max. Frequency</th> </tr> </thead> <tbody> <tr> <td>Slow</td> <td>50.0 ms</td> <td>10 Hz</td> </tr> <tr> <td>Medium</td> <td>5.0 ms</td> <td>100 Hz</td> </tr> </tbody> </table>	Speed	Pulse Width	Max. Frequency	Slow	50.0 ms	10 Hz	Medium	5.0 ms	100 Hz
Speed	Pulse Width	Max. Frequency								
Slow	50.0 ms	10 Hz								
Medium	5.0 ms	100 Hz								
Frequency Mode	Selectable: 0 to 1000, 2000, 5000, or 10000 Hz. Frequency signals below 3 Hz drop to 0 Hz. Square Wave, Voltage dependent on power supply.									
<b>Supply Voltage Requirements and External Loop Load Limitations</b>										
Digital Output	Power for the digital communications comes from the 4 to 20 mA analog loop power.									
4 to 20 mA Output	The loop power can be internal (supplied by the transmitter) or external (supplied by some other device in the loop).									
4 to 20 mA Output – Internally Powered	Output shares the same circuit reference as the pulse output, if pulse output is also internally powered. This circuit reference must only be grounded in one location. Maximum external load is 500 $\Omega$ (300 $\Omega$ if pulse output circuit is internally powered and in use).									
4 to 20 mA Output – Externally Powered	Refer to Figure 22 on page 30 for a graph of external supply voltage vs. output load resistance.									

**Table 2. Standard Specifications (Continued)**

<b>Item</b>	<b>Specification</b>
Pulse Output	The loop power can be internal (supplied by the transmitter) or external (supplied by some other device in the loop).
Pulse Output - Internally Powered	Pulse output shares the same circuit reference as the current output if the current output is also internally powered. This circuit reference can only be grounded in one location. Voltage: 24 V dc $\pm$ 15%. Current: 1 mA minimum; 80 mA maximum, short circuit protected.
Pulse Output - Externally Powered	5 to 42 V dc. Refer to Table 7 on page 32.
<b>Contact Inputs (2)</b>	Input is made with a current sinking device such as contact closure or transistor switch between IMT96 terminal block connections. The contact inputs share the same circuit reference, but are isolated from the solution ground. The circuit reference for current and/or pulse output is the same as contact inputs when internal power option is selected. Voltage: 25 V dc maximum Current: 15 mA maximum
<b>Contact Outputs (2)</b>	Two Type A (isolated) relay outputs. Voltage: 60 V dc maximum, 30 V ac rms maximum. Current: 3 A maximum resistive. Inductive loads can be driven with external surge absorbing devices installed across contact terminations.
<b>Power Consumption</b>	Less than 100 VA at reference voltage and frequency.
<b>Enclosure</b>	
Material	Light weight cast aluminum.
Finish	High-build epoxy paint.
Environmental Protection	The enclosure is dusttight and weatherproof as defined by IEC IP66 and provides the environmental and corrosion-resistant protection of NEMA Type 4X.
<b>Approximate Mass</b>	5.2 kg (11.5 lb)
<b>Flow Limits</b>	
Min. and Max. Upper Range (Flowmeter Capacity) Flow Rate Limits	Refer to applicable flowtube instruction documents. (See Table 1)
Low Flow Cut-Off	A low flow cut-off algorithm forces the pulse output, display, and digital measurement value to zero when the measurement signal falls below 0.01 m/s (0.033 ft/s). Note that there is no low flow cut-off with 4 to 20 mA current output.
<b>Calibration and Configuration</b>	The transmitter is easily scaled to the desired flow rate units and to the required upper range value. Refer to applicable reference documents for detailed instructions.
<b>Process Fluid Conductivity and Cabling</b>	See Table 4.
(a) Adhering to the requirements of HART physical layer implementation.	

*Table 3. Operating Conditions*

Transmitter Influence	Reference Operating Conditions	Normal Operating Condition Limits	Operative Limits	Transportation and Storage Limits
Ambient Temperature	23±2°C (73±3°F)	-20 and +55°C (-4 and +131°F)	-30 and +60°C (-22 and +140°F)	-40 and +85°C (-40 and +185°F)
Relative Humidity	50±10%	5 and 100%(a)	5 and 100%(a)	0 and 100%(a)
Power Input	120 or 240 V ac 60 Hz	Rated Voltage +10 and -15% ±5%	Rated Voltage +10 and -15% ±5%	
	230 V ac 50 Hz	±10% ±5%	±10% ±5%	
4 to 20 mA Output Supply Voltage External Load	24 V dc 250 Ω	(Refer to Figure 22) 10 and 50 V dc 0 and 1950 Ω	(Refer to Figure 22) 10 and 50 V dc 0 and 1950 Ω	
Pulse Output Supply Voltage External Load	24 V dc 480 Ω	5 and 42 V dc 62.5 and 5000 Ω	5 and 42 V dc 62.5 and 5000 Ω	
Vibration	Negligible	0 and 5 m/s <sup>2</sup> (0 and 0.5 g) from 5 to 500 Hz	5 m/s <sup>2</sup> (0.5 g) up to 500 Hz	See Note (b)
Pollution Degree	--	2	--	--
Installation Category (Overvoltage Category)	--	II	--	--

(a) Relative humidity limits apply only with transmitter covers properly installed.

(b) During transportation, the packaged transmitter can withstand normal handling and shipping conditions without damage.

### Maximum Cable Length

The maximum allowable cable length between the flowtube and transmitter is a function of the cable type, process fluid conductivity, and whether the cables are in the same or separate conduits. For cable lengths greater than 150 m (500 feet) and conductivities less than 20  $\mu\text{S}/\text{cm}$ , the system accuracy is affected.

*Table 4. Process Fluid Conductivity and Cabling*

Fluid Conductivity	Cable Length	Signal and Coil Drive Cables
>20 $\mu\text{S}/\text{cm}$	<150 m (500 ft)	Signal and coil drive cables can be in the same conduit. The signal cable can be either Foxboro cable <sup>(a)</sup> or good quality 14 to 18 AWG twisted shielded pair <sup>(b)</sup> cable. The coil wiring should be 14 AWG twisted shielded pair. <sup>(c,d)</sup>
	150 to 300 m (500 to 1000 ft)	Signal and coil drive cables can be in the same conduit. The signal cable can be either Foxboro cable <sup>(a)</sup> or good quality 14 to 18 AWG twisted shielded pair <sup>(b)</sup> cable. For these cable lengths, there is an additional error per every 30 m (100 ft) in excess of 150 m (500 ft): 0.2% when using Foxboro cable <sup>(a)</sup> . 0.4% when using 14 to 18 AWG twisted shielded pair <sup>(b)</sup> . The coil cable must be good quality 14 AWG twisted shielded pair <sup>(c)</sup> .
2 to 20 $\mu\text{S}/\text{cm}$	<150 m (500 ft)	Signal and coil drive cables should be in separate conduits. For fluid conductivity in this range, Foxboro signal cable <sup>(a)</sup> must be used. For these conductivities there is an additional error in percent equal to 4 divided by the conductivity in $\mu\text{S}/\text{cm}$ ; for example, for a conductivity of 12 $\mu\text{S}/\text{cm}$ the additional error would be 0.3%. The coil wiring should be 14 AWG twisted shielded pair. <sup>(c,d)</sup>
	150 to 300 m (500 to 1000 ft)	Signal and coil drive cables must be in separate conduits. For fluid conductivity in this range, Foxboro signal cable <sup>(a)</sup> must be used. For these conductivities there is an additional error in percent equal to 4 divided by the conductivity in $\mu\text{S}/\text{cm}$ ; for example, for a conductivity of 12 $\mu\text{S}/\text{cm}$ the additional error would be 0.3%. For these cable lengths, there is also an additional 0.2% error per every 30 m (100 ft) in excess of 150 m (500 ft). The coil cable must be 14 AWG twisted shielded pair <sup>(c)</sup> .

(a) Foxboro Part No. R0101ZS (feet) or B4077TE or B4017TE (meters).

(b) Such as Belden 8760 or 9318, Alpha 5610/1801, 5611/1801.

(c) Such as Belden 8720 series or Alpha 5616 series.

(d) 14 AWG 2-core (2-conductor) cable or two separate 14 AWG wires can also be used.

16 AWG can be used for cables shorter than 90 m (300 ft).

18 AWG can be used for cables shorter than 45 m (150 ft).

# Electrical Safety Specifications

Refer to Table 5 for electrical classification, application conditions, and electrical safety design code. The single-character electrical safety design code is included in the model number listed on the transmitter data plate.

*Table 5. Electrical Safety Specifications*

Testing Laboratory, Types of Protection, and Area Classification	Application Conditions	Electrical Safety Design Code
CSA Class I, Division 2, Groups A, B, C, and D; Class II, Division 2, Groups F and G; Class III hazardous locations.	Temperature Class T4.	L
FM nonincendive, Class I, II, and III, Division 2, Groups A, B, C, D, F, and G, hazardous locations.	Temperature Class T4.	N
Testing laboratory approval or certification not required.	–	Z

**— NOTE —**

The IMT96 Transmitter has been designed to meet the electrical safety descriptions listed in Table 5. For detailed information or status of testing laboratory approvals or certifications, contact IPS.

# Transmitter Identification

The transmitter can be identified by a data plate located on the front of the instrument. A typical data plate is shown in Figure 1. Refer to the applicable flowtube instructions for information regarding flowtube-specific data plates.

<b>I/A Series<sup>®</sup> MagEXPERT FLOW TRANSMITTER</b>	
<b>MODEL NO.</b>	
<b>ORIGIN</b>	ST.
<b>SUPPLY PWR</b>	110 VA MAX.
<b>FREQUENCY</b>	<b>PULSE OUT</b>
<b>OUTPUT</b>	
<b>REF. NO.</b>	
<b>TUBE REF. NO.</b>	
<b>CONTACT OUT.</b>	60 Vdc max. 30 Vac rms max. 3 A max. resistive
<b>CONTACT IN.</b>	25 Vdc max. 15 mA max.
<b>CUST. DATA</b>	Ver. 1 Software



**WARNING:** EXPLOSIVE HAZARD DO NOT DISCONNECT EQUIPMENT UNLESS POWER HAS BEEN SWITCHED OFF OR THE AREA IS KNOWN TO BE NON-HAZARDOUS

**WARNING:** EXPLOSIVE HAZARD - SUBSTITUTION OF COMPONENTS MAY IMPAIR SUITABILITY FOR CLASS 1, DIVISION 2

**AVERTISSEMENT:** RISQUE D'EXPLOSION AVANT DE DEBRANCHER L'EQUIPEMENT. COUPER LE COURANT OU ASSURER QUE L'EMPLACEMENT EST DESIGNÉ NON DANGEREUX.

**AVERTISSEMENT:** RISQUE D'EXPLOSION - LA SUBSTITUTION DE COMPOSANTS PEUT RENDRE CE MATERIEL INACCEPTABLE POUR LES EMBLEMES DE CLASSE 1, DIV 2

**FOXBORO<sup>®</sup>**  
THE FOXBORO CO.,  
 FOXBORO, MA, U.S.A.  
 This product and its components are protected by U. S. Patent No. 5,641,914 and other Foreign Patents Pending.  
 CL I, DIV 2, GP A, B, C  
 D; CL II, DIV 2, GP F & G;  
 CLASS III, DIVISION 2  
 HAZARDOUS LOCATIONS  
 T4 @ 60 C MAX AMBIENT  
 ENCLOSURE 1X

  APPROVED



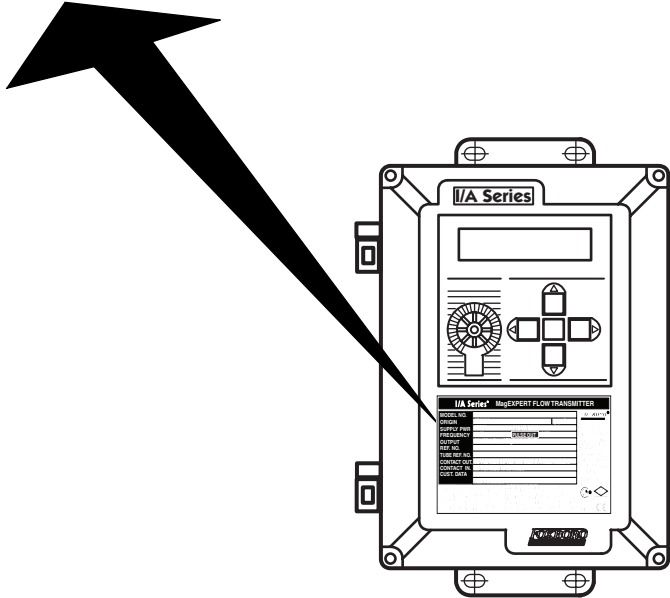

Figure 1. Typical Transmitter Data Plate

---

**— NOTE —**

Internal or external power of current and pulse output is set at the factory as shown on your data plate. This can be changed by DIP switches in your transmitter. Refer to Figure 19.

---

## 2. *Mounting*

### Unpacking and Handling Procedure

After removing the transmitter from its shipping carton, inspect it for visible damage. If any damage is observed, notify the carrier immediately and request an inspection report. Obtain a signed copy of the report from the carrier.

For detailed information regarding flowtube handling, refer to the applicable flowtube instruction.

### Transmitter Dimensions

For transmitter dimensions and space requirements, refer to DP 021-367.

### Transmitter Door

—  **CAUTION** —

---

The electronics contained within the transmitter door are matched to the electronics in the transmitter case. Do **not** exchange the doors of like instruments.

---

# Transmitter Mounting

## Surface Mounting

The transmitter can be mounted against a surface as shown in Figure 2. Mount it to the surface using the four mounting holes in the enclosure mounting flanges and the required mounting hardware (supplied by user).

— **NOTE** —

If you want to convert from surface mounting to pipe mounting of the transmitter, IPS can provide parts to implement this conversion. Refer to PL 008-747 for the applicable parts and part numbers required.

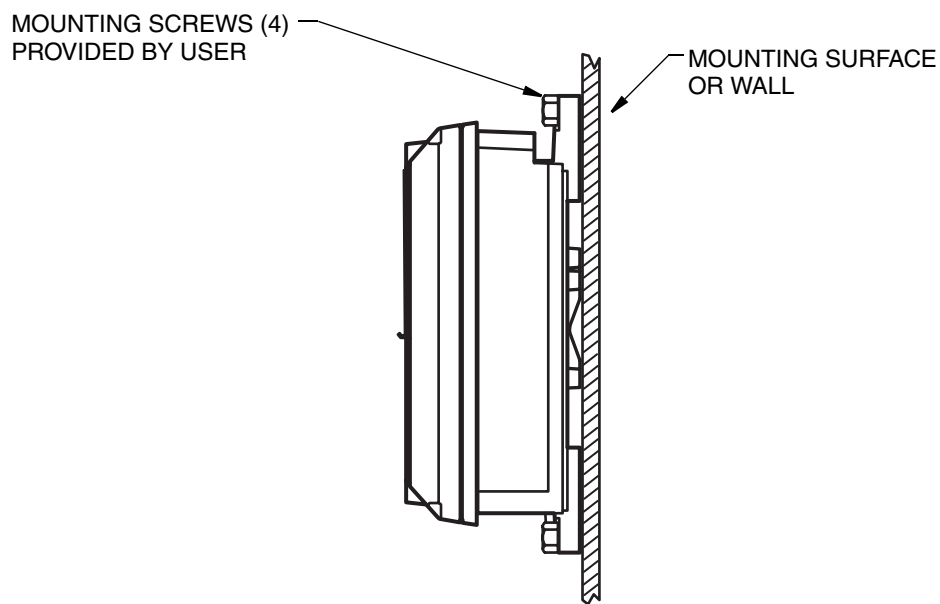

*Figure 2. Mounting Transmitter to a Surface*



## Pipe Mounting

The transmitter can be mounted to a DN 50 or 2-in vertical pipe as shown in Figure 3.

1. Gather the U-bolts, flat washers, lockwashers, and nuts provided and keep them in a convenient place in preparation for use during installation.
2. Hold and press the transmitter against the pipe while installing one U-bolt onto the pipe and into the transmitter mounting flange.
3. Add the plain washer and lockwasher, and nuts, and then hand-tighten the two nuts.
4. Repeat Steps 3 and 4 for the second U-bolt and then tighten all nuts securely.

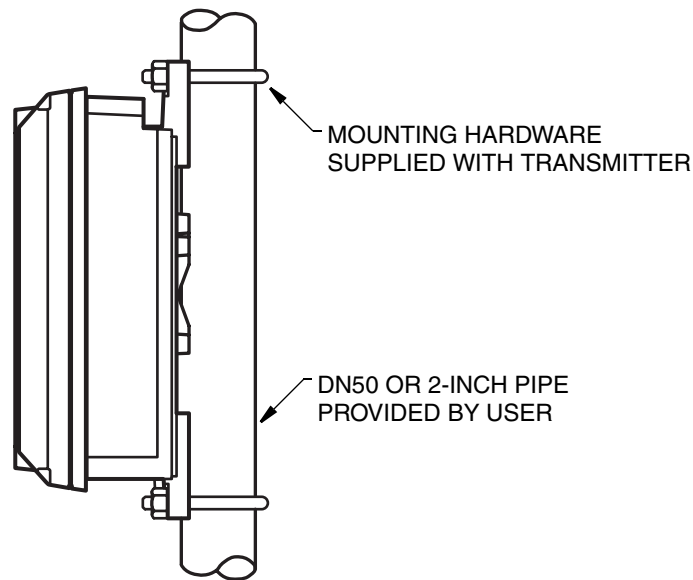
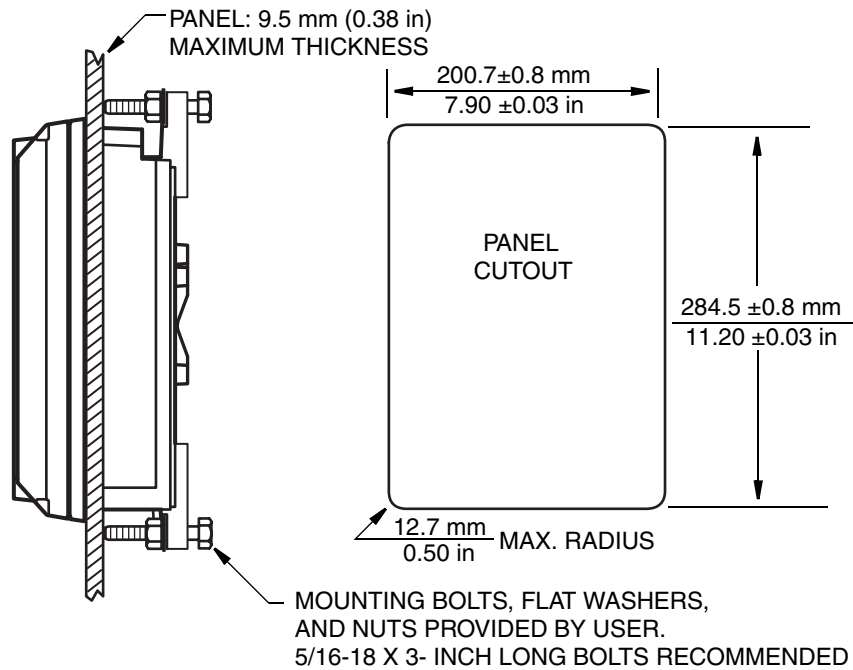

*Figure 3. Mounting the Transmitter to a Vertical DN 50 or 2-in Pipe*

## Panel Mounting

The transmitter can be panel mounted as shown in Figure 4.

1. Cut out the panel to the size shown.
2. Insert the transmitter into the panel from the front of the panel by tipping the top of the transmitter into the panel opening and then swinging in the bottom of the transmitter.
3. Secure with appropriate bolts, flat washers and nuts (supplied by user).



*Figure 4. Mounting Transmitter in a Panel*

# 3. Wiring

---

**! WARNING**

To maintain IEC IP66 and NEMA Type 4X protection, the unused conduit openings must be plugged. In addition, the housing covers must be installed and fastened in place with the four captive screws provided to a torque of 27 to 34 N•m (20 to 25 lb•in).

---

---

**! CAUTION**

The electronics contained within the transmitter door and the electronics in the transmitter case are calibrated as a matched pair. Do **not** exchange the doors of like instruments.

---

## Wire Entrances and Conduit Connections

Four 22 mm (0.866 in) diameter conduit holes are located on the bottom of the transmitter (see Figure 5). The holes are sized to accommodate PG 13.5 or 1/2 NPT conduit connectors (provided by user). If conduit is used, separate runs are recommended for input signal, output signal, flowtube coil drive wires and ac supply. To maintain IEC IP66 and NEMA 4X moisture, dust, and corrosion protection, use approved watertight conduit fittings and plug all unused holes with the plug, seal ring and nut shown in Figure 6. IPS also offers optional cable glands for nonconduit applications (see Figure 7).

---

**! CAUTION**

The nonthreaded shipping plugs do **not** meet IEC IP66 and NEMA 4X requirements. Failure to use proper fittings and plugs voids your warranty.

---

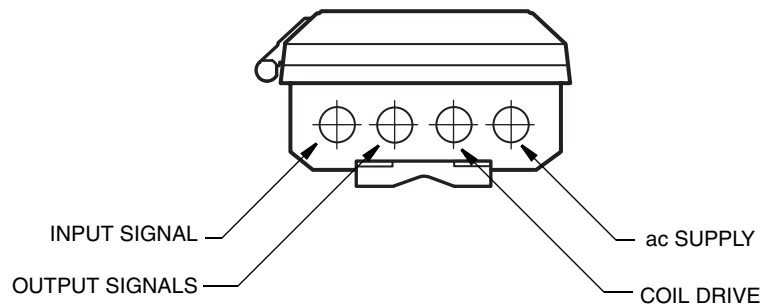

NOTE: RECOMMENDED USE OF CONDUIT HOLES SHOWN

*Figure 5. Wire Entrances and Conduit Connections*

## Conduit Hole Plugs

Conduit hole plugs are used to provide a raintight sealing of unused wire entrances.

**CAUTION**  
 Plug L0123CA must be torqued to 1.2 - 1.6 N•m (11-14 lb•in) for proper sealing.

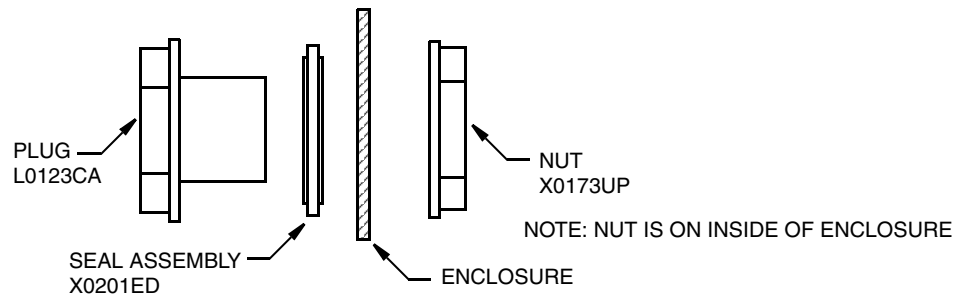

*Figure 6. Conduit Hole Plug*

## Optional Cable Glands for Nonconduit Applications

Optional cable glands are used in nonconduit applications to provide a raintight, strain relieved entrance for 7 to 12 mm (0.27 to 0.48 in) diameter cable. The body and the seal nut are nylon; the compression gland is neoprene. See Figure 7.

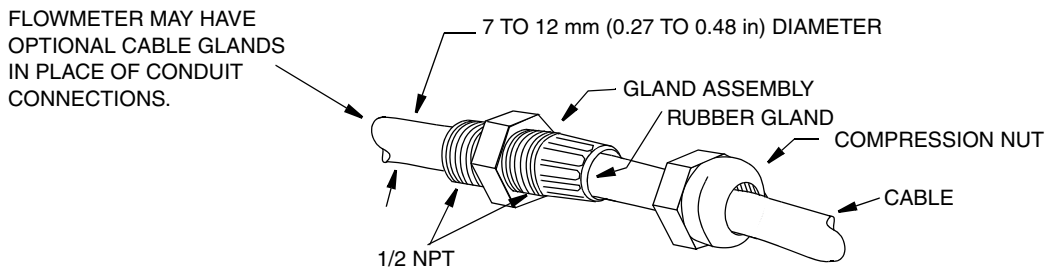

*Figure 7. Optional Cable Glands for Use in Nonconduit Installations*

## Access to Terminals

For access to terminals inside the transmitter, unscrew the four captive screws on the corners of the cover of the enclosure and swing open the door. For access to the terminals inside the flowtube, remove the six captive screws on the flowtube terminations cover. See Figure 8.

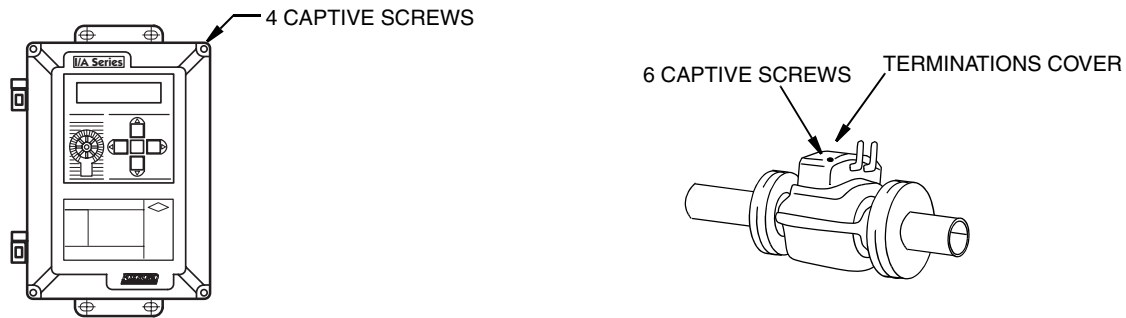

*Figure 8. Access to Terminals*



### CAUTION

To maintain an IEC IP65 and NEMA 4X rating, resecure the captive screws to a torque of 27 to 34 N•m (20 to 25 lb•in)

---

## Wiring Flowtube to Transmitter



### CAUTION

90°C wire is required in installations that exceed 40°C ambient.

---

## Recommended Wire Specifications

### Signal Wires

#### Foxboro Cable

- ◆ Two core, multiscreened (multiconductor, multishielded) cable, Foxboro Part No. R0101ZS (feet) or B4017TE (meters).

#### Twisted Shielded Pair Cable

- ◆ Good quality 18 AWG twisted shielded pair such as Beldon 8760, or Alpha 5610 or 5611.

---

#### NOTE

Cable type and length may be limited due to fluid conductivity. Refer to Table 4.

---

## Coil Drive Wires

- ◆ 14 AWG twisted shielded pair (such as Beldon 8720 or Alpha 5616).
- ◆ 14 AWG 2-core (2-conductor) cable
- ◆ Two separate 14 AWG wires.

---

**— NOTE**

---

The gauge of the coil drive wires can be lighter for short cable runs:

16 AWG if shorter than 90 m (300 ft)

18 AWG if shorter than 45 m (150 ft).

---

## Wire Preparation

### *Signal Cable – Transmitter End*

#### **Foxboro Cable**

Use this procedure to prepare the multicore (multiconductor) signal cable for connection to the transmitter terminals. Refer to Figure 9 for this procedure.

1. Strip back outer jacket and foil shield as shown. Cut outer shield lead flush with edge of jacket. (This shield should end in the transmitter housing without making electrical contact.)
2. Strip back inner jacket and foil shield as shown. Do **not** cut inner shield lead.
3. Strip back lead jackets as shown. Do not cut shield leads.
4. Strip insulation from white and black leads to be used with the special lugs (Foxboro Part No. K0123CP) supplied with the flowtube.

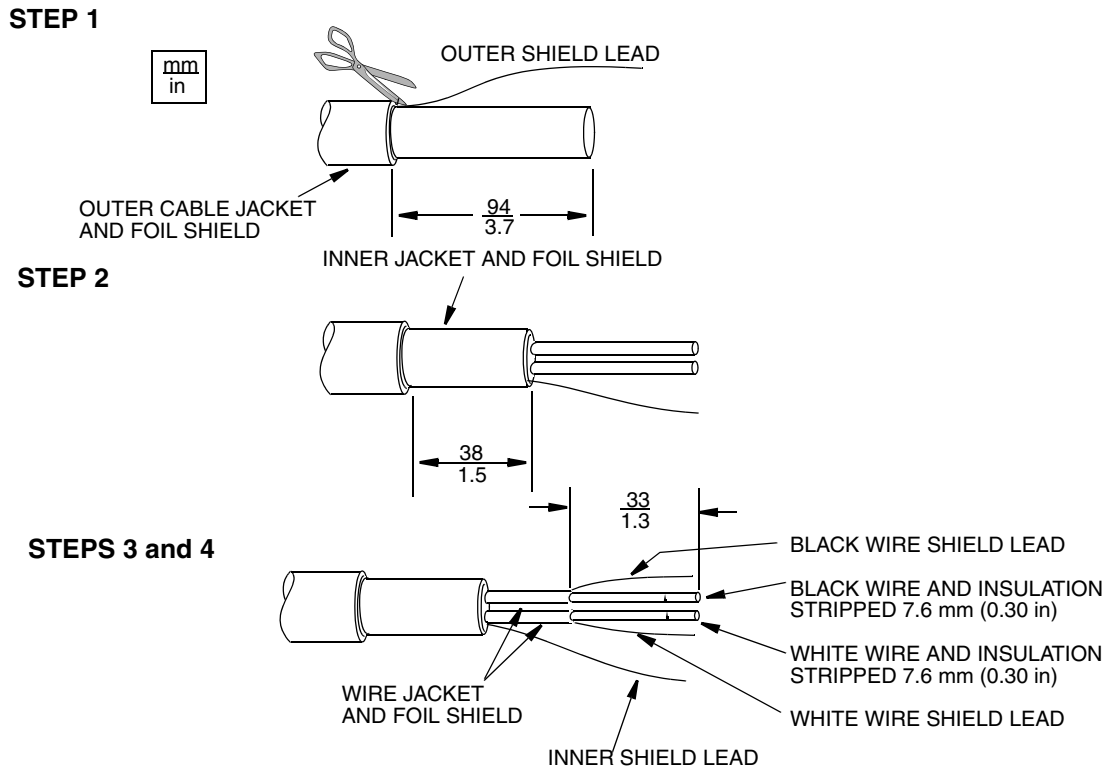

Figure 9. Preparing Foxboro Signal Cable for Connection to IMT96 Transmitter

### Shielded Twisted Pair Cable

Use this procedure to prepare the shielded twisted pair signal cable for connection to the transmitter terminals. Refer to Figure 10 for this procedure.

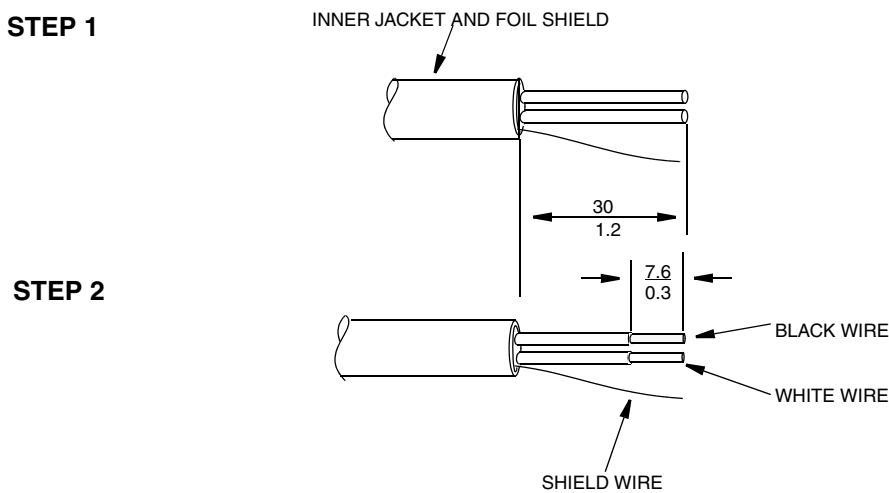
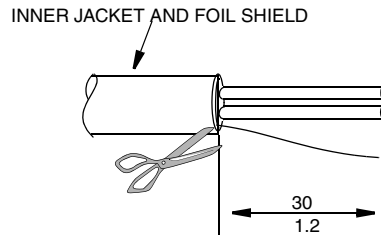

Figure 10. Preparing Signal Cable for Connection to IMT96 Transmitter (Shielded Twisted Pair)

## Coil Drive Cable – Transmitter End

Use this procedure to prepare the shielded twisted pair coil drive cable for connection to the transmitter terminals.

### STEP 1



### STEP 2

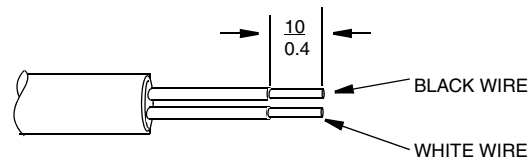

*Figure 11. Preparing Coil Drive Cable for Connection to IMT96 Transmitter (Shielded Twisted Pair)*

## Flowtube Terminations

### Signal Cable – Foxboro Cable

Use this procedure to prepare the multicore (multiconductor) signal cable (Foxboro Part No. R0101ZS or B4017TE) for connection to the flowtube terminals. Refer to Figure 12 for this procedure.

1. Strip back outer jacket and foil shield of cable as shown. Do not cut outer shield lead.
2. Strip back inner jacket and foil shield as shown. Do not cut inner shield lead.
3. Strip back lead jackets and foil shields as shown. Do not cut shield leads.
4. Strip insulation from black and white leads as shown.
5. Connect lug terminals to leads as shown.

---

#### — NOTE —

Lug terminals supplied with the flowtube (Foxboro Part No. K0123CP) are necessary to make good connections. The terminals can be soldered to the wires or used to retain the wires under the screws.

---



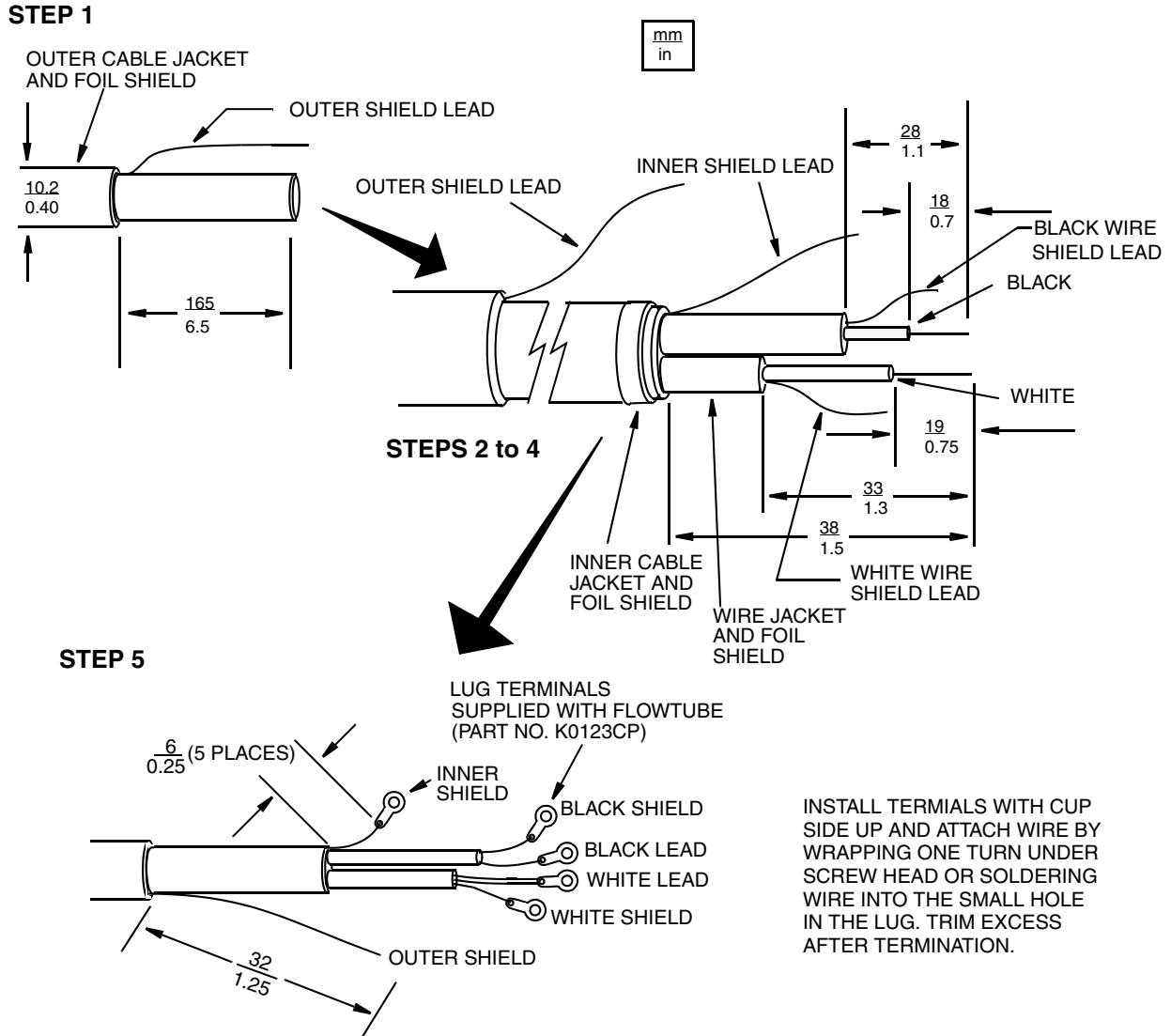
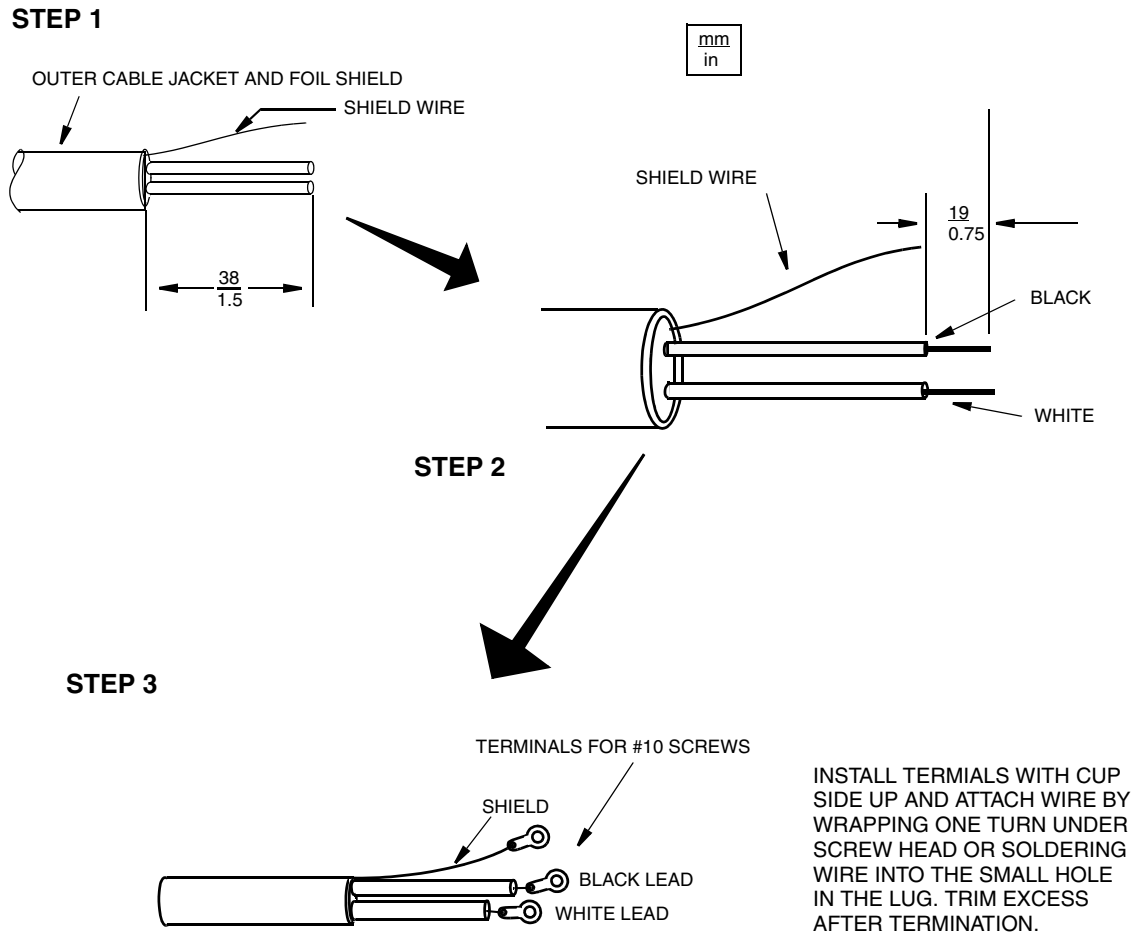

Figure 12. Preparing Foxboro Signal Cable Using Lug Terminals for Connection to Flowtube

Use this procedure to prepare the shielded twisted pair cable for connection to the flowtube terminals. Refer to Figure 13 for the procedure.



*Figure 13. Preparing Signal Cable for Connection to Flowtube Terminals (Shielded Twisted Pair)*

### Coil Drive Cable

Use this procedure to prepare the shielded twisted pair coil drive cable for connection to the flowtube terminals. Refer to Figure 14 for the procedure.

1. Strip back outer jacket and foil shield of cable as shown. Do not cut outer shield wire.
2. Strip insulation from black and white leads as shown.
3. If connections to terminal lugs are desired, connect lugs (supplied by user) to leads as shown.

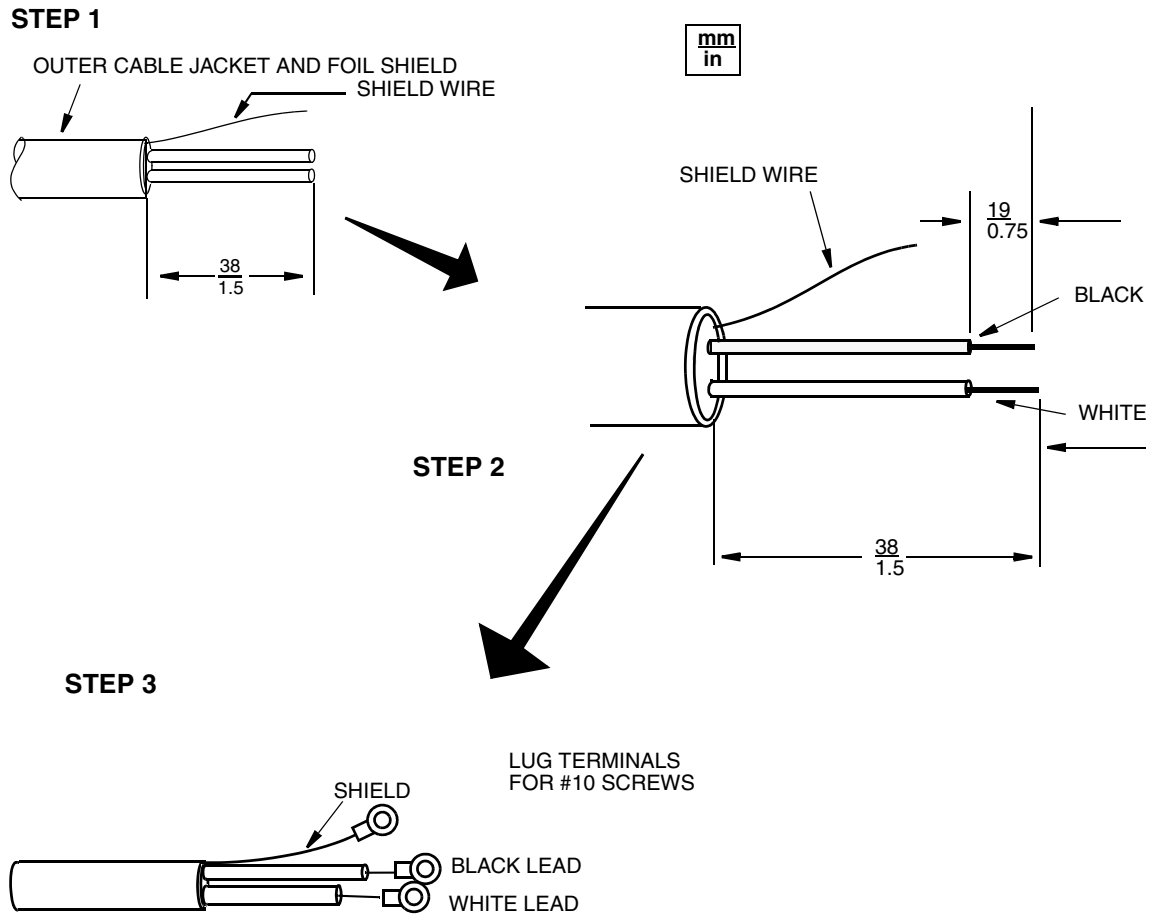

Figure 14. Preparing Coil Drive Cable for Connection to Flowtube Terminals

## Cable Description and Terminal Designations

Table 6 lists the signal cable and coil drive cable designations and the terminal designations in the transmitter and flowtube.

*Table 6. Signal and Coil Drive Cable and Terminal Designations*

Flowtube Terminals <sup>(a)</sup>	Signal and Coil Drive Cable	Transmitter Terminal Number <sup>(b)</sup>
W	White Signal — W (c)	2
SH	White Shield — SH <sub>W</sub>	1
INNER SHLD	Solution Ground — Inner Shield Lead (c)	3
SH	Black Shield — SH <sub>B</sub>	5
B	Black Signal — B (c)	4
OUTER SHLD	Outer Shield Lead	--
1	Coil Drive 1	Coil 1
2	Coil Drive 2	Coil 2

(a) Flowtube terminals are shown in Figures 15 and 16.

(b) Transmitter terminals are shown in Figures 17 and 19.

(c) These terminals are used with all cables listed in Table 5 on page 7. The other terminals are used only with Foxboro signal cable (PN R0101ZS or B4017TE).

## Wiring the Transmitter to the Flowtube

1. Remove the cover from the flowtube. See Figure 8.
2. Open the door of the transmitter.
3. Run the coil-drive and signal cables through the conduits or optional cable glands, as applicable.
4. Connect the signal wires to the flowtube output terminals as shown in Figures 15 and 16.
5. In the flowtube, clamp the signal cable over its inner jacket with the cable clamp as shown in Figures 15 and 16.
6. If the flowtube has optional cable glands, turn the compression nut (shown in Figure 7) until the rubber gland is snug around the signal cable.
7. Remove the protective cover from the coil-drive terminals.
8. If the “direction-of-flow” arrow on the flowtube is pointing **downstream**, connect the coil-drive wires from transmitter Coil 1 and 2 to Flowtube 1 and 2, respectively. If the arrow is pointing **upstream**, connect transmitter Coil 1 and 2 to Flowtube 2 and 1, respectively.
9. Reinstall the protective cover over the flowtube coil-drive terminals.
10. Reinstall the terminations cover on the flowtube.

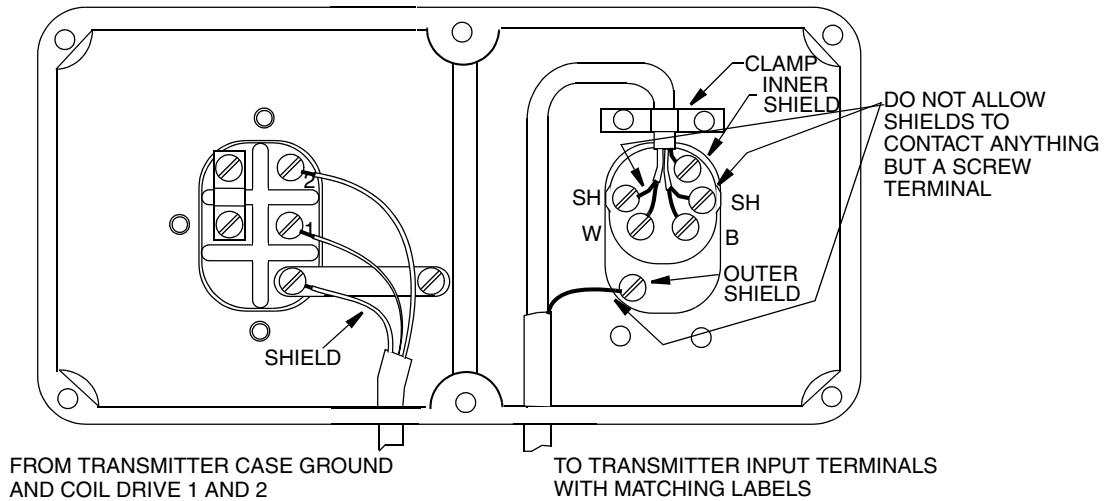

*Figure 15. Wiring of 2800 Series Flowtubes (Foxboro Multiconductor Signal Cable)*

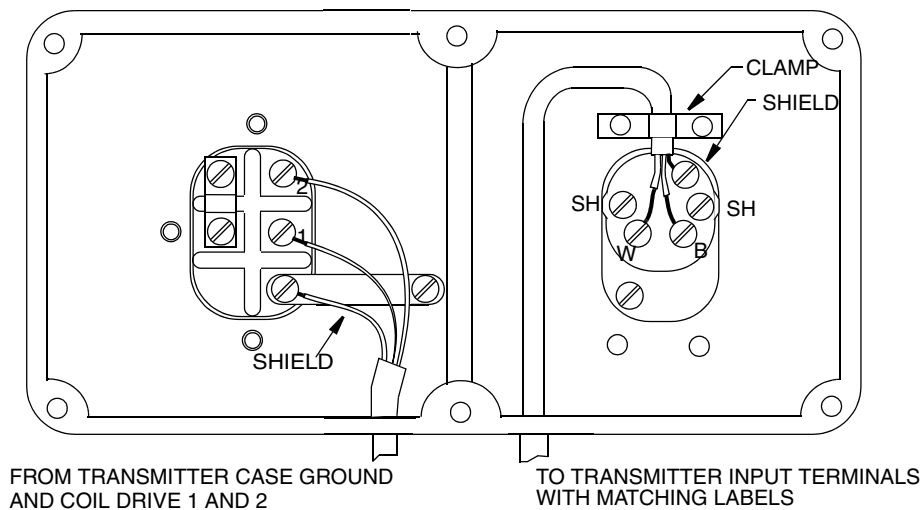

*Figure 16. Wiring of 2800 Series Flowtubes (Shielded Twisted-Pair Signal Cable)*

11. Connect the signal wires from the flowtube to the transmitter signal terminals as shown in Figure 17 and Table 6.
12. Connect the coil-drive wires to the transmitter coil terminals as shown in Figure 17. Tighten the optional gland compression nuts, if applicable.

**— NOTE —**

If twisted shielded pair coil drive wire is used, connect the shield to the flowtube housing only. Do **not** connect the shield to the transmitter.

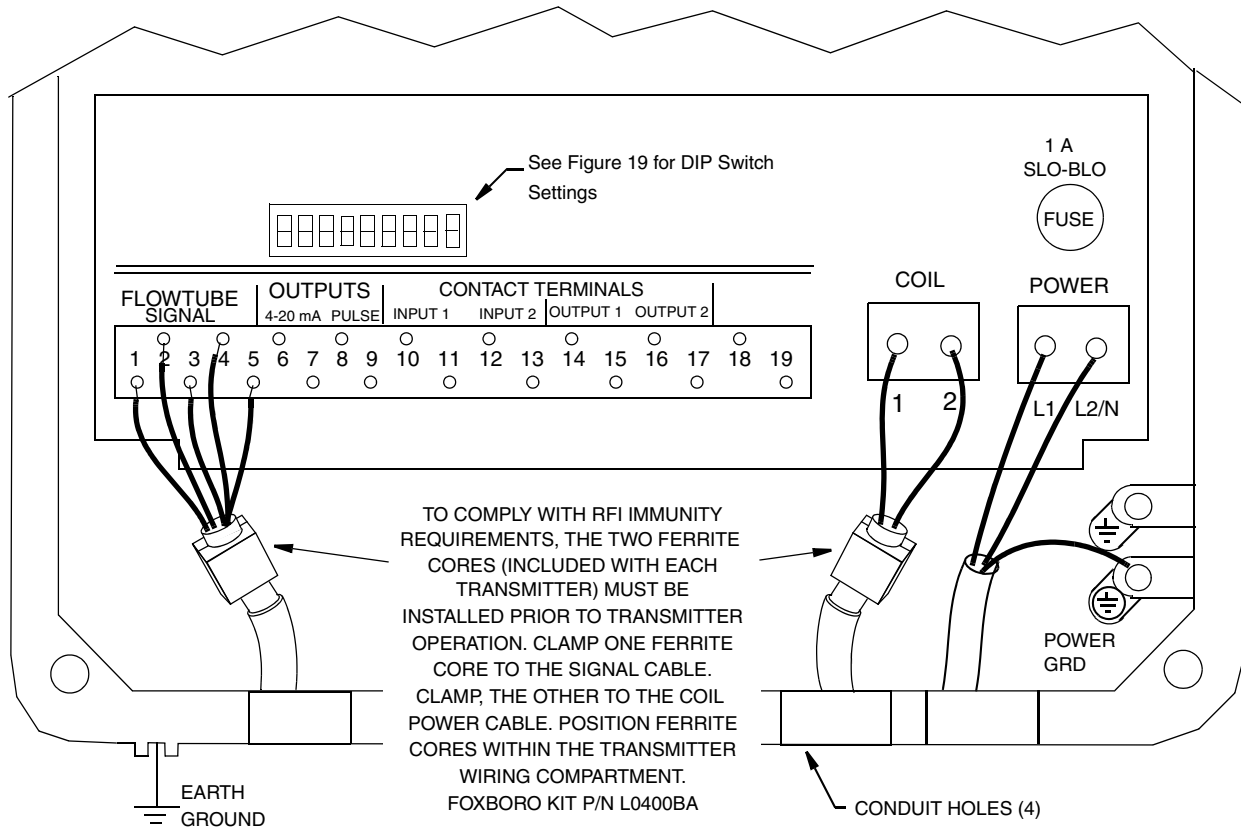
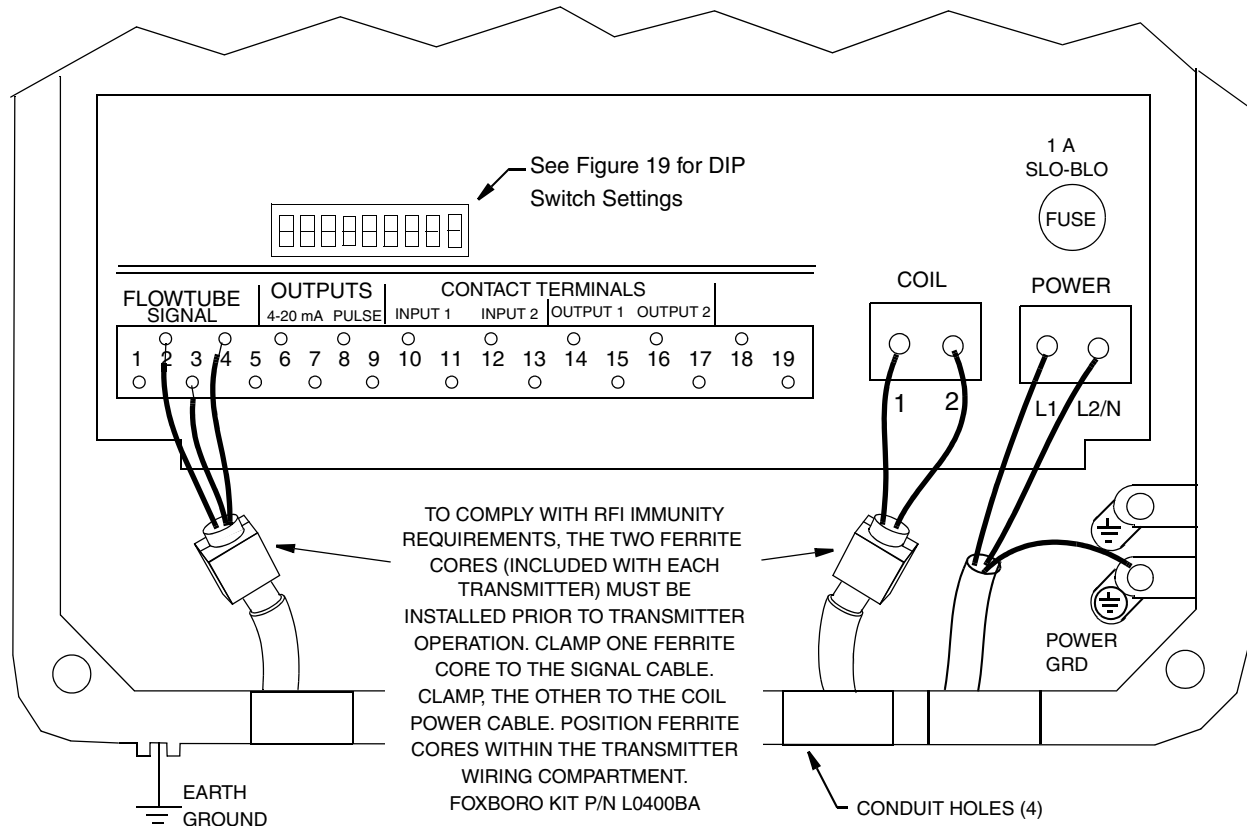

Figure 17. Wiring of IMT96 Transmitter (Foxboro Signal Cable)



*Figure 18. Wiring of IMT96 Transmitter (Twisted Pair Signal Cable)*

**— NOTE**

Transmitter case must be grounded in accordance with local practice. The locations of the ground terminals are shown in Figures 17 and 18.

## Wiring the Supply Power

**— NOTE**

Local agency requirements take precedence for supply power wiring and grounding. If no grounded neutral wire is available, connect protective ground to plant safety ground.

1. Check the data plate on the front of the transmitter to ascertain the correct supply power.
2. Run the power cable through the conduit or optional cable gland, as applicable. The recommended cable is 3-core (3-conductor) 2.50 mm<sup>2</sup> (14 AWG) or correct type and size in conformance with local wiring practice.
3. Connect the power leads to Terminal L1 and L2/N. Connect the ground wire to the Power Ground terminal.
4. To meet CE directives and the requirements of IEC 1000, connect the ground terminal on outside bottom of case to earth (ground).

## Wiring the Transmitter Output

### Output Circuits Power

Internal or external power for the IMT96 output signals is switch selectable. The switches have been factory set as defined by the model code of the transmitter but the setting can be changed. There is a group of nine switches that control internal or external power and the write protect feature (see Figures 17 or 18). The first four of these set the analog and digital loop power. The second group of four control the pulse loop output power. A ninth switch controls the write protect function. Power to the transmitter must be off when changing switch settings and the switches must be set to one of the patterns shown in Figure 19.

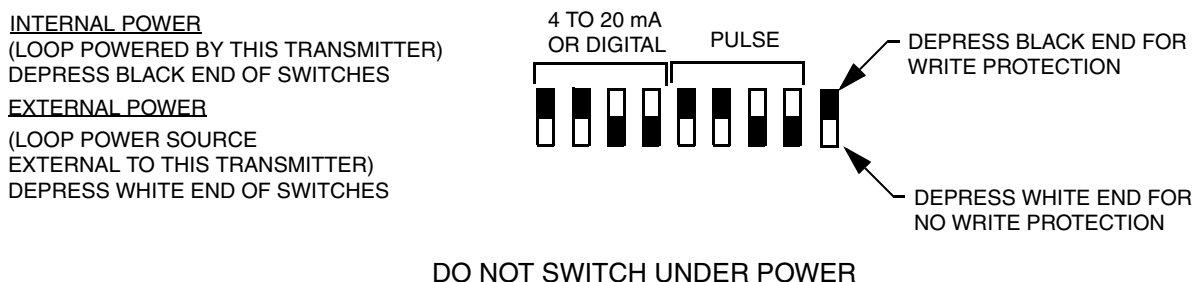

*Figure 19. Output Loop Power DIP Switch Settings*

### Write Protect Switch

The write protection DIP switch allows or prevents anyone from changing the configuration of the transmitter or resetting the totalizer. This feature is usually used in custody transfer applications or when, for any other reason, you want to ensure that the configuration and or totals are not changed. Refer to Figure 19 for switch position. The switch usually has the white end depressed (factory default position) which disables this feature. Depressing the black end of the switch engages the protection.

**— NOTE —**

A change in the write protect switch position does not take effect until power is turned off and on again.

### Digital Output Circuit

The transmitter digital output signal wiring connects to an I/A Series system. The output signal is superimposed on the 4 to 20 mA (loop) lines. This procedure identifies only transmitter wire terminations to the system. For other system wiring details, refer to the “Installation” instructions in the documentation provided with the I/A Series system or other DCS. The maximum length of field wire is 600 m (2000 ft). Signal output power is supplied by the FBM Input Module. Typical digital output signal wiring is shown in Figure 20.



**— NOTE —**

1. Make sure that the device name is the same as the letterbug used for that channel in your I/A Series system before installation. Note that the letterbug is case sensitive; use correct upper/lower-case letters.
2. When internally powered, the analog/digital, pulse output, and contact input circuits share the same circuit reference. They are isolated from other circuits but not from each other.

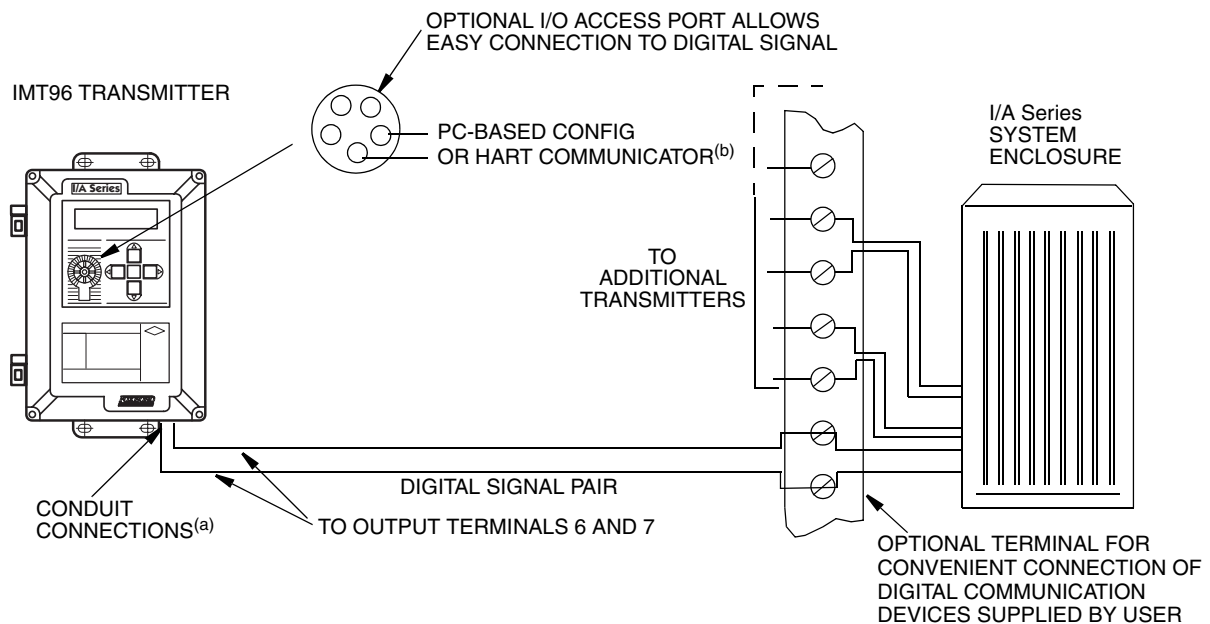

(a) RUN CONDUIT DOWN TO AVOID BUILDUP OF MOISTURE IN TERMINALS COMPARTMENT. PLUG ANY UNUSED CONDUIT CONNECTION.

(b) A PC-BASED CONFIGURATOR OR HART COMMUNICATOR CAN BE CONNECTED ANYWHERE BETWEEN THE TRANSMITTER FIELD TERMINALS AND THE EXTERNAL LOAD OR TO OPTIONAL I/O PORT.

*Figure 20. Typical Digital Output Signal to an I/A Series System*

1. Run signal wires (0.50 mm<sup>2</sup> or 20 AWG, typical) through the predetermined conduit connection on the transmitter. Use twisted-pair wire to protect the digital output and/or remote communications from electrical noise. Shielded cable is required in some locations.

**— NOTE —**

Do not run signal wires in the same conduit as mains (ac power) wires.

2. If shielded cable is used, ground the shield at the field enclosure **only**. Do not ground the shield at the transmitter.

**— ⚠ CAUTION —**

To avoid errors resulting from ground loops or the possibility of short-circuiting groups of instruments in a loop, there should be only one ground in a loop.

3. The PC-based Configurator or HART Communicator can be connected to the signal wires at the transmitter terminals through the optional I/O port (see Figure 20) or

other convenient locations in the loop (subject to certain restrictions). If desired, connect terminal strips at convenient locations (see Figure 20). For example, to communicate with several transmitters from a single location, connect each pair of signal wires to a separate pair of terminals. The PC-based Configurator or HART Communicator can then be easily disconnected from one loop and connected to another.

4. The location of terminal blocks in the I/A Series system enclosure depends both on the type of enclosure purchased and on the location of the transmitter input module inside the enclosure. To determine the terminal-block location for a particular system, refer to the “Installation” instructions in the loadable documentation provided with the I/A Series system.
5. To connect the transmitter signal wires to the I/A Series system, refer to applicable I/A Series system instructions. Note that the type of wire terminations used depends on the type of system enclosure purchased.

## Internally Powered Analog Output Circuit

Typical internally powered 4 to 20 mA output wiring is shown in Figure 21. Note that the maximum external load is 500  $\Omega$  (or 300  $\Omega$  if pulse output circuit is internally powered and in use). Also, a minimum 250  $\Omega$  load is required if connecting a PC-based Configurator or HART Communicator to the signal wires.

---

### — NOTE —

1. Internal power is set by DIP switches. Refer to Figure 19 and to verify setting or to change to external power.
  2. When internally powered, the analog/digital, pulse output, and contact input circuits share the same circuit reference. They are isolated from other circuits but not from each other.
  3. Grounding the loop at pin 6 is recommended but not required. If shielded wire is used for this signal, terminate the shield at pin 6.
  4. Grounding the loop at pin 6 is **required** if the pulse output is also internally powered, in use, and the selected Rate Max Freq is 5000 Hz or 10,000 Hz.
  5. Polarity is important when wiring and switching from internal power to external power and vice versa. See Figures 21 and 23.
-

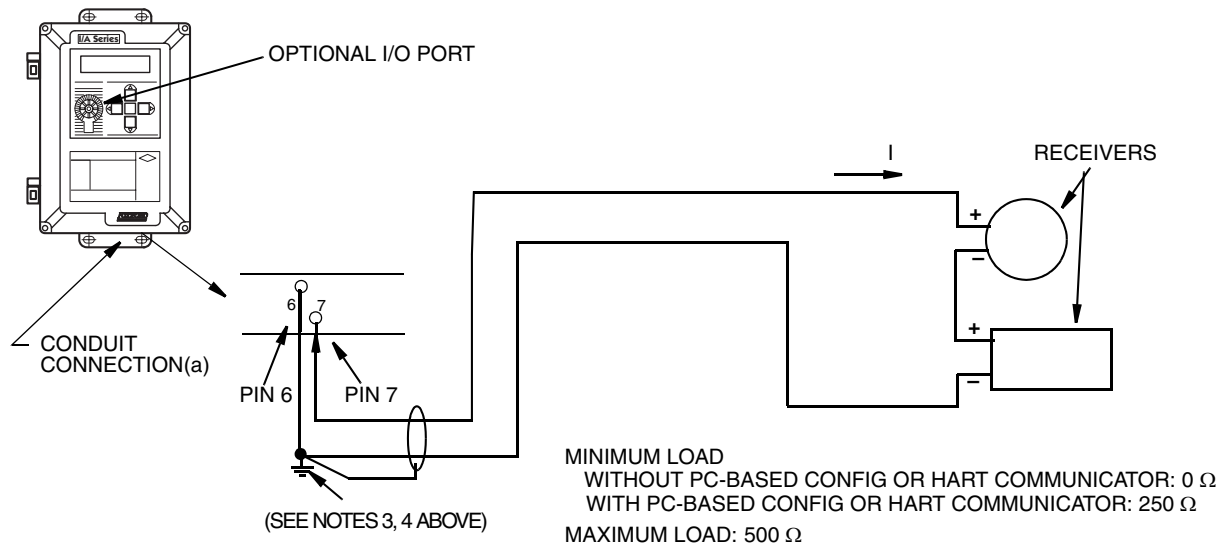

## NOTES:

- (a) RUN CONDUIT DOWN TO AVOID BUILD-UP OF MOISTURE IN TERMINALS COMPARTMENT. PLUG ANY UNUSED CONDUIT CONNECTION.
- (b) THE PC-BASED CONFIGURATOR OR HART COMMUNICATOR CAN BE PLUGGED INTO THE OPTIONAL I/O PORT OR CONNECTED ANYWHERE BETWEEN THE TRANSMITTER FIELD TERMINALS AND THE EXTERNAL LOAD.

*Figure 21. Typical Internally Powered 4 to 20 mA Output Wiring*

## Externally Powered Analog Output Circuit

The supply voltage and loop load relationship for externally powered 4 to 20 mA output wiring is shown in Figure 22. Any combination of supply voltage and loop load resistance in the lower shaded area can be used. To determine the total loop load resistance, add the series resistance of each component in the loop, excluding the flowmeter. The power supply must be capable of supplying 25 mA of loop current.

---

— **NOTE** —

1. External power is set by DIP switches. Refer to Figure 19 to verify or to change to internal power.
  2. Polarity is important when wiring and switching from internal power to external power and vice versa. See Figures 21 and 23.
-

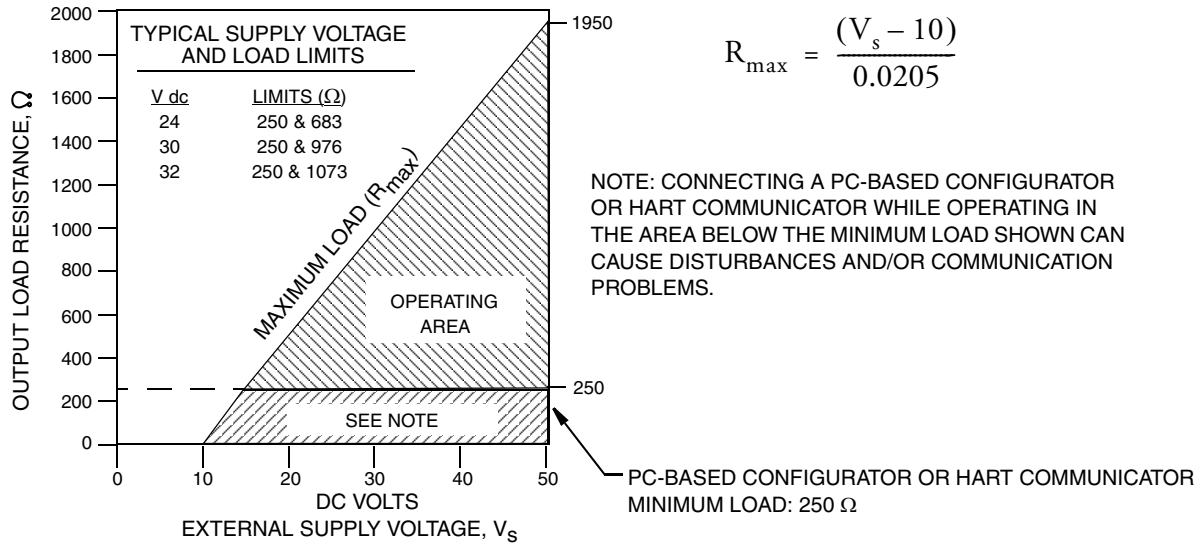

Figure 22. Supply Voltage and Loop Load Requirements for Externally Powered Analog Output Circuits

#### Examples:

1. For installation in an ordinary location with a total loop load resistance of 500 ohms, the supply voltage can be any value from 20 to 50 V dc.
2. For a supply voltage of 24 V dc, the loop load resistance can be any value from 0 to 683 Ω. If a PC-based Configurator or HART Communicator is used, a minimum loop resistance of 250 Ω is required.

#### — NOTE —

Grounding the loop at the negative terminal of the power supply is recommended but not required. If shielded wire is used for this signal, terminate the shield at the negative terminal of the power supply.

#### — ⚠ CAUTION —

To avoid errors resulting from ground loops or the possibility of short-circuiting groups of instruments in a loop, there should be only one ground in a loop.

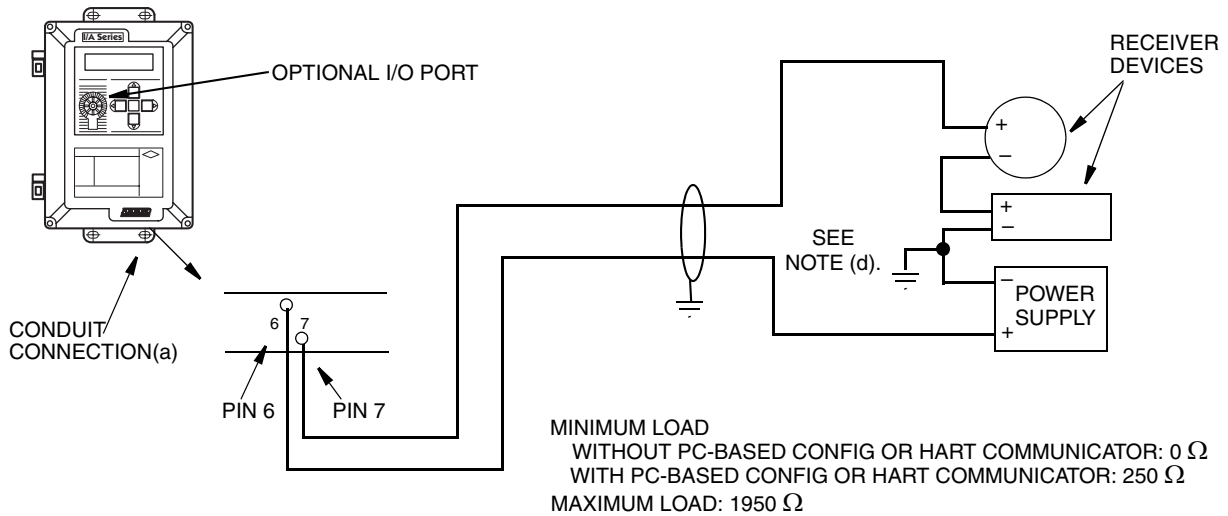

- (a) RUN CONDUIT DOWN TO AVOID BUILDUP OF MOISTURE IN TERMINALS COMPARTMENT. PLUG ANY UNUSED CONDUIT CONNECTION.
- (b) PC-BASED CONFIGURATOR OR HART COMMUNICATOR CAN BE PLUGGED INTO THE OPTIONAL I/O PORT OR CONNECTED ANYWHERE BETWEEN THE TRANSMITTER FIELD TERMINALS AND THE EXTERNAL LOAD.
- (c) IF STANDARD CABLE IS USED, CONNECT SHIELD TO NEGATIVE TERMINAL OF POWER SUPPLY.
- (d) GROUNDING AT NEGATIVE TERMINAL OF POWER SUPPLY IS RECOMMENDED. IF SHIELDED WIRE IS USED FOR THIS SIGNAL, TERMINATE SHIELD AT NEGATIVE TERMINAL OF POWER SUPPLY.

Figure 23. Typical Externally Powered 4 to 20 mA Output Wiring

## Pulse Output Circuit

Locations of pulse output terminals are shown in Figure 17. Wiring to these terminals is shown in Figure 25.

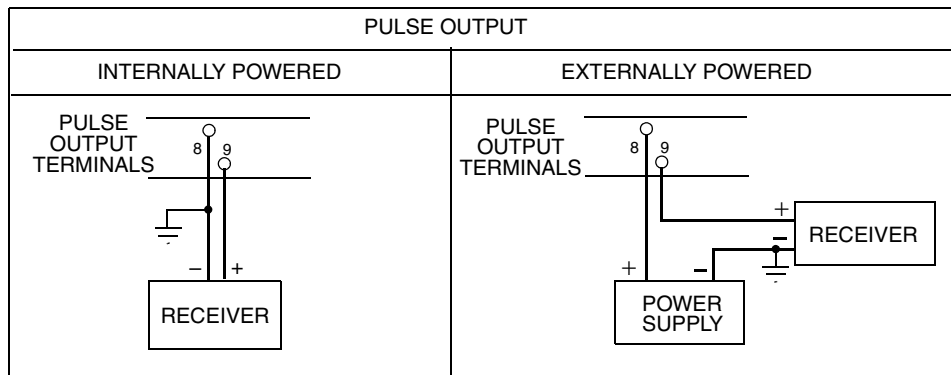

Figure 24. Pulse Output Wiring

**— NOTE —**

Internal or external power is set by DIP switches. Refer to Figure 19 to verify or change setting.

## Externally Powered

- ◆ The pulse output has two modes of operation:
  - a. Scaled pulse mode — used to drive a remote totalizer
  - b. Rate mode — used to transmit flow rate as a frequency.
- ◆ To install the pulse output wiring correctly, the pulse output mode should be known.
- ◆ For scaled pulse mode, observe the following supply voltage or load current limits:
 

Supply Voltage: 5 V dc min. to 42 V dc max.  
Load Current: 1 mA min. to 80 mA max.
- ◆ For rate mode, other considerations for proper circuit operation apply:
  - a. To maintain a low state voltage of 1 V max. at the receiver, observe the following load resistance range:

*Table 7. Load Resistance Range to Maintain Low State Voltage = 1 Volt Maximum*

Load Resistance	Supply Voltage		
	5 V	24 V	42 V
R <sub>min</sub>	62.5 ohms	300 ohms	525 ohms
R <sub>max</sub>	5000 ohms	5000 ohms	5000 ohms

b. Cable Capacitance/Lead length

When lead capacitance (C) and lead length (L) are considered, more stringent load resistance (R) restrictions apply.

For correct operation in the rate mode:

$$R_{\max} = \frac{K}{CL}$$

where

$$\begin{aligned}
 K &= 5 \times 10^{-6} && \text{for Rate Max Freq} = 10 \text{ kHz} \\
 &= 10 \times 10^{-6} && \text{for Rate Max Freq} = 5 \text{ kHz} \\
 &= 25 \times 10^{-6} && \text{for Rate Max Freq} = 2 \text{ kHz} \\
 &= 50 \times 10^{-6} && \text{for Rate Max Freq} = 1 \text{ kHz}
 \end{aligned}$$

Example:

If: Cable length is 1000 ft

Cable capacitance is 20 pF/ft

Desired maximum frequency is 5 kHz

$$\begin{aligned}
 \text{Then: } R_{\max} &= 10 \times 10^{-6} / ((20 \times 10^{-12}) \times (1000)) \\
 &= 500 \text{ ohms}
 \end{aligned}$$

Verify that the calculated value of R<sub>max</sub> falls within the limits defined in Table 7.

In general, smaller loads support higher frequencies and/or longer cable lengths. Inversely stated, lower frequencies support longer cable lengths and/or larger loads.

When confronted with a situation in which the input impedance of the receiving device is too large for the desired frequency and/or lead length, you can install a shunting resistor across the appropriate terminals of the receiver to satisfy the requirements stated above.

---

— **NOTE** —

Grounding externally powered pulse output at the negative terminal of the power supply is recommended.

---

### *Internally Powered*

The supply voltage of the pulse output, when internally powered, is 24 V dc  $\pm$ 15%.

To select the proper load, follow the recommendations for load limits given in “Externally Powered” on page 32.

---

— **NOTE** —

1. When internally powered, the analog/digital, pulse output, and contact input circuits share the same circuit reference. They are isolated from other circuits but not from each other.
  2. Grounding the internally powered pulse at pin 8 is recommended, but not required.
- 

## Contact Input and Relay Output Circuits

Locations of the contact input and relay output terminals are shown in Figure 17. Wiring to these terminals is shown in Figure 25.

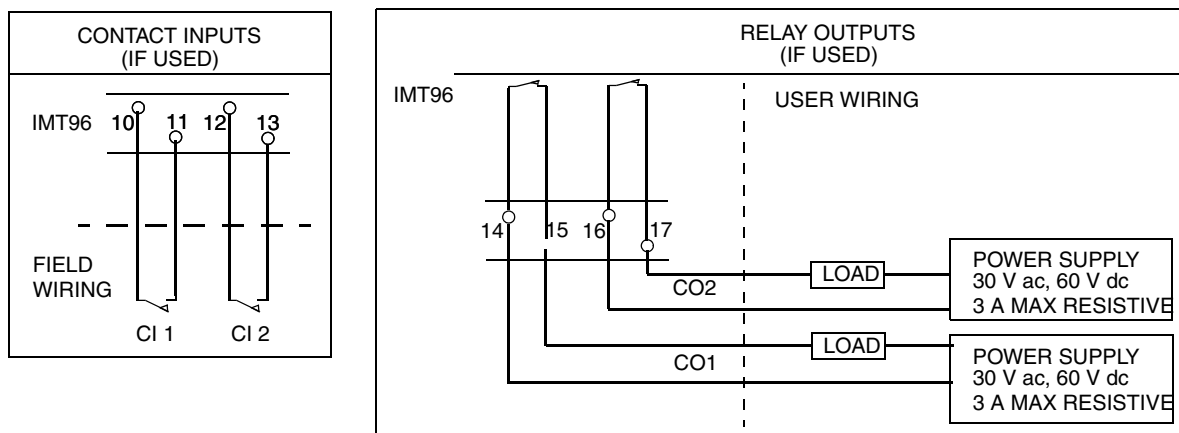

*Figure 25. Contact Input and Relay Output Wiring*

### *Contact Inputs*

The contact inputs require a contact closure or transistor switch between the terminal block connections provided.

The open circuit voltage is 24 V dc  $\pm$ 15%.

The closed circuit current is 12 mA  $\pm$ 15%.

— **NOTE** —

---

The analog/digital output and pulse output, when internally powered, share the same current reference as the contact inputs. They are isolated from other circuits, but not from each other.

---

## Relay Outputs

Voltage rating: 60 V dc max., 30 V ac rms max.

Current rating: 3 A max resistive

—  **WARNING** —

---

Relay outputs are not short-circuit-proof. External fuses are required if this feature is necessary.

---

Inductive loads can be driven with external surge-absorbing devices installed across contact terminations.



# ***Index***

## ***C***

Cable Glands 14  
Conduit Connections 13  
Conduit Hole Plugs 14

## ***D***

Dimensions 9

## ***G***

General Description 1

## ***I***

Identification 8

## ***M***

Mounting, Panel 12  
Mounting, Pipe 11  
Mounting, Surface 10

## ***O***

Operating Conditions 5  
Overview 1

## ***P***

Panel Mounting 12  
Pipe Mounting 11  
Plugs, Conduit Hole 14

## ***R***

Reference Documents 1

## ***S***

Specifications  
    Electrical Safety 7  
    Standard 3  
Surface Mounting 10

**U**

Unpacking and Handling 9

**W**

Wiring 13

Access to Terminals 15

Cable Description 22

Contact Input and Output Circuits 33

Digital Output Circuit 26

Externally Powered Analog Output Circuit 29

Flowtube to Transmitter 15

Internally Powered Analog Output Circuit 28

Pulse Output Circuit 31

Supply Power 25

Terminal Designations 22

Transmitter Output 26

Transmitter to Flowtube 22

Wire Preparation 16

Wire Specifications 15

Write Protect Switch 26

## ISSUE DATES

APR 1999

DEC 1999

DEC 2005

JUN 2006

OCT 2007

FEB 2009

Vertical lines to the right of text or illustrations indicate areas changed at last issue date.



IPS Corporate Headquarters  
5601 Granite Parkway Suite 1000  
Plano, TX 75024  
[www.ips.invensys.com](http://www.ips.invensys.com)

Foxboro Global Client Support  
Inside U.S.: 1-866-746-6477  
Outside U.S.: 1-508-549-2424 or  
contact your local Foxboro  
representative.  
Facsimile: 1-508-549-4999

Invensys, Foxboro, and I/A Series are trademarks of Invensys plc, its subsidiaries, and affiliates.  
All other brand names may be trademarks of their respective owners.

Copyright 1999-2009 Invensys Systems, Inc.  
All rights reserved

MB 100

Printed in U.S.A.

0209