

Intelligent Magnetic Flowmeter
MAG2IC - Flowmeter with Integrally Mounted Transmitter
MAG2RT - Remote Mounted Transmitter
MAG2RS - Remote Mounted Flowtube

Installation, Operation, and Maintenance

Contents

1. Introduction	1
Overview	1
Reference Documents	1
Standard Specifications	1
Product Safety Specifications	9
2. Installation	11
Criteria For Installation Location	11
Cautions On Surrounding Environment	11
Cautions On Measured Fluid	11
Warnings and Cautions During and After Installation	12
Installed Position	13
Changing the Direction of the Transmitter	14
Changing the Direction of the Local Display	17
Allowable Distance Between a Remote Transmitter and Flowtube	18
Installing a Wafer Type Flowtube	18
Basic Installation	18
Fastening Torque	19
Flange Shape	19
Examples of Unacceptable Installations	20
Gaskets	21
Installation on a Horizontal Pipe	22
Installation on a Vertical Pipe	23
Installation on Metal Pipe with 316 ss Grounding Ring	24
Installation on Metal Pipe with non-316 ss Grounding Ring	25
Installation on PVC pipe with 316 ss Grounding Ring	26
Installation on PVC Pipe with non-316 ss Grounding Ring	28
Installation a Flange Type Flowtube	29
Basic Installation	29
Fastening Torque	30
Flange shape	31
Gaskets	32
Installation on Metal Pipe with 316 ss Grounding Ring	33
Installation on Metal Pipe with non-316 ss Grounding Ring	34
Installation on PVC Pipe with 316 ss Grounding Ring	35
Installation on PVC Pipe with non-316 ss Grounding Ring	37
Installing a Remote-Type Transmitter	38
Wiring	39
Field Terminals	39
Wiring Your Transmitter	40
Cabling	41

Grounding	42
Wiring Connection of Power Supply and Analog Output	43
Input Circuit Such As Sequence Controllers	43
Wiring Connection for Pulse Output	44
Wiring Connection for Analog and Pulse Output	44
Wiring Connection for Contact Output	45
Wiring Procedure	45
Wiring the Power Supply	46
Wiring Connection Between Flowtube and Transmitter	47
Wiring Diagram for FM Nonincendive Installations	48
3. Start-Up and Shutdown	49
Start-Up	49
Shutdown	49
4. Operation Via Local Display	51
Startup Displays	51
Names and Descriptions of Parts	52
Displays	52
Keys	53
Write Protection	54
Description of Measuring Mode	57
Display Overview	57
Details of Display	57
Overview of Operation Using the Local Display	58
Configuration of Operator's Mode	60
Changing Setting of Damping Time Constant	63
Auto Zero Adjustment	64
Setting the Built-in Counter Reset Value	65
Resetting the Built-In Counter	66
Setting Auto Spike Cut	67
Setting Moving Average Processing	68
Setting Electrode Status Diagnostic Function	70
Selecting the Electrode Status Output Mode	80
Selecting Flow Rate To Be Displayed In the Main Display	81
Entering Engineering Mode and Maintenance Mode	82
Configuration of Engineering Mode	85
Setting ID	88
Selecting Pulse Output, Electrode Status Output, or High Low Status Output	88
Setting Flowtube Information	89
Setting the Flowtube Factor	90
Setting Flow Rate Range	91
Setting and Changing Compensation Coefficient	92
Setting Specific Gravity	93
Setting Pulse Scale	94
Setting Pulse Width	95
Setting Drop Out	99
Setting Low Flow Cutoff	99

Setting Upper and Lower Limit Alarm	100
Selecting Failsafe Mode For Analog Outputs	101
Selecting Failsafe Mode for Pulse Output	102
Setting Contact Output Status	103
Configuration of Maintenance Mode	104
Configuration of Output Check Mode	105
Performing Loop Checks of Analog Outputs by Using a Calibrator	106
Performing Loop Checks of Analog Outputs	107
Performing Loop Checks of Pulse Outputs	108
Performing Loop Checks of Contact Outputs	110
Configuration of Calibration Mode	111
Manual Zero	114
Configuration of Critical Mode	116
Displaying ROM Version and Date	117
Returning to Settings at Shipment	118
Description of Error Messages	119
Critical Failure	119
Error Code of Serious Trouble	119
Noncritical Error	120
Error Code Of Set Errors	120
5. Operation Via HART Communicator	121
Preparation for Communication, Verification and Cautions On Use	121
Wiring Between Transmitter and HART Communicator	121
Verifying Communication	121
Cautions	122
Setting and Calibrating Devices Using the HART Communicator	122
Setting procedures	123
Setting Transmitter Data	129
Signal Processing	132
Pulse Setting	136
Totalized Value Setting	138
Contact Output Setting	140
Burnout Setting	142
Calibrating and Inspecting the Device by HART Communicator and Other Functions	143
Device Adjustment	143
Output Check	151
Other Functions	157
Short Cut Commands and Menus for HART Communicator	160
6. Maintenance and Troubleshooting	165
Maintenance	165
Replacement of Local Display	165
Replacement of the Electronic Unit	166
Troubleshooting	170
Types of Troubles	170
Troubles at Startup	171
Troubles During Operation	171

Index 173

1. Introduction

Overview

The MAG2 series of high performance magnetic flowmeters are based on two-wire, loop powered technology. They are provided in an integrally mounted transmitter configuration, or with a remote transmitter.

Reference Documents

Table 1. Reference Documents

Document Number	Document Description
DP 021-500	Dimensional Print - MAG2IC Flowmeter with Integrally Mounted
DP 021-501	Transmitter
DP 021-502	Dimensional Print - MAG2RS Remote Mounted Flowtube Dimensional Print - MAG2RT Remote Mounted Transmitter
PL 008-750	Parts List - MAG2 Flowmeter

Standard Specifications

Ambient Temperature Limits

-20 and +60°C (-4 and +140°F)

Ambient Relative Humidity Limits

10 and 90% RH

Process Temperature and Pressure Range

See Figures 1 and 2.

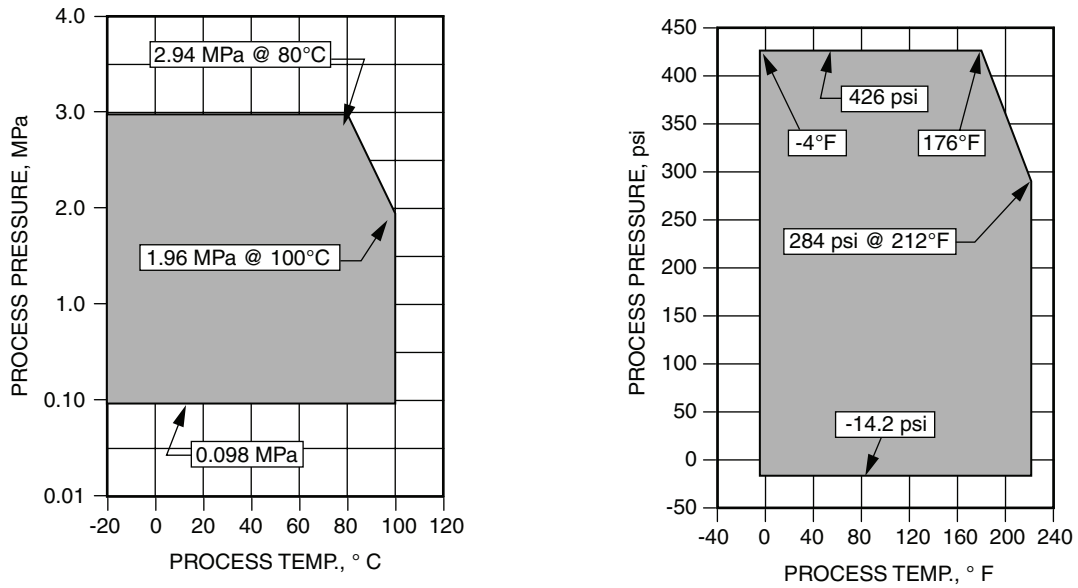

*Figure 1. Nominal Line Sizes 2.5 to 10 mm (0.1 to 3/8 in)
Process Temperature/Process Pressure Ranges*

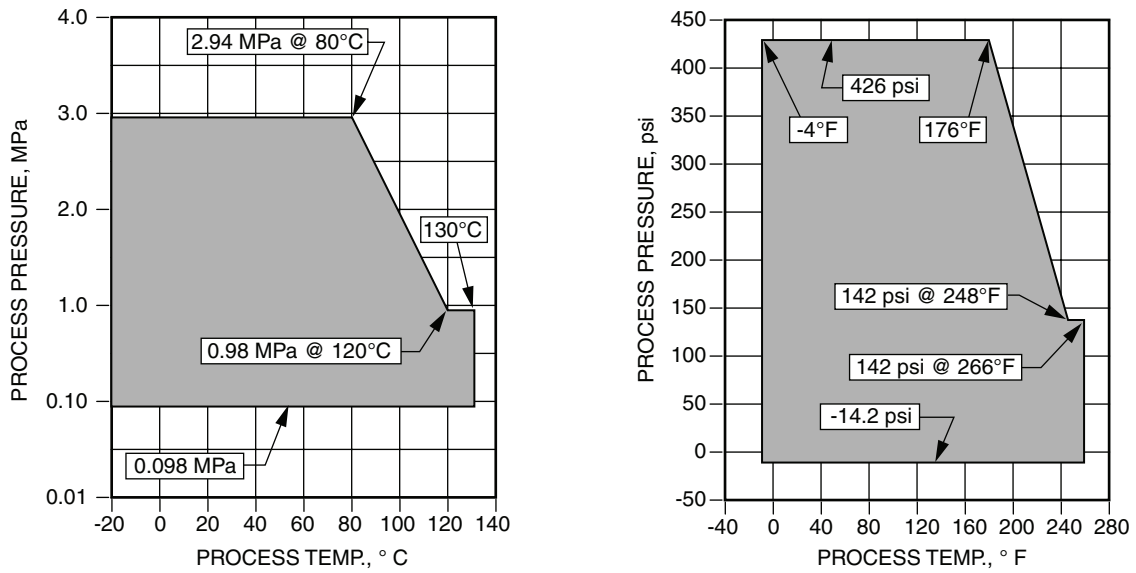

*Figure 2. Nominal Line Sizes 15 to 200 mm (1/2 to 8 in)
Process Temperature/Process Pressure Ranges*

Measurement Flow Range

Table 2. Measurement Flow Range

Nominal Line Size		When the Maximum Flow Velocity Range is: 0 to 0.3 m/s (0 to 0.98 ft/s) ^(a)		When the Maximum Flow Velocity Range is: 0 to 10 m/s (0 to 32.8 ft/s) ^(a)		Conversion Factor
		Then the Measurable Flow Range is:		Then the Measurable Flow Range is:		
mm	in	m ³ /h	GPM	m ³ /h	GPM	K
2.5	0.1	0 to 0.00531	0 to 0.02335	0 to 0.1767	0 to 0.778	56.59
5	0.2	0 to 0.02121	0 to 0.09337	0 to 0.7068	0 to 3.112	14.15
10	3/8	0 to 0.08483	0 to 0.3735	0 to 2.827	0 to 12.44	3.537
15	1/2	0 to 0.1909	0 to 0.8404	0 to 6.361	0 to 28.01	1.572
25	1	0 to 0.5302	0 to 2.335	0 to 17.67	0 to 77.80	0.5659
40	1½	0 to 1.358	0 to 5.976	0 to 45.23	0 to 199.1	0.2210
50	2	0 to 2.121	0 to 9.337	0 to 70.68	0 to 311.2	0.1415
65	2½	0 to 3.584	0 to 15.78	0 to 119.4	0 to 525.9	0.08371
80	3	0 to 5.429	0 to 23.90	0 to 180.9	0 to 796.7	0.05526
100	4	0 to 8.483	0 to 37.35	0 to 282.7	0 to 1244	0.03537
150	6	0 to 19.09	0 to 84.04	0 to 636.1	0 to 2801	0.01572
200	8	0 to 33.93	0 to 149.4	0 to 1130	0 to 4979	0.008842

(a) Velocity V (m/s) = $(K)(Q)$; where, K = Conversion Factor = $(1/3600)(4)(\pi D^2)(1000^2)$
and, D = Nominal Line Size (mm);
and, Q = Flow Rate (m³/h).

Enclosure Rating

Enclosure is dusttight and protected from the effects of immersion per IEC IP67, and provides the environmental and corrosion resistant protection of NEMA TYPE 4X.

Output Signal

Analog output: 4 to 20 mA dc

Digital output: For use with a HART Communicator or PC-Based Configurator.

Pulse output

Open collector output (30 V dc, 100 mA maximum)

Pulse frequency: 0.0001 to 200 Hz

Pulse width: 1 ms to 1 s.

Voltage drop during transistor ON: 1.6 V maximum

Contact output

Open collector output (30 V dc, 100 mA maximum)

Pulse or contact output is selectable

Power Supply (see Figure 3)

15.6 to 42 V dc (without communication)

21.05 to 42 V dc (with communication)

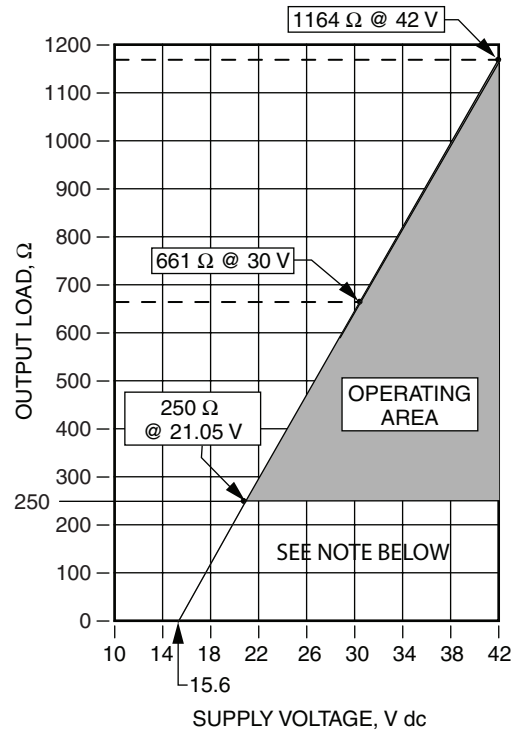

NOTE

A load resistance of 250 ohms or more is required for communications with a HART Communicator or PC-Based Configurator.

Figure 3. 4 to 20 mA Output Supply Voltage vs. Output Load

Current Capacity

24 mA minimum.

When the current capacity is 22 mA, the voltage must be 15.6 V minimum.

Flow Units

Volume flow: m³, L, cm³, G (gallon), mG, kG, B (barrel), IG (imperial gallon), mIG, kIG

Mass flow: kg, g, lb, t

Time: d, h, min, s

Display - LCD

Main display: 7-segment, 8 digits

Sub display: 16 digits, 2 lines

Display contents:

Simultaneously displays % flow rate, actual flow rate (engineering unit), and totalized value.

Data setting: Operation by four key switches

Damping

Adjustable between 0.5 and 199.9 seconds.

Low Flow Cutoff

Adjustable between 0 and 10% of setting range.

Below selected value, output is driven to the zero flow rate signal level.

Dropout

Adjustable between 0 and 10% of setting range. Below selected value, pulse output is cut.

Empty Pipe Detection

Detected by monitoring flow rate signal. Once flow rate signal fluctuates over a certain threshold, the device judges that the tube is empty. When the tube is empty, the analog 4 to 20 mA output and pulse output are set to zero flow values. The display alternately shows zero value and “Empty Status”.

There are three threshold levels to meet an environment where the device is installed. Set an appropriate threshold level from below.

- ◆ Sensitivity High
- ◆ Sensitivity Mid
- ◆ Sensitivity Low

Default setting: Off

Operating condition

The following conditions must be met when using the empty pipe detection function.

- ◆ Diameter: 10 mm or larger
- ◆ Electric conductivity of fluid: 30 $\mu\text{S}/\text{cm}$ or greater
- ◆ Grounding: Grounding resistance must be less than 100 Ω
- ◆ The noise level must be over the set threshold when the pipe is empty.

The noise level must be under the set threshold when the process fluid flows in the flowtube.

Size

Wafer Body

25, 40, 50, 65, 80, and 100 mm (1, 1½, 2, 2½, 3, and 4 in)

Flanged Body

2.5, 5, 10, 15, 25, 40, 50, 65, 80, 100, 150, and 200 mm

(3/8, 1/2, 1, 1½, 2, 2½, 3, 4, 6, and 8 in)

— NOTE

The 2.5 and 5 mm (0.1 and 0.2 in) flanged body flowtubes are available with the Model MAG2IC Flowmeter only.

Flange Rating

ANSI Class 150 and 300; DIN PN10, PN16, and PN25

Transmitter Enclosure Material

Low copper aluminum alloy

Transmitter Enclosure Finish

Standard: Baked acrylic paint

Corrosion-proof: Baked epoxy paint

Terminal Box Material (Model MAG2RS only)

Low Copper Aluminum alloy

Terminal Box Finish (Model MAG2RS only)

Standard: Baked acrylic paint

Corrosion-proof: Baked epoxy paint

Display Cover Material

Tempered glass

Flowtube Body Materials

Case material

Sizes 2.5 to 15 mm (0.1 to 1/2 inch): CF8M stainless steel

Sizes 25 to 200 mm (1 to 8 inches): 304 stainless steel

Measuring pipe material: 304 stainless steel

Flange Material

Sizes 2.5 to 65 mm (0.1 to 2 1/2 in): 304 stainless steel

Sizes 80 to 200 mm (3 to 8 in): Carbon steel with a corrosion resistance paint.

Process Wetted Materials

Lining: PFA

Electrodes

316L ss, Hastelloy C-276, Titanium, Tantalum, Nickel, Zirconium, or Platinum-Iridium

Earthing (Grounding rings)

316 ss, Hastelloy C-276, Titanium, Tantalum, Zirconium, or Platinum

Dimensions-Nominal

MAG2IC: See DP 020-500

MAG2RS: See DP 020-501

MAG-2RT: See DP 020-502

Approximate Weight: Model MAG2IC Flowmeters with Flanged Body Flowtubes

Nominal Line Size		Approximate Weight in kg (lb)			
		ANSI Flanges		DIN Flanges	
mm	in	150	300	PN 10/16	PN 25
2.5	0.1	6.4 (14.1)	6.9 (15.2)	6.9 (15.2)	7.1 (15.7)
5	0.2	6.4 (14.1)	6.9 (15.2)	6.9 (15.2)	7.1 (15.7)
10	3/8	6.4 (14.1)	6.9 (15.2)	6.9 (15.2)	7.1 (15.7)
15	1/2	6.6 (14.6)	7.1 (15.7)	7.1 (15.7)	7.3 (16.1)
25	1	8.4 (18.5)	9.5 (20.9)	9.1 (20.1)	9.4 (20.7)
40	1 1/2	7.8 (17.2)	10.1 (22.3)	8.7 (19.2)	9.7 (21.4)
50	2	12.3 (27.1)	13.8 (30.4)	13.3 (29.3)	13.8 (30.4)
65	2 1/2	14.3 (33.9)	15.8 (34.8)	15.3 (33.7)	15.8 (34.8)
80	3	17.3 (38.1)	21.3 (47)	14.4 (31.7)	16.5 (36.3)
100	4	25.1 (55.3)	34.2 (73.4)	19.6 (43.2)	23.4 (51.6)
150	6	37.2 (82)	56.2 (124)	30.7 (67.7)	38.6 (85.1)
200	8	61.8 (136)	90.8 (200)	48.1 (106)	68.5 (151)

Approximate Weight: Model MAG2IC Flowmeters with Wafer Body Flowtubes

Nominal Line Size		Approximate Weight	
mm	in	kg	lb
25	1	3.7	8.2
40	1 1/2	3.8	8.4
50	2	4.4	9.7
65	2 1/2	5.5	12.1
80	3	6.4	14.1
100	4	8.2	18.1

Approximate Weight: Model MAG2RT (Remote Mounted Transmitter)

2.8 kg (6.2 lb)

Approximate Weight: Model MAG2RS Flanged Body Flowtubes (Remote Mounted Transmitter)

Nominal Line Size		Approximate Weight in kg (lb)			
		ANSI Flanges		DIN Flanges	
mm	in	150	300	PN 10/16	PN 25
10	3/8	4.6 (10.1)	5.1 (11.2)	5.1 (11.2)	5.3 (11.7)
15	1/2	4.8 (10.6)	5.3 (11.7)	5.3 (11.7)	5.5 (12.1)
25	1	6.6 (14.6)	7.7 (17)	7.3 (16.1)	7.6 (16.8)
40	1 1/2	6 (13.2)	8.3 (18.3)	6.9 (15.2)	7.9 (17.4)
50	2	10.5 (23.1)	12 (26.5)	11.5 (25.4)	12 (26.5)
65	2 1/2	12.5 (27.6)	14 (30.9)	13.5 (29.8)	14 (30.9)
80	3	15.5 (34.2)	19.5 (43)	12.6 (27.8)	14.7 (32.4)
100	4	23.3 (51.4)	32.4 (71.4)	17.8 (39.2)	21.6 (47.6)
150	6	35.4 (78)	54.4 (120)	28.9 (63.7)	36.8 (81.1)
200	8	60 (132)	89 (196)	46.3 (102)	66.7 (147)

Approximate Weight: Model MAG2RS Wafer Body Flowtubes (Remote Mounted Transmitter)

Nominal Line Size		Approximate Weight	
mm	in	kg	lb
25	1	2	4.4
40	1 1/2	2	4.4
50	2	2.6	5.7
65	2 1/2	3.7	8.2
80	3	4.6	10.1
100	4	6.4	14.1

Product Safety Specifications

— NOTE —

The MAG2 series of products has been designed to meet the electrical safety descriptions listed below. For detailed information or status of testing laboratory approvals or certifications, contact Invensys.

Model MAG2IC Magnetic Flowmeter (Integrally Mounted Magnetic Flow Transmitter)

Testing Laboratory, Types of Protection, and Area Classification	Application Conditions	Electrical Safety Design Code
CSA Class I, Division 1, Groups A, B, C, and D; Class II, Division 1, Groups E, F, and G; and Class III, Division 1.	T4, Ta between -20 and +60°C.	1
CSA Class I, Division 2, Groups A, B, C, and D; Class II, Division 2, Groups E, F, and G; and Class III, Division 2.	T4, Ta between -20 and +60°C.	2
FM Class I, Division 1, Groups A, B, C, and D; Class II, Division 1, Groups E, F, and G; and Class II, Division 1.	T4, Ta between -20 and +60°C.	1
FM Nonincendive for Class I, Division 2, Groups A, B, C, and D; Class II, Division 2, Groups F and G; and Class III, Division 2. Also Class I, Zone 2, Group IIC.	T4, Ta between -20 and +60°C.	2

Model MAG2RT Remote Mounted Magnetic Flow Transmitter

Testing Laboratory, Types of Protection, and Area Classification	Application Conditions	Electrical Safety Design Code
CSA Class I, Division 2, Groups A, B, C, and D; Class II, Division 2, Groups E, F, and G; and Class III, Division 2.	T4, Ta between -20 and +60°C.	2
FM Nonincendive for Class I, Division 2, Groups A, B, C, and D; Class II, Division 2, Groups F and G; and Class III, Division 2. Also Class I, Zone 2, Group IIC.	T4, Ta between -20 and +60°C. Connect per Figure 50.	2

Model MAG2RS Remote Mounted Magnetic Flowtube

Testing Laboratory, Types of Protection, and Area Classification	Application Conditions	Electrical Safety Design Code
CSA Class I, Division 2, Groups A, B, C, and D; Class II, Division 2, Groups E, F, and G; and Class III, Division 2.	T4, Ta between -20 and +60°C.	2
FM Nonincendive for Class I, Division 2, Groups A, B, C, and D; Class II, Division 2, Groups F and G; and Class III, Division 2. Also Class I, Zone 2, Group IIC.	T4, Ta between -20 and +60°C. Connect per Figure 50.	2

2. Installation

Criteria For Installation Location

To maximize the performance of this instrument, choose the optimum installation location according to the following criteria.

Cautions On Surrounding Environment

—  **CAUTION** —
Install at a place where the ambient temperature is in the range from -4°F to +140°F (-20°C to +60°C) and ambient humidity in the range from 10 to 90% RH. Otherwise, instrument failure or output errors may result.

—  **CAUTION** —
Avoid a location subject to corrosive gases or excessive dust.

—  **CAUTION** —
Avoid a location close to a large-current cable, motor or transformer that may bring about inductive interferences. Otherwise, instrument failure or output errors may result.

—  **CAUTION** —
Avoid a place where there are severe vibrations or a highly corrosive atmosphere. Otherwise, a broken flowtube or damaged instrument may result.

—  **CAUTION** —
Avoid a place exposed to direct sunlight. Otherwise, output errors may result.

Cautions On Measured Fluid

The installation location must also satisfy the following conditions to avoid output errors and fluctuations.

—  **CAUTION** —
The electrical conductivity of the fluid to be measured must match the stated specifications (specs vary according to transmitter used) and should be more or less constant.

—⚠ CAUTION

The fluid to be measured must be electrochemically homogenized. For example, if two fluids are mixed at an upstream a point, the device should be installed at a point so that the two fluids can be evenly mixed by the time they reach the measuring point.

—⚠ CAUTION

For the accurate flow measurement, verify the zero point value in each excitation current (Manual zero1, manual zero2, and manual zero3) by using manual zero function, if the normal flow velocity is less than 0.3 m/s (0.98 ft/s).

—⚠ CAUTION

If an ingredient or additive is mixed in, the ingredient distribution must be nearly uniform or homogeneous.

—⚠ CAUTION

For the following fluids, do not use this instrument even if the electric conductivity, temperature, pressure and others are within the instrument specifications because they can cause problems in measurement.

1. Fluids that have sufficient conductivity at high temperatures, but do not satisfy the conductivity requirement at room temperature (about 68°F (20°C)). (For example, fatty acids and soap)
 2. Certain fluids that contain surfactant (for example, rinse, shampoo and CWM)
 3. Insulating adhesive materials (For example, oil, kaolinite, kaolin, calcium stearate)
 4. Slurry fluids containing solid matter (For example, pulp slurry, mud slurry, cement slurry)
 5. A circuit in some PLC may affect the flow measurement and the analog output may fluctuate.
-

—⚠ CAUTION

In this case, make sure that the both PLC and the MAG2 flowmeter are properly grounded. Proper grounding solves the fluctuation problem.

Warnings and Cautions During and After Installation

—⚠ WARNING

Before removing this unit, confirm that there is no residual liquid or pressure inside the piping and the flowtube to avoid personal injury on damage to the unit.

—⚠ CAUTION

Do not use this instrument as a foothold or for any other improper purpose. Doing so may result in damage to the instrument and/or physical injury.

! CAUTION

The integral type of this instrument uses glass for the transmitter window. Hitting the glass portion of the indicator with a tool may break the glass and/or cause physical injury.

NOTE

1. The output signal or indication may fluctuate depending on pulsation or other conditions of the fluid. In such cases, increase the damping time constant or take some other corrective measure.
 2. The analog output may fluctuate due to flow noise, which is generated by the process fluid flow. In such a case, connect the upstream grounding ring to the downstream grounding ring by a wire. The output fluctuation may be reduced.
-

Installed Position

Install the instrument at a place where the measured fluid always fills the inside of the flowtube. An example of installation is shown in Figure 4 to illustrate this condition

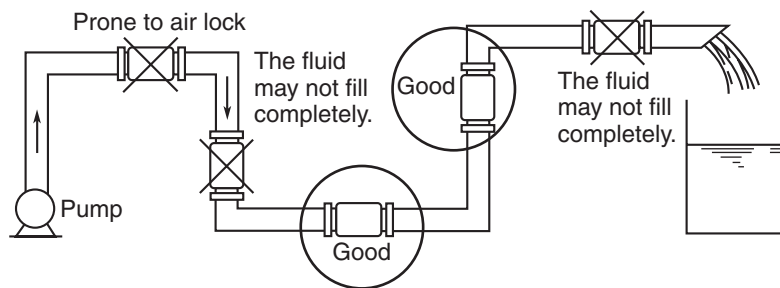

Figure 4. Example of Installation

The flowtube must be positioned as shown by the circled areas in the figure shown above. If the pipe is not filled, output errors will occur.

If the measured fluid is highly viscous, Invensys recommends installing the instrument on a vertical pipe, in order to secure an axial symmetrical flow.

Install a straight pipe section on the upstream side of the flowtube. For the straight section length, see Figure 5.

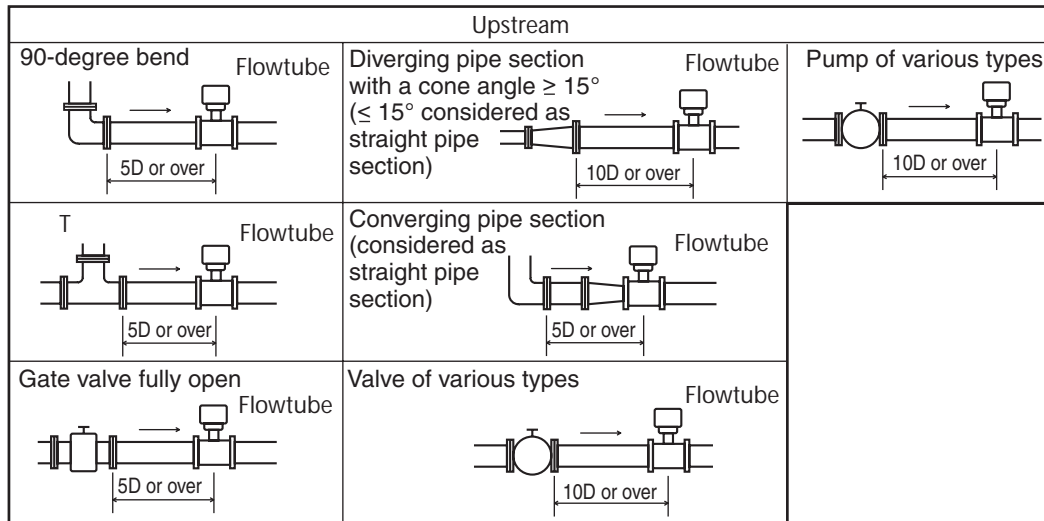

Figure 5. Straight Pipe Section Upstream of Flowtube

No specific straight pipe section is needed on the downstream side. However, two pipe diameters (2D) or over of straight pipe are recommended if influences of drift are foreseen.

Select an installation location where there is no major flow pulsation or vibration (away from a pump)

Ensure adequate maintenance space. See Figure 6.

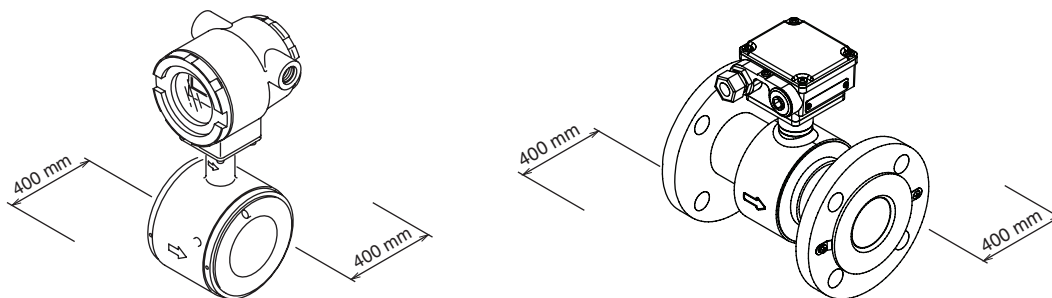

Figure 6. Maintenance Space

Changing the Direction of the Transmitter

In some locations, the direction of an integrally mounted transmitter may be unsuitable if the flowtube is installed as it was shipped. In this case, the transmitter can be repositioned before installation as follows:

1. Turn off the power supply to the transmitter (e.g., with a breaker).
2. Using an M5 wrench remove the four screws securing the transmitter to the flowtube.
3. Rotate the transmitter to the desired position.

! CAUTION

Do not to apply any force or load to the cable and the connectors. Failure to do so might cause damage to the cable, connector, printed circuit board or cause open circuit and malfunctions.

4. Tighten the four set screws to $4.4 \text{ N}\cdot\text{m}$ ($3.25 \text{ lb}\cdot\text{ft}$) $\pm 15\%$. Tighten the screws incrementally and diagonally so that the screws are tightened evenly.

NOTE

1. Disconnect all cables before proceeding to change the orientation of the flowtube and the transmitter.
 2. Do not perform the orientation change in locations containing humidity and dust.
 3. During reassembly check the sealing surface and the condition of the O-ring for any damage.
-

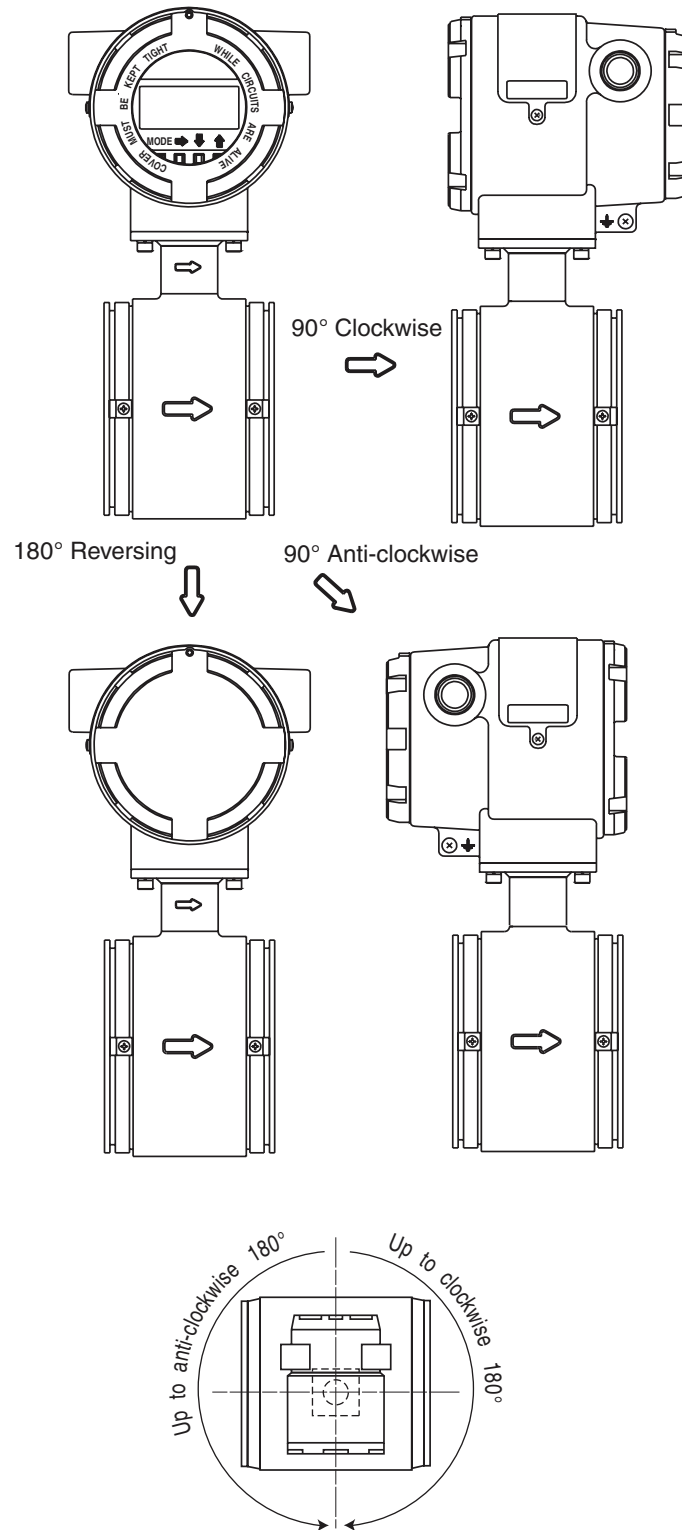

Figure 7. Change the Direction of Transmitter

Changing the Direction of the Local Display

The local display can be repositioned to a horizontal or vertical direction.

1. Turn off the power supply to the transmitter.
2. The transmitter front cover is secured by hexagon socket head set screws (M3). Loosen the set screws with a 1.5 mm hex-head wrench.
3. Remove the transmitter front cover by turning it counterclockwise.

—  **CAUTION** —

The local display unit is susceptible to damage from electrostatic discharge. Therefore, it should only be handled with the user grounded via a conductive wrist strap or other grounding device.

4. The local display unit is secured by three screws. Remove these screws using care not to drop them.

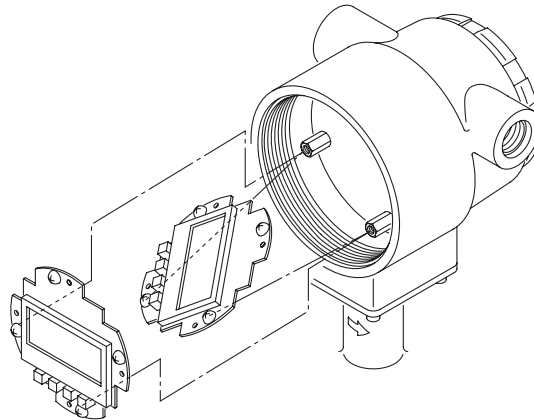

Figure 8. Changing the Display/Data Setting Device Direction

5. Remove the local display unit.
6. Turn the local display unit to the desired direction and align it to the threaded holes in the transmitter housing. See Figure 9 for allowable turning range.

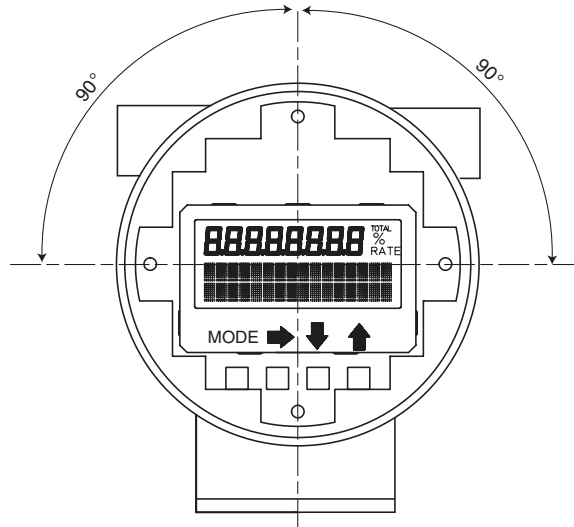

Figure 9. Movable Range of Display/Data Setting Device

7. Secure the local display unit using the three screws removed in Step 4. When tightening the screws, use care not to entangle the cable connecting the local display unit to the transmitter.
8. Reattach the front cover.

Allowable Distance Between a Remote Transmitter and Flowtube

The distance between a flowtube and a remote transmitter is limited by the flowtube size and the fluid conductivity as follows:

For a 10 mm (3/8 in) and 15 mm (1/2 in) flowtube with minimum conductivity of 50 $\mu\text{S}/\text{cm}$:

the cable length can be 2 to 10 m (6.5 to 98 ft).

For a 25 mm (1 in) and larger flowtube with minimum conductivity of 10 $\mu\text{S}/\text{cm}$:

the cable length can be 2 to 70 m (6.5 to 230 ft).

Installing a Wafer Type Flowtube

— **WARNING** —

Be careful in handling this unit. It is heavy; dropping it accidentally could cause injury.

Basic Installation

Figure 10 shows the basic method for installing the device.

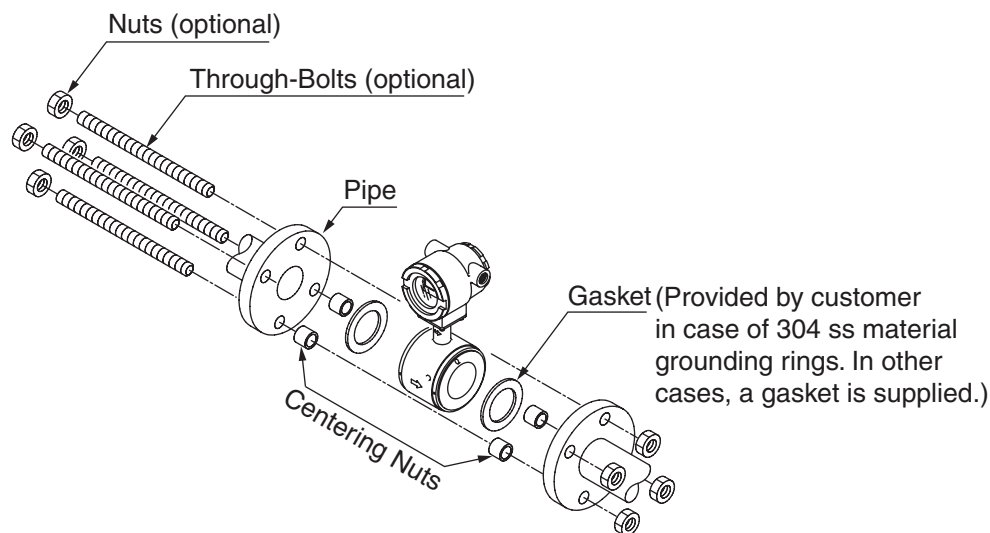

Figure 10. Wafer Type Flowtube Installation

Fastening Torque

Table 3 shows the fastening torque for each pipe bore. Using centering hardware, apply the prescribed fastening torque to prevent any liquid leak from the pipe.

Table 3. Fastening Torque

Nominal Flowtube Bore	Fastening Torque
25 mm (1 in)	20 to 30 N•m (14.7 to 22.1 ft•lb)
40 mm, 50 mm, 65 mm, 80 mm (1 1/2, 2, 2 1/2, 3 in)	30 to 50 N•m (22.1 to 36.8 ft•lb)
100 mm (4 in)	50 to 70 N•m (36.8 to 51.6 ft•lb)

— CAUTION —

Tighten each bolt a little at a time and apply uniform torque to all the bolts. If leakage does not stop on completion of fastening, make sure that the pipe is not off center, then tighten each bolt little by little. Install the flowtube carefully and ensure continue to that the fastening torque does not exceed the prescribed limit, otherwise the flowtube could be damaged.

Flange Shape

The flanges used should be such that the area of contact with the gasket is maximized, as shown in Figure 11.

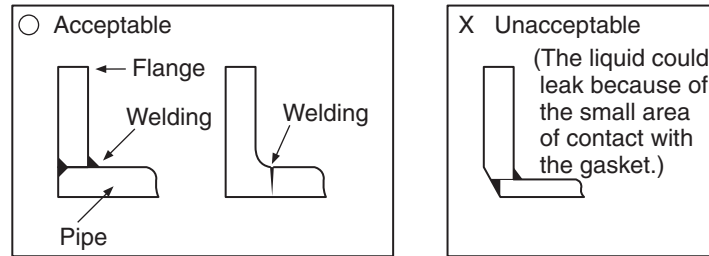

Figure 11. Flange Shape

— **NOTE** —

1. Before installing the flowtube be sure to flush out any foreign matter that may be present inside the flowtube. Residual foreign matter could cause output fluctuations.
2. Do not touch the electrodes with your hand or oily waste cloth. It could cause output fluctuations.
3. Install the flowtube so that the flow direction mark on the flowtube points in the direction of the liquid flow. Installing it in the wrong direction results in a negative output.
4. After ensuring that the bore diameters of the pipe and the flowtube are the same, install the flowtube so that the gasket does not protrude into the internal bore of the pipe. Failure to do this could result in leakage or other hazards.

Examples of Unacceptable Installations

— **! CAUTION** —

Before installing the flowtube, make sure that the pipe is exactly straight and centered. Any irregularity in these respects could cause leakage or other hazards.

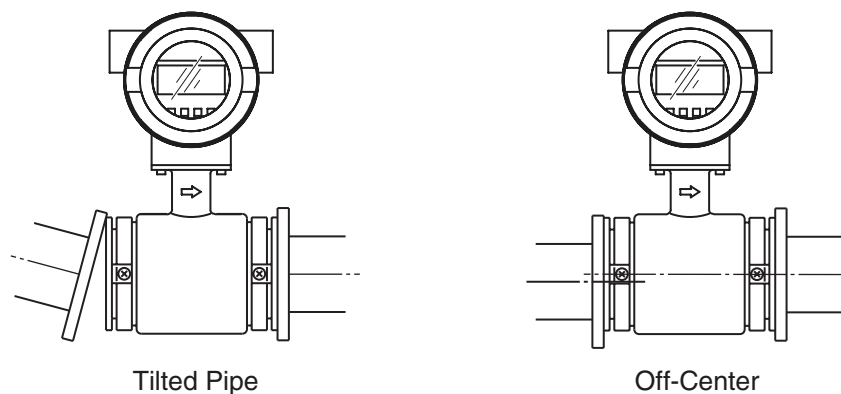

Figure 12. Unacceptable Alignment Installations

! CAUTION

Never attempt to force the flowtube between two piping flanges when the space is too narrow. It can damage the flowtube.

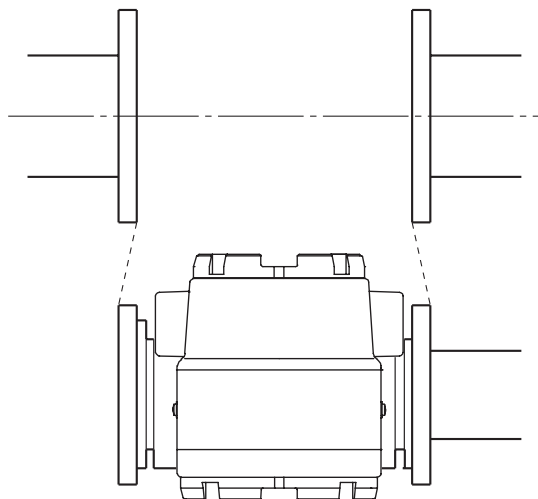

Figure 13. Unacceptable Spacing Installations

Gaskets

Gaskets are supplied with the grounding ring as standard accessory, except when it is made of 316 ss material. Secure gaskets when you use a grounding ring made of 316 ss material. We recommend gasket material such as PTFE. For the internal diameters of the gaskets, refer to Table 4. We do not recommend the use of rubber gaskets. Observe the precautions below.

! CAUTION

1. A gasket with too small internal diameter may generate turbulent flow, resulting in inaccurate measurements.
 2. A gasket with too large internal diameter may cause leakage. Also, any solid substance in the fluid to be measured could accumulate between the gasket and the flange, resulting in inaccurate measurements.
-

Table 4. Recommended Internal Diameters of Gaskets in Millimeters

Nominal Flowtube Bore	25 mm (1 inch)	40 mm (1½ inches)	50 mm (2 inches)	65 mm (2½ inches)	80 mm (3 inches)	100 mm (4 inches)
Gasket internal diameter	25.5±1	40.5±1	52±1	65±1	79±1	104±1

If you install the flowtube at a lower torque level using rubber gaskets, you must use gaskets with the internal and external diameters shown in Table 5. and Table 6. for the respective pipe size. Depending on the grounding ring material, two gaskets of different thicknesses may be required. (See Figures 19 and 22.)

Table 5. Internal and External Diameters of Rubber Gaskets (0.5 to 1 mm Thick) in mm

Nominal Flowtube Bore	25 mm (1 inch)	40 mm (1½ inch)	50 mm (2 inches)	65 mm (2½ inches)	80 mm (3 inches)	100 mm (4 inches)
Gasket internal diameter	25.5±1	40.5±1	52±1	65±1	79±1	104±1
Gasket external diameter	50±1	75±1	91±1	111±1	121±1	146±1

Table 6. Internal and External Diameter of Rubber Gaskets (3 to 4 mm Thick) in mm

Nominal Flowtube Bore	25 mm (1 inch)	40 mm (1½ inch)	50 mm (2 inches)	65 mm (2½ inches)	80 mm (3 inches)	100 mm (4 inches)
Gasket internal diameter	25.5 ±1	40.5 ±1	52 ±1	65 ±1	79 ±1	104 ±1
Gasket external diameter	50 ±1	68 ±1	84 ±1	104 ±1	114 ±1	139 ±1

Installation on a Horizontal Pipe

— CAUTION —

Improper installation may result in leakage or cause damage to the pipe flanges.

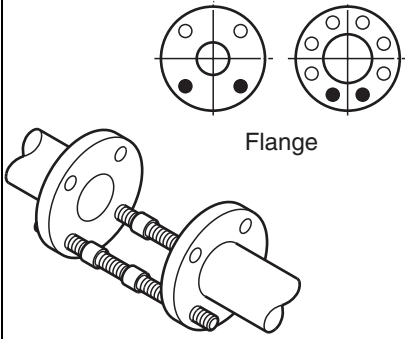
Step	Action	Drawing
1	<ul style="list-style-type: none"> Insert through-bolts in the flange holes shown by black dots in the drawing. Slip two centering nuts onto each through-bolt before inserting the bolts. 	

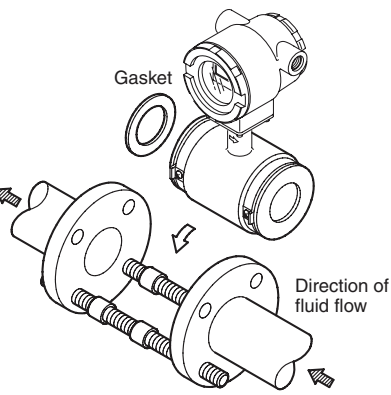
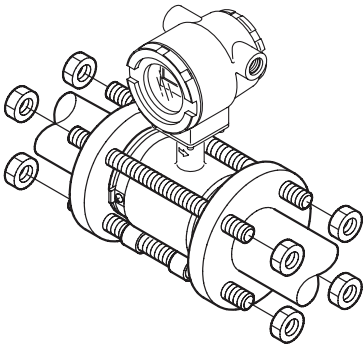
Step	Action	Drawing
2	<ul style="list-style-type: none"> • Turn the flowtube so that the direction mark on the flowtube matches the direction of fluid flow. • Insert the flowtube and gaskets between the pipe flanges. • Position the flowtube so that it sits on top of the centering nuts. 	
3	<ul style="list-style-type: none"> • Make sure that the flowtube remains properly centered. • Make sure that the gaskets do not protrude beyond the edges of the pipe flanges. • When you have checked these items, insert the remaining through-bolts into the flange holes and tighten the bolts evenly using the appropriate fastening torque given in Table 3. 	

Installation on a Vertical Pipe

⚠ CAUTION

Improper installation may result in leakage or cause damage to the pipe flanges.

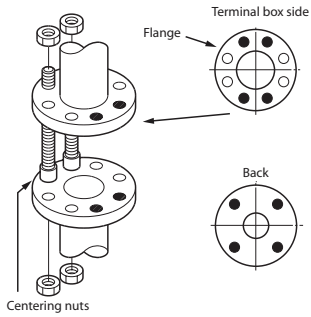
Step	Action	Drawing
1	<p>Of the flange holes shown by black dots in the drawing, insert through-bolts into the two holes at the back and fasten them lightly with nuts. Slip one centering nut onto each through bolt before inserting the bolts.</p>	

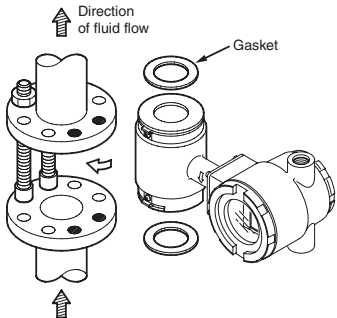
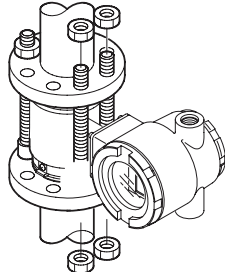
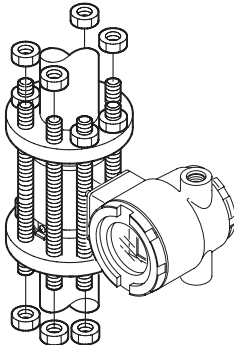
Step	Action	Drawing
2	<ul style="list-style-type: none"> • Turn the flowtube so that the direction mark on the flowtube matches the direction of fluid flow. • Insert the flowtube and gaskets between the pipe flanges. 	
3	<ul style="list-style-type: none"> • Insert through-bolts fitted with one centering nut each into the remaining two flange holes shown by black dots in steps 1 and 2. 	
4	<ul style="list-style-type: none"> • Make sure that the flowtube remains properly centered. • Make sure that the gaskets do not protrude beyond the edges of the pipe flanges. • When you have checked these items, insert the remaining through-bolts into the flange holes and tighten the bolts evenly using the appropriate fastening torque given in Table 3. 	

Installation on Metal Pipe with 316 ss Grounding Ring

Install the flowtube as shown in Figure 14. The torque level for tightening the bolts is not related to the gasket material. See Table 3 for the appropriate torque. For the internal diameter of the gaskets, see Table 4.

To use rubber gaskets for a low fastening torque, refer to page 27.

— CAUTION —

Please note that the use of rubber gaskets and a lower fastening torque may result in insufficient surface pressure between the lining and the grounding ring, resulting in leakage.

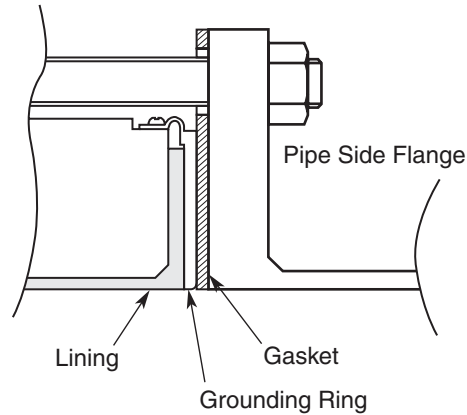

Figure 14. Installation on Metal Pipe with 316 ss Grounding Ring

Installation on Metal Pipe with non-316 ss Grounding Ring

Install the flowtube as shown following figures. See Table 3 for the appropriate fastening torque.

To use rubber gaskets for a low fastening torque, refer to page 28.

— CAUTION —

Please note that the use of an additional gasket besides the existing PTFE gasket may result in leakage (see Figure 15).

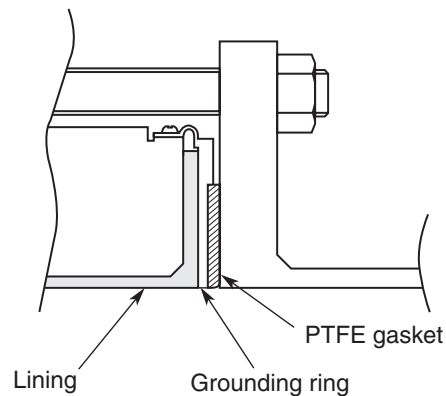

Figure 15. Installation on Metal Pipe with non-316 ss Grounding Ring

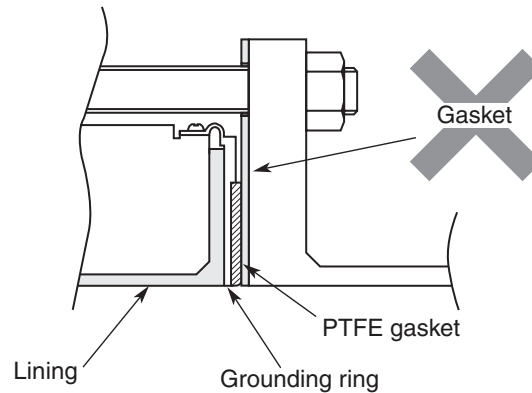

Figure 16. Example of Incorrect Installation

Installation on PVC pipe with 316 ss Grounding Ring

— NOTE —

Non-rubber gaskets are recommended (for example, PTFE). See Table 4 for the recommended bore diameters. When using rubber gaskets, another gasket of the same material and with a thickness of 0.5 to 1.0 mm is required. See Table 5 for the appropriate dimensions.

The installation procedure varies with such conditions as the fastening torque and the need for a protective plate (user supplied). Choose one of the following three methods as applicable.

1. Use this method to install the flowtube with a specified fastening torque. Install the flowtube as shown in Figure 17. The torque level for tightening the bolts is not related to the gasket material. See Table 3 for the appropriate torque. For the internal diameter of the gaskets, see Table 4.

— ! CAUTION —

The use of rubber gaskets and a lower fastening torque may result in insufficient surface pressure between the lining and the grounding ring, resulting in leakage

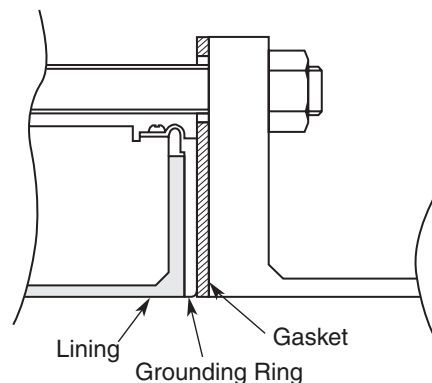

Figure 17. Installation on PVC Pipe with 316 ss Grounding Ring

- Use this method to install the flowtube using a protective plate to prevent the PVC pipe from being deformed or damaged when the bolts are tightened with the specified torque. Install the protective plate between the outer side of the PVC flange and the flowtube, as shown in Figure 18. The protective plate protects the PVC pipe from deformation or damage when secured at the specified torque. The torque level is unrelated to the pipe or grounding ring material. See Table 3 for the appropriate torque.

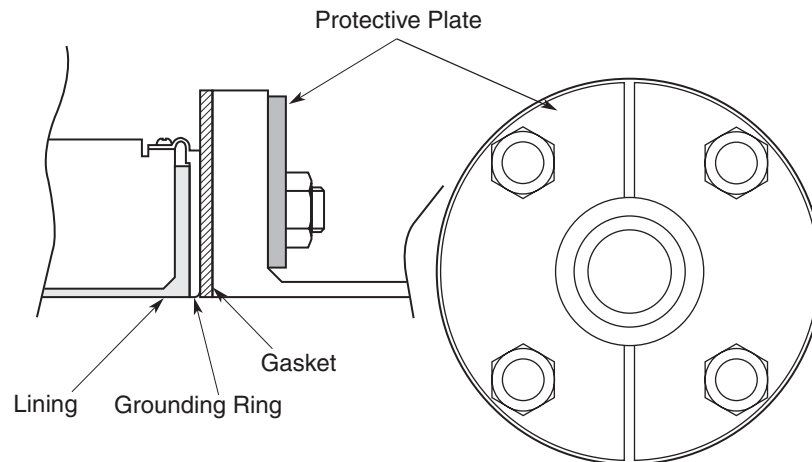

Figure 18. Installation on PVC Pipe with 316 ss Grounding Ring (with Protective Plate)

- Use this method to install the flowtube using a low fastening torque and rubber gaskets. Remove the grounding ring from the flowtube, insert a rubber gasket (0.5 to 1.0 mm thick), then reinsert the grounding ring on top of the rubber gasket. With the rubber gasket (3 to 4 mm) in the position shown in Figure 19, attach the flowtube to the pipe. Fasten the bolts with a torque that provides a leakproof joint. In this case, the two kinds of rubber gaskets must be made of the same material.

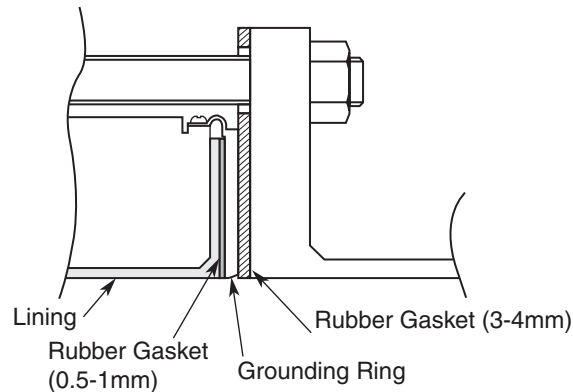

Figure 19. Installation on PVC Pipe with 316 ss Grounding Ring (with Rubber Gasket)

Installation on PVC Pipe with non-316 ss Grounding Ring

The installation procedure varies with such conditions as the fastening torque and the need for a protective plate (user supplied). Choose one of the following three methods as applicable. Use this method to install the flowtube with the specified fastening torque.

1. Install the flowtube as shown in Figure 20. See Table 3 for the appropriate fastening torque.

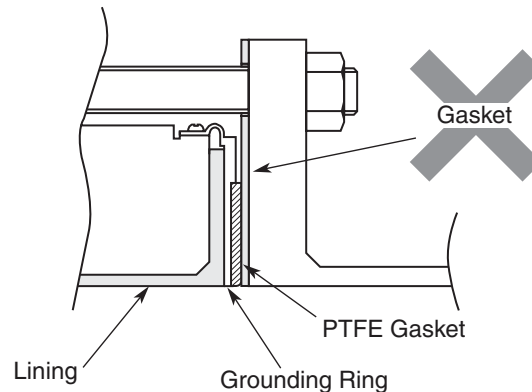

Figure 20. Installation on PVC Pipe with non-316 ss Grounding Ring

2. Use this method to install the flowtube along with a protective plate to prevent PVC pipe from being deformed or damaged when the bolts are tightened to the specified torque. Insert a protective plate between the outer side of the PVC flange and the flowtube as shown in Figure 21. The protective plate protects the PVC pipe from deformation or damage when it is secured to the specified torque. For the appropriate torque, see Table 3.

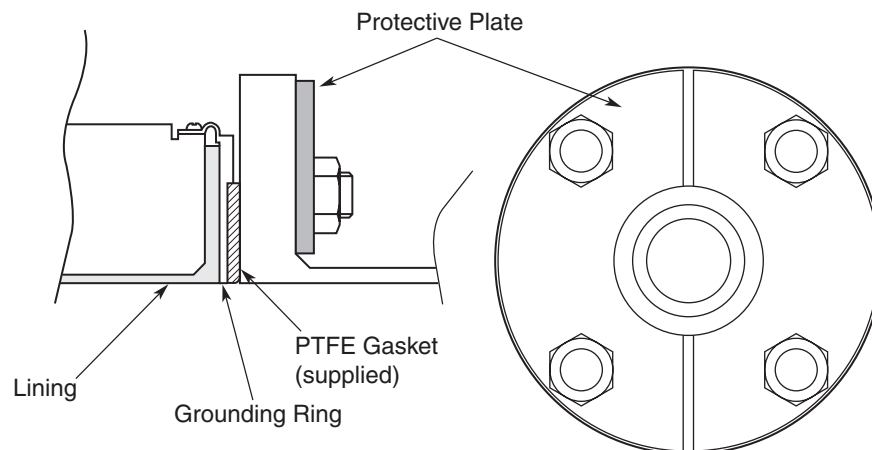

Figure 21. Installation on PVC Pipe with non-316 ss Grounding Ring (with Protective Plate)

3. Use this method to install the flowtube using a low fastening torque and rubber gaskets. First, remove the grounding ring from the flowtube, then insert a rubber gasket with a thickness of 0.5 to 1.0 mm. Then reinsert the grounding ring on top of

the rubber gasket. Next, remove the PTFE gasket and insert a rubber gasket 3.0 to 4.0 mm thick to replace it. Under these conditions, install the flowtube on the pipe as shown in Figure 22. Tighten the bolts to the torque required to achieve a fluid seal for the rubber gasket. In this case, the two kinds of rubber gaskets that are used should be made of the same material. For the dimensions of the rubber gaskets, refer to Tables 5 and 6.

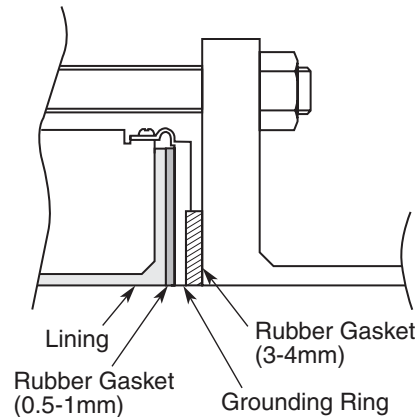

Figure 22. Installation on PVC Pipe with non-316 ss Grounding Ring (with Rubber Gaskets)

Installation a Flange Type Flowtube

— **WARNING** —

Be careful in handling this unit. It is heavy, dropping it accidentally could cause injury.

Basic Installation

Figure 23 shows the basic method for installing the device.

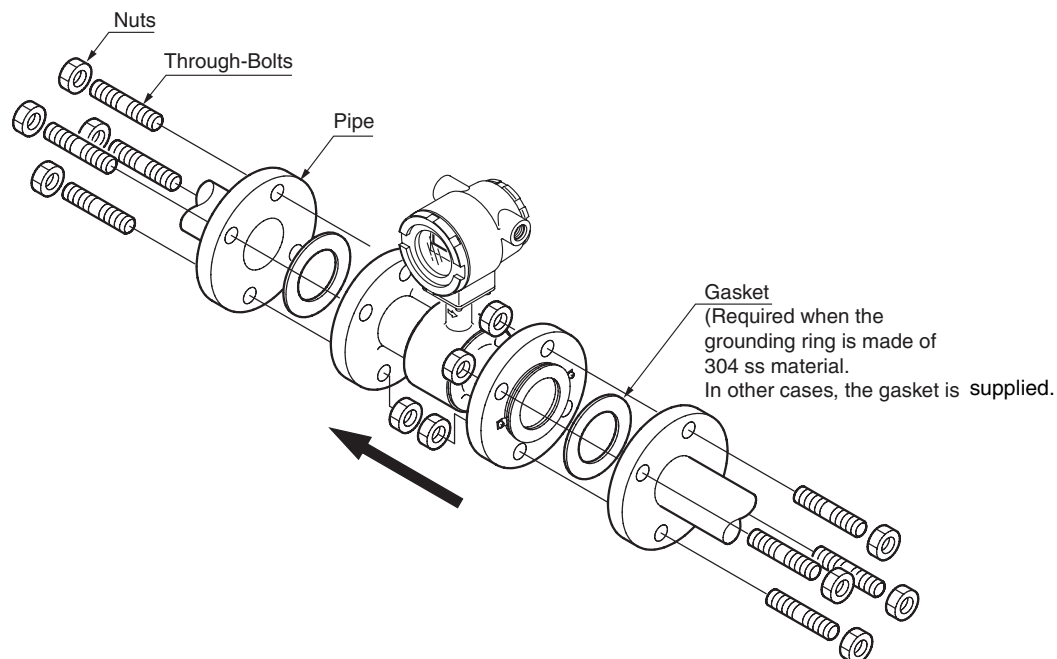

Figure 23. Flange Type Flowtube Installation

Fastening Torque

Table 7 shows the fastening torque for each pipe bore. Apply the prescribed fastening torque to prevent leakage.

Table 7. Fastening Torque

Diameter and Flange Ratings		Fastening Torque	
		lb•ft	N•m
2.5 to 15 mm (0.1 to 1/2 in)	ANSI Class 150	6.6 to 10.3	9 to 14
	ANSI Class 300	7.4 to 11.8	10 to 16
	DIN 10/16	5.9 to 9.6	8 to 13
	DIN 25	6.6 to 10.3	9 to 14
25 mm (1 inch)	ANSI Class 150	8.1 to 12.5	11 to 17
	ANSI Class 300	16.2 to 25.1	22 to 34
	DIN 10/16	7.4 to 10.3	10 to 14
	DIN 25	8.9 to 13.3	12 to 18
40 mm (1½ inch)	ANSI Class 150	9.6 to 13.3	13 to 18
	ANSI Class 300	26.6 to 42.0	36 to 57
	DIN 10/16	16.2 to 23.6	22 to 32
	DIN 25	18.4 to 28.0	25 to 38

Table 7. Fastening Torque

Diameter and Flange Ratings		Fastening Torque	
		lb•ft	N•m
50 mm (2 inches)	ANSI Class 150	17.0 to 23.6	23 to 32
	ANSI Class	14.8 to 23.6	20 to 32
	300DIN 10/16	17.7 to 25.1	24 to 34
	DIN 25	20.7 to 31.0	28 to 42
65 mm (2½ inches)	ANSI Class 150	19.2 to 25.8	26 to 35
	ANSI Class	27.3 to 42.0	37 to 57
	300DIN 10/16	17.7 to 25.1	24 to 34
	DIN 25	20.7 to 31.0	28 to 42
80 mm (3 inches)	ANSI Class 150	19.2 to 25.8	26 to 35
	ANSI Class	27.3 to 42.0	37 to 57
	300DIN 10/16	14.8 to 22.9	20 to 31
	DIN 25	18,4 to 28.8	25 to 39
100 mm (4 inches)	ANSI Class 150	15.5 to 22.9	21 to 31
	ANSI Class	31.7 to 48.7	43 to 66
	300DIN 10/16	16.2 to 24.3	22 to 33
	DIN 25	35.4 to 54.6	48 to 74
150 mm (6 inches)	ANSI Class 150	31.0 to 44.3	42 to 60
	ANSI Class	36.9 to 54.6	50 to 74
	300DIN 10/16	34.7 to 50.2	47 to 68
	DIN 25	90.7 to 139.4	123 to 189
200 mm (8 inches)	ANSI Class 150	31.0 to 43.5	42 to 59
	ANSI Class 300	59.7 to 88.5	81 to 120
	DIN 10/16	34.7 to 50.2	47 to 68
	DIN 25	90.7 to 139.4	123 to 189

Flange shape

Use flanges that will maximize the area of contact with the gasket, as shown in Figure 24.

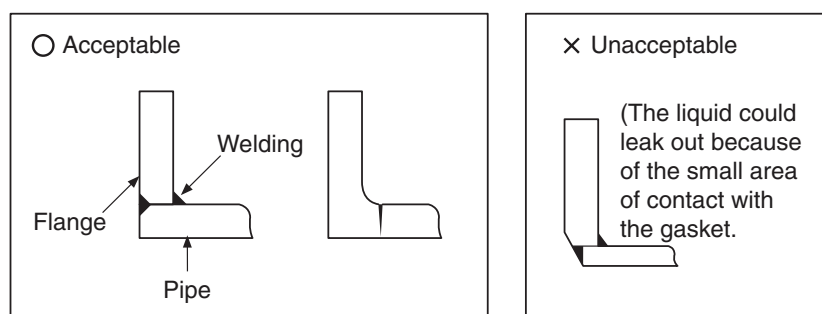

Figure 24. Flange Shape

— NOTE

1. Before installing the flowtube, make sure any foreign matter is flushed from the inside of the flowtube. Residual foreign matter could cause output fluctuations.
2. Do not touch the electrodes with your hand or oily waste cloth. It could cause output fluctuations.
3. Install the flowtube so that the flow direction mark on the flowtube points in the direction of the liquid flow. Installing it in the wrong direction results in a negative output.
4. Never attempt to force the flowtube between two flanges when the space is too narrow. It can damage the flowtube.

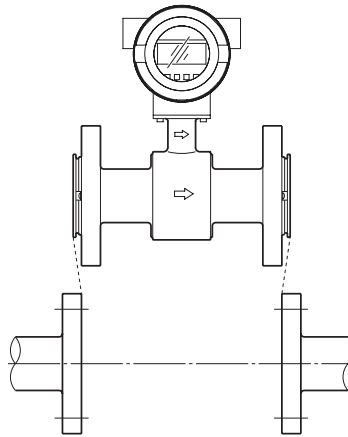

Figure 25. Example of Incorrect Mounting

— ! WARNING

After ensuring that the internal diameter of the pipe and that of the flowtube are the exactly the same, install the flowtube so that the gasket does not protrude into the internal diameter of the pipe. Failing to do so could result in leakage or other hazards.

— NOTE

Tighten each bolt a little at a time, apply uniform torque to all the bolts. If leakage does not stop on completion of fastening, make sure that the pipe is not off center, then continue to tighten each bolts little by little. Install the flowtube carefully and ensure that the fastening torque does not exceed the prescribed limit. Otherwise, the flowtube could be damaged.

Gaskets

Gaskets are supplied with the grounding ring, except when it is made of 316 ss material. Gasket are to be provided by the customer when using a grounding ring made of 316 ss material. We recommend a non-rubber gasket material such as PTFE.

For the internal diameters of the gaskets, refer to Table 8.

— NOTE —

1. A gasket with small internal diameter may generate turbulent flow and affect, resulting in inaccurate measurements.
2. A gasket with too large internal diameter may cause leakage. Also, any solid substance in the fluid to be measured could accumulate between the gasket and the flange, resulting in inaccurate measurements.

Table 8. Recommended Internal Diameters of Gaskets

Body Diameter	Internal Diameter (mm)
2.5 mm	11±1
5 mm	11±1
10 mm	11±1
15 mm (½ inch)	16±1
25 mm (1 inch)	25±1
40 mm (1½ inch)	40±1
50 mm (2 inches)	51±1
65 mm (2½ inches)	64±1
80 mm (3 inches)	76±1
100 mm (4 inches)	95±1
150 mm (6 inches)	148±1
200 mm (8 inches)	196±1

Installation on Metal Pipe with 316 ss Grounding Ring

Install the flowtube as shown in Figure 26. The torque level for tightening the bolts is not related to the gasket material. See Table 7 for the appropriate torque. For the internal diameter of the gaskets, see Table 4.

— ⚠ CAUTION —

A lower fastening torque may result in insufficient surface pressure between the lining and the grounding ring, resulting in leakage.

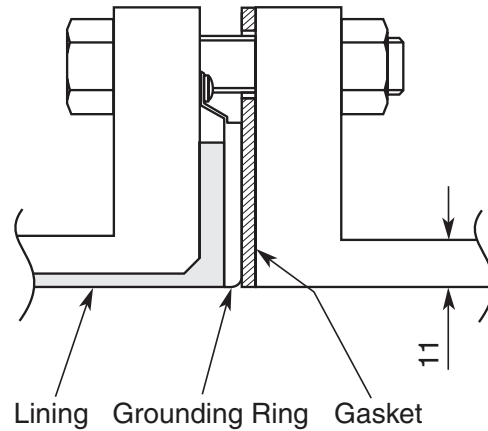

Figure 26. Installation on Metal Pipe with 316 ss Grounding Ring

Installation on Metal Pipe with non-316 ss Grounding Ring

Install the flowtube as shown in Figure 27. See Table 7 for the appropriate fastening torque.

⚠ CAUTION

Use of an additional gasket besides the existing PTFE gasket may result in leakage (see Figure 28).

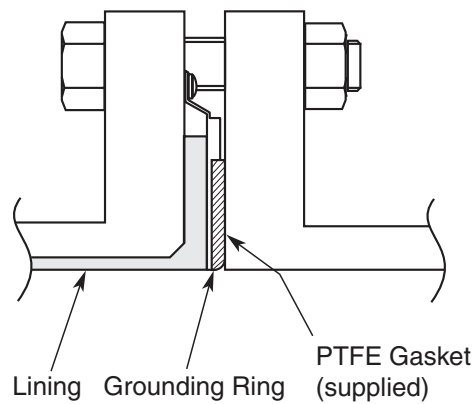

Figure 27. Installation on Metal Pipe with non-316 ss Grounding Ring

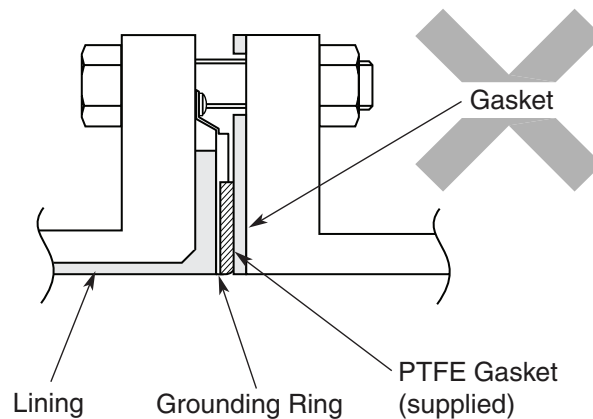

Figure 28. Example of Incorrect Installation

Installation on PVC Pipe with 316 ss Grounding Ring

The installation procedure varies depending on conditions such as the fastening torque and the need for a protective plate (user supplied). Choose one of the following three methods as applicable.

1. Use this method to install the flowtube to the specified fastening torque. Install the flowtube as shown in Figure 29. The torque level for tightening the bolts is not related to the gasket material. See Table 3 for the appropriate torque. For the internal diameter of the gaskets, see Table 4.

! CAUTION

The use of rubber gaskets and a lower fastening torque may result in insufficient surface pressure between the lining and the grounding ring, resulting in leakage.

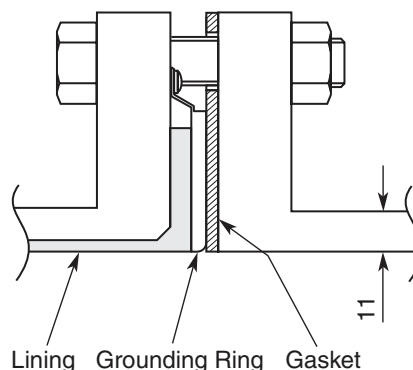

Figure 29. Installation on PVC Pipe with 316 ss Grounding Ring

2. Use this method to install the flowtube using a protective plate to prevent PVC pipe from being deformed or damaged when the bolts are tightened to the specified torque.

Install the protective plate between the outer side of the PVC flange and the flowtube, as shown in Figure 30. The protective plate protects the PVC pipe from deformation or damage when secured at the specified torque. The torque level is unrelated to the pipe or grounding ring material. See Table 7 for the appropriate torque. For the internal diameters of the gaskets, see Table 8.

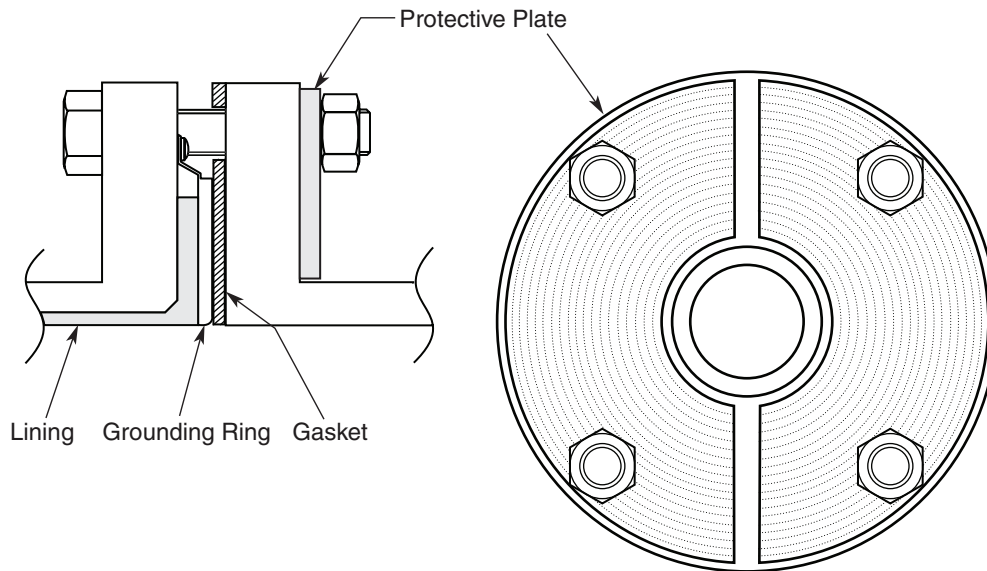

Figure 30. Installation on PVC Pipe with 316 ss Grounding Ring (with Protective Plate)

- Use this method to install the flowtube using a low-fastening torque and rubber gaskets. Remove the grounding ring from the flowtube, insert a rubber gasket 0.5 to 1.0 mm thick between the lining and the grounding ring, then reinsert the grounding ring. Then remove the PTFE gasket, and attach a gasket 3 to 4 mm thick instead. Under these conditions, attach the flowtube to the pipe as shown in Figure 31. Fasten the bolts to a torque that provides a leakproof joint.

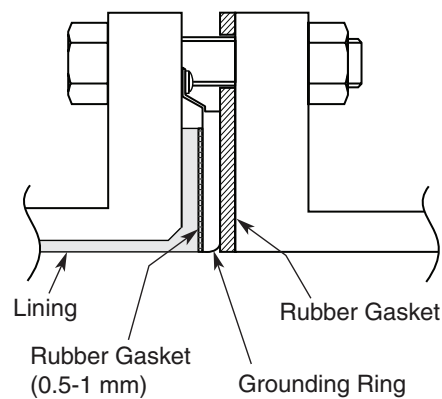

Figure 31. Installation on PVC Pipe with 316 ss Grounding Ring (with Rubber Gasket)

Installation on PVC Pipe with non-316 ss Grounding Ring

The installation procedure varies depending on conditions such as the fastening torque and the need for a protective plate (user supplied). Choose one of the following three methods as applicable.

1. Use this method to install the flowtube to the specified fastening torque. Install the flowtube as shown in Figure 32. See Table 7 for the appropriate fastening torque. For dimensions of the rubber gaskets, refer to Tables 5 and 6.

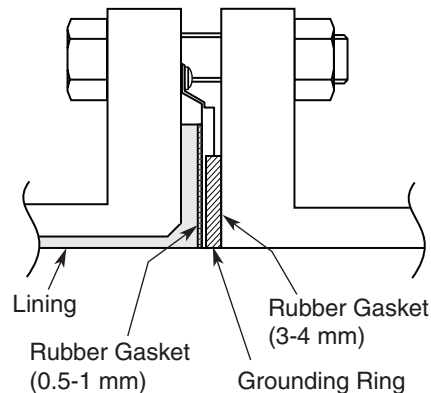

Figure 32. Installation on PVC Pipe with non-316 ss Grounding Ring

2. Use this method to install the flowtube along with a protective plate to prevent PVC pipe from being deformed or damaged when the bolts are tightened to the specified torque. Insert a protective plate between the outer side of the PVC flange and the flowtube as shown in Figure 33. The protective plate protects the PVC pipe from deformation or damage when it is secured to the specified torque. For the appropriate torque, see Table 7.

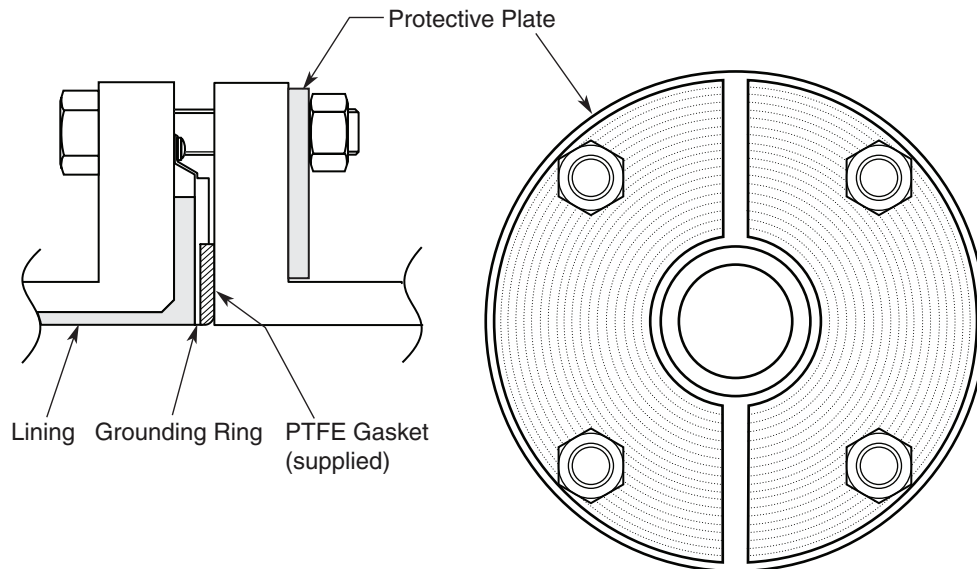

Figure 33. Installation on PVC Pipe with non-316 ss Grounding Ring (with Protective Plate)

- Use this method to install the flowtube using a low fastening torque and rubber gaskets. First, remove the grounding ring from the flowtube, then insert a rubber gasket with a thickness of 0.5 to 1.0 mm. Then reinsert the grounding ring on top of the rubber gasket. Next, remove the PTFE gasket and insert a rubber gasket 3.0 to 4.0 mm thick to replace it. Under these conditions, install the flowtube on the pipe as shown in Figure 34. Tighten the bolts to the torque required to achieve a fluid seal for the rubber gasket. In this case, the two kinds of rubber gaskets that are used should be made of the same material. For the dimensions of the rubber gaskets, refer to Tables 5 and 6.

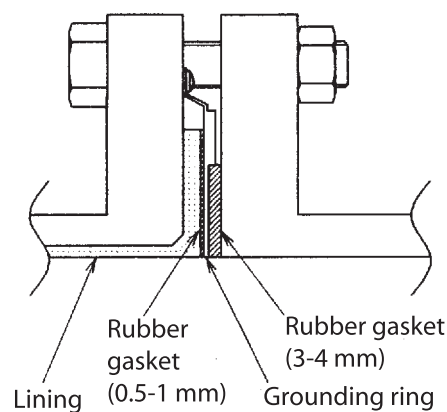

Figure 34. Installation on PVC Pipe with non-316 ss Grounding Ring (with Rubber Gaskets)

Installing a Remote-Type Transmitter

There are two methods of installation of the remote type transmitter; surface mounting, and 2-inch pipe mounting.

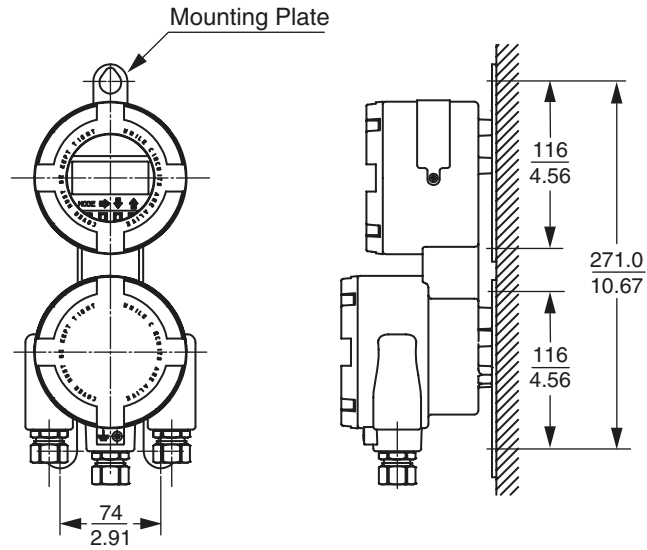

Figure 35. Surface Mounting of Transmitter

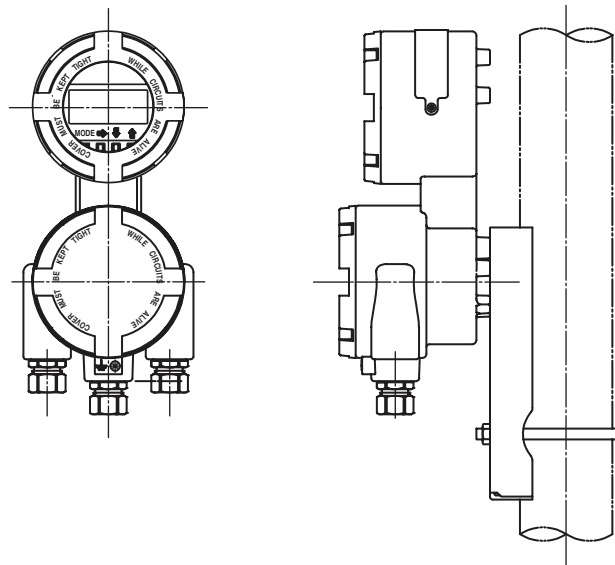

Figure 36. Pipe Mounting of Transmitter

Wiring

The installation and wiring of your flowmeter must conform to local code requirements.

Field Terminals

The terminal block of an integrally mounted transmitter is different than that of a remotely mounted transmitter.

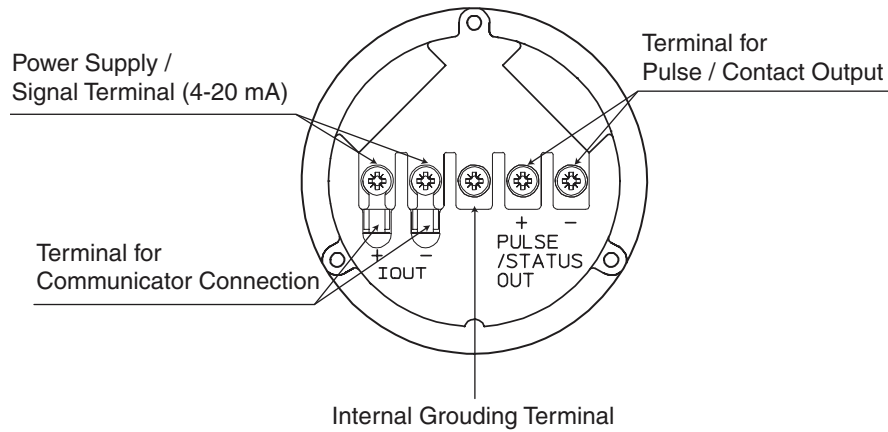

Figure 37. Terminal Block - Integral Type Transmitter

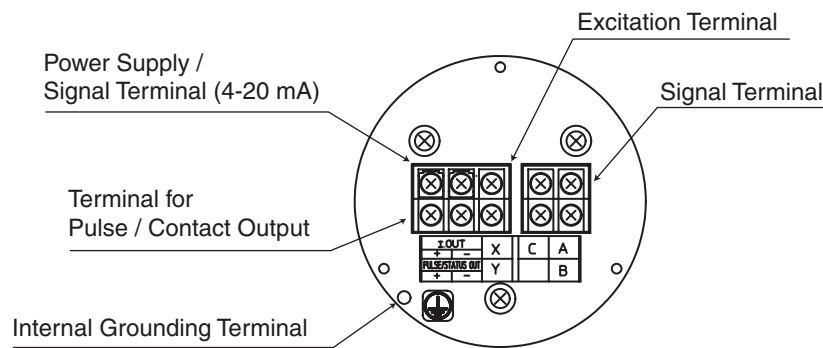

Figure 38. Terminal Block - Remote Type Transmitter

Wiring Your Transmitter

The supply voltage and loop load must be within specified limits. See Figure 39.

⚠ CAUTION

50 V dc or greater or 35 V ac or greater causes unrecoverable damage to the instrument.

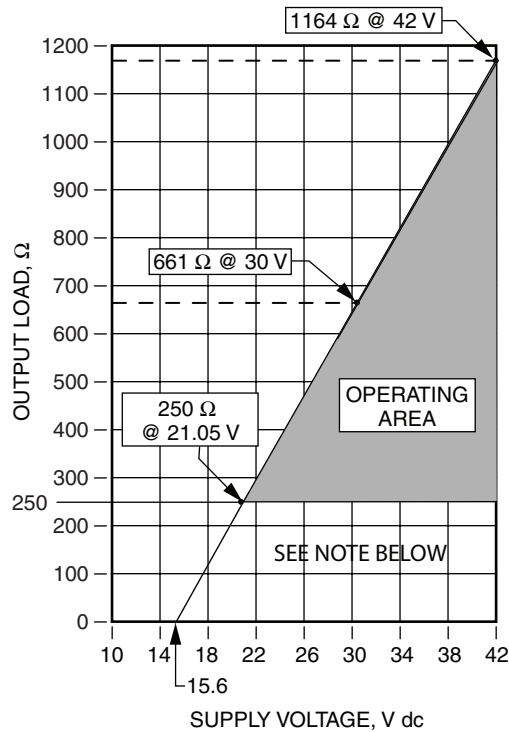

NOTE

A load resistance of 250 ohms or more is required for communications with a HART Communicator or PC-Based Configurator.

Figure 39. Supply Voltage vs Loop Load

Cabling

For the electrical cable, we recommend 600 V vinyl insulation, vinyl sheath wire CVV with 24 AWG or larger wire.

To avoid influences or damages due to electromagnetic induction, we recommend using two core shielded cables for wiring.

Select a sheath material that can endure the environment (ambient temperature, corrosive gas, corrosive fluid and so forth) in which the cable is running.

The cable is wired in to the terminal box through a conduit cable ground (with British Standard G1/2 internal thread, CM20 (M20) internal thread, or 1/2 NPT internal thread). Therefore, the optimum cable external diameter is 11 mm (7/16 in).

For the terminal treatment of the cable, we recommend a crimp terminal (metric M4 screw) with an insulating sleeve.

The maximum length of wiring cable is 1500 m (5000 ft).

When running a cable between the instrument and a controller, pay attention to the following caution:

! CAUTION

1. For waterproofing and damage prevention of the wire, we recommend using conduits and ducts. However, do **not** put the cable in the same tray or duct with other power cables. Use a waterproof gland at the conduit cable ground.
 2. The cabling should avoid a large-capacity transformer, motor, power source or other noise source.
-

Grounding

The grounding is essential for flow measurement. The most effective grounding method is direct connection to earth ground with minimal impedance. For the grounding terminal, carry out grounding work (grounding resistance 100 Ω or less) according to Figures 40 or 41. Do not ground internal and external at the same time.

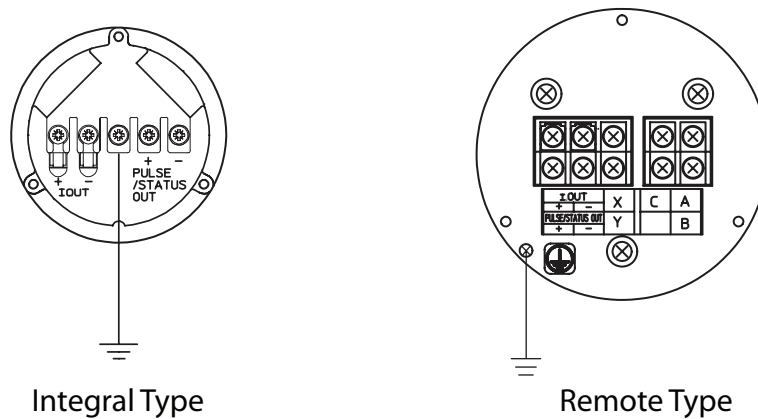

Figure 40. Grounding Using Internal Grounding Terminal

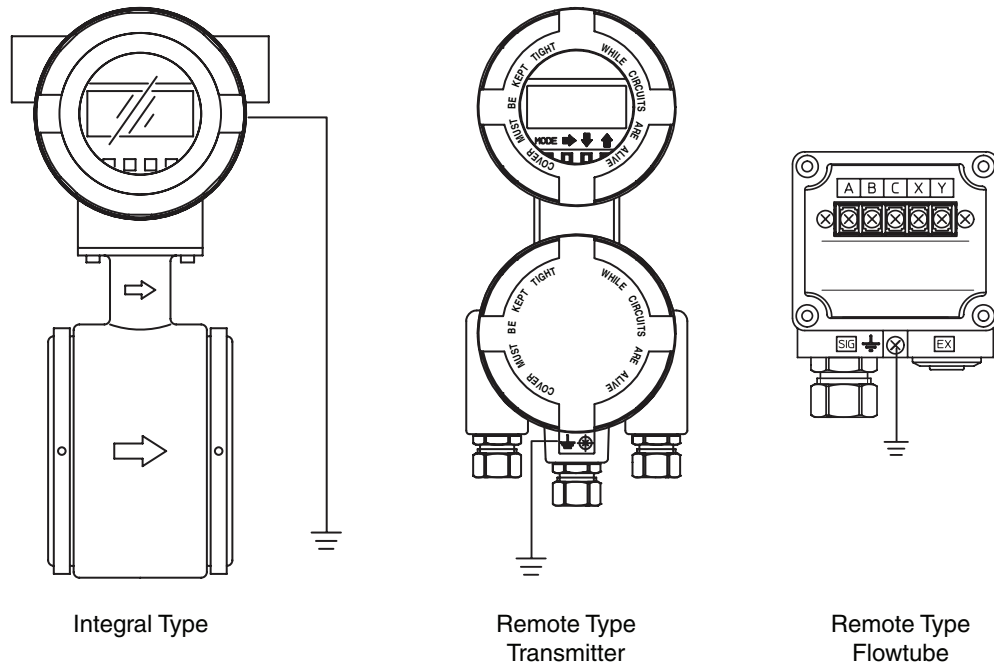

Figure 41. Grounding Using External Grounding Terminal

Wiring Connection of Power Supply and Analog Output

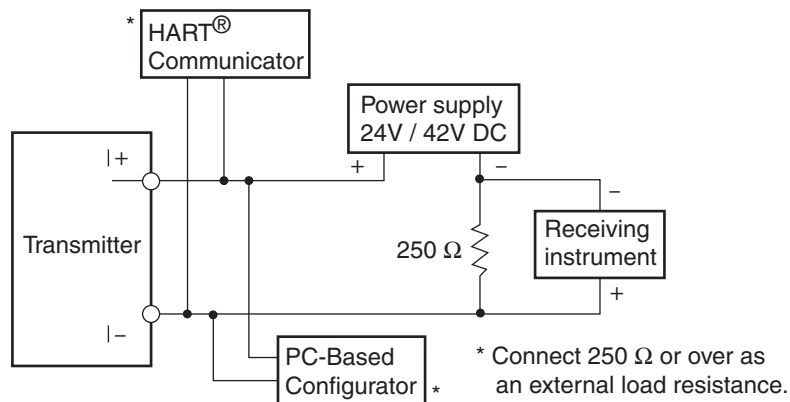

Figure 42. Wiring Connection Diagram

Input Circuit Such As Sequence Controllers

It must use 4-20 mA such as sequence (programmable) controllers and the input to the equipment with A/D at high speed must use the following optional circuits.

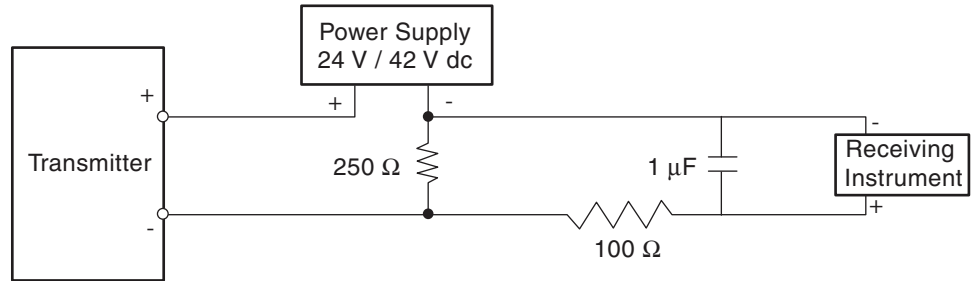

Figure 43. Wiring Connection Diagram (when inputting to a sequence controller)

CAUTION
 Incorrect wiring polarity can cause damage to the equipment. Double-check the wiring position.

Wiring Connection for Pulse Output

The pulse output is an open-collector output. Carry out the wiring paying attention to the voltage and polarity.

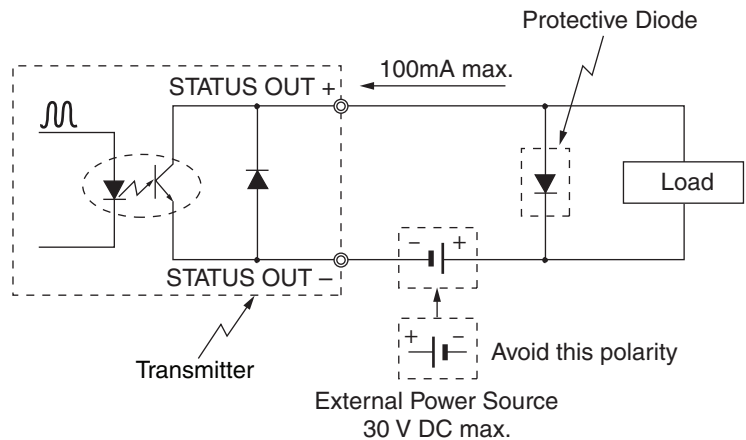
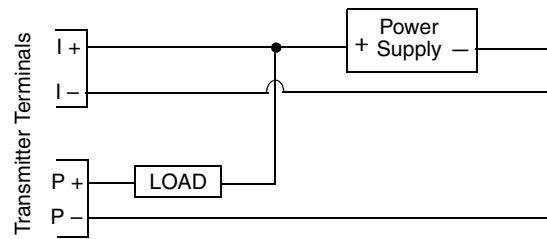

Figure 44. Pulse Output Wire Connection Diagram

Wiring Connection for Analog and Pulse Output

When wiring for an analog and pulse output from a single power supply, the minimum voltage is per Figure 39 and the maximum voltage is 30 V dc.



Power Supply Current Must Be >20 mA

Figure 45. Analog and Pulse Outputs from Single Power Supply

Wiring Connection for Contact Output

Because of an open-collector output, carry out wiring paying attention to the polarity.

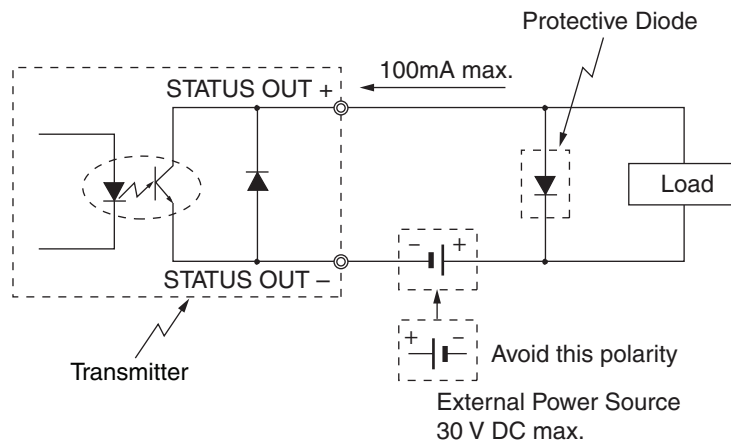

Figure 46. Contact Output Wiring Connection Diagram

Wiring Procedure

Carry out the wiring between the instrument and a power supply must be done according to the following procedure:

Step	Procedure
1	The terminal box cover is secured by hexagon socket head set screws (M3). Loosen the set screws with a hex head wrench.
2	Remove the terminal box cover by turning it counterclockwise.
3	Remove the dust plug from the socket for an output signal line conduit.
4	Insert the cable into the conduit cable ground. <i>Note: Take care not to damage the cable sheath.</i>

Step	Procedure
5	Referring to Figure 42, connect the cable to the output signal terminals (IOUT+, -) of the terminal box. <i>Note: Pay attention to the polarity.</i> <i>Tighten the terminal screws adequately. The recommended tightening torque is 1.1 ft·lb (1.5 N·m).</i>
6	Waterproof the conduit sufficiently to prevent ingress of rainwater, etc. <i>Note: We recommend using a silicon resin-based non-curing sealant.</i>
7	Attach the terminal box cover and tighten it adequately. Then, secure the cover with the set screws.

Wiring the Power Supply

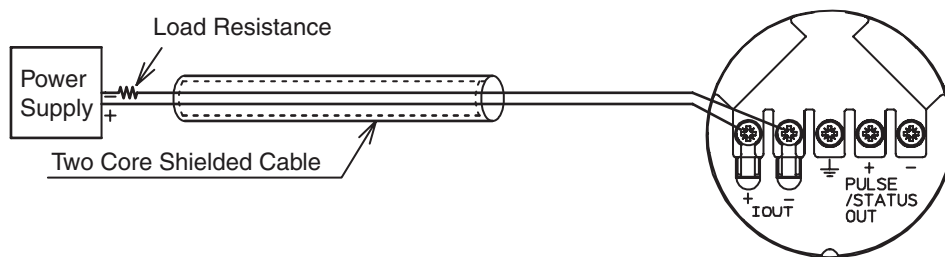

Figure 47. Power Supply Wiring - Integral Type

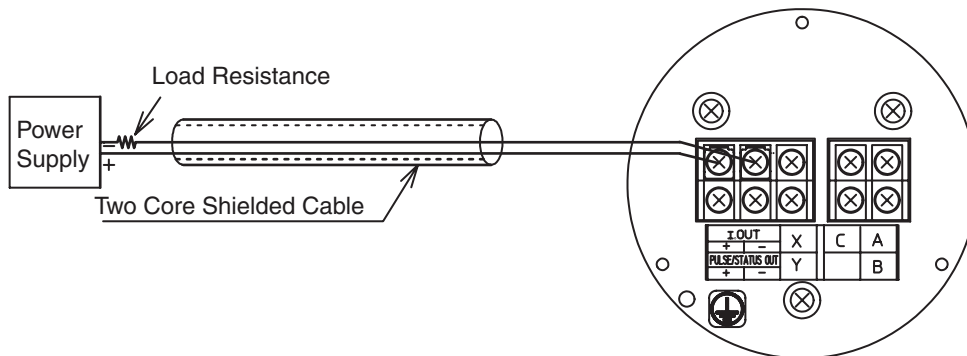

Figure 48. Power Supply Wiring - Remote Type

Wiring Connection Between Flowtube and Transmitter

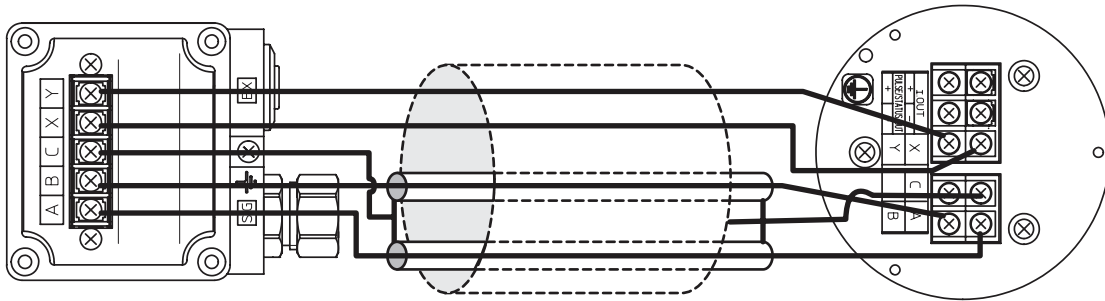

Figure 49. Wiring Connection between Flowtube and Transmitter

Use supplied cable for wiring connection between flowtube and transmitter.

Wiring Diagram for FM Nonincendive Installations

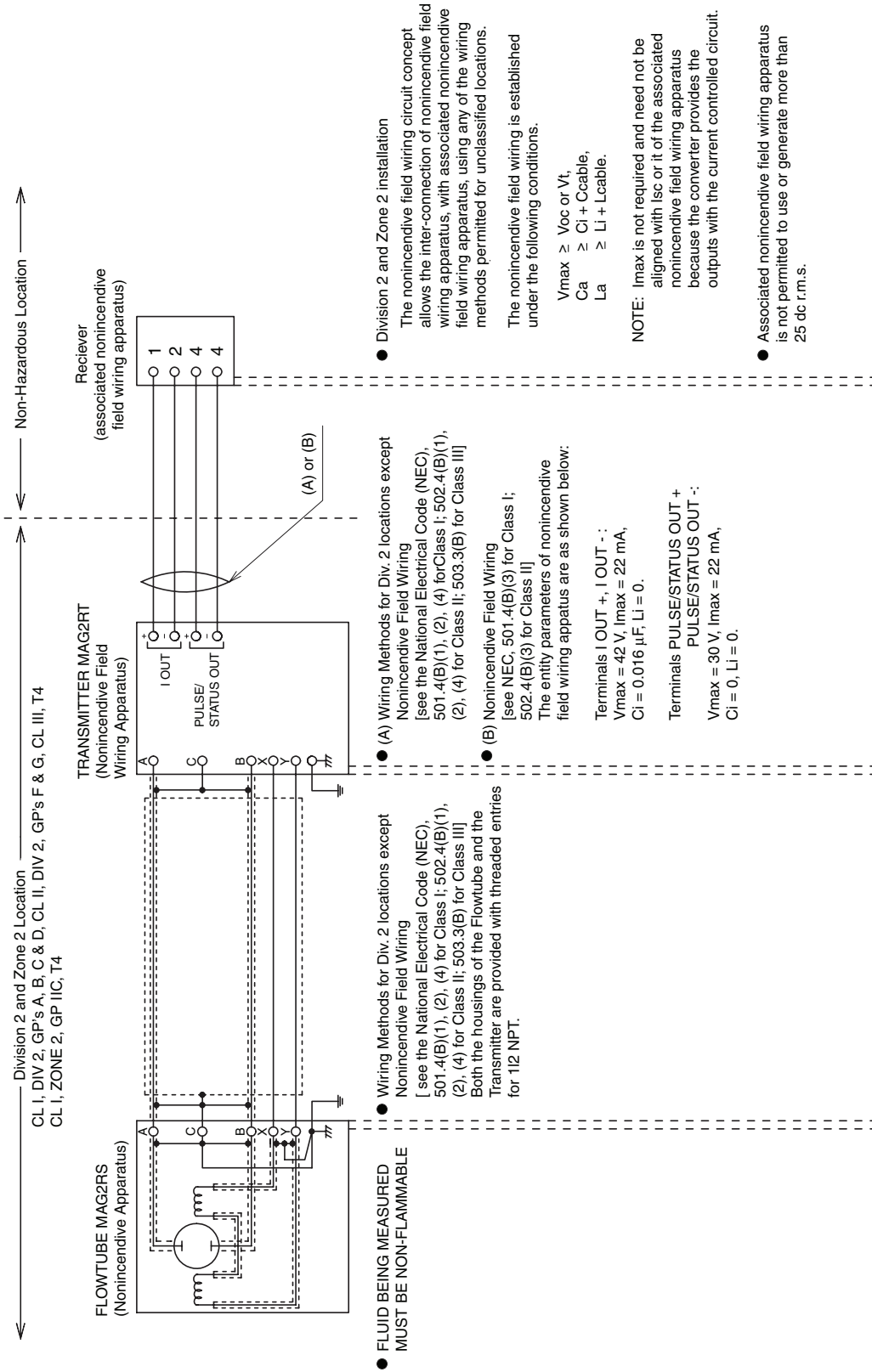

Figure 50. Wiring Diagram for FM Certified Nonincendive Installations

3. Start-Up and Shutdown

This chapter describes the procedure for start-up of the instrument and making a zero adjustment. It also describes the shutdown of the measuring system.

When starting up and operating the instrument for the first time, carefully follow the descriptions in this chapter.

Start-Up

Before you start up the instrument, perform the following:

1. Confirm that the electromagnetic flowmeter is installed correctly in the pipes.
2. Confirm that the electrical wiring is correct.
3. If communication is required, confirm that the communication equipment is wired correctly.
4. Fill the flowtube with a fluid and perform zero adjustment in a static state.
5. Confirm that there is no leakage at the flowtube.
6. Confirm that the flowtube is filled with water and there are no stagnant bubbles.
7. Turn on power and warm up for 30 minutes.
8. Confirm whether the settings of the data sheet inserted in the transmitter have been setup and configured.
9. For the accurate flow measurement, verify the zero point value in each excitation current (Manual zero1, manual zero2, and manual zero3) by using manual zero function, if the normal flow velocity is less than 0.3 m/s (0.98 ft/s).

— **NOTE** —

1. If the flowtube is not filled with water or many bubbles have adhered inside, the indication may not reach zero flow rate. In such cases, make a flow of water once to ensure that the flowtube is free of bubbles and filled with water.
 2. With incorrect grounding, the indication of flow rate may fluctuate largely. In such cases, check the grounding condition.
 3. Once you change the flow rate range, perform auto zero adjustment.
-

Shutdown

—  **CAUTION** —

When stopping the instrument from operation and shutting down the output to control equipment, always change the control to manual control. This prevents the shutdown from directly influencing the control equipment.

When shutting down the instrument, follow the following procedure:

Step	Procedure
1	Change the control of the transmitter from automatic to manual control.
2	Turn off power to the transmitter.

4. Operation Via Local Display

Startup Displays

All settings can be configured from the local display.

When the power supply is turned on, the display changes in the order of OVERALL DISPLAY, SELF CHECK MODE, and MEASURING MODE.

OVERALL DISPLAY

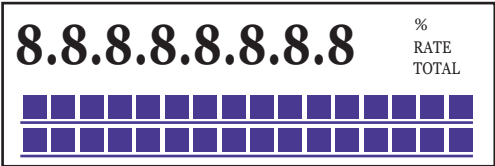

8.8.8.8.8.8.8.8
Main display: 7-segment, 8-digit display
% flow rate Actual flow rate Integration value
■■■■■■■ Unit display
■ Sub-display Display screen for setting
Displayed for 2 seconds.



SELF CHECK MODE



Main display 7-segment, 8-digit blinks.
The display (-) moves from left to right.
Sub display: SELF CHECK MODE
Displayed for 5 seconds



MEASURING MODE

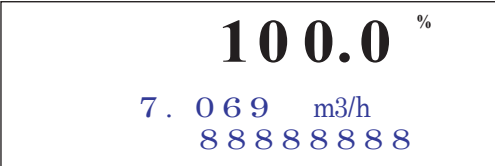

Names and Descriptions of Parts

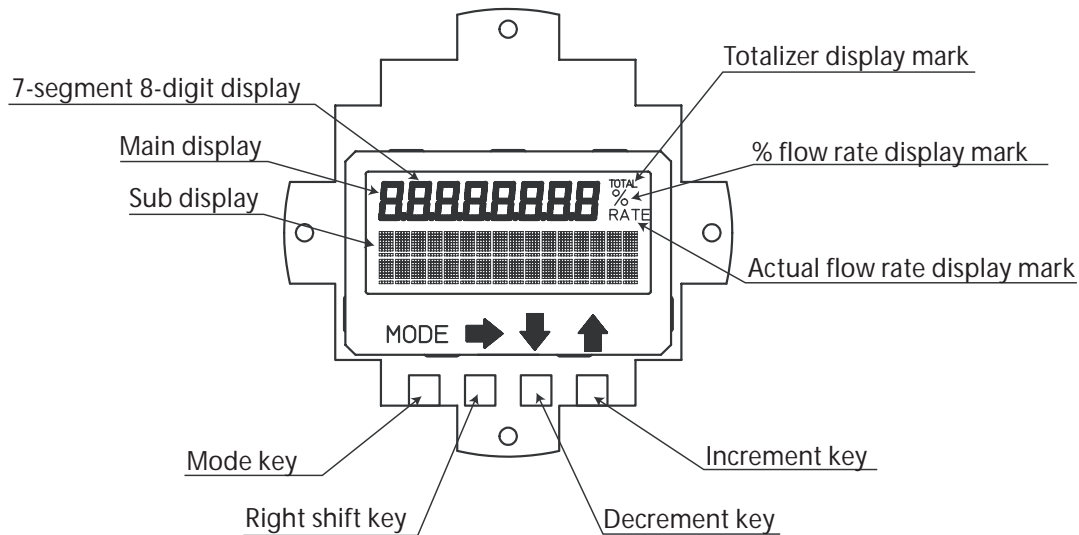

Figure 51. Local Display Parts

Displays

The flow rate display is given at three stages: % flow rate, actual flow rate and totalized value. Operating the key, the main display to be shown at the top stage can be set selecting from the actual flow rate, % flow rate and totalized value. **RATE** appears for the actual flow rate display, **%** for the % flow rate display, and **TOTAL** for the totalized value display (see “Display Overview” on page 57.)

Area	Description
Main display 7-segment 8-digit display	Displays the flow rate display selected for the main display by DISP SELECT in OPERATOR'S MODE.
% flow rate display mark (%)	Displays when % flow rate is shown for the main display.
Actual flow rate display mark (RATE)	Displays when the actual flow rate is shown for the main display.
Totalized value display mark (TOTAL)	Displays when the totalized value is shown for the main display.
Sub display	<ul style="list-style-type: none"> • In MEASURING MODE, shows a flow rate display other than a flow rate display selected for the main display by DISP SELECT in OPERATOR'S MODE. • In modes other than MEASURING MODE, indicate procedures for setting and adjusting parameters.

Keys

Name	Description
MODE key	<ul style="list-style-type: none"> Enters OPERATOR’S MODE. When parameters and configured data have been changed in ENGINEERING MODE or MAINTENANCE MODE, press this key to save the data.
Right shift key	<ul style="list-style-type: none"> Moves the cursor to the right.
Decrement key	<ul style="list-style-type: none"> Changes the parameter at a cursor position. Displays the previous screen. <div data-bbox="743 747 1089 873" style="border: 1px solid black; padding: 5px; margin-bottom: 10px;"> <p>* OPERATOR'S MODE</p> <p style="text-align: right;">MODE</p> <p>Cursor</p> </div> <p data-bbox="1105 730 1455 873">If the key is pressed, when the cursor is placed at the upper left end (*, #, >), the screen changes.</p> <div data-bbox="743 932 1089 1058" style="border: 1px solid black; padding: 5px; margin-bottom: 10px;"> <p>* DAMPING</p> <p style="text-align: right;">001.0 S</p> <p>Cursor</p> </div> <p data-bbox="1105 915 1455 1058">If the key is pressed, when the cursor is placed at a number, the number is decremented.</p> <div data-bbox="743 1117 1089 1243" style="border: 1px solid black; padding: 5px;"> <p># 1.0000 m/s</p> <p>SPAN 07.069 m³/h</p> <p>Cursor</p> </div> <p data-bbox="1105 1100 1455 1201">If the cursor is placed at a decimal point, the decimal point moves rightward.</p>

Name	Description
Increment key	<ul style="list-style-type: none"> • Changes the parameter at a cursor position. • Displays the following screen. <div style="display: flex; justify-content: space-between;"> <div style="border: 1px solid black; padding: 5px; width: 40%;"> <p>* OPERATOR'S MODE</p> <p>Cursor</p> </div> <div style="width: 55%;"> <p>If the key is pressed, when the cursor is placed at the upper left end (*, #, >), the screen changes.</p> </div> </div> <div style="display: flex; justify-content: space-between; margin-top: 10px;"> <div style="border: 1px solid black; padding: 5px; width: 40%;"> <p>* DAMPING</p> <p>001.0 S</p> <p>Cursor</p> </div> <div style="width: 55%;"> <p>If the key is pressed, when the cursor is placed at a number, the number is incremented.</p> </div> </div> <div style="display: flex; justify-content: space-between; margin-top: 10px;"> <div style="border: 1px solid black; padding: 5px; width: 40%;"> <p># 1.0000 m/s</p> <p>SPAN 07.069 m³/h</p> <p>Cursor</p> </div> <div style="width: 55%;"> <p>If the key is pressed, when the cursor is placed at a decimal point, the decimal point moves to the left.</p> </div> </div> <div style="display: flex; justify-content: space-between; margin-top: 10px;"> <div style="border: 1px solid black; padding: 5px; width: 40%;"> <p>* AUTO ZERO</p> <p>READY</p> <p>Cursor</p> </div> <div style="width: 55%;"> <p>If the cursor is placed over READY, pressing the key starts operation.</p> </div> </div>

Write Protection

Table 9. Write Protection Level Operating Conditions

Write Protect Level	SW1	SW2	LSC (Key operation)			Communication		
			OPERATOR'S MODE	ENGINEERING MODE	MAINTENANCE MODE	OPERATOR'S MODE	ENGINEERING MODE	MAINTENANCE MODE
0	OFF	OFF	R/W ENABLE	R/W ENABLE	R/W ENABLE	R/W ENABLE	R/W ENABLE	R/W ENABLE
1	ON	OFF	R/W ENABLE	R/W ENABLE	R/W ENABLE	R ONLY	R ONLY	R ONLY
2	OFF	ON	R/W ENABLE	R ONLY	R/W ENABLE	R ONLY	R ONLY	R ONLY
3	ON	ON	R ONLY	R ONLY	R/W ENABLE	R ONLY	R ONLY	R ONLY

R/W: Read and Write (Reads and writes set values.)

R: Read

ENABLE: Enabled

DISABLE: Disabled

ONLY: Only the indicated operation is enabled.

— **NOTE** —

Be sure to turn off the power supply before changing the write protect level dip switch settings.

Table 10. Write Protection Switch Settings

Switch Number	Setting At Shipment
S1	Determined by WP LEVEL.
S2	Determined by WP LEVEL.
S3	ON (No data change is allowed.)

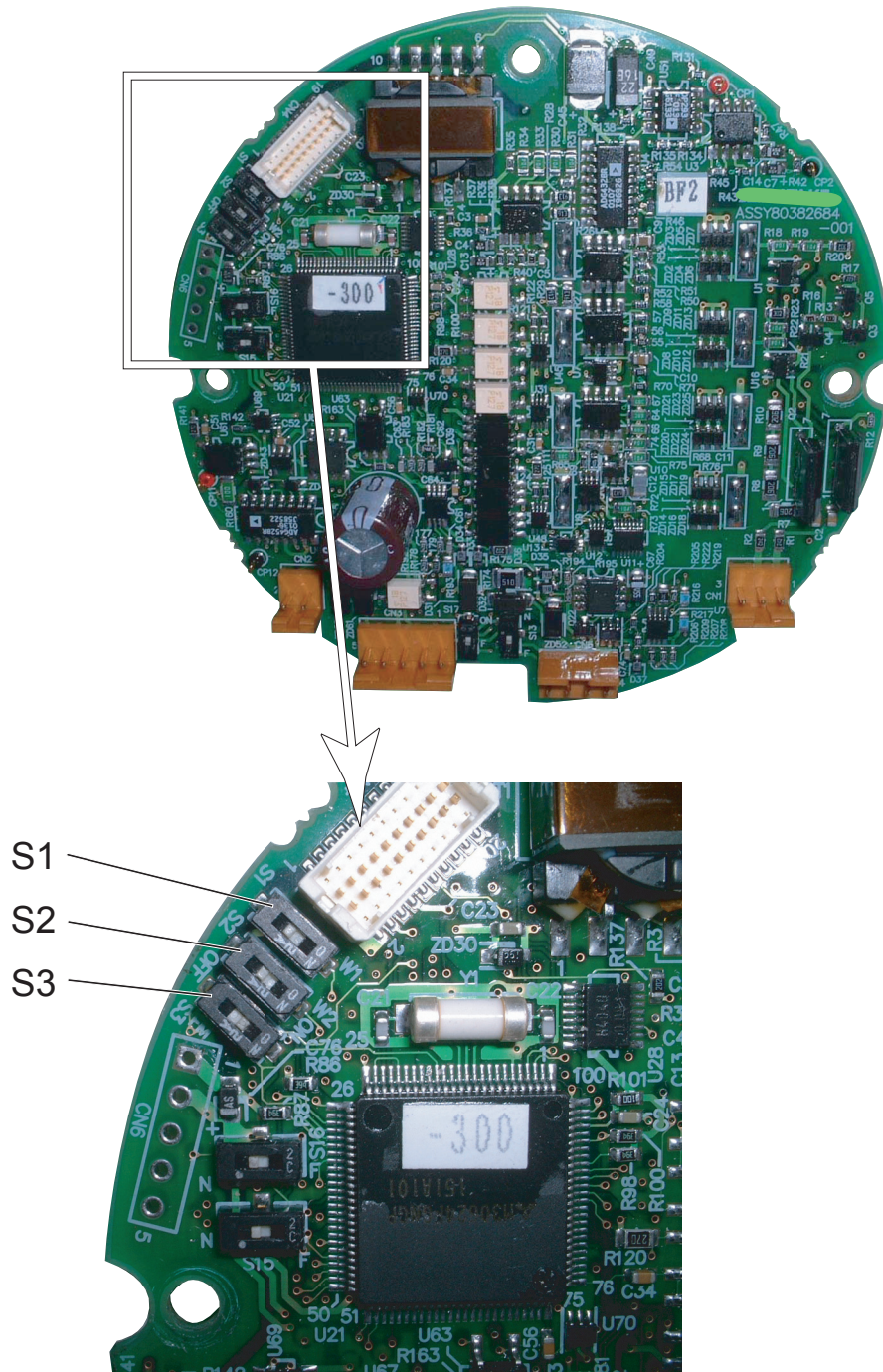
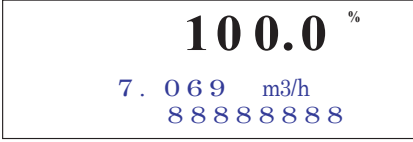
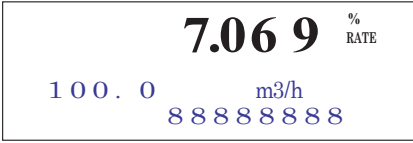
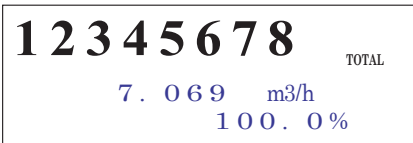

Figure 52. Location of Write Protect Switches on Main Board

Description of Measuring Mode

Display Overview

<p>% flow rate display</p> 	<p>1st line (Main display): 7-segment 4-digit display % flow rate (%)</p> <p>2nd line: Actual flow rate display (Significant value of 5 digits)</p> <p>3rd line: Totalized value display (Significant figure of 8 digits) Write protect level display (WP0 to 3)</p>
<p>Actual flow rate display</p> 	<p>1st line (Main display): 7-segment 4-digit display Actual flow rate (RATE)</p> <p>2nd line: % flow rate display (Significant figure of 4 digits), unit of actual flow rate</p> <p>3rd line: Totalized value display (Significant figure of 8 digits) Write protect level display (WP0 to 3)</p>
<p>Totalizer display</p> 	<p>1st line (Main display): 7-segment 8-digit display Totalized value (TOTAL)</p> <p>2nd line: Actual flow rate display (Significant figure of 4 digits)</p> <p>3rd line: % flow rate display (Significant figure of 4 digits) Write protect level display (WP0 to 3)</p>

Details of Display

% flow rate display: The % flow rate display range is from -115.0% to 115.0%.

A value up to the first decimal place is displayed. The position of the decimal point is fixed.

The integer part to be displayed has up to three digits (0 to 115).

In the main display, unnecessary zeros are deleted (but are not deleted in the sub display).

Example) 019.8% → 19.8%

-000.5% → -0.5%

The position of the negative sign (-) is fixed. (The positive sign is not displayed.)

Actual flow rate display: The flow rate displayed in the actual flow rate display is up to 115% of the range or the equivalent.

However, if the flow rate equivalent to 115% of the range exceeds the range of significant figure, the highest value (e.g., 9.999) is displayed.

In the main display, unnecessary zeros are deleted (but are not deleted in the sub display).

Totalized value display: An totalized value is displayed in 8 digits without signs and decimal points.

In the main display, unnecessary zeros are deleted (but are not deleted in the sub display).

Next to 99999999, totalization starts from 00000000.

— NOTE

Totalization is not performed, when the output selection is set to the contact output. However, the previous value is displayed as the totalized value.

Overview of Operation Using the Local Display

The data setting device has three types of modes: OPERATOR'S MODE, ENGINEERING MODE, and MAINTENANCE MODE. MAINTENANCE MODE is furthermore divided into three of sub-modes: OUTPUT, CALIBRATION, and CRITICAL. The screen flow is as follows:

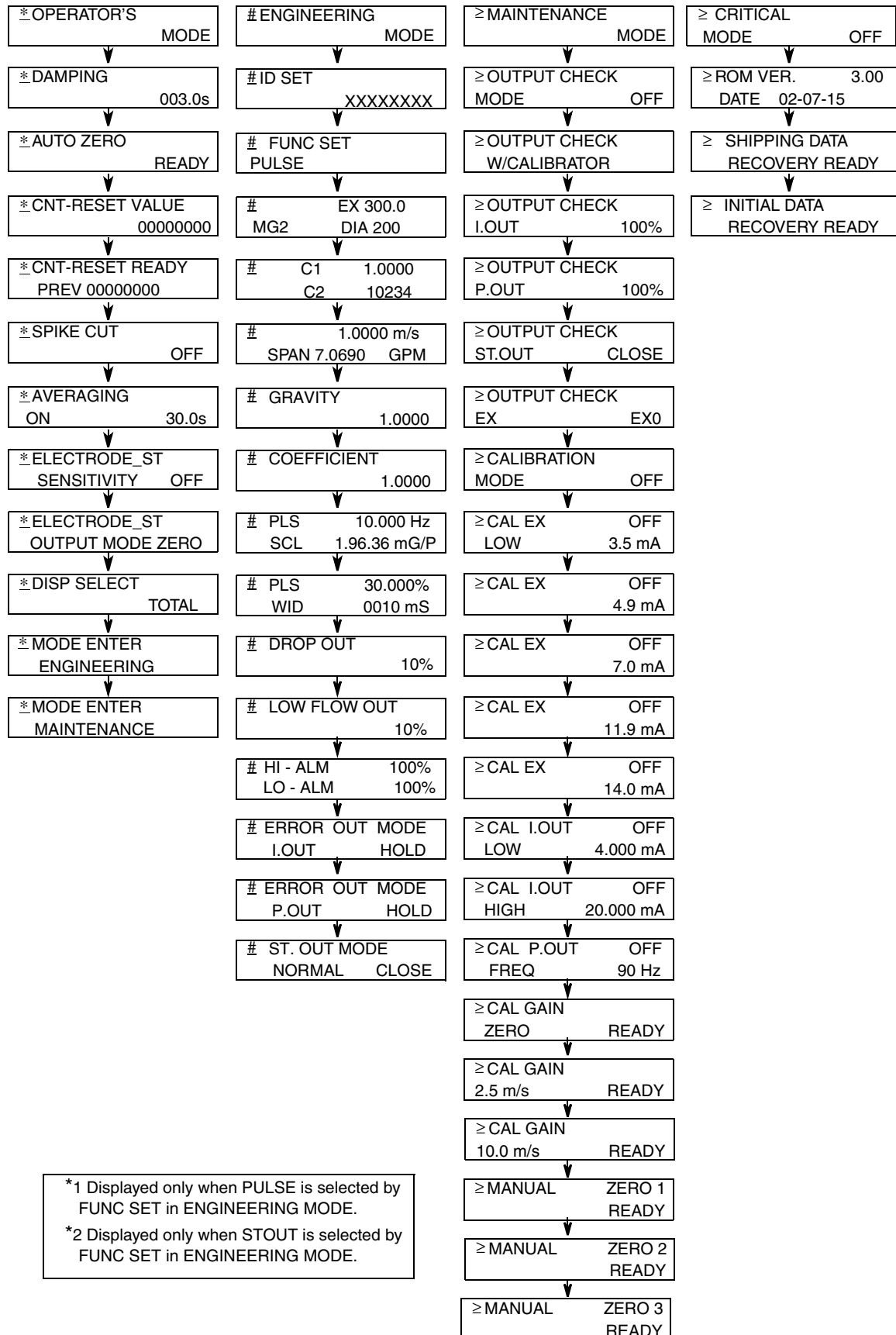

Configuration of Operator's Mode

The OPERATOR'S MODE is set for the operator. This mode is comprised of setting and configuration of data that are set or changed frequently during startup. In this mode, settings can be changed only when the write protect levels are set to 0, 1 and 2. At level 3, only the set data can be checked.

—  **CAUTION** —

Set or changed data are temporarily written into the memory. Note that if the configured data are not saved/written into the memory within 10 minutes, the configured data returns to the previous values.

—  **CAUTION** —

Be sure to press the **MODE** key to return to the MEASURING MODE and to save data.

The OPERATOR'S MODE provides the following setting and adjustment items.

Item	Contents	Screen
DAMPING	Sets a damping time constant.	<div style="border: 1px solid black; padding: 5px; text-align: right;"> 20.0 % * DAMPING 005.0 s </div>
AUTO ZERO	Auto zero adjustment	<div style="border: 1px solid black; padding: 5px; text-align: right;"> 20.0 % * AUTO ZERO READY </div>
CNT-RESET VALUE	Sets a built-in counter reset value.	<div style="border: 1px solid black; padding: 5px; text-align: right;"> 20.0 % * CNT-RESET VALUE 0 0 0 4 4 4 4 </div>
CNT-RESET READY	Resets totalized value to a built-in counter reset value.	<div style="border: 1px solid black; padding: 5px; text-align: right;"> 20.0 % * CNT-RESET READY 0 0 0 0 0 0 0 </div>
SPIKE CUT	Sets auto spike cut.	<div style="border: 1px solid black; padding: 5px; text-align: right;"> 20.0 % * SPIKE CUT OFF </div>
AVERAGING	Sets a moving average function.	<div style="border: 1px solid black; padding: 5px; text-align: right;"> 20.0 % * AVERAGING OFF </div>
ELECTRODE_ST SENSITIVITY	Sets Electrode Status Diagnostic function. Selects a sensitivity level of electrode diagnostic function.	<div style="border: 1px solid black; padding: 5px; text-align: right;"> 20.0 % * ELECTRODE_ST SENSITIVITY OFF </div>

Item	Contents	Screen
ELECTRODE_ST OUTPUT MODE	Sets output mode when the Electrode Status Diagnostic function detects the empty or scale on electrode condition.	<div style="border: 1px solid black; padding: 5px; text-align: right;"> 20.0 % * ELECTRODE_ST _ OUTPUT MODE OFF </div>
DISP SELECT	Selects either % flow rate, actual flow rate or totalized value to be displayed in the main display.	<div style="border: 1px solid black; padding: 5px; text-align: right;"> 20.0 % * DISP SELECT _ % </div>
MODE ENTER ENGINEERING	Enters the ENGINEERING MODE.	<div style="border: 1px solid black; padding: 5px; text-align: right;"> 20.0 % * MODE ENTER _ ENGINEERING </div>
MODE ENTER MAINTENANCE	Enters the MAINTENANCE MODE.	<div style="border: 1px solid black; padding: 5px; text-align: right;"> 20.0 % * MODE ENTER _ MAINTENANCE </div>

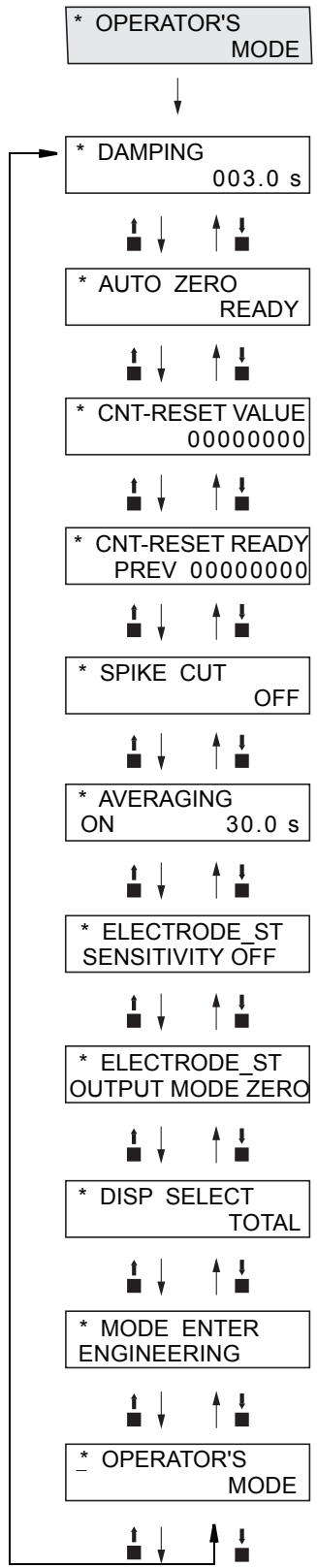

Figure 53. Operator's Mode Menu Tree

Changing Setting of Damping Time Constant

Damping means a response time of the primary time lag (63.2% response) for a step response of the flow rate. If the out fluctuations are large, increase the damping. A large damping value stabilizes the output but lowers the response performance. We suggest setting the damping to the largest value the system can accept.

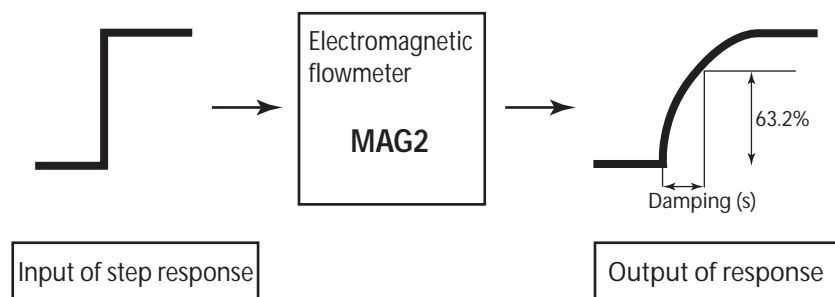

Figure 54. Damping Output Characteristics

Set the damping time constant in accordance with the following procedure:

— CAUTION —

You have only ten minutes to return to MEASURING MODE to save the new value before the system resets it to the previously saved value.

Step	Procedure	Screen
1	The screen at right is a screen display example in MEASURING MODE (measurement state). Press the MODE key.	<pre> 20.0 % 01.94 m³/h WPO 00069401 </pre>
2	The OPERATOR'S MODE screen appears for approximately two seconds and then the damping setting screen appears.	<pre> 20.0 % * OPERATOR'S _ MODE 20.0 % * DAMPING _ 005.0 s </pre>
3	Press the → key until the cursor is at the value to be changed. In this example, the key is pressed three times to move to the position "5."	<pre> 20.0 % * DAMPING _ 005.0 s </pre>
4	Press the ↑ or ↓ key to display a time constant to be changed. In this example, the ↑ key is pressed five times to change the damping time from 5 seconds to 10 seconds.	<pre> 20.0 % * DAMPING _ 005.0 s </pre>

Step	Procedure	Screen
5	Press the → key until the cursor is back at the mode indicator. Press the MODE key to return to the MEASURING MODE and to save data.	<div style="border: 1px solid black; padding: 5px; width: fit-content;"> <div style="text-align: right;">20.0 %</div> * DAMPING <div style="text-align: right;">005.0 s</div> </div>

Auto Zero Adjustment

Auto zero must be carried out only under the condition when the flowtube is filled with process fluid at zero flow. Run this function only after installing the electromagnetic flowmeter to the process pipe. Performing this function under a condition where the process fluid is not at zero flow may cause measurement errors.

Set range: None in particular

Default: None in particular

— NOTE —

The zero adjustment takes approximately two minutes. During the zero adjustment, the output of analog current may rise to approximately 9 mA in some cases. This is not abnormal. To carry out the zero adjustment, set the control loop to manual.

Make the auto zero adjustment in accordance with the following procedure:

— ⚠ CAUTION —

You have only ten minutes to return to MEASURING MODE to save the new value before the system resets it to the previously saved value.

Step	Procedure	Screen
1	The screen at right is a screen display example in MEASURING MODE (measurement state). Press the MODE key.	<div style="border: 1px solid black; padding: 5px; width: fit-content;"> <div style="text-align: right;">1.0 %</div> 01.94 m³/h 00069401 </div>
2	The OPERATOR'S MODE screen appears for approximately two seconds and then the damping setting screen appears.	<div style="border: 1px solid black; padding: 5px; width: fit-content;"> <div style="text-align: right;">1.0 %</div> * OPERATOR'S MODE <hr/> <div style="text-align: right;">1.0 %</div> * DAMPING 005.0 s </div>
3	Press the ↑ key once to display the screen as shown.	<div style="border: 1px solid black; padding: 5px; width: fit-content;"> <div style="text-align: right;">0.0 %</div> * AUTO ZERO READY </div>
4	Press the → key to move the cursor to the position READY .	<div style="border: 1px solid black; padding: 5px; width: fit-content;"> <div style="text-align: right;">0.0 %</div> * AUTO ZERO <u>READY</u> </div>

Step	Procedure	Screen
5	Press the ↑ key to start the auto zero adjustment. If the main display selects % flowrate, the display of 0.0 blinks during adjustment. With the adjustment completed, the display stops blinking with ON switched to READY . This zero adjustment takes about two minutes.	<div style="border: 1px solid black; padding: 5px; margin-bottom: 5px;"> <div style="text-align: right;">0.0 %</div> * AUTO ZERO <div style="text-align: center;">ON</div> </div> <div style="border: 1px solid black; padding: 5px;"> <div style="text-align: right;">0.0 %</div> * AUTO ZERO <div style="text-align: center;">READY</div> </div>
6	Press the → key to move the cursor to the position under *. Press the MODE key to return to the MEASURING MODE and save data.	<div style="border: 1px solid black; padding: 5px;"> <div style="text-align: right;">0.0 %</div> * AUTO ZERO <div style="text-align: center;">READY</div> </div>

Setting the Built-in Counter Reset Value

Set a start value of the built-in counter. The scale of this value is considered as the weight of the pulse. Reset the built-in counter described in the next section to start totalization from any totalized value.

Set range:00000000 - 99999999

Default:00000000

Set an internal counter reset value in accordance with the following procedure:

— CAUTION —

You have only ten minutes to return to MEASURING MODE to save the new value before the system resets it to the previously saved value.

Step	Procedure	Screen
1	The screen at the right is a screen display example in MEASURING MODE (measurement state). Press the MODE key.	<div style="border: 1px solid black; padding: 5px;"> <div style="text-align: right;">20.0 %</div> <div style="text-align: right;">01.94 m³/h</div> WPO 00069401 </div>
2	The OPERATOR'S MODE screen appears for approximately two seconds and then the damping setting screen appears.	<div style="border: 1px solid black; padding: 5px; margin-bottom: 5px;"> <div style="text-align: right;">20.0 %</div> * OPERATOR'S <div style="text-align: center;">MODE</div> </div> <div style="border: 1px solid black; padding: 5px;"> <div style="text-align: right;">20.0 %</div> * DAMPING <div style="text-align: right;">005.0 s</div> </div>
3	Press the ↑ key twice to display the screen.	<div style="border: 1px solid black; padding: 5px;"> <div style="text-align: right;">20.0 %</div> * CNT-RESET VALUE <div style="text-align: right;">00044444</div> </div>

Step	Procedure	Screen
4	Press the → key to move the cursor to the position under a target value to be changed.	<div style="border: 1px solid black; padding: 5px; width: fit-content;"> <div style="text-align: right;">20.0 %</div> * CNT-RESET VALUE <div style="text-align: right;">0000<u>0</u>000</div> </div>
5	Press the ↑ or ↓ key to set a desired value.	<div style="border: 1px solid black; padding: 5px; width: fit-content;"> <div style="text-align: right;">20.0 %</div> * CNT-RESET VALUE <div style="text-align: right;">0000<u>5</u>000</div> </div>
6	Press the → key to move the cursor to the position under *. Press the MDOE key to return to the MEASURING MODE and to save data.	<div style="border: 1px solid black; padding: 5px; width: fit-content;"> <div style="text-align: right;">20.0 %</div> _ CNT-RESET VALUE <div style="text-align: right;">00005000</div> </div>

Resetting the Built-In Counter

Reset the built-in counter to start totalization from a value set as the built-in counter reset value. If this value is set to 1000, the built-in counter starts totalization from 1000 after the counter is completely reset.

If the built-in counter is reset, the built-in counter value just before the reset appears at the side of PREV on the LCD display.

Set range:None

Default:None

Reset the internal counter in accordance with the following procedure:

—! CAUTION —

You have only ten minutes to return to MEASURING MODE to save the new value before the system resets it to the previously saved value.

Step	Procedure	Screen
1	The screen at the right is a screen display example in MEASURING MODE (measurement state). Press the MODE key.	<div style="border: 1px solid black; padding: 5px; width: fit-content;"> <div style="text-align: right;">20.0 %</div> 01.94 m³/h WPO 00069401 </div>
2	The OPERATOR'S MODE screen appears for approximately two seconds and then the damping setting screen appears.	<div style="border: 1px solid black; padding: 5px; width: fit-content;"> <div style="text-align: right;">20.0 %</div> _ OPERATOR'S MODE </div> <div style="border: 1px solid black; padding: 5px; width: fit-content;"> <div style="text-align: right;">20.0 %</div> _ DAMPING 005.0 s </div>

Step	Procedure	Screen
3	Press the ↑ key three times to display the screen shown on the right.	<pre> 20.0 % * CNT-RESET READY PREV 00000000 </pre>
4	Press the → key to move the cursor to the position READY .	<pre> 20.0 % * CNT-RESET <u>READY</u> PREV 00000000 </pre>
5	Press the ↑ key to reset. In 0.5 seconds, the reset is completed with ON changing to READY .	<pre> 20.0 % * CNT-RESET <u>ON</u> PREV 00000000 </pre> <pre> 20.0 % * CNT-RESET <u>READY</u> PREV 00123456 </pre>
6	Press the → key to move the cursor to the position under *. Press the MODE key to return to the MEASURING MODE and save data.	<pre> 20.0 % * <u>CNT-RESET</u> READY PREV 00123456 </pre>

Setting Auto Spike Cut

This function eliminates steep noise spikes (spike noise) in the flow rate. Noise generated when foreign matters collide with electrode is an example of the spike noise.

When the flow rate changes sharply, this function holds the outputs according to the damping time. Generally the spike noise occurs in a few milliseconds and settles down within the output holding time and the outputs are not affected. For ordinary flowrate changes, the output responds after the damping hold time.

It is not recommended to use this function for applications requiring high response and performance; for example, the function should not be used when a pump frequently generates pulsation.

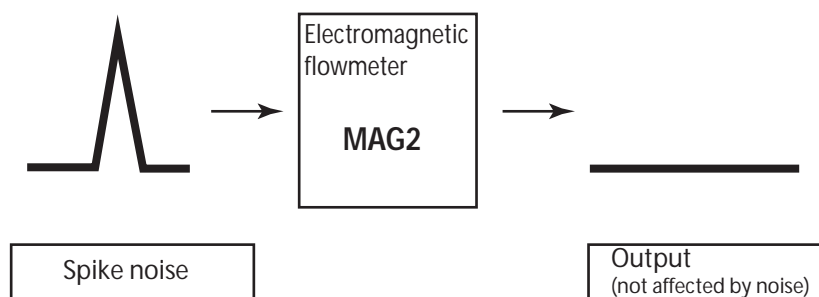

Figure 55. Auto Spike Cut Output Characteristics

Set the auto spike cut in accordance with the following procedure.

CAUTION

You have only ten minutes to return to MEASURING MODE to save the new value before the system resets it to the previously saved value.

Step	Procedure	Screen
1	The screen at right is a screen display example in MEASURING MODE (measurement state). Press the MODE key.	<pre> 20.0 % 01.94 m³/h WPO 00069401 </pre>
2	The OPERATOR'S MODE screen appears for approximately two seconds and then the damping setting screen appears.	<pre> 20.0 % * _ OPERATOR'S MODE </pre> <pre> 20.0 % * _ DAMPING 005.0 s </pre>
3	Press the ↑ key four times to display the screen shown on the right.	<pre> 20.0 % * _ SPIKE CUT OFF </pre>
4	Press the → key to move the cursor to the OFF position.	<pre> 20.0 % * SPIKE CUT OFF </pre>
5	Press the ↑ or ↓ key to select ON or OFF .	<pre> 20.0 % * SPIKE CUT ON </pre>
6	Press the → key to move the cursor to the position under *. Press the MODE key to return to the MEASURING MODE and save data.	<pre> 20.0 % * _ SPIKE CUT OFF </pre>

Setting Moving Average Processing

This function is used to carry out the moving average processing of the measured flow rate values. The model MAG2 performs the flow rate calculation every 400 ms. For example, if the moving average process time is set to 2 seconds, the moving average processing is carried out $2\text{ s}/400\text{ ms} = 5$ times.

If pulsation are generated, this function can be used to suppress the flow rate fluctuations.

The moving average processing can be given by the following formula:

$$Q_{\text{current}} = \frac{\sum_{n=1}^k Q_k}{k}$$

Example) When the moving average processing is set to 2 seconds:

$$Q_{\text{current}} = \frac{q_k + Q_{k-1} + Q_{k-2} + Q_{k-3} + Q_{k-4}}{5}$$

where q_k is a value currently measured, and Q_k is a previous output value.

Set range: ON / OFF

ON (1.0 to 30.0 s)

Default: OFF

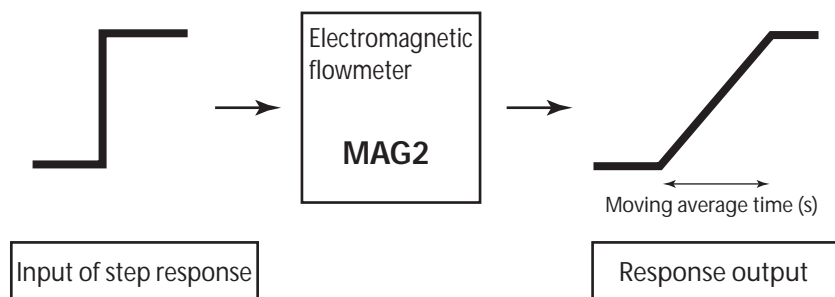

Set the moving average processing in accordance with the following procedure:

⚠ CAUTION
 You have only ten minutes to return to MEASURING MODE to save the new value before the system resets it to the previously saved value.

Step	Procedure	Screen
1	The screen at right is a screen display example in MEASURING MODE (measurement state). Press the MODE key.	<div style="border: 1px solid black; padding: 5px; width: fit-content;"> 20.0 % 01.94 m³/h WP0 00069401 </div>
2	The OPERATOR'S MODE screen appears for approximately two seconds and then the damping setting screen appears.	<div style="border: 1px solid black; padding: 5px; width: fit-content;"> 20.0 % * OPERATOR'S _ MODE </div> <div style="border: 1px solid black; padding: 5px; width: fit-content;"> 20.0 % * DAMPING _ 005.0 s </div>

Step	Procedure	Screen
3	Press the ↑ or ↓ key to display the screen shown on the right.	<div style="border: 1px solid black; padding: 5px; width: fit-content;"> <div style="text-align: right;">20.0 %</div> *_ AVERAGING OFF </div>
4	Press the → key to move the cursor to the OFF position.	<div style="border: 1px solid black; padding: 5px; width: fit-content;"> <div style="text-align: right;">20.0 %</div> *_ AVERAGING <u>OFF</u> </div>
5	Press the ↑ key to switch the OFF screen to the ON screen. Press the → key to move the cursor to the value to be changed.	<div style="border: 1px solid black; padding: 5px; width: fit-content;"> <div style="text-align: right;">20.0 %</div> *_ AVERAGING ON 0<u>1</u>.0 s </div>
6	Press the ↑ or ↓ key to display a value to be set.	<div style="border: 1px solid black; padding: 5px; width: fit-content;"> <div style="text-align: right;">20.0 %</div> *_ AVERAGING ON 0<u>5</u>.0 s </div>
7	Press the → key to move the cursor back to the position under *. Press the MODE key to return to the MEASURING MODE and save data.	<div style="border: 1px solid black; padding: 5px; width: fit-content;"> <div style="text-align: right;">20.0 %</div> *_ AVERAGING ON 05.0 s </div>

Setting Electrode Status Diagnostic Function

Electrode Status Diagnostic function detects the condition of the empty pipe or the scale on the electrodes and sets the analog output and pulse output to the values shown in Table 11.

— CAUTION —

Electrode Status Diagnostic must be set to off if connection is to an asset management system or distributed control system.

The display alternately shows the output values selected and **EMPTY OR SCALE ON ELECTRODE**.

Table 11. Electrode Status Output Mode

Output Display	Parameter Selection in the Electrode Status Output Mode		
	OFF	ZERO	HOLD
Analog 4-20 mA Output	Analog output value representing the measured value.	Analog output is fixed at 0% (4 mA).	Analog Output is held at its last good value.
Pulse Output	Pulse output values representing the measured value.	Pulse output is fixed at zero (does not generate pulses).	Pulse output is held at its present state.

Table 11. Electrode Status Output Mode (Continued)

Output Display	Parameter Selection in the Electrode Status Output Mode		
	OFF	ZERO	HOLD
Display	Displays the measured value.	Flashes the message 0% and Empty or Scale On Electrode alternately (when % flow rate is specified for the main display). Flashes the message 0.000 RATE and Empty or Scale On Electrode alternately (when actual flow rate is specified for the main display). Flashes the message XXXXXXXX (totalized value at setup) and Empty or Scale On Electrode alternately (when totalized value is specified for the main display).	Flashes the last good value and a message of Empty or Scale On Electrode alternately.

Mechanism of Electrode Status Diagnostic Function

Detect an empty pipe condition or a scale on electrode condition by monitoring flow rate signal. Once the flow rate signal fluctuates over a certain threshold, the device judges that the flowtube is empty or scale appears on the electrodes.

There are five threshold levels to meet an environment where the device is installed. Set an appropriate threshold level from below.

SENSITIVITY HIGH

SENSITIVITY MID

SENSITIVITY LOW

SENSITIVITY LL

SENSITIVITY LLL

Outputs

Refer to Table 11.

Operation Conditions

The grounding work must be securely carried out (grounding resistance 100 Ω or less).

The fluid conductivity must be 30 $\mu\text{S}/\text{cm}$ or greater.

The noise level must be higher than or equal to the set threshold value when the pipe is empty.

The noise level must be lower than or equal to the set threshold value when the pipe is filled with fluid.

Default

SENSITIVITY OFF

Setting parameters

Table 12. Set Levels for Electrode Status Diagnostic Function

Electrode Status Diagnostic Sensitivity	Noise Detection Level
SENSITIVITY OFF	Empty pipe detection function OFF
SENSITIVITY HIGH	Signal level Threshold LOW
SENSITIVITY MID	Signal level Threshold MID
SENSITIVITY LOW	Signal level Threshold HIGH
SENSITIVITY LL	Signal level Threshold HIGHER
SENSITIVITY LLL	Signal level Threshold HIGHEST

— NOTE —

1. This function is only available for flowtubes with a bore diameter of 10 mm or more. When the diameter is 2.5 mm or 5 mm, the setting screen for this function appears in the transmitter's display, but is not applicable.
2. This function is applicable for the transmitters with ROM version 7.0 or higher. If it is 6.3 or lower, the setting screen for this function is not displayed. To check the ROM version, refer to “Displaying ROM Version and Date” on page 117. To use the empty pipe detection function with the ROM version 6.3 or lower, the main board must be replaced. For details, contact our sales representative.

Set the Electrode Status Diagnostic function in accordance with the following procedure.

Step	Procedure	Screen
1	The screen at right is a screen display example in MEASURING MODE (measurement state).	<div style="border: 1px solid black; padding: 5px; width: fit-content;"> <p style="text-align: right;">20.0 %</p> <p style="text-align: right;">01.94 m³/h</p> <p>WPO 00069401</p> </div>
2	Press the MODE key. The OPERATOR'S MODE screen appears for approximately two seconds, and then the damping setting screen appears.	<div style="border: 1px solid black; padding: 5px; width: fit-content;"> <p style="text-align: right;">20.0 %</p> <p>* OPERATOR'S _ MODE</p> </div> <div style="border: 1px solid black; padding: 5px; width: fit-content; margin-top: 5px;"> <p style="text-align: right;">20.0 %</p> <p>* DAMPING _ 005.0 s</p> </div>

Step	Procedure	Screen
3	Press the ↑ key to display the screen shown on the right.	<div style="border: 1px solid black; padding: 5px; width: fit-content;"> <p style="text-align: right;">20.0 %</p> <p>* ELECTRODE_ST SENSITIVITY OFF</p> </div>
4	Press the → key to move the cursor to the OFF position.	<div style="border: 1px solid black; padding: 5px; width: fit-content;"> <p style="text-align: right;">20.0 %</p> <p>* ELECTRODE_ST SENSITIVITY OFF_</p> </div>
5	Press the ↑ key to select SENSITIVITY HIGH .	<div style="border: 1px solid black; padding: 5px; width: fit-content;"> <p style="text-align: right;">20.0 %</p> <p>* ELECTRODE_ST SENSITIVITY HIGH</p> </div>
6	Press the → key to move the cursor to the position under *. Press the MODE key to return to the MEASURING MODE, and save the data.	<div style="border: 1px solid black; padding: 5px; width: fit-content;"> <p style="text-align: right;">20.0 %</p> <p>* <u>E</u>LECTRODE_ST SENSITIVITY HIGH</p> </div>
7	<p>Empty the pipe with SENSITIVITY HIGH set to check if the function detects the empty status. Or, in case you find scale on the electrode, set the SENSITIVITY HIGH to check if the function detects the scale on electrode status. Perform the checking when 30 seconds or more have passed, because it takes at least 30 seconds to detect the empty status after the pipe becomes empty or to detect the scale on electrode status.</p> <p>(Result) When the empty or scale on electrode status is detected, the screen at right appears. The EMPTY or SCALE ON ELECTRODE message is flashing, the analog output and the pulse output show the output values as selected in Table 11.</p>	<div style="border: 1px solid black; padding: 5px; width: fit-content;"> <p style="text-align: right;">0.0 %</p> <p>EMPTY OR SCALE ON ELECTRODE</p> </div>

(To the next page)

Step	Procedure	Screen
8	<p>Repeat steps 1 to 5 to set SENSITIVITY MID SENSITIVITY LOW, SENSITIVITY L, or SENSITIVITY LL to check if the function also detects the empty or scale on electrode status with the transmitter's display.</p> <p>Depending on whether the empty or scale on electrode status is detected in each setting, the result falls into one of the following.</p> <p>For results of electrode status diagnostic operation check in empty or scale on electrode status, see Table 13.</p> <ul style="list-style-type: none"> • If the empty or scale on electrode status is not detected when HIGH has been set (in the case of result (6), this function is not available in that installation environment. Repeat steps 1 to 5 to set the function to OFF. 	
9	<p>Next, fill fluid into the pipe. If scale appears on the electrode, clean the electrode first. Check that the empty or scale on electrode status is not detected in this condition. Since it takes at least 30 seconds to clear the empty or scale on electrode status after fluid is filled in the pipe, perform checking when 30 seconds or more have passed after fluid is filled.</p> <p>(Branch 1)</p> <ul style="list-style-type: none"> • When the result is (1) in step 8 Check that the empty or scale on electrode status is not detected when SENSITIVITY LLL has been set. <p>(Result)</p> <ul style="list-style-type: none"> • If the empty status is not detected, use that SENSITIVITY LLL setting without change. • If the empty or scale on electrode status is detected and the screen shown on the right appears, this function is not available in that environment. Set the function to OFF. 	<div style="border: 1px solid black; padding: 5px; text-align: center;"> <p>0.0 % EMPTY OR SCALE ON ELECTRODE</p> </div>

(To the next page)

Step	Procedure	Screen
9 (Continued)	<p>(Branch 2)</p> <ul style="list-style-type: none"> When the result is (2) in Step 8 Check that the empty or scale on electrode status is not detected when SENSITIVITY LL has been set. <p>(Result)</p> <ul style="list-style-type: none"> If the empty or scale on electrode status is not detected, use that SENSITIVITY LL setting without change. If the empty or scale on electrode status is detected and the screen shown on the right appears, this function is not available in that environment. Set the function to OFF. <p>(Branch 3)</p> <ul style="list-style-type: none"> When the result is (3) in Step 8 Check that the empty or scale on electrode status is not detected when SENSITIVITY LOW has been set. <p>(Result)</p> <ul style="list-style-type: none"> If the empty or scale on electrode status is not detected, use that SENSITIVITY LOW setting without change. If the empty or scale on electrode status is detected and the screen shown on the right appears, this function is not available in that environment. Set the function to OFF. <p>(Branch 4)</p> <ul style="list-style-type: none"> When the result is (4) in Step 8 Check that the empty or scale on electrode status is not detected when SENSITIVITY MID has been set. <p>(Result)</p> <ul style="list-style-type: none"> If the empty or scale on electrode status is not detected, use that SENSITIVITY MID setting without change. If the empty or scale on electrode status is detected and the screen shown on the right appears, this function is not available in that environment. Set the function to OFF. 	<div data-bbox="1149 653 1435 758" style="border: 1px solid black; padding: 5px; margin-bottom: 20px;"> <p style="text-align: right;">0.0 %</p> <p>EMPTY OR SCALE ON ELECTRODE</p> </div> <div data-bbox="1149 1184 1435 1289" style="border: 1px solid black; padding: 5px; margin-bottom: 20px;"> <p style="text-align: right;">0.0 %</p> <p>EMPTY OR SCALE ON ELECTRODE</p> </div> <div data-bbox="1149 1751 1435 1856" style="border: 1px solid black; padding: 5px;"> <p style="text-align: right;">0.0 %</p> <p>EMPTY OR SCALE ON ELECTRODE</p> </div>

Step	Procedure	Screen
9 (Continued)	(Branch 5) <ul style="list-style-type: none"> When the result is (5) in Step 8 Check that the empty or scale on electrode status is not detected when SENSITIVITY HIGH has been set. (Result) <ul style="list-style-type: none"> If the empty or scale on electrode status is not detected, use that SENSITIVITY HIGH setting without change. If the empty or scale on electrode status is detected and the screen shown on the right appears, this function is not available in that environment. Set the function to OFF. 	<div style="border: 1px solid black; padding: 5px; text-align: center;"> 0.0 % EMPTY OR SCALE ON ELECTRODE </div>

Table 13. Results of Electrode Status Diagnostic Operation

Setting	Results (1)	Results (2)	Results (3)	Results (4)	Results (5)	Results (6)
LLL	EMPTY or SCALE ON ELECTRODE flashes	EMPTY or SCALE ON ELECTRODE does not flash	EMPTY or SCALE ON ELECTRODE does not flash	EMPTY or SCALE ON ELECTRODE does not flash	EMPTY or SCALE ON ELECTRODE does not flash	EMPTY or SCALE ON ELECTRODE does not flash
LL	EMPTY or SCALE ON ELECTRODE flashes	EMPTY or SCALE ON ELECTRODE flashes	EMPTY or SCALE ON ELECTRODE does not flash	EMPTY or SCALE ON ELECTRODE does not flash	EMPTY or SCALE ON ELECTRODE does not flash	EMPTY or SCALE ON ELECTRODE does not flash
LOW	EMPTY or SCALE ON ELECTRODE flashes	EMPTY or SCALE ON ELECTRODE flashes	EMPTY or SCALE ON ELECTRODE flashes	EMPTY or SCALE ON ELECTRODE does not flash	EMPTY or SCALE ON ELECTRODE does not flash	EMPTY or SCALE ON ELECTRODE does not flash
MID	EMPTY or SCALE ON ELECTRODE flashes	EMPTY or SCALE ON ELECTRODE flashes	EMPTY or SCALE ON ELECTRODE flashes	EMPTY or SCALE ON ELECTRODE flashes	EMPTY or SCALE ON ELECTRODE does not flash	EMPTY or SCALE ON ELECTRODE does not flash
HIGH	EMPTY or SCALE ON ELECTRODE flashes	EMPTY or SCALE ON ELECTRODE flashes	EMPTY or SCALE ON ELECTRODE flashes	EMPTY or SCALE ON ELECTRODE flashes	EMPTY or SCALE ON ELECTRODE flashes	EMPTY or SCALE ON ELECTRODE does not flash

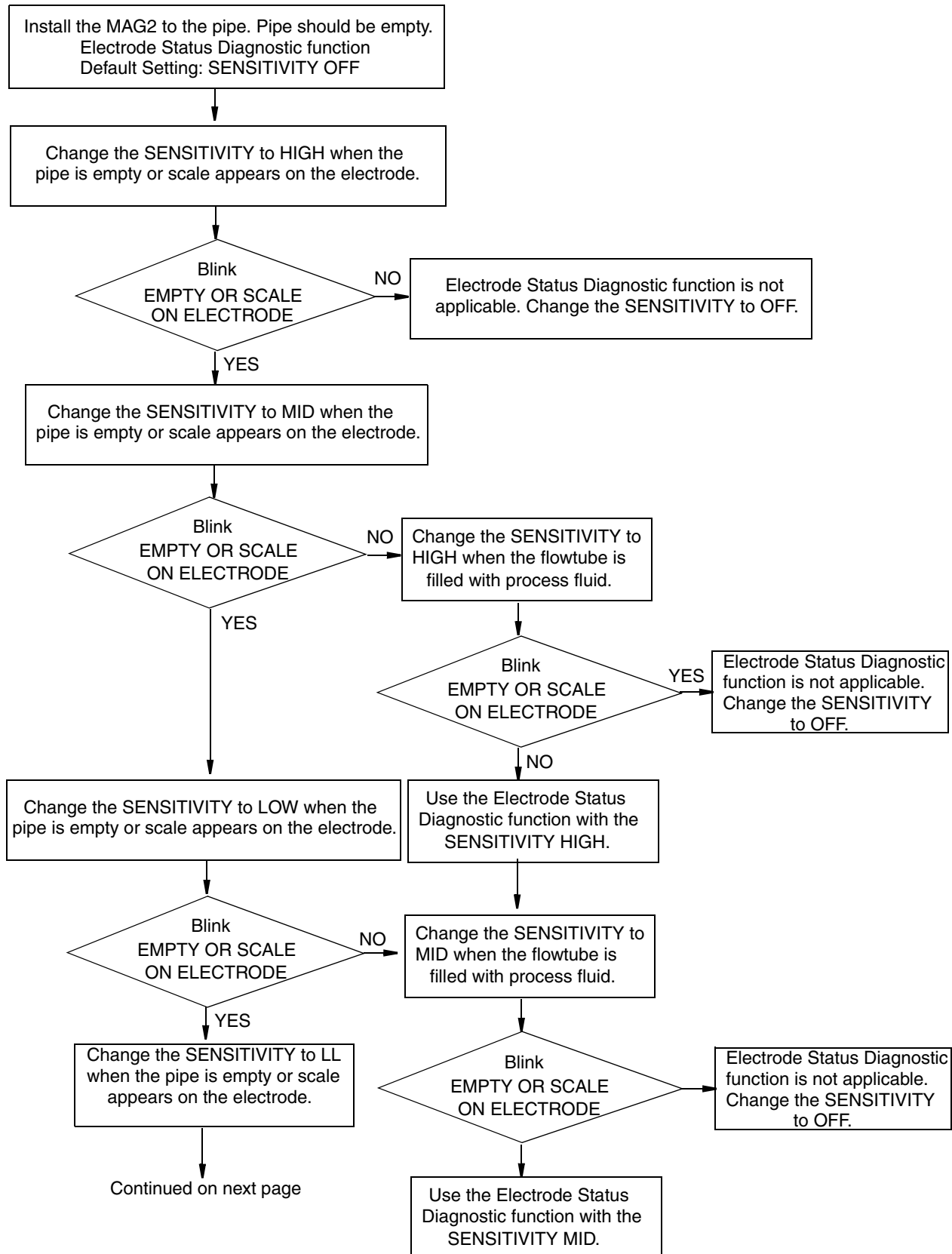

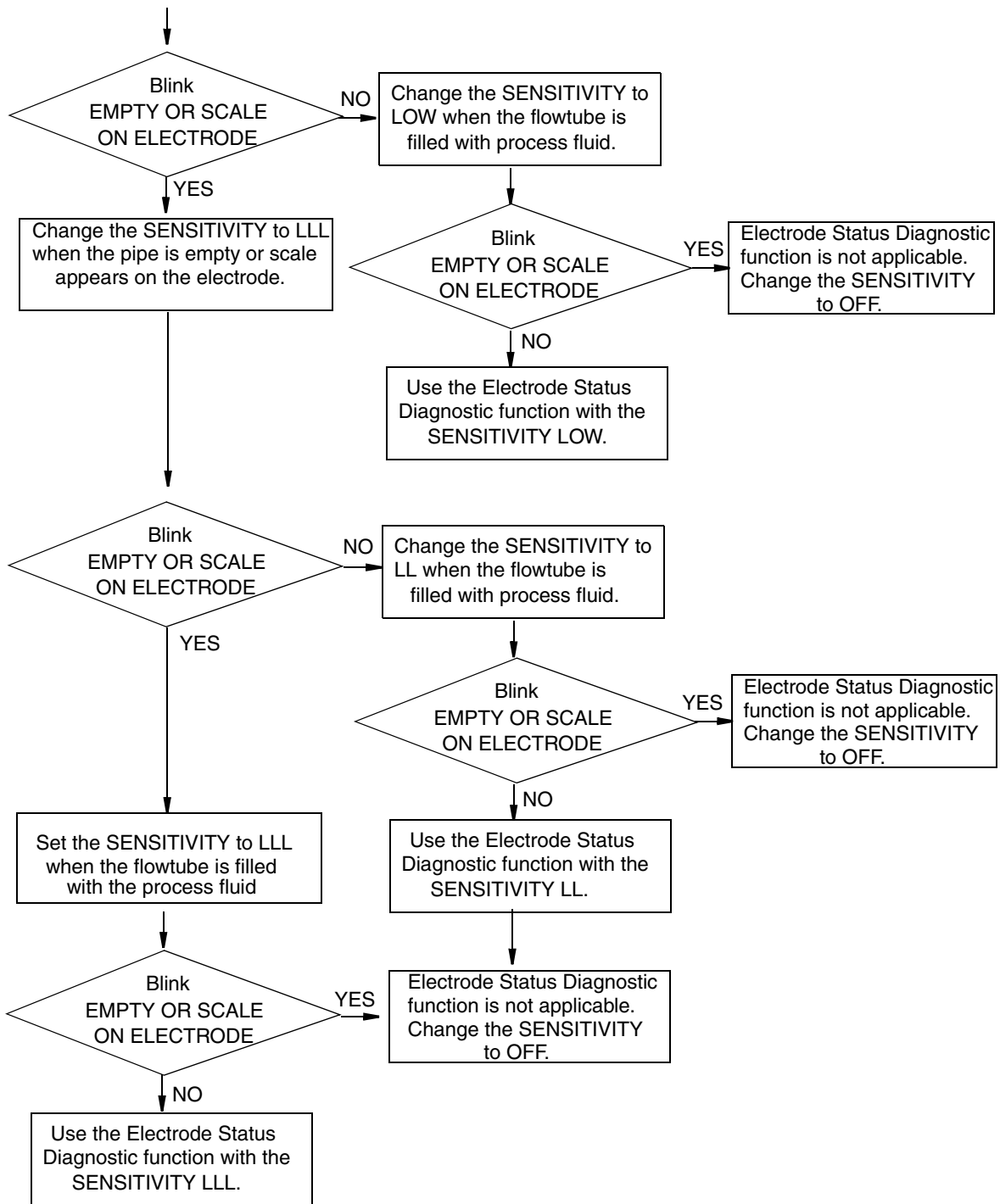

Electrode Status Diagnostic Troubleshooting

If a problem occurs during electrode status diagnostic, take appropriate actions in accordance with the following procedure.

Trouble	Check point and troubleshooting
<ul style="list-style-type: none"> Electrode Status Diagnostic mistake when fluid is filled because the unit is used in the place where the flow rate changes swiftly. 	<p>When the flow rate swiftly changes due to pulsations from the pump, the function may recognize some of the swinging flow rate signals as those in the empty or scale on electrode status and mistakenly determine it as empty or scale on electrode. In this case, it is recommended to install the unit in the place where no effects from the pulsation can be reached, for example, by securing a longer upstream straight pipe section. When the unit is installed in a place where swift change of the flow rate may cause misdetection of the empty or scale on electrode status when fluid is filled, set this function to OFF. Please note that increasing the damping time constant does not solve this problem because this function determines the empty or scale on electrode status based on the signals before the damping process.</p>
<ul style="list-style-type: none"> Empty not detected when the pipe is empty. 	<p>If there is conductivity between electrodes or between the electrode and grounding ring due to the fluid left in the pipe, etc., the empty status may not be detected even when the pipe is empty. In this case, this function is not available. Set it to OFF. If the display and output are not always fixed to zero because, for example, the fluid drops on the electrode, they may become stable at zero by increasing the setting value for low flow cutoff and setting the auto spike cut to ON.</p>
<ul style="list-style-type: none"> Electrode Status Diagnostic operation error after the surrounding noise environment has been changed by expansion of equipment etc., such as changing the installation location or installing the high-current motors or pumps. 	<p>Since change of the environment also changes the noise volume, the electrode status diagnostic may not function correctly with the conventional threshold value for it. In this case, reset the threshold value.</p>

Trouble	Check point and troubleshooting
• Empty detected with flowing fluid in fluid-filled status (empty not detected with stationary fluid).	The empty status may be detected even when the fluid is filled because of the effects of the flow noises generated from the flowing fluid. In this case, reset the threshold value so that the empty status is not mistakenly detected when the fluid is flowing.

Selecting the Electrode Status Output Mode

Setting the output mode when the Electrode Status Diagnostic function detects the empty or scale on electrode status.

20.0 %
*_OPERATOR'S MODE

20.0 %
*_DAMPING 0005.0 s

20.0 %
*_ELECTRODE_ST OUTPUT MODE OFF

20.0 %
*_ELECTRODE_ST OUTPUT MODE OFF

20.0 %
*_ELECTRODE_ST OUTPUT MODE ZERO

20.0 %
*_ELECTRODE_ST OUTPUT MODE HOLD

There are three electrode status output modes: OFF, ZERO, and HOLD. the default setting is OFF. Details of the Electrode Status Output mode are given in Table 11.

Step	Procedure	Screen			
1	The screen at the right is a screen display example in MEASURING MODE (measuring state).	<table border="1"> <tr> <td>20.0 %</td> </tr> <tr> <td>1.94 m³/h</td> </tr> <tr> <td>WP0 00069401</td> </tr> </table>	20.0 %	1.94 m ³ /h	WP0 00069401
20.0 %					
1.94 m ³ /h					
WP0 00069401					

2	Press the MODE key: The OPERATOR'S MODE screen appears for approximately two seconds and then the damping setting screen appears.	<div style="border: 1px solid black; padding: 5px; margin-bottom: 5px;"> * OPERATOR'S 20.0 % _ OPERATOR'S MODE </div> <div style="border: 1px solid black; padding: 5px;"> * DAMPING 20.0 % _ DAMPING 005.0 s </div>
3	Press the \uparrow key to display the screen shown on the right.	<div style="border: 1px solid black; padding: 5px;"> * ELECTRODE_ST 20.0 % OUTPUT MODE OFF </div>
4	Press the \rightarrow key to move the cursor to the OFF position.	<div style="border: 1px solid black; padding: 5px;"> * ELECTRODE_ST 20.0 % OUTPUT MODE <u>OFF</u> </div>
5	Press the \uparrow key to select ELECTRODE_ST OUTPUT MODE. Press the \uparrow or \downarrow key to display the ELECTRODE_ST OUTPUT MODE TO BE SET. Select ZERO, HOLD, or OFF.	<div style="border: 1px solid black; padding: 5px; margin-bottom: 5px;"> * ELECTRODE_ST 20.0 % OUTPUT MODE <u>ZERO</u> </div> <div style="border: 1px solid black; padding: 5px;"> * ELECTRODE_ST 20.0 % OUTPUT MODE <u>HOLD</u> </div>
7	Press the MODE key to return to the MEASURING MODE and to save the data.	

Selecting Flow Rate To Be Displayed In the Main Display

Select the flow rate to be always shown in the main display. The flow rates other than that selected for the main display are shown in the sub displays. Thereby, three flow rates can always be monitored.

Set	Description
%	% flow rate
RATE	Actual flow rate
TOTAL	Totalized value

% (% flow rate): Displays % flow rate

RATE (Actual flow rate)

Setting range:%, RATE, TOTAL

Default:RATE

Select the flow rate to be shown in the main display in accordance with the following procedure:

—  **CAUTION** —

You have only ten minutes to return to MEASURING MODE to save the new value before the system resets it to the previously saved value.

Step	Procedure	Screen
1	The screen at right is a screen display example in MEASURING MODE (measurement state). Press the MODE key.	<div style="border: 1px solid black; padding: 5px; text-align: right;"> 20.0 % 01.94 m³/h WPO 00069401 </div>
2	The OPERATOR'S MODE screen appears for approx. two seconds and then the damping setting screen appears.	<div style="border: 1px solid black; padding: 5px; text-align: right;"> 20.0 % * _ OPERATOR'S MODE </div> <div style="border: 1px solid black; padding: 5px; text-align: right;"> 20.0 % * _ DAMPING 005.0 s </div>
3	Press the ↑ or ↓ key to display the screen as shown on the right.	<div style="border: 1px solid black; padding: 5px; text-align: right;"> 20.0 % * _ DISP SELECT % </div>
4	Press the → key to move the cursor to the position for the flow rate display method (% , RATE , TOTAL). The screen at right shows an example where % flow rate has been set for the main display.	<div style="border: 1px solid black; padding: 5px; text-align: right;"> 20.0 % * _ OPERATOR'S MODE </div>
5	Press the ↑ or ↓ key to select a flow rate display to be set. The screen at right shows an example where RATE (actual flow rate) display has been selected.	<div style="border: 1px solid black; padding: 5px; text-align: right;"> 0.30 RATE * _ DISP SELECT <u>RATE</u> </div>
6	Press the → key to move the cursor to the position under *. Press the MODE key to return to the MEASURING MODE and to change to the set flow rate display.	<div style="border: 1px solid black; padding: 5px; text-align: right;"> 0.30 RATE * _ DISP SELECT RATE </div>

Entering Engineering Mode and Maintenance Mode

This section describes how to enter ENGINEERING MODE, in which setup parameters for the electromagnetic flowmeter are to be configured, and MAINTENANCE MODE, in which calibration and check are to be carried out.

— NOTE —

The mode selection screen may not appear, depending on the settings of write protect. Operate the write protect switch on the main board, and then select one from levels 1, 2 and 3 to display the screen for selecting ENGINEERING MODE only. Select write protect level 0 to display the screen for selecting both ENGINEERING MODE and MAINTENANCE MODE.

The procedure for entering ENGINEERING MODE is shown below.

Step	Procedure	Screen
1	The screen shown right is a screen display example in MEASURING MODE (measurement state). Press the MODE key.	<div style="border: 1px solid black; padding: 5px; width: fit-content;"> 20.0 % 01.94 m³/h WP0 00069401 </div>
2	The OPERATOR'S MODE screen appears for approximately two seconds and then the damping setting screen appears.	<div style="border: 1px solid black; padding: 5px; width: fit-content;"> 20.0 % * _ OPERATOR'S MODE </div> <div style="border: 1px solid black; padding: 5px; width: fit-content; margin-top: 5px;"> 20.0 % * _ DAMPING 005.0 s </div>
3	Press the ↓ key twice to display the screen as shown.	<div style="border: 1px solid black; padding: 5px; width: fit-content;"> 20.0 % * _ MODE ENTER ENGINEERING </div>
4	Press the → key once to move the cursor to the position shown on the screen.	<div style="border: 1px solid black; padding: 5px; width: fit-content;"> 20.0 % * MODE ENTER ENGINEERING </div>
5	Press the ↑ key. With the display is changed, ENGINEERING MODE is active. The screen appears in approximately two seconds.	<div style="border: 1px solid black; padding: 5px; width: fit-content;"> 20.0 % # ENGINEERING MODE </div> <div style="border: 1px solid black; padding: 5px; width: fit-content; margin-top: 5px;"> 20.0 % # ID SET XXXXXXXX </div>

The procedure for entering MAINTENANCE MODE is shown below.

Step	Procedure	Screen
1	The screen shown on the right is a screen display example in MEASURING MODE (measurement state). Press the MODE key.	<div style="border: 1px solid black; padding: 5px; width: fit-content;"> 20.0 % 01.94 m³/h WP0 00069401 </div>

Step	Procedure	Screen
2	The OPERATOR'S MODE screen appears for approximately two seconds and then the damping setting screen appears.	<div style="border: 1px solid black; padding: 5px; width: fit-content;"> <p style="text-align: right;">20.0 %</p> <p>* _ OPERATOR'S MODE</p> </div> <div style="border: 1px solid black; padding: 5px; width: fit-content; margin-top: 5px;"> <p style="text-align: right;">20.0 %</p> <p>* _ DAMPING 005.0 s</p> </div>
3	Press the ↓ key once to display the screen as shown on the right.	<div style="border: 1px solid black; padding: 5px; width: fit-content;"> <p style="text-align: right;">20.0 %</p> <p>* _ MODE ENTER MAINTENANCE</p> </div>
4	Press the → key once to move the cursor to the position shown on the screen.	<div style="border: 1px solid black; padding: 5px; width: fit-content;"> <p style="text-align: right;">20.0 %</p> <p>* MODE ENTER <u>MAINTENANCE</u></p> </div>
5	Press the ↑ key. With the display changed, MAINTENANCE MODE is active. The screen appears in approximately two seconds.	<div style="border: 1px solid black; padding: 5px; width: fit-content;"> <p style="text-align: right;">20.0 %</p> <p>≥ MAINTENANCE MODE</p> </div> <div style="border: 1px solid black; padding: 5px; width: fit-content; margin-top: 5px;"> <p style="text-align: right;">20.0 %</p> <p>≥ OUTPUT CHECK MODE OFF</p> </div>

Configuration of Engineering Mode

The ENGINEERING MODE is comprised of data that is set or changed less frequently than the data in OPERATOR'S MODE. Data can be set and changed at write protect level 0 or 1. At level 2 or 3, only the set data check is allowed.

— CAUTION —

When the mode is changed to MEASURING MODE by pressing the **MODE** key, the set/changed data are saved into a non-volatile memory. Be sure to press the **MODE** key, to save the configured data.

— CAUTION —

Set or changed data are temporarily written into the memory. Note that if the configured data are not saved/written into the memory within 10 minutes, the configured data returns to the previous values. Be sure to press the **MODE** key to return to the MEASURING MODE and to save data.

ENGINEERING MODE has the following setting and adjustment items:

Item	Contents	Screen
ID SET	Sets ID and TAG Number	<div style="border: 1px solid black; padding: 5px; width: fit-content;"> <div style="text-align: right;">20.0 %</div> # ID SET XXXXXXXXXX </div>
FUNC SET	Setting of open collector output, selects pulse output or contact output.	<div style="border: 1px solid black; padding: 5px; width: fit-content;"> <div style="text-align: right;">20.0 %</div> # FUNC SET PULSE </div>
EX, TYPE, DIA	Sets the flowtube information (Ex value, flowtube, and bore diameter).	<div style="border: 1px solid black; padding: 5px; width: fit-content;"> <div style="text-align: right;">20.0 %</div> # EX 300.0 MG2 DIA 200 </div>
C1, C2	Sets the flowtube factor.	<div style="border: 1px solid black; padding: 5px; width: fit-content;"> <div style="text-align: right;">20.0 %</div> # C1 1.0000 C2 1.0234 </div>
SPAN	Sets the flow rate range.	<div style="border: 1px solid black; padding: 5px; width: fit-content;"> <div style="text-align: right;">20.0 %</div> # 1.0000 m/s SPAN 7.0690 m³/h </div>
GRAVITY	Sets the specific gravity when mass flow rate unit is selected.	<div style="border: 1px solid black; padding: 5px; width: fit-content;"> <div style="text-align: right;">20.0 %</div> # GRAVITY 1.0000 </div>

Item	Contents	Screen
COEFFICIENT	Sets a compensation coefficient for flow rate calculation.	<div style="border: 1px solid black; padding: 5px; width: fit-content;"> <div style="text-align: right;">20.0 %</div> # COEFFICIENT <div style="text-align: right;">1.0000</div> </div>
PLS SCL	Sets flow rate (pulse scale) per pulse.	<div style="border: 1px solid black; padding: 5px; width: fit-content;"> <div style="text-align: right;">20.0 %</div> # PLS 10.000 Hz SCL 200.00 I/P </div>
PLS WID	Sets the output pulse width.	<div style="border: 1px solid black; padding: 5px; width: fit-content;"> <div style="text-align: right;">20.0 %</div> # PLS 10.000 Hz WID 0010 ms </div>
DROP OUT	Sets drop out.	<div style="border: 1px solid black; padding: 5px; width: fit-content;"> <div style="text-align: right;">20.0 %</div> # DROPOUT <div style="text-align: right;">10 %</div> </div>
LOW FLOW CUT	Sets low flow cut.	<div style="border: 1px solid black; padding: 5px; width: fit-content;"> <div style="text-align: right;">20.0 %</div> # LOW FLOW CUT <div style="text-align: right;">10 %</div> </div>
HI-ALM/LOW-ALM	Sets upper/lower limit alarm.	<div style="border: 1px solid black; padding: 5px; width: fit-content;"> <div style="text-align: right;">20.0 %</div> # HI-AIM 100 % LO-AIM 0 % </div>
ERROR OUT MODE I. OUT	Determines the analog output failsafe direction.	<div style="border: 1px solid black; padding: 5px; width: fit-content;"> <div style="text-align: right;">20.0 %</div> # ERROR OUT MODE I.OUT HOLD </div>
ERROR OUT MODE P. OUT	Determines the pulse output failsafe direction.	<div style="border: 1px solid black; padding: 5px; width: fit-content;"> <div style="text-align: right;">20.0 %</div> # ERROR OUT MODE P.OUT HOLD </div>
ST. OUT MODE	Sets a contact output status.	<div style="border: 1px solid black; padding: 5px; width: fit-content;"> <div style="text-align: right;">20.0 %</div> # ST. OUTMODE NORMAL CLOSE </div>

— NOTE —

After the **MODE** key is pressed, configured data in the ENGINEERING MODE are saved in non-volatile memory. When configure data, be sure to press the **MODE** key to save the data.

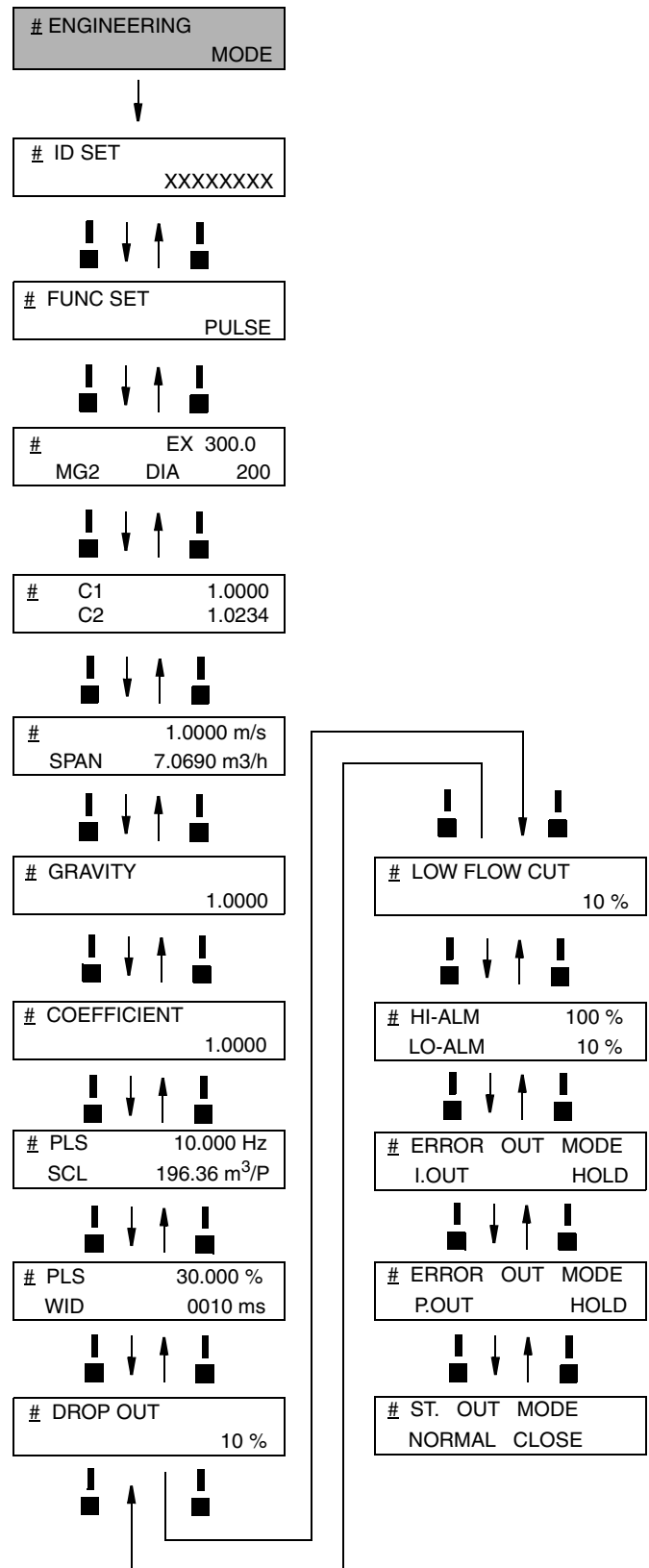

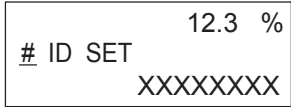

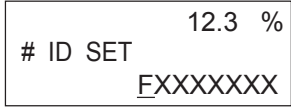

Figure 56. Engineering Mode Menu Tree

Setting ID

You can enter a unique 8-digit alphanumeric code for the flowmeter.

Up to eight alphanumeric characters using any combination of letters (A to Z), numbers (0 to 9), - (dash), / (slash), space and period.

Set an ID in accordance with the following procedure:

Step	Procedure	Screen
1	Enter ENGINEERING MODE (see “Entering Engineering Mode and Maintenance Mode” on page 82) and display the screen where the ID is to be set.	
2	Press the → key to move the cursor to the position under a desired character to be changed.	
3	Press the ↑ or ↓ key to select a desired character.	
4	If a target TAG NO. has been set, press the → key to move the cursor to the position under #. Press the MODE key to return to MEASURING MODE and to save data.	

Selecting Pulse Output, Electrode Status Output, or High Low Status Output

Pulse output, electrode status output, or high low status output are selectable. They are open collector outputs.

When pulse output has been selected:

Set pulse scale, pulse width, drop out, and failsafe mode for the pulse output.

When high low status output has been selected:

As a contact output, self diagnosis output (critical failure) or upper/lower limit alarm is output.

Select % flow rate value for upper/lower alarm or output status (OPEN or CLOSE in normal condition).

When electrode status output has been selected:

As a contact output, empty status or scale on electrode status alarm is output.

Select output status (OPEN or CLOSE in normal condition).

Setting range:

PULSE: Selection of pulse output

HI LO STOUT:

Selection of contact output for upper/lower limit alarm or critical failure status

ELECTRODE STOUT:



Selection of contact output for empty status or scale on electrode status.

Default: PULSE

Select pulse output, electrode status output, or high low status output in accordance with the following procedure.

—  **CAUTION** —

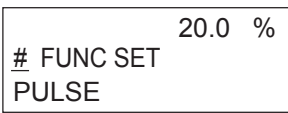
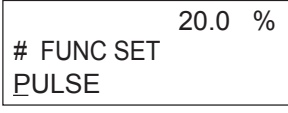
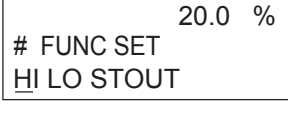
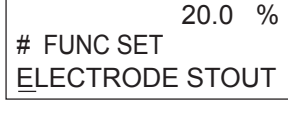
You have only ten minutes to return to MEASURING MODE to save the new value before the system resets it to the previously saved value.

Step	Procedure	Screen
1	Enter ENGINEERING MODE (see “Entering Engineering Mode and Maintenance Mode” on page 82). Then press the ↑ or ↓ key to display the screen at right.	
2	Press the → key to move the cursor to the position for set function. Press the ↑ or ↓ key to display a function to be set. Select PULSE (pulse output), HI LO STOUT (contact output for upper/lower limit alarm or critical failure status), or ELECTRODE STOUT (contact output for empty status or scale on electrode status).	  
3	Press the MODE key to return to the MEASURING MODE and to save data.	

Setting Flowtube Information

Set flowtube information necessary for combination with the transmitter.

EX value: Each flowtube has a unique calibration factor (EX value).

This value is determined at shipment in accordance with the actual flow rate calibration. Do **not** change this value or the flowmeter output will be incorrect.

Flowtube type: When measuring the flow rate, select **MG2** for the flowtube type. To perform adjustments and loop checks, select **TST** for the flowtube type.

Bore diameter: Sets the bore diameter (inside diameter) of the flowtube. The correct bore diameter is set as factory default setting.

Setting range: Flowtube constant: 200.0 to 699.9

Flowtube type: MG2/TST

Bore diameter: 2.5 to 200

Set the flowtube information in accordance with the following procedure:

—  **CAUTION** —

You have only ten minutes to return to MEASURING MODE to save the new value before the system resets it to the previously saved value.

Step	Procedure	Screen									
1	Enter ENGINEERING MODE (see “Entering Engineering Mode and Maintenance Mode” on page 82). Then press the ↑ or ↓ key to display the screen at right.	<table border="1"> <tr> <td></td> <td></td> <td>12.3 %</td> </tr> <tr> <td>#</td> <td>EX</td> <td>300.0</td> </tr> <tr> <td>MG2</td> <td>DIA</td> <td>050.0</td> </tr> </table>			12.3 %	#	EX	300.0	MG2	DIA	050.0
		12.3 %									
#	EX	300.0									
MG2	DIA	050.0									
2	Press the → key to set the flowtube constant. Using the ↑ or ↓ key, enter the numeric value found in the EX column stamped on the nameplate of the flowtube to be combined.	<table border="1"> <tr> <td></td> <td></td> <td>12.3 %</td> </tr> <tr> <td>#</td> <td>EX</td> <td>3<u>20</u>.0</td> </tr> <tr> <td>MG2</td> <td>DIA</td> <td>050.0</td> </tr> </table>			12.3 %	#	EX	3 <u>20</u> .0	MG2	DIA	050.0
		12.3 %									
#	EX	3 <u>20</u> .0									
MG2	DIA	050.0									
3	In addition, press the → key to select the flowtube type. Using the ↑ or ↓ key, select the flowtube type. To measure the flow rate, select MG2 . To perform adjustments and loop checks, select TST .	<table border="1"> <tr> <td></td> <td></td> <td>12.3 %</td> </tr> <tr> <td>#</td> <td>EX</td> <td>320.0</td> </tr> <tr> <td><u>MG2</u></td> <td>DIA</td> <td>050.0</td> </tr> </table>			12.3 %	#	EX	320.0	<u>MG2</u>	DIA	050.0
		12.3 %									
#	EX	320.0									
<u>MG2</u>	DIA	050.0									
4	Then press the → key to select the bore diameter. Using the ↑ or ↓ key, select the bore diameter of the flowtube.	<table border="1"> <tr> <td></td> <td></td> <td>12.3 %</td> </tr> <tr> <td>#</td> <td>EX</td> <td>320.0</td> </tr> <tr> <td>MG2</td> <td>DIA</td> <td>100.<u>0</u></td> </tr> </table>			12.3 %	#	EX	320.0	MG2	DIA	100. <u>0</u>
		12.3 %									
#	EX	320.0									
MG2	DIA	100. <u>0</u>									
5	Using the → key, move the cursor to the position under #. Press the MODE key to return to the MEASURING MODE and save data.	<table border="1"> <tr> <td></td> <td></td> <td>12.3 %</td> </tr> <tr> <td><u>#</u></td> <td>EX</td> <td>320.0</td> </tr> <tr> <td>MG2</td> <td>DIA</td> <td>100.0</td> </tr> </table>			12.3 %	<u>#</u>	EX	320.0	MG2	DIA	100.0
		12.3 %									
<u>#</u>	EX	320.0									
MG2	DIA	100.0									

Setting the Flowtube Factor

Set the flowtube factor. The C1 value is always 1.0000. Set the C2 value to that shown on the flowtube nameplate under the heading **Detector Factor**.

Step	Procedure	Screen									
1	Enter ENGINEERING MODE (see “Entering Engineering Mode and Maintenance Mode” on page 82). Then press the ↑ or ↓ key to display the screen at right.	<table border="1"> <tr> <td></td> <td></td> <td>12.3 %</td> </tr> <tr> <td>#</td> <td>C1</td> <td>1.0000</td> </tr> <tr> <td></td> <td>C2</td> <td>1.0234</td> </tr> </table>			12.3 %	#	C1	1.0000		C2	1.0234
		12.3 %									
#	C1	1.0000									
	C2	1.0234									
2	Press the → key to set the flowtube factor. C1 is always set to 1.0000. Set the C2 factor to that stamped on the nameplate of the flowmeter.	<table border="1"> <tr> <td></td> <td></td> <td>12.3 %</td> </tr> <tr> <td>#</td> <td>C1</td> <td>1.0000</td> </tr> <tr> <td></td> <td>C2</td> <td>1.0234</td> </tr> </table>			12.3 %	#	C1	1.0000		C2	1.0234
		12.3 %									
#	C1	1.0000									
	C2	1.0234									
3	Press the → key to move the cursor to the position under #. Press MODE key to return to the MEASURING MODE, and to save data.	<table border="1"> <tr> <td></td> <td></td> <td>12.3 %</td> </tr> <tr> <td>#</td> <td>C1</td> <td>1.0000</td> </tr> <tr> <td></td> <td>C2</td> <td>1.0234</td> </tr> </table>			12.3 %	#	C1	1.0000		C2	1.0234
		12.3 %									
#	C1	1.0000									
	C2	1.0234									

Setting Flow Rate Range

Set the flow rate range. The lower limit of the range is ZERO. The upper limit, which is the value when the output reaches 100%, is entered here along with the selection of engineering and time units. The range has an upper limit value of 10 m/s in flow velocity when it is calculated at the upper stage of the display. It has a lower limit value of 0.3 m/s.

Set the flow rate range so that the regular flow rate to greater than or equal to 50% of the flow rate range.

Pressing the **MODE** key automatically deletes unnecessary zeros, if any, from the flow rate range.

Example: 07.069 → 7.0690 (Unnecessary zero is deleted.)

Setting range:

Flow rate range: 0 to 0.0001, 0 to 99999.

Units of flow rate:

Unit of SI volume flow rate: m³, l, cm³

Unit of SI mass flow rate: t, kg, g

Unit of non-SI volume flow rate: G (gallon), mG, kG, B (barrel),
IG (imperial gallon), mIG, kIG

Unit of SI mass flow rate: lb

Unit of time: d, h, min., s

Default: 10.000 m³/h

— NOTE —

Select the same unit systems (volume unit or mass unit) for the flow rate range and pulse scale. Selection of different unit systems for them causes set errors (Err-22 PULSE WEIGHT SETTING ERROR). (See “Error Code Of Set Errors” on page 120.)

Set the flow rate range in accordance with the following procedure.

! CAUTION

You have only ten minutes to return to MEASURING MODE to save the new value before the system resets it to the previously saved value.

Step	Procedure	Screen
1	Enter ENGINEERING MODE (see “Entering Engineering Mode and Maintenance Mode” on page 82). Then press the ↑ or ↓ key to display the screen at right.	<div style="border: 1px solid black; padding: 5px; width: fit-content;"> 12.3 % # 1.4147 m/s SPAN 10.000 m³/h </div>
2	Press the → key to move the cursor to a desired digit to be set.	<div style="border: 1px solid black; padding: 5px; width: fit-content;"> 12.3 % # 1.4147 m/s SPAN <u>1</u>0.000 m³/h </div>
3	Using the ↑ or ↓ key, change the value to a desired one.	<div style="border: 1px solid black; padding: 5px; width: fit-content;"> 12.3 % # 1.4147 m/s SPAN 20.000 m³/h </div>
4	In addition, press the → key to move the cursor to the position under a desired flow rate unit. Using the ↑ or ↓ key, select the unit.	<div style="border: 1px solid black; padding: 5px; width: fit-content;"> 12.3 % # 1.4147 m/s SPAN 20.000 <u>l</u>/h </div>
5	Then press the → key to move the cursor to the position under the time unit. Using the ↑ or ↓ key, select the unit.	<div style="border: 1px solid black; padding: 5px; width: fit-content;"> 12.3 % # 1.4147 m/s SPAN 333.33l/ <u>min</u> </div>
6	Press the → key to move the cursor to the position under #. Press MODE key to return to the MEASURING MODE, and to save data.	<div style="border: 1px solid black; padding: 5px; width: fit-content;"> 12.3 % # 1.4147 m/s SPAN 333.33l/ min </div>

Setting and Changing Compensation Coefficient

This function is used to set or change the compensation coefficient which is used to multiply the output flow rate as required.

Set range: 0.10000 to 5.9999

Default: 1.0000

Set and change a compensation coefficient in accordance with the following procedure.

! CAUTION

You have only ten minutes to return to MEASURING MODE to save the new value before the system resets it to the previously saved value.

Step	Procedure	Screen
1	Enter ENGINEERING MODE (see “Entering Engineering Mode and Maintenance Mode” on page 82). Then press the ↑ or ↓ key to display the screen at right.	<div style="border: 1px solid black; padding: 5px; width: fit-content;"> <div style="text-align: right;">12.3 %</div> # COEFFICIENT <div style="text-align: right;">1.0000</div> </div>
2	Press the → key to move the cursor to the position under a desired value to be set or changed.	<div style="border: 1px solid black; padding: 5px; width: fit-content;"> <div style="text-align: right;">12.3 %</div> # COEFFICIENT <div style="text-align: right;">1.00<u>0</u>0</div> </div>
3	Using the ↑ or ↓ key, change the value to the desired one to be set.	<div style="border: 1px solid black; padding: 5px; width: fit-content;"> <div style="text-align: right;">12.3 %</div> # COEFFICIENT <div style="text-align: right;">1.00<u>5</u>0</div> </div>
4	Press the → key to move the cursor to the position under #. Press the MODE key to return to the MEASURING MODE and to save data.	<div style="border: 1px solid black; padding: 5px; width: fit-content;"> <div style="text-align: right;">12.3 %</div> # COEFFICIENT <div style="text-align: right;">1.0050</div> </div>

Setting Specific Gravity

This function is used to set the specific gravity when selecting a weight unit (t, kg, g, lb) in the flow rate range setting.

Set range:0.1000 to 5.9999

Default:1.0000

Set the specific gravity in accordance with the following procedure.

— CAUTION

You have only ten minutes to return to MEASURING MODE to save the new value before the system resets it to the previously saved value.

Step	Procedure	Screen
1	Enter ENGINEERING MODE (see “Entering Engineering Mode and Maintenance Mode” on page 82). Then press the ↑ or ↓ key to display the screen at right.	<div style="border: 1px solid black; padding: 5px; width: fit-content;"> <div style="text-align: right;">12.3 %</div> # GRAVITY <div style="text-align: right;">1.0000</div> </div>
2	Press the → key to move the cursor to the position under a desired value to be set or changed.	<div style="border: 1px solid black; padding: 5px; width: fit-content;"> <div style="text-align: right;">12.3 %</div> # GRAVITY <div style="text-align: right;">1.00<u>0</u>0</div> </div>

Step	Procedure	Screen
3	Using the ↑ or ↓ key, change the value to the desired one to be set.	<div style="border: 1px solid black; padding: 5px; width: fit-content;"> 12.3 % # GRAVITY 1.0050 </div>
4	Press the → key to move the cursor to the position under #. Press the MODE key to return to the MEASURING MODE and to save data.	<div style="border: 1px solid black; padding: 5px; width: fit-content;"> 12.3 % # GRAVITY 1.0050 </div>

Setting Pulse Scale

This function is used to set the flow rate per pulse and associated units for a flowmeter. Pulse scale of the totalization value indicated on the display is equal to the pulse scale set here.

Set range: 0.0001 to 99999.

However, the pulse scale should be set so that the pulse output span frequency f_s (shown in the auxiliary display) is between 0.0001 Hz and 200 Hz.

$$0.0001 \text{ Hz} \leq f_s \leq 200 \text{ Hz}$$

Units of flow rate:

Unit of SI volume flow rate: m^3 , l, cm^3

Unit of SI mass flow rate: t, kg, g

Unit of non-SI volume flow rate: mG, G, kG, B, mIG, IG, kIG

Unit of SI mass flow rate: lb

Unit of time: d, h, min., s

Default: 10.000 m^3/P

— NOTE —

Select the same unit systems (volume unit or mass unit) for the flow rate range and pulse scale. Selection of different unit systems for them causes set errors (Err-22 PULSE WEIGHT SETTING ERROR). (See “Error Code Of Set Errors” on page 120.)

Calculation method of span frequency:

Span frequency f_s can be calculated by the following formula:

$$f_s = (\text{Flow rate range}) / (\text{Pulse scale})$$

To calculate f_s , pay attention to the following points:

- ◆ Convert flow range into units per second.
- ◆ Select the same unit of flow rate for flow rate range and pulse scale.

Example: When flow rate range: 60 l/min., and pulse scale: 10 cm^3/P

1. Convert the flow rate range into the flow rate range per second.

60 l/min. → 60/60 l/s

= 1 l/s

2. Select the same unit of flow rate for flow rate range and pulse scale.
In this example, the unit of pulse scale is changed.

$10 \text{ cm}^3/\text{P} \rightarrow 10/1000 \text{ l/P}$

= 0.01 l/P

3. Calculate the span frequency.

$(1 \text{ l/P}) / (0.01 \text{ l/P})$

= 100 Hz

$f_s = 100 \text{ Hz}$

Set pulse scale in accordance with the following procedure.

—! CAUTION —

You have only ten minutes to return to MEASURING MODE to save the new value before the system resets it to the previously saved value.

Step	Procedure	Screen
1	Enter ENGINEERING MODE (see “Entering Engineering Mode and Maintenance Mode” on page 82). Then press the ↑ or ↓ key to display the screen at right.	<div style="border: 1px solid black; padding: 5px; width: fit-content;"> <div style="text-align: right; margin-bottom: 5px;">12.3 %</div> # PLS 27.780 Hz SCL 100.00 l/p </div>
2	Press the → key to move the cursor to the position under a desired value to be set or changed.	<div style="border: 1px solid black; padding: 5px; width: fit-content;"> <div style="text-align: right; margin-bottom: 5px;">12.3 %</div> # PLS 27.780 Hz SCL <u>100.00</u> l/p </div>
3	Using the ↑ or ↓ key, change the value to a desired pulse scale to be set.	<div style="border: 1px solid black; padding: 5px; width: fit-content;"> <div style="text-align: right; margin-bottom: 5px;">12.3 %</div> # PLS 13.890 Hz SCL <u>200.00</u> l/p </div>
4	Press the → key to move the cursor to the position under #. Press the MODE key to return to the MEASURING MODE and to save data.	<div style="border: 1px solid black; padding: 5px; width: fit-content;"> <div style="text-align: right; margin-bottom: 5px;">12.3 %</div> # PLS 13.890 Hz SCL 200.00 l/p </div>

Setting Pulse Width

Set a pulse width. The pulse width should be set in accordance with the specifications of the pulse receiver installed.

Set range

DUTY 50%

Pulse width that is DUTY 50% of the span frequency, and 1,000 ms (1s) maximum.
The pulse duty ratio defines the pulse ON time versus the pulse OFF time as a percentage of the total pulse cycle.

NUM (setting of a real value)

0001 to 1,000 ms (1 s)

* With DUTY 50%, no setting error appears.

*With NUM (with a real value set), a setting error occurs if the pulse width exceeds the DUTY ratio of 70% in span frequency.

Default: DUTY 50%

Method of setting pulse width:

The DUTY ratio is B/A (%) in the diagram at right.

1. NUM (when real pulse width is selected)

DUTY ratio < 70%

Set the pulse width as shown below.

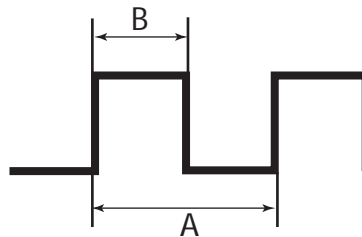

Calculation method: When the range is 360 m³, and pulse scale is 2 l/P,

First convert the unit of range to calculate the span frequency.

Convert the range into the unit of per-second (/s).

$$360 \text{ m}^3/\text{s} \rightarrow 0.1 \text{ m}^3/\text{s}$$

Convert the unit of flow rate range to be same as the unit of pulse scale.

$$0.1 \text{ m}^3/\text{s} \rightarrow 0.1 \times 1000 \text{ l/s}$$

$$= 100 \text{ l/s}$$

Calculation of span frequency

$$(100 \text{ l/s}) / (2 \text{ l/P})$$

$$= 50 \text{ Hz}$$

$$50 \text{ Hz} \rightarrow 20 \text{ ms} (= A)$$

Calculation of pulse width where the DUTY ratio is equivalent to 70%

$$B = 0.7 \times A$$

$$= 0.7 \times 20 \text{ ms}$$

$$= 14 \text{ ms}$$

Therefore, set the pulse width to less than 14 ms.

2. DUTY 50% (Automatically set)

Selecting DUTY 50% automatically sets the pulse width as follows:

Calculation method 1

Make calculations to obtain a pulse width that is DUTY 50% of the span frequency. The pulse width is automatically set. In this case, the calculated value of the pulse width does not appear on the display.

Calculation method 2

In addition, if the pulse width calculated by the calculation method 1 exceeds 1 second, the pulse width is set to 1 second.

Calculation method 1: When the range is 360 m³/h, and pulse scale is 2 l/P,

First convert the unit of range to calculate the span frequency.

Convert the range into the unit of per-second (/s).

$$360 \text{ m}^3/\text{h} \rightarrow 0.1 \text{ m}^3/\text{s}$$

Convert the unit of flow rate range to be same as the unit of pulse scale.

$$0.1 \text{ m}^3/\text{s} \rightarrow 0.1 \times 1000 \text{ l/s}$$

$$100 \text{ l/s}$$

Calculation of span frequency

$$(100 \text{ l/s}) / (2 \text{ l/P})$$

$$= 50 \text{ Hz}$$

$$50 \text{ Hz} \rightarrow 20 \text{ ms} (= A)$$

Calculation of pulse width where the DUTY ratio is equivalent to 50%

$$B = 0.5 \times A$$

$$= 0.5 \times 20 \text{ ms}$$

$$= 10 \text{ ms}$$

Therefore, the pulse width is 10 ms.

Calculation method 2: When the range is 36 m³/h, and pulse scale is 100 l/P,

First convert the unit of range to calculate the span frequency.

Convert the range into the unit of per-second (/s).

$$36 \text{ m}^3/\text{h} \rightarrow 0.01 \text{ m}^3/\text{s}$$

Convert the unit of flow rate range to be same as unit of pulse scale.

$$0.01 \text{ m}^3/\text{s} \rightarrow 0.01 \times 1000 \text{ l/s}$$

$$10 \text{ l/s}$$

Calculation of span frequency

$$(10 \text{ l/s}) / (100 \text{ l/p})$$

$$= 0.1 \text{ Hz}$$

$$0.1 \text{ Hz} \rightarrow 10 \text{ s} (= A)$$

Calculation of pulse width where the DUTY ratio is equivalent to 50%

$$B = 0.5 \times A$$

$$= 0.5 \times 10 \text{ s}$$

$$= 5 \text{ s}$$

Because the calculated pulse width exceeds 1 s, it takes 1s.

Set a pulse width in accordance with the following procedure.

⚠ CAUTION

You have only ten minutes to return to MEASURING MODE to save the new value before the system resets it to the previously saved value.

Step	Procedure	Screen
1	Enter ENGINEERING MODE (see “Entering Engineering Mode and Maintenance Mode” on page 82). Then press the ↑ or ↓ key to display the screen at right.	<div style="border: 1px solid black; padding: 5px; width: fit-content;"> <div style="text-align: right; margin-bottom: 5px;">12.3 %</div> # PLS 27.778 % WID NUM 010.00ms </div>
2	Press the → key to move the cursor to the position under NUM .	<div style="border: 1px solid black; padding: 5px; width: fit-content;"> <div style="text-align: right; margin-bottom: 5px;">12.3 %</div> # PLS 27.778 % WID <u>N</u>UM 010.00ms </div>
3	Pressing the ↑ key switches a screen for entering a numeric value for pulse width to a screen for fixing the DUTY ratio to 50%.	<div style="border: 1px solid black; padding: 5px; width: fit-content;"> <div style="text-align: right; margin-bottom: 5px;">12.3 %</div> # PLS WID <u>D</u>UTY 50 % </div>
4	To enter a numeric value for pulse width, press the ↑ key to return to the screen for the entry of numeric values. Using the → key, move the cursor to the position under a desired digit to be set.	<div style="border: 1px solid black; padding: 5px; width: fit-content;"> <div style="text-align: right; margin-bottom: 5px;">12.3 %</div> # PLS 27.778 % WID NUM 01<u>0</u>.00ms </div>
5	Using the ↑ or ↓ key, change the value to a desired value to be set.	<div style="border: 1px solid black; padding: 5px; width: fit-content;"> <div style="text-align: right; margin-bottom: 5px;">12.3 %</div> # PLS 13.889 % WID NUM 00<u>5</u>.00ms </div>
6	Press the → key to move the cursor to the position under #. Press the MODE key to return to the MEASURING MODE and to save data.	<div style="border: 1px solid black; padding: 5px; width: fit-content;"> <div style="text-align: right; margin-bottom: 5px;">12.3 %</div> # PLS 13.889 % WID NUM 005.00ms </div>

Setting Drop Out

This function is used to set the drop out value for the pulse output. The pulse output is cut off at this point to avoid flow pulsation in range values close to zero, thus preventing incorrect totalization of the flow rate.

Pulse counting pauses when the flow rate reaches this preset percentage of the set range.





Setting range: 0 to 10%

Default: 2%

Set drop out in accordance with the following procedure.

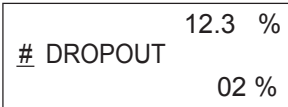
— CAUTION —

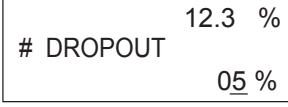
You have only ten minutes to return to MEASURING MODE to save the new value before the system resets it to the previously saved value.

Step	Procedure	Screen
1	Enter ENGINEERING MODE (see “Entering Engineering Mode and Maintenance Mode” on page 82). Then press the ↑ or ↓ key to display the screen at right.	
2	Press the → key.	
3	Using the ↑ or ↓ key, change the value to a desired value to be set.	
4	Press the → key to move the cursor to the position under #. Press the MODE key to return to the MEASUREMENT MODE and to save data.	

Setting Low Flow Cutoff

This function is used to set the low flow cutoff value. When the flow rate reaches the entered value, the analog output is cut off and latched to 4 mA (display flow rate of 0%) to avoid errors due to flow pulsation in range value close to zero.

Also, for reverse flow rate the output is latched to 4 mA (display flow rate of 0%)

The lower limit of the low flow cutoff setting is determined by the velocity range.

1. If the velocity range exceeds 3 m/s, the lower limit value is 1%.
2. If the flow velocity range is 3 m/s or less, the lower limit value is the value that cut the flow velocity of 0.03 m/s or less flow rate.

Example: If the flow velocity range is set as 2 m/s, the lower limit of the low flow cutoff value is 1.5%. ($= 0.03/2 = 0.015 = 1.5\%$)

Setting Range: 1 to 10%

Default: Depends on the velocity range.

Set low flow cut in accordance with the following procedure.

—  **CAUTION** —

You have only ten minutes to return to MEASURING MODE to save the new value before the system resets it to the previously saved value.

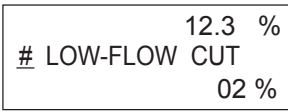
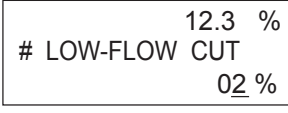
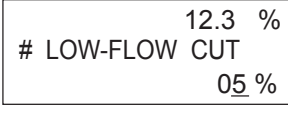
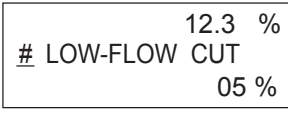
Step	Procedure	Screen
1	Enter ENGINEERING MODE (see “Entering Engineering Mode and Maintenance Mode” on page 82). Then press the ↑ or ↓ key to display the screen at right.	
2	Press the → key. The cursor then moves to the position of the low flow cut value.	
3	Using the ↑ or ↓ key, change the value to a desired value to be set.	
4	Press the → key to move the cursor to the position under #. Press the MODE key to return to MEASURING MODE and to save data.	

Setting Upper and Lower Limit Alarm

This function is used to set the upper and lower limit alarm set points when the contact output is selected.

An alarm is output when the flow rate exceeds these preset upper and lower limits.

The alarm output status depends on the “Setting contact output status” described later.

Set range: HI-ALM0% to +115%

LO-ALM0% to +115%

Default: HI-ALM+115%

LO-ALM0%

Set the upper/lower limit alarm in accordance with the following procedure.

! CAUTION

You have only ten minutes to return to MEASURING MODE to save the new value before the system resets it to the previously saved value.

Step	Procedure	Screen						
1	Enter ENGINEERING MODE (see “Entering Engineering Mode and Maintenance Mode” on page 82). Then press the ↑ or ↓ key to display the screen at right.	<table border="1"> <tr> <td></td> <td>12.3 %</td> </tr> <tr> <td># HI-ALM</td> <td>+115%</td> </tr> <tr> <td>LO-ALM</td> <td>+000%</td> </tr> </table>		12.3 %	# HI-ALM	+115%	LO-ALM	+000%
	12.3 %							
# HI-ALM	+115%							
LO-ALM	+000%							
2	Using the → key, move the cursor to the position under a digit to be set or changed.	<table border="1"> <tr> <td></td> <td>12.3 %</td> </tr> <tr> <td># HI-ALM</td> <td>+1<u>0</u>0%</td> </tr> <tr> <td>LO-ALM</td> <td>-000%</td> </tr> </table>		12.3 %	# HI-ALM	+1 <u>0</u> 0%	LO-ALM	-000%
	12.3 %							
# HI-ALM	+1 <u>0</u> 0%							
LO-ALM	-000%							
3	Using the ↑ or ↓ key, change the value to the desired value to be set.	<table border="1"> <tr> <td></td> <td>12.3 %</td> </tr> <tr> <td># HI-ALM</td> <td>+0<u>8</u>0%</td> </tr> <tr> <td>LO-ALM</td> <td>-000%</td> </tr> </table>		12.3 %	# HI-ALM	+0 <u>8</u> 0%	LO-ALM	-000%
	12.3 %							
# HI-ALM	+0 <u>8</u> 0%							
LO-ALM	-000%							
4	Press the → key to move the cursor to the position under #. Press MODE key to return to the MEASURING MODE and to save data.	<table border="1"> <tr> <td></td> <td>12.3 %</td> </tr> <tr> <td># HI-ALM</td> <td>+080%</td> </tr> <tr> <td>LO-ALM</td> <td>-000%</td> </tr> </table>		12.3 %	# HI-ALM	+080%	LO-ALM	-000%
	12.3 %							
# HI-ALM	+080%							
LO-ALM	-000%							

However, set as follows: HI-ALM > LO-ALM.

Selecting Failsafe Mode For Analog Outputs

This function is used to determine the analog output direction when the flowmeter detects a critical status condition.

! CAUTION

The failsafe mode is very important for the overall safety of the control process. Choose the failsafe direction carefully, as equipment damage can result from a wrong choice.

Setting range:LOW Analog output is driven to low scale (TYP 3.7 mA)

HIGH Analog output is driven to high scale (TYP 21.8 mA)

HOLD Analog output is held at its last good value.

Default: LOW

Set failsafe mode for analog output in accordance with the following procedure.

! CAUTION

You have only ten minutes to return to MEASURING MODE to save the new value before the system resets it to the previously saved value.

Step	Procedure	Screen
1	Enter ENGINEERING MODE (see “Entering Engineering Mode and Maintenance Mode” on page 82). Then press the ↑ or ↓ key to display the screen at right.	<div style="border: 1px solid black; padding: 5px; width: fit-content;"> <div style="text-align: right;">12.3 %</div> # ERROR OUT MODE I.OUT LOW </div>
2	Press the → key.	<div style="border: 1px solid black; padding: 5px; width: fit-content;"> <div style="text-align: right;">12.3 %</div> # ERROR OUT MODE I.OUT <u>L</u>OW </div>
3	Using the ↑ or ↓ key, determine the failsafe mode for analog output.	<div style="border: 1px solid black; padding: 5px; width: fit-content;"> <div style="text-align: right;">12.3 %</div> # ERROR OUT MODE I.OUT <u>H</u>IGH </div>
4	Press the → key to move the cursor to the position under #. Press the MODE key to return to the MEASURING MODE and to save data.	<div style="border: 1px solid black; padding: 5px; width: fit-content;"> <div style="text-align: right;">12.3 %</div> # ERROR OUT MODE I.OUT HIGH </div>

Selecting Failsafe Mode for Pulse Output

This function is used to determine the pulse output direction when the flowmeter detects a critical status condition.

— CAUTION —

The failsafe mode is very important for the overall safety of the control process. Choose the failsafe direction carefully, as equipment damage can result from a wrong choice.

Set range: OFF Outputs no pulse.

HOLD Pulse output signal held at its present state

Default: OFF

Set failsafe mode for pulse output in accordance with the following procedure.

— CAUTION —

You have only ten minutes to return to MEASURING MODE to save the new value before the system resets it to the previously saved value.

Step	Procedure	Screen
1	Enter ENGINEERING MODE (see “Entering Engineering Mode and Maintenance Mode” on page 82). Then press the ↑ or ↓ key to display the screen at right.	<div style="border: 1px solid black; padding: 5px; width: fit-content;"> <div style="text-align: right;">12.3 %</div> # ERROR OUT MODE P.OUT OFF </div>

Step	Procedure	Screen
2	Press the → key.	<div style="border: 1px solid black; padding: 5px; width: fit-content;"> <div style="text-align: right;">12.3 %</div> # ERROR OUT MODE P.OUT <u>OFF</u> </div>
3	Using the ↑ or ↓ key, determine the failsafe mode for pulse output.	<div style="border: 1px solid black; padding: 5px; width: fit-content;"> <div style="text-align: right;">12.3 %</div> # ERROR OUT MODE P.OUT <u>HOLD</u> </div>
4	Press the → key to move the cursor to the position under #. Press the MODE key to return to the MEASURING MODE and to save data.	<div style="border: 1px solid black; padding: 5px; width: fit-content;"> <div style="text-align: right;">12.3 %</div> # ERROR OUT MODE P.OUT <u>HOLD</u> </div>

Setting Contact Output Status

This function is used to set contact output status for normal operation.

This function is effective only when contact output has been selected in the function specification.

Set range:CLOSE Sets the open collector output to ON.

OPEN Sets the open collector output to OFF.

Default:OPEN

Set the contact output status in accordance with the following procedure.

— CAUTION —

You have only ten minutes to return to MEASURING MODE to save the new value before the system resets it to the previously saved value.

Step	Procedure	Screen
1	Enter ENGINEERING MODE (see “Entering Engineering Mode and Maintenance Mode” on page 82). Then press the ↑ or ↓ key to display the screen at right.	<div style="border: 1px solid black; padding: 5px; width: fit-content;"> <div style="text-align: right;">12.3 %</div> # ST. OUT MODE NORMAL <u>CLOSE</u> </div>
2	Press the → key.	<div style="border: 1px solid black; padding: 5px; width: fit-content;"> <div style="text-align: right;">12.3 %</div> # ST. OUT MODE NORMAL <u>CLOSE</u> </div>
3	Using the ↑ key, set the contact output status.	<div style="border: 1px solid black; padding: 5px; width: fit-content;"> <div style="text-align: right;">12.3 %</div> # ST. OUT MODE NORMAL <u>OPEN</u> </div>

Step	Procedure	Screen
4	Press the → key to move the cursor to the position under #. Press the MODE key to return to the MEASURING MODE and to save data.	<div style="border: 1px solid black; padding: 5px; width: fit-content;"> <div style="text-align: right;">12.3 %</div> # ST. OUT MODE NORMAL OPEN </div>

Configuration of Maintenance Mode

The Maintenance Mode is used when adjustments and checks are needed for regular maintenance and when troubles occur. Adjustments and checks are allowed only at write protect level 0.

This mode is divided into the following three types: OUTPUT CHECK MODE, CALIBRATION MODE, and CRITICAL MODE.

— CAUTION —

CALIBRATION MODE and CRITICAL MODE contains very important adjustment values or operations for the flow rate measurement. Wrong settings make accurate flow rate measurement impossible. For the operation, contact Invensys.

— CAUTION —

When the mode is changed to MEASURING MODE by pressing the **MODE** key, the set/changed data are saved into a non-volatile memory. Be sure to press the **MODE** key, to save the configured data.

— CAUTION —

Set or changed data are temporarily written into the memory. Note that if the configured data are not saved/written into the memory within 10 minutes, the configured data returns to the previous values. Be sure to press the **MODE** key to return to the MEASURING MODE and to save data.

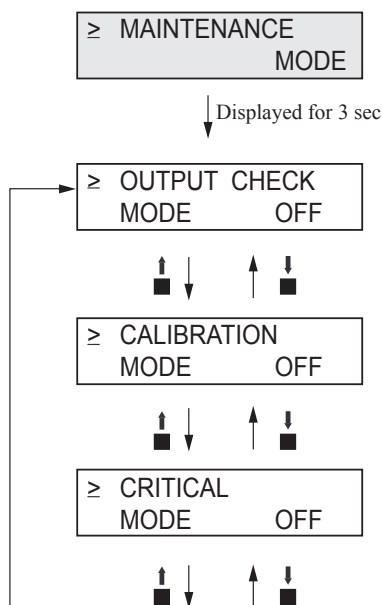
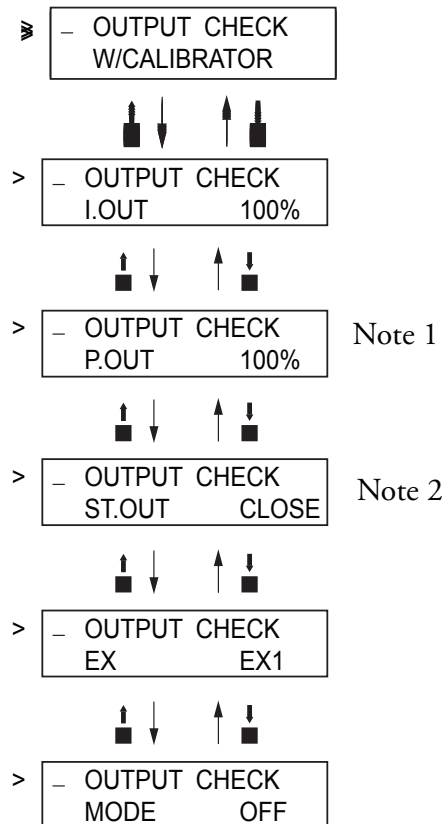

Figure 57. Maintenance Mode Menu Tree

Configuration of Output Check Mode

OUTPUT CHECK MODE has the following setting and adjustment items.

Item	Content	Screen
OUTPUT CHECK W/CALIBRATOR	Perform loop checks by using a calibrator.	<div style="border: 1px solid black; padding: 5px; width: fit-content;"> ≥ 12.3 % OUTPUT CHECK W/CALIBRATOR </div>
OUTPUT CHECK I.OUT	Outputs a fixed value of analog current output to perform loop checks.	<div style="border: 1px solid black; padding: 5px; width: fit-content;"> ≥ 12.3 % OUTPUT CHECK I.OUT 100% </div>
OUTPUT CHECK P.OUT	Outputs a fixed value of pulse output to perform loop checks.	<div style="border: 1px solid black; padding: 5px; width: fit-content;"> ≥ 12.3 % OUTPUT CHECK P.OUT 100% </div>
OUTPUT CHECK ST.OUT	Outputs a fixed value of contact output to perform loop checks.	<div style="border: 1px solid black; padding: 5px; width: fit-content;"> ≥ 12.3 % OUTPUT CHECK ST.OUT CLOSE </div>
OUTPUT CHECK EX	Outputs a fixed value of excitation current. This value was calibrated in the factory. Do not configure this value.	<div style="border: 1px solid black; padding: 5px; width: fit-content;"> ≥ 12.3 % OUTPUT CHECK EX EX1 </div>

**NOTES**

1. Displayed only when PULSE is selected by FUNCSET in ENGINEERING MODE.
2. Displayed only when HI LO STOUT or ELECTRODE STOUT is selected in ENGINEERING MODE.

Figure 58. Output Check Mode Menu Tree

Performing Loop Checks of Analog Outputs by Using a Calibrator

NOTE

For use by Invensys personnel only.

Analog Output Check

With the signal input by a calibrator, the electromagnetic flowmeter outputs a 4 to 20 mA signal to perform the loop check. Other instruments in the analog current output loop, such as recorders and controllers can be checked.

Default Setting

Signal input by the calibrator.

Setting Range

0%, 25% to 100%. (The % flow rate input from 1% to 24% are not available).

Perform loop checks of analog outputs by using a calibrator in accordance with the following procedures.

Step	Procedure	Screen
1	Enter MAINTENANCE MODE (see “Entering Engineering Mode and Maintenance Mode” on page 82). Then the screen at right is displayed.	<div style="border: 1px solid black; padding: 5px; width: fit-content;"> <div style="text-align: right;">20.0 %</div> <div>≥ OUTPUT CHECK MODE OFF</div> </div>
2	Press the → key to move the cursor to the OFF position. Press the ↑ key. With the display switched from OFF to ON , the output check mode is then active.	<div style="border: 1px solid black; padding: 5px; width: fit-content;"> <div style="text-align: right;">20.0 %</div> <div>> OUTPUT CHECK MODE OFF</div> </div> <div style="border: 1px solid black; padding: 5px; width: fit-content;"> <div style="text-align: right;">20.0 %</div> <div>> OUTPUT CHECK MODE ON</div> </div> <div style="border: 1px solid black; padding: 5px; width: fit-content;"> <div style="text-align: right;">20.0 %</div> <div>≥ OUTPUT CHECK W/CALIBRATOR</div> </div>
3	Input the signal from the calibrator and perform the loop check.	<div style="border: 1px solid black; padding: 5px; width: fit-content;"> <div style="text-align: right;">20.0 %</div> <div>≥ OUTPUT CHECK W/CALIBRATOR</div> </div>

Performing Loop Checks of Analog Outputs

Analog Output Check

The electromagnetic flowmeter can be used as a constant current generator to check analog outputs. Other instruments in the analog current output loop, such as recorders and controllers can be checked.

Default Setting

Displays the current output value.

Setting Range

Range settings are allowed ranging from 0 to 100%.

Perform loop checks of analog outputs in accordance with the following procedure.

Step	Procedure	Screen
1	Enter MAINTENANCE MODE (see “Entering Engineering Mode and Maintenance Mode” on page 82). Then display the screen at right.	<div style="border: 1px solid black; padding: 5px; width: fit-content;"> <div style="text-align: right;">20.0 %</div> <div style="text-align: right;">≥ OUTPUT CHECK</div> <div style="text-align: right;">MODE OFF</div> </div>
2	Press the → key to move the cursor to the OFF position. Press the ↑ key. With the display switched from OFF to ON , the output check mode is then active.	<div style="border: 1px solid black; padding: 5px; width: fit-content;"> <div style="text-align: right;">20.0 %</div> <div style="text-align: right;">> OUTPUT CHECK</div> <div style="text-align: right;">MODE OFF</div> </div> <div style="border: 1px solid black; padding: 5px; width: fit-content;"> <div style="text-align: right;">20.0 %</div> <div style="text-align: right;">> OUTPUT CHECK</div> <div style="text-align: right;">MODE ON</div> </div> <div style="border: 1px solid black; padding: 5px; width: fit-content;"> <div style="text-align: right;">20.0 %</div> <div style="text-align: right;">≥ OUTPUT CHECK</div> <div style="text-align: right;">W/CALIBRATOR</div> </div> <div style="border: 1px solid black; padding: 5px; width: fit-content;"> <div style="text-align: right;">20.0 %</div> <div style="text-align: right;">≥ OUTPUT CHECK</div> <div style="text-align: right;">I.OUT 000.0%</div> </div>
3	Press the → key to move the cursor to the position under a desired value to be checked.	<div style="border: 1px solid black; padding: 5px; width: fit-content;"> <div style="text-align: right;">20.0 %</div> <div style="text-align: right;">> OUTPUT CHECK</div> <div style="text-align: right;">I.OUT 000.0%</div> </div>
4	Pressing the ↑ or ↓ key, change the value to the desired value to be checked. As shown on the screen on the right, the output to the range, given as an analog output, is 100% (20 mA).	<div style="border: 1px solid black; padding: 5px; width: fit-content;"> <div style="text-align: right;">20.0 %</div> <div style="text-align: right;">> OUTPUT CHECK</div> <div style="text-align: right;">I.OUT 100.0%</div> </div>
5	Press the → key to move the cursor to the position under >. Movement to another screen by using the ↑ or ↓ key returns to an analog output according to the actual flow rate.	<div style="border: 1px solid black; padding: 5px; width: fit-content;"> <div style="text-align: right;">20.0 %</div> <div style="text-align: right;">≥ OUTPUT CHECK</div> <div style="text-align: right;">I.OUT 100.0%</div> </div>

Performing Loop Checks of Pulse Outputs

Pulse Output Check

The electromagnetic flowmeter can be used as a pulse generator to check pulse outputs.

This screen appears when pulse output has been selected in **FUNC SET** of ENGINEERING MODE (see “Selecting Pulse Output, Electrode Status Output, or High Low Status Output” on page 88).

Default Setting

Displays the current output value.

Setting Range

Range settings are allowed ranging from 0 to 100%.

Perform loop checks of pulse outputs in accordance with the following procedure.

Step	Procedure	Screen
1	Enter MAINTENANCE MODE (see “Entering Engineering Mode and Maintenance Mode” on page 82). Then display the screen at right.	<div style="border: 1px solid black; padding: 5px; width: fit-content;"> <div style="text-align: right;">20.0 %</div> ≥ OUTPUT CHECK MODE OFF </div>
2	Press the → key to move the cursor to the OFF position. Press the ↑ key. With the display switched from OFF to ON , the output check mode is then active.	<div style="border: 1px solid black; padding: 5px; width: fit-content;"> <div style="text-align: right;">20.0 %</div> > OUTPUT CHECK MODE <u>OFF</u> </div> <div style="border: 1px solid black; padding: 5px; width: fit-content;"> <div style="text-align: right;">20.0 %</div> > OUTPUT CHECK MODE <u>ON</u> </div> <div style="border: 1px solid black; padding: 5px; width: fit-content;"> <div style="text-align: right;">20.0 %</div> ≥ OUTPUT CHECK I.OUT 000.0% </div>
3	Press the ↑ key to display the screen at right.	<div style="border: 1px solid black; padding: 5px; width: fit-content;"> <div style="text-align: right;">20.0 %</div> ≥ OUTPUT CHECK P.OUT 000.0% </div>
4	Press the → key to move the cursor to the position under a desired value to be checked.	<div style="border: 1px solid black; padding: 5px; width: fit-content;"> <div style="text-align: right;">20.0 %</div> > OUTPUT CHECK P.OUT <u>000.0%</u> </div>
5	Pressing the ↑ or ↓ key, change the value to the desired value to be checked. On the screen at right, a frequency pulse corresponding to flow rate signal 100% is output.	<div style="border: 1px solid black; padding: 5px; width: fit-content;"> <div style="text-align: right;">20.0 %</div> > OUTPUT CHECK I.OUT <u>100.0%</u> </div>
6	Press the → key to move the cursor to the position shown on the screen at right. Movement to another screen by using the ↑ or ↓ key returns to a pulse output according to the actual flow rate.	<div style="border: 1px solid black; padding: 5px; width: fit-content;"> <div style="text-align: right;">20.0 %</div> ≥ OUTPUT CHECK I.OUT 100.0% </div>

Performing Loop Checks of Contact Outputs

Contact Output Check

Contact outputs of electromagnetic flowmeter can be turned on and off to perform loop checks of contact output signals.

This screen appears when contact output has been selected in **FUNC SET** of ENGINEERING MODE (see “Selecting Pulse Output, Electrode Status Output, or High Low Status Output” on page 88).

Default Setting

Displays the current contact output status.

Setting Range

Set range **CLOSE** and **OPEN**

Perform loop checks of contact outputs in accordance with the following procedure.

Step	Procedure	Screen
1	Enter MAINTENANCE MODE (see “Entering Engineering Mode and Maintenance Mode” on page 82). Then display the screen at right.	<div style="border: 1px solid black; padding: 5px; width: fit-content;"> <div style="text-align: right;">20.0 %</div> <div>≥ OUTPUT CHECK</div> <div>MODE OFF</div> </div>
2	Press the → key to move the cursor to the OFF position. Press the ↑ key. With the display switched from OFF to ON , the output check mode is then active.	<div style="border: 1px solid black; padding: 5px; width: fit-content;"> <div style="text-align: right;">20.0 %</div> <div>> OUTPUT CHECK</div> <div>MODE <u>OFF</u></div> </div> <div style="border: 1px solid black; padding: 5px; width: fit-content;"> <div style="text-align: right;">20.0 %</div> <div>> OUTPUT CHECK</div> <div>MODE <u>ON</u></div> </div> <div style="border: 1px solid black; padding: 5px; width: fit-content;"> <div style="text-align: right;">20.0 %</div> <div>≥ OUTPUT CHECK</div> <div>I.OUT 000.0%</div> </div>
3	Press the ↑ key twice to display the screen at right. In this status, a contact output corresponding to the display is output.	<div style="border: 1px solid black; padding: 5px; width: fit-content;"> <div style="text-align: right;">20.0 %</div> <div>≥ OUTPUT CHECK</div> <div>ST.OUT CLOSE</div> </div>
4	Press the → key to move the cursor to the OPEN or CLOSE position that indicates the status of contact output.	<div style="border: 1px solid black; padding: 5px; width: fit-content;"> <div style="text-align: right;">20.0 %</div> <div>> OUTPUT CHECK</div> <div>ST.OUT <u>CLOSE</u></div> </div>

Step	Procedure	Screen
5	Press the → key to move the cursor to the position under >. Movement to another screen by using the ↑ or ↓ key returns the contact output to the output status according to the current status.	<div style="border: 1px solid black; padding: 5px; width: fit-content;"> <div style="text-align: right;">12.3 %</div> ≥ OUTPUT CHECK ST.OUT CLOSE </div>

Configuration of Calibration Mode

CALIBRATION MODE has the following setting and adjustment items:

Configuration of CALIBRATION MODE requires a dedicated calibrator.

Wrong operation may hinder accurate measurements of the flow rate. To operate in this mode, contact Invensys.

Item	Content	Screen
CAL EX LOW 3.5 mA	Adjusts 3.5 mA excitation current.	<div style="border: 1px solid black; padding: 5px; width: fit-content;"> <div style="text-align: right;">12.3 %</div> ≥ CAL EX OFF LOW 3.5 mA </div>
CAL EX 4.9 mA	Adjusts 4.9 mA excitation current.	<div style="border: 1px solid black; padding: 5px; width: fit-content;"> <div style="text-align: right;">12.3 %</div> ≥ CAL EX OFF 4.9 mA </div>
CAL EX 7.0 mA	Adjusts 7.0 mA excitation current.	<div style="border: 1px solid black; padding: 5px; width: fit-content;"> <div style="text-align: right;">12.3 %</div> ≥ CAL EX OFF 7.0 mA </div>
CAL EX 11.9 mA	Adjusts 11.9 mA excitation current.	<div style="border: 1px solid black; padding: 5px; width: fit-content;"> <div style="text-align: right;">12.3 %</div> ≥ CAL EX OFF 11.9 mA </div>
CAL EX 14.0 mA	Adjusts 14.0 mA excitation current.	<div style="border: 1px solid black; padding: 5px; width: fit-content;"> <div style="text-align: right;">12.3 %</div> ≥ CAL EX OFF 14.0 mA </div>
CAL I.OUT LOW 4.000 mA	Adjusts 4 mA analog current output.	<div style="border: 1px solid black; padding: 5px; width: fit-content;"> <div style="text-align: right;">12.3 %</div> ≥ CAL I.OUT OFF LOW 4.000 mA </div>
CAL I.OUT HIGH 20.00 mA	Adjusts 20 mA analog current output.	<div style="border: 1px solid black; padding: 5px; width: fit-content;"> <div style="text-align: right;">12.3 %</div> ≥ CAL I.OUT OFF HIGH 20.000 mA </div>

Item	Content	Screen
CAL P.OUT FREQ 90 Hz	Adjusts 90 Hz pulse output.	<div style="border: 1px solid black; padding: 5px; width: fit-content;"> <div style="text-align: right;">12.3 %</div> <div style="display: flex; justify-content: space-between;"> ≥ CAL P.OUT OFF </div> <div style="display: flex; justify-content: space-between;"> FREQ 90 Hz </div> </div>
CAL GAIN ZERO	Adjusts 0 m/s gain.	<div style="border: 1px solid black; padding: 5px; width: fit-content;"> <div style="text-align: right;">12.3 %</div> <div style="display: flex; justify-content: space-between;"> ≥ CAL GAIN OFF </div> <div style="display: flex; justify-content: space-between;"> ZERO READY </div> </div>
CAL GAIN 2.5 m/s	Adjusts 2.5 m/s gain.	<div style="border: 1px solid black; padding: 5px; width: fit-content;"> <div style="text-align: right;">12.3 %</div> <div style="display: flex; justify-content: space-between;"> ≥ CAL GAIN OFF </div> <div style="display: flex; justify-content: space-between;"> 2.5 m/s READY </div> </div>
CAL GAIN 10.0 m/s	Adjusts 10.0 m/s gain.	<div style="border: 1px solid black; padding: 5px; width: fit-content;"> <div style="text-align: right;">12.3 %</div> <div style="display: flex; justify-content: space-between;"> ≥ CAL GAIN OFF </div> <div style="display: flex; justify-content: space-between;"> 10.0 m/s READY </div> </div>
MANUAL ZERO1	Fine zero tuning for excitation current 4.9mA.	<div style="border: 1px solid black; padding: 5px; width: fit-content;"> <div style="text-align: right;">0.1 %</div> <div style="display: flex; justify-content: space-between;"> ≥ MANUAL ZERO1 </div> <div style="display: flex; justify-content: space-between;"> READY </div> </div>
MANUAL ZERO2	Fine zero tuning for excitation current 7.0mA.	<div style="border: 1px solid black; padding: 5px; width: fit-content;"> <div style="text-align: right;">0.1 %</div> <div style="display: flex; justify-content: space-between;"> ≥ MANUAL ZERO2 </div> <div style="display: flex; justify-content: space-between;"> READY </div> </div>
MANUAL ZERO3	Fine zero tuning for excitation current 11.9mA/14.0mA.	<div style="border: 1px solid black; padding: 5px; width: fit-content;"> <div style="text-align: right;">0.1 %</div> <div style="display: flex; justify-content: space-between;"> ≥ MANUAL ZERO3 </div> <div style="display: flex; justify-content: space-between;"> READY </div> </div>

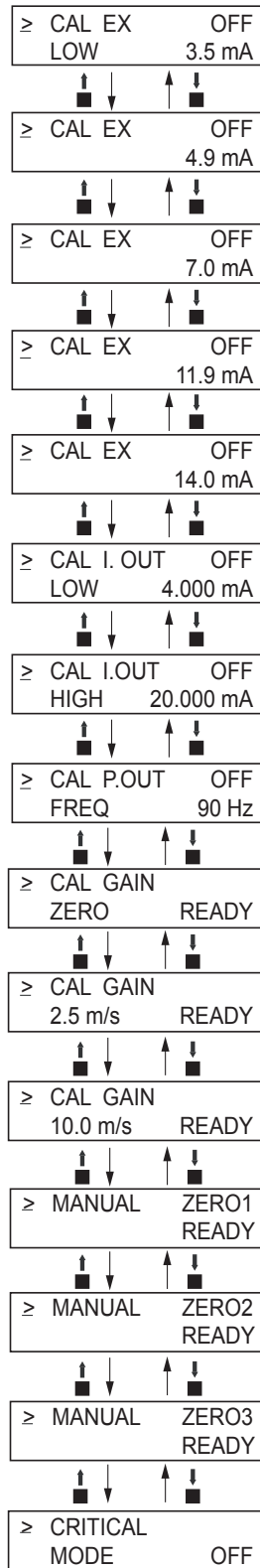

Figure 59. Calibration Mode Menu Tree

Manual Zero

This function is used to improve flow measurement more accurately when the flow rate becomes 25% or less of setting range.

The MAG2 Flowmeter has three manual zeroing functions for each excitation current.

MANUAL ZERO1: Zeroing for the excitation current 4.9 mA.

MANUAL ZERO2: Zeroing for the excitation current 7.0 mA

MANUAL ZERO3: Zeroing for the excitation current 11.9 mA/14.0 mA.

Make sure the flowtube is filled with the process fluid and stands still.

Before manual zeroing, execute auto zero.

Step	Procedure	Screen
1	Enter CALIBRATION MODE. Use ↑ or ↓ key to cycle through the screens until the MANUAL ZERO1 screen appears.	<div style="border: 1px solid black; padding: 5px; width: fit-content;"> <div style="text-align: right;">0.5 %</div> <div style="text-align: right;">≥ MANUAL ZERO1</div> <div style="text-align: right;">READY</div> </div>
2	WORKING is flashing for approximately 20 seconds. Wait until READY appears.	<div style="border: 1px solid black; padding: 5px; width: fit-content;"> <div style="text-align: right;">0.5 %</div> <div style="text-align: right;">≥ MANUAL ZERO1</div> <div style="text-align: right;">WORKING</div> </div>
3	Check the value of zero point. If 0.0% is displayed on the main display, MANUAL ZEROING is not necessary for MANUAL ZERO1. If the value of zero point is not 0.0%, adjust the zero point.	<div style="border: 1px solid black; padding: 5px; width: fit-content;"> <div style="text-align: right;">0.5 %</div> <div style="text-align: right;">≥ MANUAL ZERO1</div> <div style="text-align: right;">READY</div> </div>
4	Move the cursor under READY by pushing the → key.	<div style="border: 1px solid black; padding: 5px; width: fit-content;"> <div style="text-align: right;">0.5 %</div> <div style="text-align: right;">> MANUAL ZERO1</div> <div style="text-align: right;">READY</div> </div>

— NOTE —

If the main display shows -2.0%, the zero point value may exceed -2.0%. Execute Auto zero before Manual zero.

Step	Procedure	Screen
5	<p>Adjust zero point by pushing the ↑ or ↓ key so that the main display shows 0.0%. By pushing the ↑ key once, READY changes to UP and the zero point value increases 0.05%. By pushing the ↓ key once, READY changes to DOWN and the zero point value decreases 0.05%. It takes about 20 seconds to change the zero point value. During manual zeroing, the value in the main display flashes. If you push the ↑ or ↓ key again, wait until the value in the main display does not flash.</p> <p>Note <i>Do not keep on pushing the ↑ or ↓ key. Manual zeroing does not work.</i></p>	<div data-bbox="1154 304 1442 409" style="border: 1px solid black; padding: 5px; margin-bottom: 20px;"> <p style="text-align: right;">0.0 %</p> <p>> MANUAL ZERO1 READY</p> </div> <div data-bbox="1154 945 1442 1050" style="border: 1px solid black; padding: 5px; margin-bottom: 20px;"> <p style="text-align: right;">0.0 %</p> <p>> MANUAL ZERO1 UP</p> </div> <div data-bbox="1154 1102 1442 1207" style="border: 1px solid black; padding: 5px;"> <p style="text-align: right;">0.0 %</p> <p>> MANUAL ZERO1 DOWN</p> </div>
6	Move the cursor to the mode indicator by pushing → key.	<div data-bbox="1154 1260 1442 1365" style="border: 1px solid black; padding: 5px;"> <p style="text-align: right;">0.0 %</p> <p>≥ MANUAL ZERO1 READY</p> </div>
7	Push the ↓ key and display the MANUAL ZERO2 screen.	<div data-bbox="1154 1417 1442 1522" style="border: 1px solid black; padding: 5px;"> <p style="text-align: right;">0.5 %</p> <p>≥ MANUAL ZERO2 WORKING</p> </div>
8	Execute MANUAL ZERO2, as well as MANUAL ZERO1. (Refer to the Step 2 to 6.)	<div data-bbox="1154 1575 1442 1680" style="border: 1px solid black; padding: 5px;"> <p style="text-align: right;">0.0 %</p> <p>≥ MANUAL ZERO2 WORKING</p> </div>
9	Push the ↓ key and display the MANUAL ZERO3 screen.	<div data-bbox="1154 1732 1442 1837" style="border: 1px solid black; padding: 5px;"> <p style="text-align: right;">0.5 %</p> <p>≥ MANUAL ZERO3 WORKING</p> </div>

Step	Procedure	Screen
10	Execute MANUAL ZERO3, as well as MANUAL ZERO1. (Refer to the Step 2 to 6.)	<div style="border: 1px solid black; padding: 5px; text-align: center;"> 0.0 % ≥ MANUAL ZERO3 WORKING </div>
11	Push the MODE key and return to the MEASURING MODE.	<div style="border: 1px solid black; padding: 5px; text-align: center;"> 0.5 % MEASURING MODE </div>

Configuration of Critical Mode

CRITICAL MODE has the following setting and adjustment items.

Item	Content	Screen
ROM VER DATE	Displays the ROM version and date.	<div style="border: 1px solid black; padding: 5px; text-align: center;"> 20.0 % ≥ ROM VER. [] [] DATE YY-MM-DD </div>
SHIPPING DATA (default value) RECOVERY	<p>You can return the device to factory setting/default values for pertinent operational and configuration parameters.</p> <p>These parameters are entered before the device is shipped, so they are commonly referred to as “shipping data”.</p> <p>They include factory calibration data and factory settings or initial default settings for customer configuration data.</p>	<div style="border: 1px solid black; padding: 5px; text-align: center;"> 20.0 % ≥ SHIPPING DATA RECOVERY READY </div>
INITIAL DATA RECOVERY	<p>Initial data recovery eliminates all calibration data and configuration parameters.</p> <p>For Invensys use only.</p>	<div style="border: 1px solid black; padding: 5px; text-align: center;"> 20.0 % ≥ INITIAL DATA RECOVERY READY </div>

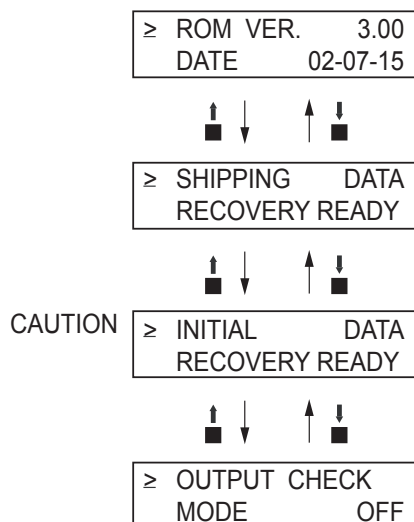

Figure 60. Critical Mode Menu Tree

—  **CAUTION** —

INITIAL DATA RECOVERY function is only for an Invensys service/maintenance specialist. Please do **not** use this function. If this function is turned **ON**, all calibrated data will be missing. The device needs to be back to the factory to calibrate again.

Displaying ROM Version and Date

The ROM version and date of the transmitter can be displayed on the display screen.

Display the ROM version and data in accordance with the following procedure.

Step	Procedure	Screen
1	Enter MAINTENANCE MODE (see “Entering Engineering Mode and Maintenance Mode” on page 82). Using the ↑ or ↓ key, display the screen at right.	<div style="border: 1px solid black; padding: 5px; width: fit-content;"> 20.0 % ≥ OUTPUT CHECK MODE OFF </div>
2	Press the ↑ key twice to display the screen at right.	<div style="border: 1px solid black; padding: 5px; width: fit-content;"> 20.0 % ≥ CRITICAL MODE OFF </div>
3	Press the → key to move the cursor to the OFF position. Then press the ↑ key to switch the display from OFF to ON .	<div style="border: 1px solid black; padding: 5px; width: fit-content;"> 20.0 % > CRITICAL MODE <u>ON</u> </div>

Step	Procedure	Screen
4	After the entry into CRITICAL MODE, the screen at right appears. On the screen, the ROM version and date can be checked.	<div style="border: 1px solid black; padding: 5px; width: fit-content;"> <div style="text-align: right;">20.0 %</div> ≥ ROM VER. DATE YY-MM-DD </div>

Returning to Settings at Shipment

Performing SHIPPING DATA RECOVERY returns the internal data settings of the device to the settings at time of shipment.

Note that executing this operation erases the data that was set and changed by the customer.

Perform SHIPPING DATA RECOVERY in accordance with the following procedure.

Step	Procedure	Screen
1	Enter MAINTENANCE MODE (see “Entering Engineering Mode and Maintenance Mode” on page 82). Using the ↑ or ↓ key, display the screen at right.	<div style="border: 1px solid black; padding: 5px; width: fit-content;"> <div style="text-align: right;">20.0 %</div> ≥ OUTPUT CHECK MODE OFF </div>
2	Press the ↑ key twice to display the screen at right.	<div style="border: 1px solid black; padding: 5px; width: fit-content;"> <div style="text-align: right;">20.0 %</div> ≥ CRITICAL MODE OFF </div>
3	Press the → key to move the cursor to the OFF position. Then press the ↑ key to switch the display from OFF to ON . After the entry into CRITICAL MODE, the screen at right appears.	<div style="border: 1px solid black; padding: 5px; width: fit-content;"> <div style="text-align: right;">20.0 %</div> > CRITICAL MODE <u>ON</u> </div> <div style="border: 1px solid black; padding: 5px; width: fit-content;"> <div style="text-align: right;">20.0 %</div> ≥ ROM VER. DATE YY-MM-DD </div>
4	Press the ↑ key to display the screen at right.	<div style="border: 1px solid black; padding: 5px; width: fit-content;"> <div style="text-align: right;">20.0 %</div> ≥ SHIPPING DATA RECOVERY READY </div>
5	Press the → key to move the cursor to the READY position, and then keep pressing the ↑ key for three seconds or more.	<div style="border: 1px solid black; padding: 5px; width: fit-content;"> <div style="text-align: right;">20.0 %</div> > SHIPPING DATA RECOVERY <u>READY</u> </div>

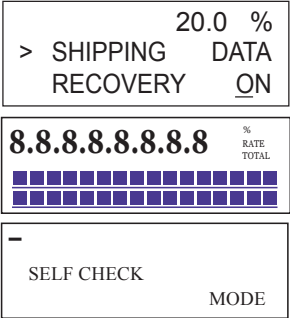
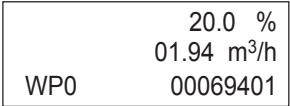
Step	Procedure	Screen
6	SHIPPING DATA RECOVER starts. The display changes as shown on the screen at right.	
7	When SHIPPING DATA RECOVERY ends, the data settings return to those at the time of shipping, and then the MEASURING MODE screen reappears.	

Description of Error Messages

Errors are classified into critical failure and non-critical failure.

Critical Failure

Critical failure may obstruct the electromagnetic flowmeter operation, if not corrected, ultimately damage the flowmeter. When critical failure occurs during operation, an error message appears on the transmitter display and the electromagnetic flowmeter continues to output the preset value in the abnormality treatment (failsafe) direction. The error message and the self-diagnostic results are visible on the display.

Perform the proper correction measures, referring to the actions below.

Error Code of Serious Trouble

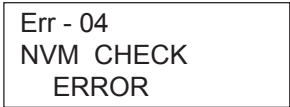
Error code	Error content	Action	LCD display
Err-02	CPU (ROM, RAM) CHECK SUM ERROR	1. Restore power. 2. Replace ROM. 3. Replace main P/C.	
Err-04	NVM READ AFTER WRITE ERROR	1. Restore power. 2. Replace main P/C.	

Noncritical Error

Noncritical failures do not seriously affect electromagnetic flowmeter operation. When an error occurs during operation and is regarded as a noncritical problem by the transmitter self-diagnostics, the output does not burn-out and the electromagnetic flowmeter continues to output the measured value.

If a wrong setting is found, an error message is displayed for a second, and then the screen set wrongly is displayed.

Error Code Of Set Errors

Error Code	Error Content	Action	LCD Display
Err-12	Upper/lower limit alarm set error HI < LO is set.	Set HI>LO.	Err - 12 SETTING ERROR HI<LO
Err-21	Span is set to 12 m/s or more.	Check the settings of flow rate range and flowtube information (bore diameter and flowtube type).	Err - 21 SPAN ERROR OVER 12 m/s
Err-22	Pulse frequency is too large or too small. The flow rate range unit system is different from the pulse unit system. Example: SPAN m ³ /h pulse scale t/h	1. Check pulse scale. 2. Check the setting of pulse frequency. 3. Adopt a unified unit system.	Err - 22 PULSE WEIGHT SETTING ERROR
Err-23	The pulse width is too large. When pulse frequency is output, the duty is 70% or more.	Check the following settings: 1. Pulse width 2. pulse scale 3. Span	Err - 23 PULSE WIDTH OVER DUTY 70%

5. Operation Via HART Communicator

Preparation for Communication, Verification and Cautions On Use

This section describes the preparation necessary for communication between a device and a HART Communicator. This section also covers the procedure to verify communication. The first step for preparation is to perform wiring between the transmitter and the HART Communicator. After wiring has been completed, turn the power on and verify that communications are functioning properly.

CAUTION
Electrode Status Diagnostic must be set to off if connection is to an asset management system or distributed control system.

Wiring Between Transmitter and HART Communicator

Connect the HART Communicator as shown in Figure 61. A 250 Ω resistor must be installed on the receiving end of the output current. There is no polarity on the HART Communicator terminal.

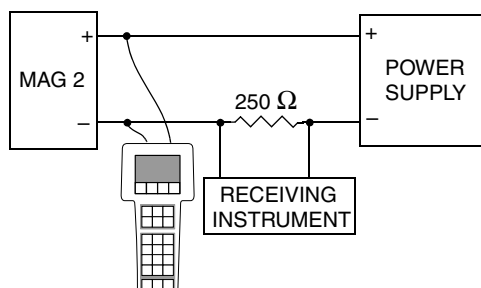

Figure 61. HART Communicator Wiring

Verifying Communication

After the HART Communicator has been properly interconnected, turn the transmitter power on. For the external power supply model, turn on the external power supply before turning the transmitter power on.

Once the setting and wiring connections are correct, the HART Communicator's display shows an online menu as shown in Figure 62 and a HART mark flickers in the upper right hand corner of the display.

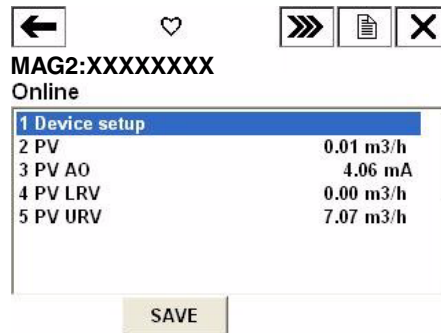

Figure 62. Online Menu

If the display is not as shown in Figure 62 but as shown in Figure 63 below, no communications are being made. Recheck the HART Communicator connections and the transmitter settings.



Figure 63. Communication Not Available

Cautions

—! CAUTION —

Do not remove the HART Communicator cable from the transmitter while executing communication. If the cable is disconnected during data setting transmission there will be no data transfer to the transmitter.

Setting and Calibrating Devices Using the HART Communicator

The HART Communicator enables the user to set a two wired magnetic flowmeter device as well as allowing them to adjust and check the output of the device and to inspect the device. The following values can be set using the HART Communicator:

- ◆ Flow unit
- ◆ Range
- ◆ Specific gravity
- ◆ Damping time constant
- ◆ Display selection
- ◆ Function selection
- ◆ Correction coefficient
- ◆ Flowtube diameter
- ◆ Flowtube constant
- ◆ Auto spike cut
- ◆ Average processing selection
- ◆ Average processing time
- ◆ Low flow cut
- ◆ Drop out
- ◆ Pulse scale unit
- ◆ Pulse scale
- ◆ Pulse width
- ◆ Totalized value of integral counter display
- ◆ Reset value of integral counter
- ◆ Integral counter reset
- ◆ High alarm value setting
- ◆ Low alarm value setting
- ◆ Setting output status setting
- ◆ Burnout (Analog output) setting
- ◆ Burnout (Pulse output) setting
- ◆ Electrode status diagnostic function

Also, the following calibrations and inspection can be made:

- ◆ Zero point adjustment
- ◆ Current output calibration at 4 mA and 20 mA
- ◆ Gain adjustment
- ◆ Pulse output adjustment
- ◆ Excitation current output adjustment
- ◆ Analog output check
- ◆ Pulse output check
- ◆ Contact output check
- ◆ Transmitter status check
- ◆ Tag setting
- ◆ Shipping data recovery
- ◆ Equipment information check

Setting procedures

The procedures to set various device values are described in this section.

Flow Units

Set the flow unit as follows.

1. Select “1. Device setup” from online menu 1 (Figure 62).
The device setup menu is then displayed. (Figure 64)

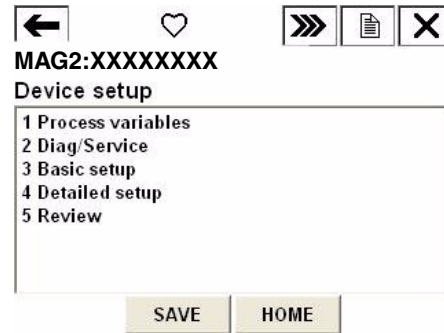

Figure 64. Device Setup Menu

2. Select “3. Basic setup” from the menu.
The basic setup menu is displayed. (Figure 65)

MAG2:XXXXXXXX

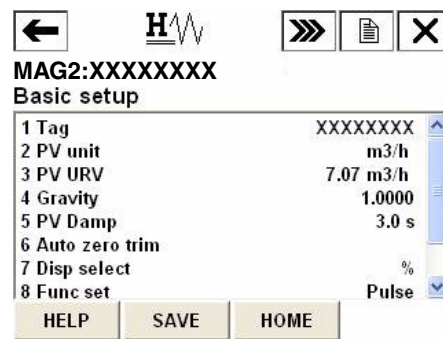

Figure 65. Basic Setup Menu

3. Select “2. PV unit” from the basic setup menu.
4. Once the display as shown in Figure 66 appears, move the arrow key up or down to select a flow unit. After making a selection, press F4 (ENTER). If F3 (ESC) is pressed here, the selection is canceled and the display returns to the basic menu.

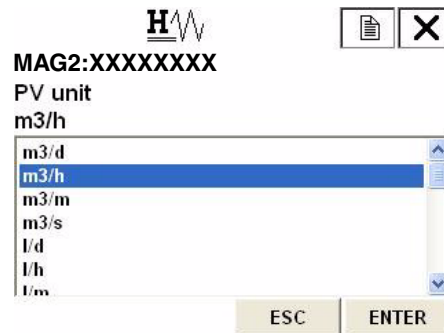

Figure 66. Selection of Flow Rate Unit

5. After pressing F4 (ENTER) and returning to the basic menu, press F2 (SEND). The HART mark appears in the upper right hand corner while HART is communicating with the device. (Figure 67.)
Once communication is completed, the HART mark disappears.

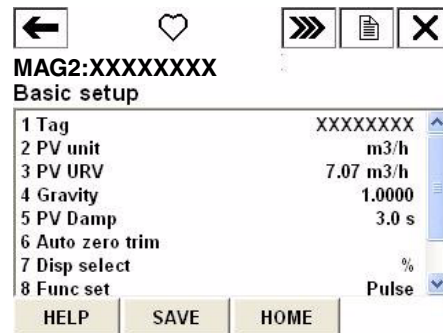

Figure 67. Transmitting the Setting

Range

Set the upper limit of the flow range as follows.

1. From online menu,
 - Select:
 - 1. Device setup
 - 3. Basic setup
 - 3. PV URV
- Figure 68 is then displayed.



Figure 68.

2. Use the numeric keys to enter a new range value in the value input display. Up to six digits including a decimal point can be entered. Setting range of the flow range is 0.3 m/s to 10 m/s in flow rate.
3. Once a new value is entered, press F4 (ENTER) to return to the basic setup menu. When the value is outside the range, an error message is displayed. Input the value again.
4. After returning to the basic setup menu, press F2 (SEND). The changed setting is sent to the transmitter. The HART Communicator mark appears on the upper right hand corner while HART is communicating with the device. Once communication is completed, the HART mark disappears.

Specific Gravity

The specific gravity, when selecting the unit of weight is set as follows.

1. From online menu,
 - Select:
 - 1. Device setup
 - 3. Basic setup
 - 4. Gravity
- Figure 69 is then displayed.

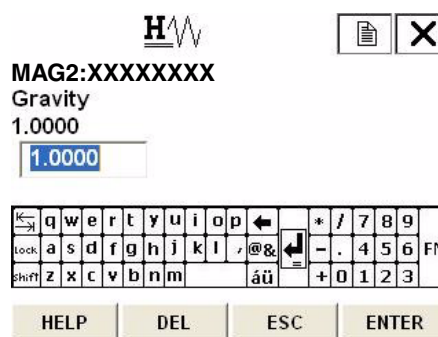

Figure 69.

2. Use the numeric keys to enter a specific gravity value in the value input display. Up to six digits including a decimal point can be entered. Setting range of the specific gravity is 0.1000 to 5.9999.

3. Once a new value is entered, press F4 (ENTER) to return to the basic setup menu. When the entered value is outside the range, an error message is displayed. Input the value again.
4. After returning to the basic setup menu, press F2 (SEND). The changed setting is sent to the transmitter. The HART Communicator mark appears on the upper right hand corner while HART is communicating with the device. Once communication is completed, the HART mark disappears.

Damping Time Constant

Set the damping time constant as follows.

1. From online menu, Select:
 1. Device setup
 - 3. Basic setup
 - 5. PV Damp
 Figure 70 is then displayed.

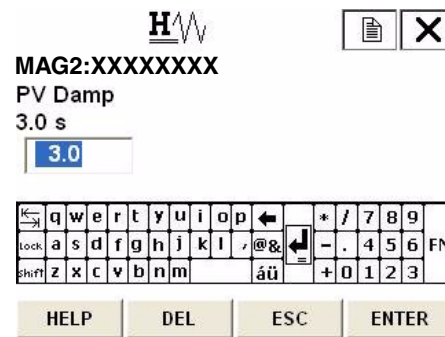

Figure 70.

2. Use the numeric keys to enter a damping time constant value in the value input display. Up to five digits including a decimal point can be entered. Setting range of the damping constant is 0.5 to 199.9.
3. Once a new value is entered, press F4 (ENTER) to return to the basic setup menu. When the value is outside the range, an error message is displayed. Input the value again.
4. After returning to the basic setup menu, press F2 (SEND). The changed setting is sent to the transmitter. The HART Communicator mark appears on the upper right hand corner while HART is communicating with the device. Once communication is completed, the HART mark disappears.

Zero Adjustment

Follow the steps described below to perform a zero adjustment.

1. Make sure that the fluid to be calibrated inside the flowmeter is static.
2. From online menu, Select:
 1. Device setup
 - 3. Basic setup
 - 6. Auto zero trim

Figure 71 is then displayed.

To adjust the zero point, press F4 (OK). It takes approximately 120 seconds to adjust the zero point.

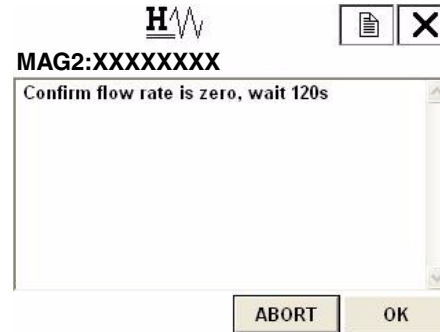

Figure 71.

3. When F4 (OK) is pressed, Figure 72 is displayed and starts adjusting the zero point. By pressing F3 (ABORT), the procedure is canceled.

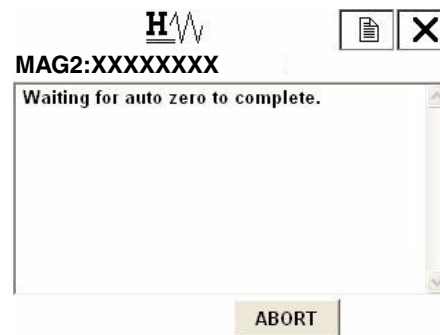

Figure 72.

4. Once zero point adjustment is completed, Figure 73 is displayed. Press F4 (OK) and return to the online menu.



Figure 73.

Selecting Display

The display selection is set as follows.

1. From online menu, Select:
 1. Device setup
 - 3. Basic setup
 - 7. Disp select
 Figure 74 is then displayed.



Figure 74.

2. Once the display as shown in Figure 74 appears, move the arrow key up or down to select a display. After making a selection, press F4 (ENTER). % /Rate /Total can be selected. If F3 (ESC) is pressed here, the selection is canceled and the display returns to the basic menu.
3. After returning to the basic setup menu, press F2 (SEND). The changed setting is sent to the transmitter. The HART Communicator mark appears on the upper right hand corner while HART is communicating with the device. Once communication is completed, the HART mark disappears.

Selecting Function

Pulse output and contact output can be selected.

Follow the procedures described below to select pulse output or contact output.

1. From online menu, Select:
 1. Device setup
 - 3. Basic setup
 - 8. Func set
 Figure 75 is then displayed.



Figure 75.

2. Once the display as shown in Figure 75. appears, move the arrow key up or down to select a display. After making a selection, press F4 (ENTER). Pulse (pulse output), Hi Lo ST out (contact output), or Electrode ST out (contact output) can be selected. If F3 (ESC) is pressed here, the selection is canceled and the display returns to the basic menu.

- After returning to the basic setup menu, press F2 (SEND). The changed setting is sent to the transmitter. The HART Communicator mark appears on the upper right hand corner while HART is communicating with the device. Once communication is completed, the HART mark disappears.

Correction Coefficient Setting

Correction coefficient multiplier can be set in to modify the output flow.

The correction coefficient is set as follows.

- From online menu,
 - Select:
 - 1. Device setup
 - 3. Basic setup
 - 9. Coefficient
 Figure 76 is then displayed.

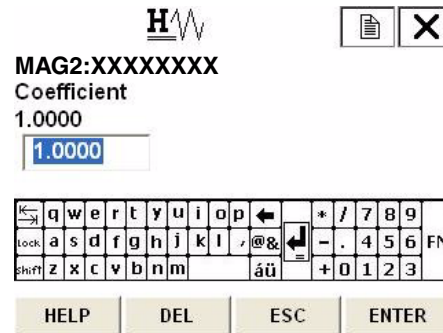

Figure 76.

- Use the numeric keys to enter a correction coefficient value in the value input display. Up to six digits including a decimal point can be entered. Setting range of correction coefficient is 0.1000 to 5.9999.
- Once a new value is entered, press F4 (ENTER) to return to the basic setup menu. When the value is outside the range, an error message is displayed. Input the value again.
- After returning to the basic setup menu, press F2 (SEND). The changed setting is sent to the transmitter. The HART Communicator mark appears on the upper right hand corner while HART is communicating with the device. Once communication is completed, the HART mark disappears.

Setting Transmitter Data

Flowtube Diameter

Follow the procedures described below to set the flowtube diameter.

Set the diameter size printed on the nameplate.

1. From online menu,
Select:
 1. Device setup
 - 4. Detailed setup
 - 1. Flowtube config
 - 1. Tube size
- Figure 77 is then displayed.

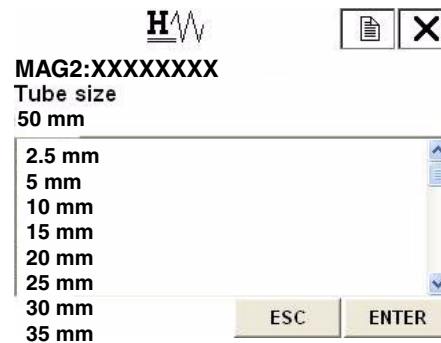

Figure 77.

2. Once the display as shown in Figure 77 appears, move the arrow key up or down to select a flowtube diameter. After making a selection, press F4 (ENTER). If F3 (ESC) is pressed here, the selection is canceled and the display returns to the flowtube config menu.
3. After returning to the flowtube config menu, press F2 (SEND). The changed setting is sent to the transmitter. The HART communicator mark appears on the upper right hand corner while HART is communicating with the device. Once communication is completed, the HART mark disappears.

Flowtube Type (For Special Flowmeter only)

Follow the procedures described below to set the flowtube type.

Use MAG2 at normal measurement.

1. From online menu,
Select:
 1. Device setup
 - 4. Detailed setup
 - 1. Flowtube config
 - 2. Flowtube type

Figure 78 is then displayed.

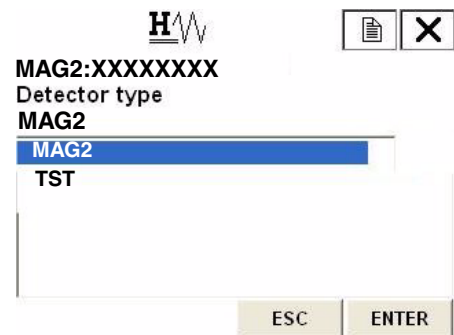

Figure 78.

2. Once the display as shown in Figure 78 appears, move the arrow key up or down to select a flowtube type. After making a selection, press F4 (ENTER). If F3 (ESC) is pressed here, the selection is canceled and the display returns to the flowtube config menu.
3. After returning to the flowtube config menu, press F2 (SEND). The changed setting is sent to the transmitter. The HART communicator mark appears on the upper right hand corner while HART is communicating with the device. Once communication is completed, the HART mark disappears.

Flowtube Constants

Follow the procedures described below to set the flowtube constant.

Set the flowtube constant (Ex value and C2 value) printed on the nameplate.

Setting Ex Value

1. From online menu, Select:
 1. Device setup
 - 4. Detailed setup
 - 1. Flowtube config
 - 3. Ex value
 Figure 79 is then displayed.



Figure 79.

2. Use the numeric keys to enter a flowtube constant in the value input display. Up to 5 digits including a decimal point can be entered. Setting range of the flowtube constant is 200.0 to 699.9. is canceled and the display returns to the flowtube config menu.
3. Once a new value is entered, press F4 (ENTER) to return to the flowtube config menu. When the value is outside the range, an error message is displayed. Input the value again.
4. After returning to the flowtube config menu, press F2 (SEND). The changed setting is sent to the transmitter. The HART communicator mark appears on the upper right hand corner while HART is communicating with the device. Once communication is completed, the HART mark disappears.

Setting C2 Value

1. From online menu, Select:
 1. Device setup
 - 4. Detailed setup
 - 1. Flowtube config
 - 4. C2 value R/W
 Figure 80 is then displayed.



Figure 80.

2. Use the numeric keys to enter a flowtube constant in the value input display. Up to 6 digit including a decimal point can be entered. Setting range of the flowtube constant C2 is 0.5000 to 1.5000.
3. Once a new value is entered, press F4 (ENTER) to return to the flowtube config menu. When the value is outside the range, an error message is displayed. Input the value again.
4. After returning to the flowtube config menu, press F2 (SEND). The changed setting is sent to the transmitter. The HART communicator mark appears on the upper right hand corner while HART is communicating with the device. Once communication is completed, the HART mark disappears.

Signal Processing

Auto Spike Cut

To set On/OFF for auto spike cut, proceed as follows.

1. From online menu, Select:
 1. Device setup
 - 4. Detailed setup
 - 3. Noise immunity
 - 2. Auto spike cut
 Figure 81 is then displayed.



Figure 81.

2. Once the display as shown in Figure 81 appears, move the arrow key up or down to select On or OFF. After making a selection, press F4 (ENTER). If F3 (ESC) is pressed here, the selection is canceled and the display returns to the Noise immunity menu.
3. After returning to the Noise immunity menu, press F2 (SEND). The changed setting is sent to the transmitter. The HART communicator mark appears on the upper right hand corner while HART is communicating with the device. Once communication is completed, the HART mark disappears.

Setting Average Processing

To set ON/OFF for average processing, proceed as follows.

1. From online menu, Select:
 1. Device setup
 - 4. Detailed setup
 - 3. Noise immunity
 - 3. Moving average
 Figure 82. is then displayed.

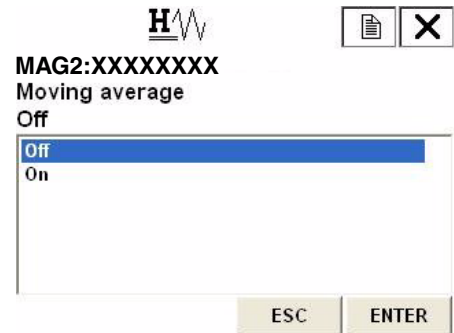

Figure 82.

2. Once the display as shown in Figure 82. appears, move the arrow key up or down to select On or Off. After making a selection, press F4 (ENTER). If F3 (ESC) is pressed here, the selection is canceled and the display returns to the Noise immunity menu.
3. After returning to the Noise immunity menu, press F2 (SEND). The changed setting is sent to the transmitter. The HART communicator mark appears on the upper right hand corner while HART is communicating with the device. Once communication is completed, the HART mark disappears.

Setting the Average Processing Time

To set the value of the average processing time, proceed as follows.

1. From online menu, Select:
 1. Device setup
 - 4. Detailed setup
 - 3. Noise immunity
 - 4. Mvng av time
 Figure 83. is then displayed.



Figure 83.

2. Use the numeric keys to enter an average processing time in the value input display. Setting range of average processing time 1.0 s to 30.0 s.
3. Once a new value is entered, press F4 (ENTER) to return to the Noise immunity menu. When the value is outside the range, an error message is displayed. Input the value again.

4. After returning to the Noise immunity menu, press F2 (SEND). The changed setting is sent to the transmitter. The HART communicator mark appears on the upper right hand corner while HART is communicating with the device. Once communication is completed, the HART mark disappears.

Low Flow Cutoff

To set the low flow cutoff, proceed as follows.

1. From online menu, Select:
 1. Device setup
 - 4. Detailed setup
 - 3. Noise immunity
 - 5. Lo flo cutoff
 Figure 84 is then displayed.

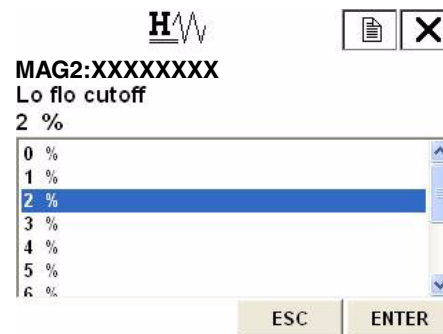

Figure 84.

2. Once the display as shown in Figure 84 appears, move the arrow key up or down to select low flow cut value. The value can be specified from 1% to 10%. After making a selection, press F4(ENTER). If F3 (ESC) is pressed here, the selection is canceled and the display returns to the Noise immunity menu.
3. After returning to the Noise immunity menu, press F2(SEND). The changed setting is sent to the transmitter. The HART communicator mark appears on the upper right hand corner while HART is communicating with the device. Once communication is completed, the HART mark disappears.

Drop-Out

When the drop-out is set to prevent the wrong integration of integrated flow rate, it does not count the pulse when it is within the flow rate of setting against the setting range.

To set the drop-out, proceed as follows.

1. From online menu,
Select:
 1. Device setup
 - 4. Detailed setup
 - 3. Noise immunity
 - 6. Drop out
 Figure 85 is then displayed.

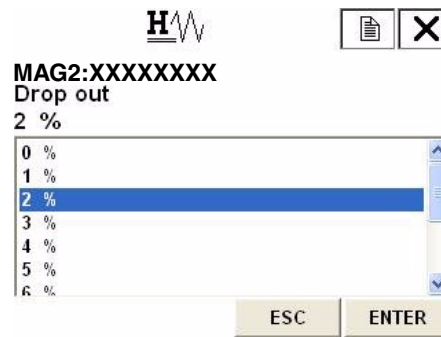

Figure 85.

2. Once the display as shown in Figure 85 appears, move the arrow key up or down to select drop-out value. The value can be specified from 0% to 10%. After making a selection, press F4(ENTER). If F3 (ESC) is pressed here, the selection is canceled and the display returns to the Noise immunity menu.
3. After returning to the Noise immunity menu, press F2(SEND). The changed setting is sent to the transmitter. The HART communicator mark appears on the upper right hand corner while HART is communicating with the device. Once communication is completed, the HART mark disappears.

Electrode Status Sensitivity

1. From online menu,
Select:
 1. Device setup
 4. Detailed setup
 3. Noise immunity
 7. Electrode status sensitivity
 Figure 86 is then displayed.

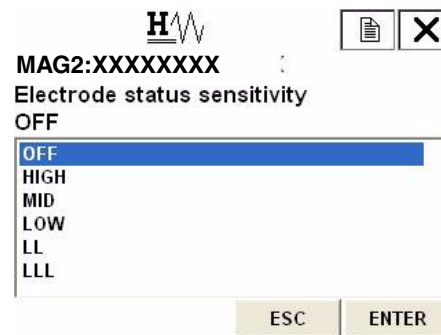

Figure 86.

2. Once the display as shown Figure 86 appears, move the arrow key up or down to select a sensitivity. After marking a selection, press F4 (ENTER). OFF, HIGH, MID, LOW, LL, or LLL can be selected. If F3 (ESC) is pressed here, the selection is canceled and the display returns to the Noise immunity menu.
3. After returning to the Noise immunity menu, press F2 (SEND). The changed setting is sent to the transmitter. The HART communicator mark appears on the upper side while HART is communicating with the device. Once communication is completed, the HART mark disappears
4. To select an appropriate sensitivity level, refer to the flow chart on page 77.

Electrode Status Output Mode

1. From online menu, Select:
 1. Device setup
 4. Detailed setup
 3. Noise immunity
 8. Electrode status output mode
 Figure 87 is then displayed.

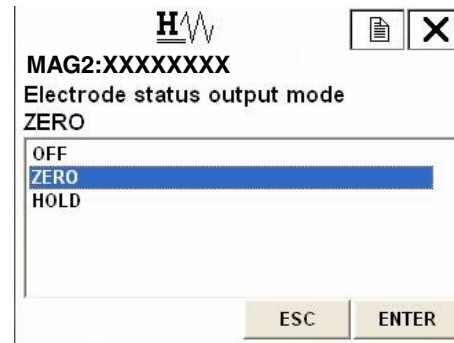

Figure 87.

2. Once the display as shown in Figure 87 appears, move the arrow key up or down to select an Electrode status output mode. After marking a selection, press F4 (ENTER). OFF, ZERO, or HOLD can be selected. If F3 (ESC) is pressed here, the selection is canceled and the display returns to the Noise immunity menu.
3. After returning to the Noise immunity menu, press F2 (SEND). The changed setting is sent to the transmitter. The HART communicator mark appears on the upper side while HART is communicating with the device. Once communication is completed, the HART mark disappears.

Pulse Setting

Pulse Scale Unit

To set the pulse scale unit, proceed as follows.

1. From online menu, Select:
 1. Device setup
 - 4. Detailed setup
 - 2. Conf output
 - 2. Pulse output
 - 1. Puls out unit
 Figure 88 is then displayed.

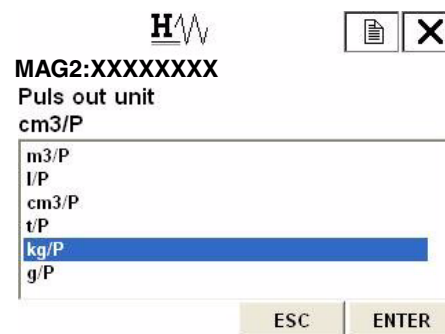

Figure 88.

2. Once the display as shown in Figure 88 appears, move the arrow key up or down to select pulse scale unit. After making a selection, press F4 (ENTER). If F3 (ESC) is pressed here, the selection is canceled and the display returns to the Pulse output menu.

- After returning to the Pulse output menu, press F2 (SEND). The changed setting is sent to the transmitter. The HART communicator mark appears on the upper right hand corner while HART is communicating with the device. Once communication is completed, the HART mark disappears.

Pulse Scale

To set the pulse scale, proceed as follows.

- From online menu, Select:
 - Device setup
 - Detailed setup
 - Conf output
 - Pulse output
 - Puls scaling

Figure 89 is then displayed.



Figure 89.

- Use the numeric keys to enter a pulse scale in the value input display. Setting range of pulse scale is span frequency of 0.0001 Hz to 200 Hz.
- Once a new value is entered, press F4 (ENTER) to return to the Noise immunity menu. When the value is outside the range, an error message is displayed. Input the value again.
- After returning to the Noise immunity menu, press F2 (SEND). The changed setting is sent to the transmitter. The HART communicator mark appears on the upper right hand corner while HART is communicating with the device. Once communication is completed, the HART mark disappears.

Pulse Width

To set the pulse width value, proceed as follows.

- From online menu, Select:
 - Device setup
 - Detailed setup
 - Conf output
 - Pulse output
 - Pulse width

Figure 90 is then displayed.

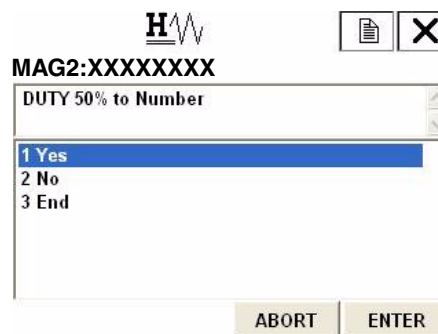

Figure 90.

2. Duty ratio is set 50%. If setting the value arbitrarily, select **Yes**, and press F4 (ENTER). If duty ratio of 50% is fine, select **No**.
3. Use the numeric keys to enter a pulse width in the value input display. Setting range of pulse width is duty ratio of 70% or less.

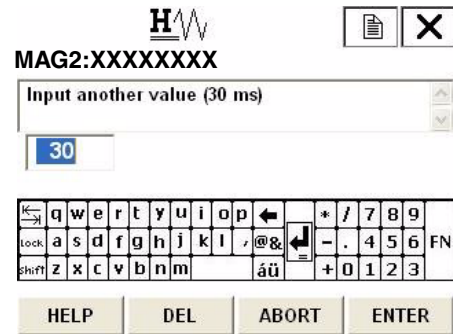

Figure 91.

4. Once a new value is entered, press F4 (ENTER). Data is transmitted. When the value is outside the range, an error message is displayed. Input the value again.

Totalized Value Setting

Displaying Totalized Value

Follow the procedures described below to display the actual totalized value.

1. From online menu, Select:
 - 1. Device setup
 - 4. Detailed setup
 - 2. Conf output
 - 3. Totalizer
 - 1. Totalizer display
 Figure 92 is then displayed.



Figure 92.

2. Press F4 (EXIT) to return to the previous display.

Integrated Reset Value

Follow the procedure described below to set the integrated reset value.

1. From online menu,
 - Select:
 1. Device setup
 - 4. Detailed setup
 - 2. Conf output
 - 3. Totalizer
 - 2. Totalizer restart val
- Figure 93 is then displayed.



Figure 93.

2. Use the numeric keys to input a integrated reset value. Integrated reset value is span frequency of 00000000 to 99999999.
3. Once a new value has been inputted, press F4 (ENTER).
4. After pressing F4 (ENTER) and returning to the Totalizer menu, press F2 (SEND) to send the change to the transmitter. The HART communication appears in the upper right hand corner while HART is communicating with the device.

Resetting the Totalized Value

Follow the procedure described below to reset the totalized value.

1. From online menu,
 - Select:
 1. Device setup
 - 4. Detailed setup
 - 2. Conf output
 - 3. Totalizer
 - 3. Reset totalizer
- Figure 94 is then displayed.



Figure 94.

2. If resetting the totalized value, select Yes, and press F4.

- After pressing F4 (ENTER), Figure 95. is then displayed. Figure 95. shows that the totalized value has been reset. After resetting, display automatically returns to the previous display in 3 seconds.



Figure 95.

Contact Output Setting

High Alarm Value Setting

To set the high alarm value of contact output, proceed as follows.

- From online menu, Select:
 - Device setup
 - 4. Detailed setup
 - 2. Conf output
 - 4. Digital output
 - 1. Hi alarm
 Figure 96 is then displayed.



Figure 96.

- Use the numeric keys to enter a high alarm value in the value input display. Setting range of high alarm value is 0% to +115%. Do not set the value to be High alarm value < Low alarm value.
- Once a new value is entered, press F4 (ENTER) to return to the Digital output menu. When the value is outside the range, an error message is displayed. Input the value again.
- After returning to the Digital output menu, press F2 (SEND). The changed setting is sent to the transmitter. The HART communicator mark appears on the upper right hand corner while HART is communicating with the device. Once communication is completed, the HART mark disappears.

Low Alarm Value Setting

To set the low alarm value of contact output, proceed as follows.

1. From online menu, Select:
 1. Device setup
 - 4. Detailed setup
 - 2. Conf output
 - 4. Digital output
 - 2. Low alarm
 Figure 97 is then displayed.

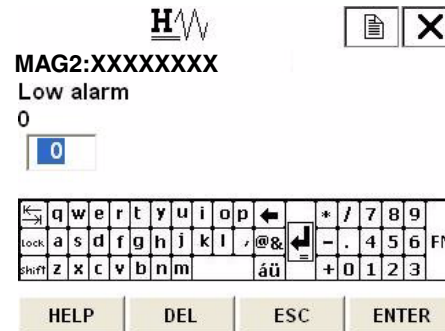

Figure 97.

2. Use the numeric keys to enter a low alarm value in the value input display. Setting range of high alarm value is 0% to +115%. Do not set the value to be High alarm value < Low alarm value.
3. Once a new value is entered, press F4 (ENTER) to return to the Digital output menu. When the value is outside the range, an error message is displayed. Input the value again.
4. After returning to the Digital output menu, press F2 (SEND). The changed setting is sent to the transmitter. The HART communicator mark appears on the upper right hand corner while HART is communicating with the device. Once communication is completed, the HART mark disappears.

Contact Output Status Setting

To select OPEN/CLOSE of contact output in normal status, proceed as follows.

1. From online menu, Select:
 1. Device setup
 - 4. Detailed setup
 - 2. Conf output
 - 4. Digital output
 - 3. Burn out DO
 Figure 98 is then displayed.



Figure 98.

2. Once the display as shown in Figure 98 appears, move the arrow key up or down to select **OPEN** or **CLOSE**. After making a selection, press F4 (ENTER). If F3 (ESC) is pressed here, the selection is canceled and the display returns to the Digital output menu.

- After returning to the Digital output menu, press F2 (SEND). The changed setting is sent to the transmitter. The HART communicator mark appears on the upper right hand corner while HART is communicating with the device. Once communication is completed, the HART mark disappears.

Burnout Setting

Analog Output Burnout Setting

To set the output direction of analog current output at critical failure, proceed as follows.

- From online menu, Select:
 - Device setup
 - Detailed setup
 - Conf output
 - Analog output
 - Burn out AO
- Figure 99 is then displayed.

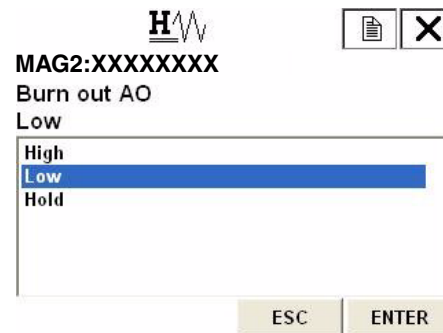

Figure 99.

- Once the display as shown in Figure 99 appears, move the arrow key up or down to select **HIGH**, **LOW**, or **HOLD**. After making a selection, press F4 (ENTER). If F3 (ESC) is pressed here, the selection is canceled and the display returns to the Analog output menu.
- After returning to the Analog output menu, press F2 (SEND). The changed setting is sent to the transmitter. The HART communicator mark appears on the upper right hand corner while HART is communicating with the device. Once communication is completed, the HART mark disappears.

Pulse Output Burnout Setting

To set the output direction of pulse output at critical failure, proceed as follows.

- From online menu, Select:
 - Device setup
 - Detailed setup
 - Conf output
 - Pulse output
 - Burn out pls

Figure 100 is then be displayed.



Figure 100.

2. Once the display as shown in Figure 100 appears, move the arrow key up or down to select **OFF** or **HOLD**. After making a selection, press F4 (ENTER). If F3 (ESC) is pressed here, the selection is canceled and the display returns to the Pulse output menu.
3. After returning to the Pulse output menu, press F2 (SEND). The changed setting is sent to the transmitter. The HART communicator mark appears on the upper right hand corner while HART is communicating with the device. Once communication is completed, the HART mark disappears.

Calibrating and Inspecting the Device by HART Communicator and Other Functions

Device Adjustment

Analog Current Output Adjustment

To adjust analog output (4 mA and 20 mA) adjustment, proceed as follows.

1. From online menu, Select:
 1. Device setup
 - 2. Diag/Service
 - 3. Calibration
 - 1. D/A trim
 Figure is then displayed.
 If the control system is not affected by the forcible change of the current signal, press F4 (OK). By pressing F3 (ABORT), the procedure is canceled.
2. Once the display as shown in Figure 102 appears, move the arrow key up or down to select a current output to adjust, and then press F4 (ENTER). This time, select 4 mA.

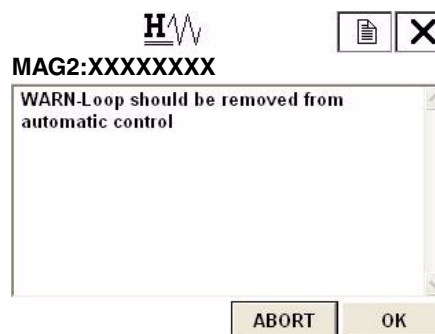

Figure 101.

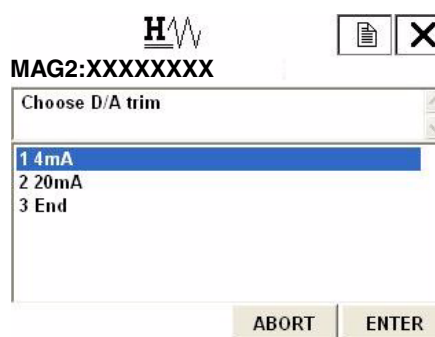

Figure 102.

- Figure 103 then appears. Connect the device to measure the current output, and then press F4 (OK).

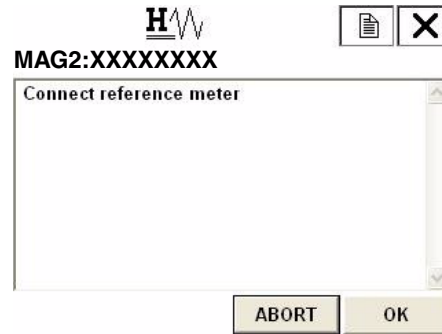

Figure 103.

- Figure 104 then appears. By pressing F4 (OK), current adjustment starts and the transmitter outputs a current corresponding to 0% of the flow range. If it is fine, press F4(OK).

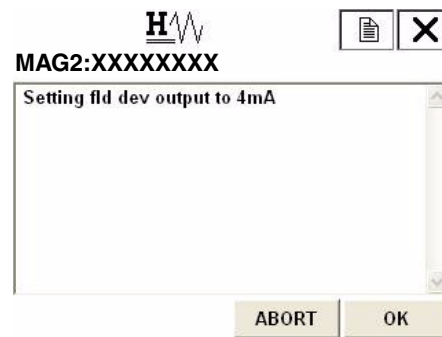

Figure 104.

- Figure 105 then appears. When executing the adjustment, select "Set", and then press F4 (ENTER).



Figure 105.

- A numerical value input display (Figure 106) then appears. Measure the output current from the transmitter and enter the current value by the mA into the device. Once the input has been completed press F4 (ENTER). The transmitter starts adjusting to 4mA automatically, and returns back to the display as shown in Figure 105. Verify that the current output value is 4 mA, and terminate the adjustment.



Figure 106.

- For 20 mA current output adjustment, follow the same procedures as shown in above.

Manual Zero

This function is used to improve flow measurement more accurately when the flow rate becomes 25% or less of setting range.

The MAG2 Flowmeter has three manual zeroing functions for each excitation current.

MANUAL ZERO1: Zeroing for the excitation current 4.9 mA.

MANUAL ZERO2: Zeroing for the excitation current 7.0 mA

MANUAL ZERO3: Zeroing for the excitation current 11.9 mA/14.0 mA.

Make sure the flowtube is filled with the process fluid and stands still.

Before manual zeroing, execute auto zero.

1. From online menu, Select:
 1. Device setup
 2. Diag/Service
 3. Calibration
 3. Manual zero
 Figure 107 is then displayed.

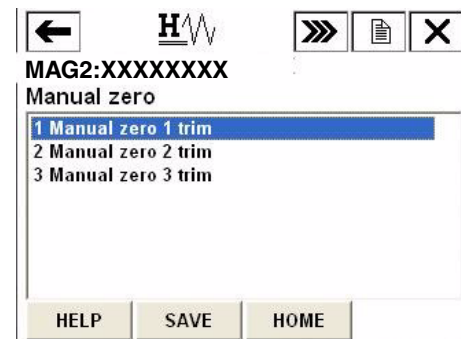

Figure 107.

2. Once the display as shown Figure 107 appears, move the arrow key up or down to select a manual zero to be adjusted.
3. Select the manual zero, then the screen as shown in Figure 108 appears.

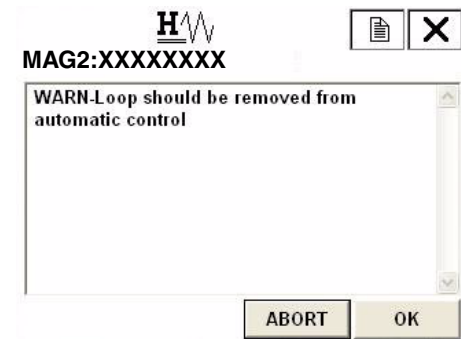

Figure 108.

4. To continue the manual zero, press OK. Then the screen as shown in Figure 109 appears. Press OK to continue. The notice as shown in Figure 110 appears.

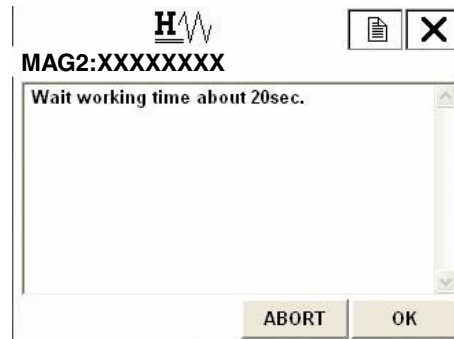

Figure 109.



Figure 110.

5. Once the display as shown Figure 111 appears, confirm the value appears on the screen and select an appropriate command by moving the arrow key up or down. After marking a selection, press F4 (ENTER). Check the adjustment value by selecting “3 Refresh %” command. If you finish the manual zero, select “4 Quit (Manual zero end) command and press F4 (ENTER). Then screen as shown in Figure 112 appears. Press OK and then the return to the Manual zero menu.

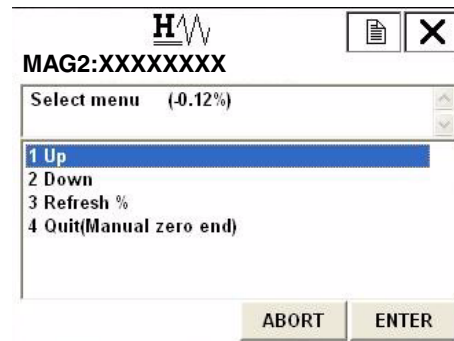

Figure 111.

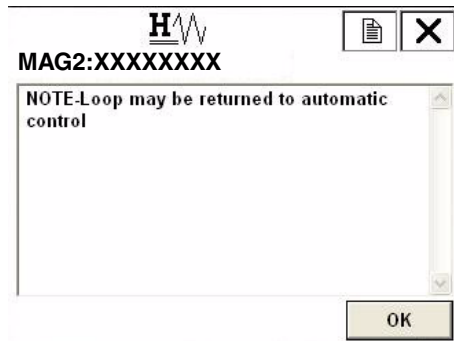

Figure 112.

6. Execute the same procedures for the other two manual zero adjustments.

Gain Adjustment

To adjust gain, proceed as follows.

1. From online menu,
 - Select:
 - 1. Device setup
 - 2. Diag/Service
 - 3. Calibration
 - 4. Gain trim
 Figure 113 is then displayed. If the control system is not affected by the forcible change of the current signal, press F4 (OK). By pressing F3 (ABORT), the procedure is canceled.



Figure 113.

2. Figure 114 then appears. Connect the calibrator, and then press F4 (OK).

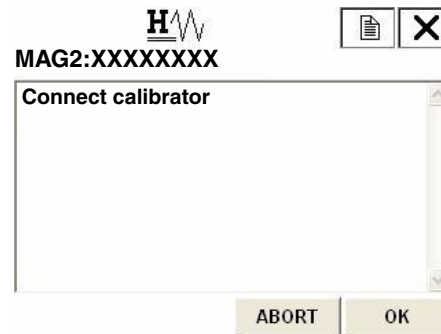

Figure 114.

3. Once the display as shown in Figure 115 appears, move the arrow key up or down to select a gain to adjust, and then press F4 (ENTER). This time, select 0 m/s.

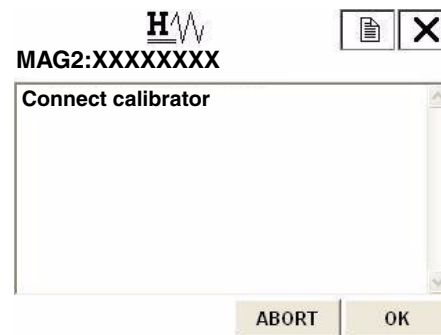

Figure 115.

4. Figure 116 then appears. Set the connected calibrator value to 0.0 m/s and then press F4 (OK).

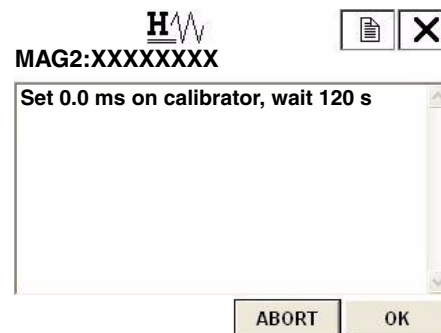

Figure 116.

5. Figure 117 then appears. When executing the adjustment, press F4 (ENTER) to start the adjustment.



Figure 117.

6. Figure 118 then appears. Please wait until the adjustment completes.

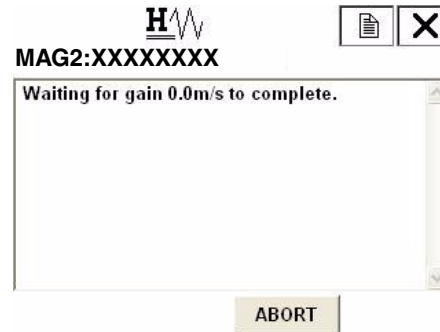

Figure 118.

7. After the gain adjustment has been completed, the display shown in Figure 119 appears. Gain adjustment of 0.0 m/s is now completed. For gain adjustment of 2.5 m/s and 10 m/s, follow the same procedures as shown above.



Figure 119.

Pulse Output Adjustment

To adjust the pulse output, proceed as follows.

1. From online menu, Select:
 1. Device setup
 - 2. Diag/Service
 - 3. Calibration
 - 5. Pulse trim
 Figure 120 is then displayed. If the control system is not affected by the forcible change of the current signal, press F4 (OK). By pressing F3 (ABORT), the procedure is canceled.



Figure 120.

- Figure 121 then appears. Connect the device to measure the pulse output, and then press F4 (OK).

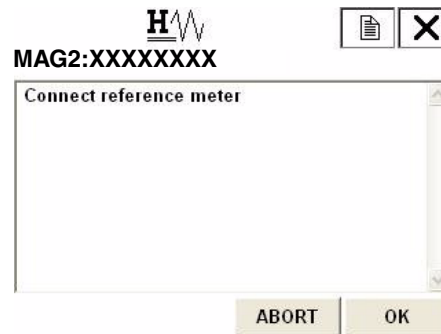

Figure 121.

- Figure 122 then appears. By pressing F4 (OK), the pulse output adjustment starts and the transmitter outputs a pulse of 90 Hz. If it is fine, press F4 (OK).



Figure 122.

- Figure 123 then appears. When executing the adjustment, select “Set”, and then press F4 (ENTER).



Figure 123.

- A numerical value input display (Figure 124) then appears. Measure the pulse frequency from the transmitter and enter the frequency by the Hz into the device. Once the input has been completed, press F4 (ENTER). The transmitter starts adjusting to 90 Hz automatically, and returns back to the display as shown in Figure 123. Verify that the pulse output is 90 Hz, and terminate the adjustment.

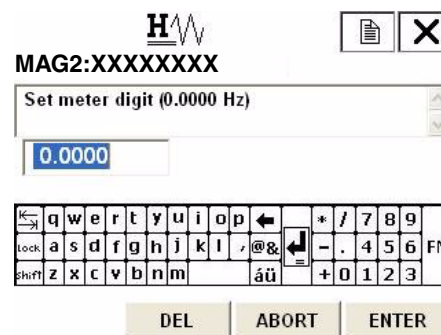

Figure 124.

Excitation Current Adjustment

To adjust the excitation current adjustment, proceed as follow.

1. From online menu, Select:

1. Device setup
- 2. Diag/Service
- 3. Calibration
- 6. Ex current trim

Figure 125 is then displayed.

If the control system is not affected by the forcible change of the current signal, press F4 (OK). By pressing F3 (ABORT), the procedure is canceled.

2. Once the display as shown in Figure 126 appears, move the arrow key up or down to select an excitation current to adjust, and then press F4 (ENTER). This time, select 3.5 mA.

3. Figure 127 then appears. Connect the device to measure excitation current to the both ends of the excitation check pin and press F4 (OK).

4. Figure 128 then appears. By pressing F4 (OK), excitation current adjustment starts, and the transmitter adjusts the excitation current to 3.5 mA. If it is fine, press F4 (OK).



Figure 125.

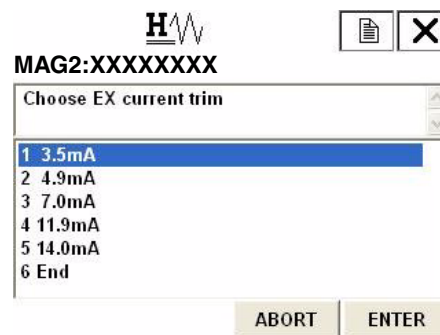

Figure 126.

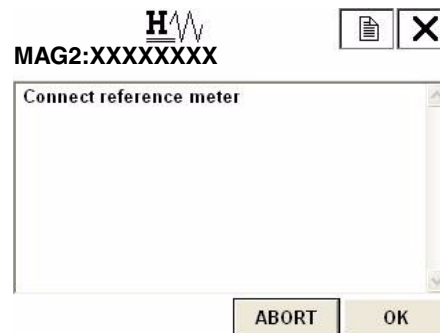

Figure 127.



Figure 128.

5. Figure 129 appears. When executing the adjustment, choose “Set” and press F4 (ENTER).

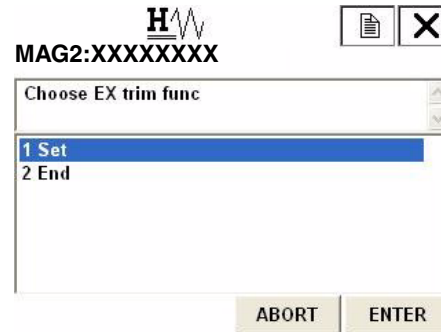

Figure 129.

6. A numerical value input display (Figure 130) then appears. Resistance of 10 ohm is in between the check pin. Therefore, when the excitation current is 3.5 mA, approx. 35 mV is output. Measure this value, and input the value by the mV directly. Press F4 (ENTER). The transmitter starts adjusting to 3.5 mA automatically, and returns back to the display as shown in Figure 129. Verify that the excitation current value is 3.5 mA, and terminate the adjustment.



Figure 130.

7. For the other excitation current adjustment, follow the same procedure as shown in above.

Output Check

Analog Output Check With a Calibrator

— **NOTE** —

For use by Invensys personnel only.

This function is used for the loop check using a calibrator. 0% or 25% to 100% of the setting range can be selected for the analog output check with the calibrator.

To output a fixed value of analog current by using a calibrator, proceed as follows:

1. 1. From online menu,
Select:
 1. Device setup
 2. Diag/Service
 2. Loop test
 1. Loop check mode
 Figure 131 is then displayed.

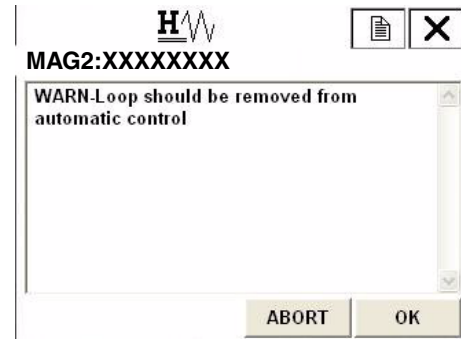

Figure 131.

2. Once the display as shown Figure 131 appears, make sure that the loop is removed from the automatic control. Then press “OK” to execute the output check with a calibrator. Then Figure 132 is displayed.

Move the arrow key up or down and select “1 Start” to execute the loop check.



Figure 132.

3. During the loop check, Figure 133 is displayed. If the loop check is finished, move the arrow key up or down and select “1 End” to select other analog output value for the loop check. If you finish the loop check, move the arrow key up or down and select “2 Abort” to abort. Then Figure 134 is displayed.

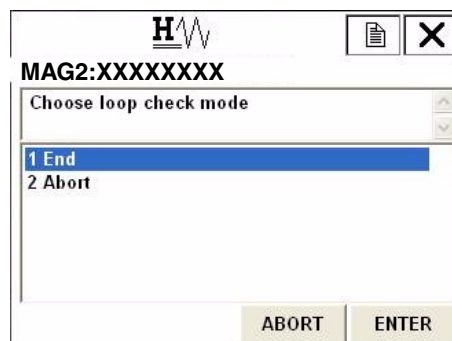

Figure 133.

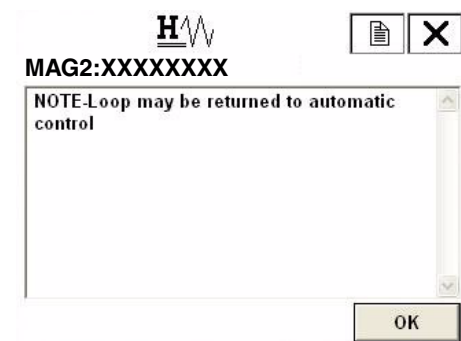

Figure 134.

4. Once the display as shown Figure 134 appears, press “OK” to abort. Then Figure 135 is displayed. Press “OK” and then the screen returns to the loop test menu as shown in Figure 136.



Figure 135.

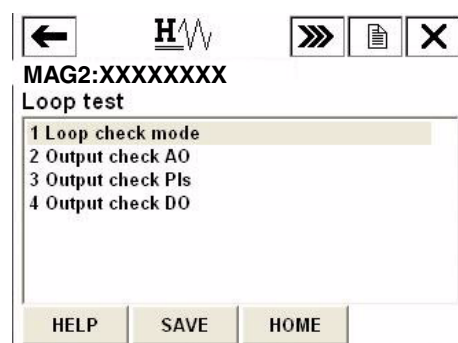

Figure 136.

Analog Output Check

To output fixed value of analog current, proceed as follows.

1. From online menu,
 - Select:
 - 1. Device setup
 - 2. Diag/Service
 - 2. Loop test
 - 1. Output check AO
 Figure 137 is then displayed. If the control system is not affected by the forcible change of the current signal, press F4 (OK). By pressing F3 (ABORT), the procedure is canceled.
2. Figure 138 then appears. Choose Start to start fixed value of analog current output, and then press F4 (ENTER).

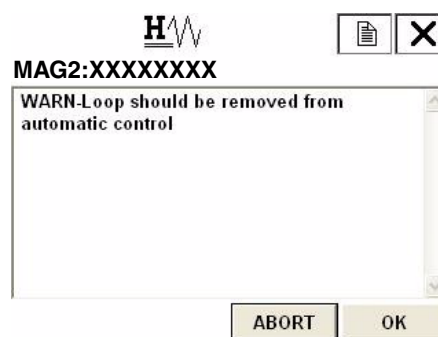

Figure 137.

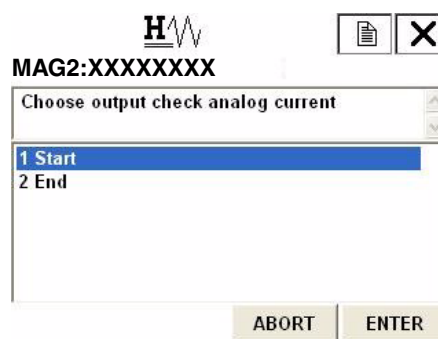

Figure 138.

3. A note of caution appears as shown in Figure 139. To proceed, press F4 (OK).

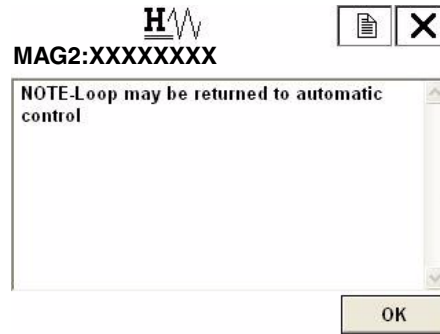

Figure 139.

4. Use the numeric keys to enter a fixed value to be output in the value input display. Setting range is duty ratio of 0% to +100%. When value is entered, press F4 (ENTER). Analog current corresponding to its output is output. Press F3 (ABORT) to return to the previous menu.

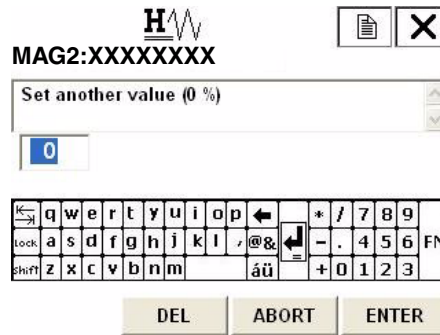

Figure 140.

Pulse Output Check

To output pulse fixed value, proceed as follow.

1. From online menu, Select:
 1. Device setup
 - 2. Diag/Service
 - 2. Loop test
 - 3. Out put check Pls
 Figure 141 is then displayed. If the control system is not affected by the forcible change of the current signal, press F4(OK). By pressing F3 (ABORT), the procedure is canceled.

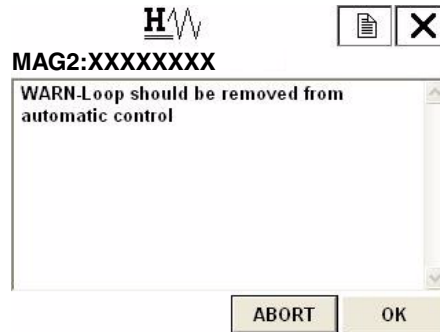

Figure 141.

- Figure 142 then appears. Choose Start to start fixed value of pulse output, and then press F4 (ENTER).

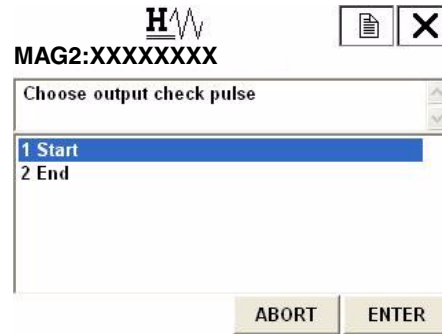

Figure 142.

- A note of caution appears as shown in Figure 143. To proceed, press F4 OK).

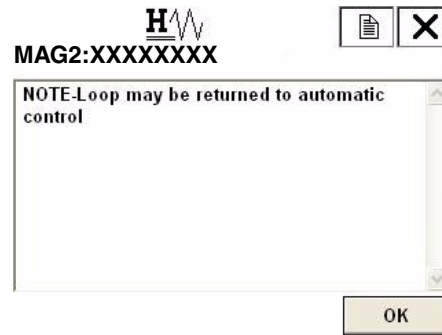

Figure 143.

- Use the numeric keys to enter a fixed value to be output in the value input display. Setting range is duty ratio of 0% to +100%. When value is entered, press F4 (ENTER). Pulse corresponding to its output is output. Press F3 (ABORT) to return to the previous menu.



Figure 144.

Contact Output Check

To output contact fixed value, proceed as follows.

1. From online menu,
 - Select:
 1. Device setup
 - 2. Diag/Service
 - 2. Loop test
 - 3. Out put check Do

Figure 145 is then displayed.
If the control system is not affected by the forcible change of the current signal, press F4 (OK). By pressing F3 (ABORT), the procedure is canceled.
2. Figure 146 then appears. Choose Start to start fixed value of contact output, and then press F4 (ENTER).
3. Figure 147 appears. Move the arrow key up or down to select an OPEN or CLOSE. After making a selection, press F4 (ENTER). Selected contact is output. Press F3 (ABORT) to return to the previous menu.

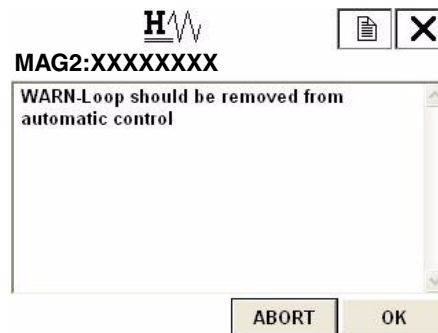

Figure 145.



Figure 146.

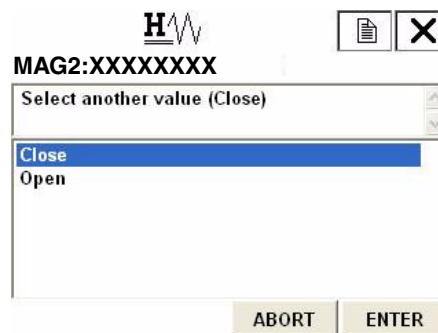

Figure 147.

Other Functions

Verifying Status of the Transmitter

To verify the status and setting of the device, proceed as follow.

1. From online menu, Select:
 1. Device setup
 - 2. Diag/Service
 - 1. Device Status
 Figure 148 is then displayed.



Figure 148.

2. There are 3 groups. Each group has different items to be verified. Figure 149 shows an example of “Status group 1”.

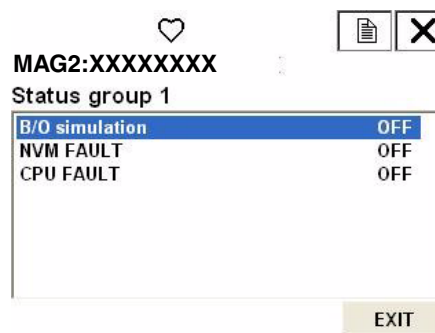

Figure 149.

3. Table 14 shows the items to be verified in each group.

Table 14. Items in Each Group

Group	Item	Description
Group 1	B/O SIMULATION	Burn Out Status
	NVM FAULT	Abnormal non-volatile memory
	CPU FAULT	Abnormal CPU
Group 2	IN LOCAL MODE OFF	Changing the setting from display
	DO OUTPUT MODE OFF	Checking the contact output
	PLS OUTPUT MODE OFF	Checking the pulse output
	AO OUTPUT MODE	Checking the analog output
	IN CALIB MODE	Adjusting
	NOT CALIBRATED	Non adjusted
	EX OUTPUT MODE	Checking the excitation current

Table 14. Items in Each Group

Group	Item	Description
Group 3	EMPTY OR SCALE ERROR	EMPTY or scale appears on electrode
	IN OUTPUT SCALE MODE w/CALIB	Checking the analog output using calibrator
	HI<LO ALM ERROR	Abnormal high/Low alarm setting
	SPAN OVER ERROR	Span gone beyond its high limit
	PLS SCALE ERROR	Pulse scale setting error
	PLS WIDTH ERROR	Pulse width setting error

Tag Setting

To set the tag, proceed as follow.

1. From online menu, Select:
 1. Device setup
 - 3. Basic setup
 - 1. Tag
 Figure 150 is then displayed.

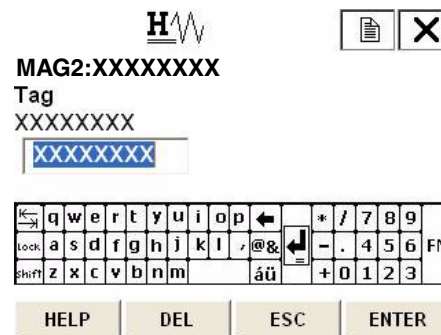

Figure 150.

2. Once the display as shown in Figure 150. appears, use the arrow key up, down, right or left and numerical keys to enter the number. After entering, press F4 (ENTER). If F3 (ESC) is pressed here, the selection is canceled and the display returns to the Basic setup menu.
3. After returning to the Basic setup menu, press F2 (SEND). Changed setting is sent to the transmitter.

Shipping Data Recovery

Follow the procedure described below to execute the shipping data recovery. Make sure that when it is executed, the internal data returns to the factory setting.

1. From online menu,
Select:
 1. Device setup
 - 2. Diag/Service
 - 3. Calibration
 - 6. Shipping RCVRFigure 151 is then displayed.

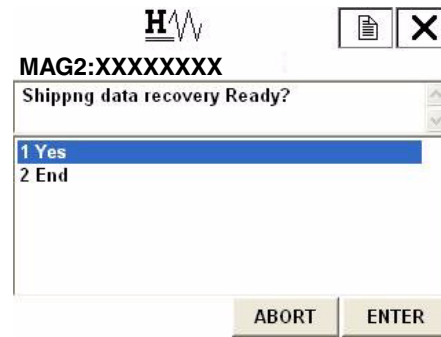

Figure 151.

2. When executing shipping data recovery, select **Yes** and press F4 (ENTER). Shipping data recovery executes, and the display returns to Figure 151. Press F3(ABORT) to return to the previous menu.

Review

From online menu, select:

1. Device setup → 5. Review

Then, the status of the device can be confirmed (see Figure 152). Use F2 (PREV) and F3 (NEXT) to move the confirming items.

Review	
1 Model	MAG2
2 Distributor	Foxboro
3 PV unit	m3/h
4 PV URV	m3/h
5 PV LRV	0.00 m3/h
6 PV USL	84.82 m3/h
7 PV LSL	0.00 m3/h
8 PV Min span	0.00000 m3/h
9 Xfer fnctn	Linear
Lo flo cutoff	2 %
Tube size	50 mm
Puls scaling	27.77637 cm3/P
Puls Width	30 ms
PV Damp	3.0 s
AO Alrm typ	Lo
Write protect	No
Manufacturer	Foxboro
Dev id	0
Tag	XXXXXXXX
Descriptor	XXXXXXXXXXXXXXXXXXXX
Message	XX
Universal rev	5
Fld dev rev	1
Software rev	5.0
Poll addr	0
Num req preams	5
Final asmbly num	0

Figure 152.

Short Cut Commands and Menus for HART Communicator

Short Cut Keys

Select the item to set from the table below, and press the item number from the online menu. You can move to the item, which you want to set quickly.

Basic setting	
Flow unit	132
Range	133
Specific gravity	134
Damping time constant	135

Totalized value setting	
Totalized value display	14231
Totalized restart value	14232
Totalized value reset	14233

Auto zero	136
Display selection	137
Function selection	138
Correction coefficient	139

Flowtube setting	
Flowtube diameter	1411
Flowtube type	1412
Flowtube constant	1413
Flowtube constant C2	1414

Signal processing	
Auto spike cut	1432
Moving average processing	1433
Moving average processing time	1434
Low flow cut	1435
Drop-out	1436
Electrode status sensitivity	1437
Electrode status output mode	1438

Pulse setting	
Pulse scale unit	14221
Pulse scale	14222
Pulse width	14223

Emergency setting	
High alarm value setting	14241
Low alarm value setting	14242
Contact output status setting	14243
Burnout (Analog output)	14215
Burnout (Pulse output)	14225

Device adjustment	
Analog current output adjustment	1231
Manual zero	1233
Gain adjustment	1234
Pulse output adjustment	1235
Excitation current adjustment	1236

Output inspection	
Analog output check w/calibrator	1221
Analog output check	1222
Pulse output check	1223
Contact output check	1224

Others	
Transmitter status	121
ID setting	131
Shipping data recovery	1236
Review	15

Menu Tree

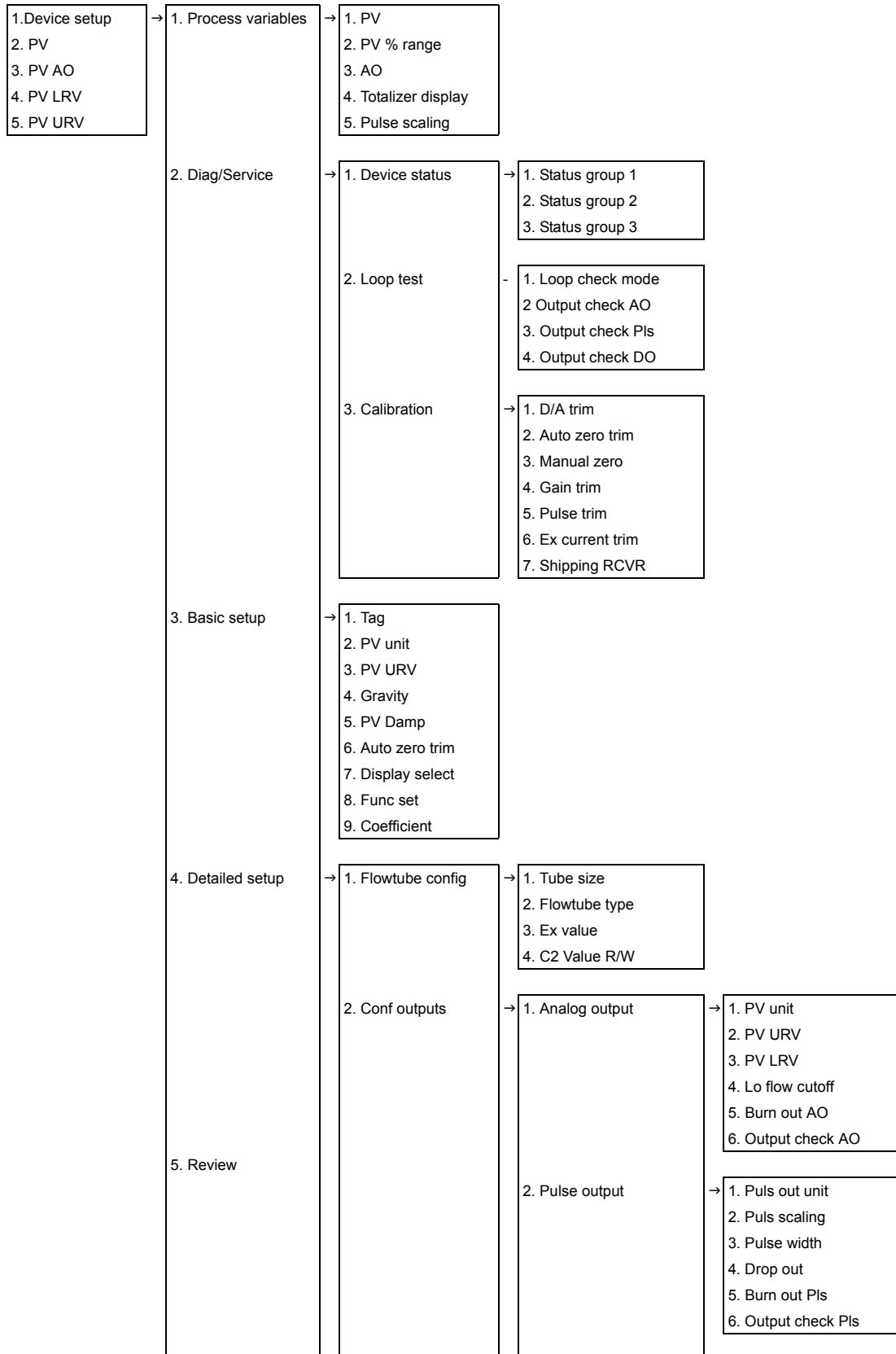

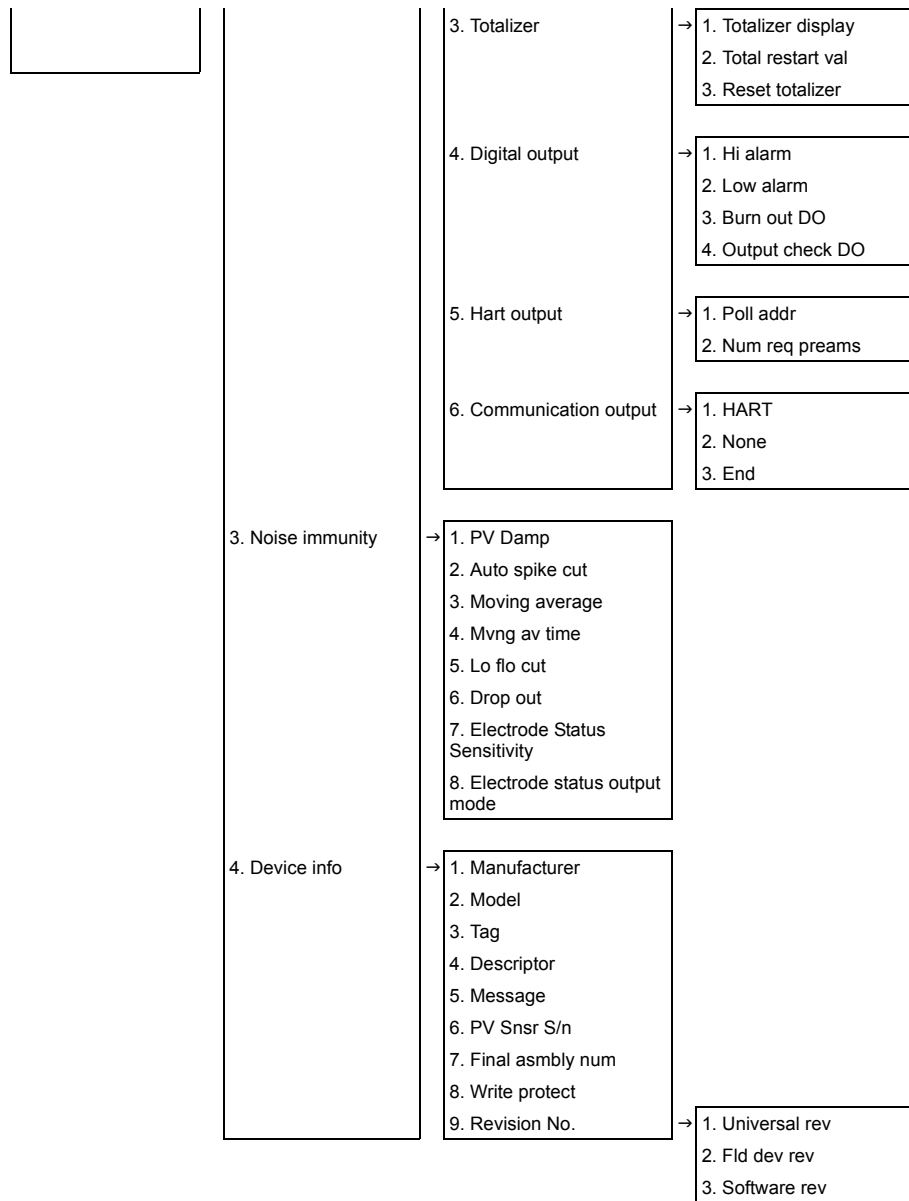

6. Maintenance and Troubleshooting

Maintenance

Replacement of Local Display

Step	Procedure
1	Power off the transmitter by circuit breaker etc.
2	The transmitter front cover is secured by hexagon socket head screws (M3). Loosen these screws with a 1.5 mm hex-head wrench.
3	Remove the transmitter front cover by turning it counterclockwise.
4	Remove the three screws securing the display.
5	Remove the display by pulling it out.
6	Align the new display connector to the transmitter connector.
7	Turn the local display unit to the desired direction and align it to the threaded holes in the transmitter housing. See Figure 9 for allowable turning range.
8	Secure the local display unit using the three screws removed in Step 4. When tightening the screws, use care not to entangle the cable connecting the local display unit to the transmitter. Note: The connector is connected firmly by tightening the screws.
9	Reattach the front cover.

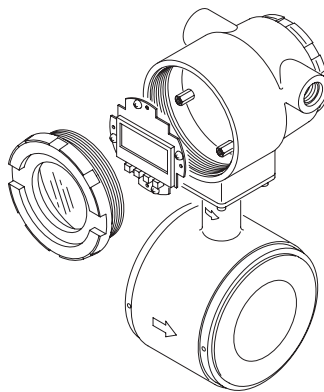

Figure 153. Local Display Replacement

— NOTE

When unpacking the flowtube, do not open the packing in a location with high temperature and humidity or in a dust or corrosive gas atmosphere.

Replacement of the Electronic Unit

This procedure is only for a flowmeter certified flameproof for ATEX Ex d mb ia IIC.

—  CAUTION

The following instructions must be followed carefully, when the housing of a MAG2IC flowmeter that is certified flameproof for ATEX Ex d mb ia IIC has to be opened and closed.

Overview

The MAG2IC flowmeter has fuses to secure the explosion proof capability.

If a fuse break occurs, the analog output remains in 0% of flow rate.

If the analog output remains in 0% flow rate, check whether the fuse break appears or not by following the procedures.

Before Opening

Make sure that there is no explosion hazard. If necessary, provide a "Gas-free certificate". Make sure that all connections must be voltage free.

How To Check For a Fuse Break

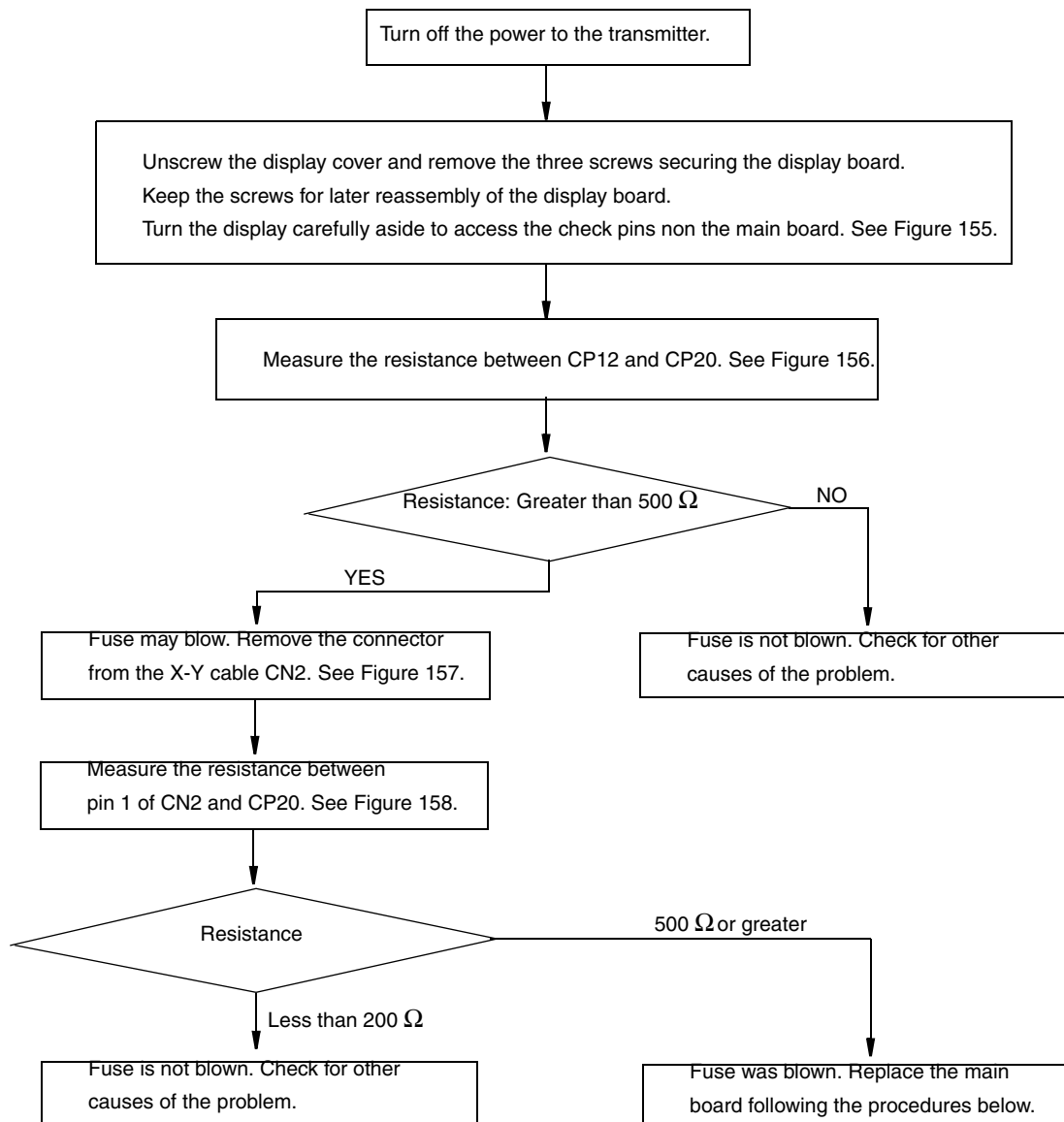

Figure 154. Checking for a Fuse Break

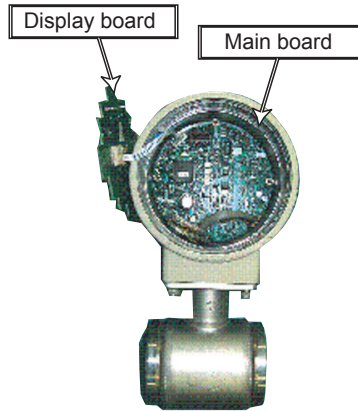

Figure 155. Accessing the Main Board

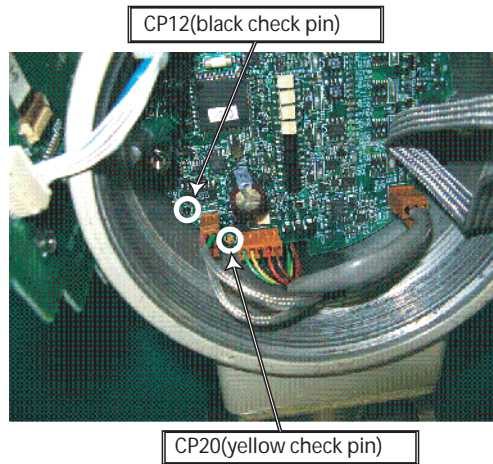

Figure 156. Checking the Resistance

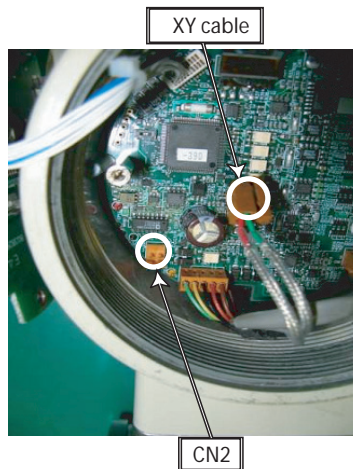

Figure 157. Removing X-Y Cable

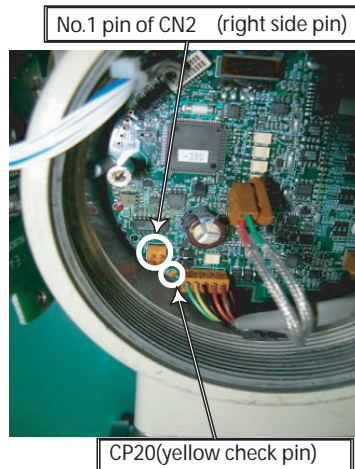

Figure 158. Measuring the Resistance

How to Replace the Main Board

Step	Procedure
1	Unscrew the three spacers which secure the main board. Save the spacers. See Figure 159.
2	Carefully disconnect the four connectors on the main board. See Figure 160.
3	Replace the main board with a new one.
4	Carefully connect the four connectors respectively to the replaced main board. See Figure 160.
5	Reassemble the replaced main board with the three spacers removed in Step 1. See Figure 159.
6	Mount the display board and tighten the three screws.
7	Before the cover is screwed back into the housing, the thread must be clean and well greased.
8	Screw the display cover as tight as possible into the housing to secure the required Ingress Protection (IP) degree.
9	Tighten the hexagon socket head cap screw of the interlocking device.

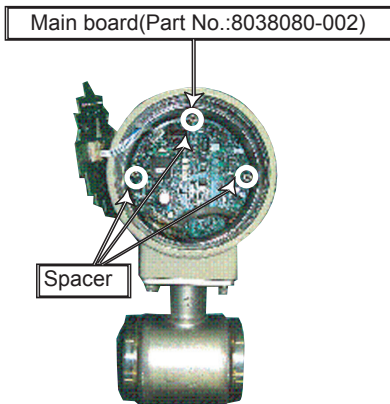

Figure 159. Spacer Locations

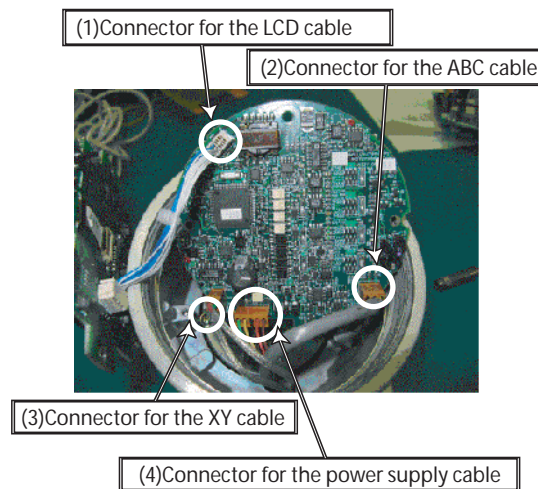

Figure 160. Connector Locations

Troubleshooting

Types of Troubles

If a problem occurs at the instrument start-up and operation, the following three causes should be considered.

- ◆ Inconsistency between the specifications and actual operating conditions.
- ◆ Mis-setting or mis-operation.
- ◆ Instrument malfunction.

If a problem occurs during operation, the device's self-diagnostic function will classify it as critical or noncritical. It will indicate this and respond accordingly.

Critical Failure

Critical problems may obstruct electromagnetic flowmeter operation, and if not corrected, ultimately damage the flowmeter. When a critical problem occurs during operation, an error message will appear on the transmitter display panel and the output continues to output the value set in the direction of abnormality processing. The error message and self-diagnosis results can be read via a HART Communicator or PC-Based Configurator.

Noncritical Failure

Noncritical problems will not seriously affect electromagnetic flowmeter operation. When an error occurs during operation and is regarded as a non-critical problem by the transmitter self-diagnostics, the output does not burn-out and the flowmeter continues to output the measured value.

Troubles at Startup

When a problem occurs at start-up, perform the following procedures. If the problem remains, it is possible that the device has been damaged. Contact Invensys.

Trouble	Check Point and Troubleshooting
No indication on display panel when powered on.	<ul style="list-style-type: none"> • Check the specifications of the power source. • Check the wiring. • Check that the ambient temperature is not under -4°F (-20°C).
No output when powered on.	<ul style="list-style-type: none"> • Check the signal line for correct connection.
Communication failure.	<ul style="list-style-type: none"> • Check the signal line for correct connection. A load resistance of 250 Ω or more is required when using a HART Communicator or PC-Based Configurator. • Check the communicator for correct connection. • Is model MAG2 DD (device description) downloaded on the HART Communicator?
No pulse output	<ul style="list-style-type: none"> • Check the counter type, input specifications and contact capacity. • Check the pulse setting of the flowmeter.

Troubles During Operation

When a problem occurs during operation, perform the following procedures.

1. Search for the symptom of the trouble in the table on this page. If found, perform the steps indicated in the table.
2. If communication is possible, read the error message and self-diagnosis results. Perform referring to “Error messages and troubleshooting”.

3. If the problem can not be solved, it is possible that the device has been damaged. Contact Invensys.

Trouble	Check Point and Troubleshooting
Output fluctuates excessively beyond the estimated flow rate range	<ul style="list-style-type: none"> • Check if the instrument is grounded correctly. • Check if the damping time constant is set correctly. • Clean the electrodes. • The analog output may fluctuate due to flow noise, which is generated by the process fluid flow. In such a case, connect the upstream grounding ring to the downstream grounding ring by a wire. The output fluctuation may be reduced. • A circuit in some PLC may affect the flow measurement and the analog output may fluctuate. In this case, make sure that the both PLC and the MAG2 flowmeter are properly grounded. Proper grounding solves the fluctuation problem.
Output exceeds 100%.	<ul style="list-style-type: none"> • Check if the range is set correctly. • Check if zero is adjusted correctly.
Output remains 0%	<ul style="list-style-type: none"> • Check if the signal line is connected correctly. • Check the upstream and downstream valves. • Check if the range is set correctly. • Check that Output Check mode is off. • Check if the flow rate is not within the set range of low-flow cutoff. • Check if the flow rate is not reversed (negative flow rate). • Check the flowtube for unfilled condition, too low conductivity, excessive noise, etc.
Output is not working	<ul style="list-style-type: none"> • Refer to “Description of Error Messages” on page 119.
Pulse output is too large or too small	<ul style="list-style-type: none"> • Is the pulse setting (weight and width) correct? • Is the mA output from the main unit correct? • Is the dropout value correctly set between 0 and 10%.

Index

C

- Cable Length Between Remote Transmitter and Flowtube 18
- Calibration Mode Configuration 111
- Configuration
 - Engineering Mode 85
 - Maintenance Mode 104
 - Calibration Mode 111
 - Critical Mode 116
 - Output Check Mode 105
 - Operator's Mode 60
- Critical Mode Configuration 116

E

- Engineering Mode Configuration 85
- Error Messages 119

H

- HART Communicator Operation 121

I

- Installation 11
 - Flange Type Flowtube 29
 - Location 11
 - Remote-Type Transmitter 38
 - Wafer Type Flowtube 18

L

- Local Display Operation 51
- Local Display, Changing Direction of 17

M

- Maintenance 165
- Maintenance Mode Configuration 104
- Measuring Mode Description 57

O

- Operation Via HART Communicator 121
- Operation Via Local Display 51
- Output Check Mode Configuration 105

R

Reference Documents 1

S

Shutdown 49

Specifications

Product Safety 9

Standard 1

Start-Up 49

T

Transmitter, Changing Direction of the 14

Troubleshooting 170

W

Wiring 39

Write Protection 54

ISSUE DATES

DEC 2008

FEB 2010

APR 2010

Vertical lines to the right of text or illustrations indicate areas changed at last issue date.

Invensys Operations Management
5601 Granite Parkway Suite 1000
Plano, TX 75024
United States of America
www.iom.invensys.com

Invensys Global Client Support
Inside U.S.: 1-866-746-6477
Outside U.S.: 1-508-549-2424 or contact
your local Invensys representative.
Email: support@invensys.com
Website: <http://support.ips.invensys.com>

Invensys and Foxboro are trademarks of Invensys plc, its
subsidiaries, and affiliates.
All other brand names may be trademarks of their
respective owners.

Copyright 2008-2010 Invensys Systems, Inc.
All rights reserved