

**I/A Series<sup>®</sup> Electronic Pressure Transmitters  
Options and Accessories**



*The Foxboro<sup>®</sup> brand I/A Series<sup>®</sup> Pressure Transmitters are offered with a wide variety of features, options, accessories, and services that add to the performance and capabilities of this versatile family of digital and analog output pressure transmitters.*

**FEATURES/ACCESSORIES/SERVICES**

- ▶ Intelligent digital output transmitters with FoxCom<sup>™</sup>, HART, FOUNDATION fieldbus, or Modbus communication protocols.
- ▶ Electronic transmitters with 4 to 20 mA or low power, low voltage 1 to 5 V dc analog outputs.
- ▶ Absolute, gauge, d/p Cell<sup>®</sup>, multirange, multivariable, and premium performance transmitters.
- ▶ d/p Cell transmitters with traditional or low profile/Coplanar<sup>™</sup> structures.
- ▶ Transmitters with direct connect or capillary connected seals; or with integral end connections for sanitary, pulp and paper, and high gauge pressure applications.
- ▶ SIL2 Transmitters for certain HART versions.
- ▶ PC-based configurators and communicators for remote communication.
- ▶ Integral or optional LCD indicator with pushbuttons for local configuration.
- ▶ Electrical conduit adapters.
- ▶ One, two-, three-, and five-valve manifolds.
- ▶ Process venting and bleeding options.
- ▶ Special degreasing and cleaning.
- ▶ Bracket sets for pipe mounting.
- ▶ NACE MR 01-75 compliance.
- ▶ Special stainless steel and NACE bolting.
- ▶ Low temperature and high pressure options.
- ▶ Custom configuration.

- ▶ External zero adjustment.
- ▶ Quality assurance certificates.
- ▶ Compact orifices and orifice plates; also integral flow orifices for very low flow rates.
- ▶ Custody transfer cover locks and seals.
- ▶ Primary devices (nozzles, Venturis, etc.).
- ▶ DP regulators, power supplies, rotameters for control of purge rate, and pressure snubbers.
- ▶ Supplemental customer tag.
- ▶ Accessories conforming to European Union Directives are marked with “CE” logo.
- ▶ Custom options to user's requirements
- ▶ Optional “getting started” instructions.
- ▶ Standard 5-year warranty; 17 year optional with Multirange and Premium Performance transmitters.
- ▶ See inside pages for more accessories/services.

### GENERAL INFORMATION

#### I/A Series Pressure Transmitters

- ▶ Differential Pressure (DP)
- ▶ Gauge Pressure (GP)
- ▶ Absolute Pressure (AP)
- ▶ S Series Absolute, Gauge, and Differential Pressure
- ▶ Multivariable Transmitter versions offered for AP, DP, T, Density, Mass Flow Rate, and Tank Level Measurements
- ▶ Multirange GP and DP Transmitters
- ▶ Premium Performance Multirange GP and DP Transmitters
- ▶ Transmitters with Pressure Seals:
  - Flanged Level - Direct Mount
  - Flanged - Remote or Direct Mount
  - Threaded - Remote or Direct Mount
  - In-Line Saddle Weld - Remote or Direct Mount
  - Sanitary - Remote Mount
  - Sanitary Level - Direct Mount
- ▶ Transmitters with Integral Connectors
  - For sanitary processes
  - For pulp and paper processes
  - For high gauge pressure applications
- ▶ Transmitters with 1-, 2-, 3-, and 5-Valve Manifolds:
  - For general purpose applications
  - For natural gas applications
  - For power industry applications
- ▶ Transmitters for SIL2 Applications:
  - HART Versions only (-T version)
  - IAP10, IGP10, IAP20, IGP20, and IDP10 transmitters only.

#### Transmitter Electronic Versions

Electronic Version	Transmitter with:
-D	FoxCom Communication Protocol
-T	HART Communication Protocol
-F	FOUNDATION Fieldbus Protocol
-M	Modbus Communication Protocol
-A	Analog 4 to 20 mA dc Output
-V	Analog 1 to 5 V dc Output

Throughout this document, rather than spell out the electronic version, the version may be specified as Version -D or Electronic Version -D, rather than FoxCom Communication Protocol.

#### Custom Options

Many times a particular instrument or option with simple or complex modifications will greatly enhance the versatility of an I/A Series Pressure Transmitter. If you need a custom option not listed in this document, please contact Invensys.

#### Transmitter Structures

Many d/p Cell style transmitters are offered with Traditional or Low Profile (LP1 or LP2) structures as indicated in the table and figures that follow.

Transmitter Model	Available with Structure		
	Traditional	LP1	LP2
IAP20	Yes	No	No
IGP20	Yes	No	No
IDP10/IDP10S	Yes	Yes	Yes
IDP25	Yes	Yes	Yes
IDP50	Yes	Yes	Yes
IMV25	Yes	Yes	Yes
IMV30	Yes	No	No
IMV31	Yes	No	No

**TRADITIONAL STRUCTURE**

The traditional structure is the commonly used right angle design, where the process connections are oriented 90 degrees from the transmitter centerline. This traditional transmitter structure allows easy retrofitting of any transmitter of similar design.

Figure 1. Traditional Structure

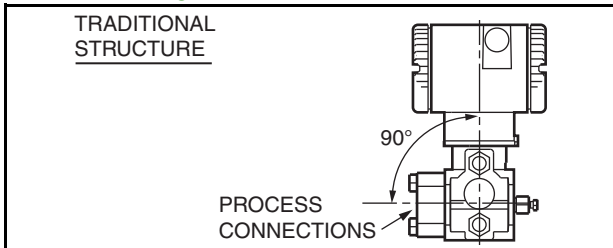

**LOW PROFILE STRUCTURES**

The low profile structure has an inline design that places the transmitter process connections in line with the transmitter centerline. This transmitter configuration provides a style similar to competitive Coplanar transmitters. The low profile transmitter is offered in either an LP1 or LP2 configuration.

Figure 2. Low Profile LP1 Structure

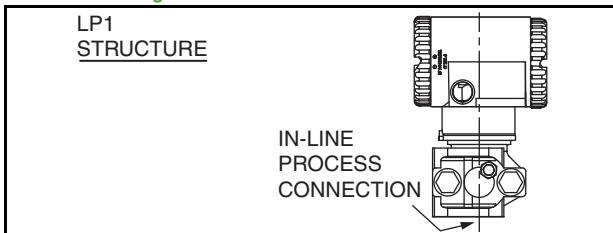
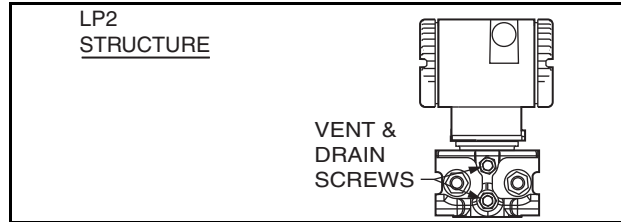

Figure 3. Low Profile LP2 Structure



**Ordering Instructions**

Options with Model Code Suffix, such as LCD Indicator (-L1) or Stainless Steel Mounting Bracket (-M2) are specified by adding the Model Code Option Suffix to the end of the transmitter Model Number. For example, for basic transmitter IDP10-D20B2NF, add suffixes -L1M2 (or -M2L1) to make a complete Model Number of IDP10-D20B2NF-L1M2 for a transmitter with an LCD Indicator and a stainless steel Mounting Bracket.

Options/Accessories having an Auxiliary Specification (AS) Code, or a Foxboro® Part Number; many options/accessories have an "AS" Code or a Foxboro® Part Number. For example, a Plug-in Shorting Bar has an SB-11 "AS" Code, and a Calibration Screw has an F0101ES Foxboro Part Number. Therefore, in addition to specifying the transmitter model number (with optional suffixes), also specify the "AS" Code and Part Numbered items required.

Transmitters with Integral Flow Orifices or Compact Orifices; these orifice assemblies are supplied attached to the manifold/transmitter and shipped as an integral unit. Both the Transmitter and Orifice Model Numbers must be specified. Refer to the Orifice PSS to identify the Orifice Configuration and Model desired.

Transmitters Ordered with Separate Model Coded Items such as Pressure Seals or Manifolds; separately specify both the transmitter Model Number and the seal or manifold Model Number. Refer to the product PSS for further details.

**Summary Selection Tables**

Refer to Tables 13 through 17 at the end of this document for a summary of the options and accessories described in this document, and their availability (and applicability) for use with the numerous offerings in the I/A Series Pressure Transmitter Family. Within each table, “YES” means

that the option or accessory is offered, “NO” means that the option or accessory is not offered or not applicable to the particular transmitter listed.

**Index of Options and Accessories**

An index of options and accessories is included, for your convenience, at the end of this document.

**PRODUCT SPECIFICATION SHEETS (PSS) FOR TRANSMITTERS AND CONFIGURATORS**

**Table 1. I/A Series Intelligent Digital Output Transmitters and Configurators**

Transmitter and Configurator Type (a)	Transmitter/Configurator Specification Sheet			
	Version -D FoxCom	Version -T HART	Version -F Fieldbus	Version -M Modbus
IAP10/IAP20 AP Transmitters	PSS 2A-1C13 A	PSS 2A-1C13 B	PSS 2A-1C13 E	Not Applicable
IAP10S AP Transmitters	Not Applicable	PSS 2A-1C13 P	Not Applicable	Not Applicable
IGP10/IGP20 GP Transmitters	PSS 2A-1C13 A	PSS 2A-1C13 B	PSS 2A-1C13 E	Not Applicable
IGP10S GP Transmitters	Not Applicable	PSS 2A-1C13 P	Not Applicable	Not Applicable
IAP10/IGP10 Sanitary Industry	PSS 2A-1C13 K	PSS 2A-1C13 K	PSS 2A-1C13 K	Not Applicable
IAP10/IGP10 Pulp/Paper Industry	PSS 2A-1C13 L	PSS 2A-1C13 L	PSS 2A-1C13 L	Not Applicable
IGP10 High GP Transmitter	PSS 2A-1C13 F	PSS 2A-1C13 F	PSS 2A-1C13 F	Not Applicable
IGP25 MR GP Transmitter	PSS 2A-1C13 G	PSS 2A-1C13 G	PSS 2A-1C13 G	Not Applicable
IGP25 Sanitary Industry	PSS 2A-1C13 M	PSS 2A-1C13 M	PSS 2A-1C13 M	Not Applicable
IGP25 Pulp/Paper Industry	PSS 2A-1C13 N	PSS 2A-1C13 N	PSS 2A-1C13 N	Not Applicable
IGP50 PP GP Transmitter	PSS 2A-1C13 H	PSS 2A-1C13 H	PSS 2A-1C13 H	Not Applicable
IDP10 DP Transmitter	PSS 2A-1C14 A	PSS 2A-1C14 B	PSS 2A-1C13 E	Not Applicable
IDP10S DP Transmitter	Not Applicable	PSS 2A-1C14 M	Not Applicable	Not Applicable
IDP25 MR DP Transmitter	PSS 2A-1C14 K	PSS 2A-1C14 K	PSS 2A-1C14 K	Not Applicable
IDP50 PP DP Transmitter	PSS 2A-1C14 L	PSS 2A-1C14 L	PSS 2A-1C14 L	Not Applicable
IMV25 MV Transmitter (b)	PSS 2A-1C15 B	PSS 2A-1C15 B	PSS 2A-1C15 B	PSS 2A-1C15 D
IMV30 MV Transmitter (c)	PSS 2A-1C15 A	PSS 2A-1C15 A	Not Applicable	Not Applicable
IMV31 MV Transmitter (d)	Not Applicable	PSS 2A-1C15 C	Not Applicable	Not Applicable
PC20 Field Device Configurator	PSS 2A-1Z3 E	PSS 2A-1Z3 E	Not Applicable	Not Applicable
PCMV MV Configurator	PSS 2A-1Z3 F	PSS 2A-1Z3 F	Not Applicable	Not Applicable
PCMM MV Configurator	Not Applicable	Not Applicable	Not Applicable	PSS 2A-1Z3 H
PC50 Field Device Tool	PSS 2A-1Z3 G	PSS 2A-1Z3 G	Not Applicable	Not Applicable
HHT50 Field Device Configurator	PSS 2A-1Z3 L	PSS 2A-1Z3 L	Not Applicable	Not Applicable
HART/FF Communicator (e)	Not Applicable	Note (e)	Note (e)	Not Applicable

- a. AP = Absolute Pressure; GP = Gauge Pressure; DP = Differential Pressure; MR = Multirange; MV = Multivariable; PP = Premium Performance.
- b. IMV25 is used with Model PCMV and Model PCMM Configurator for flow measurements.
- c. IMV30 is used with Model PCMV Configurator for flow measurements.
- d. IMV31 is used with Model PC50 and HHT50 Configurator for level measurements.
- e. The HART/FF Communicator is for use with HART and Fieldbus Communication protocols. Contact Invensys for further details.



Table 2. I/A Series Electronic Analog Output Transmitters

Transmitter Type	Transmitter Specification Sheet	
	Electronic Version -A 4 to 20 mA dc Analog Output (Note (a))	Electronic Version -V 1 to 5 V dc Analog Output (Note (b))
IAP10/IAP20 Absolute Pressure Transmitters	PSS 2A-1C13 C	PSS 2A-1C13 D
IGP10/IGP20 Gauge Pressure Transmitters	PSS 2A-1C13 C	PSS 2A-1C13 D
IAP10/IGP10 with Integral Sanitary Connectors	PSS 2A-1C13 K	PSS 2A-1C13 K
IAP10/IGP10 with Integral Pulp & Paper Connectors	PSS 2A-1C13 L	PSS 2A-1C13 L
IGP10 High Gauge Pressure Transmitter	PSS 2A-1C13 F	PSS 2A-1C13 F
IDP10 d/p Cell Transmitter	PSS 2A-1C14 C	PSS 2A-1C13 D

- a. The -A Transmitter includes an explosionproof rating, but does not include an Intrinsically Safe rating. For I.S. rated 4 to 20 mA outputs, refer to Version -T transmitters.
- b. A low power, low voltage transmitter; 9 V dc minimum voltage, 3 mA maximum current.

INTELLIGENT TRANSMITTER CONFIGURATORS

**HART Communicator**

The HART battery-powered communicator is the common interface with microprocessor-based devices using the HART protocol. It can be provided either for HART protocol only, or for both HART and FOUNDATION Fieldbus protocols in a single unit. It is an intrinsically safe hand-held configurator that uses the Windows CE operating system. It is loaded with DDs that have been successfully tested. You can install new DDs, using the Easy Upgrade feature. It is provided with a stylus, straps, lead set with connectors, resource CD, carrying case, and instructions. This is a resale product and all documentation is what is available from the supplier. Contact Invensys for further details.

**Model PCMV Configurator**

This Configurator is a Windows-based software package for use with IMV25, IMV30, and IMV31 Multivariable Transmitters. It displays measurements and has full calibration and configuration capability. It also utilizes a fluid properties table to calculate flow rate and process density with the IMV30, and tank level, density, and pressure with the IMV31, and also primary device parameters. A modem is required for use with either HART or FoxCom communication. See the following table and PSS 2A-1Z3 F.

Measurement	Designation	With IMV25 (a)	With IMV30	With IMV31
mA Output	M0	Yes	Yes	Yes
Differential Pressure	M1	Yes	Yes	Yes
Absolute Pressure	M2 (b)	Yes	Yes	Yes
Sensor Temperature	M3	Yes	Yes	Yes
Electronics Temp.	M4	Yes	Yes	Yes
Process Temperature (External RTD)	M5	Yes	Yes	Yes
Flow Rate (Calculated)	M6	No	Yes	No
Process Density (Calculated)	M7	No	Yes	Yes
Liquid Level (Calculated)	M6	No	No	Yes
Height from Pressure Tap to Zero Level Point (Configurable)	H1	No	No	Yes
Height from Transmitter Connection to Pressure Tap (Configurable)	H2	No	No	Yes
Leg Height from Transmitter Connection to Tap Pressure Connection (Configurable)	H3	No	No	Yes

- a. The Model PCMV Configurator is used with the -D, -T, and -F versions of the IMV25; and the Model PCMM Configurator is used with the -M version of the IMV25.
- b. M2 is tank pressure with the IMV31.

### Model PCMM Configurator

This Configurator is a Windows-based software package for use with a Model IMV25 Multivariable Transmitter using Modbus communication protocol. An RS-232 to RS-485 converter or a USB Port to RS-485 converter is required for communication with the transmitter. The measured and transmitted outputs are absolute pressure (configurable for gauge pressure), differential pressure, process temperature (from an external RTD), sensor temperature (from an internal sensor), and electronics temperature (from an internal sensor). Refer to PSS 2A-1Z3 H for further details.

### Model PC20 Field Device Configurator

This Windows-based software and hardware package with external modem provides remote bidirectional communications with intelligent field devices having FoxCom or HART communication protocol. The software also supports the Common Practice and Universal HART commands for non-Foxboro HART devices. See figure below and PSS 2A-1Z3 E for specifications and ordering instructions. This device configurator only supports legacy products. See PSS for the listing of products that are supported.

Figure 4. Model PC20 Field Device Configurator

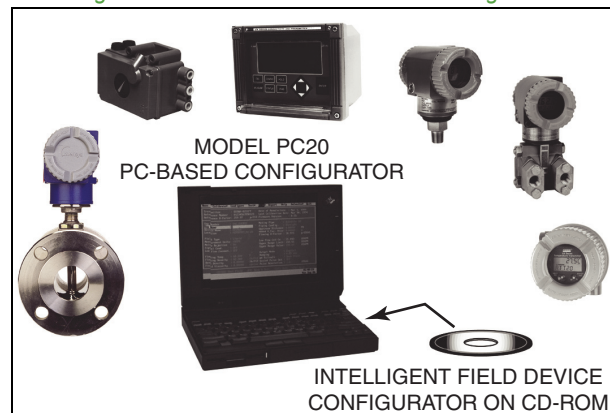

**Model HHT50 Configurator**

This is a powerful configuration tool for intelligent field devices having FoxCom or HART communication protocol. It is an open tool for integration with third party DTMs and conforms to FDT Specifications 1.2.1 and 2.0, which provides a standard mechanism for communication between applications and devices. It is a rugged unit that utilizes a Windows Tablet PC operating system, complete with Foxboro Model PC50 and PCMV configuration software fully loaded. It is provided with a carrying case, and numerous options (see adjacent figure). See PSS 2A-1Z3 L for specifications and ordering instructions.

*Figure 5. Model HHT50 Configurator*

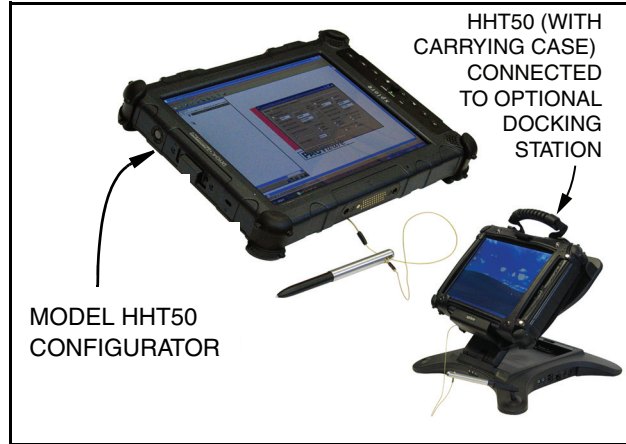

**Model PC50 Field Device Tool**

The Model PC50, a powerful Windows-based software and hardware package with external modem(s), provides for an intelligent field device life cycle management. It is also designed for open interface and provides bidirectional communication with devices from multiple vendors having FoxCom or HART communication protocol. Refer to PSS 2A-1Z3 G for specifications and ordering instructions.

*Figure 6. Model PC50 Field Device Tool*

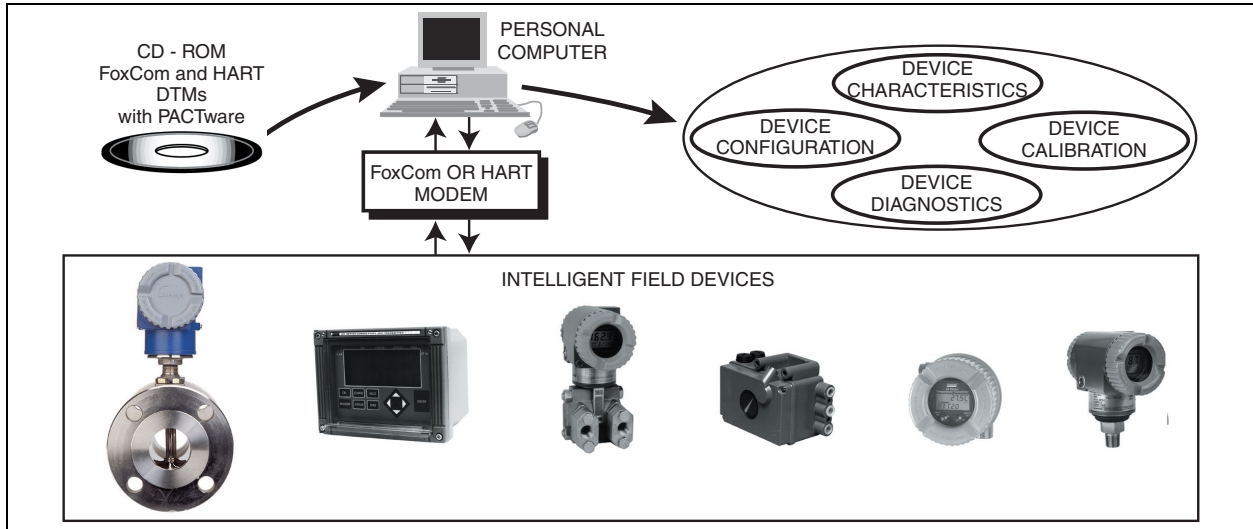

### INDICATOR OPTIONS

A wide choice of indicating meters gives the user an easily viewed “window” into the process. These indicators are available integrally mounted to the transmitter, or for remote mounting.

#### Options -L1/-L2: Integral LCD Indicator with Pushbuttons

(Standard with Electronic Versions -A and -V)  
(Optional with Electronic Versions -D, -F, and -T)

Indicator is integrally mounted to electronics housing (transmitter topworks). “CE” Logo marked on product indicates conformance to applicable European Union Directives.

Indicator Provides:

- ▶ Top Line Display for Measurement Readout
  - For Versions -D, -F, and -T: 5 numeric characters (4 if minus sign is used)
  - For Versions -A and -V: 4 numeric characters
- ▶ Bottom Line Display for Measurement Units
  - Seven alphanumeric characters available
- ▶ Configuration and Calibration prompts.

Pushbuttons (two) typically provide the following Configuration and Calibration Functions, depending on the electronics used:

- ▶ Linear and Square Root Output (as Applicable)
- ▶ Forward or Reverse Output
- ▶ Damping Adjustment
- ▶ Failsafe Action (High or Low (with 4 to 20 mA Output Transmitters only))
- ▶ Units Label on Bottom Line of Display
- ▶ Settable LRVs and URVs for Transmission and Display (on Top Line)
- ▶ Date of Last Calibration
- ▶ Number of days the transmitter has been powered up since the last user-defined event (S Series transmitters only)
- ▶ Total number of days the transmitter has been powered up over its lifetime (S Series transmitters only)
- ▶ Zero and Span settings, non-interactive to automatically set output to either 4 mA or 20 mA using the “NEXT” and “ENTER” pushbuttons (with 4 to 20 mA Output Transmitters only)

- ▶ 4 and 20 mA Jog Settings, allowing the user to easily increment the mA output signal up or down in fine steps to match a value shown on an external calibrator (with 4 to 20 mA Output Transmitters only)
- ▶ Reranging to set new calibrated ranges without applying pressure
- ▶ Secondary Digital Measurement
- ▶ Pushbutton Password Protection
  - to lock out configuration
  - to lock out calibration and configuration
- ▶ Enable/Disable Optional External Zero
- ▶ Tag (with Digital Output Transmitters only)

Model Code Suffix	Description
-L1	LCD Indicator with Window Cover (-D, -F, and -T Versions Only)
-L2	Blind Solid Cover over Standard LCD Indicator – Replaces Window Cover (-A and -V Versions Only)

Figure 7. Topworks with Cover Removed



**ELECTRICAL CONDUIT THREAD ADAPTERS**

The electronics housing may have two PG 13.5 (available on select transmitter models), 1/2 NPT, or M20 conduit connections for field wiring, depending on the transmitter type. The following optional adapters are for use with the conduit connections. Adapters are not offered with housings having M20 conduit connection threads. Unused conduit openings must be closed with a metal plug.

**Option -A1: Hawke-Type 1/2 NPT Brass Cable Gland**

Used with a 1/2 NPT Conduit Connection. Hawke-type cable gland with 1/2 NPT external thread. Used with Electrical Safety Codes in Table 3. See Figure 8.

Model Code Suffix	Description
-A1	Hawke-Type 1/2 NPT Cable Gland

Figure 8. Option -A1

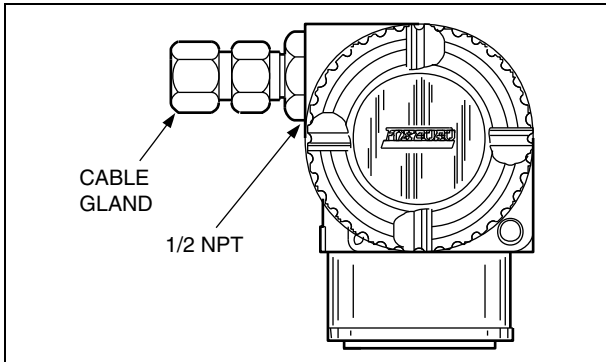

**Option -A2: PG 13.5 Plastic Cable Gland**

Used with a PG 13.5 conduit connection, available on selected models. A nylon cable gland for cable diameters from 9 to 14 mm used with Electrical Safety Codes in Table 3. See Figure 9.

Model Code Suffix	Description
-A2	Plastic PG 13.5 Cable Gland

Figure 9. Option -A2

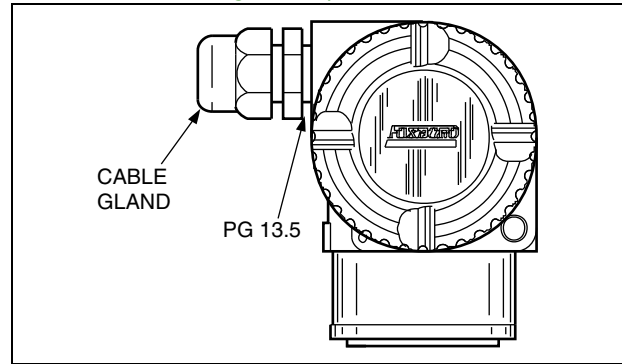

**Option -A3: M20 Stainless Steel Conduit Threaded Adapter**

Used with a 1/2 NPT Conduit Connection, and has an M20 x 1.5 - 6H internal thread. Used with Electrical Safety Codes in Table 3. See Figure 10.

Model Code Suffix	Description
-A3	M20 Threaded Adapter, 303 ss

Figure 10. Option -A3

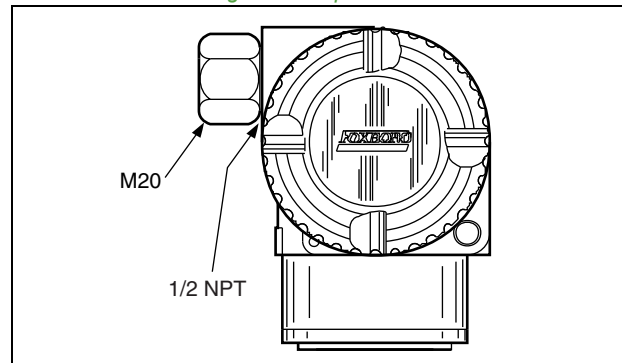



**Option -A4: PG 13.5 Nickel-Plated Brass Cable Gland**

Used with PG 13.5 conduit connection, available on selected models. Trumpet shape entry provides a smooth, strain-relieved support for cable diameters from 9 to 14 mm. Used with Electrical Safety Codes in Table 3. See Figure 11.

Model Code Suffix	Description
-A4	Brass PG 13.5 Cable Gland

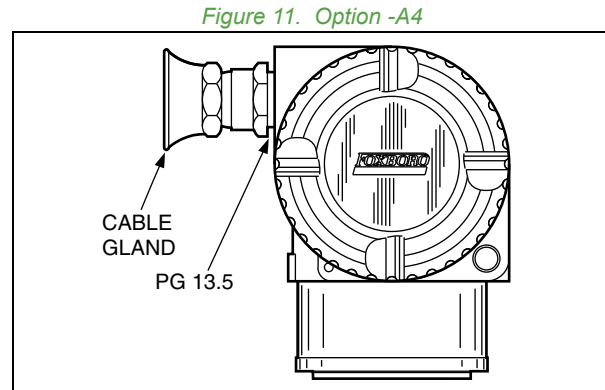

Table 3. Electrical Conduit Adapters Available with Electrical Safety Codes

Conduit Thread Adapter Code	Available with the Following Electrical Safety Codes:	
	Safety Code	Electrical Safety Code Description
A1, A2, A3, A4	E	ATEX II 1 G, EEx ia IIC, or II 1/2 G, EEx ib IIC
A1 and A3 only	D	ATEX II 2 G, EEx d IIC
A1 and A3 only	N	ATEX II 3 G, EEx n IIC
A1 and A3 only	M	ATEX Multiple Certifications (includes Codes E, D, and N above)

PROCESS RELATED OPTIONS – BOLTING, DEGREASING, AND CLEANING

**Options -B1/-B2: 316 ss or 17-4 ss Bolting**

For d/p Cell style transmitters with traditional or low profile structures. Either 316 ss or 17-4 ss bolts and nuts are provided, as specified. See table below for pressure ratings with these options. Not available with DIN 19213 construction options, or Structure Codes 78 and 79 (pvdf inserts). See Figure 12.

Model Code Suffix	Description	Static Pressure Rating	Proof Pressure Rating
-B1	316 ss Bolts and Nuts	15 MPa (a)(2175 psi)	60 MPa (8700 psi)
-B2	17-4 ss Bolts and Nuts	25 MPa (b)(c)(3625 psi)	100 MPa (14 500 psi)

- a. Option -B1 is derated to the value listed. Pressure with standard B7 bolting is 25 MPa (3625 psi)
- b. There is no pressure derating with the -B2 option (value listed is same as standard B7 bolting). Not available with Option -X3 since 17-4 ss bolts and nuts are provided with the -X3 option
- c. Max static pressure for IGP20 F range is 34.5 MPa (5000 psi)

**Option -B3: B7M Bolting (NACE)**

For d/p Cell style transmitters with traditional or low profile structures. Invensys offers NACE Class II bolting where the bolting is directly exposed to sour environments, will be buried, insulated, or otherwise denied atmospheric exposure, or if the bolting may be exposed to sour environments through leakage, bleeding of vent screws, etc. This bolting is in accordance with ASTM A193 Gr. B7M and A194 Gr. 2HM (Nuts). Not available with DIN 19213 construction options, or Structure Codes 78 and 79 (pvdf inserts). See table below and Figure 12.

Model Code Suffix	Description	Static Pressure Rating (a)	Proof Pressure Rating
-B3	B7M Bolts and Nuts	20 MPa (2900 psi)	70 MPa (11 150 psi)

- a. This is derated pressure. Pressure with standard B7 bolting is 25 MPa (3625 psi).

Figure 12. Options -B1, -B2, and B3

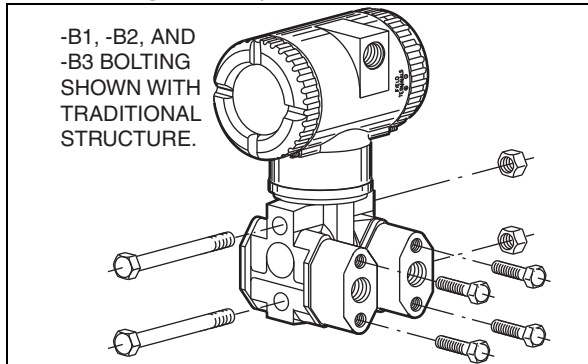

### NACE MR 01-75 Service

Used in sour gas service. All metallic, process wetted parts comply with NACE Standard MR 01-75 for resistance to sulfide stress cracking. For additional information on material conformance to NACE, refer to TI 005-102.

"AS" Reference Code	Description
MR-01	Compliance of Foxboro Instruments with NACE Standard MR 01-75

### Option -X1: Special Degreasing

For transmitters with silicone filled sensors only. Transmitter is cleaned, calibrated, labeled, and packaged in a Clean Room. NOT FOR USE ON OXYGEN, CHLORINE, OR OTHER FLUIDS THAT MAY REACT WITH SILICONE OIL. Also not available with gold-plated sensor.

Model Code Suffix	Description
-X1	Special Degreasing (a)

- a. For transmitters with silicone filled sensors only.

### Options -X2/-X3: Oxygen or Chlorine Service Cleaning

For transmitters with inert filled sensors only. Transmitter is cleaned, calibrated, labeled, and packaged in a Clean Room. Oxygen or chlorine service not offered when carbon steel process covers or the gold-plated sensor is used.

Model Code Suffix	Description
-X1	Silicone Filled Sensors
-X2	Oxygen Service Cleaning (a)
-X3	Chlorine Service Cleaning (a) (b)

- a. For transmitters with inert filled sensors only.
- b. Not available with Option -B2.

#### NOTE

Degreasing and Oxygen/Chlorine Service Cleaning options (-X1, -X2, -X3) are not available with transmitters having direct connect pressure seals, or having integral process connectors such as for sanitary, pulp and paper, and high gauge pressure processes.

**PROCESS CONNECTIONS, VENT SCREWS, AND CALIBRATION SCREW**

For process connections relating to special purpose applications, see the sections on pressure seals, sanitary industry and pulp and paper industry processes, and for transmitters with integrally mounted manifolds.

**Options -E1 to -E4: Tubing Connectors**

For d/p Cell style Transmitters. Compression fittings for connecting 6 or 12 mm tubing to process connections. See Figure 13.

Model Code Suffix	Description
-E1	Connector, 6 mm, 1/4 NPT, cs
-E2	Connector, 12 mm, 1/2 NPT, cs
-E3	Connector, 6 mm, 1/4 NPT, ss
-E4	Connector, 12 mm, 1/2 NPT, ss

Figure 13. Options -E1 to -E4

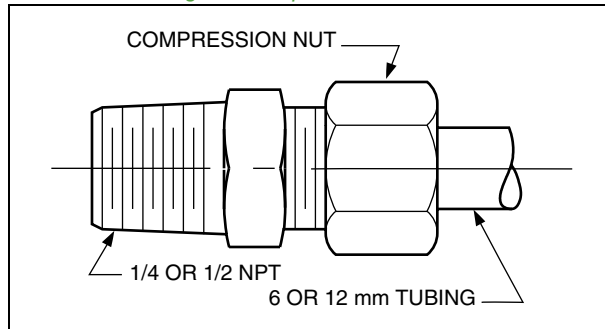

**Option -G: G 1/2 Form B Process Connection for Standard IAP10/IGP10 and IAP10S/IGP10S Transmitters with Span Limit Codes C, D, E, and F Only**

A G 1/2 thread replaces the standard 1/2 NPT thread. See Figure 14.

Model Code Suffix	Description
-G (a)	G 1/2 Form B External Thread

a. Not with transmitters having integral process connectors for sanitary, or pulp and paper processes, nor with pressure seals, nor with Option -V1.

Figure 14. Option -G

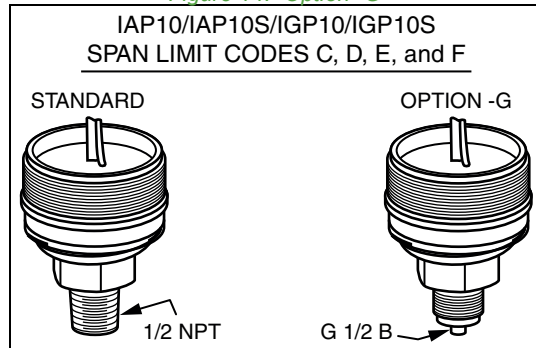

**Options -G/-G1/-G2: Process Connections for IGP10 High Gauge Pressure Transmitters with Span Limit Code G, H, and K, as applicable**

A G 1/2 Form B, an Autoclave F-250 C, or a 1/2 NPT connection replaces the standard 1/4 NPT connection. See Figure 15.

Model Code Suffix	Description
-G	G 1/2 Form B External Thread
-G1	Autoclave F-250 C Internal Connection
-G2	1/2 NPT External Thread

Figure 15. Options G, -G1, and -G2

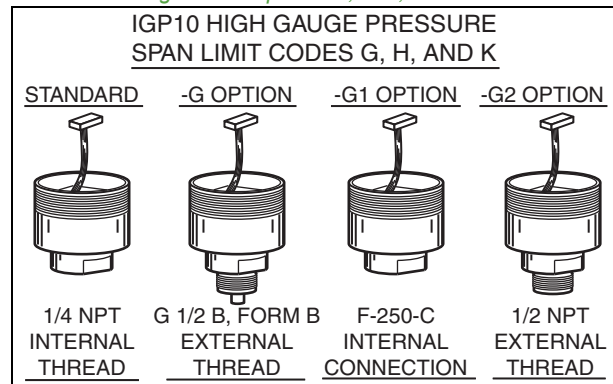

**Option -R: R 1/2 Process Connection Adapter IAP10/IAP10S/IGP10/IGP10S with Span Limit Codes C, D, E, and F**

Adapts a 1/2 NPT to a R 1/2 process connection. See Figure 16.

Model Code Suffix	Description
-R (a)	R 1/2 Process Connection Adapter

- a. Not with Structure Codes 24, 26, 28, 30, 31, 32, 33, S3, S4, SC, SD; or with transmitters having integral process connectors for sanitary, and pulp and paper processes.

Figure 16. Option -R

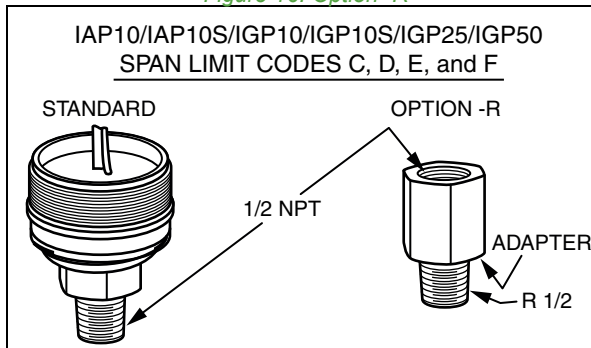

**Option -V: Vent Screw in Process Cover(s)**

Vent screw(s) provided to vent each cavity as shown in figure below. The user may invert the transmitter cover(s) and use the vent screw as a bottom drain. See Figure 17.

Model Code Suffix	Description
-V	Vent Screw in Side(s) of Process Cover(s), as follows: <ul style="list-style-type: none"> <li>▶ Hi-LO Sides: IDP10, IDP10S, IDP25, IDP50, IMV25, IMV30, and IMV31.</li> <li>▶ Hi Side Only: IAP20 and IGP20</li> </ul>

Figure 17. Option -V

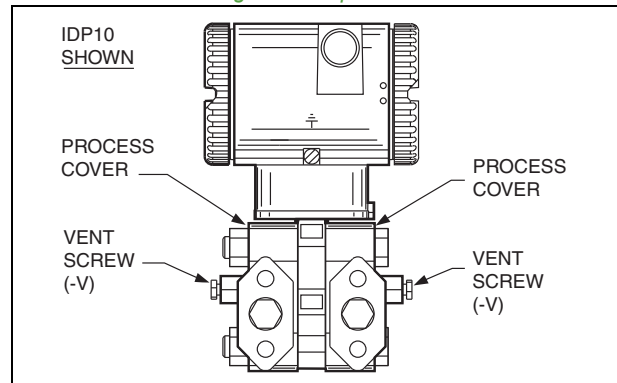

**Calibration Screw**

Allows DP or GP transmitter with block and bleed valve to be easily calibrated without removing it from process. See Figure 18.

Part No.	Description
F0101ES	Calibration Screw; use with Poly-Flo fitting (to 0.7 MPa [100 psi])

**Option -V1: Vent Screw in Process Connector**

For quick and easy venting of a direct connected transmitter. Not with seals. See Figure 18.

**Options -V2, -V3, -V4: Block and Bleed Valves**

See Figure 18 and MANIFOLDS section.

Figure 18. Options -V1 to -V4 and Calibration Screw Option

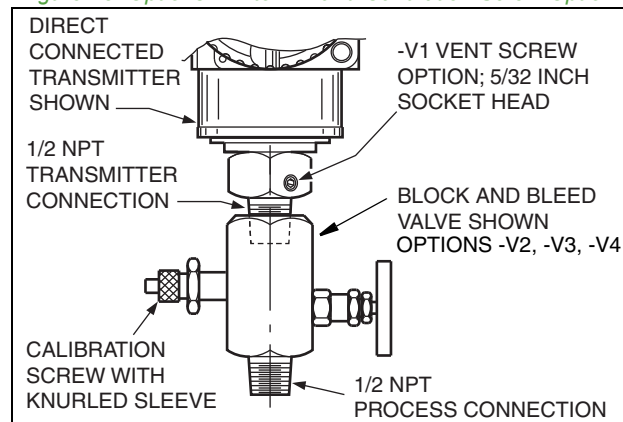

**Options -D1 to -D9: DIN 19213 Construction**

Process Covers (316 ss only) used with d/p Cell style transmitters when Process Connector Code “0” is selected. These options have the pressure ratings listed in the table below. See Figure 19.

DIN 19213 Option	Pressure Rating
-D9	40 MPa (5800 psi) (a)
-D3, -D7; standard rating	25 MPa (3625 psi) (b)
-D1	16 MPa (2320 psi) (c)
-D5	15 MPa (2175 psi) (c)
-D2, -D4, -D6, -D8 (d)	10 MPa (1500 psi) (c)

- a. Option -D9 has a higher rating than standard (see Note b).
- b. Standard pressure rating is 25 MPa (3625 psi).
- c. Options -D1, -D2, -D4, -D5, -D6, and -D8 are derated as listed.
- d. Options D2, -D4, -D6, -D8 limited to 0 to 60°C (32 to 140°F).

Figure 19. Options -D1 to -D9

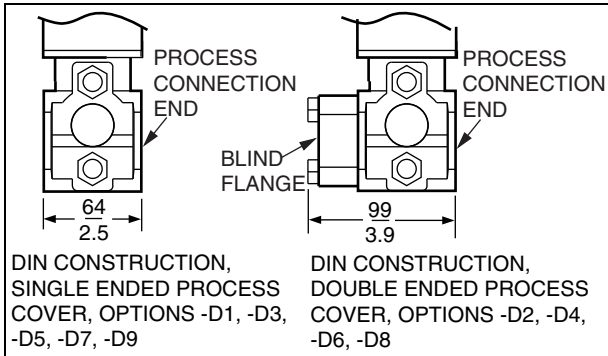

Model Code Suffix	Description
-D1 (a)	Single Ended Process Cover, M10, B7 Steel Bolting
-D2 (a) (b)	Double Ended Process Cover, M10, B7 Steel Bolting/Blind Flange
-D3 (a)	Single Ended Process Cover, 7/16 in, B7 Steel Bolting
-D4 (a) (b)	Double Ended Process Cover, 7/16 in, B7 Steel Bolting/Blind Flange
-D5 (a)	Single Ended Process Cover, 7/16 in, 316 ss Bolting
-D6 (a) (b)	Double Ended Process Cover, 7/16 in, 316 ss Bolting/Blind Flange
-D7 (a)	Single Ended Process Cover, 7/16 in, 17-4 ss Bolting
-D8 (a) (b)	Double Ended Process Cover, 7/16 in, 17-4 ss Bolting/Blind Flange
-D9 (a) (c) (d)	Single Ended Process Cover, 7/16 in, 17-4 ss

- a. Not available with pressure seals.
- b. Not available with Mounting Bracket Sets.
- c. Not with Span Codes A, D, E, or Options -B1, -B2, -B3, -V, -Y.
- d. Not with IMV25, IMV30, or IMV31 Multivariable Transmitters.



MOUNTING BRACKET SETS

The I/A Series Transmitters, because of their small size and lightweight design, are often self-supported by the process piping, making the installation quicker, easier, and less expensive. Mounting Bracket Sets, however, are offered for installations that require pipe stand mounting. Also, refer to the MANIFOLDS section for AGCO mounting sets that have been specifically designed for use with manifold/transmitter assemblies.

**Options -M1 to -M8: Mounting Bracket Sets For IAP10, IAP10S, IGP10, IGP10S, IGP25, and IGP50 Transmitters**

Used for all direct connect type transmitters when the transmitter is connected to the process using a capillary, rather than directly mounting the transmitter to the process connection. The transmitter attaches to a mounting bracket, which then attaches to user-supplied horizontal or vertical DN 50 or 2-in pipe. See Figures 20 and 21.

Model Code Suffix	Mounting Bracket Set Description	Connection to Process	Offered with Flameproof Transmitter
-M1	Painted Steel Bracket; Plated Steel Bolts; 1/2 NPT	Capillary	No
-M2	Stainless Steel Bracket; Stainless Steel Bolts; 1/2 NPT	Capillary	No
-M3	Painted Steel Bracket; Plated Steel Bolts; PG 13.5 (a)	Capillary	No
-M4	Stainless Steel Bracket; Stainless Steel Bolts; PG 13.5 (a)	Capillary	No
-M5	Painted Steel Bracket; Plated Steel Bolts; M20	Capillary	No
-M6	Stainless Steel Bracket; Stainless Steel Bolts; M20	Capillary	No
-M7	Stainless Steel Bracket; Stainless Steel Bolts (IAP10/IAP10S/IGP10/IGP10S Flameproof transmitters only)	Capillary	Yes
-M8	Painted Steel Bracket; Plated Steel Bolts (IAP10/IAP10S/IGP10/IGP10S Flameproof transmitters only)	Capillary	Yes

a. Not available with IAP10S or IGP10S Flameproof transmitters.

Figure 20. Mounting Bracket Sets for IAP10, IAP10S, IGP10, IGP10S, IGP25, and IGP50 Transmitters

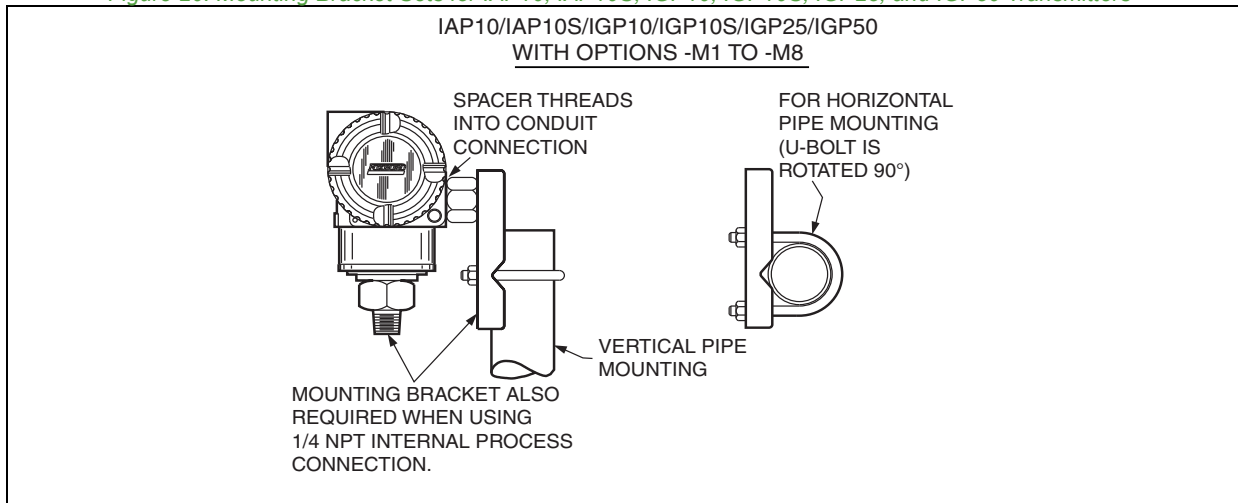
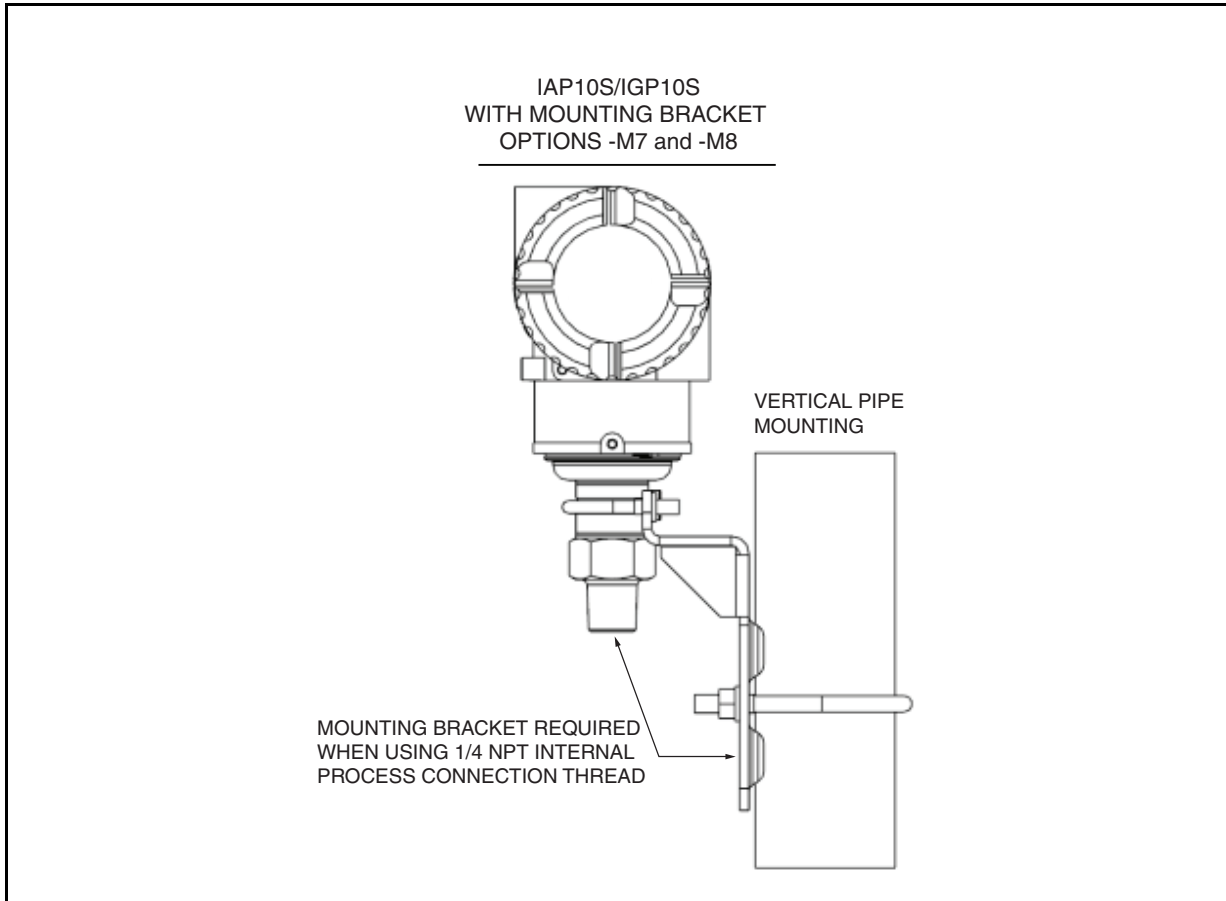

Figure 21. Mounting Bracket Sets for IAP10/IAP10S/IGP10/IGP10S Flameproof Transmitters



**Options -M1 to -M3: Mounting Bracket Sets for IAP20 and IGP20 Transmitters**

A standard and universal style mounting bracket is offered. These brackets attach to the transmitter bottomworks. The standard bracket (Options -M1 and -M2) provide for conventional transmitter mounting, while the universal bracket (Option -M3) allows for numerous mounting configurations. The transmitter attaches to a mounting bracket, which then attaches to a user-supplied DN 50 or 2-in pipe. See Figure 22.

Model Code Suffix	Mounting Bracket Set Description
-M1	Standard Style; Painted Steel Bracket and Plated Steel Bolts.
-M2	Standard Style; Stainless Steel Bracket and Stainless Steel Bolts.
-M3	Universal Style; Stainless Steel Bracket and Stainless Steel Bolts.

Figure 22. Mounting Bracket Sets for IAP20 and IGP20 Transmitters

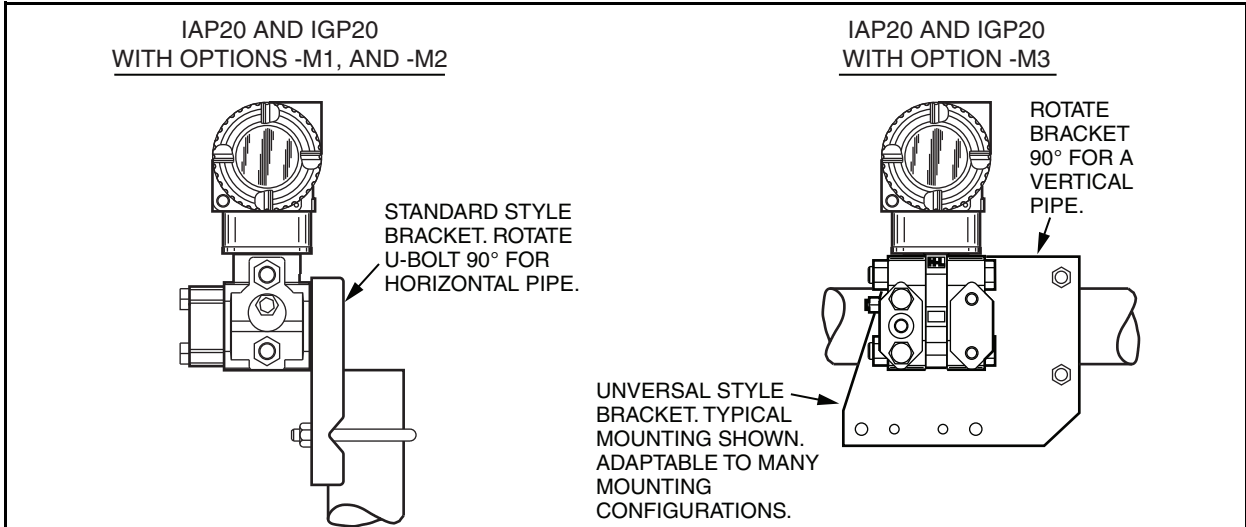

**Options -M1 to -M3: Mounting Bracket Sets for IDP10, IDP10S, IDP25, IDP50, IMV25, IMV30, and IMV31 Transmitters**

As with the IAP20 and IGP20 transmitters, a standard and universal style mounting bracket is offered. The standard mounting brackets (-M1 and -M2) are for use with traditional and LP2 (low profile) structures. The universal bracket (-M3) is for use with traditional and both LP1 and LP2 low profile structures and is adaptable to many mounting configurations. See Figure 23.

Model Code Suffix	Mounting Bracket Set Description
-M1 (a)	Standard Style; Painted Steel Bracket and Plated Steel Bolts.
-M2 (a)	Standard Style; Stainless Steel Bracket and Stainless Steel Bolts.
-M3	Universal Style; Stainless Steel Bracket and Stainless Steel Bolts.

a. Standard style bracket Options -M1 and -M2 are not available with Low Profile Structure LP1.

Figure 23. Mounting Bracket Sets for IDP10, IDP10S, IDP25, IDP50, IMV25, IMV30, and IMV31 Transmitters

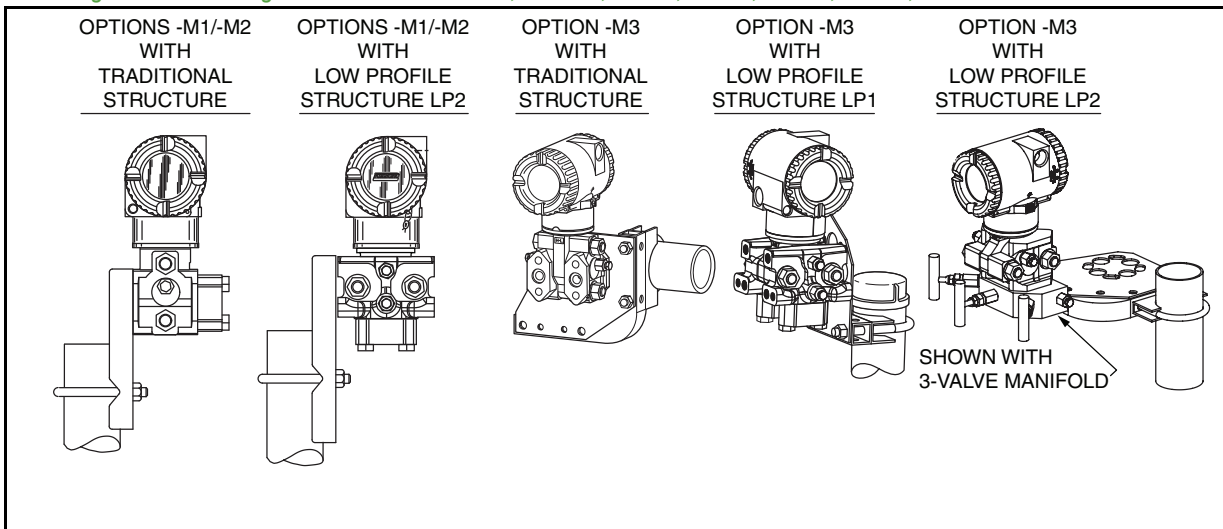

MISCELLANEOUS PRODUCT ENHANCING OPTIONS

**Options -Z1 to -Z3: Electronics Housing Features**

Refer to Figure 24.

Model Code Suffix	Description
-Z1 (a)	External Zero Adjustment
-Z2	Custody Transfer Cover Locks and Seals
-Z3 (a)	Both External Zero Adjustment and Custody Transfer Cover Locks and Seals

a. Not offered with IMV25, IMV30, and IMV31 Multivariable Transmitters.

**External Zero Adjustment**

An external, moisture sealed pushbutton is provided on the electronics housing. This zero adjust pushbutton function is non-intrusive and magnetically operated through the housing. This allows the user to locally reset zero without removing the housing cover. Not offered with IMV25, IMV30, or IMV31 Multivariable Transmitter.

**Custody Transfer Lock and Seal**

Offered for use in custody transfer applications. Two set screws are used to position and lock the two housing covers after they are fully engaged. Two approved custody transfer seals are used to indicate entry into the electronics housing.

**External Zero Adjustment and Custody Transfer Lock and Seal**

This option provides both External Zero Adjustment and Custody Transfer Lock and Seal. Not offered with IMV25, IMV30, or IMV31 Multivariable Transmitter.

Figure 24. Options -Z1 to -Z3

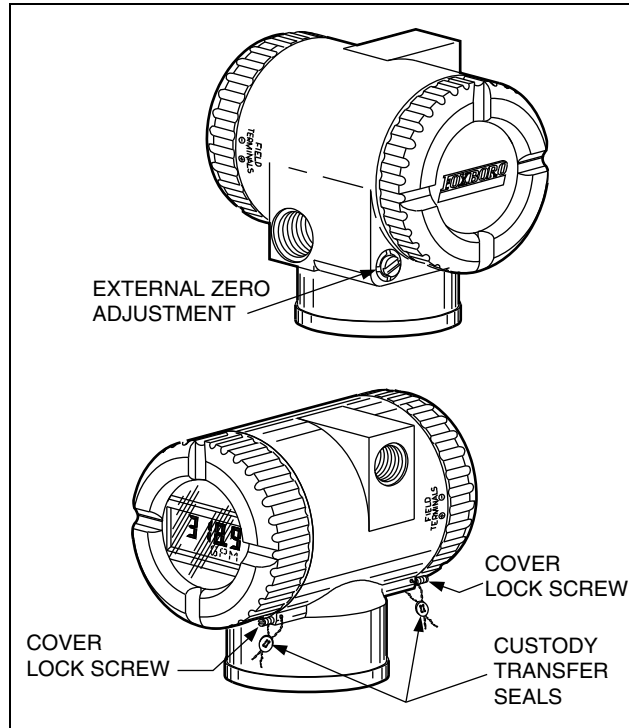

**Standard Data Plate**

All Transmitters are supplied with a stainless steel data plate using embossed or etched characters. The data plate encircles the neck of the electronics housing, and is secured. If sales order is supplied with tag data, this data is automatically included on the data plate (approximately thirty characters). For additional tag space, refer to "Supplemental Customer Tag". See Figure 25.

Figure 25. Standard Data Plate and Supplemental Customer Tag

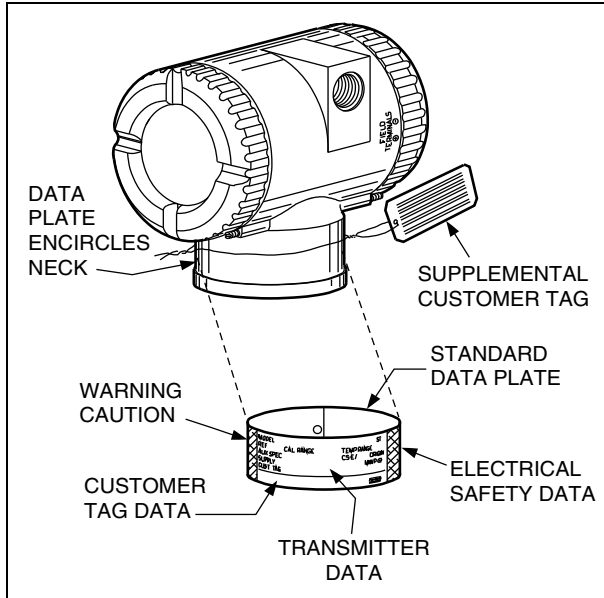

**Option -T: Supplemental Customer Tag**

The standard, permanently-attached, stainless steel data plate provides one line of space, 76 mm (3 in) long for customer tagging information. This option adds a 90 x 40 mm (3.5 x 1.5 in) stainless steel tag, for additional customer data. The tag is fastened to the transmitter with stainless steel wire. See Figure 25.

Model Code Suffix	Description
-T	Supplemental Customer Tag

**Quality Assurance Certificates**

Invensys offers certificates for parts and products to satisfy the needs of many customers. Quality assurance certificates offered are for compliance, conformance, material and parts, calibration, pressure test, cleaning, weight, SASO, SIL2, electrical safety classifications, and custom certificates not listed above. Refer to the following table and to TI 037-094 for a detailed description of the certificates.

Order by Specifying	Description
CERT-A	Certificate of Compliance/Quality Statement
CERT-B	Certificate of Conformance
CERT-C	Material Certificate (Typical) Listing, Description, and Conformance statements
CERT-D	Material Certificate - Same as CERT-C except material certificates are included in package.
CERT-E	Calibration Certificate
CERT-F	Certificate of Hydrostatic/Pressure Test
CERT-G	Certificate of Cleaning
CERT-H	Weight Certificate
CERT-I	SASO Certificate
CERT-J	Cover Sheet
CERT-K	Certificate of Compliance/Quality Statement
CERT-S	SIL2 TUV (Rheinland) Certificate; Certified Transmitters where applicable
Other	Contact Invensys

**Option -S2: SIL2 Certified HART Transmitters**

Safety Integrity Level (SIL2) transmitters are offered with Models IAP10, IGP10, IAP20, IGP20, and IDP10 Transmitters having HART communication protocol.

Modern industrial processes tend to be technically complex and have the potential to inflict serious harm to persons or property during a mishap. The IEC 61508 standard defines safety as “freedom from unacceptable risk.” SIL2 pressure transmitters with HART communication protocol, in conjunction with Triconex Safety Systems, provide integrated solutions for safety and critical control applications. The integrated solution is certified as interference-free from the 4 to 20 mA loop; this guarantees the integrity of the safety system and the safety of the controlled process. The integrated design allows uninterrupted operation of the safety function, while allowing access to device level information via HART commands. The solution permits interface of device diagnostics with asset management systems without compromising functional safety.



A copy of the certification is available via Auxiliary Specification (AS) Code CERT-S for SIL2 TUV (Rheinland) certified safety pressure transmitters. (See previous Quality Assurance Certificates paragraph).

**Option -W: Seventeen Year Warranty**

The standard five-year warranty is increased to a seventeen year warranty. In either case, the I/A Series Pressure Transmitters provide outstanding quality, service, and reliability that users have come to expect from Foxboro transmitters.

Model Code Suffix	Description
-W (a)	Seventeen Year Warranty

- a. Offered with the IGP25, IGP50, IDP25, and IDP50 Transmitters only.

**Option -Y: Static Pressure Rating Increase**

This option applies to the IDP10, IDP10S, IDP25, and IDP50 Transmitters only. This option increases the static pressure rating from 25 to 40 MPa (from 3625 to 5800 psi). See table below.

Model Code Suffix (a)	Description
-Y	Static Pressure Rating Extended to 40 MPa (5800 psi)

- a. - Only available with Span Limit Codes B and C
- Not available with Options -B1, -B2, -B3
- Not available with DIN Construction Options -D1 to -D9
- Not available with Structure Codes 34 and 35 (Monel sensors and covers), and 78 and 79 (pvdf insert in side covers).
- Not available with transmitters having pressure seals.

**Option -K1: Transmitter Instructions**

By default, a “Getting Started” brochure, a condensed Universal Master Instruction manual, and a DVD containing a full set of documentation are provided with every order of 5 transmitters. Alternately, in the “Notes” section of the worksheet, you can request that each transmitter is shipped with the Universal Master Instruction manual or that your order is shipped with a printed unabridged instruction manual for your specific product. Finally, if documentation is not required, specify the -K1 option.

**Option -J: Lowering of Operating Temperature Limit**

This option offered for transmitters having silicone filled sensors only. The low temperature operative limit of the electronics housing of -40°C (-40°F) is extended down to -50°C (-58°F). -50°C indicates sensor and electronics ambient temperature capabilities. Note that transmitter performance is not assured below -29°C, and sensor damage may occur if process is frozen.

Additionally, although the LCD indicator will not be damaged at these low temperatures, readability will start to decrease at temperatures below -35°C (-31°F).

Model Code Suffix (a)	Description
-J	Low Temperature Operative Limits of Electronics Housing Extended down to -50°C (-58°F)

- a. For transmitters having silicone filled sensors only.

**Shorting Bar, Plug-in**

The nominal supply voltage limits for many of these transmitters are 11.5 and 42 V dc. If required by the user, the 11.5 V dc minimum voltage can be reduced to 11 V dc by inserting a plug-in shorting bar across the test receptacles in the field wiring compartment terminal block. This option is not applicable to transmitters with Electronic Versions -F and -V, nor with the IMV25, IMV30, or IMV31 Multivariable Transmitters.

"AS" Reference Code	Description
SB-11	Plug-in Shorting Bar

Figure 26. Shorting Bar

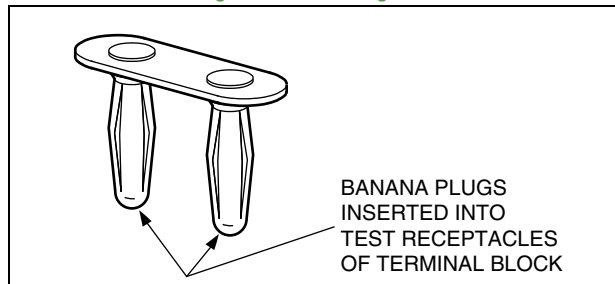

**Options -C1/-C2: Optional Custom Configurations**

Transmitter databases can be changed via:

- ▶ Electronic Version -D (FoxCom): PC-based configurator; I/A Series system; or optional LCD Indicator with on-board pushbuttons.
- ▶ Electronic Version -T (HART): HART Communicator; PC-based configurator; or optional LCD Indicator with on-board pushbuttons.
- ▶ Electronic Version -F (FOUNDATION Fieldbus): I/A Series system; PC host PWA; or optional LCD Indicator with on-board pushbuttons.
- ▶ Electronic Version -A (4 to 20 mA dc Analog Output): Standard LCD Indicator with on-board pushbuttons.
- ▶ Electronic Version -V (1 to 5 V dc Analog Output): Standard LCD Indicator with on-board pushbuttons.

Invensys modifies the default configuration when you select Optional Selection Code -C1 or -C2.

See tables in each transmitter PSS for the standard configuration, and an example of optional custom configuration -C2.

Model Code Suffix	Description
-C1	Digital Output Configuration (for Electronics Version -D only). There is a 4 to 20 mA default if Option -C1 is not selected. For S series transmitters (IAP10S, IGP10S, and IDP10S), if you want to override the default multiple calibration behavior, specify Option -C1 to replace multiple calibration settings with a custom 2-point calibration. Be sure to indicate the calibration range required in the sales order.
-C2	Custom Configuration. Factory Configuration per User's Requirement (User must fill out Data Form for factory to custom configure the Transmitter).

PRODUCT ACCESSORIES

Invensys stocks a wide variety of accessories to help tailor your installation. These accessories may be ordered by using the Part Numbers listed, or by contacting Invensys directly for application and other information.

**Power Supply**

This Acopian plug-in power supply is capable of powering as many as three transmitters with a 4 to 20 mA dc output signal. Each power supply requires an octal socket. See Figure 27.

Part No.	Description
P0300BR	Power Supply
B0113AA	Octal Socket

Figure 27. Power Supply



**Siphon Pigtail**

To rapidly reduce temperature at transmitter with a minimum of process piping. Pigtail is steel construction with 1/4 NPT threads at both ends. Approximately 115 mm (4.6 in) in length. Suitable to 14 MPa (2000 psi) at up to 340°C (650°F), or to 7 MPa (1000 psi) at up to 480°C (900°F). See Figure 28.

Part No.	Description
0005838	Siphon Pigtail

Figure 28. Siphon Pigtail



**Hand Valves**

For installation at process piping. Steel construction with 1/2 NPT internal thread at both ends. See Figure 29.

Part No.	Description
0046091	Valve for 10.5 MPa (1500 psi) at 38°C (100°F) maximum
0019883	Valve for 20 MPa (3000 psi) at 230°C (450°F) maximum

Figure 29. Hand Valve

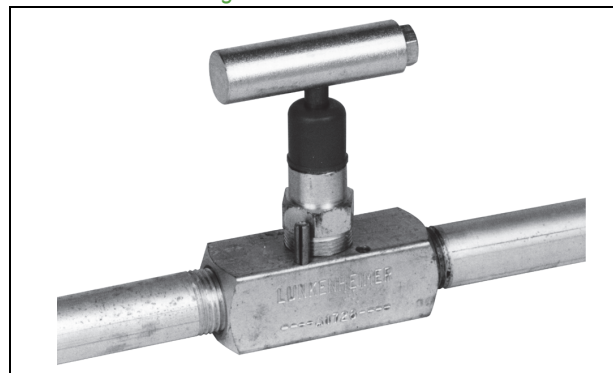

### Differential Pressure Regulator

Maintains a constant pressure drop to control the purge rate in purge or bubble tube systems. Refer to MI 11-170 and MI 020-328 for additional information. See Figure 30.

Part No.	Description
B0107XY	10 kPa (1.5 psi) Differential (Air Only)
B0107XX	20 kPa (3 psi) Differential (Liquid or Gas)

Figure 30. Differential Pressure Regulator



### Flexible Hose Connector

Anchor coupling or Dayco braided hose with 1/4 NPT swivel connections for use as impulse piping between process and transmitter. Pressure to 17.5 MPa (2500 psi). See Figure 31.

Part No.	Description
B0110EB	3 ft Hose
B0110EC	6 ft Hose

Figure 31. Flexible Hose Connector

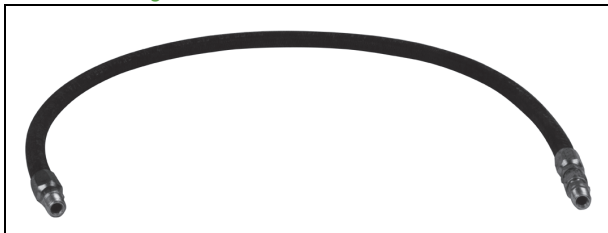

### Rotameter

For control of purge rate and visual indication in a purge or bubble tube system. For additional details refer to Instruction Manuals MI 005-529 and MI 020-328. See Figure 32.

Suitable for gas or liquid purges up to 1.4 MPa (200 psi) at 70°C (160°F). See descriptions below.

Part No.	Description
D0105NX	0.2 to 30 scfh (Gas), or 0.1 to 5 gph (Liquid)
D0105PF	5 to 60 scfh (Gas)
D0105PB	4 to 40 gph (Liquid)
M0153YM	5 to 200 mL/s (Gas), or 0.1 to 5 mL/s (Liquid)
M0153YN	20 to 500 mL/s (Gas)
M0153YP	5 to 40 mL/s (Liquid)

Suitable for gas or liquid purges up to 1.4 MPa (200 psi) at 90°C (200°F). See descriptions below.

Part No.	Description
D0127MF	0.2 to 30 scfh (Gas), or 0.1 to 5 gph (Liquid)
D0127ML	5 to 60 scfh (Gas)
D0127MK	4 to 40 gph (Liquid)

Figure 32. Rotameter

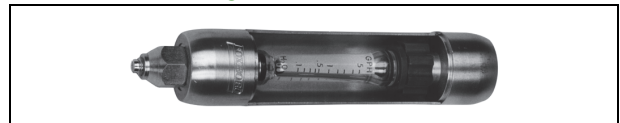

### Pressure Snubbers

For installation in the process line to reduce or eliminate any unwanted pressure pulsations, 1/4 NPT at both ends. See table below.

Part No.	Description
0045162	Brass, 1500 psi (100 Bar) For air, water, or steam
0045163	303 ss, 5000 psi (340 Bar) For thin liquids and gases
0044596	Brass, 1500 psi (100 Bar) For oils and thick liquids
0044597	303 ss, 5000 psi (340 Bar) For oils and thick liquids

### Leveling Pipe Saddle

For quick and easy attachment of a DN 50 or 2-in mounting pipe to another pipe. Saddle is cast iron and includes U-bolts and nuts. For pipe sizes larger than DN 150 or 6 in, contact Invensys.

Part No.	Description
0032017	For DN 50 or 2-in Pipe
0046935	For DN 80 or 3-in Pipe
0016508	For DN 100 or 4-in Pipe
0036694	For DN 150 or 6-in Pipe

Figure 33. Leveling Pipe Saddle

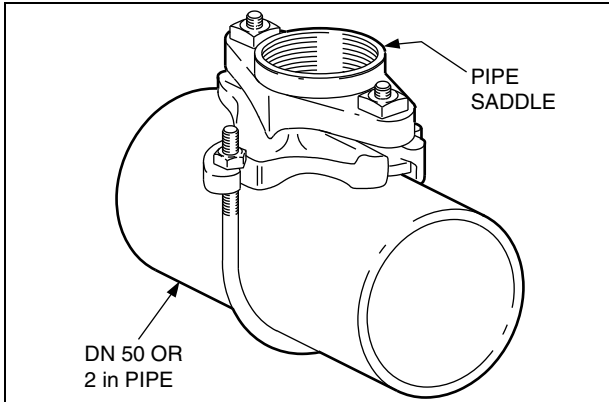

### Condensing Chamber

Good for steam service up to 7 MPa (1000 psi) absolute at 510°C (950°F) if condensing chamber temperature does not exceed 340°C (650°F). Chamber has 1/2 NPT connections with top vent screw assembly.

Part No.	Description
0045776	Condensing Chamber

Figure 34. Condensing Chamber



### Vapor Trap

A vapor trap is for installation at the manifold when the manifold is above the transmitter and transmitter is above the process line. Available for applications where the pressure does not exceed 140 bar (2000 psi).

Part No.	Description
0022817	Vapor Trap

### Laboratory Flow Calibration

Precision flow calibration of primary device and d/p Cell Transmitters are performed in the Invensys Flow Laboratory. Contact Invensys for further information. See Figure 35.

Figure 35. Laboratory Flow Calibration

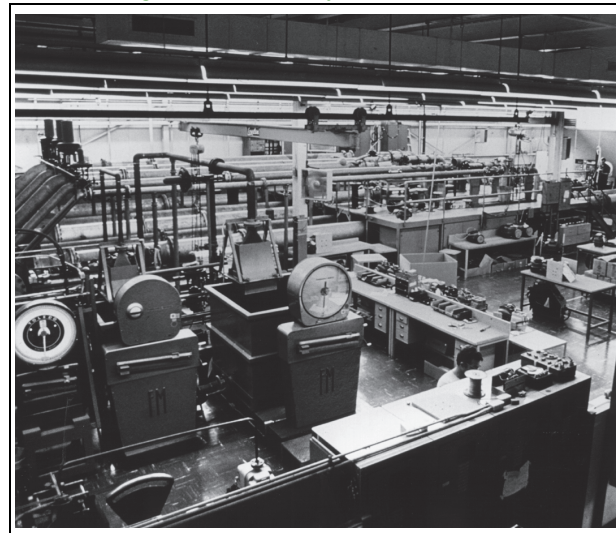



### Other Primary Devices

In addition to orifice plates and orifice assemblies, flow nozzles and venturi tubes are used as primary devices and are directly installed in the pipeline. Contact Invensys to specify your requirements. See Figure 36.

*Figure 36. Other Primary Devices*

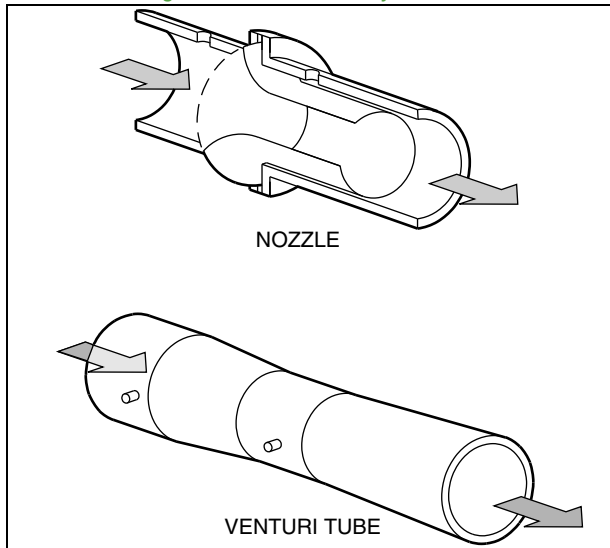

CALIBRATION

Most I/A Series Pressure Transmitters are factory calibrated to customer's specified range. This calibrated range is also stamped on the data plate. If a calibrated range is not specified, the transmitter will be calibrated at its maximum span with the data plate left blank. Calibrations are done at ambient temperature and pressure.

The I/A Series S Series pressure transmitters (IAP10S, IGP10S, and IDP10S) offer multiple calibration technology, which eliminates the need for a traditional single span calibration at an application-specific pressure range. The S Series transmitters can be ordered with the multiple calibration feature enabled or with the traditional two-point factory calibration applied over the user-specified range.

Transmitters with the multiple calibration feature enabled use multiple calibrated ranges that are stored in on-board memory. The calibrated ranges are preset in the factory and cover the full pressure range of the transmitter. During operation, a real-time, seamless transition from one calibrated range to another maintains digital accuracy as a percent of reading from 3% to 100% of the upper range limit (URL).

The following is a 5-point check, sample calibration certificate which can be provided (note, computer-generated calibration available from Foxboro, MA only).

FOXBORO, MASS., U. S. A. CALIBRATION DATA SHEET						
Customer			Date 5 Dec 2001 Time 06:45			
Customer P.O.			Cal. by DB Dept. 1329			
Customer Tag -						
Foxboro Order Serial # 01481168			Inst. type IDP10-T HRTCOM			
Range			0.0000 to 60.0000 Mm H2O			
Actual input in Mm H2O	Actual output in Mm H2O		Digital error in % of Span		Analog error in % of Span	
	Inc.	Decr.	Inc.	Decr.	Inc.	Decr.
.005	.014		+ .02		+ .01	
15.015	15.035		+ .03		+ .02	
30.005	30.017		+ .02		+ .03	
44.994	45.003		+ .01		+ .03	
60.002	60.009		+ .01		+ .03	
Max. Digital ERROR	.03 % at 25 % of Span					
Max. Analog ERROR	.03 % at 75 % of Span					
(FOR SALES ORDER REQUIREMENTS ONLY)						
			Approved by _____			
S7G1			Title _____			
All measurement standards are calibrated at scheduled intervals against certified standards which are traceable to the National Institute of Standards and Technology.						
Form 2759A(1/93)						

COMPACT ORIFICES, ORIFICE ASSEMBLIES, AND ORIFICE PLATES

**Compact Orifice - Model CO**

The Model CO Compact Orifice is a wafer body orifice plate that includes an integral three-valve manifold. This rugged, one-piece unit mounts directly to a d/p Cell style pressure transmitter. An alignment ring and an optional installation kit provide the hardware necessary to properly install the orifice in various pipeline sizes ranging from DN 15 to DN 100, or 1/2 to 4 inches. They are offered with either DIN or ANSI flanges. Alignment rings for use with the DIN or ANSI flanges are provided to accurately center the concentric orifice within the pipeline, and to generally simplify the entire installation procedure.

This orifice/manifold assembly is shipped directly assembled to either an IDP10, IDP10S, IDP25, IDP50, IMV25, or IMV30 Transmitter. The figures below show the assembly relationship of the various components when used with d/p Cell style transmitters having a traditional structure, an LP1 low profile structure, or an LP2 low profile structure.

Beta ratios of 0.40 or 0.65 can be selected with each orifice size. These betas are optimal for most concentric orifice flow applications.

The direct mounting of the orifice to the transmitter eliminates field interconnections, provides more consistent and improved performance when compared to remote transmitter installations, and reduces overall assembly and field installation costs.

The compact orifice can be used with clean liquids, gases, and low velocity steam. The orifice and transmitter are ordered separately, but shipped as one assembled unit. Refer to the applicable PSSs listed in the table that follows for compact orifice and transmitter specifications and ordering instructions. Also see Figures 37 and 38.

**Compact Orifice and Transmitter PSSs**

Model	Description (a)	Specify Model Number From
CO	Compact Orifice	PSS 3-5A1 E
IDP10/IDP10S	DP Transmitter	See Tables 1 and 2
IDP25	MR Transmitter	See Table 1
IDP50	PP Transmitter	See Table 1
IMV25	MV Transmitter	See Table 1
IMV30	MV Transmitter	See Table 1

a. DP = Differential Pressure, MR = MultiRange, PP = Premium Performance, and MV = MultiVariable.

**Integral Flow Orifices**

A wide variety of integral flow orifices, for use with d/p Cell transmitters, are offered for measurement of extremely low flow rates. They are available as in-line (Model IFO) or U-bend (Model IFOU) types that mount integral to the process connectors. They are also offered as assemblies that mount directly to the process connector or manifold and that feature no flow through the transmitter body (Model IFOA). The orifice plates themselves are easily replaceable. See table below, and “Typical Integral Flow Orifice Configurations” on page 28.

Model	Specify Model Number From
IFOA	PSS 3-5A1 B
IFOU	PSS 3-5A1 C
IFO	PSS 3-5A1 D

Figure 37. Typical Compact Orifice/Manifold/Transmitter Configurations

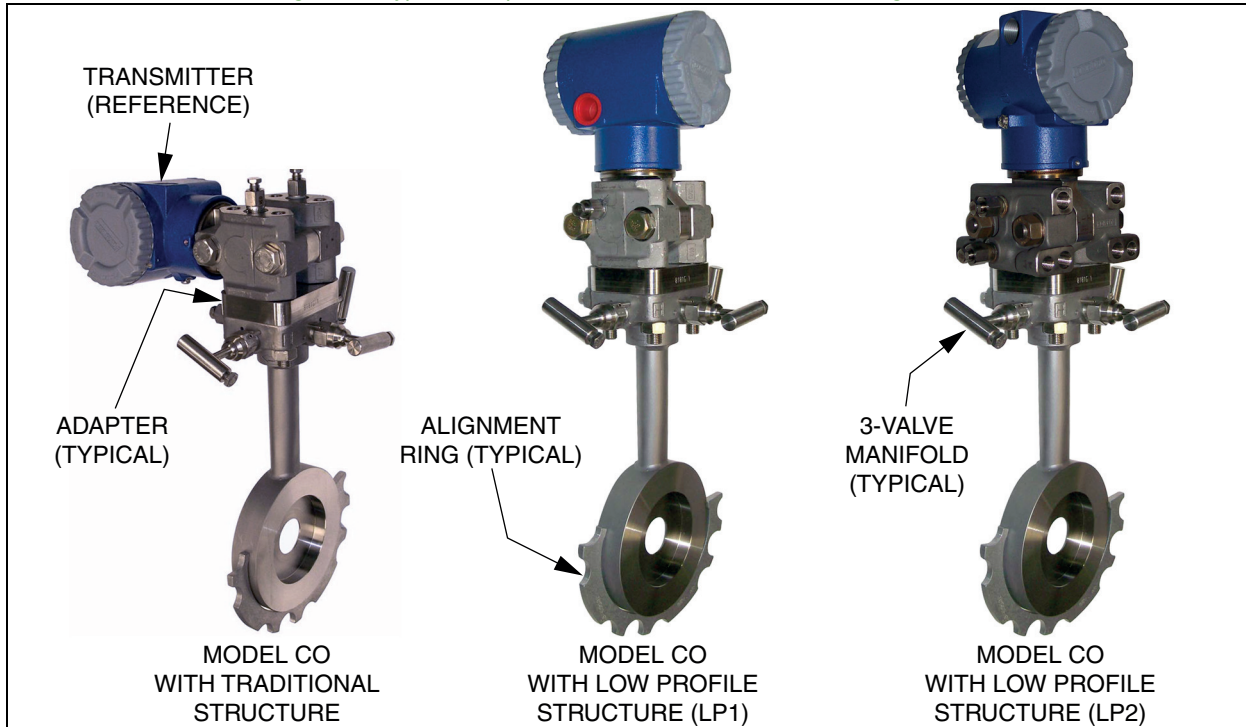
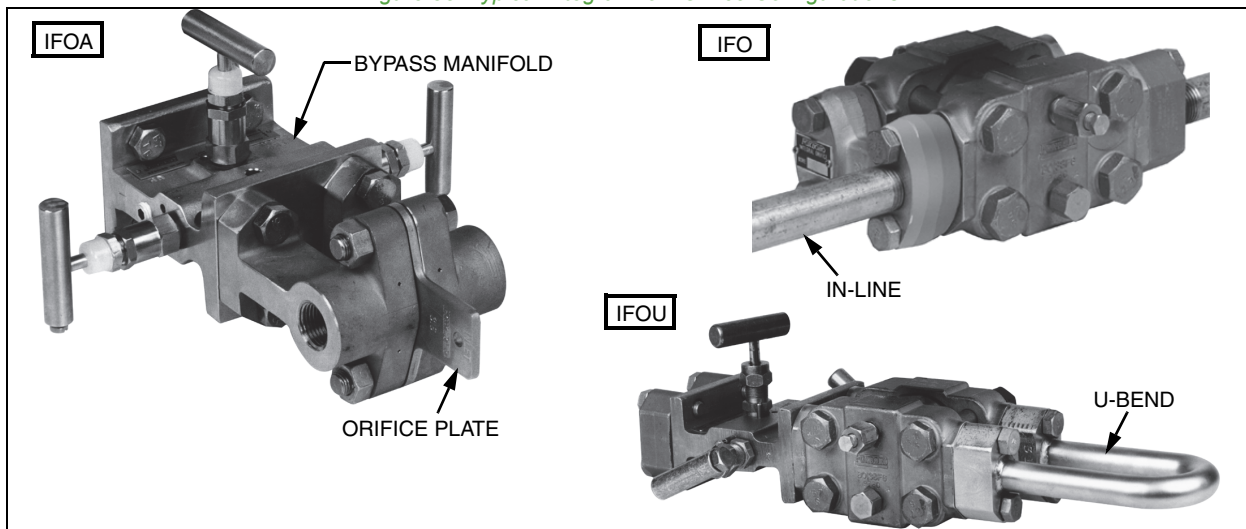

Figure 38. Typical Integral Flow Orifice Configurations



**Orifice Plates**

An orifice plate is used for installation in a pipeline. A square edge orifice plate is a very common and popular restriction for clean liquids, gases, and low velocity steam in 2-inch and larger pipe sizes. They are available in a wide selection of materials and sizes. Orifice plate holding rings, orifice plate spacers, orifice flange unions, and orifice meter pipe assemblies are offered. Contact Invensys for details on the square edged orifice plate, and also other special purpose plates (eccentric and segmental) available as low cost alternatives for troublesome applications.

*Figure 39. Orifice Plates*

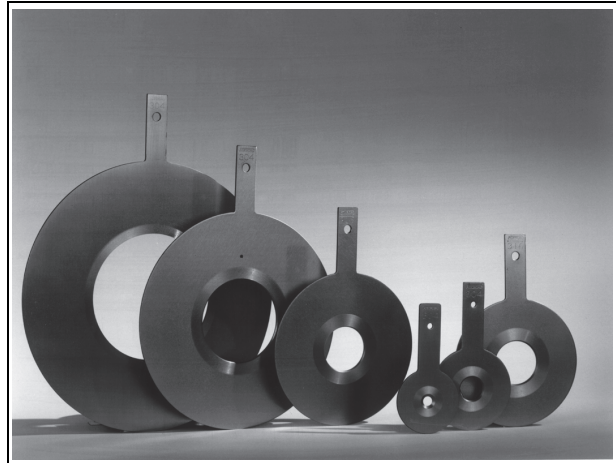

**PRESSURE SEALS FOR I/A SERIES PRESSURE TRANSMITTERS (IASPT)**

**Pressure Seals**

Many styles are available for use with AP, GP, and DP transmitters. Seals are used to isolate the transmitter from corrosive or viscous process mediums, or mediums that tend to solidify. They can be direct-connected or used with capillary tubing. The pressure seal system is filled with a suitable fluid. GP versions with integral end connections specifically for sanitary, and pulp and paper applications are also available. (See applicable sections further in document.)

Tables 4 and 5 identify the different pressure seals available and their applicability with each transmitter, and the figure below shows different seal configurations. Also, seals are shipped assembled to the transmitter as a matched system. Both transmitter and Seal Model Numbers are required.

See the applicable transmitter PSS and Pressure Seal PSS 2A-1Z11 E for further information and ordering instructions. Also see Vacuum Service Metal Gasket (Option -G1) that follows.

**Option -G1: Vacuum Service Metal Gasket**

This is a required option when pressure seals are used with IDP10, IDP10S and IGP20 transmitters in vacuum applications. This option substitutes a vacuum service metal gasket for the standard PTFE process cover gasket. The metal gasket is standard with IAP20 Transmitters. See table below.

Model Code Suffix (a)	Description
-G1	Gasket for vacuum service with seals

a. Available only with seal Structure Codes F1-F4, S1-S6, and SA-SF.

Figure 40. Typical Pressure Seal Configurations

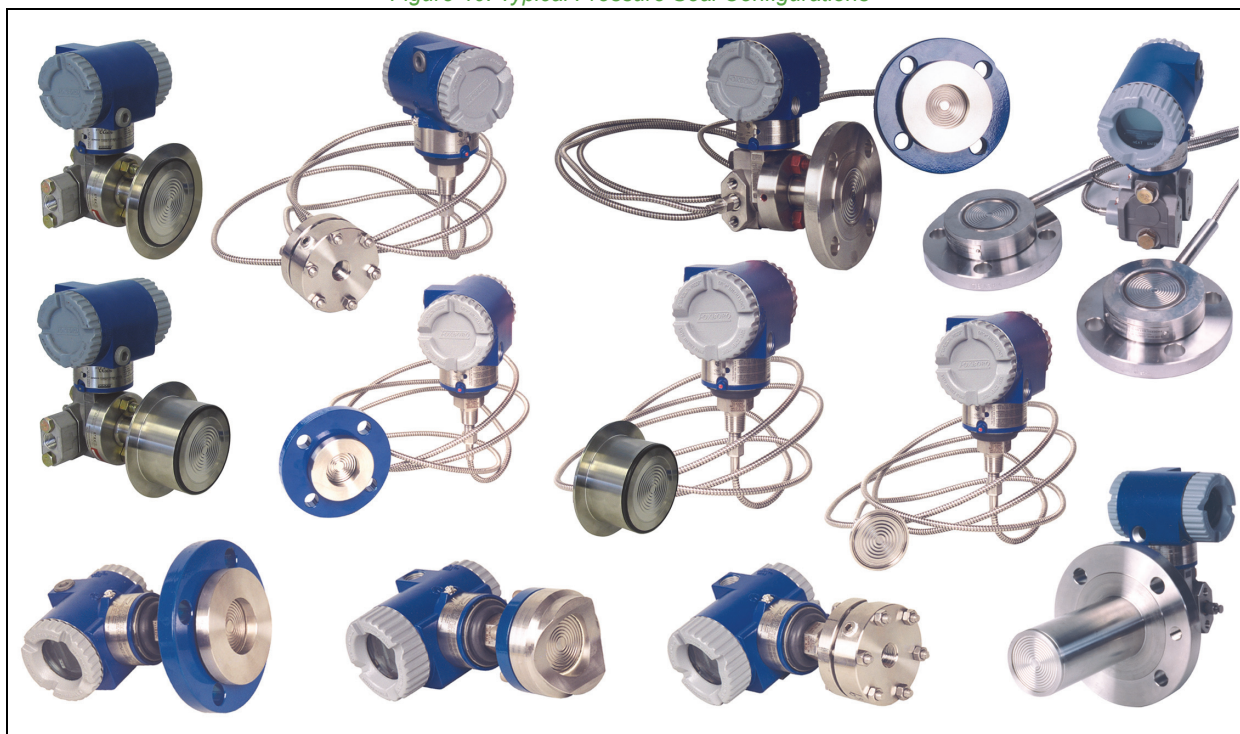

Table 4. Pressure Seals Used with I/A Series Pressure Transmitters

Direct Connect Pressure Seal Assemblies		
Seal Model	Seal Description	Process Connections
PSFLT	Flanged, Direct Connect (Flanged Level), Flush or Extended Diaphragm	ANSI Class 150/300/600 flanges and BS/DIN PN 10/40, 10/16, 25/40 flanges
PSFAD	Flanged, Direct Connect, Recessed Diaphragm	ANSI Class 150, 300, 600, 1500 flanges
PSFFD	Flanged, Direct Connect, Flush Diaphragm	ANSI Class 150/300/600 and PN 10/40
PSTAD	Threaded, Direct Connect, Recessed Diaphragm	1/4, 1/2, 3/4, 1, or 1 1/2 NPT internal thread
PSISD	In-Line Saddle Weld, Direct Connect, Recessed Diaphragm	Lower housing of seal is in-line saddle welded to nominal 3- or 4-inch (and larger) Pipe
PSSCT	Sanitary, Direct Connect (Level Seal), Flush Diaphragm	Process Connection to Sanitary Piping with 2- or 3-inch Tri-Clamp
PSSST	Sanitary, Direct Connect (Level Seal), Extended Diaphragm	Process Connection to 2-in Mini Spud or 4-in Standard Spud; Tri-Clamp
Remote Mount, Capillary-Connected Pressure Seal Assemblies		
PSFPS	Flanged, Remote Mount, Flush Diaphragm	ANSI Class 150/300/600 flanges and BS/DIN PN 10/40 flanges
PSFES	Flanged, Remote Mount, Extended Diaphragm	ANSI Class 150/300/600 flanges and BS/DIN PN 10/40, 10/16, 25/40 flanges



**Table 4. Pressure Seals Used with I/A Series Pressure Transmitters (Continued)**

Direct Connect Pressure Seal Assemblies		
Seal Model	Seal Description	Process Connections
PSFAR	Flanged, Remote Mount, Recessed Diaphragm	ANSI Class 150/300/600/1500 flanges
PSFFR	Flanged, Remote Mount, Flush Diaphragm	ANSI Class 150/300/600 and PN 10/40
PSTAR	Threaded, Remote Mount, Recessed Diaphragm	1/4, 1/2, 3/4, 1, or 1 1/2 NPT internal thread
PSISR	In-Line Saddle Weld, Remote Mount, Recessed Diaphragm	Lower housing of seal is in-line saddle welded to nominal 3- or 4-inch (and larger) Pipe
PSSCR	Sanitary, Remote Mount, Flush Diaphragm	Process Connection secured with a Tri-Clamp to a 2- or 3-inch pipe
PSSSR	Sanitary, Remote Mount, Extended Diaphragm	Process Connection to 2-in Mini Spud or 4-in Standard Spud; Tri-Clamp

**Table 5. I/A Series Pressure Transmitters and Applicable Pressure Seals**

Transmitter Model	Used with Pressure Seal Model: (a)													
	FLT	FAD	FFD	TAD	ISD	SCT	SST	FPS	FES	FAR	TAR	ISR	SCR	SSR
IAP10/IAP10S	-	✓	✓	✓	✓	-	-	✓	✓	✓	✓	✓	✓	✓
IAP20	-	-	-	-	-	-	-	✓	✓	✓	✓	✓	✓	✓
IGP10/IGP10S	-	✓	✓	✓	✓	-	-	✓	✓	✓	✓	✓	✓	✓
IGP20	✓	-	-	-	-	✓	✓	✓	✓	✓	✓	✓	✓	✓
IGP25	-	✓	✓	✓	✓	-	-	✓	✓	✓	✓	✓	✓	✓
IGP50	-	-	-	-	-	-	-	-	-	-	-	-	-	-
IDP10/IDP10S	✓	-	-	-	-	✓	✓	✓	✓	✓	✓	✓	✓	✓
IDP25	✓	-	-	-	-	✓	✓	✓	✓	✓	✓	✓	✓	✓
IDP50, IMV25, IMV30, and IMV31; Not Applicable - Contact Invensys.														

a. Pressure Seal models are shown with an abbreviated code; all seal codes have a PS prefix; for example, FLT is really Model PSFLT.



TRANSMITTERS WITH INTEGRAL CONNECTORS FOR SANITARY PROCESSES

IAP10, IGP10, and IGP25 Transmitters are offered with integral sanitary process connections. They include a Tri-Clamp type connector, mini tank spud, extended mini tank spud, and threaded spud type connectors. The transmitters are characterized with the process connection for improved performance. Neobee M-20 fill fluid is used, and industry standard 316L ss is offered for process connection and sensor wetted parts. These instruments conform to 3-A sanitary standards. See figures below and Tables 6, 7, 8.

TRANSMITTER WITH INTEGRAL  
SANITARY TRI-CLAMP TYPE  
PROCESS CONNECTOR

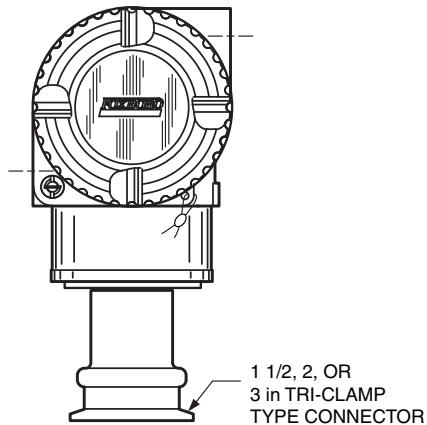

TRANSMITTER WITH INTEGRAL  
MINI TANK SPUD SEAL  
TRI-CLAMP TYPE CONNECTOR

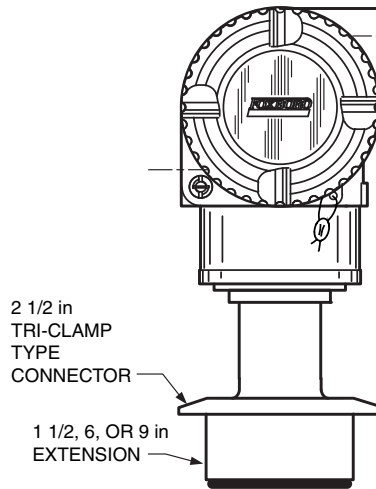

TRANSMITTER WITH INTEGRAL  
THREADED, SPUD TYPE  
PROCESS CONNECTOR

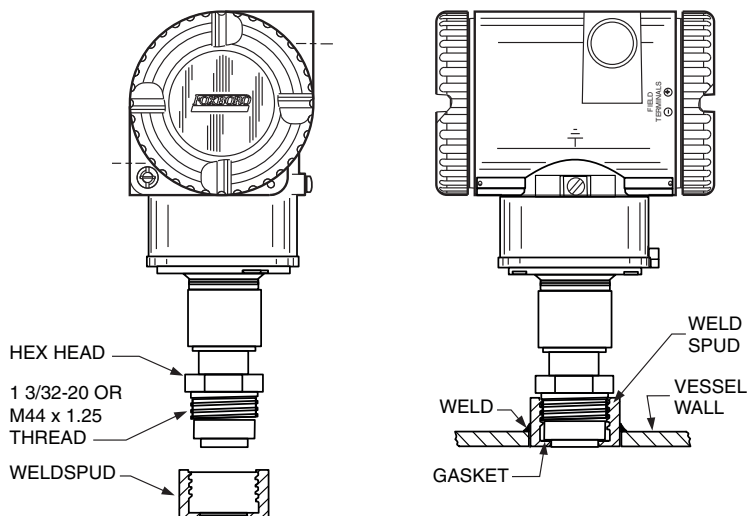

**Accessories**

Numerous accessories are offered for use with the IAP10, IGP10, and IGP25 Transmitters with integral sanitary process connectors. See Tables 6, 7, and 8 for part numbers, descriptions, and configurations.

**Table 6. Sanitary Process Connector Accessories -  
Weld Spuds, Heat Sink/Plugs, Calibration Adapters, and O-Rings/Gaskets (a)**

Accessory Description	Used with Structure Code	Part Number
For use with Mini Tank Spud Connector Weld Spud, 1.5-inch Extension supplied by User Weld Spud, 6-inch Extension supplied by User Weld Spud, 9-inch Extension supplied by User O-Rings	M1 M6 M9 M1, M6, M9	N1212GG N1214BP N1214BQ N1212LB (b)
For use with 1-inch Flush, Threaded Connector Weld Spud supplied by User (c) Heat Sink/Plug supplied by User (c) Calibration Adapter supplied by User Gasket (Gylon)	PX PX PX PX	N1214XW N1214YS N1214XX N1212YX
For use with 1.5-inch Flush, Threaded Connector Weld Spud (c) Heat Sink/Plug (c) Calibration Adapter Gasket (Gylon)	PZ PZ PZ PZ	N1214LG N1214YR N1214MN N1212YV

- a. Accessories are ordered and supplied separately.
- b. Part number is for a package of five O-rings or gaskets. Each transmitter is shipped with its required gaskets or O-rings. This package of gaskets/O-rings is recommended extras or spares.
- c. When ordering a weld spud with a threaded type connector, note that use of a heat sink/plug is required to prevent metal distortion due to the high temperature of the welding process.

**Table 7. Sanitary Process Connector Accessories -  
Tri-Clamps Supplied by User but can also be Ordered from Invensys**

Nominal Tube O.D.	MWP at 70°F	MWP at 250°F	Part Number
1.5 in Tube	500 psi	300 psi	N1212DA
2 in Tube	450 psi	300 psi	N1212DB
3 in Tube	350 psi	195 psi	N1212DC
1.5 in Tube	600 psi	300 psi	N1212PP
2 in Tube	550 psi	275 psi	N1212PQ
2.5 in Tube (a)	450 psi	225 psi	N1212HG (a)
3 in Tube	350 psi	175 psi	N1212PR
4 in Tube	300 psi	150 psi	N1212PS
1.5 in Tube	1500 psi	1200 psi	N1212FV
2 in Tube	1000 psi	800 psi	N1212FW
4 in Tube	800 psi	600psi	N1212AW

- a. The N1212HG connector for a 2.5 in Tube is used with Mini Tank Spud connectors M1, M6, and M9, and is supplied by Invensys.

Table 8. Sanitary Process Connector Accessories - Configuration of Weld Spuds, Heat Sink/Plugs, and Calibration Adapter

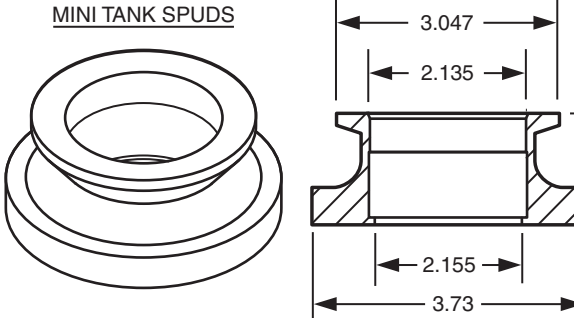
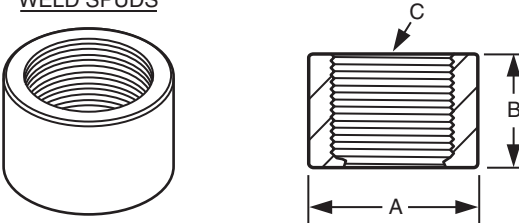
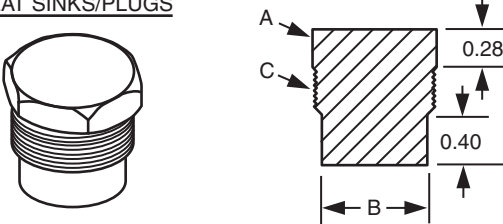
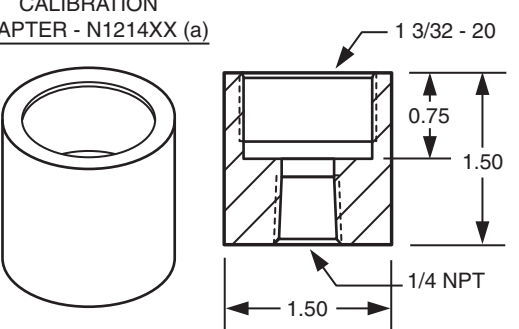
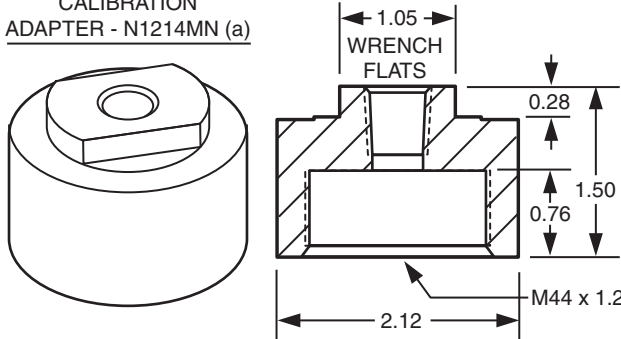
<p><b>MINI TANK SPUDS</b></p> 	<table border="1"> <thead> <tr> <th>Part No.</th> <th>Spud Extension A</th> <th>Structure Code</th> </tr> </thead> <tbody> <tr> <td>N1212GG</td> <td>1.50</td> <td>M1</td> </tr> <tr> <td>N1214BP</td> <td>6.00</td> <td>M6</td> </tr> <tr> <td>N1214BQ</td> <td>9.00</td> <td>M9</td> </tr> </tbody> </table>	Part No.	Spud Extension A	Structure Code	N1212GG	1.50	M1	N1214BP	6.00	M6	N1214BQ	9.00	M9			
Part No.	Spud Extension A	Structure Code														
N1212GG	1.50	M1														
N1214BP	6.00	M6														
N1214BQ	9.00	M9														
<p><b>WELD SPUDS</b></p> 	<table border="1"> <thead> <tr> <th>Part No. (a)</th> <th>A</th> <th>B</th> <th>Thread C</th> <th>Structure Code</th> </tr> </thead> <tbody> <tr> <td>N1214XW</td> <td>1.50</td> <td>0.80</td> <td>1 3/32-20</td> <td>PX</td> </tr> <tr> <td>N1214LG</td> <td>2.12</td> <td>0.80</td> <td>M44 x 1.25</td> <td>PZ</td> </tr> </tbody> </table> <p>a. Must be used with heat sinks/plugs below to prevent metal distortion due to high temperature of welding process.</p>	Part No. (a)	A	B	Thread C	Structure Code	N1214XW	1.50	0.80	1 3/32-20	PX	N1214LG	2.12	0.80	M44 x 1.25	PZ
Part No. (a)	A	B	Thread C	Structure Code												
N1214XW	1.50	0.80	1 3/32-20	PX												
N1214LG	2.12	0.80	M44 x 1.25	PZ												
<p><b>HEAT SINKS/PLUGS</b></p> 	<table border="1"> <thead> <tr> <th>Part No. (a)</th> <th>Hex Hd A</th> <th>Diameter B</th> <th>Thread C</th> <th>Structure Code</th> </tr> </thead> <tbody> <tr> <td>N1214YS</td> <td>1.125</td> <td>1.000</td> <td>1 3/32 - 20</td> <td>PX</td> </tr> <tr> <td>N1214YR</td> <td>1.75</td> <td>1.595</td> <td>M44 x 1.25</td> <td>PZ</td> </tr> </tbody> </table> <p>a. Must be used with weld spuds above to prevent distortion due to high temperature of welding process.</p>	Part No. (a)	Hex Hd A	Diameter B	Thread C	Structure Code	N1214YS	1.125	1.000	1 3/32 - 20	PX	N1214YR	1.75	1.595	M44 x 1.25	PZ
Part No. (a)	Hex Hd A	Diameter B	Thread C	Structure Code												
N1214YS	1.125	1.000	1 3/32 - 20	PX												
N1214YR	1.75	1.595	M44 x 1.25	PZ												
<p><b>CALIBRATION ADAPTER - N1214XX (a)</b></p>  <p>(a) Used with Structure Code PX.</p>	<p><b>CALIBRATION ADAPTER - N1214MN (a)</b></p>  <p>(a) Used with Structure Code PZ.</p>															

**TRANSMITTERS WITH INTEGRAL CONNECTORS FOR PULP AND PAPER PROCESSES**

*IAP10, IGP10, and IGP25 Gauge Pressure Transmitters are offered with integral connectors for pulp and paper processes. They include 1 and 1 1/2 inch sleeve and threaded type connectors; also a 1 1/2 inch threaded type connector to fit an Ametek spud. The transmitters are characterized with the integral process connector for improved performance. Diaphragm materials are either 316L ss or Hastelloy C, and the fill fluid is silicone. See figures below and the Accessories tables that follow.*

TRANSMITTER WITH INTEGRAL PULP AND PAPER THREADED TYPE CONNECTOR

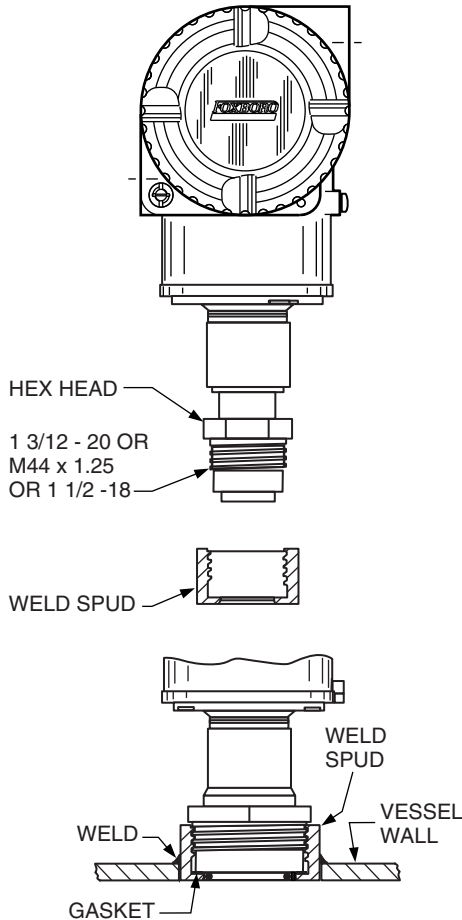

TRANSMITTER WITH INTEGRAL PULP AND PAPER SLEEVE TYPE CONNECTOR

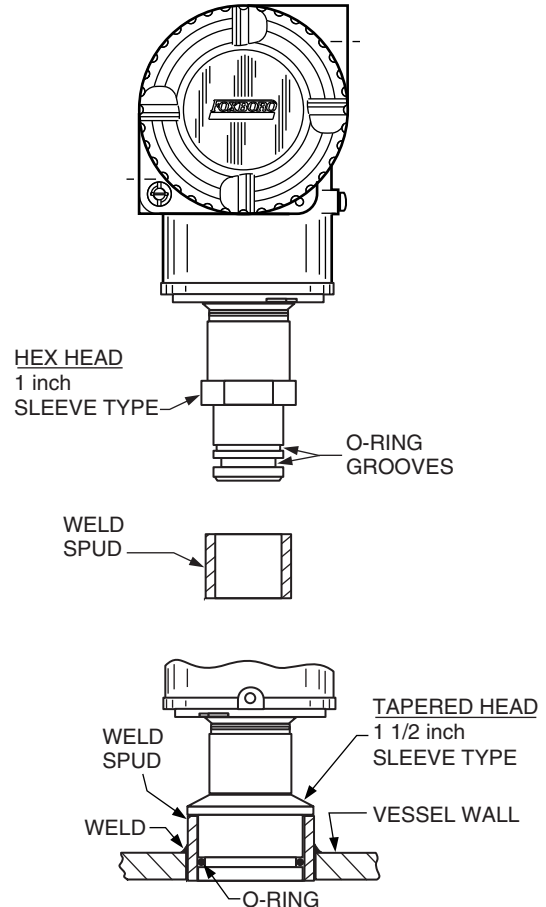

### Accessories

Numerous accessories are offered for use with the IGP10 and IGP25 Transmitters with integral connectors for the pulp and paper industry. See Tables 9 and 10 for part numbers, descriptions, and configurations of these accessories.

**Table 9. Weld Spuds, Calibration Adapters, Heat Sinks/Plugs, O-Rings, and Gaskets used with Threaded and Sleeve Type Process Connectors (a)**

Description of Accessory	Used with Structure Code	Part Number (b)
For use with 1-inch Sleeve Type Connector Weld Spud Calibration Adapter Process O-Ring at Diaphragm (Viton), 1-in Sleeve (c) Process O-Ring, Outer (Viton), 1-in Sleeve (d)	PA, PE PA, PE PA, PE PA, PE	N1214LH N1214MP N1214YY N1214YZ
For use with 1-inch Flush, Threaded Type Connector Weld Spud (d) Heat Sink/Plug (d) Calibration Adapter Process Gasket (Gylon) (d)	PB, PF PB, PF PB, PF PB, PF	N1214XW N1214YS N1214XX N1214YX
For use with 1.5-inch Sleeve Type Connector Weld Spud Calibration Adapter Process O-Ring (Viton) (c)	PC, PG PC, PG PC, PG	N1214MM N1214MQ N1214YW
For use with 1.5-inch Flush, Threaded Type Connector Weld Spud (d) Heat Sink/Plug (d) Calibration Adapter Process Gasket (Gylon) (c)	PD, PH PD, PH PD, PH PD, PH	N1214LG N1214YR N1214MN N1214YV
For use with 1.5-inch Threaded Type Connector for Ametek Spud Weld Spud (d) Heat Sink/Plug (d) Calibration Adapter Process Gasket (Gylon) (c)	PJ PJ PJ PJ	N1216AM N1216AP N1216AN N1216AQ

- Accessories are ordered and supplied separately.
- Refer to Table 10 for configuration and dimensions of certain accessories listed.
- Each transmitter is shipped with its required gaskets or O-rings. The gaskets and O-rings listed are offered as extras (spares).
- When ordering a weld spud for use with a threaded type connector, note that use of a heat sink/plug is required to prevent metal distortion due to the high temperature of the welding process.

Table 10. Pulp and Paper Accessories - Configuration of Weld Spuds, Heat Sinks/Plugs, and Calibration Adaptors

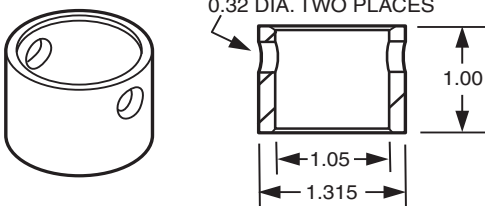
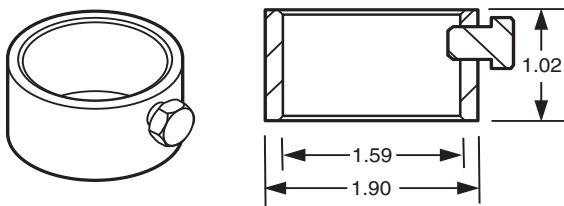
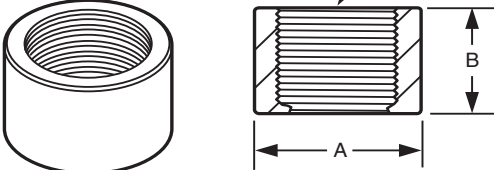
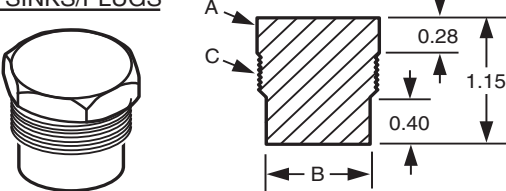
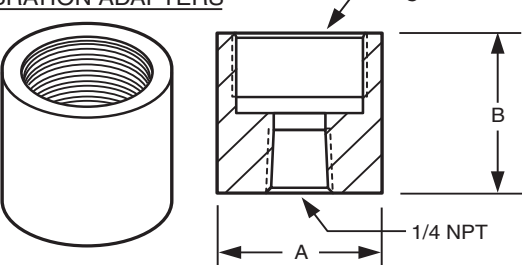
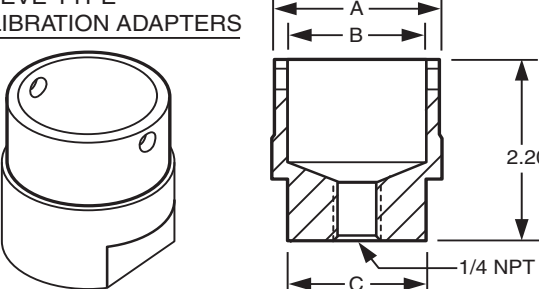
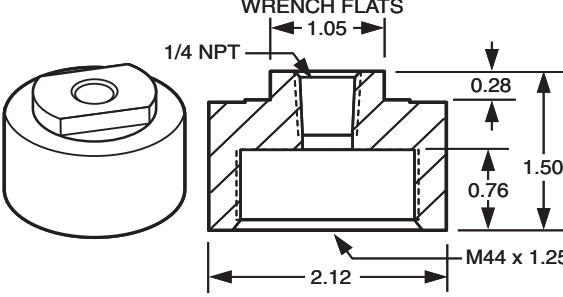
<p><b>WELD SPUD - N1214LH (a)</b></p>  <p>(a) Used with Structure Codes PA, PE</p>	<p><b>WELD SPUD - N1214MM (a)</b></p>  <p>(a) Used with Structure Codes PC, PG</p>																				
<p><b>WELD SPUDS</b></p> 	<table border="1"> <thead> <tr> <th>Part No. (a)</th> <th>A</th> <th>B</th> <th>Thread C</th> <th>Struct. Code</th> </tr> </thead> <tbody> <tr> <td>N1214XW</td> <td>1.50</td> <td>0.80</td> <td>1 3/32-20</td> <td>PB, PF</td> </tr> <tr> <td>N1214LG</td> <td>2.12</td> <td>0.80</td> <td>M44 x 1.25</td> <td>PD, PH</td> </tr> <tr> <td>N1216AM</td> <td>1.99</td> <td>1.00</td> <td>1 1/2-18</td> <td>PJ</td> </tr> </tbody> </table> <p>a. Must be used with heat sinks/plugs below to prevent metal distortion due to high temperature of welding process.</p>	Part No. (a)	A	B	Thread C	Struct. Code	N1214XW	1.50	0.80	1 3/32-20	PB, PF	N1214LG	2.12	0.80	M44 x 1.25	PD, PH	N1216AM	1.99	1.00	1 1/2-18	PJ
Part No. (a)	A	B	Thread C	Struct. Code																	
N1214XW	1.50	0.80	1 3/32-20	PB, PF																	
N1214LG	2.12	0.80	M44 x 1.25	PD, PH																	
N1216AM	1.99	1.00	1 1/2-18	PJ																	
<p><b>HEAT SINKS/PLUGS</b></p> 	<table border="1"> <thead> <tr> <th>Part No. (a)</th> <th>A</th> <th>B</th> <th>Thread C</th> <th>Struct. Code</th> </tr> </thead> <tbody> <tr> <td>N1214YS</td> <td>1.125</td> <td>1.000</td> <td>1 3/32 - 20</td> <td>PB, PF</td> </tr> <tr> <td>N1214YR</td> <td>1.75</td> <td>1.595</td> <td>M44 x 1.25</td> <td>PD, PH</td> </tr> <tr> <td>N1216AP</td> <td>1.75</td> <td>1.595</td> <td>1 1/2-18</td> <td>PJ</td> </tr> </tbody> </table> <p>a. Must be used with weld spuds above to prevent metal distortion due to high temperature of welding process.</p>	Part No. (a)	A	B	Thread C	Struct. Code	N1214YS	1.125	1.000	1 3/32 - 20	PB, PF	N1214YR	1.75	1.595	M44 x 1.25	PD, PH	N1216AP	1.75	1.595	1 1/2-18	PJ
Part No. (a)	A	B	Thread C	Struct. Code																	
N1214YS	1.125	1.000	1 3/32 - 20	PB, PF																	
N1214YR	1.75	1.595	M44 x 1.25	PD, PH																	
N1216AP	1.75	1.595	1 1/2-18	PJ																	
<p><b>THREADED-TYPE CALIBRATION ADAPTERS</b></p> 	<table border="1"> <thead> <tr> <th>Part No.</th> <th>A</th> <th>B</th> <th>Thread C</th> <th>Struct. Code</th> </tr> </thead> <tbody> <tr> <td>N1214XX</td> <td>1.50</td> <td>1.50</td> <td>1 3/32-20</td> <td>PB, PF</td> </tr> <tr> <td>N1216AN (a)</td> <td>1.99</td> <td>1.75</td> <td>1 1/2-18</td> <td>PJ</td> </tr> </tbody> </table> <p>a. For Ametek spud.</p>	Part No.	A	B	Thread C	Struct. Code	N1214XX	1.50	1.50	1 3/32-20	PB, PF	N1216AN (a)	1.99	1.75	1 1/2-18	PJ					
Part No.	A	B	Thread C	Struct. Code																	
N1214XX	1.50	1.50	1 3/32-20	PB, PF																	
N1216AN (a)	1.99	1.75	1 1/2-18	PJ																	
<p><b>SLEEVE-TYPE CALIBRATION ADAPTERS</b></p>  <table border="1"> <thead> <tr> <th>Part No.</th> <th>A</th> <th>B</th> <th>C</th> <th>Struct. Code</th> </tr> </thead> <tbody> <tr> <td>N1214MG</td> <td>1.90</td> <td>1.60</td> <td>1.62</td> <td>PA, PE</td> </tr> <tr> <td>N1216MP</td> <td>1.315</td> <td>1.05</td> <td>1.05</td> <td>PC, PG</td> </tr> </tbody> </table>	Part No.	A	B	C	Struct. Code	N1214MG	1.90	1.60	1.62	PA, PE	N1216MP	1.315	1.05	1.05	PC, PG	<p><b>THREADED-TYPE CALIBRATION ADAPTER - N1214MN (a)</b></p>  <p>(a) Used with Structure Codes PD, PH</p>					
Part No.	A	B	C	Struct. Code																	
N1214MG	1.90	1.60	1.62	PA, PE																	
N1216MP	1.315	1.05	1.05	PC, PG																	

## TRANSMITTERS WITH 1-, 2-, 3-, AND 5-VALVE MANIFOLDS

### Description

Manifolds are compact devices that easily and economically isolate the transmitter from the process to conveniently allow venting, calibration, and maintenance of the transmitter (without shutting down the process). See Table 11 for manifolds offered.

1- and 2-valve manifolds are offered for threading to a direct connect absolute or gauge pressure transmitter, and are available in a standard or commodity version configuration. The 1-valve manifold (Manifold Model M9) is also available as Block and Bleed Valve Option -V2 (carbon steel), or Option -V3 (316 ss), or Option -V4 (316 ss with Monel trim).

2-, 3-, and 5-valve manifolds are offered for attaching to a bracket mounted absolute or gauge pressure transmitter with a traditional structure, or to a bracket mounted d/p Cell transmitter with either a traditional or low profile structure. They are also available in a standard or commodity version configuration.

Mounting brackets are also offered with many of the manifold/transmitter assemblies (other than commodity version manifolds). A bracket attaches to the manifold, and the manifold attaches to the transmitter (manifold between transmitter and bracket). See figure below for typical assemblies.

See Table 12 for manifolds available with this pressure transmitter family. Also see PSS 2B-1Z2 A for detailed descriptions and specifications.

### Standard Version Manifolds available for use with Traditional and Low Profile Transmitter Structures

Standard version manifolds are offered for use with direct-connect or bracket mounted absolute and gauge pressure transmitters, and for d/p Cell transmitters all having a traditional structure. This traditional structure is the commonly used right angle design, where the process connections are oriented 90 degrees from the transmitter centerline. This traditional transmitter structure allows easy retrofitting of any transmitter of similar design.

Standard version manifolds are also offered for d/p Cell transmitters having a low profile structure that uses an in-line design. The in-line design places the transmitter process connections in line with the transmitter centerline. This transmitter configuration provides a style similar to competitive Coplanar™ transmitters. The low profile transmitter is offered in either an LP1 or LP2 configuration, either of which is usable with the applicable manifold. See Table 12.

### Commodity Version Manifolds also Offered

In addition to the standard version manifolds, commodity versions are also available. These are low cost manifolds having either a 1-, 2-, 3-, or 5-valve configuration. They are offered for use with direct connect absolute and gauge pressure transmitters, bracket mounted absolute and gauge pressure transmitters, and d/p Cell transmitters all having a traditional structure. They are not offered with low profile structures. See Table 12.

### Manifold Options

The -H1 and -H2 are manifold attachments to the transmitters. They are available for IAP, IGP, IDP and IMV transmitters. They are not offered with remote seals or closed coupled seals.

Model Code Suffix	Description
-H1	Factory attaches the manifold to the transmitter and conducts a leak test.
-H2	Factory attaches the manifold to the transmitter, conducts a leak test, and provides a Pressure Certification of the leak test.



Figure 41. Typical 1-, 2-, 3-, and 5-Valve Manifold/Transmitter Assemblies with AGCO Mounting Bracket, as applicable



Table 11. 1-, 2-, 3-, and 5-Valve Manifold Descriptions

Model	No. of Valves	Version/ Struct.	Connection to Process	Options (a)	Application		
					General Purpose	Natural Gas	Power Service
M9 (b)	1	Commodity	1/2 - 14 NPT	-SG, -SG3	X	–	–
PTM	2	Commodity	1/2 - 14 NPT	-SG, -SG3	X	–	–
MX2T	2	Com./Trad.	1/2 - 14 NPT	-SG	X	–	–
PT7	2	Standard	1/2 - 14 NPT	-AM, -SG, -SG3, -OC	X	–	–
PT7M	2	Standard	1/2 - 14 NPT	-AM, -XP, -OC	–	–	X
M25-VI	2	Standard	1/2 - 14 NPT	-AM, -SG, -SG3, -OC	X	–	–
M25-HI	2	Standard	1/2 - 14 NPT	-AM, -SG, -SG3, -OC	X	–	–
M25-HP	2	Standard	1/2 - 14 NPT	-AM	–	–	X
M4AP	2	Std./Trad.	Flanged	-AM, -SG, -SG3, -OC	X	–	–
M4TP	2	Std./Trad.	1/2 - 14 NPT	-AM, -SG, -SG3, -OC	X	–	–
MX3T	3	Com./Trad.	1/2 - 14 NPT	-SG	X	–	–
M4A	3	Std./Trad.	Flanged	-AM, -SG, -SG3, -OC	X	–	–
M4T	3	Std./Trad.	1/2 - 14 NPT	-AM, -SG, -SG3, -OC	X	–	–
MB3-VI	3	Std./Lo-Pro.	1/2 - 14 NPT	-AM, -SG, -SG3, -OC	X	–	–
MB3-HI	3	Std./Lo-Pro.	1/2 - 14 NPT	-AM, -SG, -SG3, -OC	X	–	–
MB3-HP	3	Std./Lo-Pro.	1/2 - 14 NPT	-AM	–	–	X

Table 11. 1-, 2-, 3-, and 5-Valve Manifold Descriptions (Continued)

Model	No. of Valves	Version/ Struct.	Connection to Process	Options (a)	Application		
					General Purpose	Natural Gas	Power Service
MM5G	5	Com./Trad.	1/2 - 14 NPT	-SG	X	X	–
MM5P	5	Com./Trad.	1/2 - 14 NPT	-SG	X	–	–
M6TA	5	Std./Trad.	Flanged	-AM, -SG, -OC	X	X	–
M6T	5	Std./Trad.	1/2 - 14 NPT	-AM, -SG, -OC	X	X	–
MB5G	5	Std./Lo-Pro.	1/2 - 14 NPT	-AM, -SG, -SG3, -OC	X	X	–
MB5P-VI	5	Std./Lo-Pro.	1/2 - 14 NPT	-AM, -SG, -SG3, -OC	X	–	–
MB5P-HI	5	Std./Lo-Pro.	1/2 - 14 NPT	-AM, -SG, -SG3, -OC	X	–	–
MB5P-HP	5	Std./Lo-Pro.	1/2 - 14 NPT	-AM	–	–	X
M24A	5	Std./Trad.	Flanged	-AM, -SG, -SG3, -OC	X	–	–
M24T	5	Std./Trad.	1/2 - 14 NPT	-AM, -SG, -SG3, -OC	X	–	–

a. Optional Selections offered are:

-AM = AGCO Mounting Kit for mounting manifold to 2-inch pipe stand.

-OC = Clean for Oxygen Service.

-SG = Sour Gas Applications - stainless steel body only.

-SG3 = Sour Gas Applications - Nickel alloy (equivalent to Hastelloy®-C -276) body only.

b. The Model M9 Manifold (Block and Bleed Valve) is also available as Transmitter Options -V2, -V3, and -V4. See Table 13.

Table 12. Compatibility of Manifolds with the I/A Series Electronic Pressure Transmitter Family and also the Pneumatic d/p Cell Transmitter Family

Transmitter Description		Manifold Models with Transmitter Structures			
Model	Transmitter Mounting and Measurement (a)	Commodity Version with Direct Conn. Transmitters	Commodity Version with Traditional Structure	Standard Version with Traditional Structure	Standard Version with Low Profile Structure
<b>I/A Series Electronic Transmitter Family</b>					
IAP10/IAP10S	Direct Connect; AP	1-Valve: M9 2-Valve: PTM	Not Applicable	2-Valve: M25-VI M25-HI M25-HP PT7 PT7M	Not Applicable
IGP10/IGP10S	Direct Connect; GP				
IGP25	Direct Connect/Multirange; GP				
IGP50	Direct Connect/ Premium Performance; GP				
IAP20	Bracket Mounted; AP	Not Applicable	2-Valve: MX2T	2-Valve: M4AP M4TP	Not Applicable
IGP20	Bracket Mounted; GP				

Table 12. Compatibility of Manifolds with the I/A Series Electronic Pressure Transmitter Family and also the Pneumatic d/p Cell Transmitter Family (Continued)

Transmitter Description		Manifold Models with Transmitter Structures			
Model	Transmitter Mounting and Measurement (a)	Commodity Version with Direct Conn. Transmitters	Commodity Version with Traditional Structure	Standard Version with Traditional Structure	Standard Version with Low Profile Structure
<b>I/A Series Electronic Transmitter Family</b>					
IDP10/IDP10S	Bracket Mounted; DP	Not Applicable	3-Valve: MX3T 5-Valve: MM5G MM5P	3-Valve: M4A M4T 5-Valve: M6TA M6T M24A M24T	3-Valve: MB3-VI MB3-HI MB3-HP 5-Valve: MB5G MB5P-VI MB5P-HI MB5P-HP
IDP25	Bracket Mounted/Multirange; DP				
IDP50	Bracket Mounted/ Premium Performance; DP				
IMV25	Bracket Mounted/Multivariable; Flow Measurement	Not Applicable	3-Valve: MX3T 5-Valve MM5G MM5P	3-Valve: M4A M4T 5-Valve: M6TA M6T M24A M24T	Not Applicable
IMV30	Bracket Mounted/Multivariable; Flow Measurement				
IMV31	Bracket Mounted/Multivariable; Level Measurement				
<b>Pneumatic d/p Cell Transmitter Family</b>					
13A	Bracket Mounted - DP	Not Applicable	3-Valve: MX3T 5-Valve MM5G MM5P	3-Valve: M4A M4T 5-Valve: M6TA M6T M24A M24T	Not Applicable
13HA	Bracket Mounted - DP				
15A	Bracket Mounted - DP				

a. AP=Absolute Pressure; GP=Gauge Pressure; DP=Differential Pressure; also see Table 1.

OPTIONS SELECTABLE FROM TRANSMITTER MODEL CODE

Table 13. Direct Connect AP and GP Transmitters

	Option Description	Model Code Option Suffix	Available with Transmitter Model (a)						Comments
			IAP10	IAP10S	IGP10	IGP10S	IGP25	IGP50	
Conduit Thread Adapters	Hawke-Type 1/2 NPT Cable Gland	-A1	Yes	Yes	Yes	Yes	Yes	Yes	—
	Plastic PG 13.5 Cable Gland	-A2	Yes	No	Yes	No	Yes	Yes	—
	M20 Conduit Thread Adaptor	-A3	Yes	Yes	Yes	Yes	Yes	Yes	1/2 NPT to M20 Adapter.
	Brass PG 13.5 Cable Gland	-A4	Yes	No	Yes	No	Yes	Yes	Trumpet-Shaped wire entry.
Custom Factory Calibration and Configuration	Digital Output Configuration	-C1	Yes	No	Yes	No	Yes	Yes	Available with FoxCom for previous transmitters.
	Custom Factory Calibration	-C1	No	Yes	No	Yes	No	No	—
	Custom Factory Configuration	-C2	Yes	No	Yes	No	Yes	Yes	User must fill out Data Form
	Full Factory Configuration	-C2	No	Yes	No	Yes	No	No	User must fill out Data Form
Manometer Connection	G 1/2 Form B external thread to manometer	-G	Yes	Yes	Yes	Yes	Yes	No	Also with IGP10 High Gauge Pressure Transmitters. See inside pages.
Process Connection	Autoclave F-250-C	-G1	No	No	Yes	No	No	No	With High Gauge Pressure Transmitters only. See inside pages.
	1/2 NPT external thread.	-G2	No	No	Yes	No	No	No	

Table 13. Direct Connect AP and GP Transmitters (Continued)

	Option Description	Model Code Option Suffix	Available with Transmitter Model (a)						Comments
			IAP10	IAP10S	IGP10	IGP10S	IGP25	IGP50	
Manifold Options	Factory attaches the manifold to the transmitter and conducts a leak test.	-H1	Yes	Yes	Yes	Yes	Yes	Yes	Not available with remote seals or closed coupled seals.
	Factory attaches the manifold to the transmitter, conducts a leak test, and provides a Pressure Certification of the leak test.	-H2	Yes	Yes	Yes	Yes	Yes	Yes	
Operating Temperature	Operating Temperature of Housing is extended down to -50°C (-58°F).	-J	Yes	No	Yes	No	Yes	Yes	Not available with Inert Fill in Sensor or Seal.
Transmitter Instructions	Brief "Getting Started" document is all that is provided.	-K1	Yes	Yes	Yes	Yes	Yes	Yes	Standard Transmitter shipped with Paper Manuals and full Instruction Set on DVD (no manual or DVD with Option -K1).
LCD Indicator	An Integral LCD Indicator with on-board Pushbuttons.	-L1	Yes	Yes	Yes	Yes	Yes	Yes	With Digital Output Transmitters only.
	Blind Cover replaces Glass Window Cover on electronics housing.	-L2	Yes	No	Yes	No	Yes	Yes	With Analog Output Transmitters only.

Table 13. Direct Connect AP and GP Transmitters (Continued)

	Option Description	Model Code Option Suffix	Available with Transmitter Model (a)						Comments
			IAP10	IAP10S	IGP10	IGP10S	IGP25	IGP50	
Mounting Bracket Set	cs Bracket, 1/2 NPT cs Bolts	-M1	Yes	Yes	Yes	Yes	Yes	Yes	The -M1 to -M8 mounting bracket attaches to the electronic housing.
	ss Bracket, 1/2 NPT ss Bolts	-M2	Yes	Yes	Yes	Yes	Yes	Yes	
	cs Bracket, PG 13.5 NPT cs Bolts	-M3	Yes	No	Yes	No	Yes	Yes	
	ss Bracket, PG 13.5 NPT ss Bolts	-M4	Yes	No	Yes	No	Yes	Yes	
	cs Bracket, M20 NPT cs Bolts	-M5	Yes	Yes	Yes	Yes	Yes	Yes	
	cs Bracket, M20 NPT ss Bolts	-M6	Yes	Yes	Yes	Yes	Yes	Yes	
	SS Bracket; Stainless Steel Bolts	-M7	No	Yes (b)	No	Yes (b)	No	No	
	Painted Steel Bracket; Plated Steel Bolts	-M8	No	Yes (b)	No	Yes (b)	No	No	
Process Connection	1/2 NPT to R 1/2 Adapter	-R	Yes	Yes	Yes	Yes	Yes	Yes	Not with Seals or Nickel Alloy (equivalent to Hastelloy®) Sensors.
SIL2 (Safety Integrity Level)	SIL2 Certified HART Transmitters	-S2	Yes	No	Yes	No	No	No	A copy of the certification is available via AS Code CERT-S.
Customer Tag	Supplemental tag. This is in addition to the standard tag.	-T	Yes	Yes	Yes	Yes	Yes	Yes	This stainless steel tag is attached to the transmitter with wire.
Vent Screw	In Process Connection; 316 ss Vent Screw.	-V1	Yes	Yes	Yes	Yes	Yes	No	Not available with pressure seals.
Block and Bleed Valve (c)	Carbon Steel	-V2	Yes	Yes	Yes	Yes	Yes	Yes	Block and Bleed Valves are not available with Pressure Seals.
	Stainless Steel	-V3	Yes	Yes	Yes	Yes	Yes	Yes	
	316 ss with Monel Trim	-V4	Yes	Yes	Yes	Yes	Yes	Yes	



Table 13. Direct Connect AP and GP Transmitters (Continued)

	Option Description	Model Code Option Suffix	Available with Transmitter Model (a)						Comments
			IAP10	IAP10S	IGP10	IGP10S	IGP25	IGP50	
Transmitter Warranty	Optional 17-year warranty is offered.	-W	No	No	No	No	Yes	Yes	Standard warranty is 5 years.
Transmitter Cleaning (Clean Room)	Special Degreasing	-X1	Yes	Yes	Yes	Yes	Yes	Yes	With Silicone Sensors only.
	Oxygen Service Cleaning	-X2	Yes	Yes	Yes	Yes	Yes	No	With Silicone Sensors only.
	Chlorine Service Cleaning	-X3	Yes	Yes	Yes	Yes	No	No	With Inert Sensors only.
Electronics Housing Features	External Zero Adjustment	-Z1	Yes	Yes	Yes	Yes	Yes	Yes	—
	Custody Transfer Lock and Seal	-Z2	Yes	Yes	Yes	Yes	Yes	Yes	—
	Both Extended Zero and Custody Transfer	-Z3	Yes	Yes	Yes	Yes	Yes	Yes	—

- a. See Tables 1 and 2 for Transmitter PSS numbers.
- b. Flameproof transmitters only.
- c. Also available as manifold Model M9; see MANIFOLDS section and PSS 2B-1Z2 A.

Table 14. Bracket Mounted AP and GP Transmitters

Option Description		Model Code Option Suffix	Available with Transmitter Model (a)		Comments
			IAP20	IGP20	
Conduit Thread Adapters	Hawke-Type 1/2 NPT Cable Gland	-A1	Yes	Yes	– – 1/2 NPT to M20 Adapter Trumpet-Shaped wire entrance
	Plastic PG 13.5 Cable Gland	-A2	Yes	Yes	
	M20 Conduit Thread Adaptor	-A3	Yes	Yes	
	Brass PG 13.5 Cable Gland	-A4	Yes	Yes	
Bolting for Process Covers/ Connectors	316 ss Bolts and Nuts	-B1	Yes	Yes	Nonprocess-Wetted Bolting. Option -B2 has standard pressure rating of 25 MPa (3625 psi). See inside pages for derated pressure ratings with Options -B1 and -B3.
	17-4 ss Bolts and Nuts	-B2	Yes	Yes	
	B7M Bolts and Nuts. NACE Class II	-B3	Yes	Yes	
Custom Configuration	Digital Output Configuration	-C1	Yes	Yes	Available with FoxCom only. User must fill out Data Form.
	Custom Factory Configuration	-C2	Yes	Yes	
DIN 19213 Construction (Process Covers)	Single Ended Cover, M10, B7 Bolting	-D1	Yes	Yes	Used only with Process Connector Code 0, and 316 ss Covers with no side vents. Options -D3 and -D7 have standard pressure rating of 25 MPa (3625 psi). See inside pages for derated pressure ratings with Options -D1, -D2, -D4, -D5, -D6, and -D8.
	Double Ended Cover, M10, B7 Bolting	-D2	Yes	Yes	
	Single Ended Cover, 7/16 in, B7 Bolting	-D3	Yes	Yes	
	Double Ended Cover 7/16 in, B7 Bolting	-D4	Yes	Yes	
	Single Ended Cover, 7/16 in, 316 ss Bolting	-D5	Yes	Yes	
	Double Ended Cover, 7/16 in, 316 ss Bolting	-D6	Yes	Yes	
	Single Ended Cover, 7/16 in, 17-4 ss Bolting	-D7	Yes	Yes	
	Double Ended Cover, 7/16 in, 17-4 ss Bolting	-D8	Yes	Yes	
Tubing Connectors	6 mm Tubing, 1/4 NPT, cs	-E1	Yes	Yes	Tubing connects to process connector.
	12 mm Tubing, 1/2 NPT, cs	-E2	Yes	Yes	
	6 mm Tubing, 1/4 NPT, ss	-E3	Yes	Yes	
	12 mm Tubing, 1/2 NPT, ss	-E4	Yes	Yes	
Manometer Connection	G 1/2 Form B external thread to manometer	-G	No	No	–
Metal Gasket	For Vacuum Service with Pressure Seals.	-G1	No	Yes	Metal gasket is standard with IAP20.
Manifold Options	Factory attaches the manifold to the transmitter and conducts a leak test.	-H1	Yes	Yes	Not available with remote seals or closed coupled seals.
	Factory attaches the manifold to the transmitter, conducts a leak test, and provides a Pressure Certification of the leak test.	-H2	Yes	Yes	
Operating Temperature	Operating Temperature of Housing is extended down to -50°C (-58°F).	-J	Yes	Yes	Not available with Fluorinert Fill in Sensor or Seal.

Table 14. Bracket Mounted AP and GP Transmitters (Continued)

Option Description		Model Code Option Suffix	Available with Transmitter Model (a)		Comments
			IAP20	IGP20	
Transmitter Instructions	Brief "Getting Started" document is all that is provided.	-K1	Yes	Yes	Paper Manual and Instructions on DVD-ROM are standard (no manual/DVD-ROM with Option -K1).
LCD Indicator	An Integral LCD Indicator with on-board Pushbuttons.	-L1	Yes	Yes	With Digital Output Transmitters only.
	Blind Cover replaces Glass Window Cover on electronics housing.	-L2	Yes	Yes	With Analog Output Transmitters only.
Mounting Bracket Set	cs Mounting Bracket Set	-M1	Yes	Yes	These mounting brackets attach to the transmitter bottomworks.
	ss Mounting Bracket Set	-M2	Yes	Yes	
	ss Universal Mounting Set	-M3	Yes	Yes	
SIL2 (Safety Integrity Level)	SIL Certified HART Transmitters	-S2	Yes	Yes	A copy of the certification is available via AS Code CERT-S.
Customer Tag	Supplemental tag. This is in addition to the standard tag.	-T	Yes	Yes	This stainless steel tag is attached to the transmitter with wire.
Vent Screw	In Side of Process Cover	-V	Yes	Yes	With ss Process Covers only.
Transmitter Cleaning (Clean Room)	Special Degreasing	-X1	Yes	Yes	With Silicone Sensors only.
	Oxygen Service Cleaning	-X2	Yes	Yes	With Silicone Sensors only.
	Chlorine Service Cleaning	-X3	Yes	Yes	With Inert Sensors only.
Electronics Housing Features	External Zero Adjustment	-Z1	Yes	Yes	–
	Custody Transfer Lock and Seal	-Z2	Yes	Yes	–
	Both Extended Zero and Custody Transfer	-Z3	Yes	Yes	–

a. See Tables 1 and 2 for Transmitter PSS numbers.

Table 15. Multivariable Pressure Transmitters

Option Description		Model Code Option Suffix	Available with Transmitter Model (a)			Comments
			IMV25	IMV30	IMV31	
Conduit Thread Adapters	Hawke-Type 1/2 NPT Cable Gland M20 Conduit Thread Adaptor	-A1 -A3	Yes Yes	Yes Yes	Yes Yes	– 1/2 NPT to M20 Adapter.
Bolting for Process Covers/ Connectors	316 ss Bolts and Nuts 17-4 ss Bolts and Nuts B7M Bolts and Nuts, NACE Class II	-B1 -B2 -B3	Yes Yes Yes	Yes Yes Yes	Yes Yes Yes	Nonprocess-Wetted Bolting. Option -B2 has standard pressure rating of 25 MPa (3625 psi). See inside pages for derated pressure ratings with Options -B1 and -B3.
Custom Factory Configuration	Digital Output Configuration Custom Factory Configuration	-C1 -C2	Yes Yes	Yes Yes	No Yes	Available with FoxCom only User must fill out C2 Wizard configuration file.
DIN 19213 Construction (Process Covers)	Single Ended Cover, M10, B7 Bolting Double Ended Cover, M10, B7 Bolting Single Ended Cover, 7/16 in, B7 Bolting Double Ended Cover 7/16 in, B7 Bolting Single Ended Cover, 7/16 in, 316 ss Bolting Double Ended Cover, 7/16 in, 316 ss Bolting Single Ended Cover, 7/16 in, 17-4 ss Bolting Double Ended Cover, 7/16 in, 17-4 ss Bolting	-D1 -D2 -D3 -D4 -D5 -D6 -D7 -D8	Yes Yes Yes Yes Yes Yes Yes Yes	Yes Yes Yes Yes Yes Yes Yes Yes	Yes Yes Yes Yes Yes Yes Yes Yes	Used only with Process Connector Code 0, and 316 ss Covers with no side vents. Options -D3 and -D7 have standard pressure rating of 25 MPa (3625 psi). See inside pages for derated pressure ratings with Options -D1, -D2, -D4, -D5, -D6, and -D8.
Tubing Connectors	6 mm Tubing, 1/4 NPT, ss 12 mm Tubing, 1/2 NPT, ss	-E3 -E4	Yes Yes	Yes Yes	Yes Yes	Tubing connects to process connector.
Manifold Options	Factory attaches the manifold to the transmitter and conducts a leak test.	-H1	Yes	Yes	Yes	Not available with remote seals or closed coupled seals.
	Factory attaches the manifold to the transmitter, conducts a leak test, and provides a Pressure Certification of the leak test.	-H2	Yes	Yes	Yes	
Operating Temperature	Operating Temperature of Housing is extended down to -50°C (-58°F).	-J	Yes	Yes	Yes	Not available with inert Fill in Sensor or Seal.

Table 15. Multivariable Pressure Transmitters (Continued)

Option Description		Model Code Option Suffix	Available with Transmitter Model (a)			Comments
			IMV25	IMV30	IMV31	
Transmitter Instructions	Brief "Getting Started" document is all that is provided.	-K1	Yes	Yes	Yes	Standard Transmitter shipped with Paper Manuals and full Instruction Set on DVD-ROM (no manual or DVD-ROM with Option -K1).
LCD Indicator	An Integral LCD Indicator with on-board Pushbuttons.	-L1	Yes	Yes	Yes	—
Mounting Bracket Set	cs Mounting Bracket Set	-M1	Yes	Yes	Yes	These mounting brackets attach to the transmitter bottomworks.
	ss Mounting Bracket Set	-M2	Yes	Yes	Yes	
	ss Universal Mounting Set	-M3	Yes	Yes	Yes	
Customer Tag	Supplemental tag. This is in addition to the standard tag.	-T	Yes	Yes	Yes	This stainless steel tag is attached to the transmitter with wire.
Vent Screw	Supply in Side of each Process Cover.	-V	Yes	Yes	Yes	Traditional structure only.
	Omit vent screw in Side of Process Covers.	-V1	Yes	No	No	Available with LP1 Low Profile Structure only.
Transmitter Cleaning (Clean Room)	Special Degreasing	-X1	Yes	Yes	Yes	With Silicone Sensors only. With Silicone Sensors only. With Inert Sensors only.
	Oxygen Service Cleaning	-X2	Yes	Yes	Yes	
	Chlorine Service Cleaning	-X3	Yes	Yes	Yes	
Static Pressure Rating	The Static Pressure rating is increased to 40 MPa (5800 psi)	-Y	Yes	Yes	Yes	Standard static pressure rating is 25 MPa (3625 psi).

a. See Tables 1 and 2 for Transmitter PSS numbers.

Table 16. Differential Pressure Transmitters

Option Description		Model Code Option Suffix	Available with Transmitter Model (a)				Comments
			IDP10	IDP10S	IDP25	IDP50	
Conduit Thread Adapters	Hawke-Type 1/2 NPT Cable Gland	-A1	Yes	Yes	Yes	Yes	–
	Plastic PG 13.5 Cable Gland	-A2	Yes	No	Yes	Yes	–
	M20 Conduit Thread Adaptor	-A3	Yes	Yes	Yes	Yes	1/2 NPT to M20 Adapter
	Brass PG 13.5 Cable Gland	-A4	Yes	No	Yes	Yes	Trumpet-Shaped wire entrance
Bolting for Process Covers/ Connectors	316 ss Bolts and Nuts	-B1	Yes	Yes	Yes	Yes	Nonprocess-Wetted Bolting. Option -B2 has standard pressure rating of 25 MPa (3625 psi). See inside pages for derated pressure ratings with Options -B1 and -B3.
	17-4 ss Bolts and Nuts	-B2	Yes	Yes	Yes	Yes	
	B7M Bolts and Nuts, NACE Class II	-B3	Yes	Yes	Yes	Yes	
Custom Factory Configuration	Digital Output Configuration	-C1	Yes	No	Yes	Yes	Available with FoxCom only.
	Custom Factory Calibration	-C1	No	Yes	No	No	–
	Custom/Full Factory Configuration	-C2	Yes	Yes	Yes	Yes	User must fill out Data Form.



Table 16. Differential Pressure Transmitters (Continued)

Option Description		Model Code Option Suffix	Available with Transmitter Model (a)				Comments
			IDP10	IDP10S	IDP25	IDP50	
DIN 19213 Construction (Process Covers)	Single Ended Cover, M10, B7 Bolting	-D1	Yes	Yes	Yes	Yes	Used only with Process Connector Code 0, and 316 ss Covers with no side vents. Options -D2 and -D7 have standard pressure rating of 25 MPa (3625 psi). See inside pages for derated pressure ratings with Options -D1, -D2, -D4, -D5, -D6, and -D8. Option -D9 has a pressure rating of 40 MPa (5800 psi).
	Double Ended Cover, M10, B7 Bolting	-D2	Yes	Yes	Yes	Yes	
	Single Ended Cover, 7/16 in, B7 Bolting	-D3	Yes	Yes	Yes	Yes	
	Double Ended Cover 7/16 in, B7 Bolting	-D4	Yes	Yes	Yes	Yes	
	Single Ended Cover, 7/16 in, 316 ss Bolting	-D5	Yes	Yes	Yes	Yes	
	Double Ended Cover, 7/16 in, 316 ss Bolting	-D6	Yes	Yes	Yes	Yes	
	Single Ended Cover, 7/16 in, 17-4 ss Bolting	-D7	Yes	Yes	Yes	Yes	
	Double Ended Cover, 7/16 in, 17-4 ss Bolting	-D8	Yes	Yes	Yes	Yes	
	Single Ended Cover, 7/16 in, 17-4 ss Bolting	-D9	Yes	Yes	Yes	Yes	
Tubing Connectors	6 mm Tubing, 1/4 NPT, cs	-E1	Yes	Yes	No	No	Tubing connects to process connector.
	12 mm Tubing, 1/2 NPT, cs	-E2	Yes	Yes	No	No	
	6 mm Tubing, 1/4 NPT, ss	-E3	Yes	Yes	Yes	Yes	
	12 mm Tubing, 1/2 NPT, ss	-E4	Yes	Yes	Yes	Yes	
Metal Gasket	For Vacuum Service with Pressure Seals.	-G1	Yes	Yes	Yes	Yes	Substitutes metal gasket for standard ptfе process cover gasket.
Vented Cover	Vented low side process cover.	-G2	No	No	No	Yes	Used for Gauge Pressure applications with transmitter traditional structure only.
Manifold Options	Factory attaches the manifold to the transmitter and conducts a leak test.	-H1	Yes	Yes	Yes	Yes	Not available with remote seals or closed coupled seals.
	Factory attaches the manifold to the transmitter, conducts a leak test, and provides a Pressure Certification of the leak test.	-H2	Yes	Yes	Yes	Yes	

Table 16. Differential Pressure Transmitters (Continued)

Option Description		Model Code Option Suffix	Available with Transmitter Model (a)				Comments
			IDP10	IDP10S	IDP25	IDP50	
Operating Temperature	Operating Temperature of Housing is extended down to -50°C (-58°F).	-J	Yes	No	Yes	Yes	Not available with Inert Fill in Sensor or Seal.
Transmitter Instructions	Brief "Getting Started" document is all that is provided.	-K1	Yes	Yes	Yes	Yes	Standard Transmitter shipped with Paper Manuals and full Instruction Set on DVD-ROM (no manual or DVD-ROM with Option -K1).
LCD Indicator	An Integral LCD Indicator with on-board Pushbuttons.	-L1	Yes	Yes	Yes	Yes	With Digital Output Transmitters only.
	Blind Cover replaces Glass Window Cover on electronics housing.	-L2	Yes	No	No	No	With Analog Output Transmitters only.
Mounting Bracket Set	cs Mounting Bracket Set	-M1	Yes	Yes	Yes	Yes	These mounting brackets attach to the transmitter bottomworks.
	ss Mounting Bracket Set	-M2	Yes	Yes	Yes	Yes	
	ss Universal Mounting Set	-M3	Yes	Yes	Yes	Yes	
SIL2 (Safety Integrity Level)	SIL Certified HART Transmitters	-S2	Yes	No	No	No	A copy of the certification is available via AS Code CERT-S.
Customer Tag	Supplemental tag. This is in addition to the standard tag.	-T	Yes	Yes	Yes	Yes	This stainless steel tag is attached to the transmitter with wire.
Vent Screw	Supply in Side of each Process Cover.	-V	Yes	Yes	Yes	Yes	Traditional structure only.
	Omit vent screw in Side of Process Covers.	-V1	Yes	Yes	Yes	Yes	Available with LP1 Low Profile Structure only.
Transmitter Cleaning (Clean Room)	Special Degreasing	-X1	Yes	Yes	Yes	Yes	With Silicone Sensors only. With Silicone Sensors only. With Fluorinert Sensors only.
	Oxygen Service Cleaning	-X2	Yes	Yes	Yes	Yes	
	Chlorine Service Cleaning	-X3	Yes	Yes	Yes	Yes	

Table 16. Differential Pressure Transmitters (Continued)

Option Description		Model Code Option Suffix	Available with Transmitter Model (a)				Comments
			IDP10	IDP10S	IDP25	IDP50	
Static Pressure Rating	The Static Pressure rating is increased to 40 MPa (5800 psi)	-Y	Yes	Yes	Yes	Yes	Standard static pressure rating is 25 MPa (3625 psi).
Electronics Housing Features	External Zero Adjustment Custody Transfer Lock and Seal Both Extended Zero and Custody Transfer	-Z1	Yes	Yes	Yes	Yes	–
		-Z2	Yes	Yes	Yes	Yes	–
		-Z3	Yes	Yes	Yes	Yes	–

a. See Tables 1 and 2 for Transmitter PSS numbers.

OPTIONS NOT SELECTABLE FROM TRANSMITTER MODEL CODE

Table 17. Accessories That Must be Ordered Separately

Accessory Description	AS Code Part No. PSS No.	Available with Transmitter Model										
		IAP10 IGP10	IAP10S IGP10S	IAP20 IGP20	IDP10	IDP10S	IGP25 IGP50	IDP25 IDP50	IMV25	IMV30	IMV31	
Configurators, Remote ▶ HART Communicator (-T, -F) ▶ Model HHT50 (-D, -T) ▶ Model PC20 (-D, -T) ▶ Model PC50 (-D, -T) ▶ Model PCMM (-M) ▶ Model PCMV (-D, -T)	Inside Pages	Yes	Yes	Yes	Yes	Yes	Yes	Yes	Yes	No	No	No
	PSS 2A-1Z3 L	Yes	No	Yes	Yes	No	Yes	Yes	No	No	No	Yes
	PSS 2A-1Z3 E	Yes	No	Yes	Yes	No	Yes	Yes	No	No	No	No
	PSS 2A-1Z3 G	Yes	Yes	Yes	Yes	Yes	Yes	Yes	No	No	No	Yes
	PSS 2A-1Z3 H	No	No	No	No	No	No	No	Yes	No	No	No
	PSS 2A-1Z3 F	No	No	No	No	No	No	No	Yes	Yes	No	No
NACE MR 01-75 Service; Material Compliance	AS MR-01	Yes	Yes	Yes	Yes	Yes	Yes	Yes	Yes	Yes	Yes	Yes
Calibration Screw; 0.7 MPa (100 psi)	P.N. F0101ES	Yes	Yes	Yes	Yes	Yes	Yes	Yes	Yes	Yes	Yes	Yes
Certificates, Quality Assurance	AS CERT-□	Yes	Yes	Yes	Yes	Yes	Yes	Yes	Yes	Yes	Yes	Yes
Shorting Bar, Plug-in; Reduces 11.5 V dc to 11 V dc (not with Versions -F or -V)	AS SB-11	Yes	Yes	Yes	Yes	Yes	Yes	Yes	Yes	No	No	No





Table 17. Accessories That Must be Ordered Separately (Continued)

Accessory Description	AS Code Part No. PSS No.	Available with Transmitter Model										
		IAP10 IGP10	IAP10S IGP10S	IAP20 IGP20	IDP10	IDP10S	IGP25 IGP50	IDP25 IDP50	IMV25	IMV30	IMV31	
Orifices: Compact, Integral, Plates												
▶ Compact Orifice (Model CO)	PSS 3-5A1 E	No	Yes	No	Yes	Yes	No	Yes	Yes	Yes	Yes	Yes
▶ Int. Flow Orifice (Model IFO)	PSS 3-5A1 D	No	Yes	No	Yes	Yes	No	Yes	Yes	Yes	Yes	Yes
▶ Int. Flow Orifice Assy (Model IFOA)	PSS 3-5A1 B	No	Yes	No	Yes	Yes	No	Yes	Yes	Yes	Yes	Yes
▶ Int. Flow Orif.-U-Bend (Model IFOU)	PSS 3-5A1 C	No	Yes	No	Yes	Yes	No	Yes	Yes	Yes	Yes	Yes
▶ Orifice Plates	Inside Pages	No	Yes	No	Yes	Yes	No	Yes	Yes	Yes	Yes	Yes
Pressure Seals: Flanged, Threaded, Sanitary, and In-Line Weld; Direct and Remote Mounted.	PSS 2A-1Z11 E and inside pages	Yes	Yes	Yes	Yes	Yes	Yes (a)	Yes (a)	No	No	No	No
Manifolds, 1-, 2-, 3-, and 5-Valve: Standard and Commodity Versions, and Versions for Low Profile (Coplanar) Transmitters	PSS 2B-1Z2 A and inside pages	Yes	Yes	Yes	Yes	Yes	Yes	Yes	Yes	Yes	Yes	Yes

a. Pressure Seals not offered with IGP50 and IDP50 Premium Performance Transmitters.

## INDEX

- Adapters, Conduit Thread
  - 1/2 NPT Brass Cable Gland, page 9
  - M20 to 1/2 NPT ss Adapter, page 9
  - PG 13.5 Plastic Cable Gland, page 9
  - PG 13.5 Brass Cable Gland, page 10
- Bolting (Bolts and Nuts)
  - 17-4 ss Bolting, page 10
  - 316 ss Bolting, page 10
  - B7M Bolting - NACE, page 10
- Brackets, Mounting, page 15
- Calibration
  - Flow Laboratory, page 24
  - Factory Calibration, page 26
- Calibration Screw, page 13
- Certificates, Quality Assurance, page 19
- Cleaning and Degreasing
  - Degreasing - Silicone Fill Only, page 11
  - NACE MR 01-75 Conformance, page 11
  - Oxygen/Chlorine Service-Inert Fill Only, page 11
- Condensing Chamber, page 24
- Conduit Thread Adapters
  - 1/2 NPT Brass Cable Gland, page 9
  - M20 to 1/2 NPT ss Adapter, page 9
  - PG 13.5 Plastic Cable Gland, page 9
  - PG 13.5 Brass Cable Gland, page 10
- Connector, Tubing, page 12
- Configuration, Custom
  - Digital Output Configuration, page 21
  - Custom Configuration per Sales Order, page 21
- Configurators, Integral
  - LCD Indicator w/pushbuttons, page 8
- Configurators, Remote (PC-Based)
  - Model HHT50 (FoxCom/HART), page 7
  - HART Communicator (HART/Fieldbus), page 5
  - Model PC20 (FoxCom/HART), page 6
  - Model PC50 (FoxCom/HART), page 7
  - Model PCMM, page 6
  - Model PCMV (FoxCom/HART), page 5
- Connector, Hose, Flexible, page 23
- Connection, Process, Integral
  - Pulp and Paper Processes, page 35
  - Sanitary Processes, page 32
  - Autoclave F-250 C Internal Conn., page 12
  - G 1/2 Form B External Thread, page 12
  - 1/2 NPT to R 1/2 Adapter, page 13
  - 1/2 NPT External Thread, page 13
- Custody Transfer Lock and Seal, page 18
- Customer Tag, page 19
- External Zero Adjustment, page 18
- Hose Connector, Flexible, page 23
- Indicators, LCD, with Pushbuttons
  - with Window Cover, page 8
  - with Blind Cover, page 8
- Instructions, Transmitter (Paper and DVD-ROM), page 20
- LCD Indicator, with Pushbuttons
  - with Window Cover, page 8
  - with Blind Cover, page 8
- Manifolds, 1-, 2-, 3-, and 5-Valve
  - Block and Bleed Valve (1-Valve), page 38
  - Bypass Manifolds (2-, 3-, and 5-Valves), page 38
- Mounting Brackets, page 15
- Orifices
  - Model CO Compact Orifice, page 27
  - Model IFO Integral Flow Orifice, page 27
  - Model IFOA Integral Flow Orifice Assy, page 27
  - Model IFOU Integral Flow Orifice U-Bend, page 27
  - Orifice Plates, page 29
- Pigtail, Siphon, page 22
- Pipe Saddle, Leveling, page 24
- Power Supply, page 22
- Pressure Regulator, Differential, page 23
- Pressure Seals, page 29
- Primary Devices, page 25
- Process Connections, Integral
  - Pulp and Paper Processes, page 35
  - Sanitary Processes, page 32
  - Autoclave F-250 C Internal Conn., page 12
  - G 1/2 Form B External Thread, page 12
  - 1/2 NPT to R 1/2 Adapter, page 13
  - 1/2 NPT External Thread, page 13
- Product Accessories, page 22
- Product Enhancing Options, page 18
- Process Related Options, page 10
- Product Specifications (PSSs), page 4
- Quality Assurance Certificates, page 19
- Rotameter, page 23
- Seals, Pressure, page 29
- Shorting Bar, Plug-in - Decreases LO Voltage, page 21
- SIL2 Certified HART Transmitters, page 19
- Siphon Pigtail, page 22
- Snubbers, Pressure, page 23
- Static Pressure Rating - Increases HI Press., page 20
- Tag, Customer, page 19
- Temperature Limit - Decreases LO Temp., page 20
- Tubing Connector, page 12
- Valves, Hand, page 22
- Vapor Trap, page 24
- Vent Screw; Located in
  - Process Cover, page 13
  - Process Connector, page 13
- Warranty, Seventeen-Year, page 20
- Zero Adjustment, External, page 18



**NOTES**



### OTHER FOXBORO PRODUCTS

The Foxboro product lines offer a broad range of measurement and instrument products, including solutions for pressure, flow, analytical, temperature, positioning, controlling, and recording. For a list of these offerings, visit our web site at:

[www.fielddevices.foxboro.com](http://www.fielddevices.foxboro.com)