

I/A Series[®] Intelligent Pressure Transmitters

**IAP10 Absolute Pressure and IGP10 Gauge Pressure
with FoxCom Communication**

**Installation, Operation, Calibration, Configuration, and Maintenance
(4 to 20 mA FoxCom)**

Contents

Figures.....	v
Tables.....	vi
1. Introduction	1
General Description	1
Reference Documents	1
Transmitter Identification	2
Standard Specifications	5
Product Safety Specifications	11
ATEX and IECEx Warnings	13
ATEX Compliance Documents	13
IECEx Compliance Documents	14
2. Installation	15
Transmitter Mounting	15
Sanitary Process Connection	16
Pulp and Paper Process Connection	18
Sleeve Type Connector	18
Threaded Type Connector	19
Typical Transmitter Piping	20
Positioning the Housing	21
Positioning the Display	22
Setting the Write Protect Jumper	22
Cover Locks	23
Wiring	23
Accessing Transmitter Field Terminals	23
Wiring a Transmitter Having a Digital Output Signal	24
Wiring a Transmitter Having a 4 to 20 mA Output Signal	26
3. Operation Via Local Display	31
Entering Numerical Values	32
Viewing the Database	33
Viewing the Pressure Range	33
Testing the Display	33
Error Messages	34
4. Calibration	35

General Calibration Notes	35
Calibration Setup	37
Setup of Electronic Equipment	38
Field Calibration Setup	38
Bench Calibration Setup	39
Calibration Using a PC20	39
Calibration Using a PC50	39
Calibration Using the Optional Local Display	39
Zero Adjustment Using External Zero Button	43
Error Messages	44
5. Configuration.....	45
Configurable Parameters	45
Configuration Using a PC20	46
Configuration Using a PC50	46
Configuration Using the Optional Local Display	46
Character Lists	56
Error Messages	57
6. Maintenance.....	59
Fault Analysis	59
Parts Replacement	59
Replacing the Terminal Block Assembly	59
Replacing the Electronics Module Assembly	60
Removing and Reinstalling a Housing Assembly	61
Adding the Optional Display	62
Replacing the Sensor Assembly	62
Index	65

Figures

1	Transmitter Identification	3
2	Top Level Structure Diagram	4
3	Minimum Allowable Absolute Pressure vs. Process Temperature with Fluorinert Fill Fluid	7
4	IAP10 and IGP10 Transmitter Mounting	16
5	Mounting of Transmitter with Sanitary Tri-Clamp Type Connection	16
6	Mounting of Transmitter with Sanitary Mini Tank Spud Seal	17
7	Welding Procedure	18
8	Mounting of Transmitter with Sleeve Type Pulp and Paper Process Connection	19
9	Mounting of Transmitter with Threaded Type Pulp and Paper Process Connection	20
10	Typical Transmitter Piping	21
11	Hot Process Piping	21
12	Housing Screw or Clip Location	22
13	Cover Lock Location	23
14	Accessing Field Terminals	24
15	Identification of Field Terminals	24
16	Typical Transmitter Wiring to an I/A Series System	25
17	Supply Voltage and Loop Load	27
18	Loop Wiring 4 to 20 mA Output Transmitters	29
19	Wiring Several 4 to 20 mA Transmitters to a Common Power Supply	29
20	Local Display Module	31
21	Top Level Structure Diagram	32
22	Display Test Segment Patterns	34
23	4 to 20 mA Output Calibration Setup of Electronic Equipment	38
24	Transmitter Piping	38
25	Bench Calibration Setup	39
26	Calibration Structure Diagram	41
27	Calibration Structure Diagram (Continued)	42
28	Configuration Structure Diagram	49
29	Configuration Structure Diagram (Continued)	50
30	Configuration Structure Diagram (Continued)	51
31	Replacing the Electronics Module Assembly and Display	61

Tables

1	Reference Documents	1
2	Minimum Loop Load and Supply Voltage Requirements	9
3	Electrical Safety Specifications	11
4	Operation Error Messages	34
5	Calibration Menu	40
6	Calibration Error Messages	44
7	Configurable Parameters	45
8	Configuration Menu	47
9	Alphanumeric Character List	56
10	Numeric Character List	56
11	Configuration Error Messages	57

1. Introduction

General Description

The IAP10-D Intelligent Absolute Pressure and the IGP10-D Intelligent Gauge Pressure Transmitters measure pressure by applying the pressure to a silicon strain gauge microsensor within the sensor assembly. This microsensor converts the pressure to a change in resistance, and the resistance change is converted to a 4 to 20 mA or digital signal proportional to the pressure. This measurement signal is transmitted to remote receivers over the same two wires that supply power to the transmitter electronics. These wires also carry two-way data signals between the transmitter and a PC-Based configurator or an I/A Series system.

The measurement signal can be a digital signal for full communication with the I/A Series system or a 4 to 20 mA output signal. The communication function permits you to reconfigure or rerange a transmitter from a remote device, such as a personal computer or I/A Series system.

The IAP10 and IGP10 can be supplied with direct connected pressure seals or with remote pressure seals.

For more detailed information on the principle of operation of the transmitter, refer to document TI 037-096, available from Invensys.

Reference Documents

Table 1. Reference Documents

Document	Description
Dimensional Prints	
DP 020-217	Dimensional Print – IAP10 and IGP10 Pressure Transmitters with Pulp and Paper Process Connections
DP 020-218	Dimensional Print – IAP10 and IGP10 Pressure Transmitters with Sanitary Tri-Clamp Type Process Connections
DP 020-219	Dimensional Print – IAP10 and IGP10 Pressure Transmitters with Sanitary Mini Tank Spud Process Connections
DP 020-342	Dimensional Print – PSFLT Pressure Seals
DP 020-343	Dimensional Print – PSFPS and PSFES Pressure Seals
DP 020-344	Dimensional Print – IGP10 Gauge Pressure Transmitters (High Pressure)

Table 1. Reference Documents (Continued)

Document	Description
DP 020-345	Dimensional Print – PSFAR Pressure Seals
DP 020-346	Dimensional Print – PSFAD Pressure Seals
DP 020-347	Dimensional Print – PSTAR Pressure Seals
DP 020-348	Dimensional Print – PSTAD Pressure Seals
DP 020-349	Dimensional Print – PSISR Pressure Seals
DP 020-350	Dimensional Print – PSISD Pressure Seals
DP 020-351	Dimensional Print – PSSCR Pressure Seals
DP 020-353	Dimensional Print – PSSCT Pressure Seals
DP 020-354	Dimensional Print – PSSSR Pressure Seals
DP 020-355	Dimensional Print – PSSST Pressure Seals
DP 020-447	Dimensional Print – IAP10 and IGP10 Pressure Transmitters
Parts Lists	
PL 009-006	Parts List – IAP10 Absolute and IGP10 Gauge Pressure Transmitters
PL 009-010	Parts List – IGP10 High Gauge Pressure Transmitter
Instructions	
B0193XX	Checklist for FoxCom Measurement Integration
MI 020-369	Instruction – Pressure Seals
MI 020-427	Instruction – Intrinsic Safety Connection Diagrams and Nonincendive Circuits
MI 020-495	Instruction – PC20 Intelligent Transmitter Configurator
MI 020-501	Instruction – PC50 Intelligent Field Device Tool (Installation and Parts List)
MI 020-504	Instruction – PC50 Intelligent Field Device Tool (Operation Using FoxCom Protocol)
MI 022-138	Instruction – Bypass Manifolds - Installation
Technical Information	
TI 37-75b	Technical Information – Transmitter Material Selection Guide
TI 037-097	Technical Information – Process Sealing of I/A Series Pressure Transmitters for use in Class 1, Zone 0, 1, and 2 Hazardous Locations

Transmitter Identification

See Figure 1 for transmitter data plate contents. For a complete explanation of the Model Number code, see the parts list. The firmware version is identified on the top line of the display when **VIEW DB** (View Database) is selected in the top level structure.

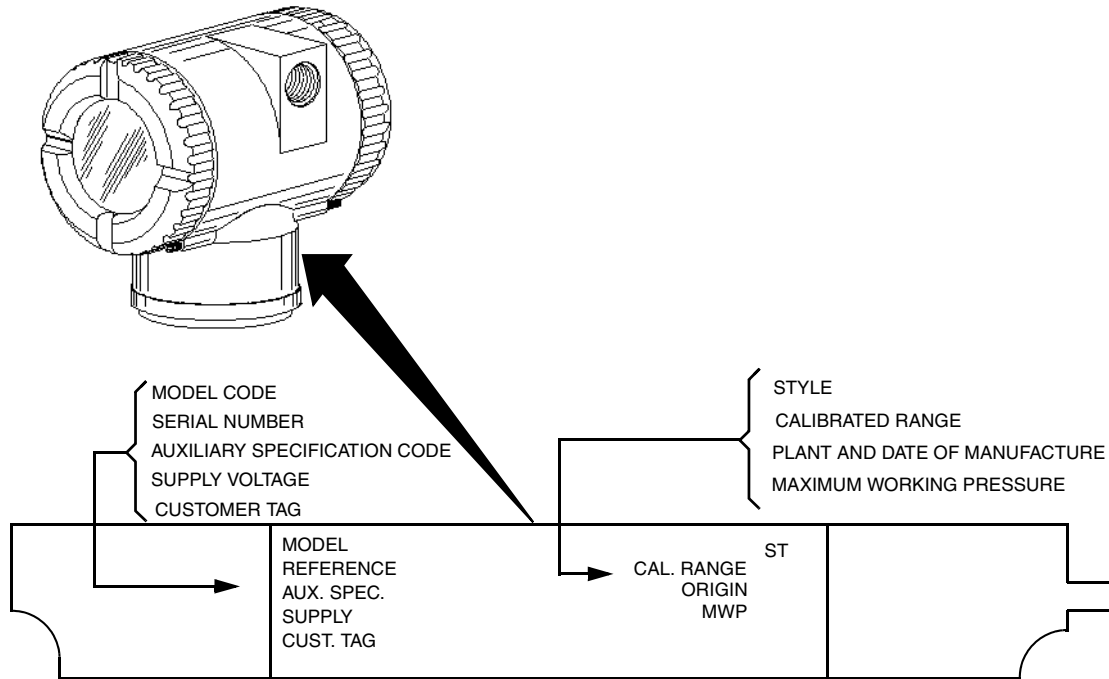

Figure 1. Transmitter Identification

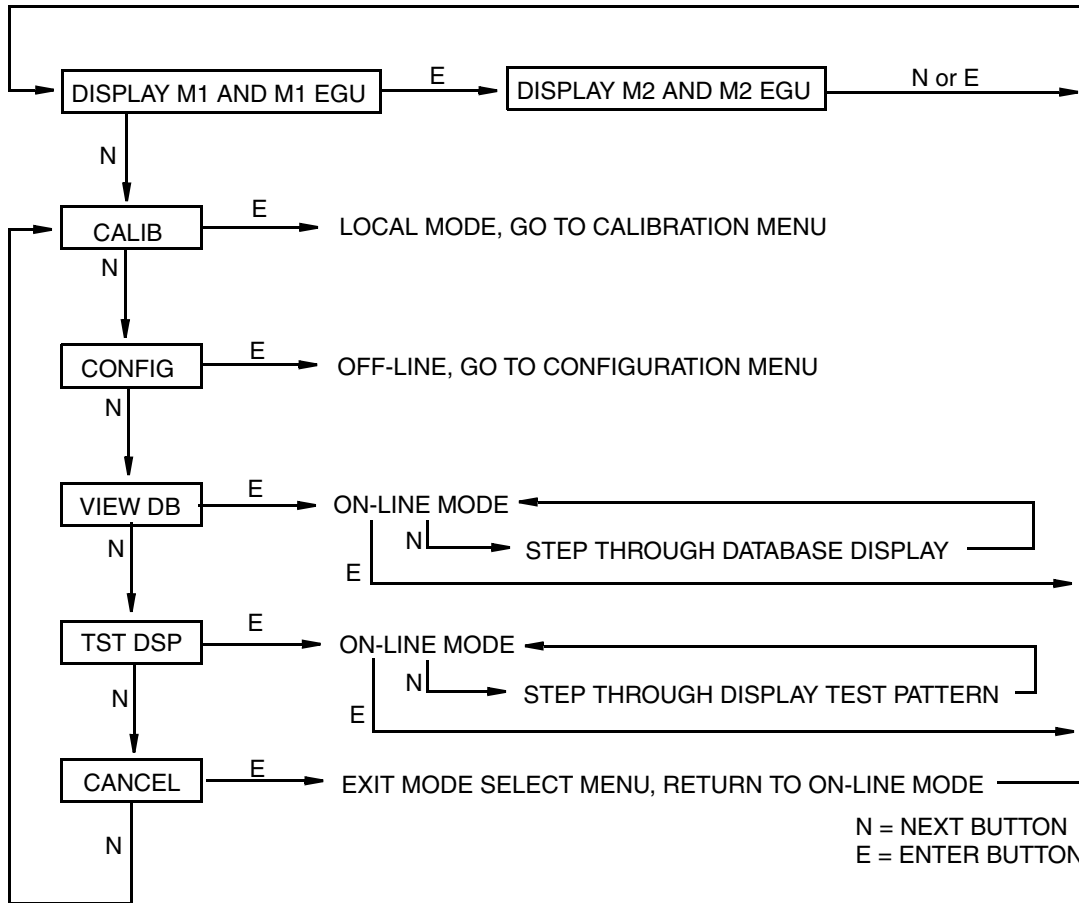

Figure 2. Top Level Structure Diagram

Standard Specifications

Operative Limits

Influence	Operative Limits
Sensor Body Temperature ^(a)	-46 and +121°C (-50 and +250°F)
Silicone Fill Fluid	-29 and +121°C (-20 and +250°F)
Fluorinert Fill Fluid	-18 and +121°C (0 and 250°F)
Neobee Fill Fluid	-7 and +82°C (20 and 180°F)
pvdf Inserts	
Electronics Temperature With LCD Display	-40 and +85°C (-40 and +185°F) ^(b) -40 and +85°C (-40 and +185°F) ^(c)
Relative Humidity	0 and 100%
Supply Voltage	11.5 and 42 V dc ^(d)
Output Load ^(e)	0 and 1450 ohms
Mounting Position	No Limit
Vibration	6.3 mm (0.25 in) double amplitude from 5 to 15 Hz with aluminum housing and from 5 to 9 Hz with 316 ss housing. 0 to 30 m/s (0 to 3 “g”) from 15 to 500 Hz with aluminum housing and 0 to 10 m/s (0 to 1 “g”) from 9 to 500 Hz with 316 ss housing.

(a) Refer to MI 020-369 for temperature limits with pressure seals.

(b) -40 and +75°C (-40 and +167°F) for transmitters with ATEX flameproof classification.

(c) Display updates are slowed and readability decreased below temperatures of -20°C (-4°F).

(d) 11 V dc with optional shorting block (AS code SB-11).

(e) 250 Ω minimum load is required for communication with a PC-Based Configurator.

Span and Range Limits

Span Limit Code	Span Limits ^(a)	Range Limits ^(a)
C	7 and 210 kPa 28 and 840 inH ₂ O	0 and 210 kPa 0 and 840 inH ₂ O
D	0.07 and 2.1 MPa 10 and 300 psi 23 and 690 ftH ₂ O	0 and 2.1 MPa 0 and 300 psi 0 and 690 ftH ₂ O
E	0.7 and 21 MPa 100 and 3000 psi	0 and 21 MPa 0 and 3000 psi
F ^(b,c)	14 and 42 MPa 2000 and 6000 psi	0 and 42 MPa 0 and 6000 psi
G ^(b,c)	35 and 105 MPa 5000 and 15,000 psi	0 and 105 MPa 0 and 15,000 psi
H ^(b,c)	70 and 210 MPa 10,000 and 30,000 psi	0 and 210 MPa 0 and 30,000 psi

Span Limit Code	Span Limits ^(a)	Range Limits ^(a)
K ^(b,c)	17 and 52 MPa 2500 and 7500 psi	0 and 52 MPa 0 and 7500 psi

(a) Values listed are in absolute or gauge pressure units, as applicable.

(b) Not available with pressure seals.

(c) Applicable to IGP10 only

Maximum Overrange Pressure and Proof Pressure

Span Limit Code	Maximum Overrange Pressure ^(a)	Proof Pressure ^{(a)(c)}
C	0.31 MPa (45 psi)	827 kPa (120 psi)
D	3.1 MPa (450 psi)	8.27 MPa (1200 psi)
E	31 MPa (4500 psi)	79.3 MPa (11,500 psi)
F ^(b)	58 MPa (8400 psi)	152 MPa (22,000 psi)
G ^(b)	137 MPa (19,500 psi)	310 MPa (45,000 psi)
H ^(b)	231 MPa (33,000 psi)	567 MPa (81,000 psi)
K ^(b)	79 MPa (11,250 psi)	155 MPa (22,500 psi)

(a) Values listed are in absolute or gauge pressure units, as applicable.

(b) Applicable to IGP10 only.

(c) Meets ANSI/ISA Standard S82.03-1988

— CAUTION

1. Exceeding the overrange pressure limit for the transmitter can cause damage to the transmitter, degrading its performance.
2. The transmitter may be nonfunctional after application of the proof pressure.

Suppressed Zero

For applications requiring a suppressed zero, the maximum span and the upper and lower range limits of the transmitter can not be exceeded.

Sensor Fill Fluid

Silicone Oil (DC 200) or Fluorinert (FC-43)

Neobee M-20 (for transmitters with sanitary process connection)

Not applicable with IGP10 Span Limit Codes G and H.

Minimum Allowable Absolute Pressure vs. Process Temperature

IGP10: Not Applicable.

IAP10: With Silicone Fill Fluid: up to 120 °C (250 °F) at full vacuum.

With Fluorinert Fill Fluid: Refer to Figure 2.

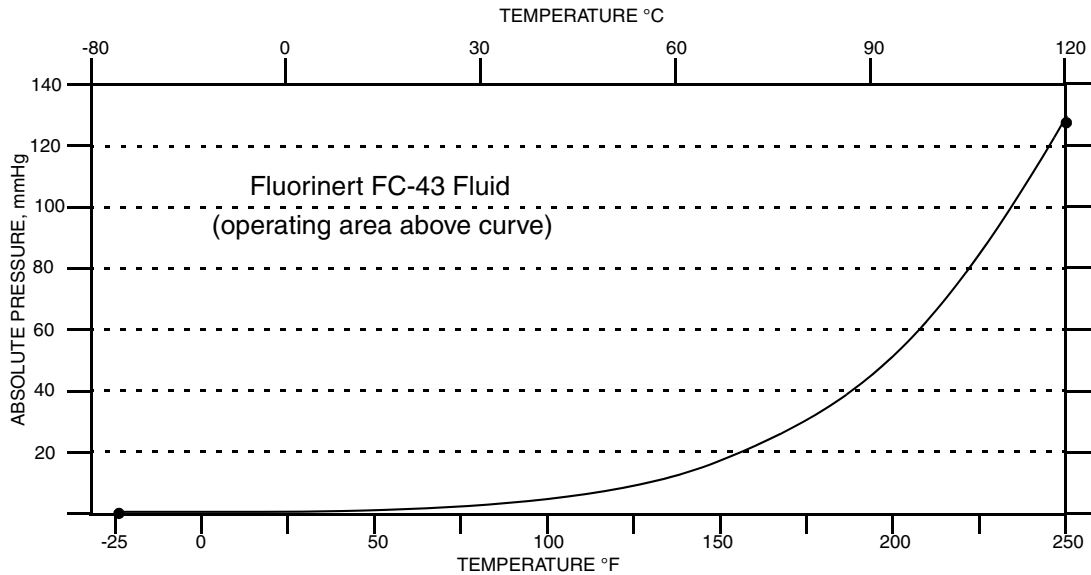

Figure 3. Minimum Allowable Absolute Pressure vs. Process Temperature with Fluorinert Fill Fluid

Mounting Position

The transmitter can be mounted in any orientation. It can be directly mounted to the process with either the direct connected or pipe mounted designs. The housing can be rotated up to one full turn to any desired position for access to adjustments, display, or conduit connections. See “Positioning the Housing” on page 21. The display (if present) can also be rotated in the housing to any of four different positions at 90° increments. See “Positioning the Display” on page 22.

NOTE

Position effect zero shift for all calibrated spans can be eliminated by readjusting zero output after installation.

Approximate Mass

IAP10, IGP10:	1.5 kg (3.3 lb)
With Optional 316 ss Housing:	Add 1.1 kg (2.4 lb)
With Pressure Seals:	Varies with seal used

Process Connections

IAP10 and IGP10 transmitters can be directly connected to the process using its 1/2 NPT external thread or optional G 1/2 B connection. If the optional mounting bracket is used, the transmitter can be connected to the process via the 1/2 NPT external thread, 1/4 NPT internal thread, or optional G 1/2 B connection.

Using the optional mounting bracket, IGP10 transmitters with Span Limit Code G can connect to the process via the 1/4 NPT internal thread, G 1/2 B external thread, or Autoclave F-250-C with 9/16-18 internal gland thread.

Using the optional mounting bracket, IGP10 transmitters with Span Limit Code H are connected using the Autoclave F-250-C with 9/16-18 internal gland thread.

IAP10 and IGP10 Transmitters with a sanitary process connection connect to the process via a Tri-Clamp type process connector, a threaded connection, or a mini tank spud.

IAP10 and IGP10 Transmitters with a pulp and paper process connection connect to the process via a threaded or sleeve type connection.

Process Wetted Materials

IAP10 or IGP10

Diaphragm:

Co-Ni-Cr, 316L ss, or Hastelloy C

Process Connectors:

316L ss or Hastelloy C

IGP10 with Span Limit Code G:

15-5 ss or Inconel X-750

IGP10 with Span Limit Code H:

13-8 Mo ss

Pressure Seals:

Refer to MI 020-369

Sanitary Process Connections:

316L ss, Hastelloy C

Pulp and Paper Process Connections

316L ss, Hastelloy C

Reference Pressure Side (Low Pressure Side) Materials

IGP10: Silicon, Pyrex, RTV, 316L ss, and Ceramic

Not applicable with IGP10 Span Limit Codes G and H

Process Pressure and Temperature Limits for Pressure Seals

Refer to MI 020-369

Electrical Connections

Field wires enter through 1/2 NPT, PG 13.5, or M20 threaded entrances on either side of the electronics housing. Leads terminate under screw terminals and washers on the terminal block in the field terminal compartment. To maintain RFI/EMI, environmental, and explosionproof ratings, unused conduit connection must be plugged with metal plug (provided), inserted to five full threads for 1/2 NPT connections; seven full threads for M20 and PG 13.5 connections.

Field Wiring Reversal

Accidental reversal of field wiring will not damage the transmitter, provided the current is limited to 1 A or less by active current limiting or loop resistance. Sustained currents of 1 A will not damage the electronics module or sensor but could damage the terminal block assembly and external instruments in the loop.

Adjustable Damping

The transmitter response time is normally 1.0 second or the electronically adjustable setting of 0.00 (none), 0.25, 0.50, 1, 2, 4, 8, 16, or 32 seconds, whichever is greater, for a 90% recovery from an 80% input step as defined in ANSI/ISA S51.1.

Output Signal

4 to 20 mA dc linear.

Zero and Span Adjustments

The zero and span is adjustable from the PC-Based Configurator or I/A Series console with appropriate fieldbus module (FBM). They are also adjustable at the transmitter using the display. An optional self-contained moisture sealed pushbutton assembly allows local resetting of zero without removing the housing cover.

Power-up Time

Less than 2.0 seconds for output to reach the first valid measurement, then at the electronic damping rate to reach the final measured variable value.

Supply Voltage

Power supply must be capable of providing 22 mA when the transmitter is configured for 4 to 20 mA output. Ripple of up to 2 V pp (50/60/100/120 Hz) is tolerable, but instantaneous voltage must remain within specified range.

The supply voltage and loop load must be within specified limits. This is explained in detail in “Wiring” in the Installation section. A summary of the minimum requirements are listed in Table 2.

Table 2. Minimum Loop Load and Supply Voltage Requirements

	PC-Based Configurator Communication	No PC-Based Configurator Communication
Minimum Resistance	250 Ω	0
Minimum Supply Voltage	17 V	11.5 V

Electrical Ground Connections

The transmitter is equipped with an internal ground connection within the field wiring compartment and an external ground connection at the base of the electronics housing. To minimize galvanic corrosion, place the wire lead or terminal between the captive washer and loose washer on the external ground screw. If shielded cable is used, earth (ground) the shield at the field enclosure **only**. Do **not** ground the shield at the transmitter.

Test Points

The two lower banana plug receptacles (designated **CAL**) can be used to check transmitter output when configured for 4 to 20 mA. Measurements should be 100-500 mV dc for 0-100% transmitter output.

Remote Communications

The transmitter communicates bidirectionally over the 2-wire field wiring to a PC-Based Configurator (anywhere in a nonhazardous area) along the loop and/or to the I/A Series system. The information that can be continuously displayed is:

- ◆ Process Measurement
- ◆ Transmitter Temperature (electronics and sensor)
- ◆ Equivalent mA Output (if so configured)
- ◆ Transmitter Model, Serial Number, and Firmware Version

The information that can be remotely displayed and reconfigured includes:

- ◆ Output in mA, Percent, or Engineering Units (EGU)
- ◆ Zero and Span, including reranging
- ◆ Zero Elevation or Suppression
- ◆ Linear Output
- ◆ 4 to 20 mA or Digital Output
- ◆ Pressure or Plant EGU
- ◆ Temperature Sensor Failure Strategy
- ◆ Electronic Damping
- ◆ External Zero Enable or Disable
- ◆ Failsafe Direction
- ◆ Tag Number and Tag Name, and Device Name
- ◆ Transmitter Location
- ◆ Calibrator's Initials
- ◆ Date of Last Calibration

Communications Format

Communication is based upon the FSK (Frequency Shift Keying) technique. The frequencies are superimposed on the transmitter power/signal leads.

4 to 20 mA Output

The transmitter sends its pressure measurement to the loop as a continuous 4 to 20 mA dc signal. This version also communicates digitally with a PC-Based Configurator at distances up to 1800 m (6000 ft). Communication between the remote configurator and the transmitter does not disturb the 4 to 20 mA output signal.

Other specifications are:

Data Transmission Rate	600 Baud
4 to 20 mA Update Rate	30 times/second minimum
Output when Underrange	3.75 mA
Output when Overage	21 mA

Output for Fail Low	3.6 mA
Output for Fail High	22 mA
Output when Offline	Last value or configurable from 4 to 20 mA

Digital Output

The transmitter can be configured to send its pressure measurement to the I/A Series system as a digital signal. Remote communication between the transmitter and a PC-Based Configurator or any I/A Series system console can be accommodated up to 600 m (2000 ft) away from the FBM. Other specifications are:

Data Transmission Rate	4800 Baud
Digital Output Update Rate	10 times/second (matching the FBM)

Product Safety Specifications

— DANGER

To prevent possible explosions and to maintain flameproof, explosionproof, and dust-ignitionproof protection, observe applicable wiring practices. Plug unused conduit opening with the provided metal pipe plug. Both plug and conduit must engage a minimum of five full threads for 1/2 NPT connections; seven full threads for M20 and PG 13.5 connections.

— WARNING

To maintain IEC IP66/IP68 and NEMA Type 4X protection, the unused conduit opening must be plugged with the metal plug provided. Use a suitable thread sealant on both conduit connections. In addition, the threaded housing covers must be installed. Turn covers to seat the O-ring into the housing and then continue to hand tighten until the cover contacts the housing metal-to-metal.

— NOTE

1. These transmitters have been designed to meet the electrical safety description listed in Table 3. For detailed information or status of testing laboratory approvals/certifications, contact Invensys.
2. Wiring restrictions required to maintain electrical certification of the transmitter are provided in these instructions. See “Wiring” on page 23.

Table 3. Electrical Safety Specifications

Agency Certification, Types of Protection, and Area Classification	Application Conditions	Electrical Safety Design Code
ATEX flameproof: II 2 GD EEx d IIC, Zone 1.	SIRA 04ATEX1349 Temperature Class T6 T85°C Ta = -40 to + 75°C	D

Table 3. Electrical Safety Specifications (Continued)

Agency Certification, Types of Protection, and Area Classification	Application Conditions	Electrical Safety Design Code
ATEX intrinsically safe: II 1 GD EEx ia IIC, Zone 0 or II 1/2 GD EEx ib IIC, Zone 0 and 1.	KEMA 00ATEX1009X Temperature Class T4 at 80°C, T5 at 40°C, and T6 at 40°C maximum ambient.	E
ATEX protection n: II 3 GD EEx nL IIC, Zone 2.	KEMA 00ATEX1060X Temperature Class T4 at 80°C, T5 at 70°C, and T6 at 40°C maximum ambient.	N
ATEX multiple certifications, ia & ib and n. Refer to Codes E and N for details.	Applies to Codes E and N but not Code D. ^(a)	M
ATEX multiple certifications, ia & ib, d, and n. Refer to Codes D, E and N for details.	Applies to Codes D, E, and N. ^(a)	P
CSA intrinsically safe for Class I, Division 1, Groups A, B, C, and D; Class II, Division 1, Groups E, F, and G; Class III, Division 1.	Connect per MI 020-427. Temperature Class T6 at 40°C (104°F), and T4A at 85°C (185°F) maximum ambient.	C
CSA explosionproof for Class I, Division 1, Groups B, C, and D; dust-ignitionproof for Class II, Division 1, Groups E, F, and G; Class III, Division 1.	Maximum Ambient Temperature 85°C (185°F).	
CSA for Class I, Division 2, Groups A, B, C, and D; Class II, Division 2, Groups F and G; Class III, Division 2.	Temperature Class T6 at 40°C (104°F) and T4A at 85°C (185°F) maximum ambient.	
CSA field device zone certified flameproof Ex d IIC. Also, all certifications of Code C above.	Maximum Ambient Temperature 85°C (185°F).	B
CSA intrinsically safe for Class I, Division 1, Groups A, B, C, and D; Class II, Division 1, Groups E, F, and G; Class III, Division 1.	Connect per MI 020-427. Temperature Class T6 at 40°C (104°F), and T4A at 85°C (185°F) maximum ambient.	L (IGP10 only)
CSA for Class I, Division 2, Groups A, B, C, and D; Class II, Division 2, Groups F and G; Class III, Division 2.	Temperature Class T6 at 40°C (104°F) and T4A at 85°C (185°F) maximum ambient.	

Table 3. Electrical Safety Specifications (Continued)

Agency Certification, Types of Protection, and Area Classification	Application Conditions	Electrical Safety Design Code
FM intrinsically safe for Class I, Division 1, Groups A, B, C, and D; Class II, Division 1, Groups E, F, and G; Class III, Division 1.	Connect per MI 020-427. Temperature Class T4A at 40°C (104°F) and T4 at 85°C (185°F) maximum ambient.	F
FM explosionproof for Class I, Division 1, Groups B, C, and D; dust-ignitionproof for Class II, Division 1, Groups E, F, and G; Class III, Division 1.	Temperature Class T6 at 80°C (176°F) and T5 at 85°C (185°F) maximum ambient.	
FM nonincendive for Class I, Division 2, Groups A, B, C, and D; Class II, Division 2, Groups F and G; Class III, Division 2.	Temperature Class T4A at 40°C (104°F) and T4 at 85°C (185°F) maximum ambient.	
FM field device zone certified flameproof AEx d IIC. Also, all certifications of Code F above.	Temperature Class T6 at 75°C (167°F) maximum ambient.	G
FM intrinsically safe for Class I, Division 1, Groups A, B, C, and D; Class II, Division 1, Groups E, F, and G; Class III, Division 1.	Connect per MI 020-427. Temperature Class T4A at 40°C (104°F), and T4 at 85°C (185°F) maximum ambient.	R (IGP10 only)
FM nonincendive for Class I, Division 2, Groups A, B, C, and D; Class II, Division 2, Groups F and G; Class III, Division 2.	Temperature Class T4A at 40°C (104°F) and T4 at 85°C (185°F) maximum ambient.	
IECEx flameproof: Ex d IIC, Zone 1.	IECEx SIR 05.0003X Temperature Class T6, Ta = -40 to +75°C	V

(a) User must permanently mark (check off in rectangular block on data plate) one type of protection only (ia and ib, d, or n). This mark cannot be changed once it is applied.

ATEX and IECEx Warnings

Do not open while circuits are alive.

ATEX Compliance Documents

EN 50014: 1997 (inc amendments A1 and A2)

EN 50018: 2000 (inc amendment A1)

EN 50020: 1994

EN 50281-1-1: 1998

EN 50284: 1999

EN 50021: 1999

IECEX Compliance Documents

IEC 60079-0 (Edition 3.1): 2000

IEC 60079-1 (Edition 5): 2003

2. Installation

— **! CAUTION** —

To avoid damage to the transmitter sensor, do not use any impact devices, such as an impact wrench or stamping device, on the transmitter.

— **NOTE** —

1. The transmitter should be mounted so that any moisture condensing or draining into the field wiring compartment can exit through one of the two threaded conduit connections.
 2. Use a suitable thread sealant on all connections.
-

Transmitter Mounting

The IAP10 and IGP10 transmitters with the 1/2 NPT external thread can be directly connected to the process or mounted to a vertical or horizontal pipe or a surface using the optional mounting set. See Figure 4.

For dimensional information, refer to DP 020-447. For IGP10 transmitters with Span Limit Code G, H, or K, refer to DP 020-344.

— **NOTE** —

1. Do **not** directly mount the IAP10 and IGP10 transmitters to the process using the 1/4 NPT internal thread. This thread should only be used to connect to the process when the transmitter is mounted with an optional (-M1 through -M6) mounting set.
 2. Do **not** directly mount IGP10 transmitters with Span Limit Code G or H. Use the optional mounting set as shown in Figure 4.
 3. Do **not** mount IAP10 or IGP10 transmitters using the conduit connection and optional mounting set when vibration conditions exceed 20 m/s^2 (2 “g”).
 4. If the transmitter is not installed in the vertical position, readjust the zero output to eliminate the position zero effect. Be aware that an absolute pressure transmitter cannot be zeroed by venting the transmitter to atmosphere.
-

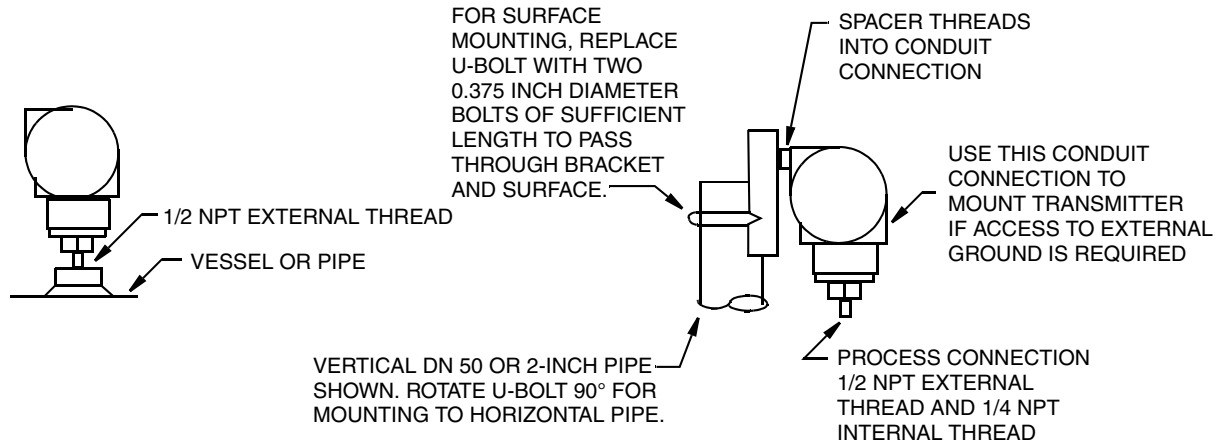

Figure 4. IAP10 and IGP10 Transmitter Mounting

Sanitary Process Connection

The IAP10 and IGP10 transmitters with a sanitary process connector employ a Tri-Clamp type connection or mini tank spud seal. Install the transmitter as shown in Figures 5 and 6. For dimensional information, see the following documents:

Tri-Clamp Type Connector: DP 020-218

Mini Tank Spud Connector: DP 020-219

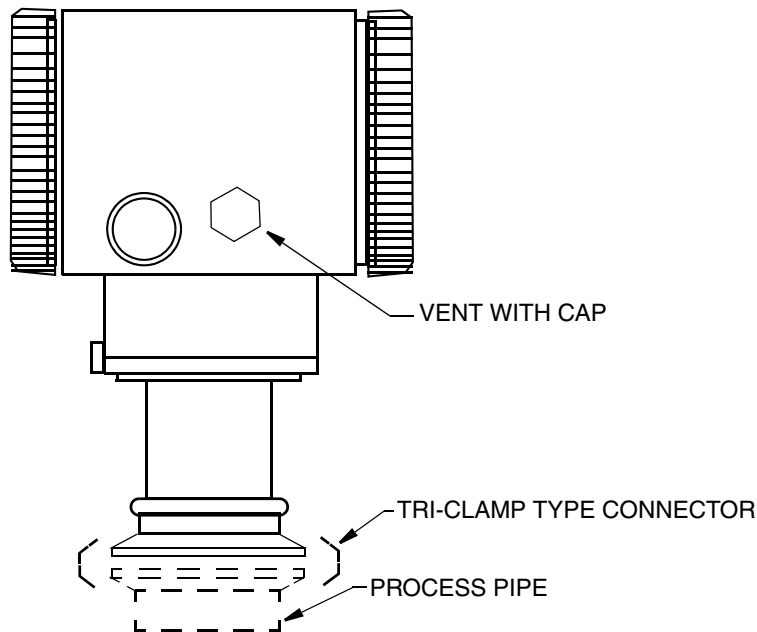

Figure 5. Mounting of Transmitter with Sanitary Tri-Clamp Type Connection

NOTE

1. If the transmitter is to be mounted horizontally (side of a tank), the housing should be oriented so that the vent is self draining. **Do not mount the vent facing up.**

2. If the vent is to face down, it is recommended that the protective cap be removed.
 3. If the vent clogs, replace it with Foxboro Part Number D0186DQ (W.L.Gore part number PMF100318). It is recommended that spare vents be stocked and replaced at a predetermined interval as part of preventive maintenance. When installing a new vent, the applied torque should be 0.6 to 0.8 N•m (5 to 7 in•lb).
 4. If the transmitter is subject to routine wash down such as in typical sanitary applications and the vent is orientated so that it is self draining, the vent will stay clear and longer intervals between preventive maintenance may be realized.
 5. If the vent becomes clogged, the resulting pressure measurement error may be as much as 1.5 inH₂O per degree C change in temperature. This error is positive with decreasing temperature and negative with increasing temperature.
-

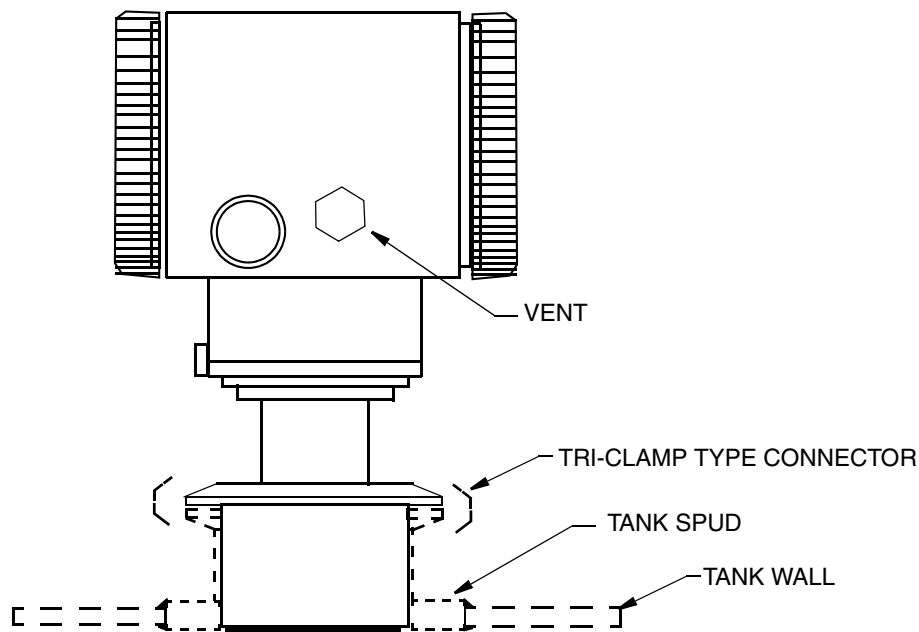

Figure 6. Mounting of Transmitter with Sanitary Mini Tank Spud Seal

The tank spud must be welded into a hole cut in the tank as follows:

1. Cut a hole into the process vessel to accept the spud. The spud should fit snugly and uniformly. The nominal diameter of the spud is: 3.73 inch (94.7 mm). To assure that the seal is always covered by process fluid, the top of the hole should be below the minimum measurement level.
2. Position the spud mounting ring so that it aligns as close as possible with the inside wall of the tank and that the weep hole is at the bottom.
3. Tack weld the spud mounting ring to the outside of the tank in four places.
4. Weld the spud mounting ring to the inner surface of the tank per the following notes.

— **NOTE** —

1. Spud is 316 stainless steel. Use compatible welding rod. Do not distort spud mounting ring by using excessive heat.

2. Weld the spud mounting ring in sections as indicated in Figure 7.
 3. After each section is welded, cool right away with water until the temperature is less than 700°F (370°C) before welding the next section.
-
5. Grind the weld smooth so that the surface is free from irregularities where dirt can lodge.
 6. Outer surface can be welded if desired after inner weld is completed.

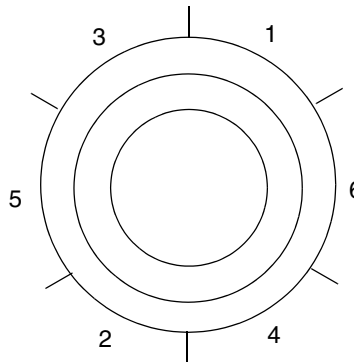

Figure 7. Welding Procedure

Pulp and Paper Process Connection

The IAP10 and IGP10 transmitters with a pulp and paper process connector are available in two designs - sleeve type and threaded type. Install the transmitter as explained below. For dimensional information, see DP 020-217.

Sleeve Type Connector

1. Cut a hole into the process vessel to accept the weld spud. The spud should fit snugly and uniformly. The nominal diameter of the spud is:
For nominal 1 inch connector: 1.32 inch (33.4 mm)
For Nominal 1 1/2 inch connector: 1.90 inch (48.3 mm)
2. Position the sleeve into the hole so that it aligns as close as possible with the inside wall of the vessel
3. Tack weld using the welding sequence shown in Figure 7. Cool each section with water until the temperature is below 700°F (370°C) before proceeding to the next section.
4. Weld the circumference of the sleeve using compatible stainless steel welding rod.

NOTE

The welder should meet the requirements of ANSI B31.3, ASME Section IX or other codes, if applicable.

5. Lubricate the O-ring with appropriate lubricant and install it into the sleeve, ensuring that it is properly seated.

— NOTE

If the gasket is not properly seated, a process leak may occur.

6. Insert the transmitter sensor into the sleeve and hold it in place with cap screws.

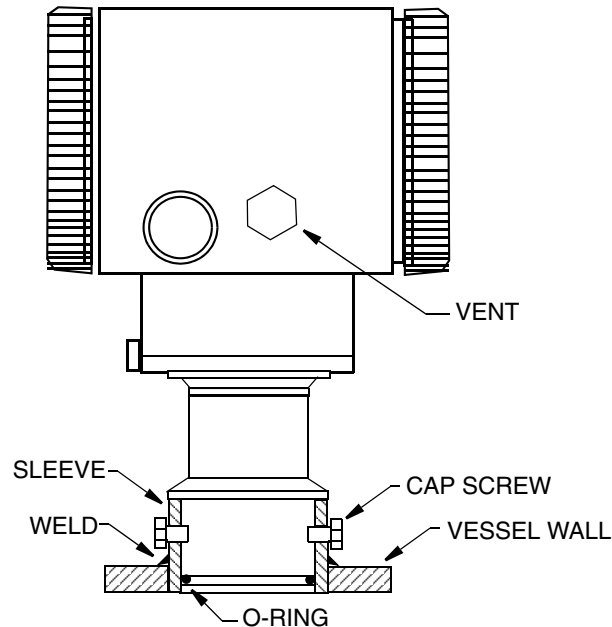

Figure 8. Mounting of Transmitter with Sleeve Type Pulp and Paper Process Connection

Threaded Type Connector

1. Cut a hole into the process vessel to accept the weld spud. The spud should fit snugly and uniformly. The nominal diameter of the spud is:
 For nominal 1 inch connector: 1.50 inch (38.1 mm)
 For nominal 1 1/2 inch connector: 2.38 inch (60.3 mm)
 For nominal 1 1/2 inch connector for Ametek spud: 1.99 inch (50.5 mm)
 Position the connector into the hole so that it aligns as close as possible with the inside wall of the vessel
2. Tack weld using the welding sequence shown in Figure 7. Cool each section with water until the temperature is below 700°F (370°C) before proceeding to the next section.

— NOTE

Invensys recommends using a heat sink during this operation.

1 inch size: Part Number N1214YS

1 1/2 inch size: Part Number N1214YR

3. Weld the circumference of the connector using compatible stainless steel welding rod.

— NOTE

The welder should meet the requirements of ANSI B31.3, ASME Section IX or other codes, if applicable.

4. After the connector has cooled, remove the heat sink.
5. Lubricate the gasket with appropriate lubricant and install it into the connector, ensuring that it is properly seated.

— **NOTE** —

If the gasket is not properly seated, a process leak may occur.

6. Thread the sensor into the connector hand tight. Then tighten approximately 1/8 turn more.

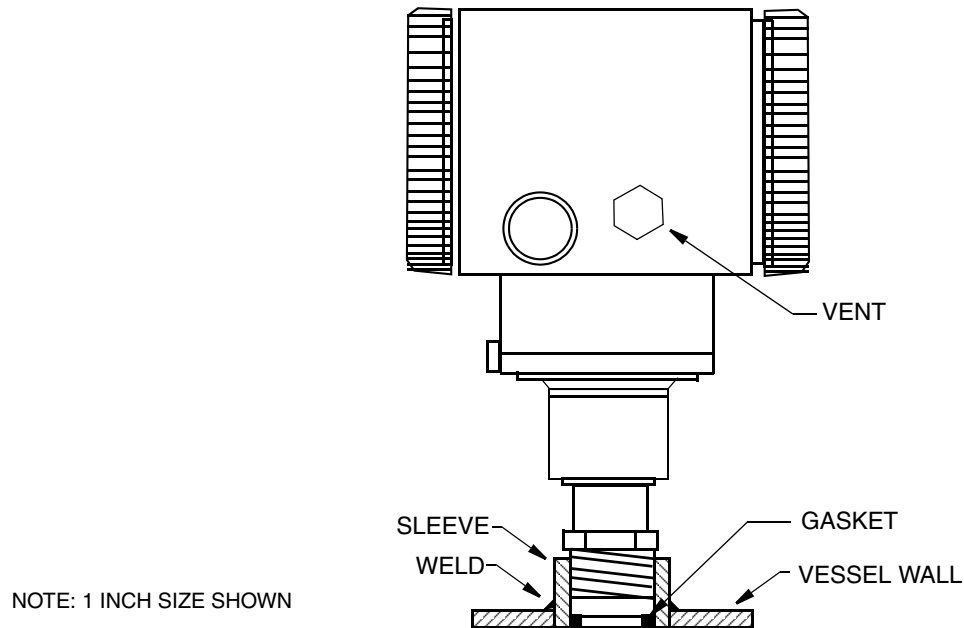

Figure 9. Mounting of Transmitter with Threaded Type Pulp and Paper Process Connection

Typical Transmitter Piping

Figure 10 shows a typical piping application. Calibration supply pressure can be applied via a calibration screw. The lower conduit port can be used as a drain for moisture buildup in terminal compartment.

— **NOTE** —

1. 1. Invensys recommends the use of snubbers in installations prone to high levels of fluid pulsations.
 2. 2. IAP10 and IGP10 Transmitters mounted directly to process piping or a pressure vessel, could require the use of a shutoff valve (shown) to comply with the requirements of ASME Power Piping Code B31.1 and Chemical and Petroleum Piping Code B31.3.
-

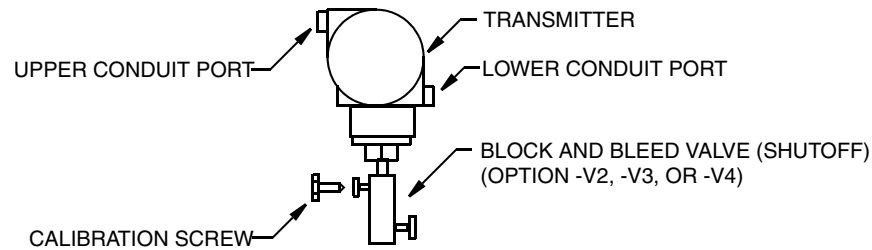

NOTE: Block and Bleed Valve Maximum Pressure
 40 MPa (6000 psi at 38°C) (100°F)
 25 MPa (4000 psi at 250°C) (400°F)
 Calibration Screw Maximum Pressure
 0.7 MPa (100 psi with Poly-Flo Fitting) (F0101ES)

Figure 10. Typical Transmitter Piping

For hot process applications above the operative limits of your transmitter [121°C (250°F) for silicone fill fluid or 82°C (180°F) for fluorinert fill fluid], such as steam, additional piping is required to protect the transmitter from the hot process. See Figure 11. The piping is filled with water or process fluid. Mount the transmitter below the pressure connection at the pipe. Although the transmitter is shown mounted vertically, you can also mount it horizontally unless sediment is present. The calibration tee is not required if a calibration screw is used for field calibrations.

If trapped vapor pockets cannot be tolerated in a liquid service and a horizontal process connection is used, install a pipe elbow and vertically position the transmitter with the housing **below** the process connection.

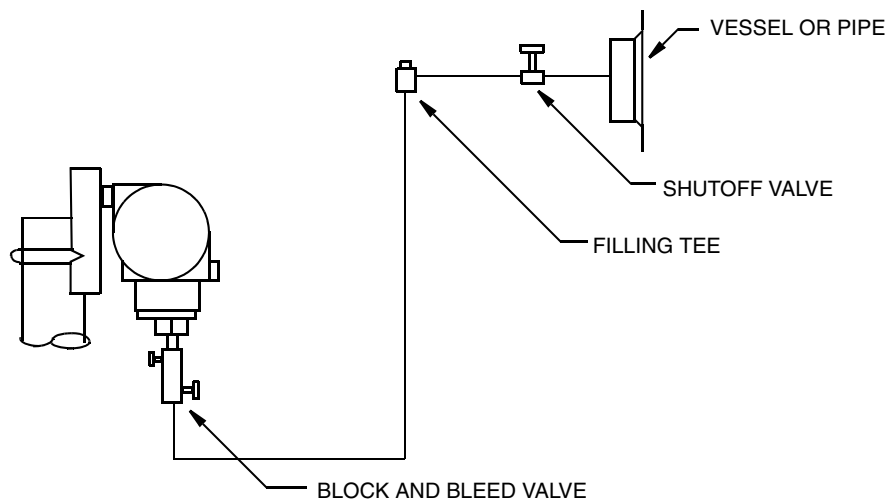

Figure 11. Hot Process Piping

Positioning the Housing

The transmitter housing (topworks) can be rotated up to one full turn in the counterclockwise direction when viewed from above for optimum access to adjustments, display, or conduit

connections. Housings have either an anti-rotation screw or a retention clip that prevent the housing from being rotated beyond a safe depth of housing/sensor thread engagement.

! WARNING

If the electronics housing is removed for maintenance, it must be hand tightened to the bottom of the threads, but not over-tightened upon reassembly. See “Removing and Reinstalling a Housing Assembly” on page 61.

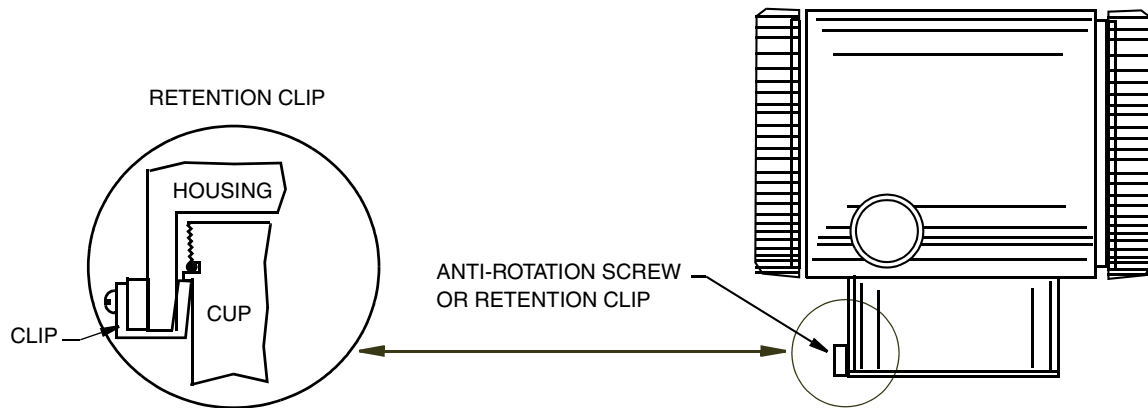

Figure 12. Housing Screw or Clip Location

Positioning the Display

The display (optional in some models) can be rotated within the housing to any of four positions at 90° increments. To do this, grasp the two tabs on the display and rotate it about 10° in a counterclockwise direction. Pull out the display. Ensure that the O-ring is fully seated in its groove in the display housing. Turn the display to the desired position, reinsert it in the electronics module, aligning the tabs on the sides of the assembly, and twist it in the clockwise direction.

! CAUTION

Do **not** turn the display more than 180° in any direction. Doing so could damage its connecting cable.

Setting the Write Protect Jumper

Your transmitter has write protection capability. This means that the external zero, local display, and remote communications can be prevented from writing to the electronics. Write protection is set by moving a jumper that is located in the electronics compartment behind the optional display. To activate write protection, remove the display as described in the previous section, then remove the jumper or move it to the lower position as shown on the exposed label. Replace the display.

Cover Locks

Electronic housing cover locks, shown in Figure 13, are provided as standard with certain agency certifications and as part of the Custody Transfer Lock and Seal option. To lock the covers, unscrew the locking pin until approximately 6 mm (0.25 in) shows, lining up the hole in the pin with the hole in the housing. Insert the seal wire through the two holes, slide the seal onto the wire ends and crimp the seal.

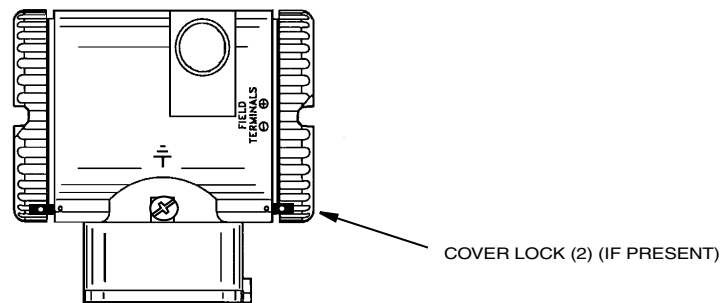

Figure 13. Cover Lock Location

Wiring

The installation and wiring of your transmitter must conform to local code requirements.

— **! WARNING** —

ATEX requires that when the equipment is intended to be used in an explosive atmosphere caused by the presence of combustible dust, cable entry devices and blanking elements shall provide a degree of ingress protection of at least IP6X. They shall be suitable for the conditions of use and correctly installed.

— **NOTE** —

Invensys recommends the use of transient/surge protection in installations prone to high levels of electrical transients and surges.

Accessing Transmitter Field Terminals

For access to the field terminals, thread the cover lock (if present) into the housing to clear the threaded cover and remove the cover from the field terminals compartment as shown in Figure 14. Note that the embossed letters **FIELD TERMINALS** identify the proper compartment.

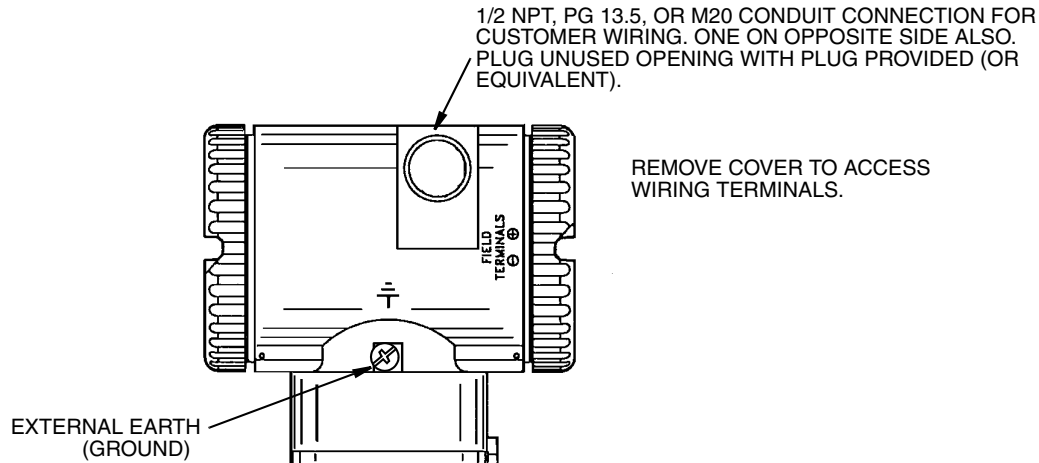

Figure 14. Accessing Field Terminals

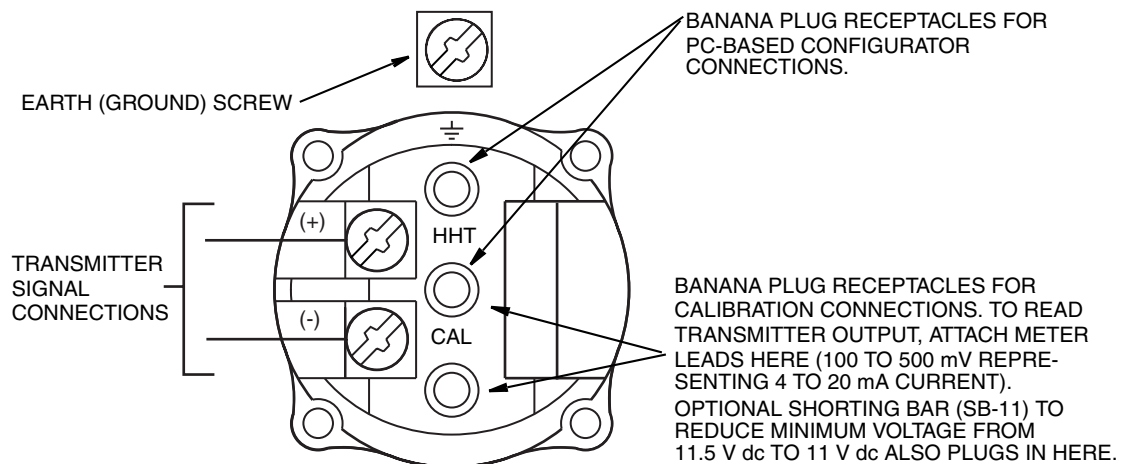

Figure 15. Identification of Field Terminals

Wiring a Transmitter Having a Digital Output Signal

Your transmitter, whether its output signal is configured **DIGITAL** or **4-20 mA**, has a digital output to communicate with an I/A Series system. If configured **DIGITAL**, connect to an FBM 18, 39, 43, 44, or 243. Its digital communications rate is 4800 baud. If configured **4-20 mA**, connect to an FBM 43, 44, or 243. Its digital communications rate is 600 baud.

— **! CAUTION** —

1. All devices attached to an FBM 43 or FBM 44 must be configured for the same output (**DIGITAL** or **4-20 mA**).
2. Make sure that **DEVNAM** parameter is configured the same as the letterbug used for that channel in the I/A Series system, or verify that it is set to its default description, **DevNam**, before installation.

— NOTE

An I/A Series system can also receive an analog signal from a transmitter configured **4-20 mA** and attached to an FBM 1, 4, 201, or 204. However, it cannot communicate digitally with the transmitter using this analog signal.

Transmitter power is supplied by the FBM. The maximum total resistance for each transmitter loop varies with the FBM. The maximum recommended length for field wire is 600 m (2000 ft). However, the maximum total resistance must be taken into consideration. For example, if the maximum total loop resistance allowed is 420 Ω and an intrinsically safe barrier with a resistance of 200 Ω is used, the maximum resistance left for receivers in the loop and wire resistance is 220 Ω .

1. Remove the cover from the transmitter field terminal compartment.
2. Run signal wires (0.50 mm² or 20 AWG, typical) through one of the transmitter conduit connections as shown in Figure 16. Use twisted pair to protect the digital output and/or remote communications from electrical noise. Screened (shielded) cable may be required in some locations.

— NOTE

Do not run transmitter wires in same conduit as mains (ac power) wires.

3. If shielded cable is used, earth (ground) the shield at the field enclosure **only**. Do not ground the shield at the transmitter.
4. Plug unused conduit connection with the 1/2 NPT, PG 13.5 or M20 metal plug provided (or equivalent). To maintain specified explosionproof and dust-ignitionproof protection, plug must engage a **minimum** of five full threads for 1/2 NPT connections; seven full threads for M20 and PG 13.5 connections

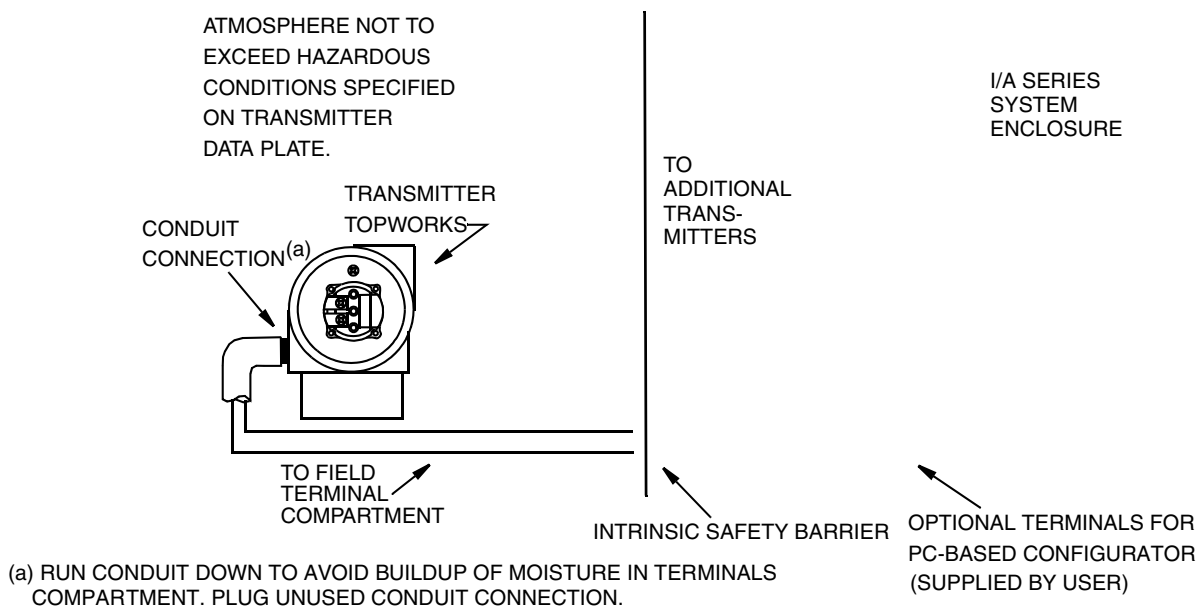

Figure 16. Typical Transmitter Wiring to an I/A Series System

5. Connect an earth (ground) wire to the earth terminal in accordance with local practice.

— **! CAUTION** —

To avoid errors resulting from earth loops or the possibility of short-circuiting groups of instruments in a loop, use only one earth in a loop.

6. Connect the signal wires to the transmitter “+” and “-” terminal connections.
7. The PC-Based Configurator can be connected via banana plugs to the top two receptacles (designated **HHT**) on the terminal block in the field terminal compartment or any other convenient location in the loop (subject to hazardous location restrictions). For example, to communicate with several transmitters from a single location, connect each pair of signal wires to a separate pair of terminals. The PC-Based Configurator can then be easily disconnected from one loop and connected to another.
8. Reinstall the cover onto the housing by rotating it clockwise to seat the O-ring into the housing and then continue to hand tighten until the cover contacts the housing metal-to-metal. If cover locks are present, lock the cover per the procedure described in “Cover Locks” on page 23.
9. To connect the transmitter signal wires to the I/A Series system, Refer to applicable I/A Series system instructions. Note that the type of wire terminations used depends on the type of system enclosure purchased.

Wiring a Transmitter Having a 4 to 20 mA Output Signal

When wiring a transmitter with 4 to 20 mA output signal, the supply voltage and loop load must be within specified limits. The supply output load vs. voltage relationship is:

$R_{MAX} = 47.5 (V - 11.5)$ and is shown in Figure 17.

— **NOTE** —

The relationship when the optional shorting bar is used is:

$R_{MAX} = 46.8 (V - 11)$.

Any combination of supply voltage and loop load resistance in the shaded area can be used. To determine the loop load resistance (transmitter output load), add the series resistance of each component in the loop, excluding the transmitter. The power supply must be capable of supplying 22 mA of loop current.

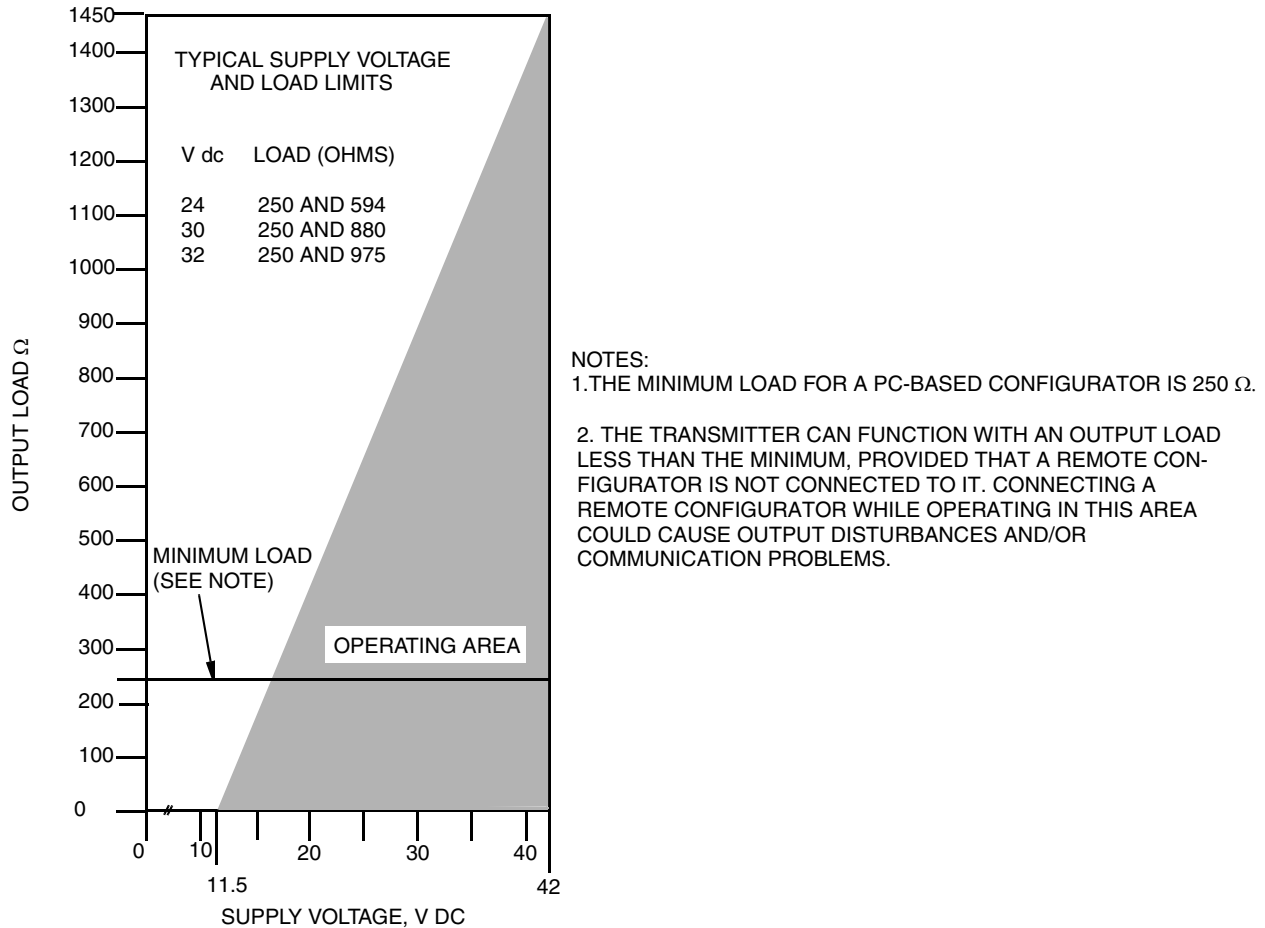

Figure 17. Supply Voltage and Loop Load

Examples:

1. For a loop load resistance of 880 Ω, the supply voltage can be any value from 30 to 42 V dc.
2. For a supply voltage of 24 V dc, the loop load resistance can be any value from 250 to 594 Ω (zero to 594 Ω without an PC-Based Configurator connected to the transmitter).

To wire one or more transmitters to a power supply, proceed with the following steps.

1. Remove the cover from the transmitter field terminals compartment.
2. Run signal wires (0.50 mm² or 20 AWG, typical) through one of the transmitter conduit connections. Use twisted pair to protect the 4 to 20 mA output and/or remote communications from electrical noise. Maximum recommended length for signal wires is 1800 m (6000 ft)

— NOTE

Do not run transmitter wires in same conduit as mains (ac power) wires.

3. If shielded cable is used, earth (ground) the shield at the receiver **only**. Do not ground the shield at the transmitter.

4. Plug unused conduit connection with the 1/2 NPT, PG 13.5, or M20 metal plug provided (or equivalent). To maintain specified explosionproof and dust-ignitionproof protection, plug must engage a **minimum** of five full threads for 1/2 NPT connections; seven full threads for M20 and PG 13.5 connections.
5. Connect an earth (ground) wire to the earth terminal in accordance with local practice.

— **! CAUTION** —

If the signal circuit must be earthed (grounded), it is preferable to do so at the negative terminal of the dc power supply. To avoid errors resulting from earth loops or the possibility of short-circuiting groups of instruments in a loop, there should be only one earth in a loop.

6. Connect the power supply and receiver loop wires to the “+” and “–” terminal connections.
7. Connect receivers (such as controllers, recorders, indicators) in series with power supply and transmitter as shown in Figure 18.
8. Reinstall the cover onto the housing by rotating it clockwise to seat the O-ring into the housing and then continue to hand tighten until the cover contacts the housing metal-to-metal. If cover locks are present, lock the cover per the procedure described in “Cover Locks” on page 23.
9. If wiring additional transmitters to the same power supply, repeat Steps 1 through 8 for each additional transmitter. The setup with multiple transmitters connected to a single power supply is shown in Figure 19.
10. The PC-Based Configurator can be connected in the loop between the transmitter and the power supply as shown in Figures 18 and 19. Note that a minimum of 250 Ω must separate the power supply from the PC-Based Configurator.

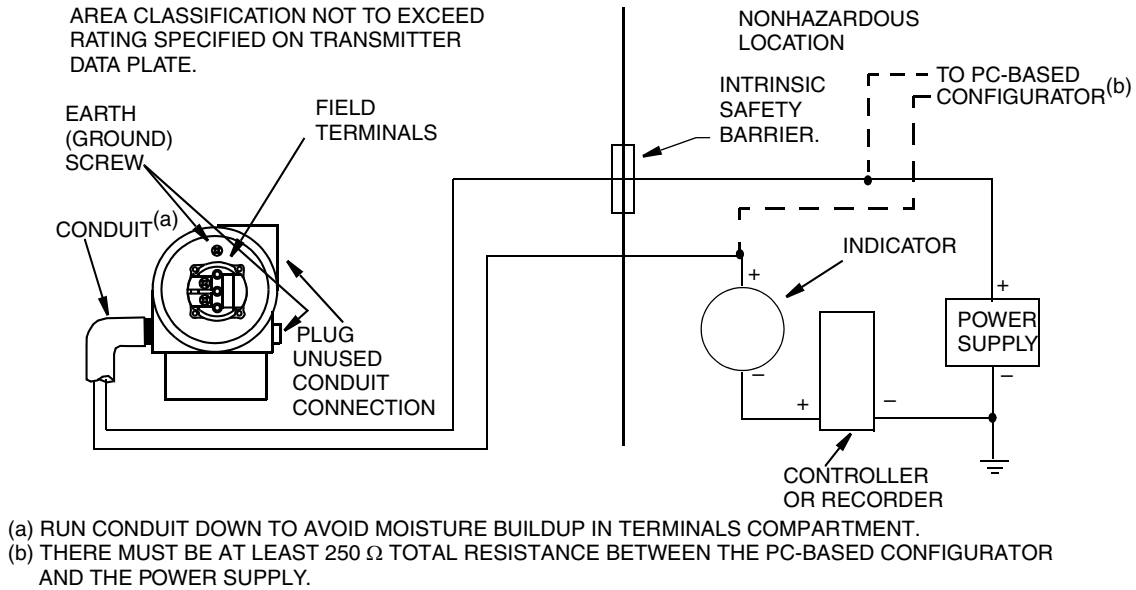

Figure 18. Loop Wiring 4 to 20 mA Output Transmitters

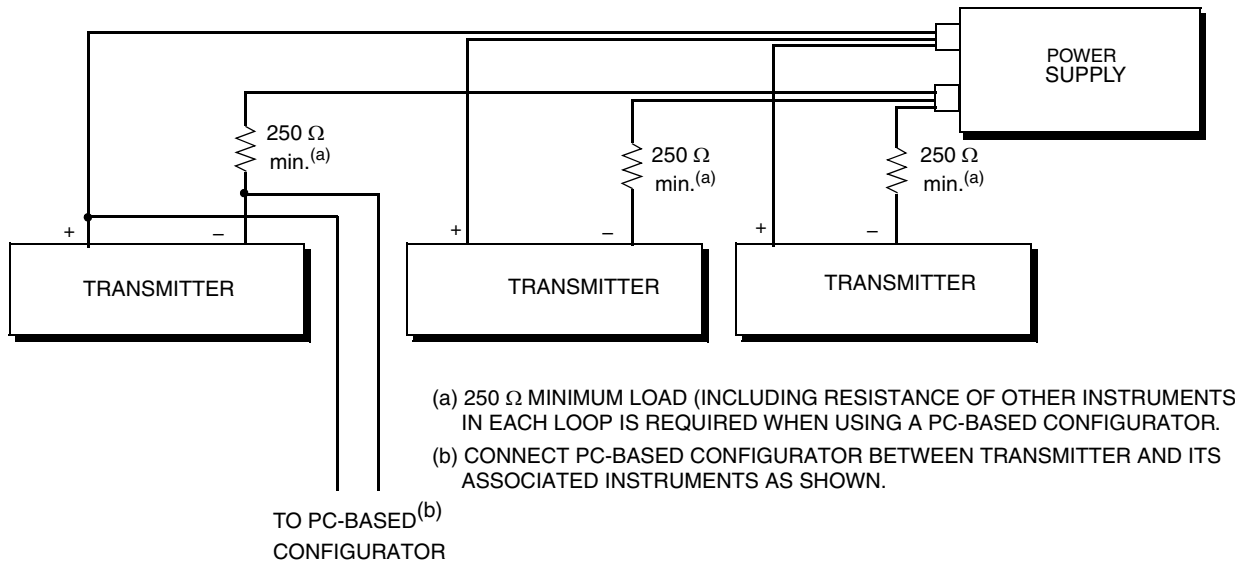

Figure 19. Wiring Several 4 to 20 mA Transmitters to a Common Power Supply

3. Operation Via Local Display

A local display, as shown in Figure 20, has two lines of information. The upper line is a 5-digit numeric display (4-digit when a minus sign is needed); the lower line is a 7-digit alphanumeric display. The display provides local indication of measurement information. The primary (M1) measurement is normally displayed. To view the secondary (M2) measurement, press the **Enter** button while in normal operating mode. Press the **Next** or **Enter** button to return to the primary measurement. If left in M2 display, an M2 message blinks in the lower right of the display. If power to the transmitter is interrupted, the display reverts to the M1 display.

The display also provides a means for performing calibration and configuration, viewing the database, and testing the display via the 2-button keypad. You can access these operations by means of a multi-level menu system. Entry to the Mode Select menu is made (from normal operating mode) by pressing the **Next** button. You can exit this menu, restore your prior calibration or configuration, and return to the normal operating mode at any time by going to **Cancel** and pressing the **Enter** button.

The following items can be selected from this menu: Calibration (**CALIB**), Configuration (**CONFIG**), Viewing the database (**VIEW DB**), and Testing the display (**TST DSP**). The top level structure diagram is shown in Figure 21.

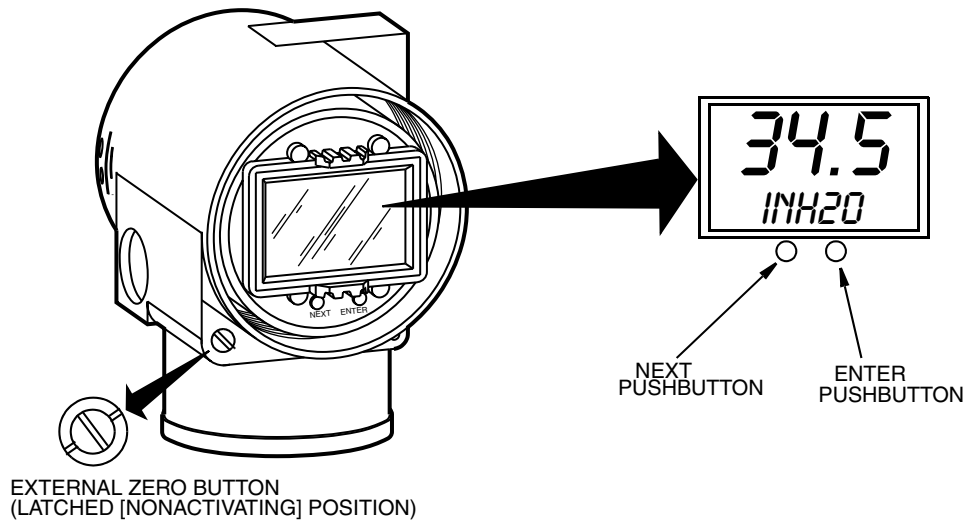

Figure 20. Local Display Module

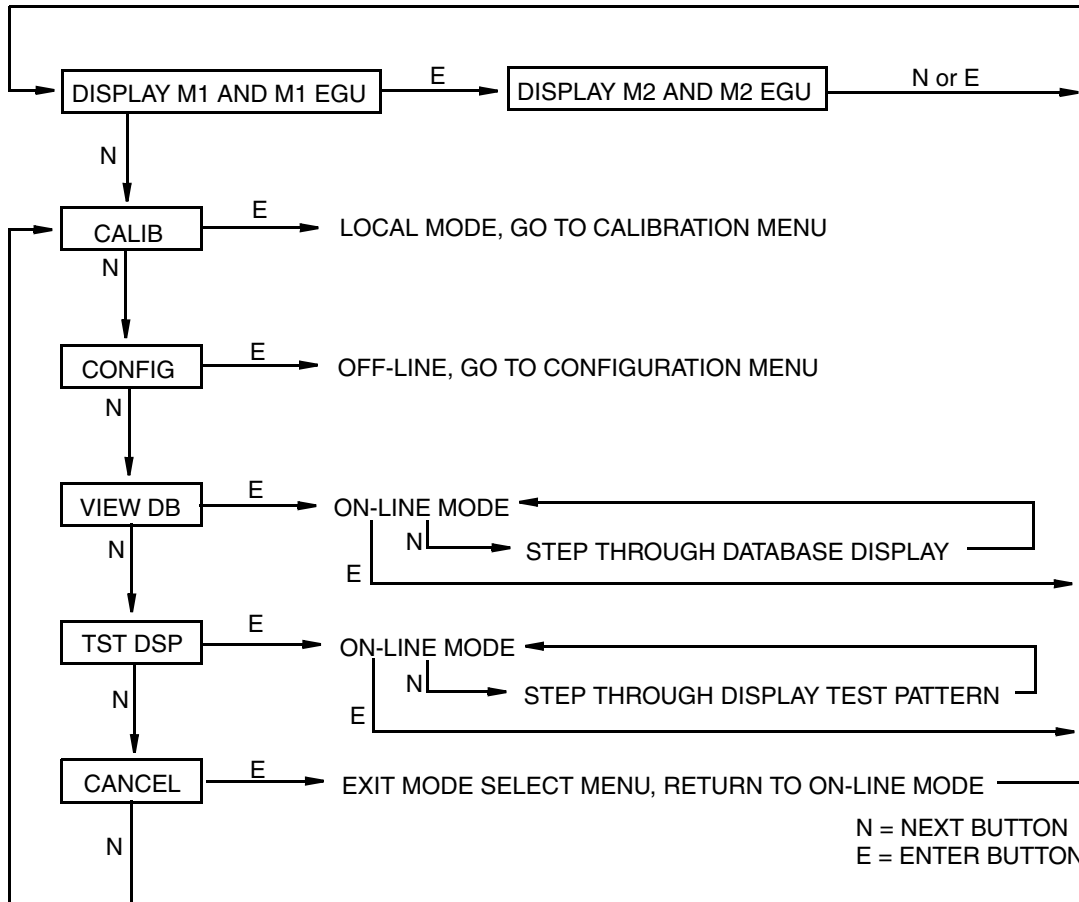

Figure 21. Top Level Structure Diagram

Entering Numerical Values

The general procedure for entering numerical values in Calibration and Configuration is as follows:

1. At the appropriate prompt, press the **Enter** button. The display shows the last (or default) value with the first digit flashing.
2. Use the **Next** button to select the desired first digit, then press the **Enter** button. Your selection is entered and the second digit flashes.
3. Repeat Step 2 until you have created your new value. If the number has less than five characters, use leading or trailing zeros for the remaining spaces. When you have configured the fifth space, the display prompts you to place the decimal point.
4. Move the decimal point with the **Next** button until it is where you want it and press the **Enter** button.

— NOTE

1. The decimal point may not be placed directly after the first digit. For example, you can not enter a value as 1.2300; you must enter it as 01.230.
 2. The decimal position is identified by flashing except at the position after the fifth digit. At that position (representing a whole number), the decimal point is assumed.
-
5. The display advances to the next menu item.

Viewing the Database

You can access the View Database mode by the multi-level menu system described above. Entry to the Mode Select menu is made (from normal operating mode) by pressing the **Next** button. The display reads **CALIB**, the first item on the menu. Press the **Next** button twice to get to the third item on the menu, **VIEW DB**. Acknowledge your choice of this selection by pressing the **Enter** button. The display shows the first item in the database. You can step through the database display by repeated use of the **Next** button. You can abort this procedure at any time by pressing the **Enter** button.

Viewing the Pressure Range

The values of **M1LRV** and **M1 URV** can be viewed in **VIEW DB** as described above. They can also be viewed in the **RERANGE** function in Calibration mode.

Testing the Display

You can access the Test Display mode by the same multi-level menu system that was used to enter Calibration, Configuration, and View Database mode. Entry to the Mode Select menu is made (from normal operating mode) by pressing the **Next** button. The display reads **CALIB**, the first item on the menu. Press the **Next** button three times to get to the fourth item on the menu, **TST DSP**. Acknowledge your choice of this selection by pressing the **Enter** button. The display shows the first test segment pattern. You can step through the five patterns by repeated use of the **Next** button. You can abort the test at any time by pressing the **Enter** button. The five patterns are shown in Figure 22.

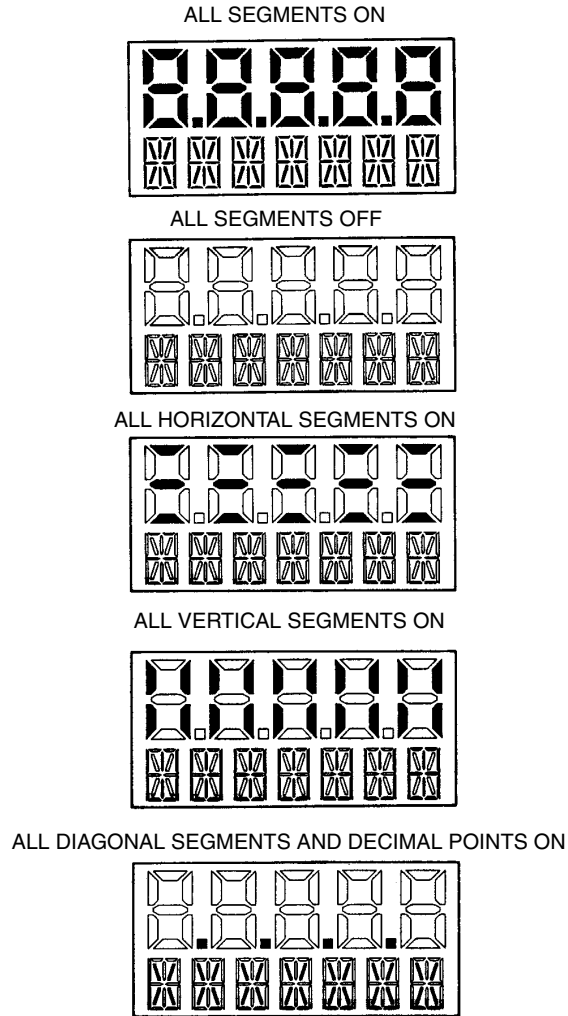

Figure 22. Display Test Segment Patterns

Error Messages

Table 4. Operation Error Messages

Parameter	Condition Tested	Error Message	Action
Normal Operation	Write Protection Enabled	WR PROT	Displays periodically to notify user that unit is in Write Protect.
	Any non-On-line Condition	OFFLINE	Notifies user of a non-On-line condition.
Startup	Database OK or corrupted	INITERR	User should perform SET GDB procedure. See “SET GDB:” on page 56.

4. Calibration

NOTE

1. For best results in applications where high accuracy is required, rezero the transmitter output once it has stabilized at the final operating temperature.
 2. Zero shifts resulting from position effects and/or static pressure effects can be eliminated by rezeroing the transmitter output.
 3. After calibrating transmitters operating with a 4 to 20 mA (or 1 to 5 V dc) output signal, check the underrange and overrange output values to ensure that they extend beyond 4 and 20 mA (or 1 and 5 V dc) respectively.
-

General Calibration Notes

1. Each transmitter is factory characterized over its full rated pressure range. One benefit of this process is that every transmitter can measure any applied pressure within its range limits regardless of the calibrated range. The applied pressure is measured and converted into an internal digital value of pressure. This digital value of pressure is always available whether the transmitter is calibrated or not. Calibration assures that the transmitter rated accuracy is achieved over the calibrated range.
2. The internal digital value of pressure can be displayed on the optional local display, transmitted digitally, and converted to a 4 to 20 mA analog output signal.
3. Each transmitter is factory calibrated to either a specified or a default calibrated range. This calibration optimizes the accuracy of the internal digital value of pressure over that range. If no range is specified, the default range is zero to the sensor upper range limit (URL).
4. The transmitter database has configurable values for both lower range value (LRV) and upper range value (URV). These values are used for two functions.
 - a. Defining the Calibrated Range When Using Local Pushbuttons for Calibration:
 - ◆ When either **CAL LRV** or **CAL URV** is initiated from the local pushbuttons, the transmitter expects that the pressure applied at the time the button is pressed is equal to the LRV or URV value respectively.
 - ◆ This function trims the internal digital value of pressure; that is, it performs a calibration based on the application of accurate pressures equal to the values entered for LRV and URV in the transmitter database.
 - ◆ This function also sets the 4 and 20 mA output points; that is, the 4 and 20 mA points correspond to the values of LRV and URV in the database.
 - ◆ The value of LRV can be larger than the value of URV.
 - b. Reranging Without the Application of Pressure:
 - ◆ Since the transmitter continually determines an internal digital value of the measured pressure from the lower range limit (LRL) to the upper range limit

(URL), the 4 and 20 mA output points can be assigned to any pressure values (within the span and range limits) without application of pressure.

- ◆ The reranging function is accomplished by entering new database values for LRV and URV.
 - ◆ Reranging does not affect the calibration of the transmitter; that is, it does not affect the optimization of the internal digital value of pressure over a specific calibrated range.
 - ◆ If the reranged LRV and URV are not within the calibrated range, the measured values may not be as accurate as when they are within the calibrated range.
5. When the optional local display is used, the internal digital value of pressure is sent directly to the indicator.
- ◆ The display can show any measured pressure in selected units regardless of the calibrated range and the values of LRV and URV (within the limits of the transmitter and display).
 - ◆ If the measured pressure is outside the range established by the LRV and URV values in the database, the display shows the measurement but also continually blinks to indicate that the measurement is out of range. The mA current signal is saturated at either the low or high overrange limit respectively but the display continually shows the pressure.
6. When configured for 4 to 20 mA output, the internal digital value of pressure is converted to an analog current signal.
- ◆ The transmitter sets the output at 4 mA for the LRV and 20 mA for the URV.
 - ◆ There is an independent trim on the digital-to-analog conversion stage. This trim allows for slight adjustment of the 4 and 20 mA outputs. This compensates for any slight difference that exists between the transmitter mA output and an external reference device which is measuring the current.
 - ◆ The mA trim does not affect the calibration or the reranging of the transmitter and does not affect the internal digital value of pressure or the transmission or display of measured pressure.
 - ◆ The mA trim can be done with or without pressure applied to the transmitter.
7. Zeroing from the local display pushbuttons does not affect the span.

When the transmitter is zeroed to compensate for installed position effect, the transmitter can have either LRV pressure applied (**CAL LRV**) or zero pressure applied (**CAL AT0**). If the range is zero-based, either method produces the same result. However, if the range is not zero-based, it is advantageous to have both methods available.

For example, consider a pressure transmitter having a range of 50 to 100 psig. If it is not feasible to vent the transmitter to atmosphere for zeroing, it can be zeroed while the LRV pressure of 50 psi is applied by using the **CAL LRV** function. On the other hand, if the transmitter has been installed but there is no pressure in the process line yet, it can be zeroed while open to atmosphere by using the **CAL AT0** function.

- a. Zeroing with LRV Pressure Applied (**CAL LRV**):
- ◆ Before using this zeroing function, apply a pressure to the transmitter equal to the value of LRV stored in the transmitter database.
 - ◆ When you zero the transmitter, the internal digital value of the pressure is trimmed to be equal to the value of LRV stored in the database and the mA output set to 4 mA.
 - ◆ If zeroing is done when the applied pressure is different from the LRV pressure value in the database, the internal digital value of pressure is biased by the difference in the values but the output is still set at 4 mA.
 - ◆ The **CAL LRV** (and **CAL URV**) function should be used when calibrating a transmitter for a specific range with known input pressures applied for the LRV and URV.
- b. Zeroing a Gauge Pressure Transmitter with Zero Pressure Applied (**CAL AT0**):

— **NOTE** —

Do **not** use the **CAL AT0** function with an absolute pressure transmitter. If an absolute pressure transmitter is vented to atmosphere, it does **not** have zero pressure applied but instead has the barometric pressure (approximately 14.7 psia) applied.

- ◆ Make sure that the applied pressure is at zero. This means venting the transmitter to atmosphere.
 - ◆ When you zero the transmitter, the internal digital value of the pressure is trimmed to be equal to zero and the mA output set to an appropriate value such that the mA output is a normal 4 mA when the LRV pressure is applied later.
- c. Zeroing an Absolute Pressure Transmitter
- To zero an absolute pressure transmitter, the LRV can be temporarily set to the barometric pressure and a CAL LRV function performed with the transmitter vented to atmosphere. Then, the LRV can be set back to the proper value.

Calibration Setup

The following sections show setups for field or bench calibration. Use test equipment that is at least three times as accurate as the desired accuracy of the transmitter.

— **NOTE** —

It is not necessary to set up calibration equipment to re-range the transmitter to a different range. The transmitter can be accurately re-ranged by simply changing the lower range value and the upper range value, which are stored in the transmitter database.

Setup of Electronic Equipment

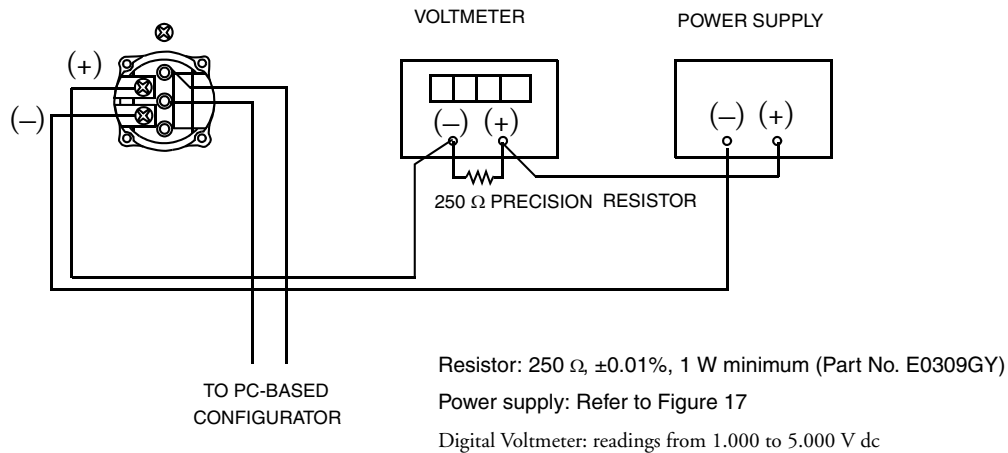
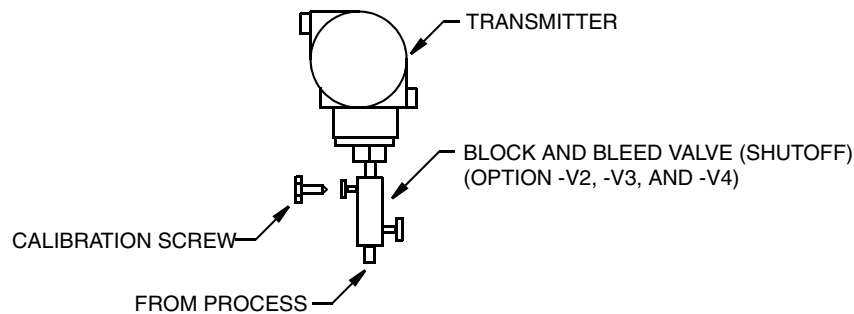

Figure 23. 4 to 20 mA Output Calibration Setup of Electronic Equipment

Field Calibration Setup

Field calibration is performed without disconnecting the process piping. This is only possible if the transmitter is piped as shown in Figure 24.



NOTE: Block and Bleed Valve Maximum Pressure
 40 MPa (6000 psi at 38°C (100°F))
 25 MPa (4000 psi at 250°C (400°F))
 Calibration Screw Maximum Pressure
 0.7 MPa (100 psi with Poly-Flo Fitting (F0101ES))

Figure 24. Transmitter Piping

If the transmitter is to be removed from the process for calibration, refer to “Bench Calibration Setup” below.

An adjustable air supply and a pressure measuring device are required. For example, a dead weight tester or an adjustable clean air supply and pressure gauge can be used.

Bench Calibration Setup

The bench calibration setup requires disconnecting the process piping. For calibration setup without disconnecting the process piping, refer to “Field Calibration Setup” above.

The bench calibration setup is shown in Figure 25. If calibrating the output signal, also connect equipment as shown in Figure 23.

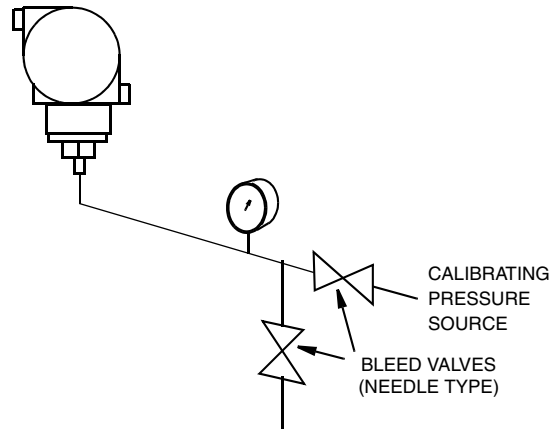

Figure 25. Bench Calibration Setup

Calibration Using a PC20

To calibrate the transmitter using a PC20 Configurator, follow the procedure in MI 020-495.

Calibration Using a PC50

To calibrate the transmitter using a PC50 Configurator, follow the procedure in MI 020-501 and MI 020-504.

Calibration Using the Optional Local Display

To access the Calibration mode (from normal operating mode), press the **Next** button. The display reads **CALIB**, the first item on the menu. Acknowledge your choice of this selection by pressing the **Enter** button. The display shows the first item in the Calibration menu.

— **NOTE** —

1. 1. During calibration, a single change could affect several parameters. For this reason, if an entry is entered in error, re-examine the entire database or use the **Cancel** feature to restore the transmitter to its starting configuration and begin again.
2. 2. During adjustment of 4 and 20 mA in the Calibration menu, the milliampere output does not reflect live measurement values.
3. 3. During calibration operations, the I/A Series system identifies all transmitter measurements as **BAD** because the transmitter is not in the on-line mode.

4. 4. If calibration has been configured as password protected, you are asked to enter the password before you can proceed.
5. 5. If your transmitter is write protected, you cannot write your calibration to the electronics without disabling this feature.

Table 5. Calibration Menu

Item	Description
CAL AT0 ^(a)	Calibrate at zero pressure.
CAL LRV	Calibrate with pressure at 0% of transmitter range (LRV).
CAL URV	Calibrate with pressure at 100% of transmitter range (URV).
ADJ 4mA	Adjust nominal 4 mA output (D/A converter trim).
ADJ20mA	Adjust nominal 20 mA output (D/A converter trim).
RERANGE	Set primary upper and lower range values.
CALDATE	Enter the calibration date.
ADJ 4mA causes the following four submenus.	
A 4mAΔΔ	Increase 4 mA output by large step.
A 4mA∇∇	Decrease 4 mA output by large step.
A 4mAΔ	Increase 4 mA output by small step.
A 4mA∇	Decrease 4 mA output by small step.
ADJ 20mA causes the following four submenus.	
A 20mAΔΔ	Increase 20 mA output by large step.
A 20mA∇∇	Decrease 20 mA output by large step.
A 20mAΔ	Increase 20 mA output by small step.
A 20mA∇	Decrease 20 mA output by small step.
RERANGE causes the following two submenus.	
M1 URV	Set upper range value.
M1 LRV	Set lower range value.

(a)Function not applicable to absolute pressure transmitters.

— **NOTE** —

It is not necessary to use the **ADJ4mA** or **ADJ20mA** menu selections unless there is a plant requirement to make the 4 and 20 mA output values exactly match readings on certain plant calibration equipment and the **CAL LRV** and **CAL URV** operations result in a small but unacceptable difference between the transmitter mA output and the test equipment mA readout values.

Proceed to calibrate your transmitter by using the **Next** button to select your item and the **Enter** button to specify your selection per Figures 26 and 27. At any point in the calibration you can **Cancel**, restore your prior calibration and return to the on-line mode or **Save** your new calibration.

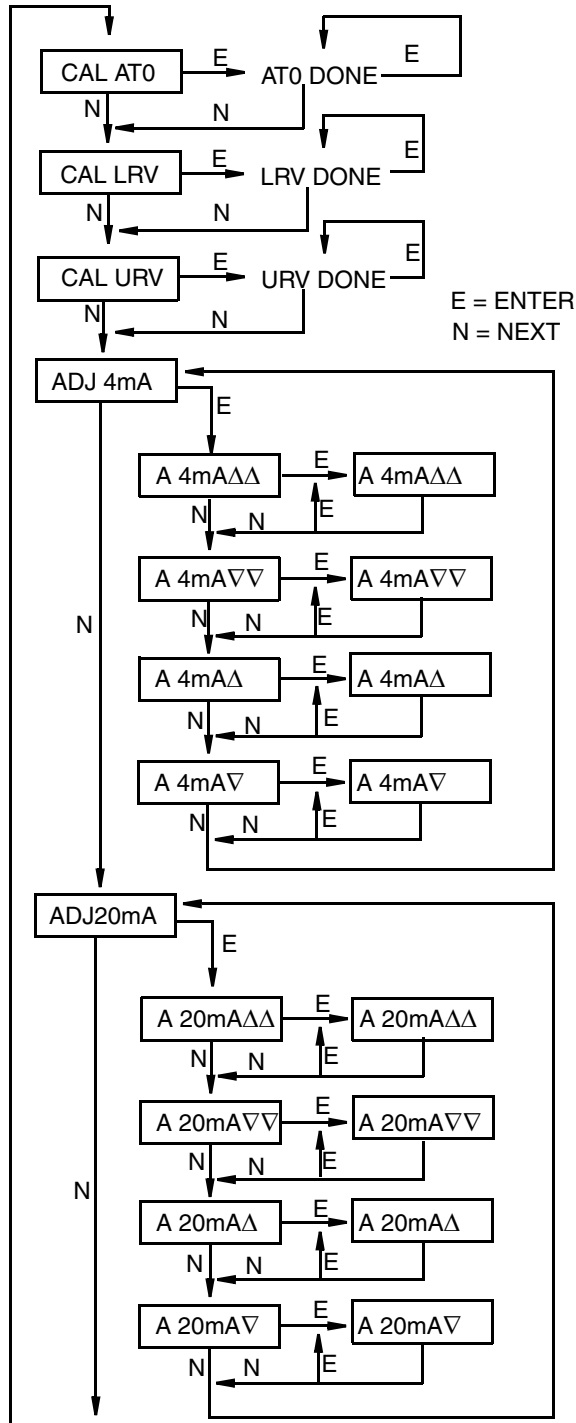

RERANGE
(continued on next
figure)

CAL AT0: To set or reset the zero point at zero pressure, apply zero pressure to the transmitter and, at display of **CAL AT0**, press **Enter**. This can be done whether LRV is zero or not. Completion is indicated by the display **AT0 Done**.

CAL LRV: To set or reset 0% of range input, apply pressure to the transmitter equal to the lower range value (LRV) in the transmitter database and, at display of **CAL LRV**, press **Enter**. Completion is indicated by the display **LRV Done**.

CAL URV: To set or reset 100% of range input, apply pressure to the transmitter equal to the upper range value (URV) in the transmitter database and, at display of **CAL URV**, press **Enter**. Completion is indicated by the display **URV Done**.

ADJ4mA: If you configured your transmitter operating mode as 4 to 20 mA, you can adjust the 4 mA output by going to **ADJ4mA** using the **Next** button and press **Enter**. This menu item is bypassed if you configured your transmitter operating mode as digital.

To increase the 4 mA output by a large (0.025 mA) step, press **Enter** at the display **A 4mAΔΔ**. To decrease it by a large step, go to the display **A 4mA∇∇** by pressing the **Next** button and then **Enter**. To increase it by a

Figure 26. Calibration Structure Diagram

(continued from previous figure)

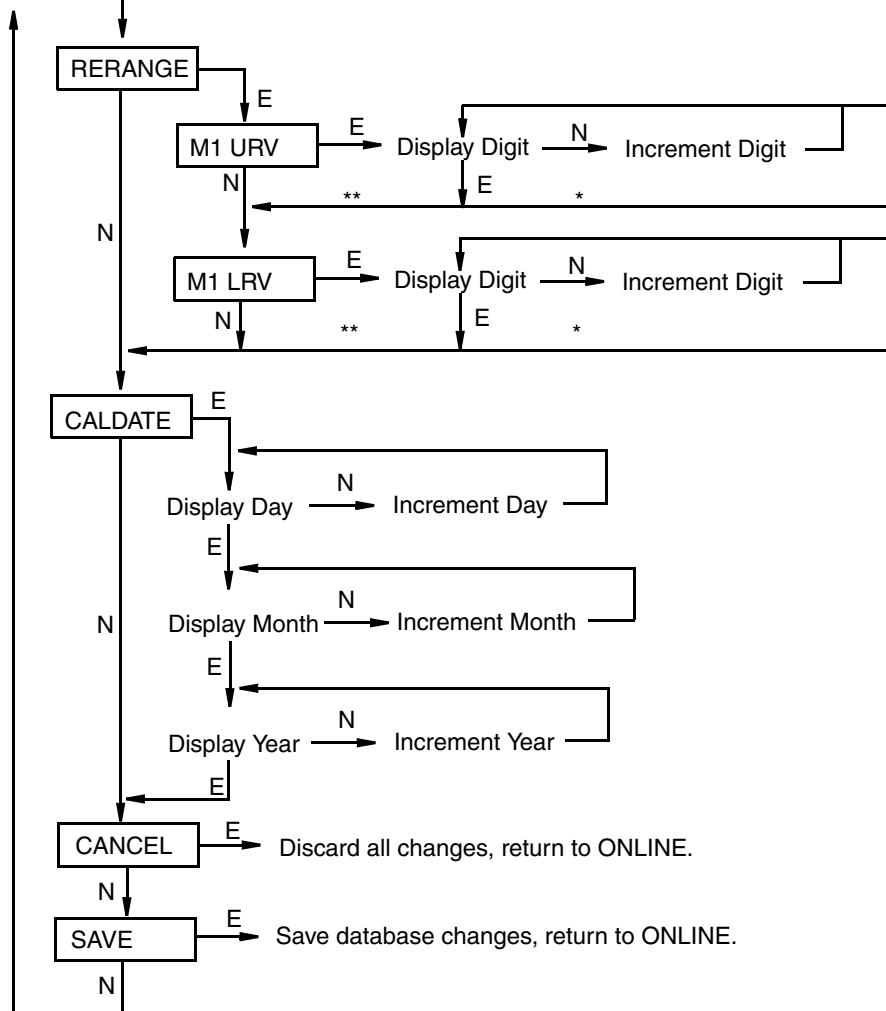

*If character is not the last position on the display line, advances to next character.

**If character is the last position on the display line, advances to next menu item.

NOTE: Commentary about this diagram immediately follows.

Figure 27. Calibration Structure Diagram (Continued)

Commentary on Figure 27

RERANGE:

To adjust 100% and 0% range values, go to **Rerange** with the **Next** button and press **Enter**. You can then adjust **M1 URV** and/or **M1 LRV** in the following two submenus.

M1 URV:

To edit the upper range value, press **Enter** at the prompt **M1 URV**.

M1 LRV:

Similar to M1URV immediately above.

CALDATE:

This is not a required entry but can be used for recordkeeping or plant maintenance purposes. To edit the calibration date, go to **CALDATE** with the **Next** button and press **Enter**. You then can change the day, month, and year. The display shows the last date with the day flashing. Use the **Next** button to step through the menu of digits to select the desired day, then press **Enter**. Repeat this process for the month and year.

Zero Adjustment Using External Zero Button

An external zero adjustment mechanism in the electronics housing allows calibration at zero pressure (the **CAL AT0** function) or at the lower range value pressure (the **CAL LRV** function) without removing the electronics compartment cover. The mechanism is magnetically activated through the housing wall to prevent moisture from entering the enclosure.

To use this feature:

1. Unlatch the external zero button by turning it 90° in a counterclockwise direction so that the screwdriver slot lines up with the two holes in the face of the adjacent part. Do **not** push the button in with the screwdriver while doing this.
2. To set or reset the zero point at zero pressure, apply zero pressure to the transmitter and press the external zero button until the display reads **CAL AT0**. Release the button. The display reads **CAL WAIT** and then **RESET** (calibration is complete).

To set or reset the 0% of range input, apply the lower range value (LRV) pressure to the transmitter and press and hold the external zero button until the display reads **CAL LRV** (it reads **CAL AT0** first). Release the button. The display reads **CAL WAIT** and then **RESET** (calibration is complete).

— **NOTE** —

If the optional display is not present, the same functions can be accomplished by depending on the length of time the external zero button is depressed. Press and hold the button for 1 to 3 seconds for **CAL AT0** or for 5 or more seconds for **CAL LRV**. Therefore, if your LRV is zero, just depress the button for a few seconds. However, if your LRV is not zero, use **caution** when using the external zero button without the optional display because you must rely strictly on the length of time the button is depressed to differentiate between **CAL AT0** and **CAL LRV**.

3. Other possible messages are: **DISABLD** if **EX ZERO** is configured **EXZ DIS** and **IGNORED** if the transmitter is not in the on-line mode. **NA/AP** is displayed if **CAL AT0** is performed on an Absolute Pressure Transmitter (IAP10).
4. If additional rezeroing is required after Steps 1 and 2 have been accomplished repeat Step 2.
5. Relatch the external zero button by turning it 90° in a clockwise direction to prevent accidental pressing of the button. Do **not** push the button in with the screwdriver while doing this.

Error Messages

Table 6. Calibration Error Messages

Parameter	Condition Tested	Error Message	User Action
Password Protection	Password	BAD PWD	Bad password entered, use another.
Write Protection	Write protection enabled	REJECT	Displays when user attempts an action that is write protected.
ZERO	Internal offset too large	BADZERO	Check applied pressure, configured M1 LRV and configured M1 EOFF .
	Completion of data collection	CALWAIT	Displayed while data is collected for calibration.
SPAN	Slope too large or too small	BADSPAN	Check applied pressure, configured M1 LRV and configured M1 EFAC .
	Completion of data collection	CALWAIT	Displayed while data is collected for calibration.
M1 URV	M1URV > max pressure in EGU	URV>FMX	Entered pressure is greater than maximum rated pressure of transmitter. Check entry. Verify EGUs.
	M1URV < min pressure in EGU	URV<FMN	Entered pressure is less than minimum rated pressure of transmitter. Check entry. Verify EGUs.
	M1 URV = M1 LRV	LRV=URV	Cannot set span to 0. Check entry. Check M1 LRV .
	M1 turndown exceeds limit	BADTDWN	Check entry. Check M1 LRV .
M1 LRV	M1LRV > max pressure in EGU	LRV>FMX	Entered pressure is greater than maximum rated pressure of transmitter. Check entry. Verify EGUs.
	M1LRV < min pressure in EGU	LRV<FMN	Entered pressure is less than minimum rated pressure of transmitter. Check entry. Verify EGUs.
	M1 URV = M1 LRV	LRV=URV	Cannot set span to 0. check entry. Check M1 URV .
	M1 turndown exceeds limit	BADTDWN	Check entry. Check M1 URV .

5. Configuration

Configurable Parameters

Table 7 lists all the configurable parameters and the factory default for the IAP10-D and IGP10-D Transmitters. The factory default values have been customized if the transmitter was ordered with optional feature -C1 or -C2. The table also shows which parameters are configurable with the integral vs. remote configurators.

Table 7. Configurable Parameters

Parameter	Capability	Factory Default	Configurable with		Application Requirement
			Integ. Indic.	Remote Config.	
Descriptors					
Tag Number	12 characters max	Tag Number	No	Yes	
Tag Name	14 characters max	Tag Name	No	Yes	
Location	14 characters max	Location	No	Yes	
Device Name	6 characters max	DevNam	Yes	Yes	
Input					
Calibrated Range	LRV to URV in units listed in (a) below	See (a) below when not specified per S.O.	Yes	Yes	
Output					
Output	4 to 20 mA/Digital	4 to 20 mA	Yes	Yes	
Measurement #1 Mode	Linear ^(b)	Linear	Yes	Yes	
Measurement #1 Units	Menu of common pressure units in (c) below or custom units	Units of Calibrated Range	Yes	Yes	
Measurement #1 URV	Primary URV	Same as Calibrated Range	Yes	Yes	
Measurement #1 LRV	Primary LRV	Same as Calibrated Range	Yes	Yes	
Measurement #2 Mode	Linear ^(b)	Linear	Yes	Yes	
Measurement #2 Units	Menu of common pressure units in (c) below or custom units	Units of Calibrated Range	Yes	Yes	
Measurement #2 URV	Secondary URV	Same as Calibrated Range	Yes	Yes	

Table 7. Configurable Parameters (Continued)

Parameter	Capability	Factory Default	Configurable with		Application Requirement
			Integ. Indic.	Remote Config.	
Measurement #2 LRV	Secondary LRV	Same as Calibrated Range	Yes	Yes	
Swap	Exchange Meas. #1 and #2 units.	No	No	Yes	
Other					
Damping	0 to 32 seconds	None	Yes	Yes	
Fail-safe (mA output only)	Fail mode output - high or low	High	Yes	Yes	
Off-line (mA output only)	Off-line output - last value or user set from 3.75 to 21 mA	User set at 4 mA	Yes	No	
Temp Fail Mode	Fail or continue if temp failure occurs	Continue	No	Yes	
Enable Passwords	No password, Configuration only locked, or Calibration and configuration locked	No Password	Yes	No	
External Zero	Enable or Disable	Enable	Yes	Yes	

(a) Span Code C: 0 to 30 psi; Span Code D: 0 to 300 psi; Span Code E: 0 to 3000 psi; Span Code F: 0 to 6000; Span Code G: 0 to 15000; Span Code H: 0 to 30000i

(b) Square root mode is not applicable to absolute and gauge pressure measurement.

(c) psig, psia, inHg, ftH₂O, inH₂O, atm, bar, mbar, MPa, kPa, Pa, kg/cm², g/cm², dy/cm², cmHg, mmHg, torr, cmH₂O, mmH₂O

Configuration Using a PC20

To configure the transmitter using a PC20 Configurator, follow the procedure in MI 020-495.

Configuration Using a PC50

To configure the transmitter using a PC50 Configurator, follow the procedure in MI 020-501 and MI 020-504.

Configuration Using the Optional Local Display

You can access the Configuration mode by the same multi-level menu system that was used to enter Calibration mode. Entry to the Mode Select menu is made (from normal operating mode) by pressing the **Next** button. The display reads **CALIB**, the first item on the menu. Press the **Next** button again to get to the second item on the menu, **CONFIG**. Acknowledge your choice of this selection by pressing the **Enter** button. The display shows the first item in the Configuration

menu. You can then configure items shown in Table 8. The standard factory default configuration is also given in this table.

The standard factory default configuration is not used if either custom configuration option (-C1 or -C2) has been specified. Option -C1 changes only the **IT MODE** from **4 to 20 mA** to **DIGITAL**. Option -C2 is a full factory configuration of all parameters to the user's specifications.

— **NOTE** —

1. 1. You can configure most parameters using the local display. However, for more complete configuration capability, use a PC-Based Configurator.
 2. 2. During configuration, a single change could affect several parameters. For this reason, if an entry is entered in error, re-examine the entire database or use the **Cancel** feature to restore the transmitter to its starting configuration and begin again.
 3. 3. In the Configuration menu, the milliampere output does not reflect live measurement values.
 4. 4. During configuration operations, the I/A Series system identifies all transmitter measurements as **BAD** because the transmitter is not in the on-line mode.
 5. 5. If configuration has been password protected, you are asked to enter the password before you can proceed.
 6. 6. If your transmitter is write protected, you cannot write your configuration to the electronics without disabling this feature.
-

Table 8. Configuration Menu

Item	Description	Initial Factory Configuration
IT MODE	4 to 20 mA or digital mode	4 to 20 mA
DevName	Device Name; 6 characters maximum	DevNam
EX ZERO ^(a)	External Zero: enable or disable	Enable ^(b)
OUT DIR	4 to 20 mA Output: forward or reverse	Forward
OUTFAIL	4 to 20 mA Output: fail mode output: low or high	High
OFFL MA	4 to 20 mA Output in off-line mode: last or user set	USER MA
USER MA	Off-line mA value; between 3.75 and 21 mA	4 mA
DAMPING	Damping: none, 1/4, 1/2, 1, 2, 4, 8, 16, or 32 seconds	None
M1 MODE	Output: linear or type of square root ^(c)	Linear
M1 EGU	User-Defined Engineering Units	inH ₂ O or psi
PRESS U	Selection of Pressure Units from predefined list	- - -
CUSTM U	User-Defined Engineering Units	- - -
M1 LBL	Engineering Units Label (6 characters maximum)	- - -
M1EFAC	Engineering Unit Factor (for custom units)	- - -
M1EOFF	Engineering Unit Offset (for custom units)	- - -

Table 8. Configuration Menu (Continued)

Item	Description	Initial Factory Configuration
RERANGE	Adjustment of 100% and 0% range values	---
M1 URV	Primary Upper Range Value	URL
M1 LRV	Primary Lower Range Value	0
M2 MODE	Output: linear or type of square root ^(c)	Linear
M2 EGU	User-Defined Engineering Units	Same as M1 EGU
PRESS U	Selection of Units from predefined list	---
CUSTM U	User-Defined Engineering Units	---
M2 LBL	Engineering Units (6 characters maximum)	---
M2EFAC	Engineering Unit Factor (for custom units)	---
M2EOFF	Engineering Unit Offset (for custom units)	---
CALDATE	Calibration Date	---
ENA PWD	Enable password; no password, configuration only, or configuration and calibration	NO PWDS
CFG PWD	User set configuration password (six characters)	---
CAL PWD	User set calibration password (six characters)	---

(a)Applies only if transmitter contains External Zero option.

(b)Enable if optional external zero supplied; disable if not supplied.

(c)Square root is not applicable to absolute pressure and gauge pressure measurement.

Proceed to configure your transmitter by using the **Next** button to select your item and the **Enter** button to specify your selection per the following figures. At any point in the configuration you can **Cancel** your changes and return to the on-line mode, or **Save** your changes.

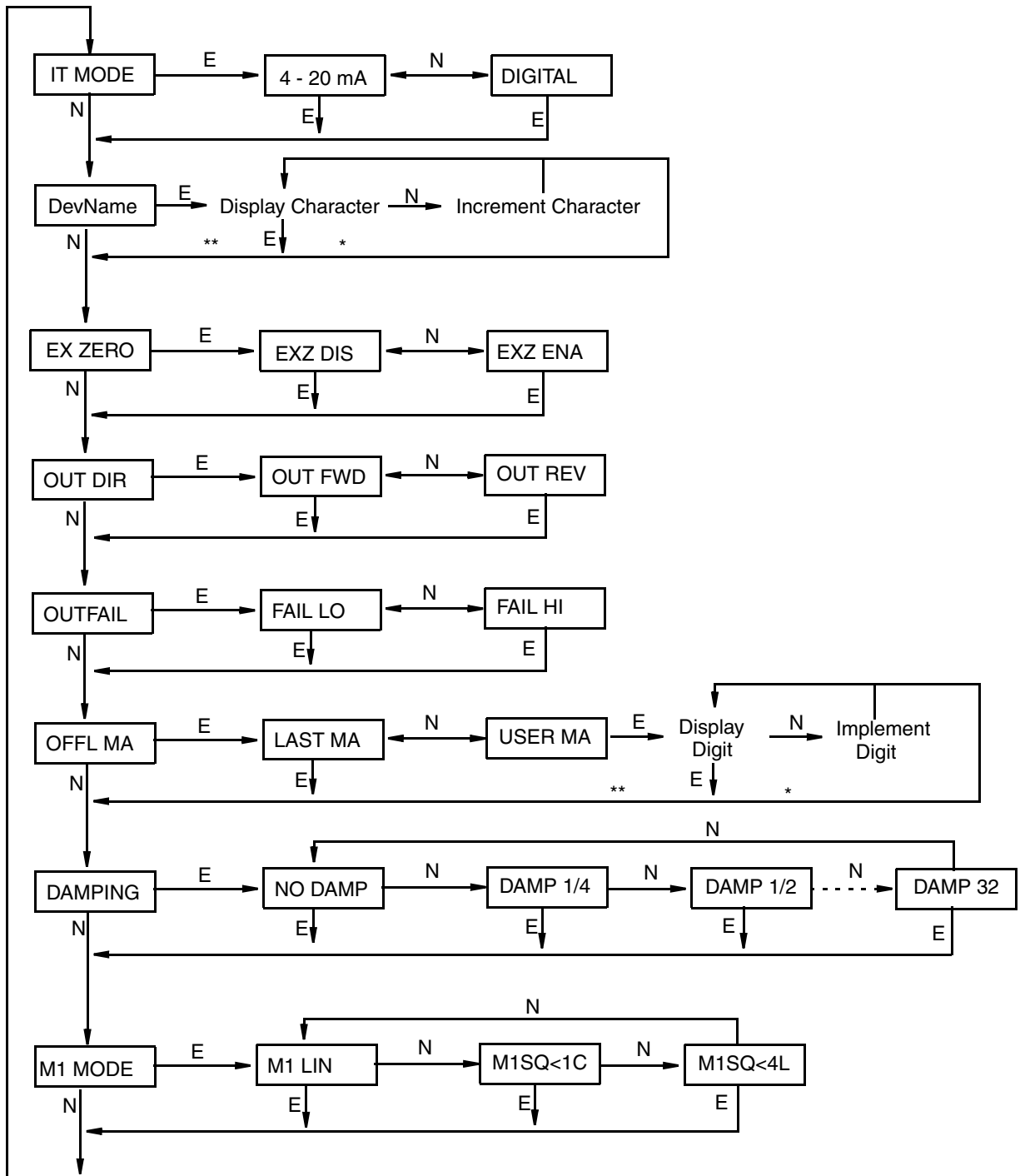

M1 EGU

(continued on next figure)

- *If character is not the last position on the display line, advances to next character.
- **If character is the last position on the display line, advances to next menu item.

Figure 28. Configuration Structure Diagram

(continued from previous figure)

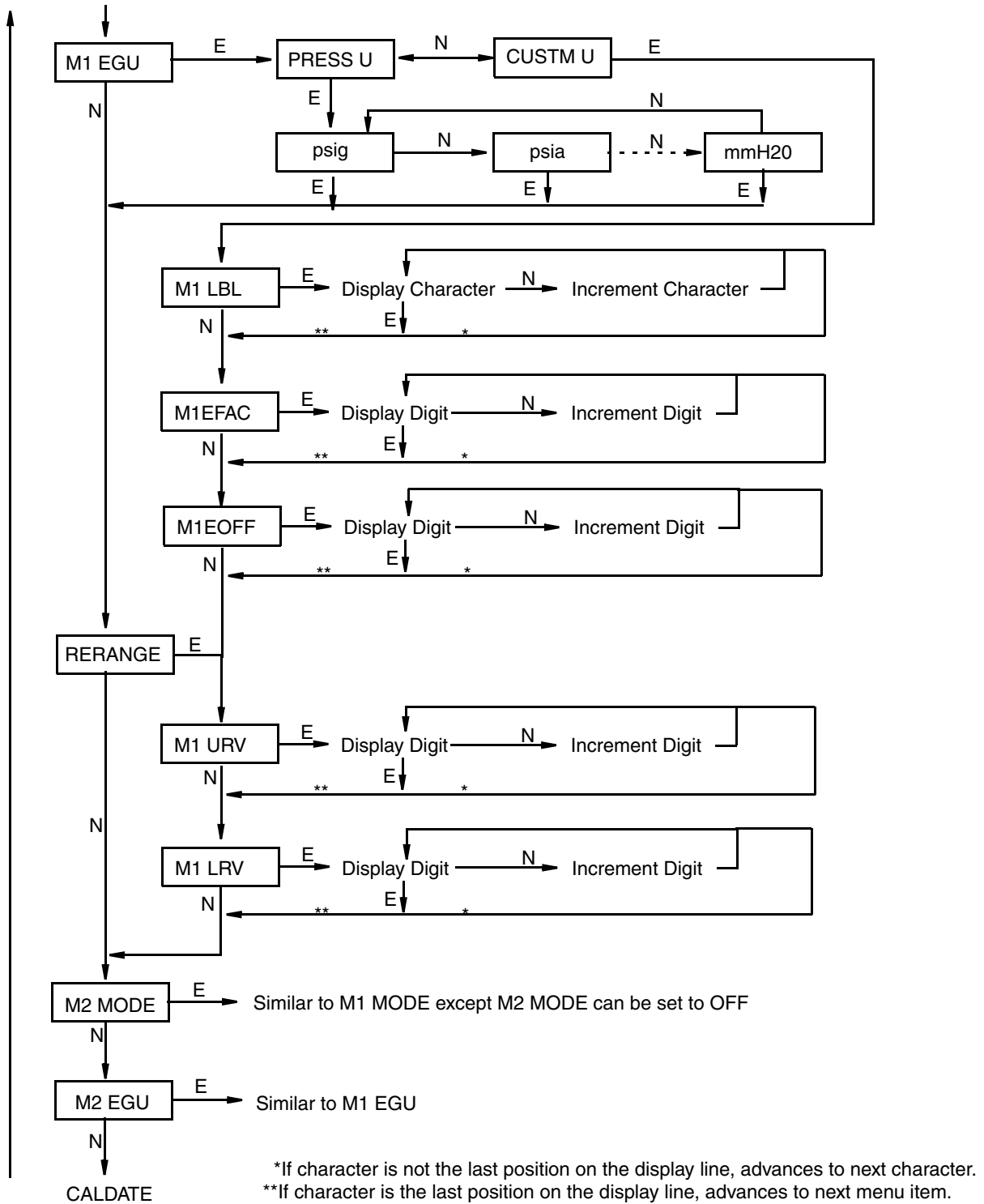

(continued on next figure)

Figure 29. Configuration Structure Diagram (Continued)

(continued from previous figure)

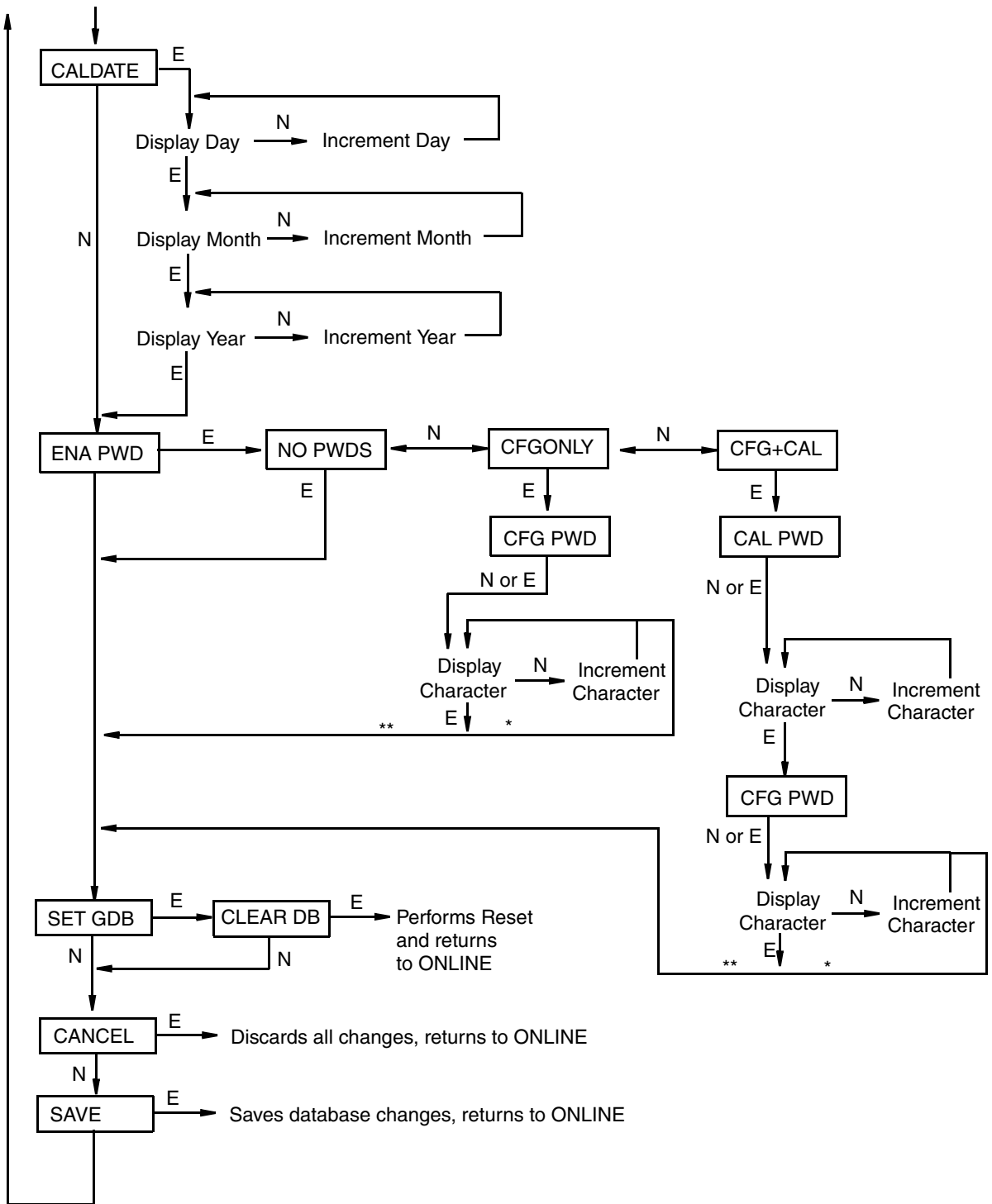

*If character is not the last position on the display line, advances to next character.
 **If character is the last position on the display line, advances to next menu item.

Figure 30. Configuration Structure Diagram (Continued)

Commentary on Configuration Structure Diagrams

In general, use the **Next** button to select your item and the **Enter** button to specify your selection.

IT MODE:

To configure the transmitter operating mode, press **Enter**. Use the **Next** button to select **4 to 20 mA** or **DIGITAL** and press **Enter**.

DevName:

The main purpose of this parameter is to identify the transmitter for its communication with an I/A Series system. In this situation, the DevName must match the letterbug used for that channel in the I/A Series system. The DevName, however, can be used for other purposes.

To edit the device name of up to six characters, go to **DevName** with the **Next** button and press **Enter**. Use the **Next** button to step through the library of characters to select the desired first character, then press **Enter**. Your selection is entered and the second character flashes. Repeat this procedure until you have created your device name. If the name has less than six characters, use blanks for the remaining spaces. When you have configured the sixth space, the display advances to the next menu item.

EX ZERO:

The External Zero feature allows the optional external zero pushbutton to be disabled for additional security. To configure this feature, go to **EX ZERO** with the **Next** button and press **Enter**. Use the **Next** button to select **EXZ DIS** or **EXZ ENA** and press **Enter**.

OUT DIR:

To configure the Output Direction, go to **OUT DIR** with the **Next** button and press **Enter**. Use the **Next** button to select **OUT FWD** (4 to 20 mA) or **OUT REV** (20 to 4 mA) and press **Enter**. This parameter is bypassed if **IT MODE** is configured **DIGITAL**.

OUTFAIL:

The Outfail feature provides high or low output with certain malfunctions. To configure the fail mode output, go to **OUTFAIL** with the **Next** button and press **Enter**. Use the **Next** button to select **FAIL LO** (3.6 mA) or **FAIL HI** (22 mA) and press **Enter**. This parameter is bypassed if **IT MODE** is configured **DIGITAL**.

OFFL MA:

The Off-line mA feature enables you to set the output to a specified value or to the last value if the transmitter goes off-line. To configure the off-line output, go to **OFFL MA** with the **Next** button and press **Enter**. Use the **Next** button to select **LAST MA** or **USER MA** and press **Enter**. If you selected **USER MA**, press **Enter** again at the display of digits. Then use the **Next** button to step through the library of digits to select the desired first digit, then press **Enter**. Your selection is entered and the second character flashes. Repeat this procedure until you have entered the last digit. Then use the **Next** button to move the decimal point to its desired location and press **Enter**. The display advances to the next menu item. This parameter is bypassed if **IT MODE** is configured **DIGITAL**.

DAMPING:

To configure additional damping, go to **DAMPING** with the **Next** button and press **Enter**. Use the **NEXT** button to select **NO DAMP**, **DAMP 1/4**, **DAMP 1/2**, **DAMP 1**, **DAMP 2**, **DAMP 4**, **DAMP 8**, **DAMP 16**, or **DAMP 32** and press **Enter**.

M1 MODE:

To configure the mode of the primary output, go to **M1 MODE** with the **Next** button and press **Enter**. Use the **Next** button to select **M1 LIN** and press **Enter**. **M1SQ<1C** (square root with cutoff below 1% of calibrated pressure range) or **M1SQ<4L** (square root with linear below 4% of calibrated pressure range) is not applicable to absolute or gauge pressure measurement.

M1 EGU:

To configure standard engineering units for your display (and transmission if in digital mode), go to **M1 EGU** with the **Next** button and press **Enter**. Use the **Next** button to select **PRESS U** or **CUST U** and press **Enter**.

If you selected **PRESS U**, you are asked to specify one of the following labels: **psig**, **psia**, **inHg**, **ftH₂O**, **inH₂O**, **atm**, **bar**, **mbar**, **MPa**, **kPa**, **Pa**, **kg/cm²**, **g/cm²**, **dy/cm²**, **cmHg**, **mmHg**, **torr**, **cmH₂O**, or **mmH₂O**. Your transmitter then automatically adjusts **M1EFAC** (engineering factor), **M1EOFF** (engineering offset), **M1 URV** (upper range value), and **M1 LRV** (lower range value).

If you want to select **CUSTM U** in order to have custom engineering units, use the following procedure:

1. **RERANGE** to the desired input pressure range in pressure units (**PRESS U**) and **Save** before selecting **CUSTM U**.
2. Select **CUSTM U** and use the following three submenus to set **M1 LBL**, **M1EFAC**, and **M1EOFF**.
3. Set **M1 URV** and **M1 LRV** in custom units.

M1 LBL:

To configure custom engineering units, press **Enter** at the prompt **M1 LBL**. The display shows the last (or default) label with the first character flashing. Use the **Next** button to step through the library of characters to select the desired first character, then press **Enter**. Your selection is entered and the second character flashes. Repeat this procedure until you have created your new label. If the label has less than six characters, use blanks for the remaining spaces. When you have configured the sixth space, the display advances to the next menu item.

— NOTE —

If you desire the engineering units in percent, enter the percent sign (%) as the first character, not the word “percent” because this could adversely affect future reranging.

M1EFAC:

This parameter is used to input the numerical relationship between the measured span in pressure units and the displayed (and transmitted) span in custom units. It must be calculated from the following formula and then entered into the database.

$$M1EFAC = \frac{\text{Maximum Span Limit}}{\text{Calibrated Span}} \times \text{Span in Custom Units}$$

where:

Maximum Span Limit is the maximum span for the transmitter (see “Span and Range Limits” on page 5)

Calibrated Span is the measurement input span (M1 URV - M1 LRV in pressure units)

— **NOTE**

Maximum Span Limit and Calibrated Span must be in the same pressure units.

Example:

For a 200 inH₂O transmitter, the input pressure range is 10 to 110 inH₂O;
Desired display and transmitted range is 25 to 75 gallons.

$$M1EFAC = \frac{200 \text{ inH}_2\text{O}}{100 \text{ inH}_2\text{O}} \times 50 \text{ gallons} = 100$$

To edit the span in your configured engineering units, press **Enter** at the prompt **M1EFAC**. Use the procedure “Entering Numerical Values” on page 32 to edit this parameter.

M1EOFF:

This parameter is used to input the numerical relationship between the measured lower range value in pressure units and the displayed (and transmitted) lower range value in custom units. It must be calculated from the following formula and then entered into the database.

$$M1EOFF = \left(\frac{\text{Measured LRV (pressure units)}}{\text{Maximum Span Limit}} \times M1EFAC \right) - \text{LRV (custom units)}$$

where:

Maximum Span Limit is the maximum span for the transmitter (see “Span and Range Limits” on page 5)

— **NOTE**

Maximum Span Limit and Measured LRV must be in the same pressure units.

Example:

For a 200 inH₂O transmitter, the input pressure range is 10 to 110 inH₂O;
Desired display and transmitted range is 25 to 75 gallons.

$$M1EOFF = \left(\frac{10 \text{ inH}_2\text{O}}{200 \text{ inH}_2\text{O}} \times 100 \right) - 25 \text{ gallons} = -20$$

To edit the offset (0% point in your configured engineering units), press **Enter** at the prompt **M1EOFF**. Use the procedure “Entering Numerical Values” on page 32 to edit this parameter.

RERANGE:

To adjust 100% and 0% range values, go to **RERANGE** with the **Next** button and press **Enter**. You can then adjust **M1 URV** and/or **M1 LRV** in the following two submenus.

M1 URV:

To edit the upper range value, press **Enter** at the prompt **M1 URV**. Use the procedure “Entering Numerical Values” on page 32 to edit this parameter.

M1 LRV:

Similar to **M1URV** immediately above.

M2 MODE:

M2 is a secondary measurement that is read by the I/A Series system and can be displayed on the optional display. You might use this feature to display M1 in your primary pressure units and M2 in other comparable units. To configure this parameter, go to **M2 MODE** with the **Next** button and press **Enter**. Use the next button to select **M2 LIN** (linear) or **M2 OFF** and press **Enter**.

M2 EGU:

Similar to **M1 EGU**.

CALDATE:

This is not a required entry but can be used for recordkeeping or plant maintenance purposes. To edit the calibration date, go to **CALDATE** with the **Next** button and press **Enter**. You then can change the day, month, and year. The display shows the last date with the day flashing. Use the **Next** button to step through the library of digits to select the desired day, then press **Enter**. Repeat this process for the month and year.

ENA PWD:

To enable or disable the password feature, go to **ENA PWD** with the **Next** button and press **Enter**. Use the **Next** button to select **NO PWDS** (password feature disabled), **CFGONLY** (password required to configure only), or **CFG+CAL** (password required to both configure and calibrate) and press **Enter**.

If you selected **CFG ONLY**, the display changes to **CFG PWD**. Press either the **Next** or **Enter** button. Use the **Next** button to step through the library of characters to select the desired first character, then press **Enter**. Your selection is entered and the second character flashes. Repeat this procedure until you have created your password. If the password has less than six characters, use blanks for the remaining spaces. When you have configured the sixth space, the display advances to the next menu item.

If you selected **CFG+CAL**, the display changes to **CAL PWD**. To create the Calibration password, press either the **Next** or **Enter** button. Use the **Next** button to step through the library of characters to select the desired first character, then press **Enter**. Your selection is entered and the second character flashes. Repeat this procedure until you have created your password. If the password has less than six characters, use blanks for the remaining

spaces. When you have configured the sixth space, the display advances to **CFG PWD**. Use the same procedure to create the configuration password.

! CAUTION
Record your new password before saving changes to the database.

SET GDB:

If your transmitter database becomes corrupted and you receive an **INITERR** message upon startup, this function enables you to rewrite all calibration and configuration values with default values.

! CAUTION
Any calibration and configuration values that you have entered will be lost. Therefore, **SET GDB** should **not** be selected if your transmitter is functioning normally.

Character Lists

Table 9. Alphanumeric Character List

Characters
(space)
%
*
+
–
/
0 through 9
<
=
>
A through Z (uppercase)
[
\
]
Δ
- (underscore)
∇
a through z (lowercase)

Table 10. Numeric Character List

Characters
– (minus sign)
. (decimal point)
0 through 9

Error Messages

Table 11. Configuration Error Messages

Parameter	Condition Tested	Error Message	User Action
Password Protection	Password	BAD PWD	Bad password entered, use another.
Write Protection	Write Protection Enabled	REJECT	Displays when user attempts an action that is write protected.
M1EFAC	M1EFAC < 0	-M1EFAC	Negative M1 EFAC is not valid. Change M1 EFAC to positive value.
	M1EFAC = 0	0M1EFAC	M1 EFAC = 0 is not valid. Change M1 EFAC to positive value.
M1 URV	M1URV > max pressure in EGU	URV>FMX	Entered pressure is greater than maximum rated pressure of transmitter. Check entry. Verify EGUs.
	M1URV < min pressure in EGU	URV<FMN	Entered pressure is less than minimum rated pressure of transmitter. Check entry. Verify EGUs.
	M1 URV = M1 LRV	LRV=URV	Cannot set span to 0. Check entry. Check M1 LRV.
	M1 turndown exceeds limit	BADTDWN	Check entry. Check M1 LRV.
M1 LRV	M1LRV > max pressure in EGU	LRV>FMX	Entered pressure is greater than maximum rated pressure of transmitter. Check entry. Verify EGUs.
	M1LRV < min pressure in EGU	LRV<FMN	Entered pressure is less than minimum rated pressure of transmitter. Check entry. Verify EGUs.
	M1 URV = M1 LRV	LRV=URV	Cannot set span to 0. Check entry. Check M1 URV.
	M1 turndown exceeds limit	BADTDWN	Check entry. Check M1 URV.
M2EFAC	M2EFAC < 0	-M2EFAC	Negative M2 EFAC is not valid. Change M2 EFAC to positive value.
	M2EFAC = 0	0M2EFAC	M2 EFAC = 0 is not valid. Change M2 EFAC to positive value.

6. Maintenance

—  **DANGER** —

For nonintrinsically safe installations, to prevent a potential explosion in a Division 1 hazardous area, de-energize transmitters before you remove threaded housing covers. Failure to comply with this warning could result in an explosion resulting in severe injury or death.

Fault Analysis

For error messages displayed with a PC20 or PC50, refer to MI 020-495 or MI 020-504 respectively.

In rare cases, the transmitter database can become corrupted and the transmitter does not go on-line when powered. This can potentially occur if power to the transmitter is interrupted during a **Save** operation. The optional display continually shows an alternating display of **INITERR** and **RESET**.

To restore the transmitter from this condition, use the **SET GDB** function. Because the **SET GDB** function sets a default database and overwrites all calibration and configuration data, the transmitter needs to be reconfigured and recalibrated.

Parts Replacement

Parts replacement is generally limited to the electronics module assembly, housing assembly, sensor assembly, terminal block assembly, cover O-rings, and optional display. For part numbers relating to the transmitter and its options, see the following parts lists:

IAP10 Absolute and IGP10 Gauge Pressure Transmitters: PL 009-006

IGP10 High Gauge Pressure: PL 009-010

Replacing the Terminal Block Assembly

1. Turn off transmitter power source.
2. Remove the Field Terminals and the Electronics compartment covers by rotating them counterclockwise. Screw in cover lock if applicable.
3. Remove the digital display (if applicable) as follows: grasp the two tabs on the display and rotate it about 10° in a counterclockwise direction.
4. Remove the electronics module from the housing by loosening the two captive screws that secure it to the housing. Then pull the module out of the housing far enough to gain access to the cable connectors on the rear of the module.
5. Remove the four socket head screws securing the terminal block.
6. Disconnect the terminal block cable connector from the electronics module.

7. Remove the terminal block and the gasket under it.
8. Connect the new terminal block cable connector to the electronics module.
9. Install the new terminal block and new gasket and reinstall the four screws to 0.67 N·m (6 in·lb) in several even increments.
10. Reinstall the electronics module (and digital display if applicable).
11. Reinstall the covers onto the housing by rotating them clockwise to seat the O-ring into the housing and then continue to hand tighten until the each cover contacts the housing metal-to-metal. If cover locks are present, lock the cover per the procedure described in “Cover Locks” on page 23.
12. Turn on transmitter power source.

Replacing the Electronics Module Assembly

To replace the electronics module assembly, refer to Figure 31 and proceed as follows:

1. Turn off transmitter power source.
2. Remove the electronics compartment cover by rotating it counterclockwise. Screw in cover lock if applicable.
3. Remove the digital display (if applicable) as follows: grasp the two tabs on the display and rotate it about 10° in a counterclockwise direction. Pull out the display and disconnect its cable.
4. Remove the electronics module from the housing by loosening the two captive screws that secure it to the housing. Then pull the module out of the housing far enough to gain access to the cable connectors on the rear of the module.

 **CAUTION**

The electronics module is “one assembly” at this point and is electrically and mechanically connected to topworks with a flexible ribbon signal cable, a 2-wire power cable, and in some cases, a cable for an external zero pushbutton. Do **not** exceed the slack available in these cables when removing the assembled module.

5. Unplug all cable connectors from the rear of the electronics module and place the module on a clean surface.
6. Predetermine connector orientation, then insert the cable connectors into the replacement module. Replace the module in the housing using care not to pinch the cables between the module and the housing. Tighten the two screws that secure the module to the housing.
7. Connect the cable from the digital display to the electronics module. Ensure that the O-ring is fully seated in the display housing. Then, holding the digital display by the tabs at the sides of the display, insert it into the housing. Secure the display to the housing by aligning the tabs on the sides of the assembly and rotating it about 10° in a clockwise direction.
8. Reinstall the cover onto the housing by rotating it clockwise to seat the O-ring into the housing and then continue to hand tighten until the cover contacts the housing

metal-to-metal. If cover locks are present, lock the cover per the procedure described in “Cover Locks” on page 23.

9. Turn on transmitter power source.

The module replacement procedure is now complete.

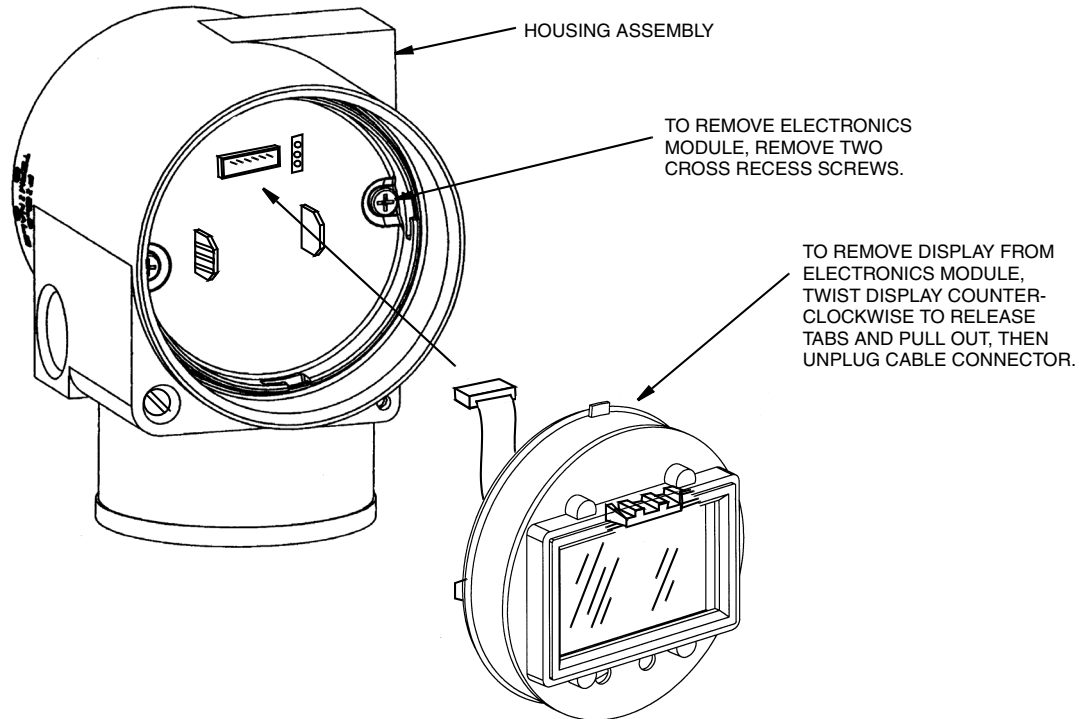

Figure 31. Replacing the Electronics Module Assembly and Display

Removing and Reinstalling a Housing Assembly

To remove and reinstall a housing assembly, refer to Figure 31 and proceed as follows:

1. Remove the electronics module per Steps 1 through 5 in the previous procedure.
2. If your housing has an anti-rotation screw, remove the red lacquer from the screw recess. Turn the screw three full turns counterclockwise.
3. If your housing has a retention clip, remove the red lacquer from the screw recess. Remove the screw completely, and slide the clip off the housing. Save the clip and screw for future use,
4. Remove the housing by rotating it counterclockwise (when viewed from the top). Use caution to avoid damaging the sensor cable.
5. Inspect the sensor O-ring for damage. If the O-ring is damaged, replace it with the appropriate O-ring. (See parts list for your transmitter). Lubricate the O-ring with silicone lubricant (Foxboro Part Number 0048130 or equivalent). Verify that the O-ring is situated in the groove of the neck.

! WARNING

Failure to reuse or install the proper O-ring for a CSA labeled product violates ANSI / ISA 12.27.01.

6. Feed the sensor cable through the housing neck into the electronics compartment.
7. Screw the housing onto the sensor neck until it bottoms. Do not over tighten. Be careful not to damage the sensor cable or dislodge the neck O-ring.
8. If your housing has an anti-rotation screw, engage the screw until it touches the sensor neck and back it off 1/8th turn. It is important that the screw is not touching the sensor. Fill the screw recess with red lacquer (Foxboro Part Number X0180GS or equivalent). the housing may then be rotated up to one full turn counterclockwise for optimum access.
9. If your housing has a retention clip, insert the clip over the boss in the housing neck so that the hole in the clip is aligned with the hole in the boss. Install the screw but do not tighten. Rotate the housing up to one full turn counterclockwise for optimum access. Tighten the retention clip screw and fill the screw recess with red lacquer (Foxboro Part Number X0180GS or equivalent). The housing can still be rotated for optimum access.
10. Reinstall the electronics module per Steps 6 through 9 in the previous procedure.

Adding the Optional Display

To add the optional display, refer to Figure 31 and proceed as follows:

1. Turn off transmitter power source.
2. Remove the electronics compartment cover by rotating it counterclockwise. Screw in cover lock if applicable.
3. Plug the display into the receptacle at the top of the electronics assembly.
4. Ensure that the O-ring is seated in its groove in the display housing. Then insert the display into the electronics compartment by grasping the two tabs on the display and rotating it about 10° in a clockwise direction.
5. Install the new cover (with a window) onto the housing by rotating it clockwise to seat the O-ring into the housing and then continue to hand tighten until the cover contacts the housing metal-to-metal. If cover locks are present, lock the cover per the procedure described in “Cover Locks” on page 23.
6. Turn on transmitter power source.

Replacing the Sensor Assembly

To replace the sensor assembly, refer to Figure 31 and proceed as follows:

1. Remove the electronics module as described above.
2. Remove the housing as described above. Sensor is left.
3. Install housing on new sensor.
4. Reinstall electronics module.

Index

B

Bench Calibration Setup 39

C

Calibration 35

Notes 35

Setup 37

Using a PC20 39

Using a PC50 39

Using the Local Display 39

Configuration 45

Using a PC20 46

Using a PC50 46

Using the Local Display 46

Cover Locks 23

D

Display, Positioning the 22

E

Error Messages

Calibration 44

Configuration 57

Operation 34

F

Fault Analysis 59

H

Housing, Positioning the 21

I

Identification 2

Installation 15

M

Maintenance 59

Mounting 15

P

Parts Replacement 59
 Piping, Typical Transmitter 20

R

Reference Documents 1

S

Specifications
 Product Safety 11
 Standard 5

W

Write Protect Jumper 22

Z

Zero Adjustment 43

ISSUE DATES

DEC 2001
 OCT 2003
 APR 2004
 FEB 2005
 FEB 2006
 OCT 2007
 MAR 2009
 MAY 2010

Vertical lines to the right of text or illustrations indicate areas changed at last issue date.

	<p>Invensys Operations Management 5601 Granite Parkway Suite 1000 Plano, TX 75024 United States of America http://www.iom.invensys.com</p> <p>Global Customer Support Inside U.S.: 1-866-746-6477 Outside U.S.:1-508-549-2424 or contact your local Invensys representative. Email: support@invensys.com Website: http://support.ips.invensys.com</p>	<p>Invensys, Foxboro, and I/A Series are trademarks of Invensys plc, its subsidiaries, and affiliates. All other brand names may be trademarks of their respective owners.</p> <p>Copyright 2001-2010 Invensys Systems, Inc. All rights reserved</p>
---	--	--