

**I/A Series® Intelligent
Electronic Multivariable Transmitters**

**IMV25-T and IMV30-T
with HART or 4 to 20 mA Output Signals**

**Installation, Calibration, Configuration, and Maintenance
Style A**

Contents

Figures.....	v
Tables.....	vi
1. Introduction	1
General Description	1
Reference Documents	1
Transmitter Identification	2
Standard Specifications	3
Product Safety Specifications	9
ATEX and IECEx Warnings	11
ATEX Compliance Documents	11
IECEx Compliance Documents	11
2. Installation	13
Transmitter Mounting	13
Process-Mounted Transmitter	14
Manifold Mounted Transmitter	14
Pipe- or Surface-Mounted Transmitter	15
Standard Mounting Bracket	15
Universal Mounting Bracket	17
Venting and Draining	20
Traditional Structure	20
LP1 Low Profile Structure	20
LP2 Low Profile Structure	21
Installation of Flow Measurement Piping	21
Filling System with Seal Liquid	24
Positioning Housing	25
Positioning Optional Display	25
Setting the Write Protect Jumper	26
Cover Locks	26
Transmitter Wiring	26
Accessing Transmitter Field Terminals	26
Supply Voltage	27
Electrical Ground Connections	28
Wiring the Transmitter	28
Wiring the Transmitter To A Loop	28
Multidrop Communication	30
Connecting the Transmitter To an I/A Series System	31
Connecting the RTD	33

Putting Transmitter into Operation	33
Taking Transmitter out of Operation	34
3. Calibration and Configuration	35
Calibration Setup	35
Configurable Parameters	37
Calibration and Configuration Using a PC-Based Configurator	40
Calibration and Configuration Using a HART Communicator	40
Online Menu	40
Explanation of Parameters	42
Calibration and Configuration Using the Optional Local Display	45
Entering Numerical Values	47
Calibration	48
Configuration	53
Viewing the Database	63
Testing the Display	63
Error Messages	63
4. Maintenance.....	71
Fault Analysis	71
Parts Replacement	71
Replacing the Electronics Module	71
Removing and Reinstalling a Housing Assembly	74
Replacing the Sensor Assembly	74
Replacing the Terminal Block Assembly	76
Adding the Optional Display	76
Rotating Process Covers for Venting	76
Index	79

Figures

1	Transmitter Identification	2
2	Minimum Allowable Absolute Pressure vs. Sensor Temperature with Fluorinert Fill Fluid	6
3	Typical Mounting of an IMV25 Transmitter Supported by Process Piping	14
4	Typical Mounting of an IMV25 Transmitter Supported by a Bypass Manifold	14
5	Typical Mounting of IMV25 Transmitter on Coplanar%o Manifold	15
6	Pipe or Surface Mounted Transmitter Using a Standard Bracket	16
7	Examples of Mounting With a Standard Bracket	16
8	Details of a Universal Bracket	17
9	Mounting a Transmitter with Traditional Structure Using a Universal Bracket	18
10	Vertical Pipe Mounting a Transmitter with LP2 Structure Using a Universal Bracket ..	18
11	Horizontal Mounting a Transmitter with LP2 Structure Using a Universal Bracket	19
12	Vertical Mounting - Cavity Draining	20
13	Vertical Mounting - Cavity Venting	20
14	Horizontal Mounting - Cavity Venting	20
15	Vertical Mounting - Cavity Venting	21
16	Horizontal Mounting - Cavity Venting and Draining	21
17	Cavity Venting and Draining	21
18	Example of Horizontal Process Line Installation	23
19	Example of Vertical Process Line Installation	24
20	Housing Screw or Clip Location	25
21	Accessing Field Terminals	27
22	Identification of Field Terminals	27
23	Supply Voltage and Loop Load	29
24	Loop Wiring Transmitters	30
25	Typical Multidrop Network	31
26	Typical Transmitter Wiring to an I/A Series System	32
27	RTD Wiring	33
28	Setup for Differential Pressure Calibration	36
29	Setup for Absolute Pressure Calibration	37
30	4 to 20 mA Output Calibration Setup	37
31	HART Communicator Online Menu (1 of 2)	40
32	HART Communicator Online Menu (2 of 2)	41
33	Local Display Module	46
34	Top Level Structure Diagram	47
35	Calibration Structure Diagram	50
36	Configuration Structure Diagram	54
37	Replacing the Electronics Module Assembly and Display	73
38	Replacing the Sensor Assembly	75
39	Sensor Cavity Venting and Draining	77

Tables

1	Reference Documents	1
2	Minimum Loop Load and Supply Voltage Requirements	7
3	Electrical Safety Specifications	10
4	Minimum Loop Load and Supply Voltage Requirements	28
5	Configurable Parameters	38
6	Calibration Menu	48
7	Calibration Error Messages	63
8	Configuration Error Messages	66
9	Operation Error Messages	69

1. Introduction

General Description

The IMV25-T Electronic Multivariable Transmitter measures absolute and differential pressure, sensor and electronics temperature, and process temperature (from an RTD). It also provides transmission of all the measured values.

The IMV30-T Electronic Multivariable Transmitter measures absolute and differential pressure, sensor and electronics temperature, and process temperature (from an RTD). It also calculates process density and flow rate and provides transmission of all the measured and calculated values.

The signals are transmitted to remote receivers over the same two wires that supply power to the transmitter electronics. These wires also carry two-way data signals between the transmitter and remote communication devices.

Both transmitters allow direct analog connection to common receivers while still providing intelligent transmitter digital communications using a HART Communicator.

Reference Documents

This document (MI 020-382) contains instructions for transmitter installation, local configuration, calibration, and maintenance details. For further information relating to the use of this transmitter, refer to Table 1.

Table 1. Reference Documents

Document	Description
DP 020-432	Dimensional Print – IMV25 and IMV30 Multivariable Transmitter
MI 020-427	Instruction – Intrinsic Safety Connection Diagrams and Nonincendive Circuits
MI 020-496	Instruction – PCMV Intelligent Field Device Configurator
PL 009-018	Parts List – IMV30 Multivariable Transmitter
PL 009-019	Parts List – IMV25 Multivariable Transmitter
TI 37-75b	Technical Information – Transmitter Material Selection Guide

Transmitter Identification

See Figure 1 for transmitter data plate contents. For a complete explanation of the Model Number code, see PL 009-018. The firmware version is identified under **FMW REV** when **VIEW DB** (View Database) is selected in the top level structure (see Figure 34 on page 47).

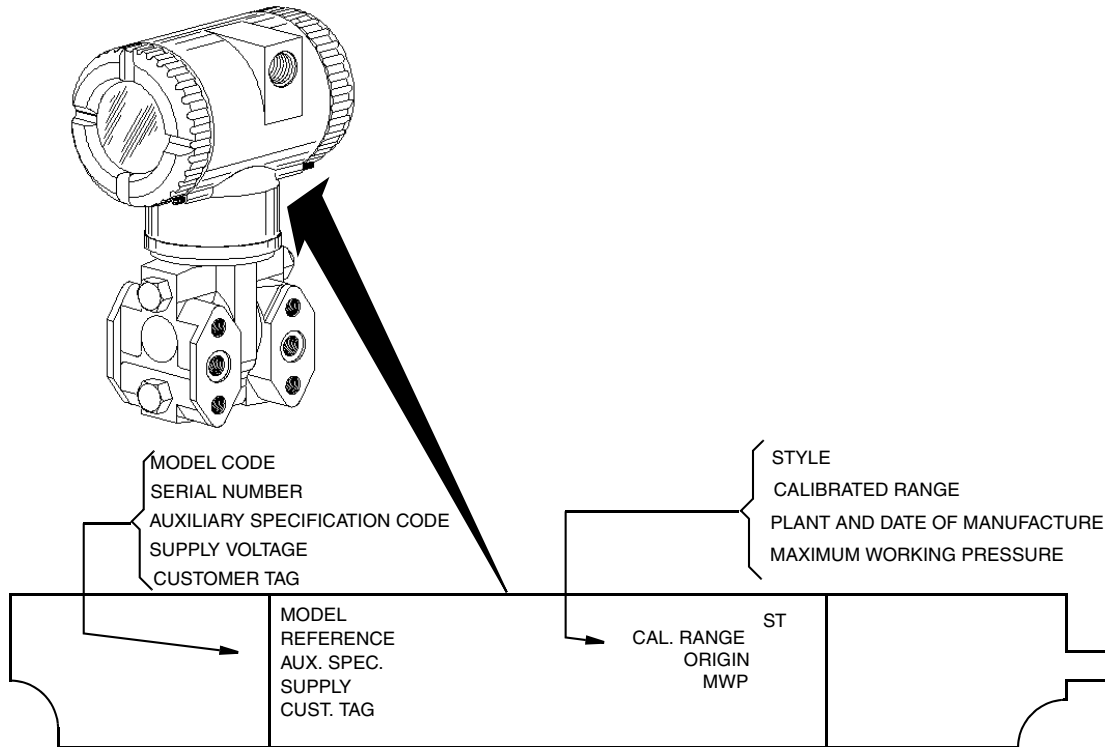

Figure 1. Transmitter Identification

Standard Specifications

Span and Range Limits for Differential Pressure Measurement

Span Limit Code	Span Limits ΔP	Range Limits $\Delta P^{(a)}$
L	0.12 and 2.5 kPa (0.5 and 10 inH ₂ O)	-2.5 and +2.5 kPa (-10 and +10 inH ₂ O)
A	0.75 and 7.5 kPa (3 and 30 inH ₂ O)	-7.5 and +7.5 kPa (-30 and +30 inH ₂ O)
B	0.5 and 50 kPa (2 and 200 inH ₂ O)	-50 and +50 kPa (-200 and +200 inH ₂ O)
C	2.5 and 210 kPa (10 and 840 inH ₂ O)	-210 and +210 kPa (-840 and +840 inH ₂ O)

(a) Negative values of differential pressure indicate a higher pressure on the **low side** of the sensor. Positive values indicate a higher pressure on the **high side** of the sensor.

Span and Range Limits for Absolute Pressure Measurement

Span Limit Code	Span Limits ΔP	Range Limits ΔP
D	0.02 and 2.1 MPa (3 and 300 psia)	0 and 2.1 MPa (0 and 300 psia)
G	0.07 and 3.5 MPa (10 and 500 psia)	0 and 3.5 MPa (0 and 500 psia)
E	0.21 and 10 MPa (30 and 1500 psia)	0 and 10 MPa (0 and 1500 psia)
H	0.42 and 20.7 MPa (60 and 3000 psia)	0 and 20.7 MPa (0 and 3000 psia)
F	3.45 and 36.5 MPa (500 and 5300 psia)	0 and 36.5 MPa (0 and 5300 psia)

Maximum Static, Working, and Overrange Pressure

Span Code ^(a)	Sensor URL		Maximum Static		Max Working (MWP)		Maximum Overrange	
	Differential Pressure	Absolute Pressure	MPa	psi	MPa	psi	MPa	psi
A G	30 inH ₂ O	500 psia	3.5	500	3.5	500	5.2	750
B D	200 inH ₂ O	300 psia	2.1	300	2.1	300	3.1	450
B E	200 inH ₂ O	1500 psia	10	1500	10	1500	15.0	2250
B H	200 inH ₂ O	3000 psi	20.7	3000	20.7	3000	31.0	4500
B F	200 inH ₂ O	5300 psia	36.5	5300	36.5	5300	51.2	7420
C D	840 inH ₂ O	300 psia	2.1	300	2.1	300	3.1	450
C E	840 inH ₂ O	1500 psia	10	1500	10	1500	15	2250
C H	840 inH ₂ O	3000 psia	20.7	3000	20.7	3000	31.0	4500

Span Code ^(a)	Sensor URL		Maximum Static		Max Working (MWP)		Maximum Overrange	
	Differential Pressure	Absolute Pressure	MPa	psi	MPa	psi	MPa	psi
C F	840 inH ₂ O	5300 psia	36.5	5300	36.5	5300	51.2	7420
L G	10 inH ₂ O	500 psia	3.5	500	3.5	500	5.2	750

(a) Available combinations of DP and AP sensors.

— NOTE —

Static pressure zero shift for all calibrated spans can be minimized by readjusting the zero output at nominal operating static pressure.

— CAUTION —

Exceeding the maximum overrange pressure can cause damage to the transmitter degrading its performance.

Process Temperature Measurement

Measurement Element: 2-, 3-, or 4-wire, 100 ohm platinum RTD

DIN 43760; IEC 751, mean temperature coefficient (alpha) of 0.00385 ohms/ohm/°C

Range Limits: -200 and +850°C (-328 and +1562°F)

Elevated Zero and Suppressed Zero

For applications requiring an elevated or suppressed zero, the maximum span and the upper and lower range limits of the transmitter can not be exceeded.

Output Signal

The output is remotely configurable from a PC-Based Configurator or the HART Communicator. It is also locally configurable with the pushbuttons on the optional display.

Zero and Span Adjustments

The zero and span is remotely adjustable from the PC-Based Configurator or the HART Communicator. They are also adjustable at the transmitter using the optional display.

Field Wiring Reversal

Accidental reversal of field wiring does not damage the transmitter, provided the current is limited to 1 A or less by active current limiting or loop resistance. Sustained currents of 1 A does not damage the electronics module or sensor but could damage the terminal block assembly and external instruments in the loop.

Mounting Position

The transmitter can be mounted in any orientation. Position effect zero shift for all calibrated spans can be eliminated by readjusting zero output after installation.

Adjustable Damping

The transmitter response time is normally 1.0 second or the electronically adjustable setting of 0.00 (none), 0.25, 0.50, 1, 2, 4, 8, 16, or 32 seconds, whichever is greater, for a 90% recovery from an 80% input step as defined in ANSI/ISA S51.1.

Operative Limits

Influence	Normal Operating Conditions	Operative Limits
Sensor Body Temperature		
Silicone Fill Fluid	-29 and +82°C (-20 and +180°F)	-46 and +121°C (-50 and +250°F)
Fluorinert Fill Fluid	-29 and +82°C (-20 and +180°F)	-29 and +121°C (-20 and +250°F)
Electronics Temperature	-29 and +82°C (-20 and +180°F)	-40 and +85°C (-40 and +185°F)
With LCD Display	-20 and +82°C (-4 and +180°F)*	-29 and +85°C (-20 and +185°F)*
Relative Humidity	0 and 100%	0 and 100%
Supply Voltage	11.5 and 42 V dc	11.5 and 42 V dc
Output Load**	0 and 1450 ohms**	0 and 1450 ohms**
Mounting Position	Upright or horizontal	No Limit

*Display updates is slowed and readability decreased at temperatures below -20°C (-4°F).

**250 Ω minimum load is required for communication with a HART Communicator. Refer to Figure 23.

Sensor Fill Fluid

Silicone Oil (DC 200) or Fluorinert (FC-43)

Minimum Allowable Absolute Pressure vs. Sensor Temperature

With Silicone Fill Fluid: At full vacuum: Up to 121°C (250°F)
 With Fluorinert Fill Fluid: Refer to Figure 2.

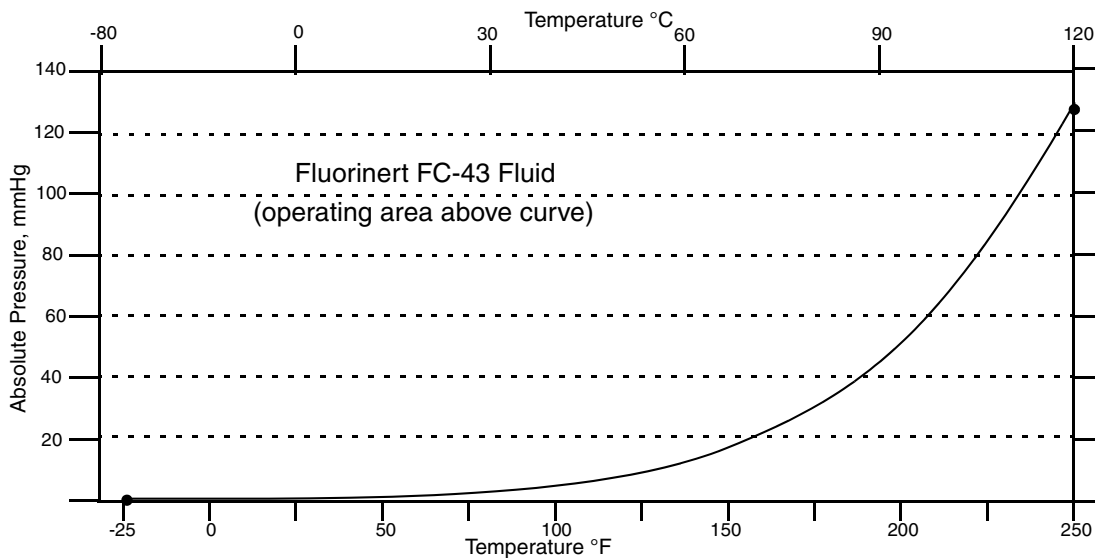

Figure 2. Minimum Allowable Absolute Pressure vs. Sensor Temperature with Fluorinert Fill Fluid

Electrical Connections

Field wires enter through 1/2 NPT, PG 13.5 or M20 threaded entrances on either side of the electronics housing. Leads terminate under screw terminals and washers on the

terminal block in the field terminal compartment. Unused conduit connection must be plugged with metal plug provided to maintain RFI/EMI, environmental, and explosionproof ratings.

Process Connections

The transmitters are connected to the process via a 1/4 NPT thread or any one of a number of optional process connectors.

Supply Voltage

Power supply must be capable of providing 22 mA when the transmitter is configured for 4 to 20 mA output. Ripple of up to 2 V pp (50/60/100/120 Hz) is tolerable, but instantaneous voltage must remain within specified range.

The supply voltage and loop load must be within specified limits. This is explained in detail in “Wiring the Transmitter To A Loop” on page 28. A summary of the minimum requirements are listed in Table 2

Table 2. Minimum Loop Load and Supply Voltage Requirements

	HART Communication	No HART Communication
Minimum Resistance	250 Ω	0
Minimum Supply Voltage	16 V	11.5 V

Electrical Ground Connections

The transmitter is equipped with an internal ground connection within the field wiring compartment and an external ground connection at the base of the electronics housing. To minimize galvanic corrosion, place the wire lead or terminal between the captive washer and loose washer on the external ground screw. If shielded cable is used, earth (ground) the shield at the field enclosure **only**. Do **not** ground the shield at the transmitter.

Test Points

The two lower banana plug receptacles (designated **CAL**) can be used to check transmitter output when configured for 4 to 20 mA. Measurements should be 100-500 mV dc for 0-100% transmitter output. Refer to Figure 22.

Approximate Mass

Without Process Connectors	3.5 kg (7.8 lb)
With Process Connectors	4.2 kg (9.2 lb)
With Optional 316 ss Housing	Add 1.1 kg (2.4 lb)

Process Wetted Materials

Sensor: 316L ss or Hastelloy C

Covers and Process Connections: 316 ss or Hastelloy C

Remote Communications

The transmitter communicates bidirectionally over the 2-wire field wiring to a PC-based Configurator, a HART Communicator, and/or to the I/A Series system.

The information that can be continuously displayed is:

- ◆ Differential Pressure
- ◆ Pressure
- ◆ Process Temperature (from external RTD)
- ◆ Sensor Temperature
- ◆ Electronics Temperature
- ◆ Flow Rate (IMV30 only)
- ◆ Flowing Density (IMV30 only).

— NOTE

The I/A Series system is limited to displaying a maximum of three of these measurements.

The information that can be remotely displayed and reconfigured, using the PC-based Configurator or HART Communicator includes:

- ◆ Output in mA, Percent, or Engineering Units (EGU)
- ◆ Zero and Span, including reranging
- ◆ Zero Elevation or Suppression
- ◆ Linear or Square Root Output
- ◆ Pressure or Plant EGU
- ◆ Temperature Sensor Failure Strategy
- ◆ Electronic Damping
- ◆ Poll Address (Multidrop mode)
- ◆ Fail-safe Direction
- ◆ Tag, Description, and Message
- ◆ Date of Last Calibration.

Communications Format

Communication is based upon the FSK (Frequency Shift Keying) technique. The frequencies are superimposed on the transmitter power/signal leads.

Output

The transmitter sends its measurement to the loop as a continuous 4 to 20 mA dc signal. The 4 to 20 mA signal can be assigned to any one of the measurements (differential

pressure, absolute pressure, process temperature, electronics temperature, sensor temperature, flow, or density). It communicates digitally with a HART Communicator and PC-Based Configurator at distances up to 3050 m or 10000 ft (1525 m or 5000 ft with multidrop communication). Communication between the remote configurator and the transmitter does not disturb the 4 to 20 mA output signal.

Other specifications are:

Data Transmission Rate	1200 Baud
4 to 20 mA Update Rate	30 times/second minimum (4 times/second with multidrop communications)
Output when Underrange	3.8 mA
Output when Overage	20.5 mA
Output for Fail Low	3.6 mA
Output for Fail High	21 mA
Output when Off-line	Last value or configurable from 4 to 20 mA

Product Safety Specifications

— **DANGER**

To prevent possible explosions and to maintain flameproof, explosionproof, and dust-ignitionproof protection, observe applicable wiring practices. Plug unused conduit opening with the provided metal pipe plug. Both plug and conduit must engage a minimum of five full threads for 1/2 NPT connections; seven full threads for M20 and PG 13.5 connections.

— **WARNING**

To maintain IEC IP66 and NEMA Type 4X protection, the unused conduit opening must be plugged with the metal plug provided. Use a suitable thread sealant on both conduit connections. In addition, the threaded housing covers must be installed. Turn covers to seat the O-ring into the housing and then continue to hand tighten until the cover contacts the housing metal-to-metal.

— **NOTE**

1. These transmitters have been designed to meet the electrical safety description listed in Table 3. For detailed information or status of testing laboratory approvals/certifications, contact Invensys.
 2. Wiring restrictions required to maintain electrical certification of the transmitter are provided in the “Transmitter Wiring” section of this document on page 26 and in MI 020-427.
-

Table 3. Electrical Safety Specifications

Testing Laboratory, Types of Protection, and Area Classification	Application Conditions	Electrical Safety Design Code
ATEX flameproof; II 2 GD EEx d IIC, Zone 1.	KEMA 00ATEX2019X Temperature Class T6 T85°C Ta = -40 to +80°C	D
ATEX intrinsically safe; II 1 GD, EEx ia IIC, Zone 0 or II 1/2 GD EEx ib IIC, Zone 0 and 1.	KEMA 00ATEX1009X Temperature Class T4 at 80°C, T5 at 40°C, and T6 at 40°C maximum ambient.	E
ATEX protection n; II 3 GD, EEx nL IIC, Zone 2.	KEMA 00ATEX1060X Temperature Class T4 at 80°C, T5 at 70°C, and T6 at 40°C maximum ambient.	N
ATEX multiple certifications, ia & ib, d, and n. Refer to Codes D, E and N for details.	Applies to Codes D, E, and N. ^(a)	M
CSA intrinsically safe for Class I, Division 1, Groups A, B, C, and D; Class II, Division 1, Groups E, F, and G; Class III, Division 1. Also, Zone certified intrinsically safe Ex ia IIC and energy limited Ex nA II.	Connect per MI 020-427. Temperature Class T4A at 40°C (104°F) and T3C at 85°C (185°F) maximum ambient. Temperature Class T4 at 40°C (104°F), and T3 at 85°C (185°F) max. ambient.	C
CSA explosionproof for Class I, Division 1, Groups B, C, and D; and dust-ignitionproof apparatus for Class II, Division 1, Groups E, F, and G; and Class III, Division 1.	Maximum Ambient Temperature 85°C (185°F).	
CSA for Class I, Division 2, Groups A, B, C, and D; Class II, Division 2, Groups F and G; and Class III, Division 2.	Temperature Class T4A at 40°C (104°F) and T3C at 85°C (185°F) maximum ambient.	
CSA field device zone certified flameproof Ex d IIC. Also, all certifications of Code C above.	Maximum Ambient Temperature 85°C (185°F).	B

Table 3. Electrical Safety Specifications

Testing Laboratory, Types of Protection, and Area Classification	Application Conditions	Electrical Safety Design Code
FM intrinsically safe for Class I, Division 1, Groups A, B, C, and D; Class II, Division 1, Groups E, F, and G; and Class III, Division 1. Also, Zone certified intrinsically safe AEx ia IIC.	Connect per MI 020-427. Temperature Class T4A at 85°C (185°F) maximum ambient. Temperature Class T4 at 85°C (185°F) maximum ambient.	F
FM explosionproof for Class I, Division 1, Groups B, C, and D; and dust-ignitionproof apparatus for Class II, Division 1, Groups E, F, and G; and Class III, Division 1.	Temperature Class T6 at 80°C (176°F) and T5 at 85°C (185°F) maximum ambient.	
FM nonincendive apparatus for Class I, Division 2, Groups A, B, C, and D; Class II, Division 2, Groups F and G; and Class III, Division 2.	Temperature Class T4A at 85°C (185°F) maximum ambient.	
FM field device zone certified flameproof AEx d IIC. Also, all certifications of Code F above.	Temperature Class T6 at 80°C (176°F) and T5 at 85°C (185°F) maximum ambient.	G
IECEx flameproof: Ex d IIC	IECEx FMG 06.0007X, Ex d IIC T6 Ta=80°C, T5 Ta=85°C Ambient Temperature -20 to +85°C	V

(a) User must permanently mark (check off in rectangular block on data plate) one type of protection only (ia and ib or n). This mark cannot be changed once it is applied.

ATEX and IECEx Warnings

Do not open while circuits are alive.

ATEX Compliance Documents

EN 50014: 1997

EN 50018: 1994

EN 50020: 1994

EN 50284: 1999

EN 50021: 1999

IECEx Compliance Documents

IEC 60079-0 (Edition 4.0): 2004

IEC 60079-1 (Edition 5): 2003

2. Installation

The following material provides information and procedures for installing the transmitter. For dimensional information, refer to DP 020-432.

— **! CAUTION** —

To avoid damage to the transmitter sensor, do not use any impact devices, such as an impact wrench or stamping device, on the transmitter.

— **NOTE** —

Use a suitable thread sealant on all connections.

Transmitter Mounting

The transmitter can be supported by the process piping (Figure 3), on a bypass manifold (Figures 4 through 5), or mounted to a vertical or horizontal pipe or surface using an optional mounting bracket (Figures 6 through 11).

— **NOTE** —

1. If the transmitter is not installed in the vertical position, readjust zero output to eliminate the position zero effect.
2. The transmitter should be mounted so that any moisture condensing or draining into the field wiring compartment can exit through one of the two threaded conduit connections.

Process-Mounted Transmitter

Figure 3 shows the transmitter mounted to and supported by the process piping.

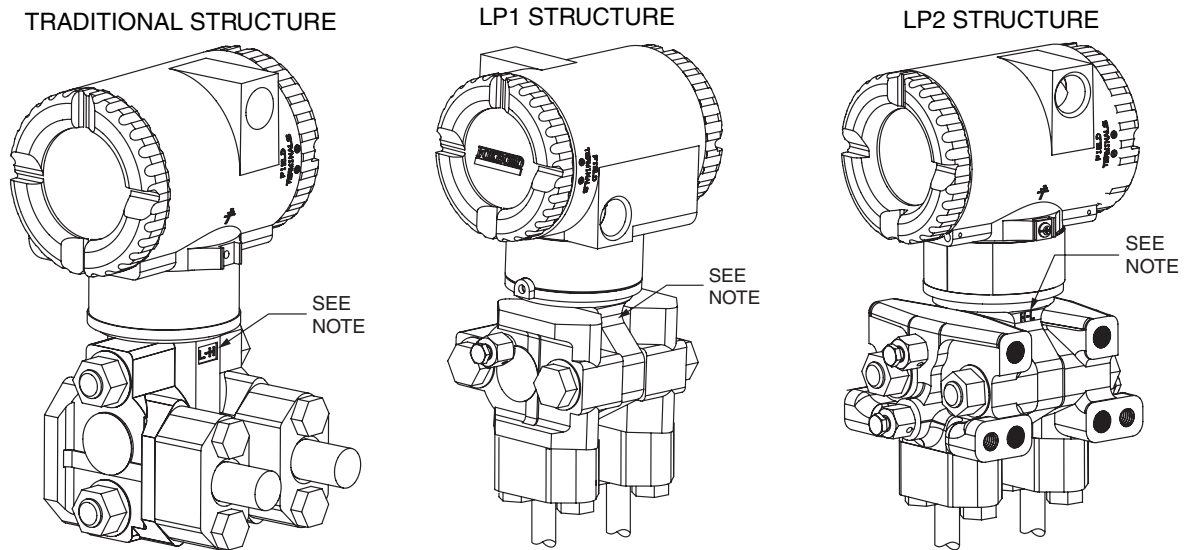

NOTE: MARK INDICATING LOW AND HIGH PRESSURE SIDE OF TRANSMITTER

Figure 3. Typical Mounting of an IMV25 Transmitter Supported by Process Piping

Manifold Mounted Transmitter

Figures 4 and 5 shows the transmitter mounted to and supported by a bypass manifold.

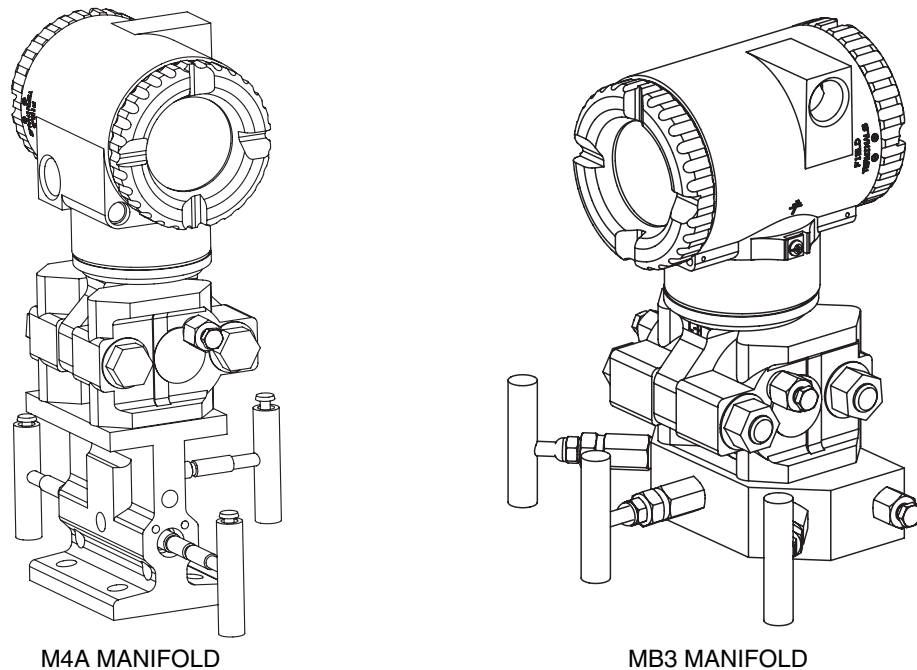

Figure 4. Typical Mounting of an IMV25 Transmitter Supported by a Bypass Manifold

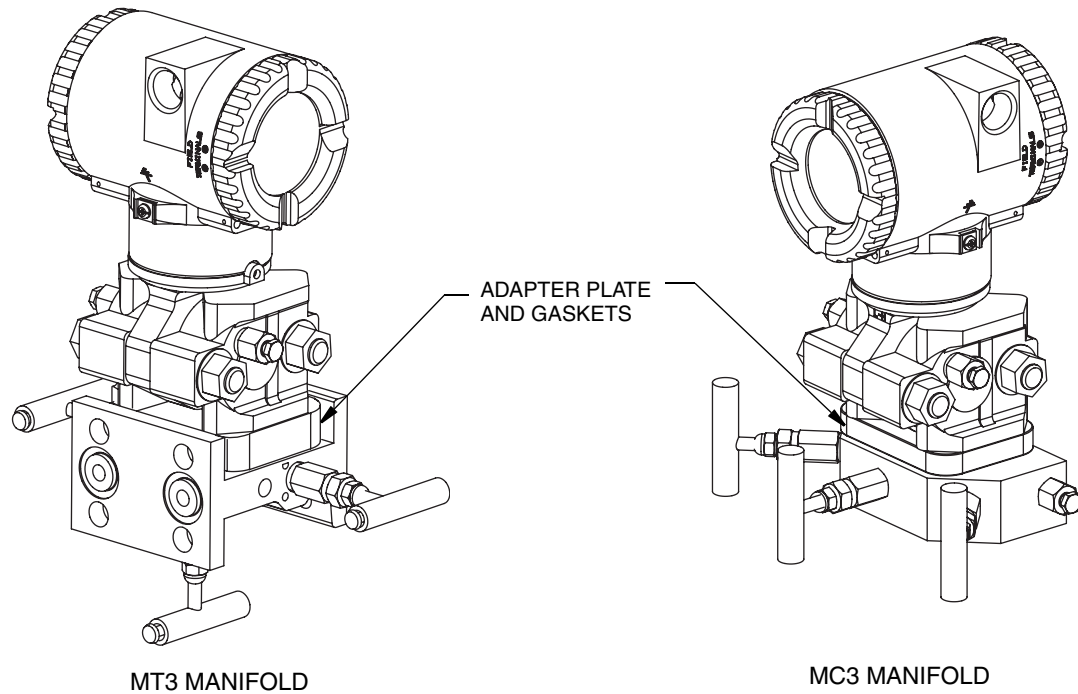

Figure 5. Typical Mounting of IMV25 Transmitter on Coplanar™ Manifold

Pipe- or Surface-Mounted Transmitter

To mount the transmitter to a pipe or surface, use the Standard Mounting Bracket Set (Model Code Option -M1 or -M2) or Universal Bracket Mounting Set (Model Code Option -M3).

Standard Mounting Bracket

The transmitter (with either traditional or LP2 low-profile structures) can be mounted to a vertical or horizontal, DN 50 or 2-in pipe using a standard bracket. See Figure 6 for details and Figure 7 for examples of different situations. Secure the mounting bracket to the transmitter using the four screws provided. Mount the bracket to the pipe. To mount to a horizontal pipe, turn the U-bolt 90° from the position shown in Figure 6. The mounting bracket can also be used for wall mounting by securing the bracket to a wall using the U-bolt mounting holes.

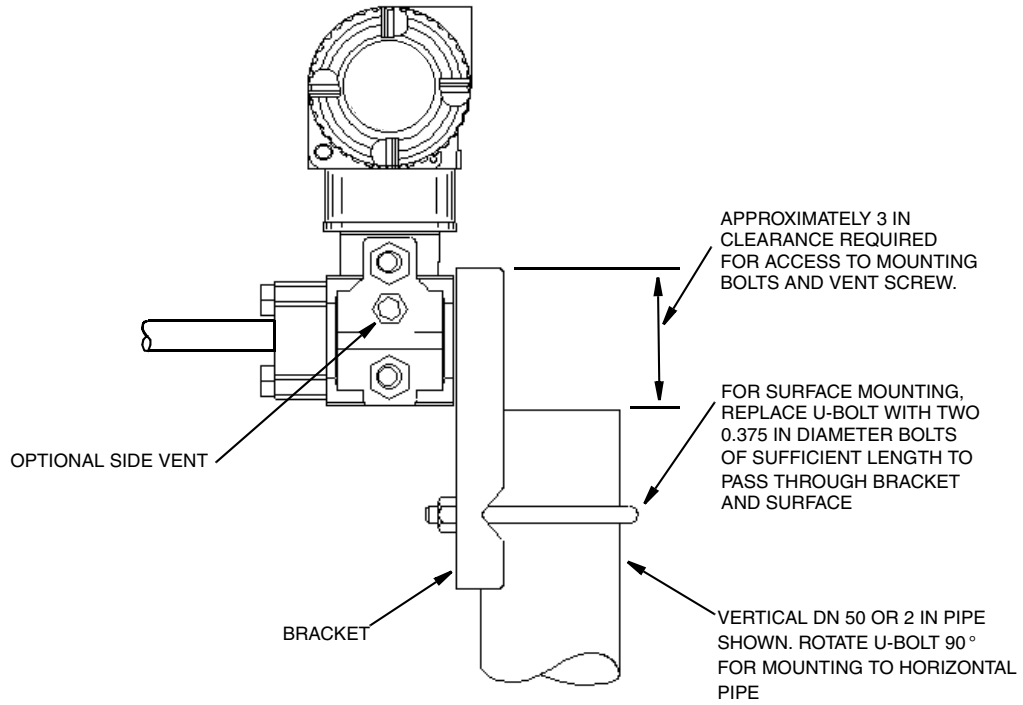

Figure 6. Pipe or Surface Mounted Transmitter Using a Standard Bracket

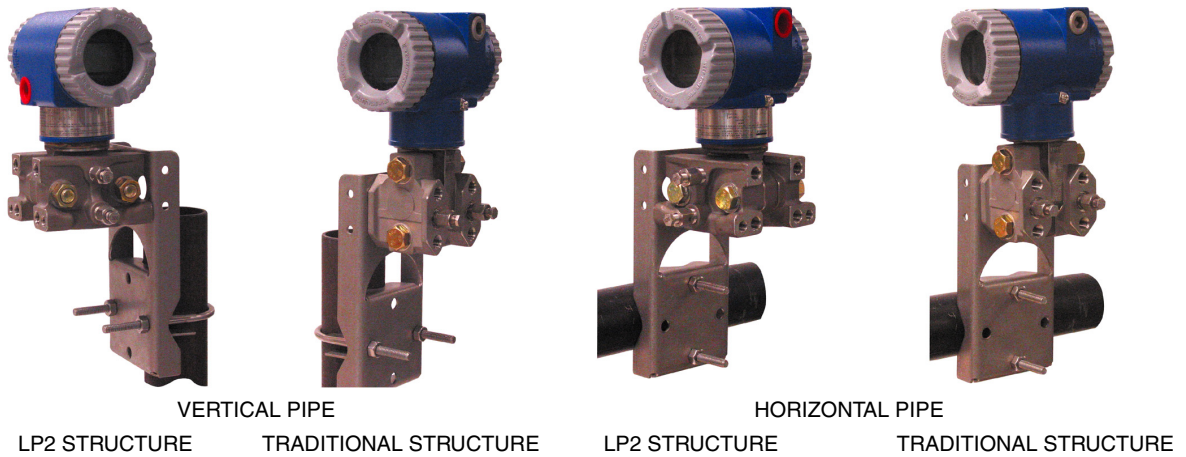

Figure 7. Examples of Mounting With a Standard Bracket

Universal Mounting Bracket

The transmitter (with either traditional or LP2 low-profile structure) can be mounted in a myriad of positions to a vertical or horizontal, DN 50 or 2-in pipe using a universal bracket. See Figure 8 for details of a universal bracket and Figure 9 through Figure 11 for examples of different mounting situations. Secure the mounting bracket to the transmitter using the two long or four short screws provided. Mount the bracket to the pipe. The mounting bracket can also be used for wall mounting by securing the bracket to a wall using the U-bolt mounting holes.

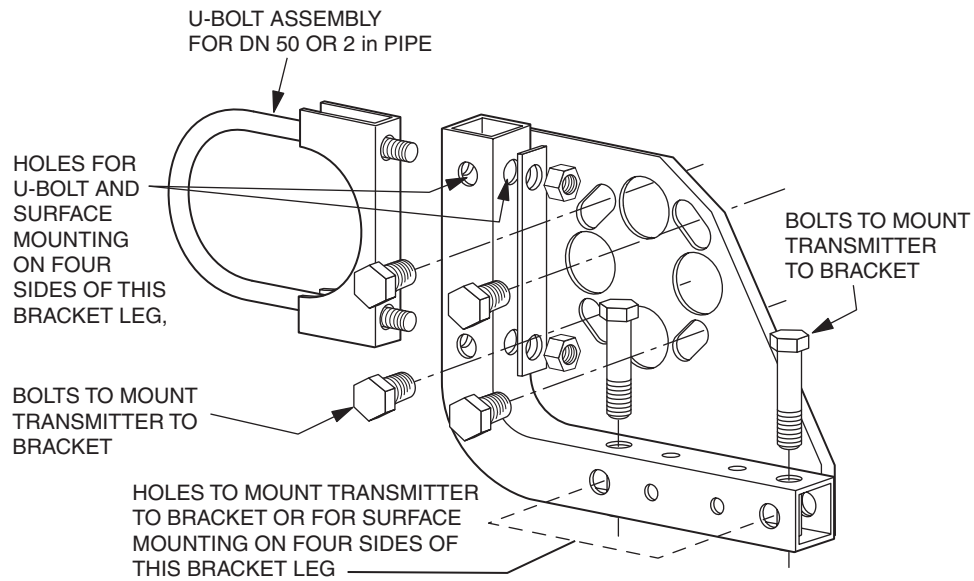

Figure 8. Details of a Universal Bracket

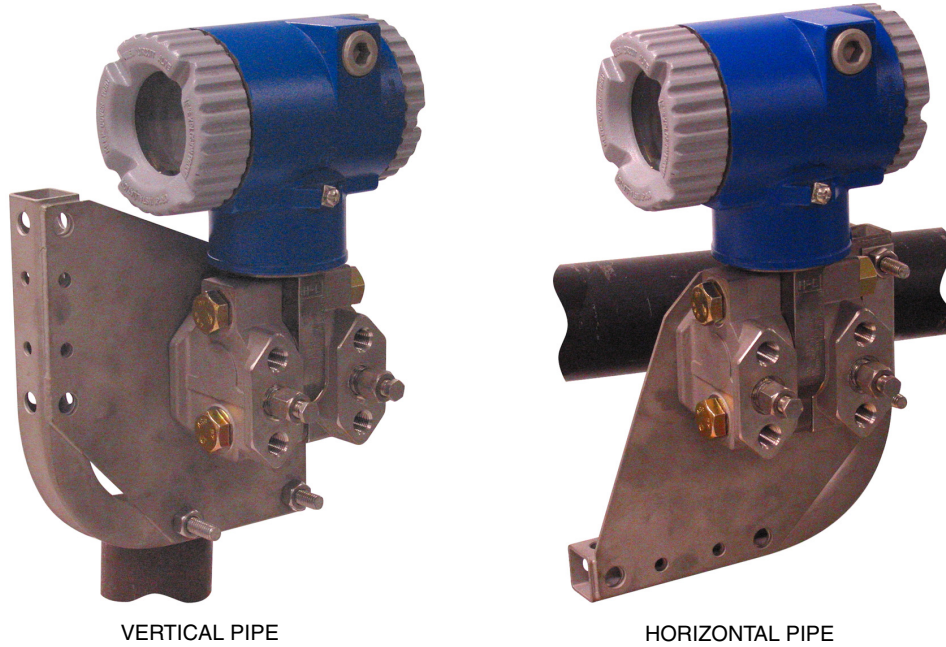

Figure 9. Mounting a Transmitter with Traditional Structure Using a Universal Bracket

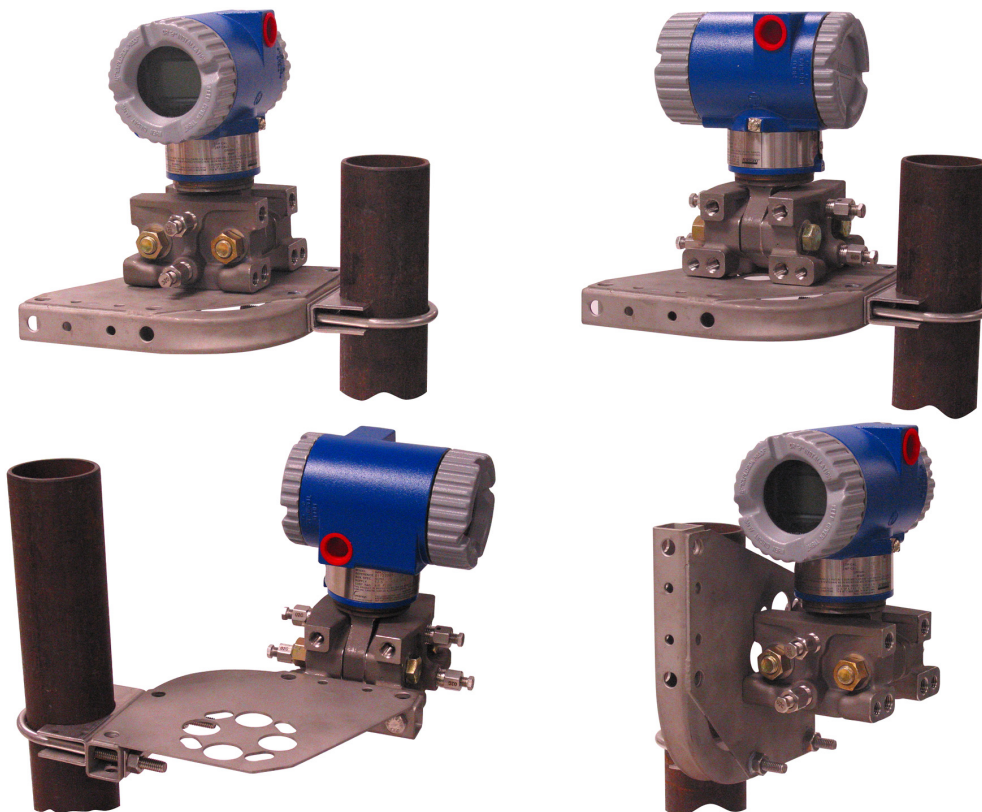

Figure 10. Vertical Pipe Mounting a Transmitter with LP2 Structure Using a Universal Bracket



Figure 11. Horizontal Mounting a Transmitter with LP2 Structure Using a Universal Bracket

Venting and Draining

Traditional Structure

Sensor cavity venting and draining is provided for both vertical and horizontal mounting. For vertical mounted units, draining is via a drain screw shown in Figure 12 and venting is possible with side vents (Option Code -V) shown in Figure 13. For horizontal mounted units, the unit is self draining and venting is via a vent screw shown in Figure 14.

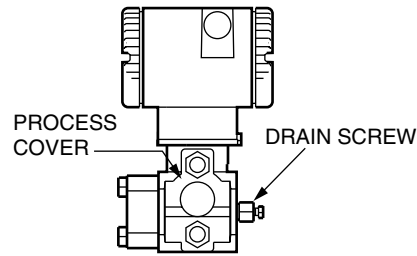

Figure 12. Vertical Mounting - Cavity Draining

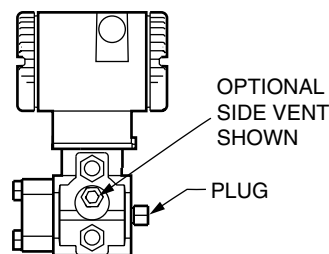

Figure 13. Vertical Mounting - Cavity Venting

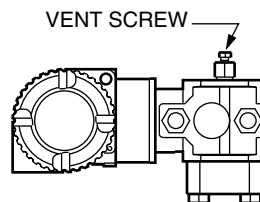

Figure 14. Horizontal Mounting - Cavity Venting

LP1 Low Profile Structure

Sensor cavity venting and draining is provided for both vertical and horizontal mounting. For vertical mounted units, the transmitter is self draining and venting is via a vent screw shown in Figure 15. For horizontal mounted units, the transmitter can simply be 'turned over' (rotated 180 degrees) as shown in Figure 16 to orient the high and low pressure sides in the preferred

locations. There is no need to unbolt the process covers. If the transmitter is connected with a length of impulse piping, such piping should slope up to the transmitter for gas applications and down for liquid applications.

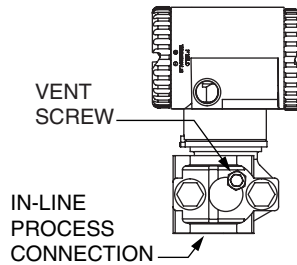

Figure 15. Vertical Mounting - Cavity Venting



Figure 16. Horizontal Mounting - Cavity Venting and Draining

LP2 Low Profile Structure

The transmitter with LP2 low profile structure had a full-featured vent and drain design with separate vent and drain screws positioned in each cover for complete venting and draining from the sensor cavity when installed in the upright position. See Figure 17.

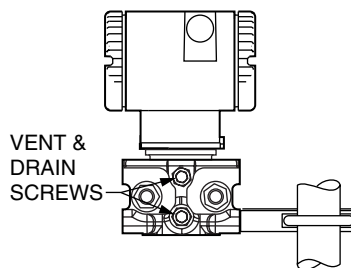

Figure 17. Cavity Venting and Draining

Installation of Flow Measurement Piping

Figure 18 and Figure 19 show typical installations with horizontal and vertical process pipes.

The transmitters are shown below the level of the pressure connections at the pipe (usual arrangement, except for gas flow without a seal liquid), and with filling tees in the lines to the transmitter (for a seal liquid).

If the process fluid being measured must not come in contact with the transmitter, the transmitter lines must be filled with a suitable seal liquid (see procedure in next section). In such a case, the transmitter must be mounted below the level of the pressure connections at the pipe. With steam flow, the lines are filled with water to protect the transmitter from the hot steam. The seal liquid (or water) is added to the lines through the filling tees. To prevent unequal heads on the transmitter, the tees must be at the same elevation (as shown in Figure 18) and the transmitter must be mounted vertically (as shown). If a seal liquid is not required, elbows can be used in place of the tees.

Tighten drain plugs and optional vent screws to 20 N·m (15 lb·ft). Tighten the four process connector bolts to a torque of 61 N·m (45 lb·ft).

Note that the low and high pressure sides of the transmitter are identified by an L-H marking on the side of the sensor above the warning label as shown in Figure 3.

With medium-viscosity seal liquids and/or long transmitter lines, larger valve sizes should be used.

— **NOTE** —

1. With a **horizontal** line, pressure connections at the pipe should be at the side of the line. However, with gas flow without a seal liquid, connections should be at top of line.
 2. With a **vertical** line, flow should be upwards.
 3. For **liquid** or **steam** flow, the transmitter should be mounted **lower** than the pressure connections at the pipe.
 4. For **gas** flow **without** a seal liquid, the transmitter should be mounted **above** the pressure connections at the pipe; for **gas** flow **with** a seal liquid, the transmitter should be mounted **below** the pressure connections.
 5. Invensys recommends the use of snubbers in installations prone to high levels of fluid pulsations.
-

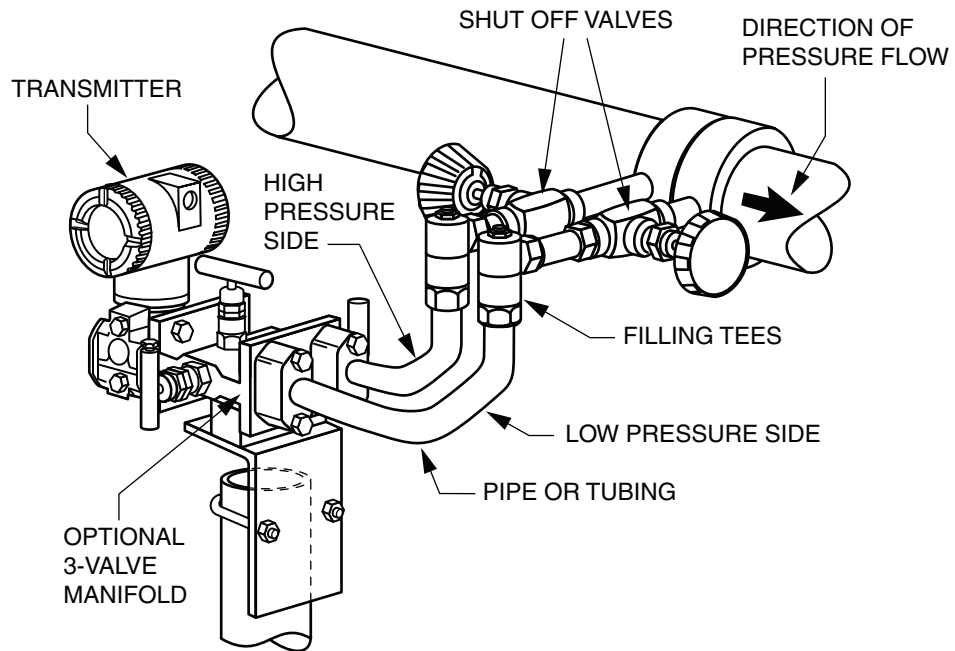

Figure 18. Example of Horizontal Process Line Installation

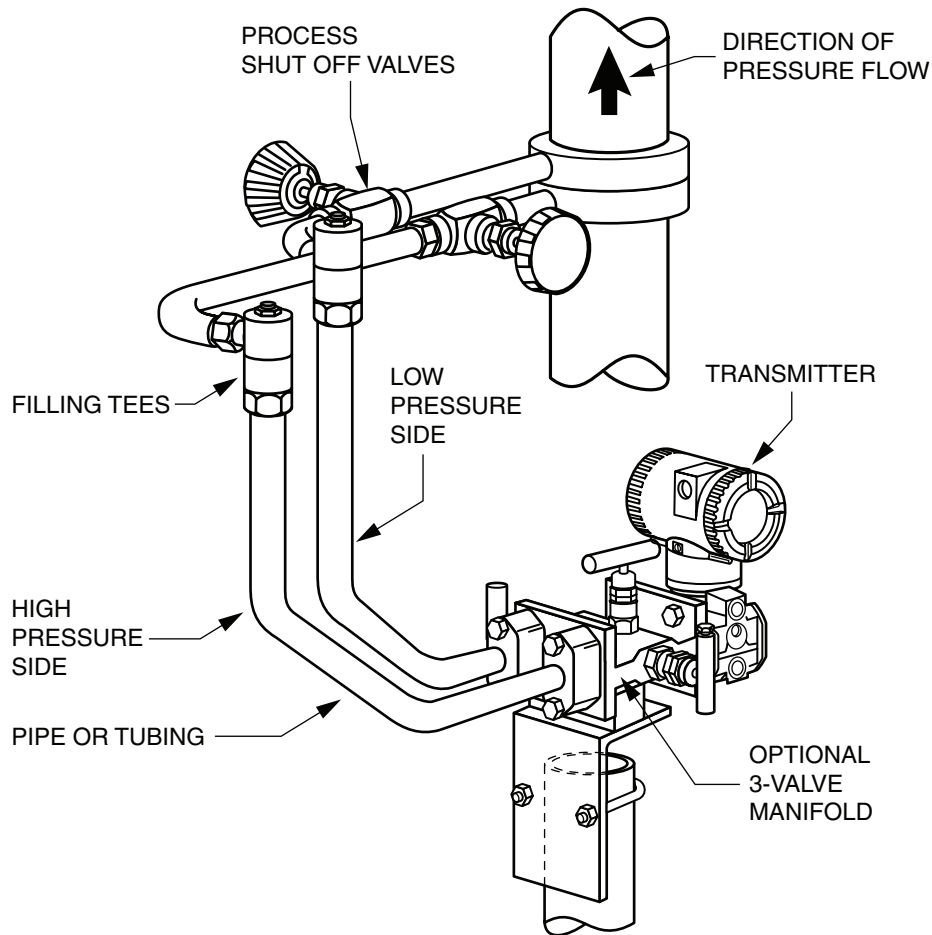

Figure 19. Example of Vertical Process Line Installation

Filling System with Seal Liquid

If the process fluid being measured must not come in contact with the transmitter, the transmitter lines must be filled with a suitable seal liquid. The procedure to do this is as follows:

1. If the transmitter is in service, follow the procedure for “Taking Transmitter out of Operation” on page 34.
2. Close both process shutoff valves.
3. Open all three valves on the 3-valve manifold.
4. Partially open the vent screws on the transmitter until all air has been forced out of the transmitter body and lines. Close the vent screws.
5. Refill the tee connections. Replace the plugs and close the bypass valve. Check for leaks.
6. Follow the procedure for “Putting Transmitter into Operation” on page 33.

! CAUTION

To prevent loss of seal liquid and contamination of process fluid, never open both the process shutoff valves and the manifold shutoff valves if the bypass valve is open.

Positioning Housing

The transmitter housing (topworks) can be rotated up to one full turn in the counterclockwise direction when viewed from above for optimum access to adjustments, display, or conduit connections. Housings have either an anti-rotation screw or a retention clip that prevent the housing from being rotated beyond a safe depth of housing/sensor thread engagement.

! WARNING

If the electronics housing is removed for maintenance, it must be hand tightened to the bottom of the threads, but not over-tightened upon reassembly. See “Removing and Reinstalling a Housing Assembly” on page 74.

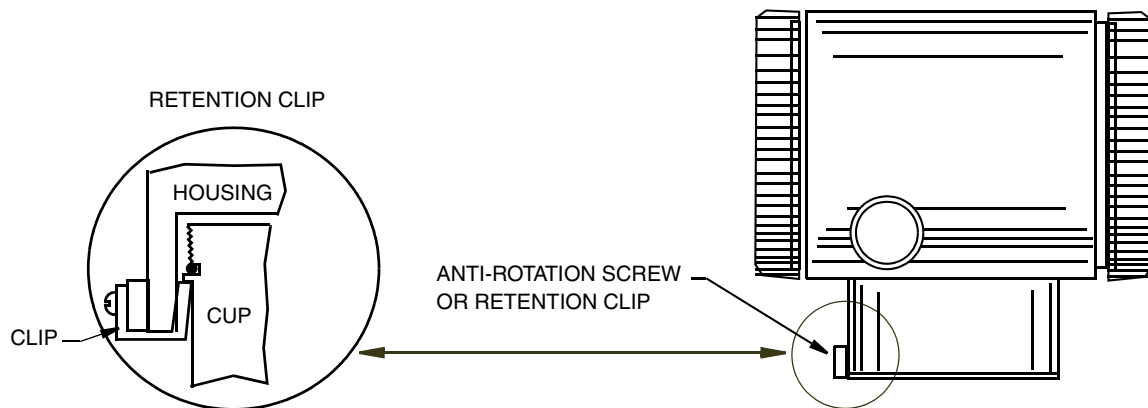

Figure 20. Housing Screw or Clip Location

Positioning Optional Display

The optional display can be rotated within the housing to any of four positions at 90° increments. To do this, grasp the two tabs on the display and rotate it about 10° in a counterclockwise direction. Pull out the display. Ensure that the O-ring is fully seated in its groove in the display housing. Turn the display to the desired position, reinsert it in the electronics module, aligning the tabs on the sides of the assembly, and twist it in the clockwise direction.

! CAUTION

Do not turn the display more than 180° in any direction. Doing so could damage its connecting cable.

Setting the Write Protect Jumper

Your transmitter has write protection capability. This means that the local display and remote communications can be prevented from writing to the electronics. Write protection is set by moving a jumper that is located in the electronics compartment behind the optional display (see Figure 37 on page 73). To activate write protection, remove the display as described in the previous section, then remove the jumper or move it to the lower position as shown on the exposed label. Replace the display.

Cover Locks

Electronic housing cover locks, shown in Figure 21, are provided as standard with certain agency certifications and as part of the Custody Transfer Lock and Seal option. To lock the covers, unscrew the locking pin until approximately 6 mm (0.25 in) shows, lining up the hole in the pin with the hole in the housing. Insert the seal wire through the two holes, slide the seal onto the wire ends and crimp the seal.

Transmitter Wiring

The installation and wiring of your transmitter must conform to local code requirements.

— **NOTE** —

Invensys recommends the use of transient/surge protection in installations prone to high levels of electrical transients and surges.

Accessing Transmitter Field Terminals

For access to the field terminals, thread the cover lock (if present) into the housing to clear the threaded cover and remove the cover from the field terminals compartment as shown in Figure 21. Note that the embossed letters **FIELD TERMINALS** identify the proper compartment. Identification of terminals is shown in Figure 22.

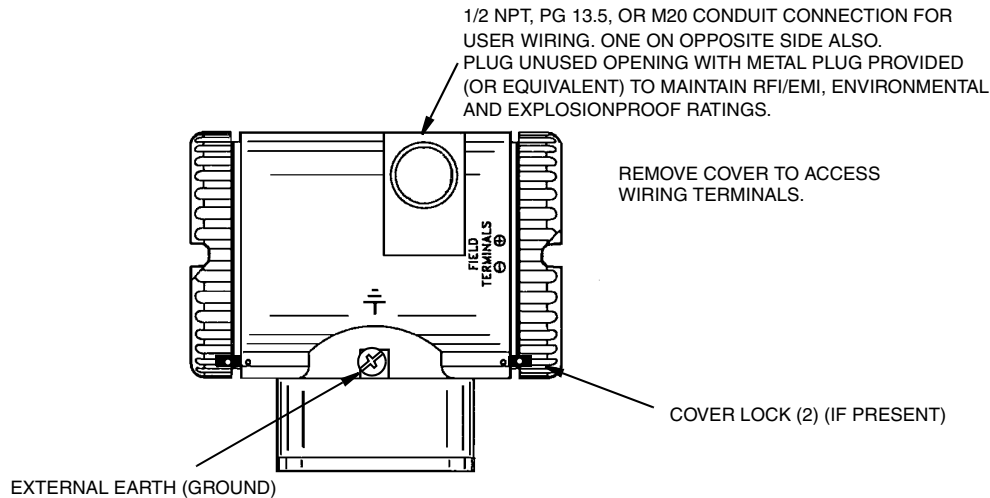

Figure 21. Accessing Field Terminals

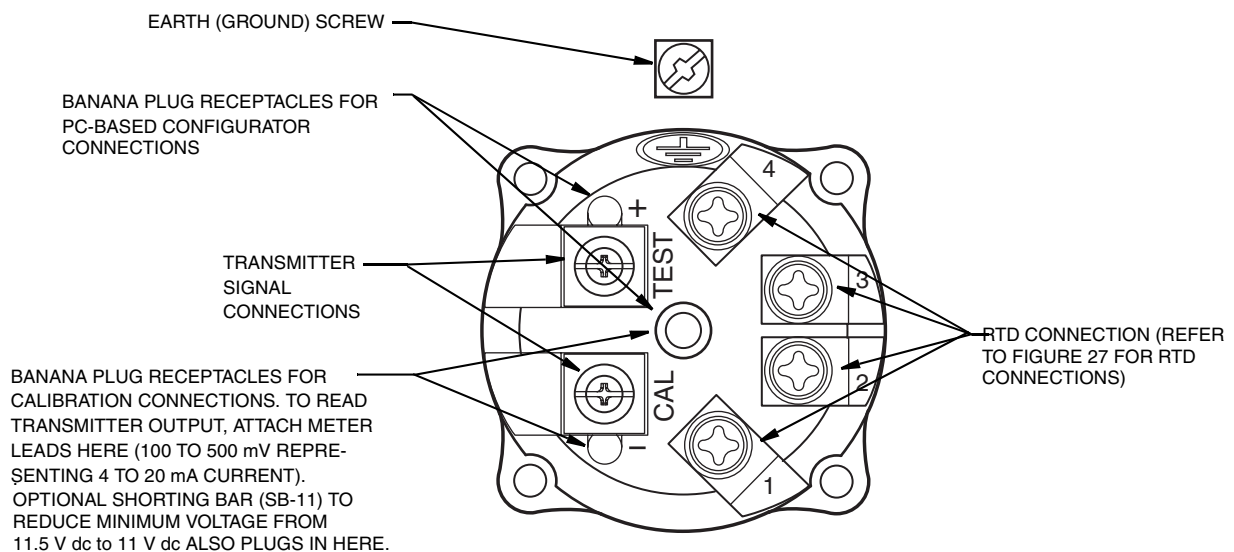

Figure 22. Identification of Field Terminals

Supply Voltage

Power supply must be capable of providing 22 mA when the transmitter is configured for 4 to 20 mA output. Ripple of up to 2 V pp (50/60/100/120 Hz) is tolerable, but instantaneous voltage must remain within specified range.

The supply voltage and loop load must be within specified limits. This is explained in detail in “Wiring the Transmitter To A Loop” on page 28. A summary of the minimum requirements are listed in Table 4.

Table 4. Minimum Loop Load and Supply Voltage Requirements

	Remote Configurator Communication	No Remote Configurator Communication
Minimum Resistance	250 Ω	0
Minimum Supply Voltage	17 V	11.5 V

Electrical Ground Connections

The transmitter is equipped with an internal ground connection within the field wiring compartment and an external ground connection at the base of the electronics housing. To minimize galvanic corrosion, place the wire lead or terminal between the captive washer and loose washer on the external ground screw. If shielded cable is used, earth (ground) the shield at the field enclosure **only**. Do **not** ground the shield at the transmitter.

Wiring the Transmitter

The transmitter can send its measurement to the loop as a continuous 4 to 20 mA dc signal. It also can communicate digitally with a HART Communicator or PC-Based Configurator at distances up to 3050 m or 10000 ft (1525 m or 5000 ft with multidrop communication). Communication between the remote configurator and the transmitter does not disturb the 4 to 20 mA output signal.

The transmitter can be also send its measurement to the I/A Series system as a digital signal via an FBM214/215.

Wiring the Transmitter To A Loop

When wiring a transmitter to a loop, the supply voltage and loop load must be within specified limits. The supply output load vs. voltage relationship is:

$R_{MAX} = 47.5 (V - 11.5)$ and is shown in Figure 23.

— **NOTE** —

The relationship when the optional shorting bar is used is:

$R_{MAX} = 46.8 (V - 11)$.

Any combination of supply voltage and loop load resistance in the shaded area can be used. To determine the loop load resistance (transmitter output load), add the series resistance of each component in the loop, excluding the transmitter. The power supply must be capable of supplying 22 mA of loop current.

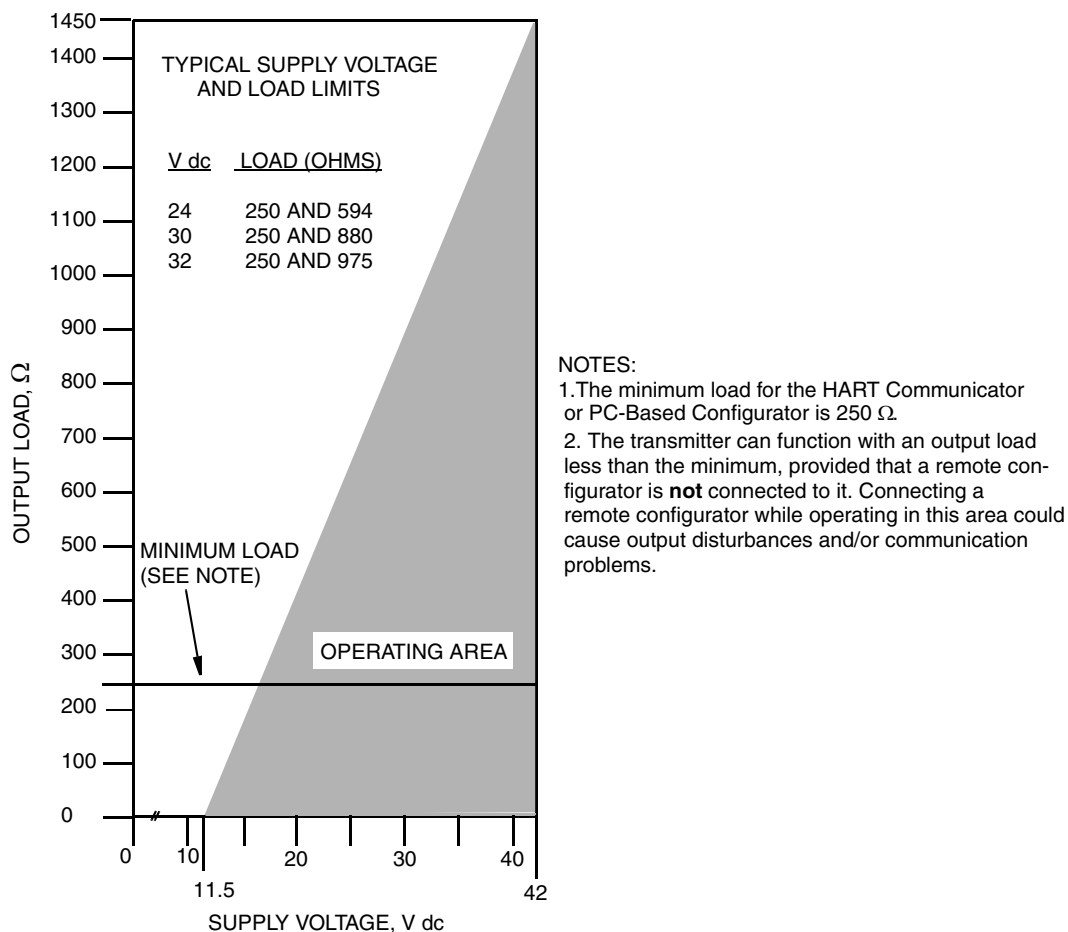

Figure 23. Supply Voltage and Loop Load

Examples:

1. For a loop load resistance of 880 Ω, the supply voltage can be any value from 30 to 42 V dc.
2. For a supply voltage of 24 V dc, the loop load resistance can be any value from 200 to 594 Ω (zero to 594 Ω without a remote configurator connected to the transmitter).

To wire one or more transmitters to a power supply, proceed with the following steps.

1. Remove the cover from the transmitter field terminals compartment.
2. Run signal wires (0.50 mm² or 20 AWG, typical) through one of the transmitter conduit connections as shown in Figure 21. Use twisted pair to protect the 4 to 20 mA output and/or remote communications from electrical noise. Maximum recommended length for signal wires is 3050 m (10000 ft)

NOTE

Do not run transmitter wires in the same conduit as mains (ac power) wires.

3. If shielded cable is used, earth (ground) the shield at the receiver **only**. Do not ground the shield at the transmitter.

4. Plug unused conduit connection with the 1/2 NPT, PG 13.5, or M20 metal plug provided (or equivalent). To maintain specified explosionproof and dust-ignitionproof protection, plug must engage a **minimum** of five full threads for 1/2 NPT connections; seven full threads for M20 and PG 13.5 connections.
5. Connect an earth (ground) wire to the earth terminal in accordance with local practice.

— **! CAUTION** —

If the signal circuit must be earthed (grounded), it is preferable to do so at the negative terminal of the dc power supply. To avoid errors resulting from earth loops or the possibility of short-circuiting groups of instruments in a loop, there should be only one earth in a loop.

6. Connect the power supply and receiver loop wires to the “+” and “–” terminal connections shown in Figure 22.
7. Connect receivers (such as controllers, recorders, indicators) in series with power supply and transmitter as shown in Figure 24.
8. Install the cover onto the transmitter. Turn the cover to seat the O-Ring into the housing and continue to hand tighten until the cover contacts the housing metal-to-metal. If cover locks are present, refer to “Cover Locks” on page 26.
9. The HART Communicator or PC-Based Configurator can be connected in the loop between the transmitter and the power supply as shown in Figure 24. Note that a minimum of 250 Ω must separate the power supply from the remote configurator.

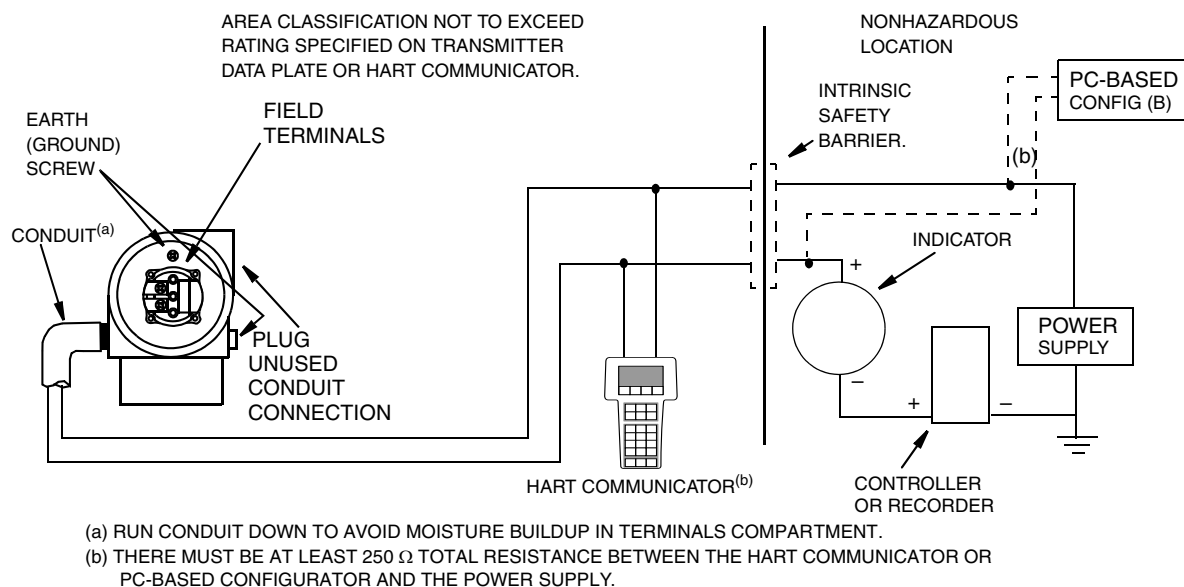

Figure 24. Loop Wiring Transmitters

Multidrop Communication

“Multidropping” refers to the connection of several transmitters to a single communications transmission line. Communications between the host computer and the transmitters takes place

digitally with the analog output of the transmitter deactivated. With the HART communications protocol, up to 15 transmitters can be connected on a single twisted pair of wires or over leased telephone lines.

The application of a multidrop installation requires consideration of the update rate necessary from each transmitter, the combination of transmitter models, and the length of the transmission line. Multidrop installations are not recommended where Intrinsic Safety is a requirement. Communication with the transmitters can be accomplished with any HART compatible modem and a host implementing the HART protocol. Each transmitter is identified by a unique address (1-15) and responds to the commands defined in the HART protocol.

Figure 25 shows a typical multidrop network. Do **not** use this figure as an installation diagram. Contact the HART Communications Foundation, (512) 794-0369, with specific requirements for multidrop applications.

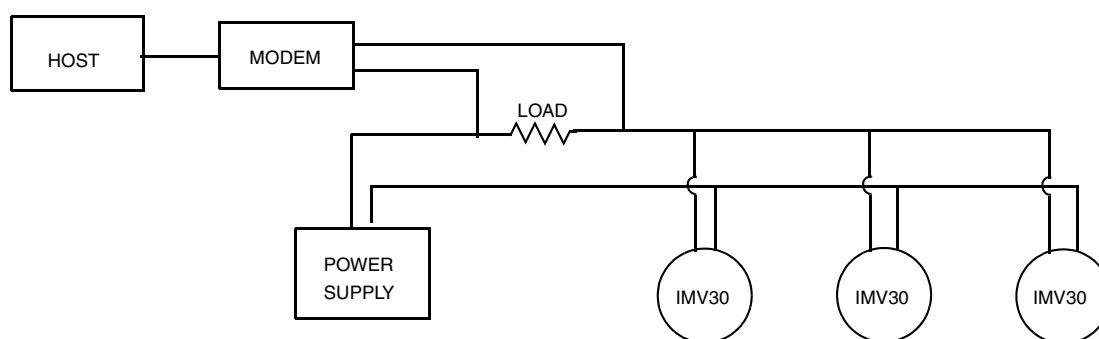

Figure 25. Typical Multidrop Network

The HART Communicator can operate, configure, and calibrate IASPT transmitters with HART communication protocol in the same way as it can in a standard point-to-point installation.

— NOTE —

IASPT transmitters with HART communication protocol are set to poll address 0 (**POLLADR 0**) at the factory, allowing them to operate in the standard point-to-point manner with a 4 to 20 mA output signal. To activate multidrop communication, the transmitter address must be changed to a number from 1 to 15. Each transmitter must be assigned a unique number on each multidrop network. This change deactivates the 4 to 20 mA analog output.

Connecting the Transmitter To an I/A Series System

The transmitter can also send its measurement to the I/A Series system as a digital signal via an FBM214/215. The following procedure identifies wire terminations in the transmitter. For other system wiring details, refer to the installation instructions provided with the I/A Series system.

1. Remove the cover from the transmitter field terminal compartment.
2. Run signal wires (0.50 mm² or 20 AWG, typical) through one of the transmitter conduit connections as shown in Figure 26. Use twisted pair to protect the digital output and/or remote communications from electrical noise. Screened (shielded) cable may be required in some locations.

— NOTE

Do **not** run transmitter wires in the same conduit as mains (ac power) wires.

3. If shielded cable is used, earth (ground) the shield at the field enclosure **only**. Do not ground the shield at the transmitter.
4. Plug unused conduit connection with the 1/2 NPT, PG 13.5, or M20 metal plug provided (or equivalent). To maintain specified explosionproof and dust-ignitionproof protection, plug must engage a **minimum** of five full threads for 1/2 NPT connections; seven full threads for M20 and PG 13.5 connections.

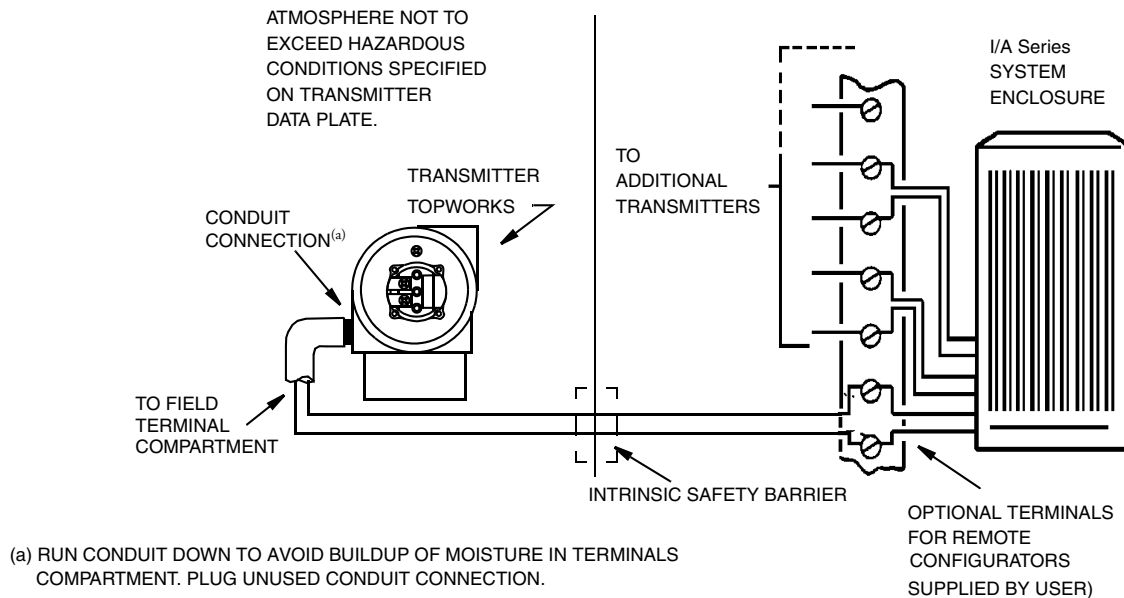

Figure 26. Typical Transmitter Wiring to an I/A Series System

5. Connect an earth (ground) wire to the earth terminal in accordance with local practice. Ground terminal is shown in Figure 22.

— ! CAUTION

To avoid errors resulting from earth loops or the possibility of short-circuiting groups of instruments in a loop, use only one earth in a loop.

6. Connect the signal wires to the transmitter “+” and “-” terminal connections shown in Figure 22.
7. The HART Communicator or PC-Based Configurator can be connected via banana plugs to the top two receptacles (designated **TEST**) on the terminal block in the field terminal compartment as shown in Figure 22 or any other convenient location in the loop (subject to hazardous location restrictions).
8. Reinstall the cover on the transmitter. Turn the cover to seat the O-Ring into the housing and continue to hand tighten until the cover contacts the housing metal-to-metal. If cover locks are present, refer to “Cover Locks” on page 26.

Connecting the RTD

— **! WARNING** —

For CE compliance, metallic conduit is required between the transmitter and the RTD. Invensys recommends the use of metallic conduit for all installations.

Connect your RTD to terminals 1, 2, 3 and 4. Locations are shown in Figure 22. Wire per Figure 27.

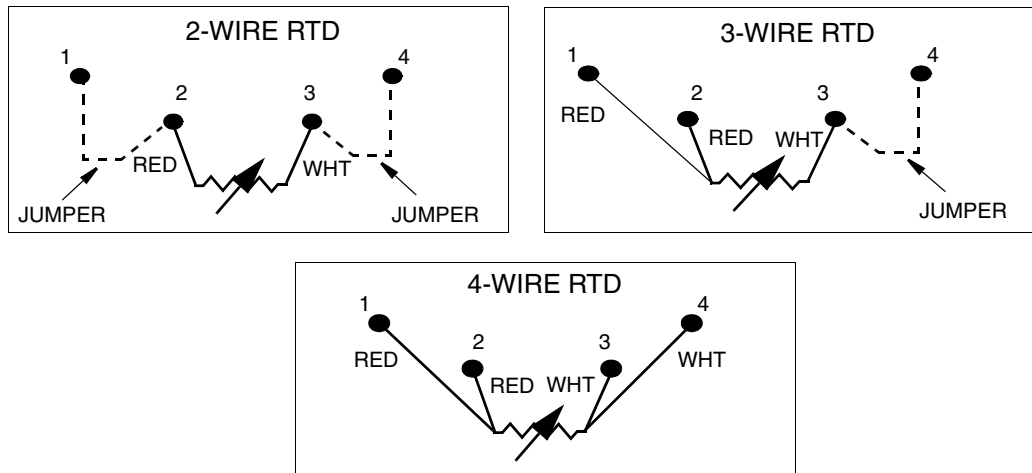

Figure 27. RTD Wiring

— **NOTE** —

Only a 4-wire RTD is compensated for by the transmitter and thus yields the most accurate measurement.

Putting Transmitter into Operation

The following procedure explains how to sequence the valves in your flow measurement piping or optional bypass manifold to ensure that your transmitter is not overranged and that seal liquid is not lost. Refer to Figure 18 or Figure 19.

— **NOTE** —

This procedure assumes that process shutoff valves are open.

1. Make sure that both upstream and downstream manifold valves are closed.
2. Make sure that the bypass valve is open.
3. Slowly open the upstream manifold valve.
4. Close the bypass valve.
5. Slowly open the downstream manifold valve.

Taking Transmitter out of Operation

The following procedure explains how to sequence the valves in your flow measurement piping or optional bypass manifold to ensure that your transmitter is not overranged and that seal liquid is not lost. Refer to Figure 18 or Figure 19.

— **NOTE** —

This procedure assumes that Process shutoff valves are open.

1. Close the downstream manifold valve.
2. Close the upstream manifold valve.
3. Open the bypass valve.
4. Carefully open the vent screw to release any residual pressure before disconnecting lines.

—  **WARNING** —

When venting pressure from the transmitter, wear suitable protective equipment to prevent possible injury from process material, temperature, or pressure.

3. Calibration and Configuration

— **NOTE** —

1. For best results in applications where high accuracy is required, rezero the transmitter output once it has stabilized at the final operating temperature.
 2. Zero shifts resulting from position effects and/or static pressure effects can be eliminated by rezeroing the transmitter output.
 3. When checking the zero reading of a transmitter operating in the square root mode, return the output to the linear mode. This eliminates an apparent instability in the output signal. Return the transmitter output to the square root mode after the zero check is complete.
 4. After calibrating transmitters operating with a 4 to 20 mA output signal, check the underrange and overrange output values to ensure that they extend beyond 4 and 20 mA respectively.
-

Calibration Setup

This section shows setups for field or bench calibration. Use test equipment that is at least three times as accurate as the desired accuracy of the transmitter.

— **NOTE** —

It is not necessary to set up calibration equipment to rerange the transmitter to a different range. The transmitter can be accurately reranged by simply changing the Lower Range Value and the Upper Range Value, which are stored in the transmitter database.

Field calibration is performed without disconnecting the process piping. In order to do this, you must have a bypass and shutoff valves between the process and the transmitter and one of the following:

- ◆ Access to the process connections on the nonprocess side of the transmitter or
- ◆ The optional vent screw in the side of the process covers.

An adjustable air supply and a pressure measuring device are required. For example, a dead weight tester or an adjustable clean air supply and pressure gauge can be used. The pressure source can be connected to the transmitter process connection with pipe fittings or it can be connected to the vent screw assembly using a calibration screw. The calibration screw has a Polyflo fitting and can be used for pressures up to 700 kPa (100 psi). It is available as Foxboro Part Number F0101ES. |

To set up the equipment, refer to Figure 28 or Figure 29 and use the following procedure.

1. If the transmitter is in operation, follow the procedure on “Taking Transmitter out of Operation” on page 34.

— **! CAUTION** —

With liquid service, drain both sides of transmitter to avoid calibration errors.

2. If a calibration screw is being used, remove the vent screw and replace it with the calibration screw. Connect the pressure source to the calibration screw using 6 x 1 mm or 0.250 inch tubing.
If a calibration screw is **not** being used, remove the entire vent screw assembly or drain plug (as applicable) from the high pressure side of the transmitter. Connect calibration tubing using a suitable thread sealant.
3. Close the bypass valve opened in Step 1.
4. Complete the setup shown in Figure 28 for differential pressure calibration and Figure 29 for absolute pressure calibration.

— **NOTE** —

For vacuum applications, connect the calibrating pressure source to the low pressure side of the transmitter.

5. If you are calibrating the 4 to 20 mA output signal, also connect the electronic equipment as shown in Figure 30.

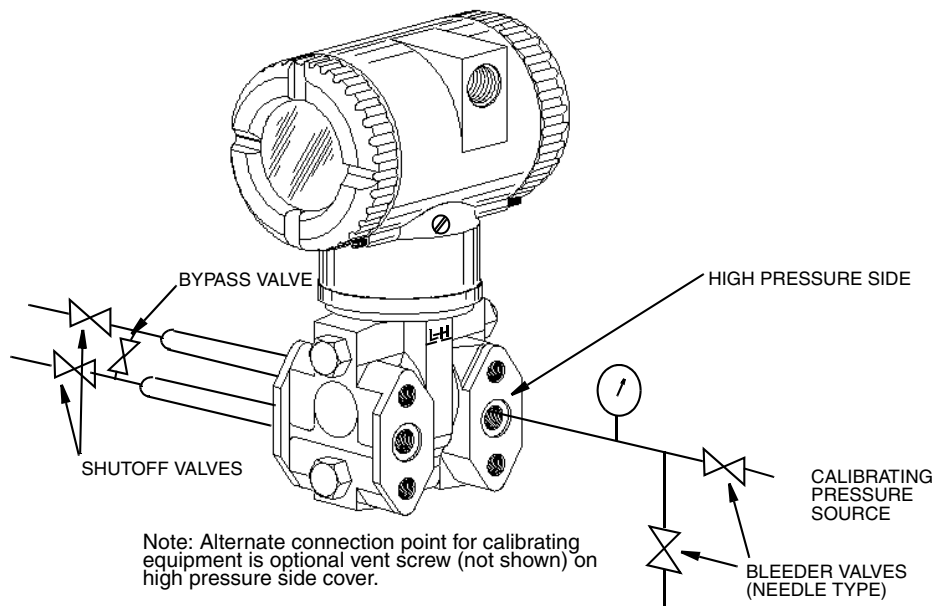

Figure 28. Setup for Differential Pressure Calibration

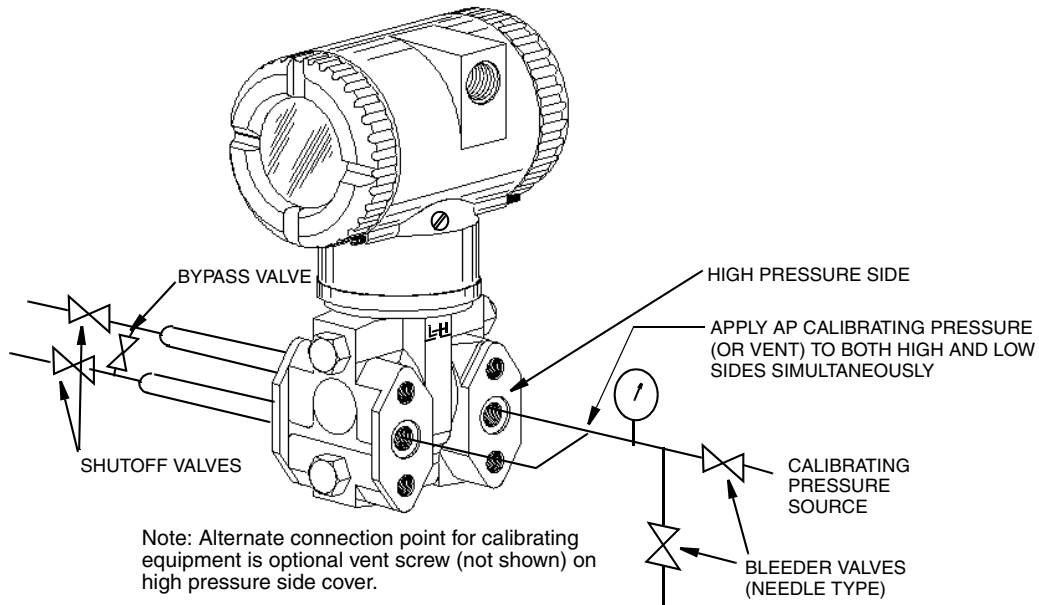
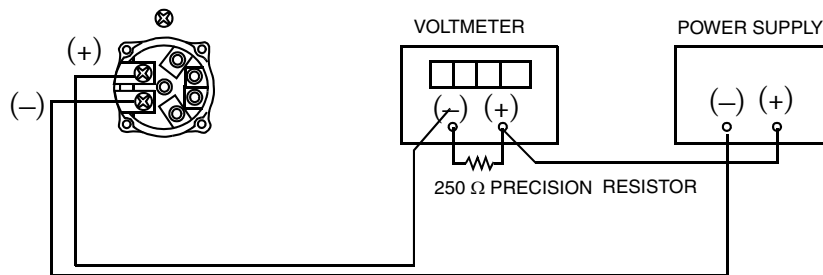

Figure 29. Setup for Absolute Pressure Calibration



Resistor: 250 Ω , $\pm 0.01\%$, 1 W minimum (Part No. E0309GY)
 Power Supply: Refer to Figure 23
 Digital Voltmeter: readings from 1.000 to 5.000 V dc

Figure 30. 4 to 20 mA Output Calibration Setup

Configurable Parameters

Table 5 lists all of the configurable parameters and the factory default for the IMV30 Transmitter. The factory default values have been customized if the transmitter was ordered with optional feature -C1 or -C2. The table also shows which parameters are configurable with the integral vs. remote configurators.

Table 5. Configurable Parameters

Parameter	Capability	Factory Default ^(a)	Configurable with		
			Integral Indicator	Remote Config.	HART Comm.
Poll Address	0 - 15	0	Yes	Yes	Yes
Descriptors					
Tag Number	8 characters max	- - -	No	Yes	Yes
Descriptor	16 characters max	- - -	No	Yes	Yes
Message	32 characters max	- - -	No	Yes	Yes
Dynamic Variable Assignment					
Primary Measurement/Calculation	D/P, A/P, RTD, Flow, Density, Sensor Temp, Electronics Temp ^(b)	D/P	Yes	Yes	Yes
Secondary Measurement/Calculation	D/P, A/P, RTD, Flow, Density, Sensor Temp, Electronics Temp ^(b)	A/P	Yes	Yes	Yes
Tertiary Measurement/Calculation	D/P, A/P, RTD, Flow, Density, Sensor Temp, Electronics Temp ^(b)	STMP	Yes	Yes	Yes
Fourth Measurement/Calculation	D/P, A/P, RTD, Flow, Density, Sensor Temp, Electronics Temp ^(b)	RTD	Yes	Yes	Yes
mA					
Direction	Forward or Reverse	Forward	Yes	No	No
Failsafe	Fail mode output - High or Low	High	Yes	Yes	No
Offline	Offline output - last value or user set from 3.75 to 21 mA	User set at 4 mA	Yes	No	No
D/P					
Mode ^(c)	Linear or Type of Sq Rt	Linear	Yes	Yes	Yes
Units	Pressure units for Linear, % for Sq Rt	inH ₂ O	Yes	Yes	Yes
D/P LRV	Within D/P range	0	Yes	Yes	Yes
D/P URV	Within D/P range	URL	Yes	Yes	Yes
Damping	0 to 32 seconds	None	Yes	Yes	Yes
A/P					
Mode	Display AP or GP	AP	Yes	Yes	Yes
Units	Pressure units	psia	Yes	Yes	Yes
A/P LRV	Within A/P range	0	Yes	Yes	Yes
A/P URV	Within A/P range	URL	Yes	Yes	Yes
ATM Reference	Pressure value	14.7 psi	Yes	Yes	Yes
Damping	0 to 32 seconds	None	Yes	Yes	Yes
RTD					
Mode	On or Off	On	Yes	Yes	Yes
Units	Temperature Units	deg C	Yes	Yes	Yes

Table 5. Configurable Parameters (Continued)

Parameter	Capability	Factory Default ^(a)	Configurable with		
			Integral Indicator	Remote Config.	HART Comm.
RTD LRV	Within RTD range	-200	Yes	Yes	Yes
RTD URV	Within RTD range	+850	Yes	Yes	Yes
RTD Strategy for Flow and Density	Never Use Default Use Default on Failure Use SatSteam Always Use Default	Never Use Default	No	Yes	Yes
RTD Default Value		26	Yes	Yes	Yes
Flow (IMV30 only) ^(d)					
Mode ^(b)	On or Off	On	Yes	Yes	Yes
Units	Flow Units	kg/s	Yes	Yes	Yes
Flow LRV	Within flow limits	0	Yes	Yes	Yes
Flow URV	Within flow limits	10	Yes	Yes	Yes
Noise Reduction	On or Off		No	Yes	Yes
Flow Cutoff		0	No	Yes	Yes
Density (IMV30 only) ^(d)					
Mode	On or Off	On	Yes	Yes	Yes
Units	Density Units	lb/ft ³	Yes	Yes	Yes
Density LRV	Within density limits	59.6	Yes	Yes	Yes
Density URV	Within density limits	62.9	Yes	Yes	Yes
Sensor Temperature					
Units	Temperature Units	deg C	No	Yes	Yes
STMP LRV	Within STMP limits	-40	No	Yes	Yes
STMP URV	Within STMP limits	+122	No	Yes	Yes
Electronics Temperature					
Units	Temperature Units	deg C	No	Yes	Yes
ETMP LRV	Within ETMP limits	-40	No	Yes	Yes
ETMP URV	Within ETMP limits	+85	No	Yes	Yes
Other					
Enable Passwords for local display pushbuttons	No password, Configuration only locked, or Calibration and Configuration locked	No Password	Yes	Yes	Yes
Reset Database	Keep or Clear	Keep	Yes	No	Yes

(a) Per Sales order if custom configuration option -C2 has been specified

(b) Flow and density on IMV30 only.

(c) D/P Mode cannot be configured as a type of square root when Flow is configured On.
Flow cannot be configured On when D/P Mode is configured as a type of square root.

(d) Numerous additional flow and density configuration parameters must be set using the PC-Based configurator.

Calibration and Configuration Using a PC-Based Configurator

To calibrate or configure the transmitter using a PC-Based Configurator, follow the procedures in MI 020-496.

Calibration and Configuration Using a HART Communicator

— NOTE —
 You can configure many parameters using a HART Communicator. However, for more complete configuration capability, including flow and density configuration, use a PC-Based Configurator.

Online Menu

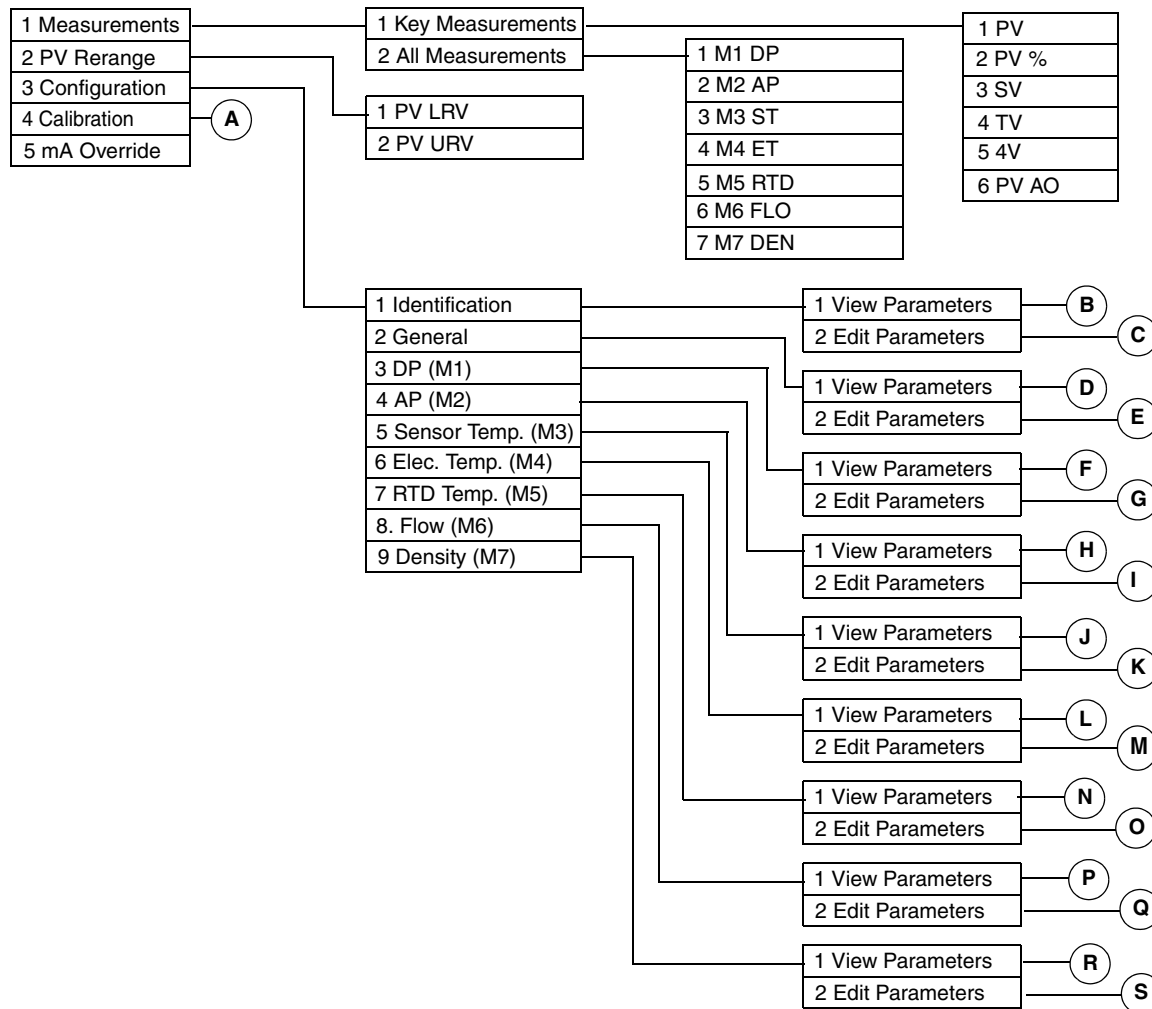

Figure 31. HART Communicator Online Menu (1 of 2)

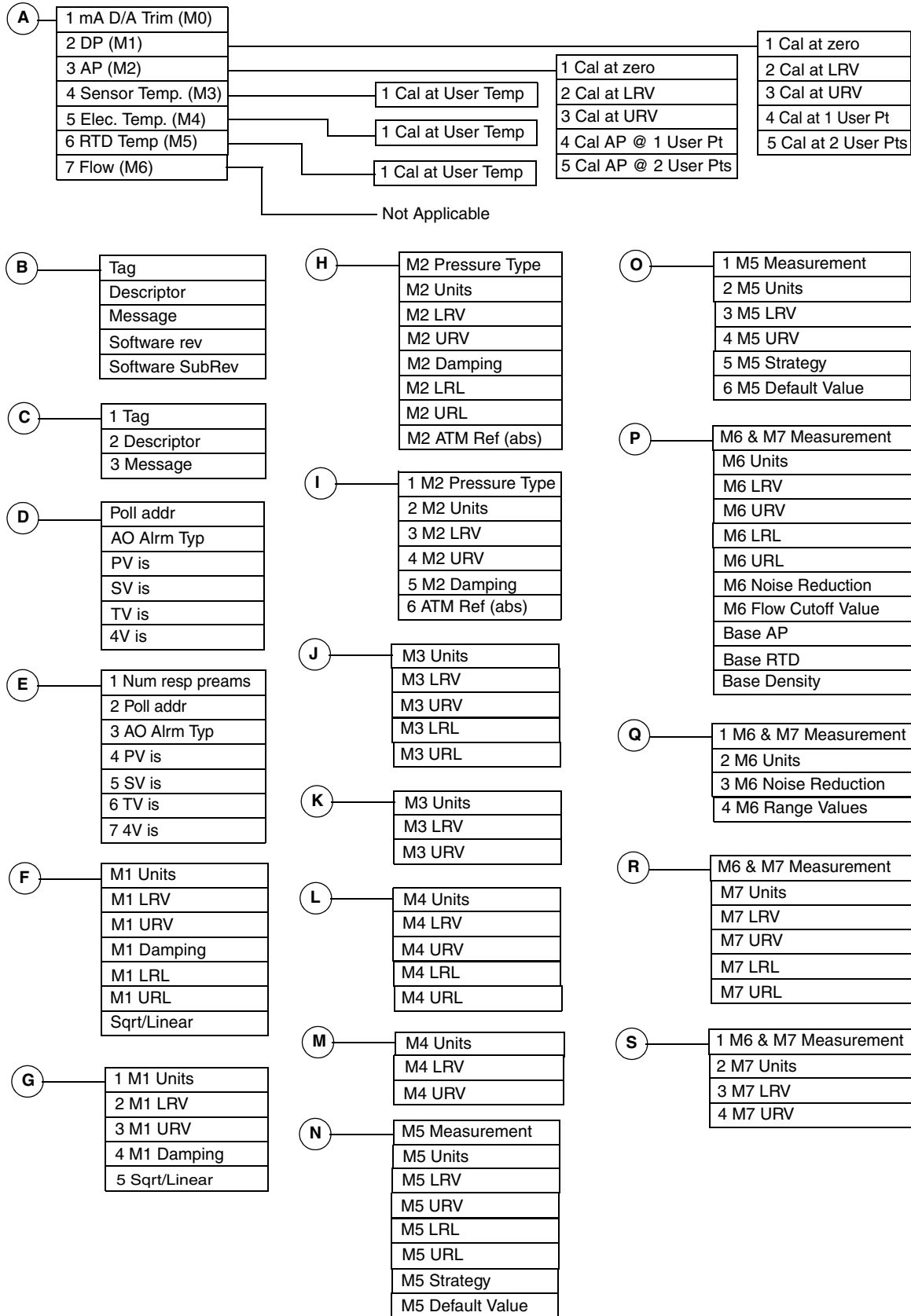

Figure 32. HART Communicator Online Menu (2 of 2)

Explanation of Parameters

Parameter	Fast-Key Path	Explanation
4V	1,1,5	Shows the value of fourth variable.
4V is	3,2,2,7	Select M1 DP, M2 AP, M3 Sens Temp, M4 Elec Temp, M5 RTD, M6 Flow, or M7 Density.
All Measurements	1,2	Path to reading all measurements.
AO Alrm Typ	3,2,2,3	Select Hi or Lo.
AP (M2)	4,3	Path to pressure calibration procedures.
AP (M2)	3,4	Path to viewing or editing absolute pressure parameters.
Base AP	3,8,1	Path to view the base absolute pressure value.
Base Density	3,8,1	Path to view the base density value.
Base RTD	3,8,1	Path to view the base RTD value.
Cal at 1 User Pt	4,2,4	Differential pressure calibration at 1 user determined point.
Cal at 1 User Pt	4,3,4	Pressure calibration at 1 user determined point.
Cal at 2 User Pts	4,2,5	Differential pressure calibration at 2 user determined points.
Cal at 2 User Pts	4,3,5	Pressure calibration at 2 user determined points.
Cal at ATM	4,3,1	Pressure calibration at atmospheric pressure.
Cal at LRV	4,2,2	Differential pressure calibration at the lower range value.
Cal at LRV	4,3,2	Pressure calibration at the lower range value.
Cal at URV	4,2,3	Differential pressure calibration at the upper range value.
Cal at URV	4,3,3	Pressure calibration at the upper range value.
Cal at User Temp	4,4,1 4,5,1 4,6,1	Calibration procedure for Sensor Temp. (M3). Calibration procedure for Electronic Temp. (M4). Calibration procedure for RTD Temp. (M5).
Cal at zero	4,2,1	Differential pressure calibration at zero pressure differential.
Calibration	4	Path to calibration procedures.
Configuration	3	Path to view or edit all parameters.
Density (M7)	3,9	Path to viewing or editing density parameters.
Descriptor	3,1,2,2	Edit Descriptor information.
DP (M1)	3,3	Path to viewing or editing differential pressure parameters.
DP (M1)	4,2	Path to differential pressure calibration procedures.
Edit Parameters	3,1,2 3,2,2 3,3,2 3,4,2 3,7,2 3,8,2 3,9,2	Edit identification parameter data Edit general parameter data. Edit differential pressure parameter data. Edit absolute pressure parameter data. Edit temperature parameter data. Edit flow parameter data Edit density parameter data.

Parameter	Fast-Key Path	Explanation
Elec. Temp. (M4)	3,6	Not used
Elec. Temp. (M4)	4,5	Electronic temperature calibration procedure.
Flow (M6)	3,8	Path to viewing or editing flow parameters.
Flow (M6)	4,7	Path to flow calibration procedures.
General	3,2	Path to configuring poll address, AO Alarm type, and process variables.
Identification	3,1	Path to identification parameters.
Key Measurements	1,1	Path to reading key measurements.
M1 Damping	3,3,2,4	Enter the differential pressure damping value in seconds.
M1 DP	1,2,1	Shows the differential pressure measurement.
M1 LRL	3,3,1	Path to view the differential pressure lower range limit.
M1 LRV	3,3,2,2	Enter the differential pressure lower range value.
M1 Sqrt/Linear	3,3,2,5	Enter the differential pressure mode
M1 Units	3,3,2,1	Select the differential pressure unit.
M1 URL	3,3,1	Path to view the differential pressure upper range limit.
M1 URV	3,3,2,3	Enter the differential pressure upper range value.
M2 AP	1,2,2	Shows the absolute pressure measurement.
M2 ATM Ref (abs)	3,4,2,6	Enter the ambient atmospheric pressure. ^(a)
M2 Damping	3,4,2,5	Enter the absolute pressure damping value in seconds.
M2 LRL	3,4,1	Path to view the absolute pressure lower range limit.
M2 LRV	3,4,2,3	Enter the absolute pressure lower range value.
M2 Pressure Type	3,4,2,1	Select Absolute or Gauge.
M2 Units	3,4,2,2	Select the absolute pressure unit.
M2 URL	3,4,1	Path to view the absolute pressure upper range limit.
M2 URV	3,4,2,4	Enter the absolute pressure upper range value.
M3 LRV	3,5,2,2	Enter the sensor temperature lower range value.
M3 ST	1,2,3	Shows the sensor temperature measurement.
M3 Units	3,5,2,1	Select the sensor temperature unit.
M3 URV	3,5,2,3	Enter the sensor temperature upper range value.
M3 LRL	3,5,1	Path to view the sensor temperature lower range limit.
M3 URL	3,5,1	Path to view the sensor temperature upper range limit.
M4 ET	1,2,4	Shows the electronic temperature measurement.
M4 LRL	3,6,1	Path to view the electronics temperature lower range limit.
M4 LRV	3,6,2,2	Enter the electronics temperature lower range value.
M4 Units	3,6,2,1	Select the electronics temperature unit.
M4 URL	3,6,1	Path to view the electronics temperature upper range limit.
M4 URV	3,6,2,3	Enter the electronics temperature upper range value.
M5 Default Value	3,7,2,6	Enter Default value.
M5 LRL	3,7,1	Path to view the RTD temperature lower range limit.
M5 LRV	3,7,2,3	Enter the RTD lower range value.

Parameter	Fast-Key Path	Explanation
M5 Measurement	3,7,2,1	Select On or Off.
M5 RTD	1,2,5	Shows the RTD measurement.
M5 Strategy	3,7,2,5	Select Never Use Default or Use Def. on RTD Fail.
M5 Units	3,7,2,2	Select Kelvin, degC, degF, or degR.
M5 URL	3,7,1	Path to view the RTD temperature upper range limit.
M5 URV	3,7,2,4	Enter the RTD upper range value.
M6 FLO	1,2,6	Shows the flow measurement.
M6 LRL	3,8,1	Path to view the flow lower range limit.
M6 Flow Cutoff Value	3,8,1	Path to view the flow cutoff value
M6 & M7 Measurement	3,8,2,1 3,9,2,1	Select On or Off.
M6 Noise Reduction	3,8,2,3	Select On or Off
M6 Range Values	3,8,2,4	Path to entering the flow lower and upper range values.
M6 Units	3,8,2,2	Select the flow unit.
M6 URL	3,8,1	Path to view the flow upper range limit.
M7 DEN	1,2,7	Shows the density measurement.
M7 LRL	3,9,1	Path to view the density lower range limit.
M7 LRV	3,9,2,3	Enter the density lower range value.
M7 Units	3,9,2,2	Select the density unit.
M7 URL	3,9,1	Path to view the density upper range limit.
M7 URV	3,9,2,4	Enter the density upper range value
mA D/A Trim	4,1	Calibration procedure to match the 4-20 mA output to the calibration of the receiving device.
mA Override	5	Enter mA override value (3.6 to 21 mA)
Measurements	1	Path to all measurements.
Message	3,1,2,3	Edit Message information.
Num resp preams	3,2,2,1	Enter number of preambles to be sent in a response message from the transmitter.
Poll addr	3,2,2,2	Specify 0 in standard point to point,2-wire analog mode. Specify an address from 1 through 15 for multidrop operation.
PV	1,1,1	Shows the value of primary variable.
PV %	1,1,2	Shows the primary variable value in percent of range.
PV AO	1,1,6	Shows the analog output value of the primary variable.
PV is	3,2,2,4	Select M1 DP, M2 AP, M6 Flow, or M7 Density.
PV LRV	2,1	Enter the lower range value.
PV Rerange	2	Path to setting PV LRV and PV URV.
PV URV	2,2	Enter the upper range value.
RTD Temp. (M5)	4,6	RTD temperature calibration procedure.
Sensor Temp. (M3)	3,5	Not used
Sensor Temp. (M3)	4,4	Sensor temperature calibration procedure.

Parameter	Fast-Key Path	Explanation
Software rev	3,1,1	Path to view the software revision level.
Software SubRevision	3,1,1	Path to view the software subrevision level.
SV	1,1,3	Shows the value of secondary variable.
SV is	3,2,2,5	Select M1 DP, M2 AP, M3 Sens Temp, M4 Elec Temp, M5 RTD, M6 Flow, or M7 Density.
Tag	3,1,2,1	Edit Tag information.
Temperature	3,7	Path to viewing or editing temperature parameters.
TV	1,1,4	Shows the value of tertiary variable.
TV is	3,2,2,6	Select M1 DP, M2 AP, M3 Sens Temp, M4 Elec Temp, M5 RTD, M6 Flow, or M7 Density.
View Parameters	3,1,1 3,2,1 3,3,1 3,4,1 3,7,1 3,8,1 3,9,1	Shows identification parameter data. Shows general parameter data. Shows differential pressure parameter data. Shows absolute pressure parameter data. Shows temperature parameter data. Shows flow parameter data Shows density parameter data.

Gauge pressure is equal to the atmospheric pressure minus the value entered in **ATM Ref**. It is not referenced to varying atmospheric pressure.

Calibration and Configuration Using the Optional Local Display

— NOTE —

You can configure many parameters using the local display. However, for more complete configuration capability, including flow rate configuration, use a PC-Based Configurator.

A local display, as shown in Figure 33, has two lines of information. The upper line is a 5-digit numeric display (4-digit when a minus sign is needed); the lower line is an 7-digit alphanumeric display. The display provides local indication of measurement information. The primary measurement is normally displayed. To view the secondary measurement, press the **Enter** button while in normal operating mode. To view the tertiary measurement, press the **Enter** button again. Press the **Next** or **Enter** button to return to the primary measurement. If power to the transmitter is interrupted, the display reverts to the primary display.

The display also provides a means for performing calibration and configuration, viewing the database, and testing the display via the 2-button keypad. You can access these operations by means of a multi-level menu system. Entry to the Mode Select menu is made (from normal operating mode) by pressing the **Next** button. You can exit this menu, restore your prior calibration or configuration, and return to the normal operating mode at any time by going to **Cancel** and pressing the **Enter** button.

— NOTE

During calibration or configuration, a single change could affect several parameters. For example, changing from linear to square root mode also changes the engineering units (EGU) to **% Flow** by default. For this reason, if an entry is entered in error, re-examine the entire database or use the **Cancel** feature to restore the transmitter to its starting configuration and begin again.

The following items can be selected from this menu: Calibration (**CALIB**); Configuration (**CONFIG**); Viewing the database (**VIEW DB**); and Testing the display (**TST DSP**). The top level structure diagram is shown in Figure 34.

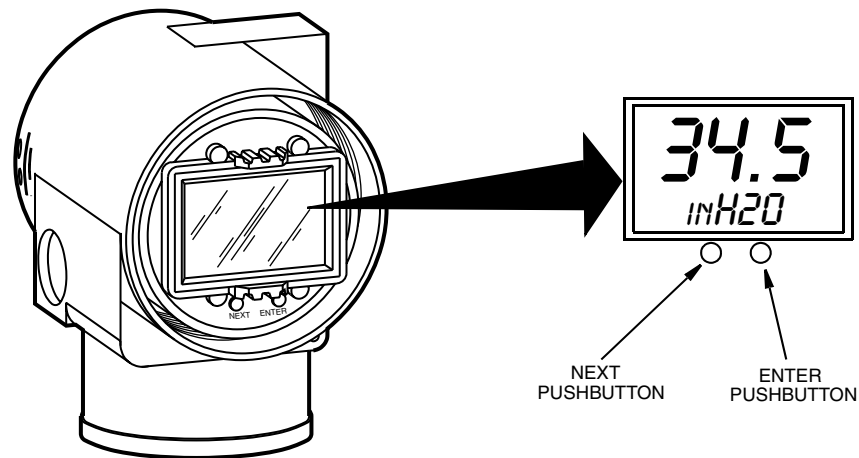

Figure 33. Local Display Module

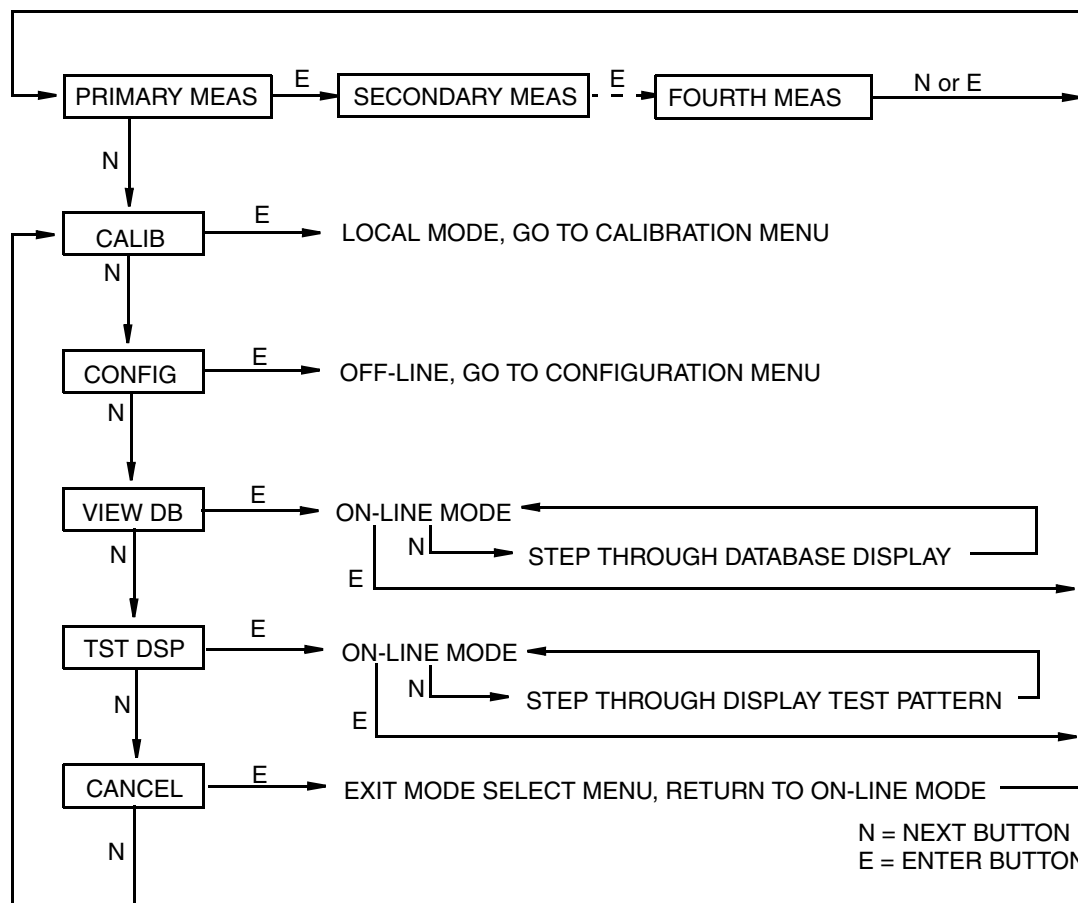

Figure 34. Top Level Structure Diagram

— **NOTE** —

In the Configuration menu and during adjustment of 4 and 20 mA in the Calibration menu, the milliampere output does not reflect live measurement values. Also, during Calibration and Configuration menu operations, the I/A Series system identifies all transmitter measurements as **BAD** because the transmitter is not in the on-line mode.

Entering Numerical Values

The general procedure for entering numerical values in Calibration and Configuration is as follows:

1. At the appropriate prompt, press the **Enter** button. The display shows the last (or default) value with the first digit flashing.
2. Use the **Next** button to select the desired first digit, then press the **Enter** button. Your selection is entered and the second digit flashes.
3. Repeat Step 2 until you have created your new value. If the number has less than five characters, use leading or trailing zeros for the remaining spaces. When you have configured the fifth space, the display prompts you to place the decimal point.

4. Move the decimal point with the **Next** button until it is where you want it and press the **Enter** button.

— **NOTE** —

1. The decimal point can not be placed directly after the first digit. For example, you can not enter a value as 1.2300; you must enter it as 01.230.
 2. The decimal position is identified by flashing except at the position after the fifth digit. At that position (representing a whole number), the decimal point is assumed.
-

5. The display advances to the next menu item.

Calibration

To access the Calibration mode (from the normal operating mode), press the **Next** button. The display reads **CALIB**, the first item on the menu. Acknowledge your choice of this selection by pressing the **Enter** button. The display shows the first item in the Calibration menu. You can then calibrate the items shown in Table 6.

— **NOTE** —

1. If calibration has been configured as password protected, you are asked to enter the password before you can proceed.
 2. If your transmitter is write protected, you cannot write your calibration to the electronics. To disable this feature, see “Setting the Write Protect Jumper” on page 26.
-

Table 6. Calibration Menu

Item	Description
CAL PWD	Enter password if required.
CAL DP	Calibrate differential pressure.
CAL AP	Calibrate absolute pressure.
CAL RTD	Calibrate the RTD.
CAL mA	Adjust nominal 4 mA and 20 mA output (D/A converter trim).
RERANGE	Set primary upper and lower range values.
CALDATE	Enter the calibration date.
CAL DP causes the following three submenus:	
CALDP 0	Calibrate at zero differential pressure.
CALDPLR	Calibrate with differential pressure at 0% of transmitter range. (LRV)
CALDPUR	Calibrate with differential pressure at 100% of transmitter range. (URV)
CAL AP causes the following three submenus:	
CALAPAT	Calibrate at atmospheric pressure.
CALAPLR	Calibrate with pressure at 0% of transmitter range. (LRV)
CALAPUR	Calibrate with pressure at 100% of transmitter range. (URV)

Table 6. Calibration Menu (Continued)

Item	Description
CAL RTD causes the following submenu:	
ADJTEMP	Edit current RTD temperature.
CAL mA causes the following two submenus:	
ADJ 4 mA	Adjust the 4 mA output.
ADJ20mA	Adjust the 20 mA output
RERANGE causes the following two submenus	
LRV	Set lower range value
URV	Set upper range value

— NOTE —

It is not recommended to use the **CAL mA** menu selections unless there is a plant requirement to make the upper and lower calibration values exactly match readings on certain plant calibration equipment and the **CALDPLR**, **CALDPUR**, **CALAPLR**, or **CALAPUR** operations result in a small but unacceptable difference between the transmitter mA output and the test equipment mA readout values.

Proceed to calibrate your transmitter by using the **Next** button to select your item and the **Enter** button to specify your selection per Figure 35. At any point in the calibration, you can **Cancel**, restore your prior calibration and return to the online mode or **Save** your new calibration. Calibration error messages are listed in Table 7.

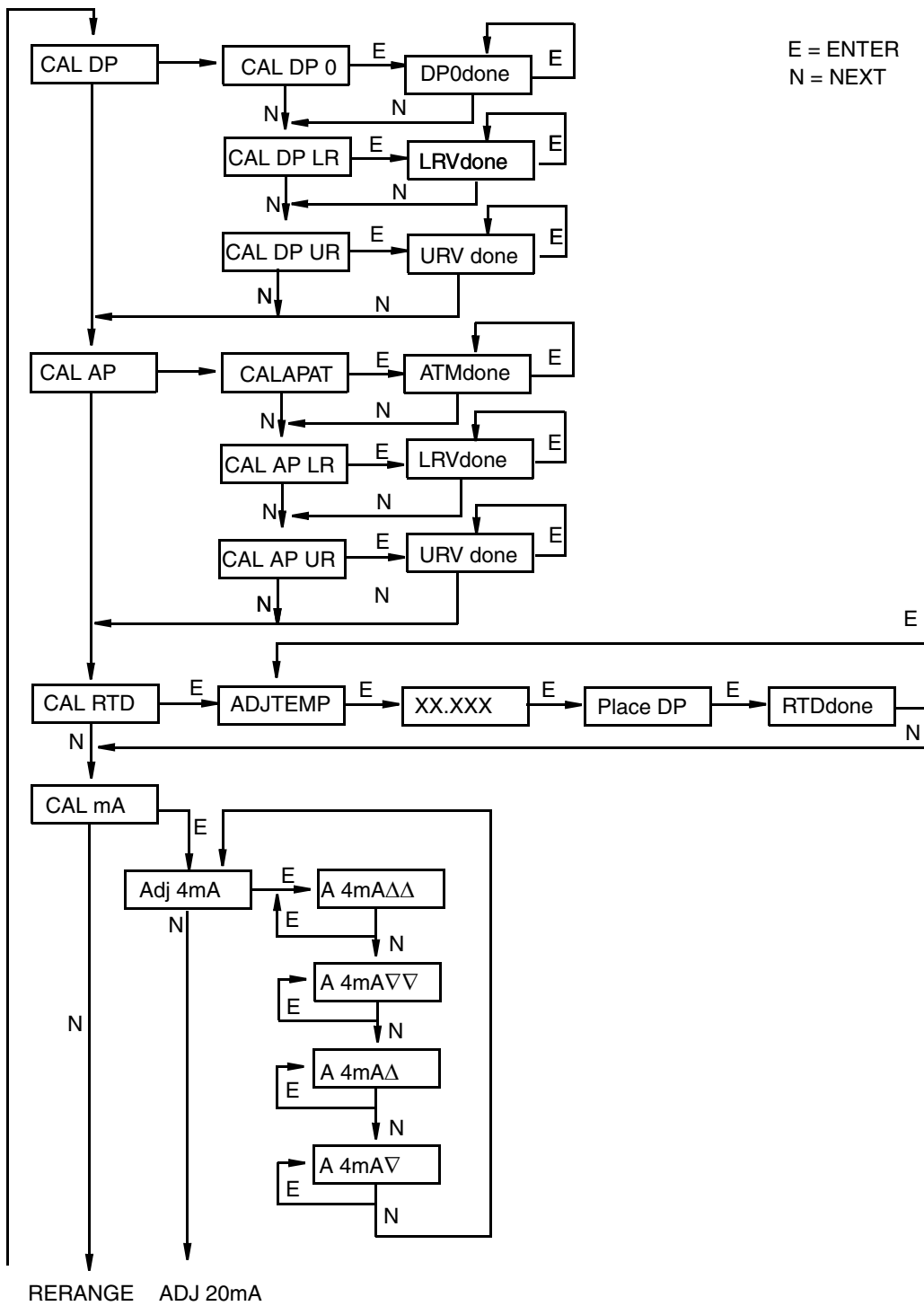
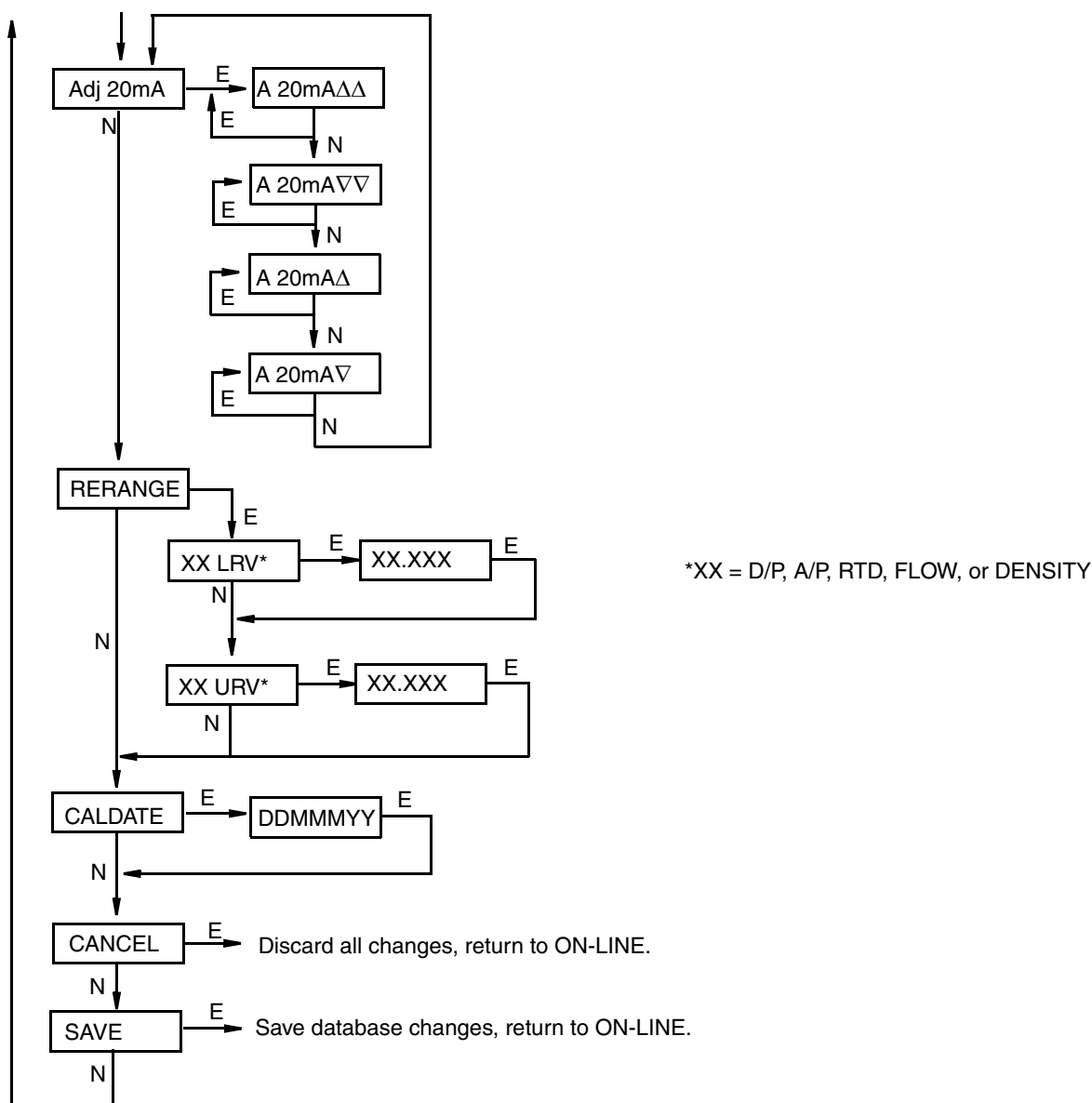

Figure 35. Calibration Structure Diagram



Calibration Structure Diagram (Continued)

Commentary on Figure 35

CAL DP

To calibrate the differential pressure measurement, press **Enter** at the display of **CAL DP**. Then, using the **Next** button, select **CAL DP 0**, **CAL DP LR**, or **CAL DP UR**.

To set or reset the zero point at zero pressure, apply zero differential pressure to the transmitter and, at display of **CAL DP 0**, press **Enter**. This can be done whether LRV is zero or not. Completion is indicated by the display **DP0done**. Press **Enter** to repeat or **Next** to move to **CAL DP LR**.

To set or reset 0% of range input, apply differential pressure to the transmitter equal to the Lower Range Value (LRV) in the transmitter data base and, at display of **CAL DP LR**, press **Enter**. Completion is indicated by the display **LRVdone**. Press **Enter** to repeat or **Next** to move to **CAL DP UR**.

To set or reset 100% of range input, apply differential pressure to the transmitter equal to the Upper Range Value (URV) in the transmitter database and, at display of **CAL DP UR**, press **Enter**. Completion is indicated by the display **URVdone**. Press **Enter** to repeat or **Next** to move to **CAL AP**.

CAL AP

To calibrate the pressure measurement, press **Enter** at the display of **CAL AP**. Then, using the **Next** button, select **CALAPAT**, **CAL DP LR**, or **CAL DP UR**.

To set or reset the zero point at atmospheric pressure, vent both the high and low side process connections of the transmitter to atmosphere and, at the display of **CALAPAT**, press **Enter**. Completion is indicated by the display **ATMdone**. Press **Enter** to repeat or **Next** to move to **CAL AP LR**.

To set or reset 0% of range input, apply pressure to both the high and low side process connections of the transmitter equal to the Lower Range Value (LRV) in the transmitter database and, at display of **CAL AP LR**, press **Enter**. Completion is indicated by the display **LRVdone**. Press **Enter** to repeat or **Next** to move to **CAL DP UR**.

To set or reset 100% of range input, apply pressure to both the high and low side process connections of the transmitter equal to the Upper Range Value (URV) in the transmitter database and, at display of **CAL DP UR**, press **Enter**. Completion is indicated by the display **URVdone**. Press **Enter** to repeat or **Next** to move to **CAL RTD**.

CAL RTD

To edit the current RTD temperature, at the display **CAL RTD**, press **Enter**. At the display **ADJTEMP**, press **Enter** again. Enter the temperature you desire and press **Enter**. Completion is indicated by the display **RTDdone**. Press **Enter** to repeat or **Next** to move to **CAL mA**.

CAL mA

If you configured your transmitter operating mode as 4 to 20 mA, you can adjust the 4 mA and 20 mA output by going to **CAL mA**, using the **Next** button and pressing **Enter**.

To increase the 4 mA output by a large (0.025 mA) step, press **Enter** at the display **A 4mA $\Delta\Delta$** . To decrease it by a large step, go to the display **A 4mA $\nabla\nabla$** by pressing the **Next** button and then **Enter**. To increase it by a small (0.001 mA) step, go to the display **A 4mA Δ** with the **Next** button and then press **Enter**. To decrease it by a small step, go to the display **A 4mA ∇** with the **Next** button and then press **Enter**.

ADJ20mA: Similar to **ADJ 4mA**.

RERANGE

You can adjust 100% and 0% range values of the primary measurement (if the primary measurement was specified as **PM=D/P**, **PM=A/P**, **PM=RTD**, **PM=FLOW**, or **PM=DENS** in **MX MAP**). To do this, go to **RERANGE** with the **Next** button and press **Enter**. You

can then adjust **XX URV** and/or **XX LRV** (where XX = D/P, A/P, RTD, FLOW, or DENS) in the following two submenus.

— **NOTE** —

1. If **DP MODE** is a type of square root, **RERANGE** (of **DP URV**) must be done in psi.
 2. **DP LRV** is bypassed if **DP MODE** is configured as a type of square root since **DP LRV** must be zero.
-

XX URV: To edit the upper range value, press **Enter** at the prompt **XX URV** (where XX = D/P, A/P, RTD, FLOW, or DENS). Use the procedure “Entering Numerical Values” on page 47 to edit this parameter.

XX LRV: Similar to **XX URV** immediately above.

CALDATE

This is not a required entry but can be used for recordkeeping or plant maintenance purposes. To edit the calibration date, go to **CALDATE** with the **Next** button and press **Enter**. You then can change the day, month, and year. The display shows the last date with the day flashing. Use the **Next** button to step through the menu of digits to select the desired day, then press **Enter**. Repeat this process for the month and year.

Configuration

You can access the Configuration mode by the same multi-level menu system that was used to enter Calibration mode. Entry to the Mode Select menu is made (from normal operating mode) by pressing the **Next** button. The display reads **CALIB**, the first item on the menu. Press the **Next** button again to get to the second item on the menu, **CONFIG**. Acknowledge your choice of this selection by pressing the **Enter** button. The display shows the first item in the Configuration menu. You can then configure items shown in Table 5. The standard factory default configuration is also given in this table.

The standard factory default configuration is not used if custom configuration option -C2 has been specified. Option -C2 is a full factory configuration of all parameters to the user's specifications.

— **NOTE** —

1. If configuration has been password protected, you are asked to enter the password before you can proceed.
 2. If your transmitter is write protected, you cannot write your configuration to the electronics. To disable this feature, see “Setting the Write Protect Jumper” on page 26.
-

Proceed to configure your transmitter by using the **Next** button to select your item and the **Enter** button to specify your selection per Figure 36. At any point in the configuration you can **Cancel** your changes and return to the on-line mode, or **Save** your changes.

Configuration error messages are listed in Table 8.

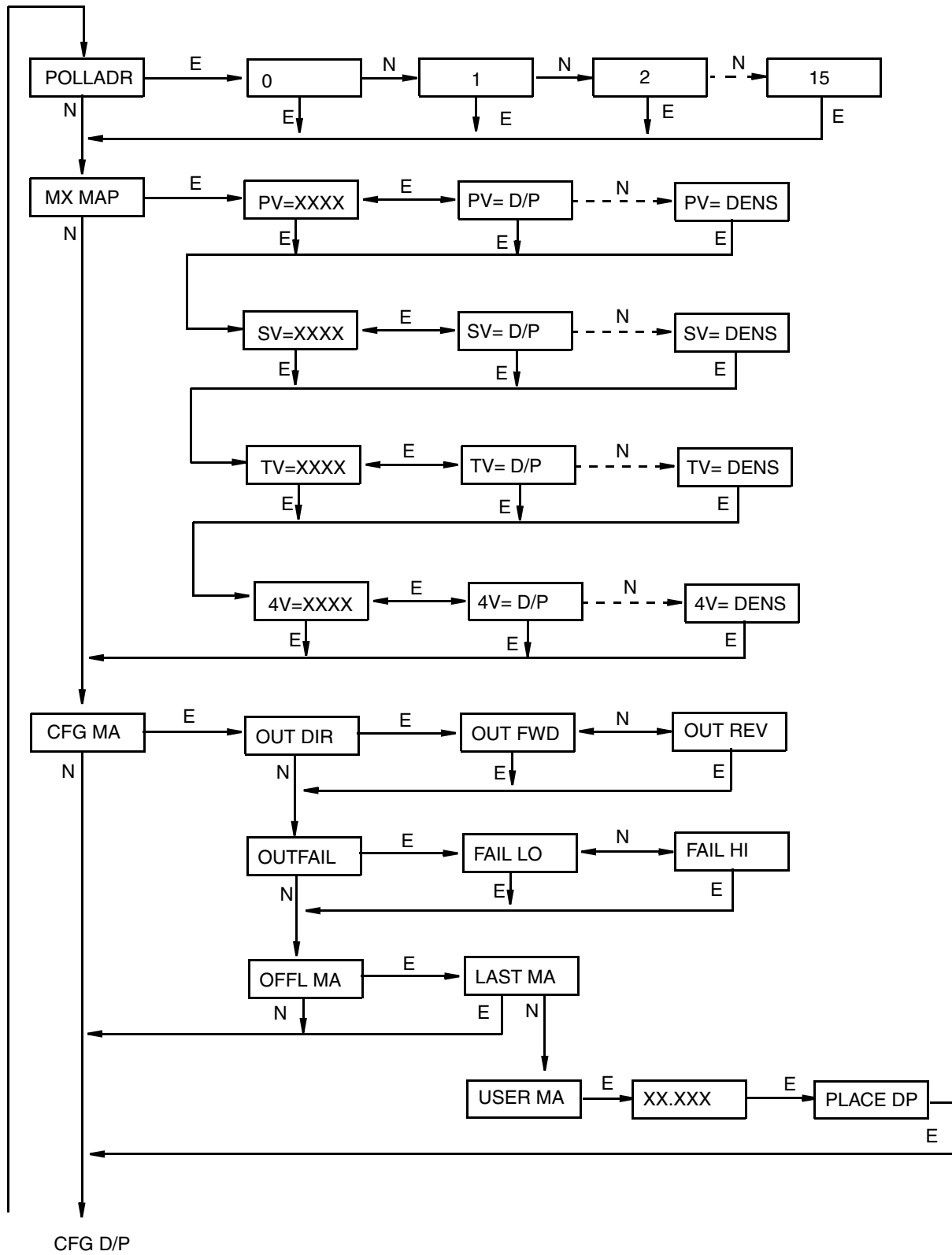
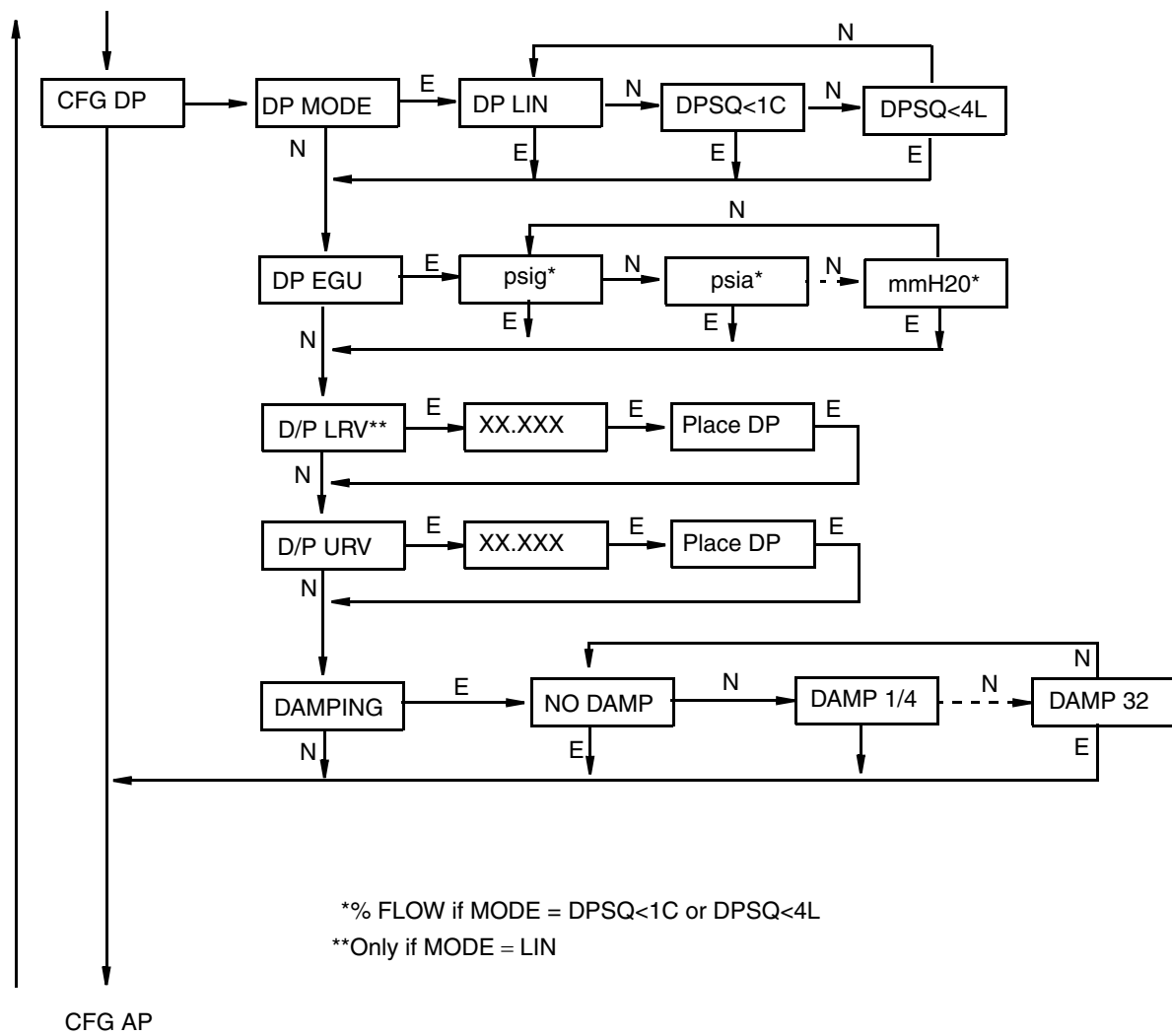
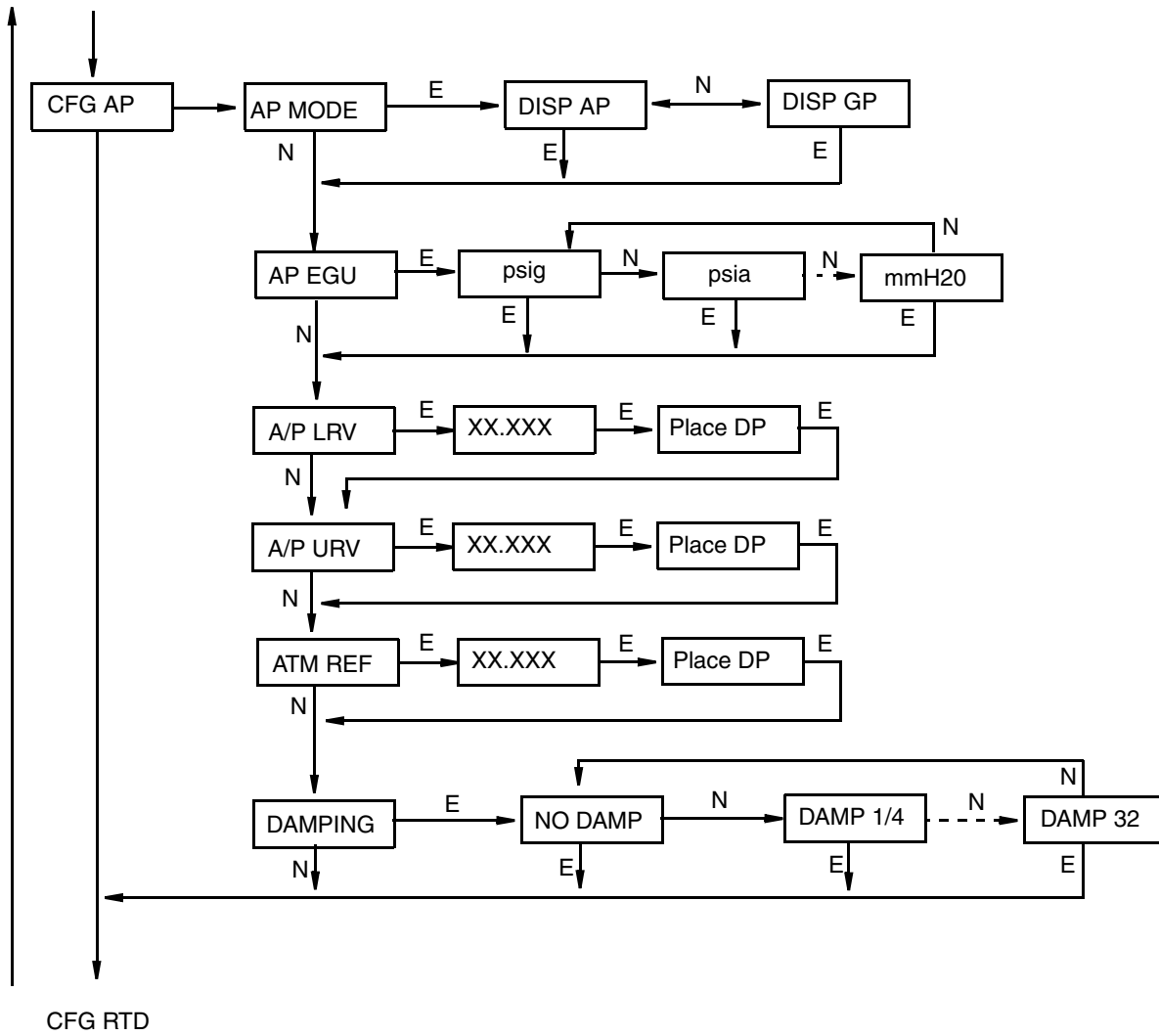

Figure 36. Configuration Structure Diagram



Configuration Structure Diagram (Continued)



Configuration Structure Diagram (Continued)

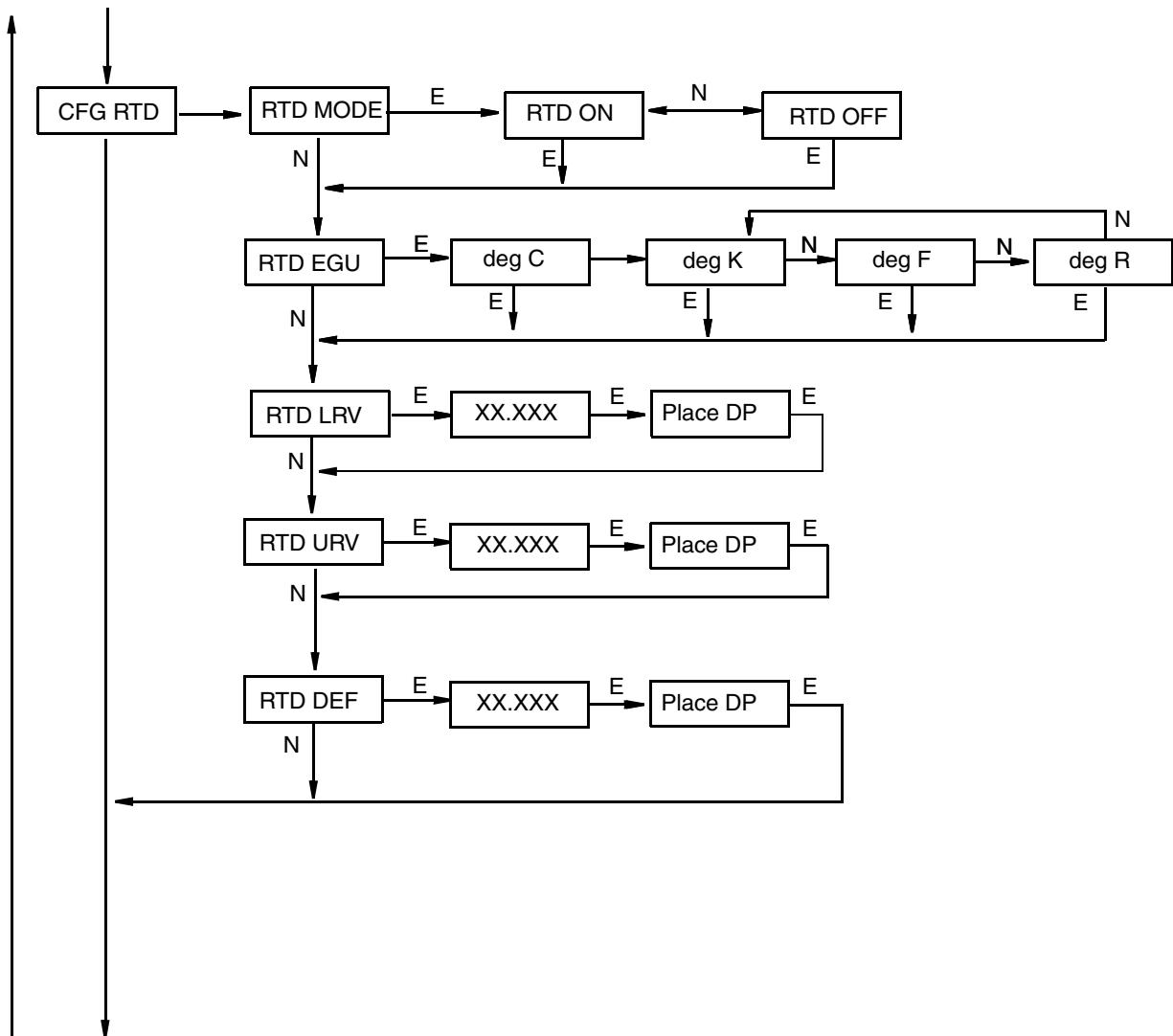

CGF FLOW (For IMV30)
CALDATE (For IMV25)

Configuration Structure Diagram (Continued)

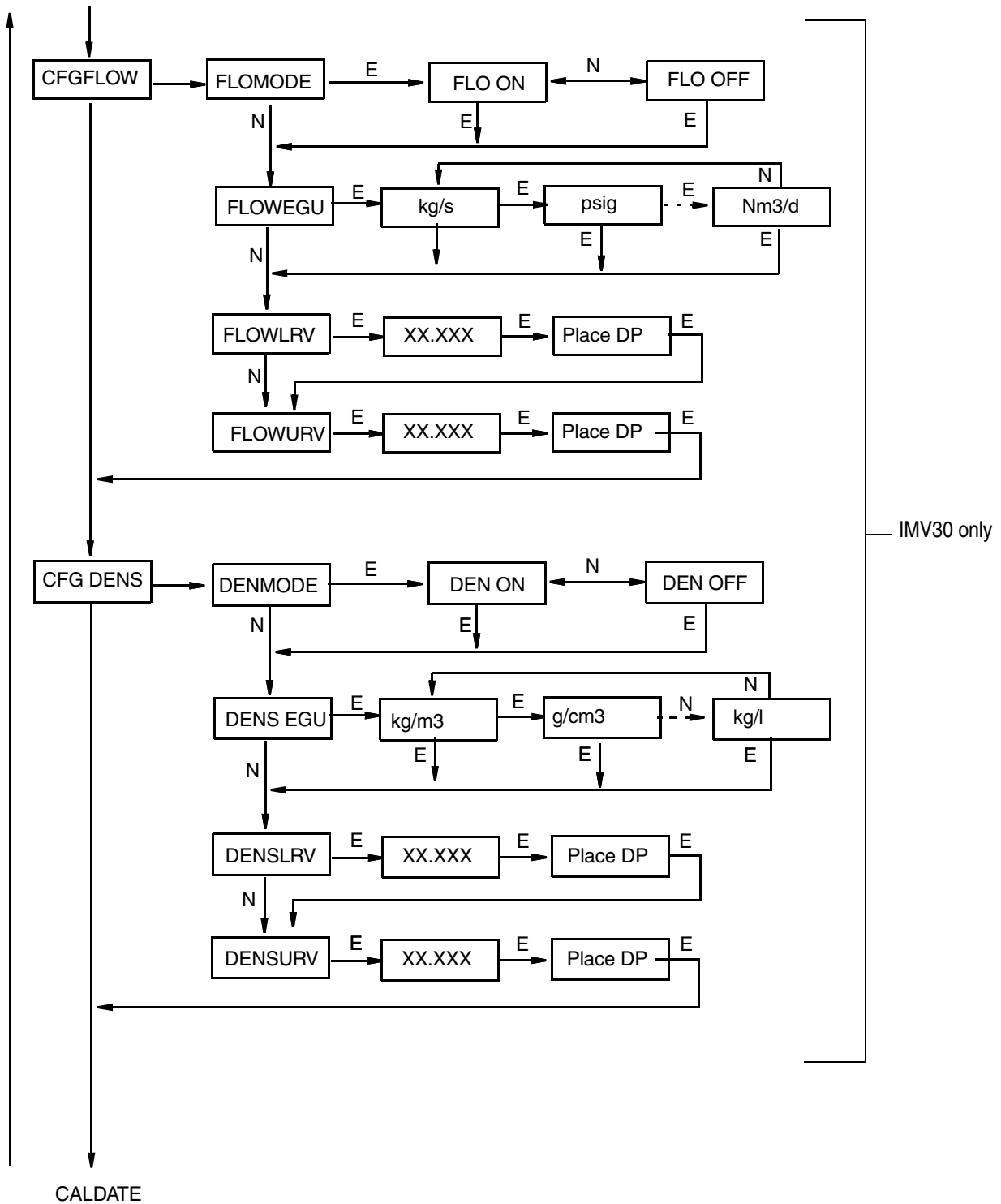

Configuration Structure Diagram (Continued)

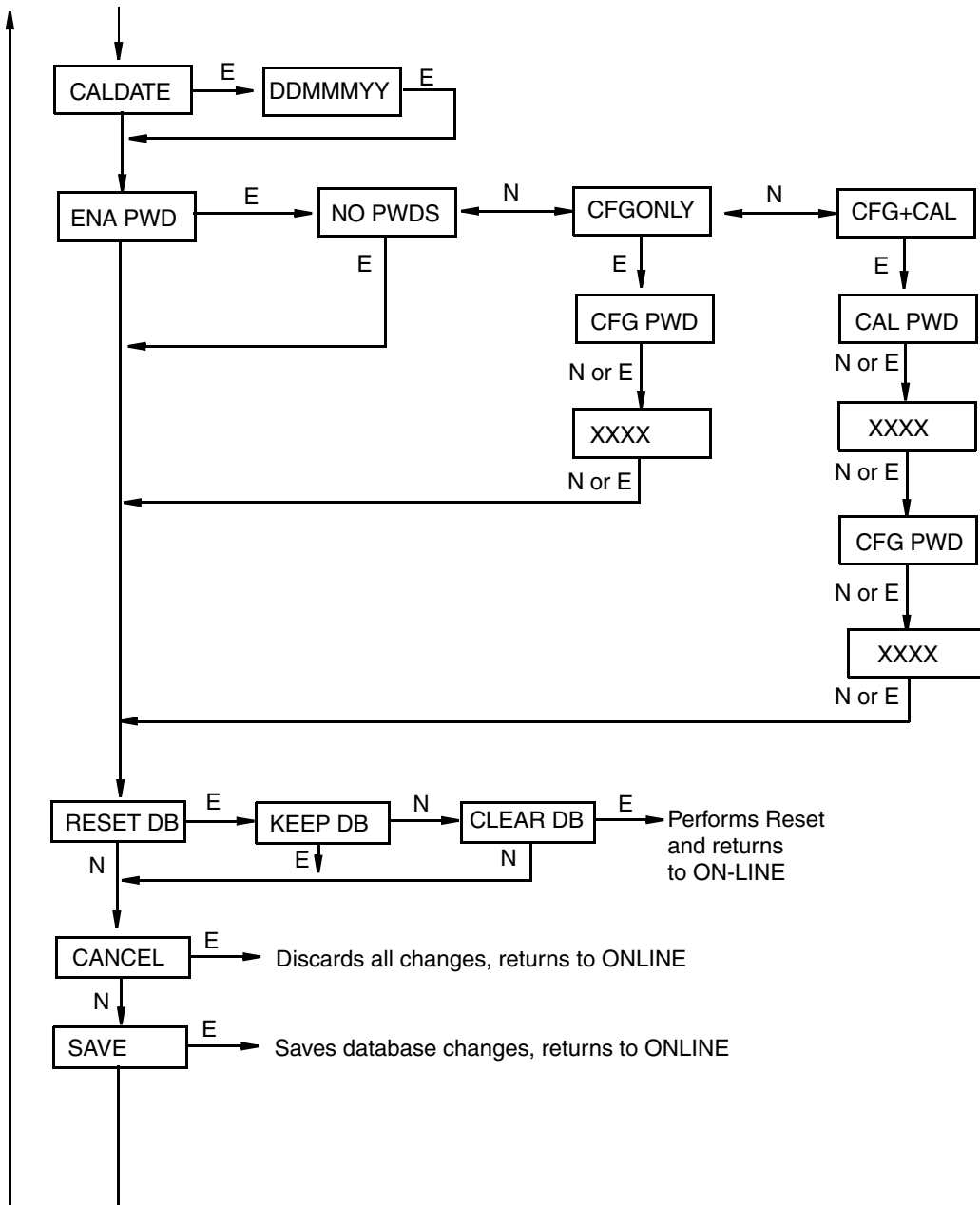

Configuration Structure Diagram (Continued)

Commentary on Figure 36

In general, use the **Next** button to select your item and the **Enter** button to specify your selection.

POLLADR:

To configure the transmitter poll address, press **Enter**. Use the **Next** button to select an address of **0** through **15** and press **Enter**.

MX MAP:

To configure the four measurements or calculations to be displayed on the local display and the I/A Series system, go to **MX MAP** with the **Next** button and press **Enter**. Use the **Next** button to select the primary measurement, **PV=xxxx**; the secondary measurement, **SV=xxxx**; the tertiary measurement, **TV=xxxx**; or the fourth measurement, **4V=xxxx** and press **Enter**. The current configuration blinks. Use the **Next** button to select the measurement or calculation for the display indicated and press **Enter**. You can configure each to display the differential pressure, **D/P**; the absolute pressure, **A/P**; the RTD measurement, **RTD**; the calculated flow, **FLOW** (IMV30 only); the calculated density, **DENS** (IMV30 only); the sensor temperature, **STMP**; or the electronics temperature, **ETMP**.

CFG MA:

To configure the mA output, go to **CFG MA** with the **Next** button and press **Enter**. The first parameter, **OUT DIR**, is displayed.

To configure the output direction, go to **OUT DIR** with the **Next** button and press **Enter**. Use the **Next** button to select **OUT FWD** (4 to 20 mA) or **OUT REV** (20 to 4 mA) and press **Enter**. This parameter is bypassed if **DP MODE** is configured as a type of square root.

The Outfail feature provides high or low output with certain malfunctions. To configure the fail mode output, go to **OUTFAIL** with the **Next** button and press **Enter**. Use the **Next** button to select **FAIL LO** (3.6 mA) or **FAIL HI** (22 mA) and press **Enter**.

The Offline mA feature enables you to set the output to a specified value or to the last value if the transmitter goes off-line. To configure the off-line output, go to **OFFL MA** with the **Next** button and press **Enter**. Use the **Next** button to select **LAST MA** or **USER MA** and press **Enter**. If you selected **USER MA**, press **Enter** again at the display of digits. Then use the **Next** button to step through the library of digits to select the desired first digit, then press **Enter**. Your selection is entered and the second character flashes. Repeat this procedure until you have entered the last digit. Then use the **Next** button to move the decimal point to its desired location and press **Enter**. The display advances to the next menu item.

CFG DP:

To configure the differential pressure measurement, go to **CFG DP** with the **Next** button and press **Enter**. The first parameter, **DP MODE**, is displayed.

To configure the differential pressure mode, press **Enter**. Then use the **Next** button to select **DP LIN** (linear), **DPSQ<1C** (square root with cutoff below 1% of calibrated pressure range), or **DPSQ<4L** (square root with linear below 4% of calibrated pressure range) and press **Enter**.

— NOTE —

You cannot configure this parameter as a type of square root if **OUT DIR** is configured as **OUT REV** or (in IMV30) if **FLOMODE** is configured as **FLO ON**.

To configure engineering units for your display and transmission, go to **DP EGU** and press **Enter**.

If you had previously selected linear mode, you are asked to specify one of the following units: **psi, inHg, FtH₂O, inH₂O, atm, bar, mbar, MPa, kPa, Pa, kg/cm², g/cm², cmHg, mmHg, torr, mH₂O, cmH₂O, or mmH₂O**. Then, set the **D/P URV** (upper range value) and **DP LRV** (lower range value).

If you had previously selected one of the square root modes, the engineering unit is **% Flow**. Set the **D/P URV** (upper range value).

To configure additional damping, go to **DAMPING** with the **Next** button and press **Enter**. Use the **NEXT** button to select **NO DAMP, DAMP 1/4, DAMP 1/2, DAMP 1, DAMP 2, DAMP 4, DAMP 8, DAMP 16, or DAMP 32** and press **Enter**.

CFG AP:

To configure the pressure measurement, go to **CFG AP** with the **Next** button and press **Enter**. The first parameter, **AP MODE**, is displayed.

To configure the absolute pressure mode, press **Enter**. Then use the **Next** button to select **DISP AP** (absolute pressure), **DISP GP** (gauge pressure), and press **Enter**.

To configure engineering units for your display and transmission, go to **AP EGU** and press **Enter**.

You are asked to specify one of the following labels: **psia, inHg, FtH₂O, inH₂O, atm, bar, mbar, MPa, kPa, Pa, kg/cm², g/cm², cmHg, mmHg, torr, mH₂O, cmH₂O, or mmH₂O**. Then, set the **A/P URV** (upper range value) and **DP LRV** (lower range value).

If **AP MODE** is configured **DISPGP**, you must configure the atmospheric reference. To do this, go to **ATM REF** and press **Enter**. Enter the desired value and press **Enter**.

CFG RTD:

To configure the RTD measurement, go to **CFG RTD** with the **Next** button and press **Enter**. The first parameter, **RTD MODE**, is displayed.

To configure the RTD mode, press **Enter**. Then use the **Next** button to select **RTD ON**, or **RTD OFF** and press **Enter**.

To configure engineering units for your display and transmission, go to **RTD EGU** and press **Enter**.

You are asked to specify one of the following labels: **deg C, deg K, deg F, or deg R**. Then, set the **RTD URV** (upper range value) and **RTD LRV** (lower range value).

To configure a default temperature value for flow and density calculations in the event of an RTD failure, go to **RTD DEF** with the **Next** button and Press **Enter**. Then set the default value.

CFG FLOW (IMV30 only):

To configure the flow calculation, go to **CFGFLOW** with the **Next** button and press **Enter**. The first parameter, **FLOMODE**, is displayed.

To configure the flow mode, press **Enter**. Then use the **Next** button to select **FLO ON** or **FLO OFF** and press **Enter**. **FLOMODE** cannot be configured **FLO ON** if **DP MODE** is a type if square root.

To configure engineering units for your display and transmission, go to **FLOWEGU** and press **Enter**.

You are asked to specify one of the following labels: **kg/s, kg/m, kg/h, kg/d, g/s, g/m, g/h, g/d, lb/s, lb/m, lb/h, lb/d, T/h, T/d, STon/h, STon/d, LTon/h, LTon/d, m3/s, m3/m, m3/h, m3/d, gal/s, gal/m, gal/h, gal/d, Mgal/h, Mgal/d, l/s, l/m, l/h, l/d, MI/h, MI/d, Ft3/s, Ft3/m, Ft3/h, Ft3/d, bbl3/s, bbl3/m, bbl3/h, bbl3/d, bbl4/s, bbl4/m, bbl4/h, bbl4/d, Sm3/s, Sm3/m, Sm3/h, Sm3/d, SF3/s, SF3/m, SF3/h, sF3/d, Sgal/s, Sgal/m, Sgal/h, Sgal/d, Sbl3/s, Sbl3/m, Sbl3/h, Sbl3/d, Sbl4/s, Sbl4/m, Sbl4/h, Sbl4/d, NI/s, NI/m, NI/h, NI/d, Nm3/s, Nm3/m, Nm3/h, or Nm3/d**. Lastly, set the **FLOWLRV** (lower range value) and **FLOWURV** (upper range value).

— **NOTE** —

Flow damping can be achieved by the **DAMPING** parameter under **CFG DP** and **CFG AP**.

CFG DENS (IMV30 only):

To configure the density measurement, go to **CFGDENS** with the **Next** button and press **Enter**. The first parameter, **DENMODE**, is displayed.

To configure the density mode, press **Enter**. Then use the **Next** button to select **DEN ON** or **DEN OFF** and press **Enter**.

To configure engineering units for your display and transmission (if in digital mode), go to **DENSEGU** and press **Enter**.

You are asked to specify one of the following labels: **kg/m3, g/cm3, oz/in3, lb/ft3, lb/yd3, LT/yd3, ST/yd3, lb/gal, or kg/l**. Then, set the **DENSLRV** (lower range value) and **DENSURV** (upper range value).

CALDATE:

This is not a required entry but can be used for recordkeeping or plant maintenance purposes. To edit the calibration date, go to **CALDATE** with the **Next** button and press **Enter**. You then can change the day, month, and year. The display shows the last date with the day flashing. Use the **Next** button to step through the library of digits to select the desired day, then press **Enter**. Repeat this process for the month and year.

ENA PWD:

To enable or disable the password feature, go to **ENA PWD** with the **Next** button and press **Enter**. Use the **Next** button to select **NO PWDS** (password feature disabled), **CFGONLY** (password required to configure only), or **CFG+CAL** (password required to both configure and calibrate) and press **Enter**.

If you selected **CFG ONLY**, the display changes to **CFG PWD**. Press either the **Next** or **Enter** button. Use the **Next** button to step through the library of characters to select the desired first character, then press **Enter**. Your selection is entered and the second character flashes. Repeat this procedure until you have created your password. If the password has less than six characters, use blanks for the remaining spaces. When you have configured the sixth space, the display advances to the next menu item.

If you selected **CFG+CAL**, the display changes to **CAL PWD**. To create the Calibration password, press either the **Next** or **Enter** button. Use the **Next** button to step through the library of characters to select the desired first character, then press **Enter**. Your selection is entered and the second character flashes. Repeat this procedure until you have created your password. If the password has less than six characters, use blanks for the remaining

spaces. When you have configured the sixth space, the display advances to **CFG PWD**. Use the same procedure to create the configuration password.

—  **CAUTION** —

Record your new password before saving changes to the database.

RESET DB:

If your transmitter database becomes corrupted and you receive an **INITERR** message upon startup, this function enables you to rewrite all calibration and configuration values with default values. Therefore, select **Keep DB** if your transmitter is functioning normally.

Viewing the Database

You can access the View Database mode by the same multi-level menu system that was used to enter Calibration and Configuration mode. Access to **View DB** is made (from normal operating mode) by pressing the **Next** button three times. Acknowledge your choice of this selection by pressing the **Enter** button. The first item on the view database menu is the firmware version, **FMW REV**. Pressing the **Next** button repeatedly steps you through the database. You can abort this procedure at any time by pressing the **Enter** button.

Testing the Display

You can access the Test Display mode by the same multi-level menu system that was used to enter Calibration, Configuration, and View Database mode. Entry to the Mode Select menu is made (from normal operating mode) by pressing the **Next** button. The display reads **CALIB**, the first item on the menu. Press the **Next** button three times to get to the fourth item on the menu, **TST DSP**. Acknowledge your choice of this selection by pressing the **Enter** button. The display shows the first test segment pattern. You can step through the five patterns by repeated use of the **Next** button. You can abort the test at any time by pressing the **Enter** button.

Error Messages

Table 7. Calibration Error Messages

Parameter	Condition Tested	Error Message	User Action
Password Protection	Password	BAD PWD	Bad password entered, use another.
Write Protection	Write protection enabled	REJECT	Displays when you attempt an action that is write protected.
CAL DP or CAL AP ZERO	Calculated offset too large	BADZERO	Check applied pressure and configured LRV.
	Completion of data collection	CALWAIT	Displayed while data is collected for calibration.
	Measurement Status Error	BADSTAT	If AP, check that calibrating pressure (or vent) is applied to both high and low pressure sides simultaneously.

Table 7. Calibration Error Messages (Continued)

Parameter	Condition Tested	Error Message	User Action
CAL RTD ADJTEMP	Calculated offset too large	BADOFST	Check RTD connections. Adjustment limited to 0.05% of range.
	Completion of data collection	CALWAIT	Displayed while data is collected for calibration.
	Measurement Status Error	BADSTAT	If AP, check that calibrating pressure (or vent) is applied to both high and low pressure sides simultaneously.
	RTD Mode	MEASOFF	Calibration attempt fails when RTD is configured Off.
CAL DP	DP Cal Point	CALnot0	User entered calibration point must be 0 for a 1-point calibration using an external device with DP in Square Root mode.
CAL DP or CAL AP SPAN	Calculated slope too large or too small	BADSPAN	Check applied pressure and configured LRV and URV.
	Completion of data collection	CALWAIT	Displayed while data is collected for calibration.
	Measurement Status Error	BADSTAT	If AP, check that calibrating pressure (or vent) is applied to both high and low pressure sides simultaneously.
RERANGE (entering URV)	M1URV > max pressure in EGU	URV>FMX	Entered pressure is greater than maximum rated pressure of transmitter. Check entry. Verify EGUs.
	M1URV < min pressure in EGU	URV<FMN	Entered pressure is less than minimum rated pressure of transmitter. Check entry. Verify EGUs.
	Entered URV value = LRV value	LRV=URV	Cannot set span to 0. Check entry. Check LRV. Verify EGU.
	Calculated turndown exceeds limit	BADTDWN	Span too small. Check entry. Check LRV. Verify EGU.
	Incorrect EGU conversion factor with M1 SqRt	BADECNV	Check EGU setting.
	M1EOFF not 0 with M1 SqRt	BADEOFF	Square root mode with nonzero M1EOFF is not valid. Contact Invensys.
	URV must be >LRV with M1 SqRt	URV<LRV	Square root mode with negative URV is not valid. Change M1 URV to valid positive value.
	LRV must be = 0 with M1 SqRt	LRVnot0	Square root mode with nonzero LRV is not valid. Change M1 LRV to 0.

Table 7. Calibration Error Messages (Continued)

Parameter	Condition Tested	Error Message	User Action
RERANGE (entering LRV)	M1LRV > max pressure in EGU	LRV>FMX	Entered pressure is greater than maximum rated pressure of transmitter. Check entry. Verify EGUs.
	M1LRV < min pressure in EGU	LRV<FMN	Entered pressure is less than minimum rated pressure of transmitter. Check entry. Verify EGUs.
	M1 URV = M1 LRV	LRV=URV	Cannot set span to 0. Check entry. Check URV. Verify EGU.
	Calculated turndown exceeds limit	BADTDWN	Span too small. Check entry. Check URV. Verify EGU.
	Incorrect EGU conversion factor with M1 SqRt	BADECNV	Verify EGU setting.
	M1EOFF not 0 with M1 SqRt	BADEOFF	Square root mode with nonzero M1EOFF is not valid. Contact Invensys.
	URV must be > LRV with M1 SqRt	URV<LRV	Square root mode with negative URV is not valid. Change M1 URV to valid positive value.
LRV must be = 0 with M1 SqRt	LRVnot0	Square root mode with nonzero LRV is not valid. Change M1 LRV to 0.	
A4MA	Adjustment exceeds maximum/minimum limit	HILIMIT LOLIMIT	Check loop resistance.
A20MA	Adjustment exceeds maximum/minimum limit	HILIMIT LOLIMIT	Check loop resistance.

Table 8. Configuration Error Messages

Parameter	Condition Tested	Error Message	User Action
Any Configuration Action	Calculation Delay	WAIT	Displayed temporarily during calculation of updated values that result from a configuration change. No user action is necessary.
Password Protection	Password	BAD PWD	Bad password entered, use another.
Write Protection	Write Protection Enabled	REJECT	Displays when user attempts an action that is write protected.
DP MODE (being changed to square root)	Incorrect EGU conversion factor with M1 SqRt	BADECNV	Verify EGU setting.
	M1EOFF not 0 with M1 SqRt	BADEOFF	Square root mode with nonzero M1EOFF is not valid. Contact Invensys.
	URV must be > LRV with M1 SqRt	URV<LRV	Square root mode with negative URV is not valid. Change M1 URV to valid positive value.
	LRV must be = 0 with M1 SqRt	LRVnot0	Square root mode with nonzero LRV is not valid. Change M1 LRV to 0.
	Flow mode must be off to put DP in SqRt	N/AFLOW	Change FLOMODE to OFF.
AP MODE (changing DISP GP or DISP AP)	Adjusted LRV is too large to display	LRV>DSP	EGU must be changed if you want to edit LRV value on display.
	Adjusted URV is too large to display	URV>DSP	EGU must be changed if you want to edit URV value on display.
FLOMODE (changing to ON)(IMV30 only)	DP must be in linear mode when flow calculations are active.	NAM1SQ	Change DP MODE to LINEAR.
ATM REF (in CFG AP)	ATM REF too high	ATM>20	ATM REF must be set below 20 psia.
	ATM REF too low	ATM<10	ATM REF must be set above 10 psia.

Table 8. Configuration Error Messages (Continued)

Parameter	Condition Tested	Error Message	User Action
RTD DEF	Default too high	DEF>FMX	Set default value lower
	Default too low	DEF>FMN	Set default value higher.
CFG any (entering URV)	M1URV > max pressure in EGU	URV>FMX	Entered pressure is greater than maximum rated pressure of transmitter. Check entry. Verify EGUs.
	M1URV < min pressure in EGU	URV<FMN	Entered pressure is less than minimum rated pressure of transmitter. Check entry. Verify EGUs.
	Entered URV value = LRV value	LRV=URV	Cannot set span to 0. Check entry. Check LRV. Verify EGU.
	Calculated turndown exceeds limit	BADTDWN	Span too small. Check entry. Check LRV. Verify EGU.
	Incorrect EGU conversion factor with M1 SqRt	BADECNV	Check EGU setting.
	M1EOFF not 0 with M1 SqRt	BADEOFF	Square root mode with nonzero M1EOFF is not valid. Contact Invensys.
	URV must be >LRV with M1 SqRt	URV<LRV	Square root mode with negative URV is not valid. Change M1 URV to valid positive value.
	LRV must be = 0 with M1 SqRt	LRVnot0	Square root mode with nonzero LRV is not valid. Change M1 LRV to 0.

Table 8. Configuration Error Messages (Continued)

Parameter	Condition Tested	Error Message	User Action
CFG any (entering LRV)	LRV > max pressure in EGU	LRV>FMX	Entered pressure is greater than maximum rated pressure of transmitter. Check entry. Verify EGUs.
	LRV < min pressure in EGU	LRV<FMN	Entered pressure is less than minimum rated pressure of transmitter. Check entry. Verify EGUs.
	URV = LRV	LRV=URV	Cannot set span to 0. Check entry. Check URV. Verify EGU.
	Calculated turndown exceeds limit	BADTDWN	Span too small. Check entry. Check URV. Verify EGU.
	Incorrect EGU conversion factor with M1 SqRt	BADECNV	Verify EGU setting.
	M1EOFF not 0 with M1 SqRt	BADEOFF	Square root mode with nonzero M1EOFF is not valid. Contact Invensys.
	URV must be > LRV with M1 SqRt	URV<LRV	Square root mode with negative URV is not valid. Change M1 URV to valid positive value.
	LRV must be = 0 with M1 SqRt	LRVnot0	Square root mode with nonzero LRV is not valid. Change M1 LRV to 0.
CFG any (changing EGU)	LRV in new EGU is too large to display	LRV>DSP	EGU must be changed if you want to edit LRV value on display.
	URV in new EGU is too large to display	URV>DSP	EGU must be changed if you want to edit URV value on display.
	Incorrect EGU conversion factor with M1 SqRt	BADECNV	Verify EGU setting.
	M1EOFF not 0 with M1 SqRt	BADEOFF	Square root mode with nonzero M1EOFF is not valid. Contact Invensys.

Table 9. Operation Error Messages

Parameter	Condition Tested	Error Message	User Action
Normal Operation	Write protection enabled	WR PROT	Displays periodically to notify user that unit is in Write Protect.
	Any non-on-line Condition	OFFLINE	Notifies user of a non-on-line condition.
	Raw input error	S# ERR	Check connections.
	Measurement error	M# ERR	Temperature and pressures must be within configured limits.
	Measurement is being overridden	OVERRIDE	Displays periodically to notify the user that an external PC or HART Communicator calibration or loop test operation is controlling one or more measurements. To return to normal operation, complete the external operation or cycle power to the transmitter.
Startup	Database OK or corrupted	INITERR	Perform RESET DB procedure.
	Bad MAU identification	UNK MAU	Contact our Global Client Support Center at 1-866-746-6477.
	RTD Mode configured Off	M5=OFF	Configure ON if desired.

4. Maintenance

—  **DANGER** —

For nonintrinsically safe installations, to prevent a potential explosion in a Division 1 hazardous area, de-energize transmitters before you remove threaded housing covers. Failure to comply with this warning could result in an explosion resulting in severe injury or death.

Fault Analysis

For error messages displayed on the PC-Based Configurator, refer to MI 020-496.

Infrequently, the optional display may display the message **FAULT** or **RESET**. Individual, temporary display of **FAULT** or **RESET** does not indicate a problem with the transmitter. If the cycle of **FAULT** followed by **RESET** persists, contact our Global Client Support Center at 1-866-746-6477.

In rare cases, the transmitter database can become corrupted and the transmitter does not go online when powered. This can potentially occur if power to the transmitter is interrupted during a **Save** operation. The optional display continually shows an alternating display of **INITERR** and **RESET**.

To restore the transmitter from this condition, use the **RESET DB** function shown on page 63. Because the **RESET DB** function sets a default database and overwrites all calibration and configuration data, the transmitter needs to be reconfigured and recalibrated.

Parts Replacement

Parts replacement is generally limited to the electronics module assembly, housing assembly, sensor assembly, terminal block assembly, cover O-rings, and optional display. For part numbers relating to the transmitter and its options, see PL 009-018.

Replacing the Electronics Module

To replace the electronics module assembly, refer to Figure 37 and proceed as follows:

1. Turn off the transmitter power source.
2. Remove the electronics compartment cover by rotating it counterclockwise. Screw in the cover lock if applicable.
3. Remove the digital display (if applicable) as follows: grasp the two tabs on the display and rotate it about 10° in a counterclockwise direction. Pull out the display and disconnect its cable.
4. Remove the electronics module from the housing by loosening the two captive screws that secure it to the housing. Then pull the module out of the housing far enough to gain access to the cable connectors on the rear of the module.

! CAUTION

The electronics module is “one assembly” at this point and is electrically and mechanically connected to topworks with a flexible ribbon signal cable, a 2-wire power cable, and in some cases, a cable for an external zero pushbutton. Do **not** exceed the slack available in these cables when removing the assembled module.

5. Unplug all cable connectors from the rear of the electronics module and place the module on a clean surface.
6. Predetermine connector orientation, then insert the cable connectors into the replacement module. Replace the module in the housing using care not to pinch the cables between the module and the housing. Tighten the two screws that secure the module to the housing.
7. Connect the cable from the digital display to the electronics module. Ensure that the O-ring is fully seated in the display housing. Then, holding the digital display by the tabs at the sides of the display, insert it into the housing. Secure the display to the housing by aligning the tabs on the sides of the assembly and rotating it about 10° in a clockwise direction.
8. Reinstall the cover onto the housing by rotating it clockwise to seat the O-ring into the housing and then continue to hand tighten until the cover contacts the housing metal-to-metal. If cover locks are present, lock the cover per the procedure described in “Cover Locks” on page 26.
9. Turn on transmitter power source.

The module replacement procedure is now complete.

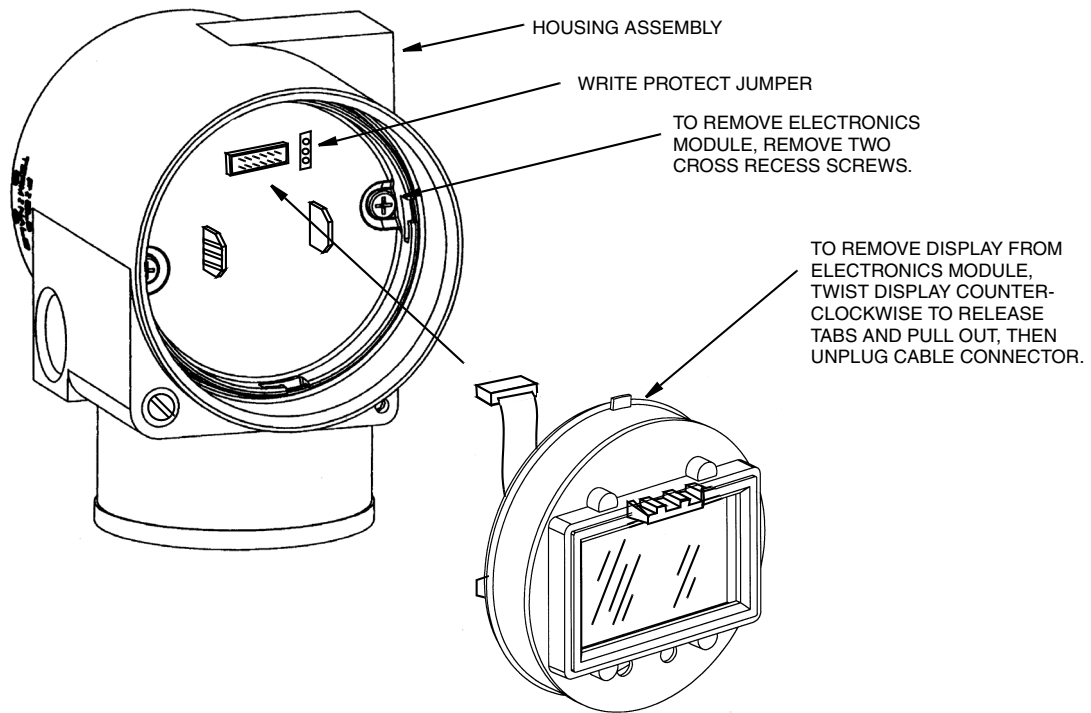

Figure 37. Replacing the Electronics Module Assembly and Display

Removing and Reinstalling a Housing Assembly

To remove and reinstall a housing assembly, refer to Figure 37 and proceed as follows:

1. Remove the electronics module per Steps 1 through 5 in the previous procedure.
2. If your housing has an anti-rotation screw, remove the red lacquer from the screw recess. Turn the screw three full turns counterclockwise.
3. If your housing has a retention clip, remove the red lacquer from the screw recess. Remove the screw completely, and slide the clip off the housing. Save the clip and screw for future use,
4. Remove the housing by rotating it counterclockwise (when viewed from the top). Use caution to avoid damaging the sensor cable.
5. Inspect the sensor O-ring for damage. If the O-ring is damaged, replace it with the appropriate O-ring. (See parts list for your transmitter). Lubricate the O-ring with silicone lubricant (Foxboro Part Number 0048130 or equivalent). Verify that the O-ring is situated in the groove of the neck.

! WARNING

Failure to reuse or install the proper O-ring for a CSA labeled product violates ANSI / ISA 12.27.01.

6. Feed the sensor cable through the housing neck into the electronics compartment.
7. Screw the housing onto the sensor neck until it bottoms. Do not over tighten. Be careful not to damage the sensor cable or dislodge the neck O-ring.
8. If your housing has an anti-rotation screw, engage the screw until it touches the sensor neck and back it off 1/8th turn. It is important that the screw is not touching the sensor. Fill the screw recess with red lacquer (Foxboro Part Number X0180GS or equivalent). The housing can then be rotated up to one full turn counterclockwise for optimum access.
9. If your housing has a retention clip, insert the clip over the boss in the housing neck so that the hole in the clip is aligned with the hole in the boss. Install the screw but do not tighten. Rotate the housing up to one full turn counterclockwise for optimum access. Tighten the retention clip screw and fill the screw recess with red lacquer (Foxboro Part Number X0180GS or equivalent). The housing can still be rotated for optimum access.
10. Reinstall the electronics module per Steps 6 through 9 in the previous procedure.

Replacing the Sensor Assembly

To replace the sensor assembly, refer to Figure 38 and proceed as follows:

1. Remove the electronics module as described above.
2. Remove the housing as described above.
3. Remove the process covers from sensor by removing two hex head bolts.
4. Replace gaskets in process covers.

5. Install process covers and housing on new sensor. Torque cover bolts to 100 N·m (75 lb·ft) in several even increments. Torque values are 68 N·m (50 lb·ft) when 316 ss bolts are specified; 75 N·m (55 lb·ft) when B7M bolts are specified.
6. Reinstall electronics module.
7. Pressure test the sensor and process cover assembly by applying a hydrostatic pressure of 150% of the maximum static and overrange pressure rating (see page 3) to both sides of the process cover/sensor assembly simultaneously through the process connections. Hold pressure for one minute. There should be no leakage of the test fluid through the gaskets. If leakage occurs, retighten the cover bolts per Step 5 (or replace the gaskets) and retest.

! CAUTION
Perform hydrostatic test with a liquid and follow proper hydrostatic test procedures.

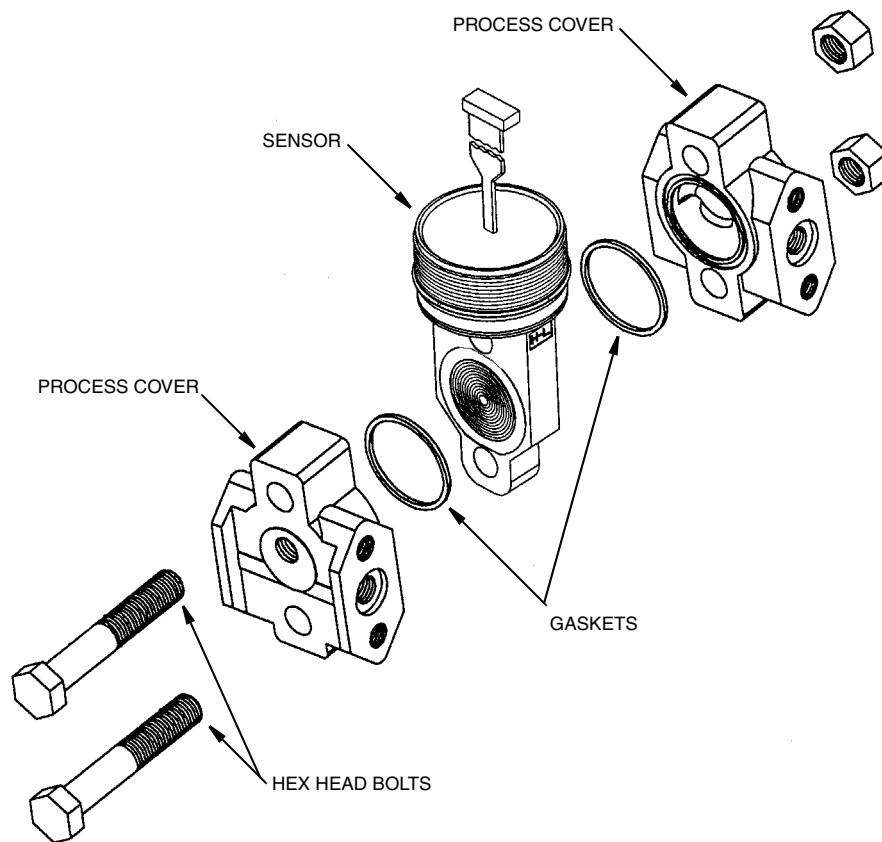

Figure 38. Replacing the Sensor Assembly

Replacing the Terminal Block Assembly

1. Turn off the transmitter power source.
2. Remove the Field Terminals compartment cover by rotating it counterclockwise. Screw in the cover lock if applicable.
3. Remove the four socket head screws securing the terminal block.
4. Disconnect the loop wiring and RTD connectors from the terminal block.
5. Remove the terminal block and the gasket under it.
6. Reconnect the loop wiring and RTD connectors to the new terminal block.
7. Install the new terminal block and new gasket and reinstall the four screws to 0.67 N·m (6 in·lb) in several even increments.
8. Reinstall the cover onto the housing by rotating it clockwise to seat the O-ring into the housing and then continue to hand tighten until the cover contacts the housing metal-to-metal. If cover locks are present, lock the cover per the procedure described in “Cover Locks” on page 26.
9. Turn on transmitter power source.

Adding the Optional Display

To add the optional display, refer to Figure 37 and proceed as follows:

1. Turn off the transmitter power source.
2. Remove the electronics compartment cover by rotating it counterclockwise. Screw in the cover lock if applicable.
3. Plug the display into the receptacle at the top of the electronics assembly.
4. Ensure that the O-ring is seated in its groove in the display housing. Then insert the display into the electronics compartment by grasping the two tabs on the display and rotating it about 10° in a clockwise direction.
5. Install the new cover (with a window) onto the housing by rotating it clockwise until the O-ring contacts the housing; then continue to hand tighten until the cover contacts the housing metal-to-metal. If cover locks are present, lock the cover per the procedure described in “Cover Locks” on page 26.
6. Turn on the transmitter power source.

Rotating Process Covers for Venting

As received, the IDP10 Transmitter provides sensor cavity draining without the need for side drain connections, regardless of whether the transmitter is mounted vertically or horizontally. Sensor cavity venting is provided by mounting horizontally or with the optional vent screw (-V). However, if you did not specify this option, you can still achieve venting (instead of draining) with vertical mounting by rotating the process covers. See Figure 39.

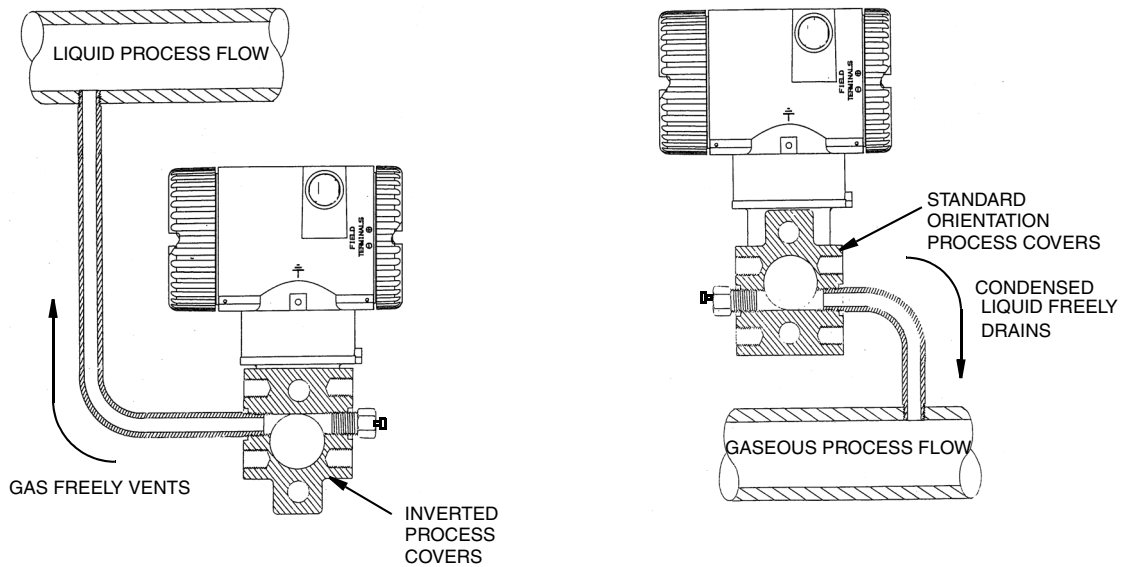

Figure 39. Sensor Cavity Venting and Draining

To rotate the process covers, refer to Figure 38 and proceed as follows:

1. Remove the process covers from the sensor by removing two hex head bolts.
2. Replace the gaskets in the process covers.
3. Rotate the process covers so that the longer tab is at the bottom.
4. Reinstall the process covers and bolts. Torque the cover bolts to 100 N·m (75 lb·ft) in several even increments. Torque values are 68 N·m (50 lb·ft) when 316 ss bolts are specified; 75 N·m (55 lb·ft) when B7M bolts are specified.
5. Pressure test the sensor and process cover assembly by applying a hydrostatic pressure of 150% of the maximum static and overrange pressure (see page 3) to both sides of the process cover/sensor assembly simultaneously through the process connections. Hold pressure for one minute. There should be no leakage of the test fluid through the gaskets. If leakage occurs, retighten the cover bolts per Step 4 or replace the gaskets and retest.

! CAUTION

Perform hydrostatic test with a liquid and follow proper hydrostatic test procedures.

Index

C

Calibration and Configuration 35
Calibration Setup 35
Configurable Parameters 37
Cover Locks 26

D

Display 25
Display, Adding 76
Draining and Venting 20

E

Electronics Module, Replacing 71
Error Messages 63

F

Fault Analysis 71
Field Terminals 26
Filling System with Seal Liquid 24
Firmware Version 1

G

General Description 1
Ground Connections 28

H

HART Communicator, Calibration and Configuration Using a 40
Housing Assembly, Removing and Reinstalling 74

I

Identification 2
Installation 13

L

Local Display, Calibration and Configuration Using the Optional 45

M

Maintenance 71

Mounting 13

P

Parts Replacement 71
 PC-Based Configurator, Calibration and Configuration Using a 40
 Pipe- or Surface-Mounted Transmitter 15
 Piping 21
 Positioning Housing 25
 Product Safety Specifications 9
 Putting Transmitter into Operation 33

R

Reference Documents 1

S

Sensor Assembly, Replacing 74
 Specifications 3

T

Taking Transmitter Out of Operation 34
 Terminal Block Assembly, Replacing 76
 Testing the Display 63

V

Venting and Draining 20
 Venting, Rotating Process Covers for 76
 Viewing the Database 63

W

Wiring 26
 Write Protection 26

ISSUE DATES

JUL 2002
 NOV 2004
 JUN 2005
 FEB 2006
 FEB 2008
 MAY 2010

Vertical lines to the right of text or illustrations indicate areas changed at last issue date.

Invensys Operations Management
 5601 Granite Parkway Suite 1000
 Plano, TX 75024
 United States of America
<http://www.iom.invensys.com>

Global Customer Support
 Inside U.S.: 1-866-746-6477
 Outside U.S.: 1-508-549-2424 or contact
 your local Invensys representative.
 Email: support@invensys.com
 Website: <http://support.ips.invensys.com>

Invensys, Foxboro, and I/A Series are trademarks of
 Invensys plc, its subsidiaries, and affiliates.
 All other brand names may be trademarks of their
 respective owners.

Copyright 2002-2010 Invensys Systems, Inc.
 All rights reserved