

**PSSST Sanitary Tank Spud
Direct Mounted Pressure Seals**
For use with I/A Series® Pressure Transmitters
Models IDP10 and IGP20

(For transmitter dimensions, refer to the transmitter Dimensional Print.)

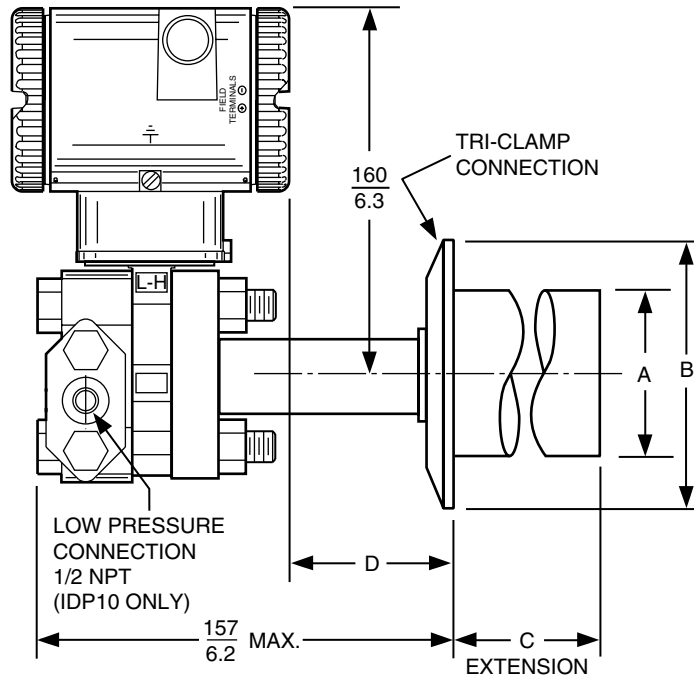

PRESSURE SEAL DIMENSIONS

Tank Spud Size	Extension (nominal)	Dimensions			
		A	B	C	D
2-in (Mini Spud)	1 1/2 in	54.1 mm (2.13 in)	77.5 mm (3.05 in)	38.1 mm (1.50 in)	30 mm (1.2 in)
	6 in			152.4 mm (6.00 in)	
	9 in			228.6 mm (9.00 in)	
4-in (Std Spud)	2 in	100.1 mm (3.94 in)	132.6 mm (5.22 in)	53.3 mm (2.10 in)	56 mm (2.2 in)
	6 in			154.9 mm (6.10 in)	

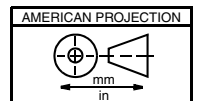

For dimensional information specific to your sales order, refer to Certified Dimensional Prints (CDPs) which can be ordered from your Foxboro Sales Office or authorized factory representative.

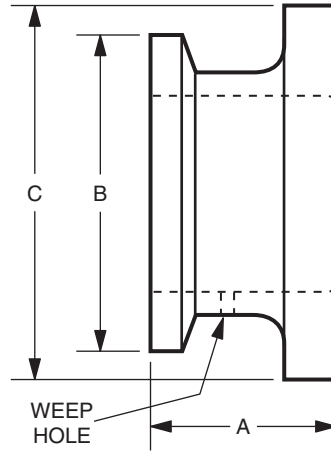

Tank Spud Size	Tank Spud Description	Dimensions		
		A	B	C
2-in Mini Spud	1 1/2 inch Ext.	38.1 mm (1.50 in)	77.5 mm (3.05 in)	94.7 mm (3.73 in)
	6 inch Ext.	152.4 mm (6.00 in)	77.5 mm (3.05 in)	94.7 mm (3.73 in)
	9 inch Ext.	228.6 mm (9.00 in)	77.5 mm (3.05 in)	94.7 mm (3.73 in)
4-in Standard Spud	2 inch Ext.	53.3 mm (2.10 in)	132.6 mm (5.22 in)	151.9 mm (5.98 in)
	6 inch Ext.	154.9 mm (6.10 in)	132.6 mm (5.22 in)	151.9 mm (5.98 in)

33 Commercial Street
 Foxboro, MA 02035-2099
 United States of America
 www.foxboro.com
 Inside U.S.: 1-866-746-6477
 Outside U.S.: 1-508-549-2424
 or contact your local Foxboro
 representative.
 Facsimile: 1-508-549-4999

Invensys, Foxboro, and I/A Series are trademarks of Invensys plc, its subsidiaries, and affiliates.
 All other brand names may be trademarks of their respective owners.

Copyright 2003-2005 Invensys Systems, Inc.
 All rights reserved

MB 190

Printed in U.S.A

0705