

Pressure Seals for Use with I/A Series® Pressure Transmitters



The Foxboro® brand Pressure Seals are available from Invensys. They are used with the I/A Series Pressure Transmitters when it is necessary to keep the transmitter isolated from the process. A sealed system is used for a process fluid that may be corrosive, viscous, subject to temperature extremes, toxic, sanitary, or tend to collect and solidify.

FEATURES

- ▶ Selection of flanged level or flanged remote mount seals with flush or extended diaphragms. Also recessed diaphragm seals for direct or remote mount with flanged, in-line saddle weld or threaded process connections.
- ▶ Sanitary direct connect or remote mount diaphragm seals offered that meet FDA requirements. Seals offered with either a 32 Ra or a 15 Ra surface finish. The 32 Ra finish is applicable to most sanitary industry applications. The 15 Ra finish is ideally applicable to the Biopharmaceutical and Pharmaceutical industries. Tri-Clamp type connectors are used to secure the process connections.
- ▶ FDA approved Neobee fill fluid for sanitary applications.
- ▶ Flanged seals with ANSI or BS/DIN carbon or stainless steel flanges in many sizes and ratings.
- ▶ Seals with threaded process connections from ¼ to 2 NPT.
- ▶ In-line, saddle weld seals for 3- or 4-inch (and larger) process pipes.
- ▶ Numerous seal sizes available depending on the seal model selected.
- ▶ Diaphragms available flush with the flange face; and also available with extensions for flush mounting with inside surface of the tank.
- ▶ Capillary lengths from 1.5 to 15 m (5 to 50 ft) for remote mount applications. Capillary is 300 Series with flexible armor, and is available with or without a protective coating.

- ▶ Carbon steel, 316L SS, highly corrosion-resistant nickel alloy (equivalent to Hastelloy C[®]-276⁽¹⁾), Titanium, Monel, Nickel, and Inconel are offered as diaphragm materials consistent with the seal configuration selected.
- ▶ Fill fluids accommodate process temperatures up to 204°C (400°F) for sanitary and direct connect seals, and up to 304°C (580°F) for remote capillary connected seals. See Table 1 for specific gravities.

GENERAL PRESSURE SEAL SPECIFICATIONS

INTRODUCTION

Sealed measurement systems, comprising the transmitter sensing element, pressure seal, and connecting tubing (as applicable), are evacuated and filled with an appropriate fill fluid that transmit pressure changes. A pressure seal assembly can be for flanged level applications, direct connected to the transmitter, or remote mounted using an interconnecting capillary.

SELECTION OF PROCESS CONNECTIONS WITH DIRECT CONNECT OR REMOTE MOUNT SEALS

Direct connect or remote mount seals are offered with flanged, threaded, or in-line welded process connections. See Table 2 for seal models.

SANITARY SEALS

Sanitary seals are used in food and dairy product applications and meet FDA and United States Public Health Service, Dairy Industry Committee requirements. A seal surface finish of 32 Ra is offered for use in most sanitary industry applications. The seal surface can also be polished to 15 microinches for use in industries such as Biopharmaceutical and Pharmaceutical. Tri-Clamp type connectors are used to secure the sanitary end connection to the process or tank spud.

FLUSH DIAPHRAGM SEALS

These seals are offered with flanged and sanitary process connections. They minimize pockets or cavities where process liquid can collect, and are available in many corrosion resistant materials, including 316L SS, nickel alloy (equivalent to Hastelloy C[®]-276), and PSFFD.

RECESSED DIAPHRAGM SEALS

Recessed diaphragm seal assemblies are available in flanged, threaded, and in-line weld configurations. Numerous process-wetted metal selections are offered. With the flanged configuration, nonmetallic PVC and glass-filled Teflon are also offered for users who are not concerned with a pressure derating to 1030 kPa (150 psi).

EXTENDED DIAPHRAGMS

Flush seals with flanged process connections can be provided with extended diaphragms. This allows the sensing diaphragm to extend through the mounting nozzle and be flush with the inside surface of the tank, eliminating pockets or cavities. Various diaphragm materials and extension lengths up to 230 mm (9 in) are offered, depending on the seal model selected.

REMOTE MOUNT SEAL ORIENTATION TO MATCH APPLICATION REQUIREMENTS

- ▶ Dual Seal Version - Balanced
- ▶ Single Seal - High Pressure Side
- ▶ Single Seal - Low Pressure Side

(1) Hastelloy is a registered trademark of Haynes International, Inc.

GENERAL PRESSURE SEAL SPECIFICATIONS

REDUCED TEMPERATURE EFFECT

Optimum temperature performance is achieved when both the seal diaphragm stiffness and system fill fluid volume are at their least (see Optimized Capillary Selection paragraph below). Larger diaphragms have lower stiffness and are therefore less affected by temperature. With small pressure measurement spans, it is best to select the largest diaphragm size that can be reasonably used.

OPTIMIZED CAPILLARY SELECTION

With remote seal(s), capillary internal diameter must be small to reduce fill volume, but large enough for adequate speed of response. Capillaries for remote seal(s) are available in various lengths and several internal diameters. The selections allow optimizing temperature performance while maintaining adequate speed of response. Capillaries are offered with 300 Series stainless steel armor, and also coated armor, for protection against damage.

CHOICE OF FILL FLUIDS TO MEET PROCESS REQUIREMENTS

When selecting a seal fill fluid, the first considerations are temperature capability of the fluid and compatibility with the process in the event of diaphragm failure. Several silicone fluids are offered that cover various temperature ranges. For processes with strong oxidizing agents such as chlorine or oxygen, Inert fill should be selected. Inert fill is also suitable for extreme cold temperatures. For sanitary applications, Neobee M20 fill is offered.

PRESSURE SEAL ORDERING INSTRUCTIONS

These pressure seals are used with the I/A Series Pressure Transmitters. Although seals are shipped assembled to the transmitter, they must be ordered separately. Each transmitter Model Code has a Structure Code selection, which defines whether a transmitter is to be ordered without seals, with remote mount seals, or with direct connect seals. Table 3 identifies which pressure seals can be used with which transmitter. Tables 7 and 8 at the end of this document identify the applicable transmitter PSS.

After making the required Structure Code selection in the transmitter Model Code, the user then selects the applicable seal Model Number(s) from this document.

Therefore, a transmitter with seals comprises both a Transmitter Model Number and Seal Model Number(s). Ordering instruction examples are shown further in this document in the Model Code section for each seal model.

HIGH PERFORMANCE

Refer to the Performance Data section at the end of this document for representative temperature and response characteristics with different diaphragms, fill fluids, and capillary dimensions.

FILL FLUID PRESSURE-TEMPERATURE LIMITS AND SPECIFIC GRAVITIES

Figure shows the relationship between Minimum Allowable Absolute Pressure versus Process Temperature for the various fill fluids used with the pressure seals. Table 1 lists the specific gravities of the various pressure seal fill fluids used.

Table 1. Fill Fluid Specific Gravities

Fill Fluid	Specific Gravity
DC 200 Silicone, 10 cSt	0.93 @ 25°C (77°F)
FC77 Inert	1.77 @ 25°C (77°F)
DC 200 Silicone, 3 cSt	0.89 @ 25°C (77°F)
DC 704 Silicone	1.07 @ 25°C (77°F)
Neobee M20	0.92 @ 25°C (77°F)
Halocarbon 4.2	1.85 @ 25°C (77°F)
Syltherm XLT	0.85 @ 25°C (77°F)

Figure 1. Minimum Allowable Pressure vs. Process Temperature - Fill Fluids

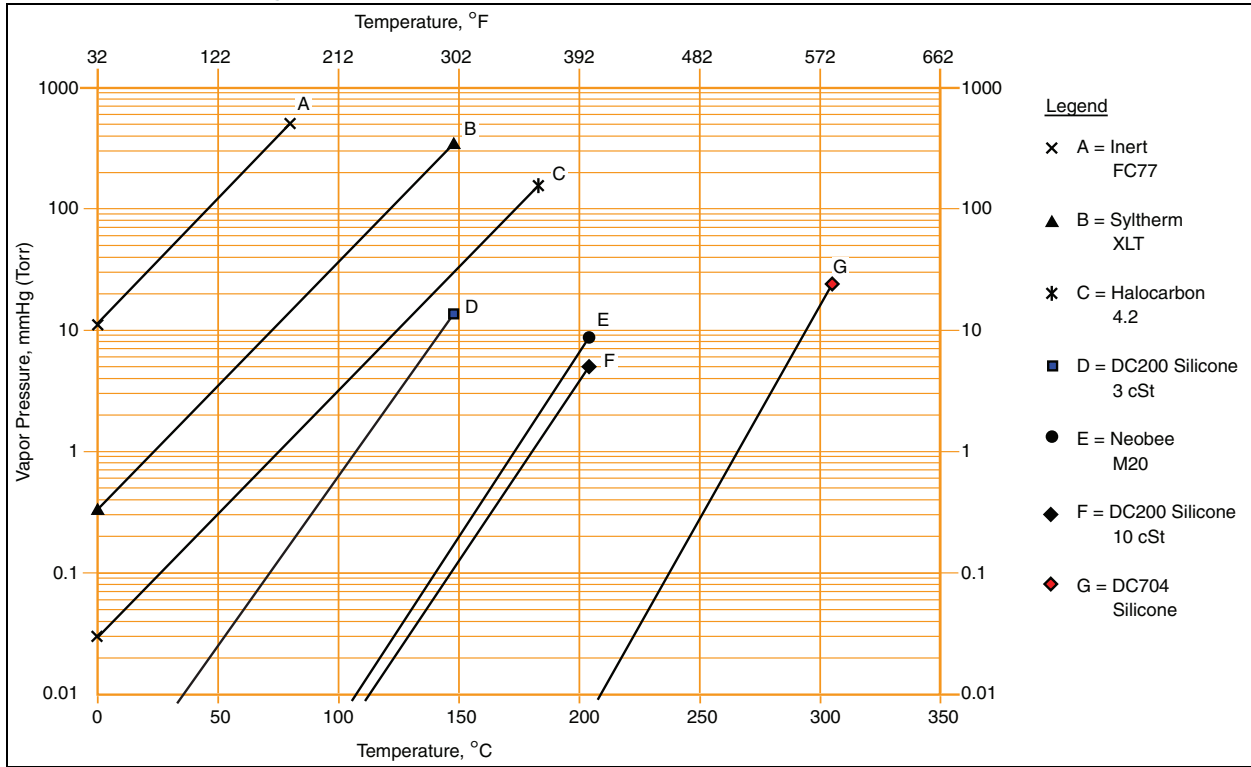

Table 2. Pressure Seals Used with I/A Series Pressure Transmitters

Seal Model	Seal Description	Process Connections
Direct Connect Pressure Seal Assemblies		
PSFLT	Flanged, Direct Connect (Flanged Level), Flush or Extended Diaphragm	ANSI Class 150/300/600 flanges and BS/DIN PN 10/40, 10/16, 25/40 flanges
PSFAD	Flanged, Direct Connect, Recessed Diaphragm	ANSI Class 150, 300, 600, 1500 flanges
PSFFD	Flanged, Direct Connect, Flush Diaphragm	ANSI Class 150/300/600 and PN 10/40
PSTAD	Threaded, Direct Connect, Recessed Diaphragm	¼, ½, ¾, 1, or 1½ NPT internal thread
PSISD	In-Line Saddle Weld, Direct Connect, Recessed Diaphragm	Lower housing of seal is in-line saddle welded to nominal 3- or 4-inch (and larger) Pipe
PSSCT	Sanitary, Direct Connect (Level Seal), Flush Diaphragm	Process Connection to Sanitary Piping with 2- or 3-inch Tri-Clamp type connector
PSSST	Sanitary, Direct Connect (Level Seal), Extended Diaphragm	Process Connection to 2-in Mini Spud or 4-in Standard Spud; Tri-Clamp type connector

Table 2. Pressure Seals Used with I/A Series Pressure Transmitters (Continued)

Seal Model	Seal Description	Process Connections
Remote Mount, Capillary-Connected Pressure Seal Assemblies		
PSFPS	Flanged, Remote Mount, Flush Diaphragm	ANSI Class 150/300/600 flanges and BS/DIN PN 10/40 flanges
PSFES	Flanged, Remote Mount, Extended Diaphragm	ANSI Class 150/300/600 flanges and BS/DIN PN 10/40, 10/16, 25/40 flanges
PSFAR	Flanged, Remote Mount, Recessed Diaphragm	ANSI Class 150/300/600/1500 flanges
PSFFR	Flanged, Remote Mount, Flush Diaphragm	ANSI Class 150/300/600 and PN 10/40
PSTAR	Threaded, Remote Mount, Recessed Diaphragm	¼, ½, ¾, 1, or 1½ NPT internal thread
PSISR	In-Line Saddle Weld, Remote Mount, Recessed Diaphragm	Lower housing of seal is in-line saddle welded to nominal 3- or 4-inch (and larger) Pipe
PSSCR	Sanitary, Remote Mount, Flush Diaphragm	Process Connection secured with a Tri-Clamp type connector to a 2- or 3-inch pipe
PSSSR	Sanitary, Remote Mount, Extended Diaphragm	Process Connection to 2-in Mini Spud or 4-in Standard Spud; Tri-Clamp type connector

Table 3. I/A Series Pressure Transmitters and Applicable Pressure Seals

Transmitter Model	Used with Pressure Seal Model:(a)														
	FLT	FAD	FFD	TAD	ISD	SCT	SST	FPS	FES	FAR	FFR	TAR	ISR	SCR	SSR
IAP10/IAP10S(b)	-	✓	✓	✓	✓	-	-	✓	✓	✓	✓	✓	✓	✓	✓
IAP20(b)	-	-	-	-	-	-	-	✓	✓	✓	✓	✓	✓	✓	✓
IGP10/IGP10S(b)	-	✓	✓	✓	✓	-	-	✓	✓	✓	✓	✓	✓	✓	✓
IGP20(b)	✓	-	-	-	-	✓	✓	✓	✓	✓	✓	✓	✓	✓	✓
IGP25(b)	-	✓	✓	✓	✓	-	-	✓	✓	✓	-	✓	✓	✓	✓
IGP50(c)	-	-	-	-	-	-	-	-	-	-	-	-	-	-	-
IDP10/IDP10S (b)	✓	-	-	-	-	✓	✓	✓	✓	✓	✓	✓	✓	✓	✓
IDP25(b)	✓	-	-	-	-	✓	✓	✓	✓	✓	✓	✓	✓	✓	✓
IDP50(b)	✓	-	-	-	-	✓	✓	✓	✓	✓	✓	✓	✓	✓	✓
IMV25(c)	-	-	-	-	-	-	-	-	-	-	-	-	-	-	-
IMV30(c)	-	-	-	-	-	-	-	-	-	-	-	-	-	-	-
IMV31(c)	-	-	-	-	-	-	-	-	-	-	-	-	-	-	-

(a) Pressure Seal models are shown with an abbreviated code; all seal codes have a PS prefix; for example, FLT is Model PSFLT.

(b) For applicable transmitter PSSs, see Tables 7 and 8 at the end of this document.

(c) Models IGP50, IMV25, IMV30, and IMV31 are not offered with seals. Contact Invensys for further information.

PSFLT SERIES - FLANGED, DIRECT CONNECT (FLANGED LEVEL) PRESSURE SEALS
WITH FLUSH OR EXTENDED DIAPHRAGM

Figure 2. PSFLT with flush and extended diaphragm seals



The PSFLT Series Seals, with flush or extended diaphragm, are direct connect flange mounted seals used with the IDP10, IDP10S, IDP25, IDP50, or IGP20 Transmitters for determination of liquid level, interface level, or density in open, pressurized, or evacuated vessels. This Transmitter-Seal System provides a reliable, precise measurement. For transmitter specifications, refer to the applicable transmitter PSS in Table 7 or 8 at the end of this document.

Table 4. Process Pressure-Temperature Limits - ANSI and BS/DIN Flanges

ANSI Carbon Steel and 316 SS Flanges(a)						
Process Temperature	Pressure Rating in psig - Carbon Steel			Pressure Rating in psig - 316 SS		
	Class 150	Class 300	Class 600	Class 150	Class 300	Class 600
-20 to 100°F	285	740	1480	275	720	1440
200°F	260	680	1360	235	620	1240
300°F	230	655	1310	215	560	1120
400°F(b)	200	635	1265	195	515	1025
BS/DIN Carbon Steel and 316 SS Flanges(a)						
Process Temperature	Pressure Rating in bar gauge - Carbon Steel			Pressure Rating in bar gauge - 316 SS		
	PN 10/40	PN 10/16	PN 25/40	PN 10/40	PN 10/16	PN 25/40
-10 to +100°C	40	16	40	40	16	40
150°C	37.5	14.5	37.5	36.3	14.5	36.3
200°C	35	13	35	33.7	13.4	33.7
250°C(b)	32	11	32	31.8	12.7	31.8

(a) Do not exceed the pressure-temperature limits of the various ANSI and BS/DIN flanges and materials listed in this table.
(b) Maximum temperature allowed is 204°C (400°F) for transmitter with PSFLT seals.

Temperature Limits - PSFLT with Fill Fluids

Fill Fluid	Temperature Limits
DC200, 10 cSt Silicone	-40 and +204°C (-40 and +400°F)
FC77, Inert	-59 and +82°C (-75 and +180°F)
DC200, 3 cSt Silicone	-40 and +149°C (-40 and +300°F)
DC704, Silicone	0 and 204°C (32 and 400°F)
Neobee M20	-18 and +204°C (0 and 400°F)
Halocarbon 4.2	-45 and +160°C (-49 and +320°F)
Syltherm XLT	-73 and +149°C (-100 and +300°F)

Connection to Transmitter

Flanged assembly bolted to high pressure side of transmitter and sealed with a Teflon gasket. A metallic, self-energizing O-ring is available for high vacuum service.

Process-Wetted Materials

FLUSH DIAPHRAGM

316L SS, nickel alloy (equivalent to Hastelloy C[®]-276), or Tantalum

EXTENDED DIAPHRAGM

316L SS or nickel alloy (equivalent to Hastelloy C[®]-276)

Ambient Temperature Effect - Transmitter with PSFLT Seal (see tables below)

Table 5. Total Effect for a 28°C (50°F) Change within Normal Operating Conditions

Transmitter Span Limit Code (a)	Total Ambient Temperature Effect for Transmitters with:	
	Electronics Versions “-D,” “-T,” “-F,” and “-V” (b)	Electronics Version “-A” only (b)
B and C	±(0.03% URL + 0.060% Span + “X”)	±(0.03% URL + 0.20% Span + “X”)
D only	±(0.05% URL + 0.045% Span + “X”)	±(0.05% URL + 0.18% Span + “X”)
E only	±(0.08% URL + 0.025% Span + “X”)	±(0.08% URL + 0.15% Span + “X”)

(a) Pressure seals are not applicable to transmitter Span Limit Code A.

(b) URL, Span, and “X” must be in identical units. See table below for Values of “X”

Table 6. Values of “X” for Ambient Temperature Effect Specifications

Flange Size		Value of “X” for Transmitter with a PSFLT Seal(a)			
		with a Flush Diaphragm		with an Extended Diaphragm	
mm	in	mmH ₂ O	inH ₂ O	mmH ₂ O	inH ₂ O
50	2	38	1.5	125	5
80	3	13	0.5	50	1.9
100	4	Not Applicable	Not Applicable	13	0.5

(a) Values listed are with seals filled with silicone DC200 or Inert fill fluids.

Approximate Transmitter and Seal Mass with ANSI Flanges

ANSI Flange Rating	Flange Size and Extension Length - Approximate Mass in Pounds (a)											
	2-in Flange Size				3-in Flange Size				4-in Flange Size			
	Flush	2-in	4-in	6-in	Flush	2-in	4-in	6-in	Flush	2-in	4-in	6-in
Class 150	17	19	20	22	24	28	31	35	N/A	36	42	49
Class 300	19	21	22	24	30	33	36	40	N/A	48	54	61
Class 600	21	23	24	26	33	37	40	44	N/A	60	66	72

(a) Add approximately 2 lb to values listed if a stainless steel housing is used.

Approximate Transmitter and Seal Mass with DIN/BS Flanges

DIN Flange Rating	Flange Size and Extension Length - Approximate Mass in Kilograms (a)											
	50 mm Flange Size				80 mm Flange Size				100 mm Flange Size			
	Flush	50 mm	100 mm	150 mm	Flush	50 mm	100 mm	150 mm	Flush	50 mm	100 mm	150 mm
PN 10/40	9	9	10	11	12	13	15	16	N/A	N/A	N/A	N/A
PN 10/16	N/A	N/A	N/A	N/A	N/A	N/A	N/A	N/A	N/A	14	17	20
PN 25/40	N/A	N/A	N/A	N/A	N/A	N/A	N/A	N/A	N/A	17	20	23

(a) Add approximately 1 kg to values listed if a stainless steel housing is used.

Dimensions - Nominal

See figure below and DP 020-342.

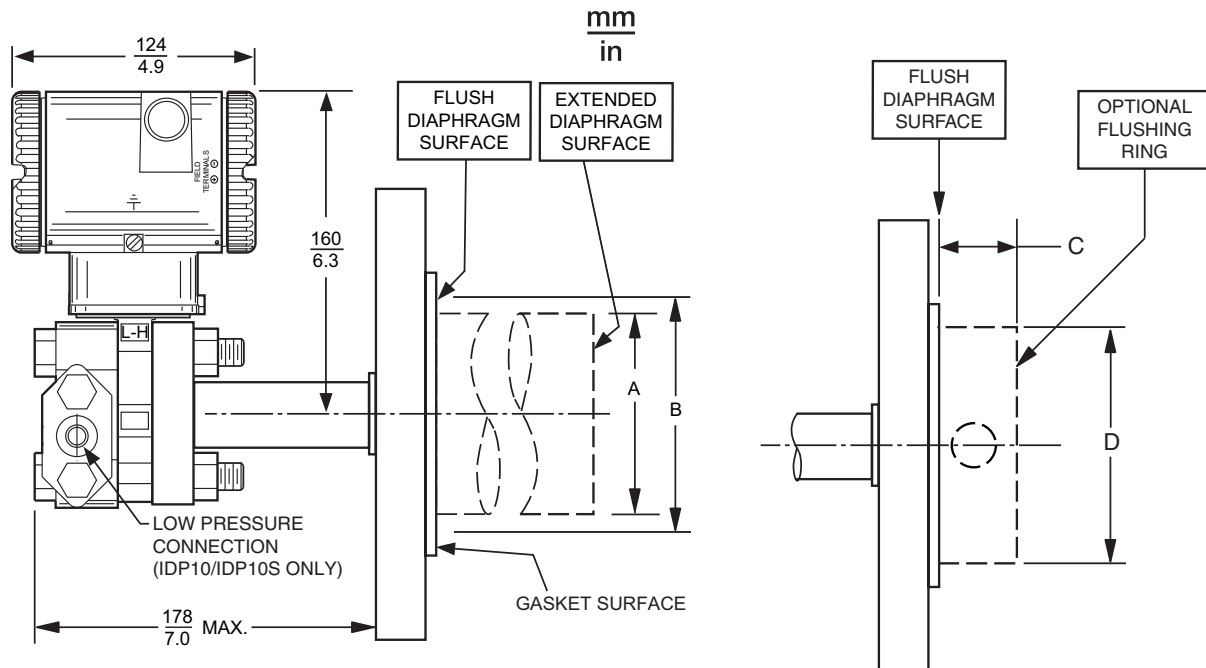

Dimensions “A” and “B”

Seal Type	Flange Size(a)	Dim. “A” Extended(b)	Dim. “B” Flush
Flush or Extended	<u>50</u> 2	<u>48.3</u> 1.90	<u>58</u> 2.3
Flush or Extended	<u>80</u> 3	<u>72.4</u> 2.85	<u>89</u> 3.5
Extended Only	<u>100</u> 4	<u>94</u> 3.7	N/A

Dimensions “C” and “D”

Seal Type	ANSI Flange	NPT Flushing Conn.	Dim. “C”	Dim. “D”
Flush	2 inch	¼ inch	1.00	3.62
		½ inch	1.50	3.62
	3 inch	¼ inch	1.00	5.00
		½ inch	1.50	5.00

(a) Flange dimensions are per ANSI and BS/DIN standards.

(b) Dimension “A” is optionally available with ANSI Class 150, 2- and 3-inch flanges as follows:

2-in Flange: 1.861 in (maximum)

3-in Flange: 2.792 in (maximum)

Notes

1. Gasket surface has serrated finish, except for tantalum seals.
2. Extended diaphragm is suitable for up to schedule 80 unlined pipe nozzle.
3. 50 mm (2 in), 100 mm (4 in), or 150 mm (6 in) extension, as specified.
4. With IDP10, IDP10S, IDP25, and IDP50 transmitters, a remote capillary connected seal may be added to the low pressure side.

MODEL CODE - PSFLT PRESSURE SEALS

Description			Model
Flanged, Direct Connect (Flanged Level) Pressure Seal - with Flush or Extended Diaphragm.			PSFLT
Seal Orientation			
Seal is for High Side of IDP10, IDP10S, IDP25, IDP50, or IGP20 Transmitters			-B
Structure Code (Flange Size, Extension Length, and Process Wetted Seal Material)			
Flange Size	Seal Wetted Material	Extension Length	
2 in (50 mm)	316L SS	Flush	2S0
2 in (50 mm)	Nickel alloy (equivalent to Hastelloy C®-276)	Flush	2C0
2 in (50 mm)	Tantalum	Flush	2T0
3 in (80 mm)	316L SS	Flush	3S0
3 in (80 mm)	Nickel alloy (equivalent to Hastelloy C®-276)	Flush	3C0
3 in (80 mm)	Tantalum	Flush	3T0
2 in (50 mm)	316L SS	2 in (50 mm)	2S2
2 in (50 mm)	Nickel alloy (equivalent to Hastelloy C®-276)	2 in (50 mm)	2C2
2 in (50 mm)	316L SS	4 in (100 mm)	2S4
2 in (50 mm)	Nickel alloy (equivalent to Hastelloy C®-276)	4 in (100 mm)	2C4
2 in (50 mm)	316L SS	6 in (150 mm)	2S6
2 in (50 mm)	Nickel alloy (equivalent to Hastelloy C®-276)	6 in (150 mm)	2C6
3 in (80 mm)	316L SS	2 in (50 mm)	3S2
3 in (80 mm)	Nickel alloy (equivalent to Hastelloy C®-276)	2 in (50 mm)	3C2
3 in (80 mm)	316L SS	4 in (100 mm)	3S4
3 in (80 mm)	Nickel alloy (equivalent to Hastelloy C®-276)	4 in (100 mm)	3C4
3 in (80 mm)	316L SS	6 in (150 mm)	3S6
3 in (80 mm)	Nickel alloy (equivalent to Hastelloy C®-276)	6 in (150 mm)	3C6
4 in (100 mm)	316L SS	2 in (50 mm)	4S2
4 in (100 mm)	Nickel alloy (equivalent to Hastelloy C®-276)	2 in (50 mm)	4C2
4 in (100 mm)	316L SS	4 in (100 mm)	4S4
4 in (100 mm)	Nickel alloy (equivalent to Hastelloy C®-276)	4 in (100 mm)	4C4
4 in (100 mm)	316L SS	6 in (150 mm)	4S6
4 in (100 mm)	Nickel alloy (equivalent to Hastelloy C®-276)	6 in (150 mm)	4C6
Flange Rating and Material (Not Process Wetted)			
ANSI Class 150, Carbon Steel			1
ANSI Class 300, Carbon Steel			2
ANSI Class 600, Carbon Steel			3
DIN and BS PN 10/40, Carbon Steel			A
DIN and BS PN 10/16, Carbon Steel			C
DIN and BS PN 25/40, Carbon Steel			D
ANSI Class 150, 316 SS			E
ANSI Class 300, 316 SS			F
ANSI Class 600, 316 SS			G
DIN and BS PN 10/40, 316 SS			H
DIN and BS PN 10/16, 316 SS			R
DIN and BS PN 25/40, 316 SS			T
Instrument Connection			
Bolted Construction			5
Fill Fluid - Pressure Seal			
Fill Fluid	Temperature Limits		
	°C	°F	
DC200, 10 cSt Silicone (a)	-40 and +204	-40 and +400	1
FC77, Inert	-59 and +82	-75 and +180	2
DC200, 3 cSt Silicone (a)	-40 and +149	-40 and +300	3
DC704, Silicone (a)	0 and 204	32 and 400	4

MODEL CODE - PSFLT PRESSURE SEALS (CONTINUED)

Description			Model
Fill Fluid - Pressure Seal (Contd.)			
Fill Fluid	Temperature Limits		
	°C	°F	
Neobee M20 (a)	-18 and +204	0 and 400	5
Halocarbon 4.2	-45 and +160	-49 and +320	6
Syltherm XLT-	-73 and +149	-100 and +300	7
Optional Selections			
Diaphragm Seal with Reduced Diameter Extension			
Diameter	Used with Structure and Flange Rating/Material Codes		
1.861 in (maximum)	2S21, 2S2E, 2S41, 2S4E, 2S61, 2S6E		-D2
2.792 in (maximum)	3S21, 3S2E, 3S41, 3S4E, 3S61, 3S6E		-D3
Gold Plated Diaphragm on Extended Diaphragm Diameter			
Diameter	Used with Structure and Flange Rating/Material Codes		
1.861 in (maximum)	2S21, 2S2E, 2S41, 2S4E, 2S61, 2S6E		-G2
2.792 in (maximum)	3S21, 3S2E, 3S41, 3S4E, 3S61, 3S6E		-G3
Gold Plated Diaphragm (b)			
Flushing Rings (Used with Flush Seals Only)			
Size	Connection	Material	
2 in (c)	¼ NPT	316L SS	-FA
2 in (c)	¼ NPT	316L SS with NPT Plug	-FB
3 in (d)	¼ NPT	316L SS	-FC
3 in (d)	¼ NPT	316L SS with NPT Plug	-FD
2 in (c)	¼ NPT	Nickel alloy (equivalent to Hastelloy C®-276)	-FE
2 in (c)	¼ NPT	Nickel alloy (equivalent to Hastelloy C®-276) with NPT Plug	-FF
3 in (d)	¼ NPT	Nickel alloy (equivalent to Hastelloy C®-276)	-FG
3 in (d)	¼ NPT	Nickel alloy (equivalent to Hastelloy C®-276) with NPT Plug	-FH
2 in (c)	½ NPT	316L SS	-FJ
2 in (c)	½ NPT	316L SS with NPT Plug	-FK
3 in (d)	½ NPT	316L SS	-FL
3 in (d)	½ NPT	316L SS with NPT Plug	-FM
2 in (c)	½ NPT	Nickel alloy (equivalent to Hastelloy C®-276)	-FN
2 in (c)	NPT	Nickel alloy (equivalent to Hastelloy C®-276) with NPT Plug	-FP
3 in (d)	½ NPT	Nickel alloy (equivalent to Hastelloy C®-276)	-FQ
3 in (d)	½ NPT	Nickel alloy (equivalent to Hastelloy C®-276) with NPT Plug	-FR
2 in (c)	Dual ¼ NPT	316L SS	-FS
2 in (c)	Dual ¼ NPT	316L SS with NPT Plugs	-FT
3 in (d)	Dual ¼ NPT	316L SS	-FU
3 in (d)	Dual ¼ NPT	316L SS with NPT Plugs	-FV
2 in (c)	Dual ¼ NPT	Nickel alloy (equivalent to Hastelloy C®-276)	-FW
2 in (c)	Dual ¼ NPT	Nickel alloy (equivalent to Hastelloy C®-276) with NPT Plugs	-FX
3 in (d)	Dual ¼ NPT	Nickel alloy (equivalent to Hastelloy C®-276)	-FY
3 in (d)	Dual ¼ NPT	Nickel alloy (equivalent to Hastelloy C®-276) with NPT Plugs	-FZ
2 in (c)	Dual ½ NPT	316L SS	-GA
2 in (c)	Dual ½ NPT	316L SS with NPT Plugs	-GB
3 in (d)	Dual ½ NPT	316L SS	-GC
3 in (d)	Dual ½ NPT	316L SS with NPT Plugs	-GD
2 in (c)	Dual ½ NPT	Nickel alloy (equivalent to Hastelloy C®-276)	-GE
2 in (c)	Dual ½ NPT	Nickel alloy (equivalent to Hastelloy C®-276) with NPT Plugs	-GF
3 in (d)	Dual ½ NPT	Nickel alloy (equivalent to Hastelloy C®-276)	-GG
3 in (d)	Dual ½ NPT	Nickel alloy (equivalent to Hastelloy C®-276) with NPT Plugs	-GH

(a) Requires silicone fill in transmitter's sensor.

(b) Option -GP is not available with PSFLT...T.

(c) Restricted to model codes containing PSFLT-2.....

(d) Restricted to model codes containing PSFLT-3.....

ORDERING INSTRUCTIONS

1. Transmitter Model Number from applicable Transmitter PSS
 e.g., IDP10-DF1C01F-M1L1C1W
 └─ Flanged Level, HI Side of PSFLT Transmitter, Silicone Fill in Sensor

2. Pressure Seal Model Number from this PSS
 e.g., PSFLT-B2S0153
 └─ Silicone Fill
 └─ HI Side Seal of IDP10 Transmitter

PSFPS AND PSFES SERIES - FLANGED CONNECTION, REMOTE MOUNT PRESSURE SEALS WITH FLUSH OR EXTENDED DIAPHRAGM

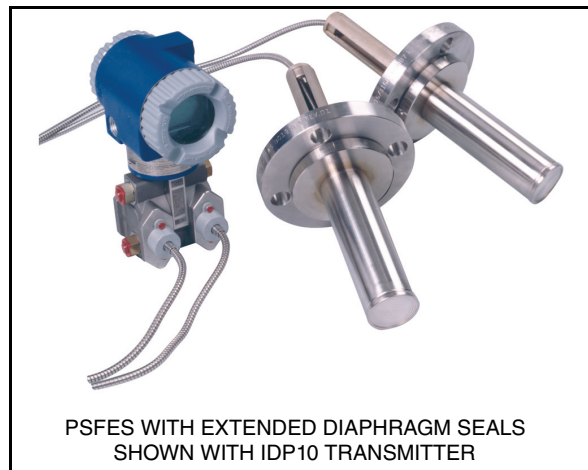

The PSFPS and PSFES with remote mount, flush or extended diaphragm seals are used with the IAP10, IAP10S, IGP10, IGP25, IAP20, IGP20, IDP10, IDP10S, IDP25, and IDP50 Transmitters. The transmitter can be mounted in a remote location with interconnecting capillary lengths up to 15 m (50 ft). This Transmitter-Seal System provides a reliable, precise measurement. For transmitter specifications, refer to the applicable transmitter PSS in Table 7 or 8 at the end of this document.

Temperature Limits - Fill Fluids

Fill Fluid	Temperature Limits
DC200, 10 cSt Silicone	-40 and +204°C (-40 and +400°F)
FC77, Inert	-59 and +82°C (-75 and +180°F)
DC200, 3 cSt Silicone	-40 and +149°C (-40 and +300°F)
DC704, Silicone	0 and 304°C (32 and 580°F)
Neobee M20	-18 and +204°C (0 and 400°F)
Halocarbon 4.2	-45 and +160°C (-49 and +320°F)
Syltherm XLT	-73 and +149°C (-100 and +300°F)

Connection to Transmitter

Capillaries are provided in lengths from 1.5 to 15 m (5 to 50 ft) with 300 Series flexible armor. The armor is provided with or without a protective coat.

Process-Wetted Materials

FLUSH DIAPHRAGM SEAL

316L SS, Nickel alloy (equivalent to Hastelloy® C-276), or Tantalum

EXTENDED DIAPHRAGM SEAL

316L SS or Nickel alloy (equivalent to Hastelloy® C-276)

Seal Orientation

One or two seals, depending on the transmitter used. See Model Code further in document.

Ambient Temperature Effect and Response Time

See performance data section at end of this document.

Process Pressure-Temperature Limits - ANSI and DIN/BS Flanges

ANSI Carbon Steel and 316 SS Flanges (a)						
Process Temperature	Pressure Rating in psig - Carbon Steel			Pressure Rating in psig - 316 SS		
	Class 150	Class 300	Class 600	Class 150	Class 300	Class 600
-20 to 100°F	285	740	1480	275	720	1440
200°F	260	680	1360	235	620	1240
300°F	230	655	1310	215	560	1120
400°F	200	635	1265	195	515	1025
500°F	170	605	1205	170	480	955
600°F (b)	140	570	1135	140	450	900

DIN/BS Carbon Steel and 316 SS Flanges (a)						
Process Temperature	Pressure Rating in bar gauge - Carbon Steel			Pressure Rating in bar gauge - 316 SS		
	PN 10/40	PN 10/16	PN 25/40	PN 10/40	PN 10/16	PN 25/40
-10 to +100°C	40	16	40	40	16	40
150°C	37.5	14.5	37.5	36.3	14.5	36.3
200°C	35	13	35	33.7	13.4	33.7
250°C	32	11	32	31.8	12.7	31.8
300°C (b)	30	9	30	29.7	11.8	29.7
350°C (b)	27.8	7.5	27.8	28.5	11.4	28.5

(a) Do not exceed the pressure-temperature limits of the various ANSI and BS/DIN flanges and materials listed in this table.

(b) Maximum temperature allowed is 304°C (580°F) when using DC704 Silicone fill. See table below for temperature limits of other fill fluids.

Approximate Transmitter Mass with PSFPS or PSFES Remote Seals with ANSI Flanges - Dual Seals each with a 5-foot Capillary

ANSI Flange Rating	Flange Size and Extension Length - Approximate Mass in Pounds (a)											
	2-in Flange Size				3-in Flange Size				4-in Flange Size			
	Flush	2 in	4 in	6 in	Flush	2 in	4 in	6 in	Flush	2 in	4 in	6 in
Class 150	39	40	41	43	55	58	61	65	N/A	90	96	102
Class 300	43	44	46	47	67	70	74	77	N/A	112	118	124
Class 600	47	49	50	52	76	79	82	86	N/A	143	149	155

(a) Add approximately 2 lb to values listed if a stainless steel housing is used.

Approximate Transmitter Mass with PSFPS or PSFES Seal with BS/DIN Flanges - Dual Seals each with a 1.5-meter Capillary

DIN Flange Rating	Flange Size and Extension Length - Approximate Mass in Kilograms (a)											
	50 mm Flange Size				80 mm Flange Size				100 mm Flange Size			
	Flush	50 mm	100 mm	150 mm	Flush	50 mm	100 mm	150 mm	Flush	50 mm	100 mm	150 mm
PN 10/40	18	19	20	21	26	28	29	31	N/A	N/A	N/A	N/A
PN 10/16	N/A	N/A	N/A	N/A	N/A	N/A	N/A	N/A	N/A	32	35	38
PN 25/40	N/A	N/A	N/A	N/A	N/A	N/A	N/A	N/A	N/A	41	44	46

(a) Add approximately 1 kg to values listed if a stainless steel housing is used.

NOTE

The approximate mass values listed in the tables above are for an IDP10, IDP10S, IDP25, or IDP50 transmitter with an aluminum housing and process connectors. The mass for this transmitter (without capillaries or seals) is 4.2 kg (9.2 lb). Therefore, the mass is mostly determined by the capillary and flange configurations selected, and not by the transmitter itself.

Dimensions - Nominal

See figure below and DP 020-343.

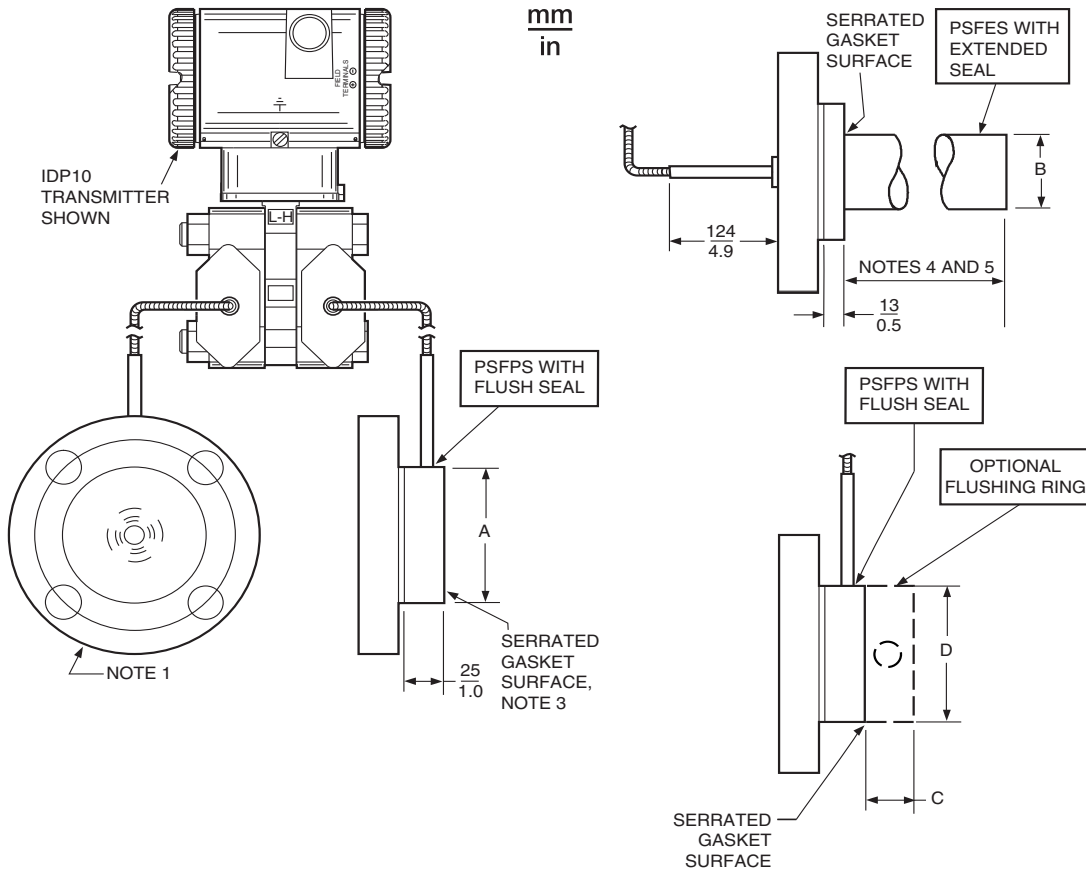

Dimensions “A” and “B”

Seal Type	Flange Size	Dim. “A” Flush	Dim. “B” Extended
Flush or Extended	<u>50</u> 2	<u>99</u> 3.9	<u>47.3</u> 1.90
Flush or Extended	<u>80</u> 3	<u>132</u> 5.2	<u>72.4</u> 2.85
Extended Only	<u>100</u> 4	N/A	<u>94</u> 3.7

Dimensions “C” and “D”

Seal Type	ANSI Flange	NPT Flushing Conn.	Dim. “C”	Dim. “D”
Flush	2 inch	¼ inch	1.00	3.62
		½ inch	1.50	3.62
	3 inch	¼ inch	1.00	5.00
		½ inch	1.50	5.00

NOTES

1. Flange dimensions are per ANSI or DIN/BS standards.
2. See applicable transmitter dimensional print for transmitter dimensions.
3. Gasket surface has serrated finish, except for tantalum seals.
4. Extended diaphragm is suitable for up to schedule 80 unlined pipe nozzle.
5. 50 mm (2 in), 100 mm (4 in), or 150 mm (6 in) extension, as specified.

MODEL CODE - PSFPS PRESSURE SEALS

Description	Model		
Flanged, Remote Mount, Flush Diaphragm Pressure Seals	PSFPS		
Seal Orientation			
Two Seal System, Balanced, Identical Model Numbered Seal on both Sides, IDP10, IDP10S, IDP25, and IDP50 Transmitters (a)	-A		
One Seal System, High Side, IDP10, IDP10S, IDP25, IDP50, IGP20, or IAP20 Transmitters	-B		
One Seal System, Low Side, IDP10, IDP10S, IDP25, or IDP50 Transmitters	-C		
One Seal System, IGP10, IGP25, or IAP10/IAP10S Transmitters	-D		
Structure Code - Flange Size, Extension Length, and Process Wetted Seal Material			
Flange Size Seal Wetted Material			
50 mm (2 in) 316L SS Flush	2S0		
50 mm (2 in) Nickel alloy (equivalent to Hastelloy C®-276) Flush	2C0		
50 mm (2 in) Tantalum Flush	2T0		
80 mm (3 in) 316L SS Flush	3S0		
80 mm (3 in) Nickel alloy (equivalent to Hastelloy C®-276)Flush	3C0		
80 mm (3 in) Tantalum Flush	3T0		
Flange Rating and Material (Not Process Wetted)			
ANSI Class 150, Carbon Steel	1		
ANSI Class 300, Carbon Steel	2		
ANSI Class 600, Carbon Steel	3		
DIN and BS PN 10/40 (for 50 and 80 mm only), Carbon Steel	A		
ANSI Class 150, 316 SS	E		
ANSI Class 300, 316 SS	F		
ANSI Class 600, 316 SS	G		
DIN and BS PN 10/40 (for 50 and 80 mm only), 316 SS	H		
Flange Provided by User	Y		
Instrument Connections			
Low Volume; capillary welded at both instrument and seal	3		
Fill Fluid - Pressure Seal and Capillary			
Fill Fluid Temperature Limits			
	°C °F		
DC200, 10 cSt Silicone	-40 and +204 -40 and +400	1	
FC77, Inert (c)	-59 and +82 -75 and +180	2	
DC200, 3 cSt Silicone	-40 and +149 -40 and +300	3	
DC704, Silicone	0 and 304 32 and 580	4	
Neobee M20	-18 and +204 0 and 400	5	
Halocarbon 4.2	-45 and +160 -49 and +320	6	
Syltherm XLT	-73 and +149 -100 and +300	7	
Capillary Internal Diameter			
0.027 inches; Not Available with DC704 Silicone, Fill Fluid Code 4	3		
0.040 inches	4		
0.062 inches; Not Available with IAP10/IAP10S, IGP10/IGP10S, or IGP25 Transmitters	6		
Flushing Rings			
Size Connection Material			
2 in (e)	Dual ¼ NPT	Nickel alloy (equivalent to Hastelloy C®-276)	-FW
2 in (e)	Dual ¼ NPT	Nickel alloy (equivalent to Hastelloy C®-276) with NPT Plugs	-FX
3 in (f)	Dual ¼ NPT	Nickel alloy (equivalent to Hastelloy C®-276)	-FY
3 in (f)	Dual ¼ NPT	Nickel alloy (equivalent to Hastelloy C®-276) with NPT Plugs	-FZ

MODEL CODE - PSFPS PRESSURE SEALS (CONTINUED)

Description			Model
2 in (e)	Dual ½ NPT	316L SS	-GA
2 in (e)	Dual ½ NPT	316L SS with NPT Plugs	-GB
3 in (f)	Dual ½ NPT	316L SS	-GC
3 in (f)	Dual ½ NPT	316L SS with NPT Plugs	-GD
2 in (e)	Dual ½ NPT	Nickel alloy (equivalent to Hastelloy C®-276)	-GE
2 in (e)	Dual ½ NPT	Nickel alloy (equivalent to Hastelloy C®-276) with NPT Plugs	-GF
3 in (f)	Dual ½ NPT	Nickel alloy (equivalent to Hastelloy C®-276)	-GG
3 in (f)	Dual ½ NPT	Nickel alloy (equivalent to Hastelloy C®-276) with NPT Plugs	-GH
Gold Plated Extended Diaphragm (b)			-GP

- (a) Specify quantity of 2 identical seals when Seal Orientation Code "A" is specified.
- (b) Option -GP is not available with PSFLT-.T.
- (c) Inert FC77 (Flourinert) fill is not available with IAP10, IAP10S or IAP20 transmitters. Use Halocarbon 4.2 fill.
- (d) For model codes PSFPS-.2....6, the maximum capillary length is 35 ft.
- (e) Restricted to model codes containing PSFPS-.2.....
- (f) Restricted to model codes containing PSFPS-.3.....

**ORDERING INSTRUCTIONS
(FOR TRANSMITTER WITH PSFPS SEALS)**

1. Applicable Transmitter Model Number (See Transmitter PSS)

e.g., IDP10-DS1C01F-X1Z3K1

└ Remote Seal, HI and LO Sides, Silicone Fill in Sensor

2. Pressure Seal Model Number from this PSS

e.g., PSFPS-A2S01334H (Quantity of 2 Required)

└ Silicone Fill

└ Two Seal System, Both Sides of IDP10 Transmitter

MODEL CODE - PSFES PRESSURE SEALS

<u>Description</u>			<u>Model</u>
Flanged, Remote Mount, Flush Diaphragm Pressure Seals			PSFES
<u>Seal Orientation</u>			
Two Seal System, Balanced, Identical Model Numbered Seal on both Sides, IDP10/IDP10S, IDP25, and IDP50 Transmitters (a)			-A
One Seal System, High Side, IDP10/IDP10S, IDP25, IDP50, IGP20, or IAP20 Transmitters			-B
One Seal System, Low Side, IDP10/IDP10S, IDP25, or IDP50 Transmitters			-C
One Seal System, IGP10, IGP25, or IAP10/IAP10S Transmitters			-D
<u>Structure Code - Flange Size, Extension Length, and Process Wetted Seal Material</u>			
Flange Size	Seal Wetted Material	Extension Length	
50 mm (2 in)	316L SS	50 mm (2 in)	2S2
50 mm (2 in)	Nickel alloy (equivalent to Hastelloy C®-276)	50 mm (2 in)	2C2
50 mm (2 in)	316L SS	100 mm (4 in)	2S4
50 mm (2 in)	Nickel alloy (equivalent to Hastelloy C®-276)	100 mm (4 in)	2C4
50 mm (2 in)	316L SS	150 mm (6 in)	2S6
50 mm (2 in)	Nickel alloy (equivalent to Hastelloy C®-276)	150 mm (6 in)	2C6
80 mm (3 in)	316L SS	50 mm (2 in)	3S2
80 mm (3 in)	Nickel alloy (equivalent to Hastelloy C®-276)	50 mm (2 in)	3C2
80 mm (3 in)	316L SS	100 mm (4 in)	3S4
80 mm (3 in)	Nickel alloy (equivalent to Hastelloy C®-276)	100 mm (4 in)	3C4
80 mm (3 in)	316L SS	150 mm (6 in)	3S6
80 mm (3 in)	Nickel alloy (equivalent to Hastelloy C®-276)	150 mm (6 in)	3C6
100 mm (4 in)	316L SS	50 mm (2 in)	4S2
100 mm (4 in)	Nickel alloy (equivalent to Hastelloy C®-276)	50 mm (2 in)	4C2
100 mm (4 in)	316L SS	100 mm (4 in)	4S4
100 mm (4 in)	Nickel alloy (equivalent to Hastelloy C®-276)	100 mm (4 in)	4C4
100 mm (4 in)	316L SS	150 mm (6 in)	4S6
100 mm (4 in)	Nickel alloy (equivalent to Hastelloy C®-276)	150 mm (6 in)	4C6
<u>Flange Rating and Material (Not Process Wetted)</u>			
ANSI Class 150, Carbon Steel			1
ANSI Class 300, Carbon Steel			2
ANSI Class 600, Carbon Steel			3
DIN and BS PN 10/40 (for 50 and 80 mm only), Carbon Steel			A
DIN and BS PN 10/16 (for 100 mm only), Carbon Steel			C
DIN and BS PN 25/40 (for 100 mm only), Carbon Steel			D
ANSI Class 150, 316 SS			E
ANSI Class 300, 316 SS			F
ANSI Class 600, 316 SS			G
DIN and BS PN 10/40 (for 50 and 80 mm only), 316 SS			H
DIN and BS PN 10/16 (for 100 mm only), 316 SS			R
DIN and BS PN 25/40 (for 100 mm only), 316 SS			T
<u>Instrument Connections</u>			
Low Volume; capillary welded at both instrument and seal			3
<u>Fill Fluid - Pressure Seal and Capillary</u>			
Fill Fluid	Temperature Limits		
	°C	°F	
DC200, 10 cSt Silicone	-40 and +204	-40 and +400	1
FC77, Inert (b)	-59 and +82	-75 and +180	2
DC200, 3 cSt Silicone	-40 and +149	-40 and +300	3
DC704, Silicone	0 and 304	32 and 580	4

MODEL CODE - PSFES PRESSURE SEALS (CONTINUED)

<u>Description</u>	<u>Model</u>
Neobee M20 -18 and +204 0 and 400	5
Halocarbon 4.2 -45 and +160 -49 and +320	6
Syltherm XLT -73 and +149 -100 and +300	7
Capillary Internal Diameter	
0.027 inches; Not Available with DC704 Silicone, Fill Fluid Code 4	3
0.040 inches	4
0.062 inches; Not Available with IAP10/IAP10S, IGP10/IGP10S, or IGP25 Transmitters (c)(e)	6
Capillary Length and Type	
1.5 m (5 ft) 300 Series SS Flexible Armor	A
3.0 m (10 ft) 300 Series SS Flexible Armor	B
4.5 m (15 ft) 300 Series SS Flexible Armor	C
6.0 m (20 ft) 300 Series SS Flexible Armor	D
7.5 m (25 ft) 300 Series SS Flexible Armor (c)	E
9.0 m (30 ft) 300 Series SS Flexible Armor (c)	F
10.5 m (35 ft) 300 Series SS Flexible Armor (c) (d)	S
12.0 m (40 ft) 300 Series SS Flexible Armor (c) (d)	T
13.5 m (45 ft) 300 Series SS Flexible Armor (c) (d) (e)	U
15.0 m (50 ft) 300 Series SS Flexible Armor (c) (d) (e)	V
1.5 m (5 ft) 300 Series SS Flexible Armor, Protective Coat	G
3.0 m (10 ft) 300 Series SS Flexible Armor, Protective Coat	H
4.5 m (15 ft) 300 Series SS Flexible Armor, Protective Coat	J
6.0 m (20 ft) 300 Series SS Flexible Armor, Protective Coat	K
7.5 m (25 ft) 300 Series SS Flexible Armor, Protective Coat (c)	L
9.0 m (30 ft) 300 Series SS Flexible Armor, Protective Coat (c)	M
10.5 m (35 ft) 300 Series SS Flexible Armor, Protective Coat (c) (d)	N
12.0 m (40 ft) 300 Series SS Flexible Armor, Protective Coat (c) (d)	P
13.5 m (45 ft) 300 Series SS Flexible Armor, Protective Coat (c) (d) (e)	Q
15.0 m (50 ft) 300 Series SS Flexible Armor, Protective Coat (c) (d) (e)	R
Optional Selections	
Extended Diaphragm Diameter Reduced to:	
Diameter Used with Structure and Flange Rating/Material Codes	
1.861 in (maximum) 2S21, 2S2E, 2S41, 2S4E, 2S61, 2S6E	-D2
2.792 in (maximum) 3S21, 3S2E, 3S41, 3S4E, 3S61, 3S6E	-D3
Extended Gold Plated Diaphragm Diameter Reduced to:	
Diameter Used with Structure and Flange Rating/Material Codes	
1.861 in (maximum) 2S21, 2S2E, 2S41, 2S4E, 2S61, 2S6E	-G2
2.792 in (maximum) 3S21, 3S2E, 3S41, 3S4E, 3S61, 3S6E	-G3
Gold Plated Diaphragm (b)	-GP

(a) Specify quantity of 2 identical seals when Seal Orientation Code "A" is specified.

(b) Inert FC77 (Flourinert) fill is not available with IAP10/IAP10S or IAP20 transmitters. Use Halocarbon 4.2 fill.

(c) Not applicable with PSFES-.2.....6. (maximum capillary length is 20 ft with 0.62 capillary ID).

(d) Not applicable with PSFES-.2..... (maximum capillary length is 30 ft with 2-inch extended seal).

(e) Not applicable with PSFES-.3.....6. (maximum capillary length is 20 ft with 0.62 capillary ID).

ORDERING INSTRUCTIONS(FOR TRANSMITTER WITH PSFES SEALS)

1. Applicable Transmitter Model Number (See Transmitter PSS)

e.g., IDP10-DS1C01F-X1Z3K1

└ Remote Seal, HI and LO Sides, Silicone Fill in Sensor

2. Pressure Seal Model Number from this PSS

e.g., PSFES-A2S21334H (Quantity of 2 Required)

└ Silicone Fill

└ Two Seal System of IDP10 Transmitter

PSFAR AND PSFAD SERIES, FLANGED CONNECTION, REMOTE MOUNT OR DIRECT CONNECT PRESSURE SEALS WITH RECESSED DIAPHRAGMS

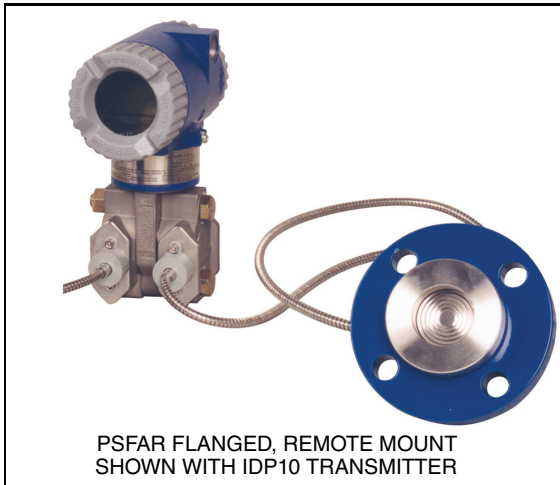

The PSFAR, with remote mount, flanged recessed diaphragm seals, is used with the IDP10, IDP10S, IDP25, IDP50, IAP10, IAP10S, IAP20, IGP10, IGP10S, IGP20, or IGP25 Transmitters. The PSFAR transmitter can be mounted in a remote location with interconnecting capillary lengths up to 15 m (50 ft). The PSFAD, with direct connect, recessed diaphragm seals, is used with the IGP10, IGP25, and IAP10 Transmitters. These Transmitter-Seal Systems provide precise, reliable measurements. For transmitter specifications, refer to the applicable transmitter PSS in Table 7 or 8 at the end of this document.

**Pressure-Temperature Ratings(a)(b)
ANSI Carbon Steel Flanges**

Process Temp.	Pressure Rating in psig			
	Cl. 150	Cl. 300	Cl. 600	Cl. 1500
-20°F to +100°F	285	740	1480	3705
200°F	260	680	1360	3395
300°F	230	655	1310	3270
400°F (a)	200	635	1265	3170
500°F	170	605	1205	3015
600°F (b)	140	570	1135	2840

(a) Maximum temperature limit with PSFAD is 204°C (400°F).
(b) Maximum temperature limit with PSFAR is 304°C (580°F).

**Pressure-Temperature Ratings(a)(b)
ANSI 316 SS Flanges**

Process Temp.	Pressure Rating in psig			
	Cl. 150	Cl. 300	Cl. 600	Cl. 1500
-20°F to +100°F	275	720	1440	3600
200°F	235	620	1240	3095
300°F	215	560	1120	2795
400°F (a)	195	515	1025	2570
500°F	170	480	955	2390
600°F (b)	140	450	900	2255

(a) Maximum temperature limit with PSFAD is 204°C (400°F).
(b) Maximum temperature limit with PSFAR is 304°C (580°F).

NOTES

1. When a non-metallic lower housing is used, the maximum working pressure allowed is 150 psig (1035 kPa).
2. Do not exceed the flange pressure-temperature limits listed in the adjacent tables.

Fill Fluid-Pressure Seal and Capillary

Fill Fluid	Temperature Limits
DC200, 10 cSt Silicone	-40 and +204°C (-40 and +400°F)
FC77, Inert	-59 and +82°C (-75 and +180°F)
DC200, 3 cSt Silicone	-40 and +149°C (-40 and +300°F)
DC704, Silicone	0 and 304°C (32 and 580°F)(a)
Neobee M20	-18 and +204°C (0 and 400°F)
Halocarbon 4.2	-45 and +160°C (-49 and +320°F)
Syltherm XLT	-73 and +149°C (-100 and +300°F)

(a) When used with a direct connect PSFAD seal, the temperature limit is reduced to 204°C (400°F).

Process Wetted Materials

A wide selection of process wetted materials is available. Materials for lower housings and diaphragm include 316L SS, nickel alloy (equivalent to Hastelloy C®-276), Inconel 600, Titanium, and others as indicated in the model code selections. Also, lower housings are available in non-metallics such as PVC and Teflon. The standard gasket between the lower housing and the seal is an organic fiber with nitrile binder (Klinger C-4401). Other gasket materials such as Grafoil, Teflon, Viton, and Buna N are also available.

Seal Orientation

Seal can be on HI or LO side, or both sides depending on transmitter used. See Model Code.

Connection to Process

Depends on process connector. Seal is attached to process flange using bolts or studs located on the lower housing. See Dimensions section below.

Connection to Transmitter

REMOTE MOUNT (PSFAR ONLY)

Low volume; welded to capillary connection at both the transmitter and seal.

DIRECT MOUNT (PSFAD ONLY)

A ½ NPT internal thread on flange ring/upper housing directly connects to an IGP10/IGP10S, IGP25, or IAP10/IAP10S transmitter.

Ambient Temperature Effect and Response Time

Applicable to remote, capillary connected seals only. See PERFORMANCE DATA at end of this document.

Dimensions - Nominal

See figures below and DP 020-345 and DP 020-346.

BOLT MOUNTING CONSTRUCTION

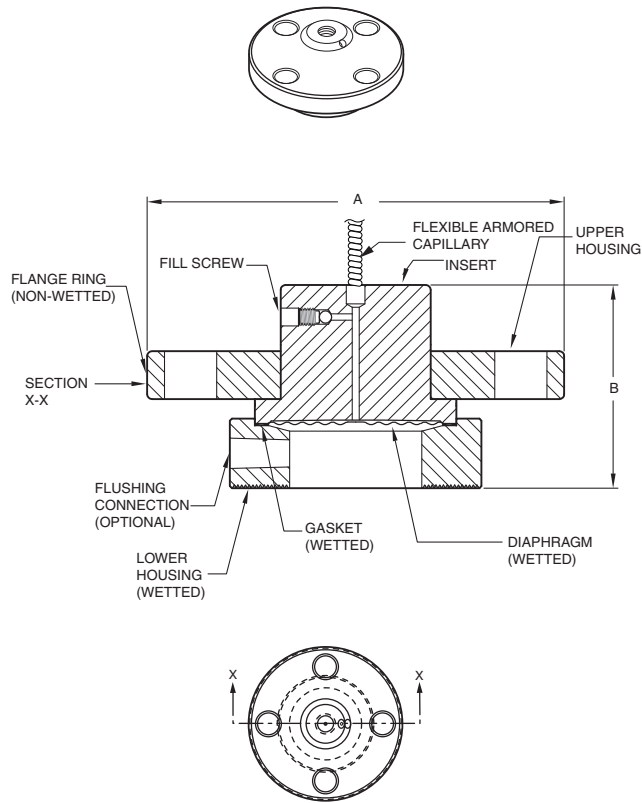

STUD MOUNTING CONSTRUCTION

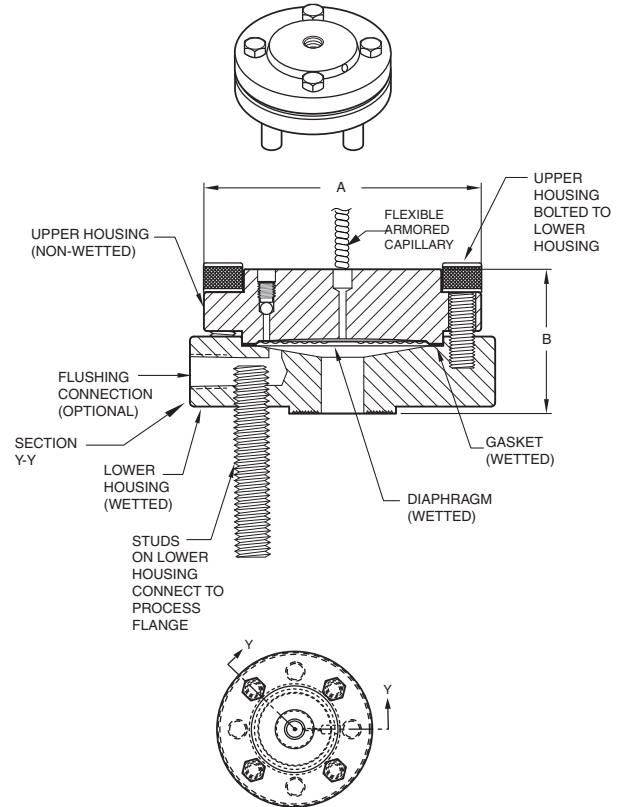

NOTE

See tables on next page for Dimensions A and B.

**2.4 in Diaphragm
Stud Mounting Construction
PSFAR AND PSFAD**

ANSI Flange	A	B
½ in, Cl. 150	3.50	1.94
½ in, Cl. 300	3.50	1.98
¾ in, Cl. 150	3.50	1.94
¾ in, Cl. 300	3.50	1.98

**2.9 in Diaphragm
Stud Mounting Construction
PSFAR AND PSFAD**

ANSI Flange	A	B
½ in, Cl. 150	4.00	2.10
½ in, Cl. 300	4.00	2.20
¾ in, Cl. 150	4.00	2.10
¾ in, Cl. 300	4.00	2.20
1 in, Cl. 150	4.00	1.90
1 in, Cl. 300	4.00	1.90
1½ in, Cl. 150	5.00	2.80
1½ in, Cl. 300	6.12	2.80

**4.1 in Diaphragm
Stud Mounting Construction
PSFAR Only**

ANSI Flange	A	B
½ in, Cl. 150	5.25	1.90
½ in, Cl. 300	5.25	2.10
¾ in, Cl. 150	5.25	1.90
¾ in, Cl. 300	5.25	1.90
1 in, Cl. 150	5.25	2.10
1 in, Cl. 300	5.25	2.10
1½ in, Cl. 150	5.25	2.10
1½ in, Cl. 300	5.25	2.40
2 in, Cl. 150	6.00	2.30

**2.4 in Diaphragm
Bolt Mounting Construction
PSFAR AND PSFAD**

ANSI Flange	A	B
1 in, Cl. 150	4.25	2.0
1 in, Cl. 300	4.88	2.5
1½ in, Cl. 150	5.00	3.10
1½ in, Cl. 300	6.12	3.10
2 in, Cl. 150	6.00	3.10
2 in, Cl. 300	6.50	3.10
3 in, Cl. 150	7.50	3.20
3 in, Cl. 300	8.25	3.50

**2.9 in Diaphragm
Bolt Mounting Construction
PSFAR AND PSFAD**

ANSI Flange	A	B
1½ in, Cl. 150	5.00	2.80
1½ in, Cl. 300	6.12	2.80
2 in, Cl. 150	6.00	2.80
2 in, Cl. 300	6.50	2.80
3 in, Cl. 150	7.50	3.20
3 in, Cl. 300	8.25	3.20

**4.1 in Diaphragm
Bolt Mounting Construction
PSFAR Only**

ANSI Flange	A	B
2 in, Cl. 300	6.50	3.00
3 in, Cl. 150	7.50	2.90
3 in, Cl. 300	8.25	2.90

NOTE

The dimensions in the tables above are in inches and are for ANSI Class 150 and 300 flanges. Contact Invensys if dimensions for the other flange types and sizes are required.

MODEL CODE - PSFAR PRESSURE SEALS

Description	Model
Flanged, Remote Mount, Recessed Diaphragm Seals	PSFAR
Seal Orientation	
Two Seal System, Balanced - Same Seal on both Sides, IDP10/IDP10S, IDP25, or IDP50 Transmitters (a)	-A
One Seal System, High Side, IDP10/IDP10S, IDP25, IDP50, IGP20, or IAP20 Transmitters	-B
One Seal System, Low Side, IDP10/IDP10S, IDP25, or IDP50 Transmitters	-C
One Seal System, IGP10/IGP10S, IGP25, or IAP10/IAP10S Transmitters	-D
Diaphragm Size	
2.4 in (Typical for IGP10/IGP10S, IGP25, and IAP10/IAP10S)	2
2.9 in (Typical for IDP10/IDP10S, IDP25, IDP50, and IGP20)	3
4.1 in (Recommended for minimized temperature effect)	4
Process Connector	
½ in Raised Face Flange	A
¾ in Raised Face Flange	B
1 in Raised Face Flange	1
1½ in Raised Face Flange	C
2 in Raised Face Flange	2
3 in Raised Face Flange	3
Flange Rating	
ANSI Class 150	1
ANSI Class 300	2
ANSI Class 600	3
ANSI Class 1500 - Not available with Diaphragm Size Code 4 (4.1 in)	4
Lower Housing Material (Process Wetted) (k)	
316L SS	S
Nickel alloy (equivalent to Hastelloy C®-276)	C
Tantalum Plate (h) (c)	T
Titanium Grade 4	E
Inconel 600	L
Monel 400	M
Nickel 200	N
Polyvinyl Chloride (PVC) - requires selection of Gasket Code T (Teflon) (b) (j)	P
Diaphragm Material	
316L SS	S
Nickel alloy (equivalent to Hastelloy C®-276)	C
Tantalum	T
Titanium Grade 4 (maximum process temperature 149°C (300°F))	E
Inconel 600	L
Monel 400	M
Nickel 200	N
316L SS, Teflon Coated	F
Nickel alloy (equivalent to Hastelloy C®-276), Gold Plated	G
Flange Ring/Upper Housing Material (Not Process Wetted) (i)	
Carbon Steel/316L SS (g)	K
316L SS/316L SS	S
Instrument Connection	
Capillary welded to both the transmitter and seal.	1
Gasket (j)	
Klinger C-4401	S
Teflon; Standard with Nonmetallic Lower Housings	T

MODEL CODE - PSFAR PRESSURE SEALS (CONTINUED)

Description	Model		
Buna N	B		
Viton	V		
Grafoil	G		
CGR-2750	W		
Gylon 3510	X		
Kalrez	Y		
Flushing Connector			
None	A		
¼ NPT	B		
Dual ¼ NPT	C		
½ NPT	D		
Dual ½ NPT	E		
Bolting			
None - See Note (c)	0		
Carbon Steel (Standard Construction) (c)	C		
High Strength 300 Series Stainless (for ANSI Class 600 and Higher)	H		
300 Series SS (for ANSI Class 300 and Lower) (c)	S		
Fill Fluid - Pressure Seal and Capillary			
Fill Fluid	Temperature Limits		
	°C	°F	
DC200, 10 cSt Silicone	-40 and +204	-40 and +400	1
FC77, Inert (d)	-59 and +82	-75 and +180	2
DC200, 3 cSt Silicone	-40 and +149	-40 and +300	3
DC704, Silicone	0 and 304	32 and 580	4
Neobee M20	-18 and +204	0 and 400	5
Halocarbon 4.2	-45 and +160	-49 and +320	6
Syltherm XLT	-73 and +149	-100 and +300	7
Capillary Internal Diameter			
0.027 in; Not Available with DC704 Silicone, Fill Fluid Code 4			3
0.040 in			4
0.062 in; Not Available with IAP10/IAP10S, IGP10/IGP10S, or IGP25 Transmitters			6
Capillary Length and Type			
1.5 m (5 ft) 300 Series SS Flexible Armor			A
3.0 m (10 ft) 300 Series SS Flexible Armor			B
4.5 m (15 ft) 300 Series SS Flexible Armor			C
6.0 m (20 ft) 300 Series SS Flexible Armor			D
7.5 m (25 ft) 300 Series SS Flexible Armor			E
9.0 m (30 ft) 300 Series SS Flexible Armor			F
10.5 m (35 ft) 300 Series SS Flexible Armor			S
12.0 m (40 ft) 300 Series SS Flexible Armor (f)			T
13.5 m (45 ft) 300 Series SS Flexible Armor (f)			U
15.0 m (50 ft) 300 Series SS Flexible Armor (f)			V
1.5 m (5 ft) 300 Series SS Flexible Armor, Protective Coat			G
3.0 m (10 ft) 300 Series SS Flexible Armor, Protective Coat			H
4.5 m (15 ft) 300 Series SS Flexible Armor, Protective Coat			J
6.0 m (20 ft) 300 Series SS Flexible Armor, Protective Coat			K
7.5 m (25 ft) 300 Series SS Flexible Armor, Protective Coat			L
9.0 m (30 ft) 300 Series SS Flexible Armor, Protective Coat			M
10.5 m (35 ft) 300 Series SS Flexible Armor, Protective Coat			N
12.0 m (40 ft) 300 Series SS Flexible Armor, Protective Coat (f)			P
13.5 m (45 ft) 300 Series SS Flexible Armor, Protective Coat (f)			Q
15.0 m (50 ft) 300 Series SS Flexible Armor, Protective Coat (f)			R

- (a) When Seal Orientation Code A is specified, then indicate that two identically model numbered seals are required.
- (b) The maximum working pressure with the PVC lower housings is 150 psig, regardless of the higher allowable flange pressure ratings.
- (c) Bolting Codes 0 (None), C, and S are to be specified per the table below:
- (d) Inert FC77 (Flourinert) fill is not available with IAP10/IAP10S or IAP20 transmitters. Use Halocarbon 4.2 fill.
- (e) Requires silicone fill in transmitter’s sensor.
- (f) For model codes PSFAR-.2.....6, the maximum capillary length is 35 ft.
- (g) Only available with Bolting Code 0.
- (h) Not available with a Flushing Connector
- (i) Other materials of construction are available. Contact Invensys for availability.
- (j) Non-metallic Lower Housings require Teflon gasket, and are not available with a Flushing Connector.
- (k) Additional lower housing materials are available. Contact Invensys for availability.

PSFAR AND PSFAD SERIES, FLANGED CONNECTION, REMOTE MOUNT OR DIRECT CONNECT PRESSURE SEALS WITH RECESSED DIAPHRAGM

Allowable Bolting Selections			
Bolting Code	Diaphragm Size Code	Process Connector Code	Flange Rating Code
0 (None)	2	1, C, 2, 3	1, 2, 3, 4
	3	C, 2, 3	1, 2, 3, 4
	4	2	2, 3, 4
	4	3	1, 2, 3, 4
C, S, or H	2	A, B	1, 2, 3, 4
	3	A, B, 1	1, 2, 3, 4
	4	2	1
	4	A, B, C, 1	1, 2, 3, 4

MODEL CODE - PSFAD PRESSURE SEALS

Description	Model
Flanged, Direct Connect, Recessed Diaphragm Seals for use with IGP10/IGP10S, IGP25, and IAP10/IAP10S Transmitters.	PSFAD
Diaphragm Size	
2.4 in	2
2.9 in (for reduced temperature effect at small spans)	3
4.1 in (for optimal temperature performance)	4
Process Connector	
½ in Raised Face Flange	A
¾ in Raised Face Flange	B
1 in Raised Face Flange	1
1½ in Raised Face Flange	C
2 in Raised Face Flange	2
3 in Raised Face Flange	3
Flange Rating	
ANSI Class 150	1
ANSI Class 300	2
ANSI Class 600	3
ANSI Class 1500 - Not available with Diaphragm Size Code 4 (4.1 in)	4
Lower Housing Material (Process Wetted) (h)	
316L SS	S
Nickel alloy (equivalent to Hastelloy C®-276)	C
Tantalum Plate (e) (f)	T
Titanium Grade 4	E
Inconel 600	L
Monel 400	M
Nickel 200	N
Polyvinyl Chloride (PVC) - requires selection of Gasket Code T (Teflon) (a) (g)	P
Diaphragm Material	
316L SS	S
Nickel alloy (equivalent to Hastelloy C®-276)	C
Tantalum; standard with Lower Housing Code T (Tantalum Plate)	T
Titanium Grade 4 - requires selection of Upper Housing Material Code T (Titanium)	E
Inconel 600	L
Monel 400 - requires selection of Upper Housing Code M (Monel)	M
Nickel 200	N
Flange Ring/Upper Housing Material (Not Process Wetted) (f)	
Carbon Steel/316L SS (d)	K
316L SS/316L SS	S
Instrument Connection	
½ NPT	2
Gasket (f)	
Klinger C-4401	S
Teflon; Standard with Non-metallic Lower Housings	T
Buna N	B
Viton	V
Grafoil	G
CGR-2750	W
Gylon 3510	X
Kalrez	Y
Flushing Connector	
None	A

MODEL CODE - PSFAD PRESSURE SEALS (CONTINUED)

Description	Model
¼ NPT	B
Dual ¼ NPT	C
½ NPT	D
Dual ½ NPT	E
Bolting – Used with Stud Mounting Configuration (See DIMENSIONS Section)	
None – See Note (b)	O
Carbon Steel (Standard Construction) (b)	C
300 Series SS (for ANSI Class 300 and Lower) (b)	S
High Strength 300 Series Stainless (for ANSI Class 600 and Higher)	H
Fill Fluid - Pressure Seal and Capillary	
Fill Fluid	Temperature Limits
	°C °F
DC200, 10 cSt Silicone	-40 and +204 -40 and +400
FC77, Inert (c)	-59 and +82 -75 and +180
DC200, 3 cSt Silicone	-40 and +149 -40 and +300
DC704, Silicone	0 and 304 32 and 580
Neobee M20	-18 and +204 0 and 400
Halocarbon 4.2	-45 and +160 -49 and +320
Syltherm XLT	-73 and +149 -100 and +300
	1
	2
	3
	4
	5
	6
	7

- (a) The maximum working pressure with the PVC lower housings is 150 psig, regardless of the higher allowable flange pressure ratings.
- (b) Bolting Codes 0 (None), C, and S are to be specified per the table on the next page.
- (c) Inert FC77 (Flourinert) fill is not available with IAP10/IAP10S transmitters. Use Halocarbon 4.2 fill.
- (d) Only available with Bolting Code 0.
- (e) Not available with a Flushing Connector.
- (f) Other materials of construction are available. Contact Invensys for availability.
- (g) Non-metallic Lower Housings require Teflon gasket and are not available with a Flushing Connector.
- (h) Additional Lower Housing materials are available. Contact Invensys for availability.

Allowable Bolting Selections			
Bolting Code	Diaphragm Size Code	Process Connector Code	Flange Rating Code
0 (None)	2	1, C, 2, 3	1, 2, 3, 4
	3	C, 2, 3	1, 2, 3, 4
	4	2	2, 3, 4
	4	3	1, 2, 3, 4
C, S, or H	2	A, B	1, 2, 3, 4
	3	A, B, 1	1, 2, 3, 4
	4	2	1
	4	A, B, C, 1	1, 2, 3, 4

ORDERING INSTRUCTIONS – MODEL PSFAR

1. Applicable Transmitter Model Number (See Transmitter PSS)

e.g., IGP10-DS3D1F-L1C1W

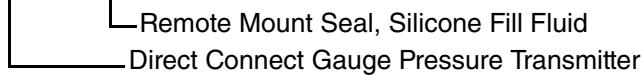

2. Pressure Seal Model Number from this PSS

e.g., PSFAR-D232SSS1SBC14D

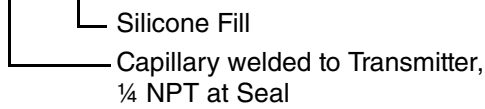

ORDERING INSTRUCTIONS – MODEL PSFAD

1. Applicable Transmitter Model Number (See Transmitter PSS)

e.g., IGP10-D2D1F-L1C1W

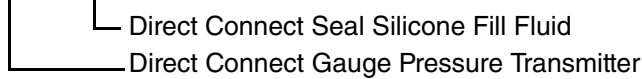

2. Pressure Seal Model Number from this PSS

e.g., PSFAD-232SSS2SBC1

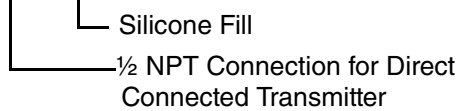

**PSFFR AND PSFFD SERIES, FLANGED CONNECTION, REMOTE MOUNT OR DIRECT
CONNECT PRESSURE SEALS WITH FLUSH DIAPHRAGMS**

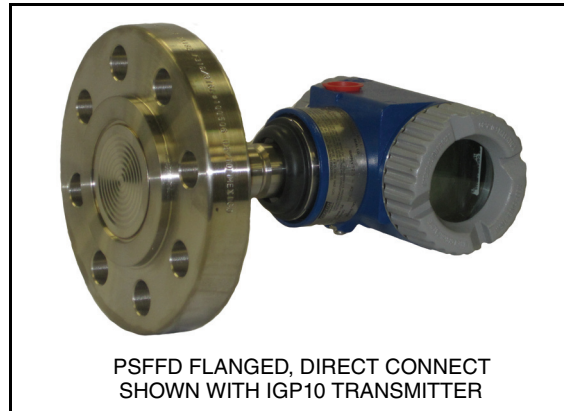
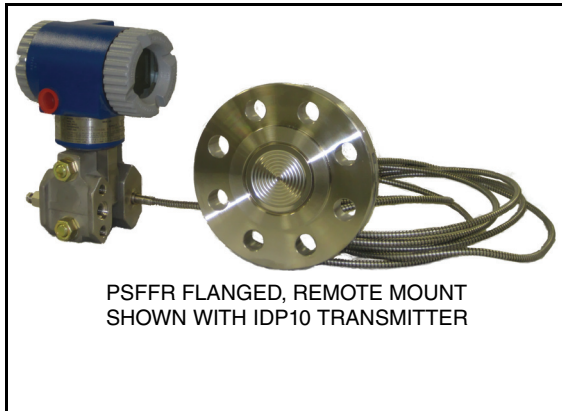

The PSFFR, with remote mount, flanged flush mounted diaphragm seals, is used with the IAP10, IAP10S, IAP20, IDP10, IDP10S, IDP25, IDP50, IGP10, IGP10S, and IGP20 transmitters. The PSFFR transmitter can be mounted in a remote location with interconnecting capillary lengths up to 15 m (50 ft). The PSFFD, with direct connect, flanged flush mounted diaphragm seals, is used with the IAP10, IAP10S, IGP10, IGP10S, and IGP25 transmitters. These transmitter-seal systems provide precise, reliable measurements. For transmitter specifications, refer to the applicable transmitter PSS in Table 7 or 8 at the end of this document.

Process Pressure-Temperature Limits - ANSI and DIN Flanges(a)(b)

ANSI(c) Carbon Steel and 316 SS Flanges						
Process Temperature(d)	Pressure Rating in psig - Carbon Steel			Pressure Rating in psig - 316 SS		
	Class 150	Class 300	Class 600	Class 150	Class 300	Class 600
-20 to 100°F	285	740	1480	275	720	1440
200°F	260	680	1360	235	620	1240
300°F	230	655	1310	215	560	1120
400°F	200	635	1265	195	515	1025
500°F	170	605	1205	170	480	955
600°F	140	570	1135	140	450	900
DIN(e) Carbon Steel and 316 SS Flanges						
Process Temperature(d)	Pressure Rating in bar gauge - Carbon Steel		Pressure Rating in bar gauge - 316 SS			
	PN 10/40		PN 10/40			
-10 to +120°C	40		40			
150°C	37.5		36.3			
200°C	35		33.7			
250°C	32		31.8			
300°C	30		29.7			
350°C	27.8		28.5			

- (a) Maximum temperature limit with PSFFD is 400°F (204°C).
- (b) Maximum temperature limit with PSFFR is 580°F (304°C).
- (c) ANSI flanges per ASME/ANSI B16.5 - 2003.
- (d) Flange temperature/pressure ratings only; seal temperature may be lower depending on mounting and fill fluid.
- (e) DIN flanges per EN 1092-1.

Fill Fluid-Pressure Seal and Capillary

Fill Fluid	Temperature Limits
DC200, 10 cSt Silicone	-40 and +204°C (-40 and +400°F)
FC77, Inert	-59 and +82°C (-75 and +180°F)
DC200, 3 cSt Silicone	-40 and +149°C (-40 and +300°F)
DC704, Silicone	0 and 304°C (32 and 580°F)(a)
Neobee M20	-18 and +204°C (0 and 400°F)
Halocarbon 4.2	-45 and +160°C (-49 and +320°F)
Syltherm XLT	-73 and +149°C (-100 and +300°F)

(a) When used with a direct connect PSFFD seal, the temperature limit is reduced to 204°C (400°F).

Ambient Temperature Effect and Response Time

Applicable to remote, capillary connected seals only. See PERFORMANCE DATA at end of this document.

**Approximate Mass of Transmitter and PSFFD Seal with ANSI Flanges
Single Seal – Direct Mount**

ANSI Flange Rating	Approximate Mass in Pounds			
	1½ inch Flange Size	2 inch Flange Size	3 inch Flange Size	4 inch Flange Size
Class 150	15	16	21	29
Class 300	19	19	28	40
Class 600	20	20	32	53

**Approximate Mass of Transmitter and PSFFD Seal with DIN Flanges
Single Seal – Direct Mount**

DIN Flange Rating	Approximate Mass in Kilograms			
	40 mm Flange Size	80 mm Flange Size	80 mm Flange Size	100 mm Flange Size
PN 10/40	8	9	11	15

NOTE

The approximate mass values listed in the tables above are for an IAP10, IAP10S, IGP10, IGP10S, or IGP25 transmitter with an aluminum housing and process connectors. The mass for this transmitter (without capillaries or seals) is 4.2 kg

Process Wetted Materials

DIAPHRAGM

316L SS, nickel alloy (equivalent to Hastelloy C®-276), Tantalum

Seal Orientation

Seal can be on HI or LO side, or both sides depending on transmitter used. See Model Code.

Connection to Transmitter

REMOTE MOUNT (PSFFR ONLY)

Low volume; welded to capillary connection at both the transmitter and seal.

DIRECT MOUNT (PSFAD ONLY)

A ½ NPT internal thread on flange ring/upper housing directly connects to an IAP10/IAP10S, IGP10/IGP10S, or IGP25 transmitter.

**Approximate Mass of Transmitter and PSFFR Seal with ANSI Flanges
Dual Seals each with a 5 ft Capillary**

ANSI Flange Rating	Approximate Mass in Pounds		
	2 inch Flange Size	3 inch Flange Size	4 inch Flange Size
Class 150	24	34	50
Class 300	30	48	72
Class 600	32	56	98

**Approximate Mass of Transmitter and PSFFR Seal with DIN Flanges
Dual Seals each with a 1.5 m Capillary**

DIN Flange Rating	Approximate Mass in Kilograms		
	50 mm Flange Size	80 mm Flange Size	100 mm Flange Size
PN 10/40	14	19	26

(9.2 lb). Therefore, the mass is mostly determined by the capillary and flange configurations selected, and not by the transmitter itself.

Dimensions - Nominal

See figures below and DP 020-356 and DP 020-357.

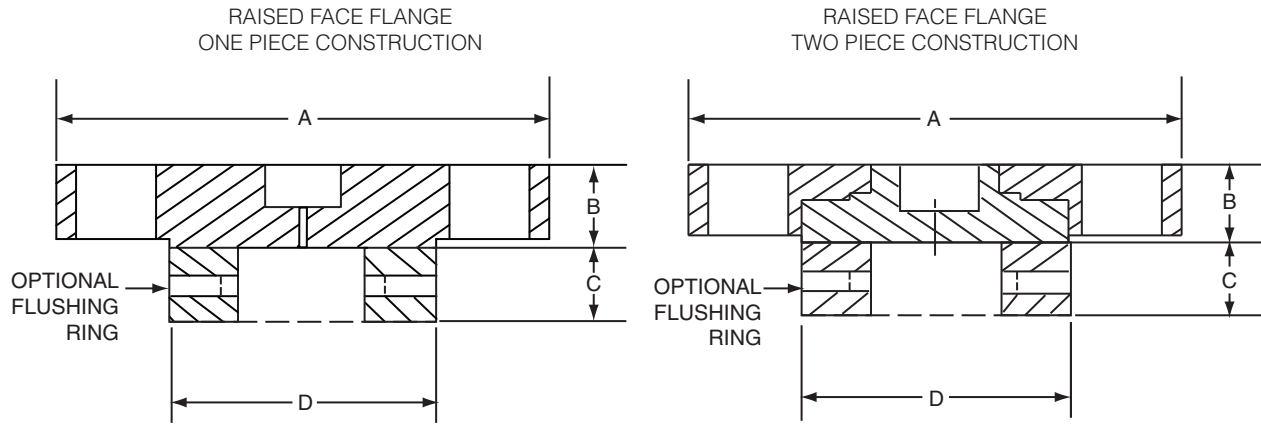

NOTE

See tables below for Dimensions A and B.

One Piece Construction (1)

Two Piece Construction (2)

Dimensions "C" and "D"

ANSI Flange (5)	A	B
1½ in Class 150	5.00	0.69
1½ in Class 300	6.12	0.81
1½ in Class 600	6.12	1.12
2 in Class 150	6.00	0.75
2 in Class 300	6.50	0.88
2 in Class 600	6.50	1.25
3 in Class 150	7.50	0.94
3 in Class 300	8.25	1.12
3 in Class 600	8.25	1.50
4 in Class 150	9.00	0.94
4 in Class 300	10.00	1.25
4 in Class 600	10.75	1.75

ANSI Flange (5)	A	B
1½ in Class 150	5.00	1.12
1½ in Class 300	6.12	1.25
1½ in Class 600	6.12	1.38
2 in Class 150	6.00	1.19
2 in Class 300	6.50	1.32
2 in Class 600	6.50	1.50
3 in Class 150	7.50	1.37
3 in Class 300	8.25	1.15
3 in Class 600	8.25	1.50
4 in Class 150	9.00	1.38
4 in Class 300	10.00	1.69
4 in Class 600	10.75	2.00

ANSI Flange (5)	NPT Flushing Conn.	Dim. "C"	Dim. "D"
1½ in	¼ in	1.00	2.88
	½ in	1.50	3.00
2 in	¼ in	1.00	3.62
	½ in	1.50	3.62
3 in	¼ in	1.00	5.00
	½ in	1.50	5.00
4 in	¼ in	1.00	6.19
	½ in	1.50	6.19

NOTES

1. Applies to "Flange Rating and Material Selections" E, F, G, and H.
2. Applies to "Flange Rating and Material Selections" 1, 2, 3, and A.
3. The dimensions in the tables above are in inches and are for ANSI Class 150, 300, and 600 flanges. Contact Invensys if dimensions for other flange types and sizes are required.
4. In addition to the Raised Face construction, Ring Type Joint flanges are also available.
5. 1½ in Flanges and 1½ inch Flushing Rings only apply to PSFFD.

MODEL CODE - PSFFR PRESSURE SEALS

Description	Model		
Flanged Flush Remote Mount Pressure Seal for use with I/A Series Pressure Transmitters	PSFFR		
Seal Orientation			
Two Seal System, Balanced - Same Seal on both Sides, IDP10/IDP10S, IDP25, or IMV (a)	-A		
One Seal System, High Side, IDP10/IDP10S, IDP25, IGP20, or IAP20 Transmitters	-B		
One Seal System, Low Side, IDP10/IDP10S Transmitter Only	-C		
One Seal System, IGP10 or IDP10/IDP10S Transmitter Only	-D		
Structure Code (Flange Size, Process Wetted Seal Material, and Flange Face)			
Flange Size	Seal Wetted Material	Flange Face	
2 in (50 mm) (c)	316L SS	Raised Face	2S0
2 in (50 mm) (c)	Nickel alloy (equivalent to Hastelloy C®-276)	Raised Face	2C0
2 in (50 mm) (c) (d)	Tantalum	Raised Face	2T0
3 in (80 mm)	316L SS	Raised Face	3S0
3 in (80 mm)	Nickel alloy (equivalent to Hastelloy C®-276)	Raised Face	3C0
3 in (80 mm) (d)	Tantalum	Raised Face	3T0
4 in (100 mm)	316L SS	Raised Face	4S0
4 in (100 mm)	Nickel alloy (equivalent to Hastelloy C®-276)	Raised Face	4C0
4 in (100 mm) (d)	Tantalum	Raised Face	4T0
2 in (50 mm) (c) (d)	316L SS	Ring Type Joint	2SR
2 in (50 mm) (c) (d)	Nickel alloy (equivalent to Hastelloy C®-276)	Ring Type Joint	2CR
3 in (80 mm) (d)	316L SS	Ring Type Joint	3SR
3 in (80 mm) (d)	Nickel alloy (equivalent to Hastelloy C®-276)	Ring Type Joint	3CR
4 in (100 mm) (d)	316L SS	Ring Type Joint	4SR
4 in (100 mm) (d)	Nickel alloy (equivalent to Hastelloy C®-276)	Ring Type Joint	4CR
Flange Rating and Material (Not Process Wetted)			
ANSI Class 150, Carbon Steel			1
ANSI Class 300, Carbon Steel			2
ANSI Class 600, Carbon Steel (b)			3
PN 10/40, Carbon Steel (b)			A
ANSI Class 150, 316 SS			E
ANSI Class 300, 316 SS			F
ANSI Class 600, 316 SS (b)			G
PN 10/40, 316 SS (b)			H
Instrument Connection			
Low Volume, Welded at Seal and Instrument			3
Fill Fluid - Pressure Seal and Capillary			
Fill Fluid	Temperature Limits		
	°C	°F	
DC200, 10 cSt Silicone	-40 and +204	-40 and +400	1
FC77, Inert	-59 and +82	-75 and +180	2
DC200, 3 cSt Silicone	-40 and +149	-40 and +300	3
DC704, Silicone	0 and 304	32 and 580	4
Neobee M20	-18 and +204	0 and 400	5
Halocarbon 4.2	-45 and +160	-49 and +320	6
Syltherm XLT	-73 and +149	-100 and +300	7
Capillary Internal Diameter			
0.027 in; Not Available with DC704 Silicone, Fill Fluid Code 4			3
0.040 in			4
0.062 in (c)			6

MODEL CODE - PSFFR PRESSURE SEALS (CONTINUED)

Description			Model
Capillary Length and Type			
1.5 m (5 ft) 300 Series SS Flexible Armor			A
3.0 m (10 ft) 300 Series SS Flexible Armor			B
4.5 m (15 ft) 300 Series SS Flexible Armor			C
6.0 m (20 ft) 300 Series SS Flexible Armor			D
7.5 m (25 ft) 300 Series SS Flexible Armor			E
9.0 m (30 ft) 300 Series SS Flexible Armor			F
10.5 m (35 ft) 300 Series SS Flexible Armor			S
12.0 m (40 ft) 300 Series SS Flexible Armor (d)			T
13.5 m (45 ft) 300 Series SS Flexible Armor (d)			U
15.0 m (50 ft) 300 Series SS Flexible Armor (d)			V
1.5 m (5 ft) 300 Series SS Flexible Armor, Protective Coat			G
3.0 m (10 ft) 300 Series SS Flexible Armor, Protective Coat			H
4.5 m (15 ft) 300 Series SS Flexible Armor, Protective Coat			J
6.0 m (20 ft) 300 Series SS Flexible Armor, Protective Coat			K
7.5 m (25 ft) 300 Series SS Flexible Armor, Protective Coat			L
9.0 m (30 ft) 300 Series SS Flexible Armor, Protective Coat			M
10.5 m (35 ft) 300 Series SS Flexible Armor, Protective Coat			N
12.0 m (40 ft) 300 Series SS Flexible Armor, Protective Coat (d)			P
13.5 m (45 ft) 300 Series SS Flexible Armor, Protective Coat (d)			Q
15.0 m (50 ft) 300 Series SS Flexible Armor, Protective Coat (d)			R
Optional Selections			
Flushing Rings			
Size	Connection	Material	
2 in (a)	¼ NPT	316L SS	-FA
2 in (a)	¼ NPT	316L SS with NPT Plug	-FB
3 in (b)	¼ NPT	316L SS	-FC
3 in (b)	¼ NPT	316L SS with NPT Plug	-FD
4 in	¼ NPT	316L SS	-HA
4 in	¼ NPT	316L SS with NPT Plug	-HB
2 in (a)	¼ NPT	Nickel alloy (equivalent to Hastelloy C®-276)	-FE
2 in (a)	¼ NPT	Nickel alloy (equivalent to Hastelloy C®-276) with NPT Plug	-FF
3 in (b)	¼ NPT	Nickel alloy (equivalent to Hastelloy C®-276)	-FG
3 in (b)	¼ NPT	Nickel alloy (equivalent to Hastelloy C®-276) with NPT Plug	-FH
4 in	¼ NPT	Nickel alloy (equivalent to Hastelloy C®-276)	-HC
4 in	¼ NPT	Nickel alloy (equivalent to Hastelloy C®-276) with NPT Plug	-HD
2 in (a)	½ NPT	316L SS	-FJ
2 in (a)	½ NPT	316L SS with NPT Plug	-FK
3 in (b)	½ NPT	316L SS	-FL
3 in (b)	½ NPT	316L SS with NPT Plug	-FM
4 in	½ NPT	316L SS	-HE
4 in	½ NPT	316L SS with NPT Plug	-HF
2 in (a)	½ NPT	Nickel alloy (equivalent to Hastelloy C®-276)	-FN
2 in (a)	½ NPT	Nickel alloy (equivalent to Hastelloy C®-276) with NPT Plug	-FP
3 in (b)	½ NPT	Nickel alloy (equivalent to Hastelloy C®-276)	-FQ
3 in (b)	½ NPT	Nickel alloy (equivalent to Hastelloy C®-276) with NPT Plug	-FR
4 in	½ NPT	Nickel alloy (equivalent to Hastelloy C®-276)	-HG
4 in	½ NPT	Nickel alloy (equivalent to Hastelloy C®-276) with NPT Plug	-HH

MODEL CODE - PSFFR PRESSURE SEALS (CONTINUED)

<u>Description</u>			<u>Model</u>
Flushing Rings (Cont.)			
Size	Connection	Material	
2 in (a)	Dual ¼ NPT	316L SS	-FS
2 in (a)	Dual ¼ NPT	316L SS with NPT Plugs	-FT
3 in (b)	Dual ¼ NPT	316L SS	-FU
3 in (b)	Dual ¼ NPT	316L SS with NPT Plugs	-FV
4 in	Dual ¼ NPT	316L SS	-HJ
4 in	Dual ¼ NPT	316L SS with NPT Plugs	-HK
2 in (a)	Dual ¼ NPT	Nickel alloy (equivalent to Hastelloy C®-276)	-FW
2 in (a)	Dual ¼ NPT	Nickel alloy (equivalent to Hastelloy C®-276) with NPT Plugs	-FX
3 in (b)	Dual ¼ NPT	Nickel alloy (equivalent to Hastelloy C®-276)	-FY
3 in (b)	Dual ¼ NPT	Nickel alloy (equivalent to Hastelloy C®-276) with NPT Plugs	-FZ
4 in	Dual ¼ NPT	Nickel alloy (equivalent to Hastelloy C®-276)	-HL
4 in	Dual ¼ NPT	Nickel alloy (equivalent to Hastelloy C®-276) with NPT Plugs	-HM
2 in (a)	Dual ½ NPT	316L SS	-GA
2 in (a)	Dual ½ NPT	316L SS with NPT Plugs	-GB
3 in (b)	Dual ½ NPT	316L SS	-GC
3 in (b)	Dual ½ NPT	316L SS with NPT Plugs	-GD
4 in	Dual ½ NPT	316L SS	-HN
4 in	Dual ½ NPT	316L SS with NPT Plugs	-HP
2 in (a)	Dual ½ NPT	Nickel alloy (equivalent to Hastelloy C®-276)	-GE
2 in (a)	Dual ½ NPT	Nickel alloy (equivalent to Hastelloy C®-276) with NPT Plugs	-GF
3 in (b)	Dual ½ NPT	Nickel alloy (equivalent to Hastelloy C®-276)	-GG
3 in (b)	Dual ½ NPT	Nickel alloy (equivalent to Hastelloy C®-276) with NPT Plugs	-GH
4 in	Dual ½ NPT	Nickel alloy (equivalent to Hastelloy C®-276)	-HQ
4 in	Dual ½ NPT	Nickel alloy (equivalent to Hastelloy C®-276) with NPT Plugs	-HR
Gold Plated Diaphragm (e)			-GP

(a) Restricted to model codes containing: PSFFR-.2..... Specify a quantity of two (2) identical seals when Seal Orientation Code "A" is specified.

(b) Not available with model codes containing PSFFR-.4.....

(c) For model codes PSFFR-.2.....6, the maximum capillary length is 35 ft.

(d) Option -GP is not available with PSFFR-.T or PSFFR-.R.

MODEL CODE - PSFFD PRESSURE SEALS

<u>Description</u>			<u>Model</u>
Flanged Flush Direct Connect Pressure Seal for use with I/A Series Pressure Transmitters			PSFFD
<u>Structure Code (Flange Size, Process Wetted Seal Material, and Flange Face)</u>			
Flange Size	Seal Wetted Material	Flange Face	
1½ in (40 mm)	316L SS	Raised Face	-1S0
1½ in (40 mm)	Nickel alloy (equivalent to Hastelloy C®-276)	Raised Face	-1C0
1½ in (40 mm)	Tantalum	Raised Face	-1T0
2 in (50 mm)	316L SS	Raised Face	-2S0
2 in (50 mm)	Nickel alloy (equivalent to Hastelloy C®-276)	Raised Face	-2C0
2 in (50 mm)	Tantalum	Raised Face	-2T0
3 in (80 mm)	316L SS	Raised Face	-3S0
3 in (80 mm)	Nickel alloy (equivalent to Hastelloy C®-276)	Raised Face	-3C0
3 in (80 mm)	Tantalum	Raised Face	-3T0
4 in (100 mm)	316L SS	Raised Face	-4S0
4 in (100 mm)	Nickel alloy (equivalent to Hastelloy C®-276)	Raised Face	-4C0
4 in (100 mm)	Tantalum	Raised Face	-4T0
1½ in (40 mm)	316L SS	Ring Type Joint	-1SR
1½ in (40 mm)	Nickel alloy (equivalent to Hastelloy C®-276)	Ring Type Joint	-1CR
2 in (50 mm)	316L SS	Ring Type Joint	-2SR
2 in (50 mm)	Nickel alloy (equivalent to Hastelloy C®-276)	Ring Type Joint	-2CR
3 in (80 mm)	316L SS	Ring Type Joint	-3SR
3 in (80 mm)	Nickel alloy (equivalent to Hastelloy C®-276)	Ring Type Joint	-3CR
4 in (100 mm)	316L SS	Ring Type Joint	-4SR
4 in (100 mm)	Nickel alloy (equivalent to Hastelloy C®-276)	Ring Type Joint	-4CR
<u>Flange Rating and Material (Not Process Wetted)</u>			
ANSI Class 150, Carbon Steel			1
ANSI Class 300, Carbon Steel			2
ANSI Class 600, Carbon Steel (f)			3
PN 10/40, Carbon Steel (f)			A
ANSI Class 150, 316 SS			E
ANSI Class 300, 316 SS			F
ANSI Class 600, 316 SS (f)			G
PN 10/40, 316 SS (f)			H
<u>Instrument Connection</u>			
½ NPT			2
<u>Fill Fluid - Pressure Seal</u>			
Fill Fluid	Temperature Limits		
	°C	°F	
DC200, 10 cSt Silicone	-40 and +204	-40 and +400	1
FC77, Inert	-59 and +82	-75 and +180	2
DC200, 3 cSt Silicone	-40 and +149	-40 and +300	3
DC704, Silicone	0 and 304	32 and 580	4
Neobee M20	-18 and +204	0 and 400	5
Halocarbon 4.2	-45 and +160	-49 and +320	6
Syltherm XLT	-73 and +149	-100 and +300	7

MODEL CODE - PSFFD PRESSURE SEALS (CONTINUED)

Description			Model
Optional Selections			
Flushing Rings			
Size	Connection	Material	
1½ in (a)	¼ NPT	316L SS	-EA
1½ in (a)	¼ NPT	316L SS with NPT Plug	-EB
2 in (b)	¼ NPT	316L SS	-FA
2 in (b)	¼ NPT	316L SS with NPT Plug	-FB
3 in (c)	¼ NPT	316L SS	-FC
3 in (c)	¼ NPT	316L SS with NPT Plug	-FD
4 in (d)	¼ NPT	316L SS	-HA
4 in (d)	¼ NPT	316L SS with NPT Plug	-HB
1½ in (a)	¼ NPT	Nickel alloy (equivalent to Hastelloy C®-276)	-EC
1½ in (a)	¼ NPT	Nickel alloy (equivalent to Hastelloy C®-276) with NPT Plug	-ED
2 in (b)	¼ NPT	Nickel alloy (equivalent to Hastelloy C®-276)	-FE
2 in (b)	¼ NPT	Nickel alloy (equivalent to Hastelloy C®-276) with NPT Plug	-FF
3 in (c)	¼ NPT	Nickel alloy (equivalent to Hastelloy C®-276)	-FG
3 in (c)	¼ NPT	Nickel alloy (equivalent to Hastelloy C®-276) with NPT Plug	-FH
4 in (d)	¼ NPT	Nickel alloy (equivalent to Hastelloy C®-276)	-HC
4 in (d)	¼ NPT	Nickel alloy (equivalent to Hastelloy C®-276) with NPT Plug	-HD
1½ in (a)	½ NPT	316L SS	-EE
1½ in (a)	½ NPT	316L SS with NPT Plug	-EF
2 in (b)	½ NPT	316L SS	-FJ
2 in (b)	½ NPT	316L SS with NPT Plug	-FK
3 in (c)	½ NPT	316L SS	-FL
3 in (c)	½ NPT	316L SS with NPT Plug	-FM
4 in (d)	½ NPT	316L SS	-HE
4 in (d)	½ NPT	316L SS with NPT Plug	-HF
1½ in (a)	½ NPT	Nickel alloy (equivalent to Hastelloy C®-276)	-EG
1½ in (a)	½ NPT	Nickel alloy (equivalent to Hastelloy C®-276) with NPT Plug	-EH
2 in (b)	½ NPT	Nickel alloy (equivalent to Hastelloy C®-276)	-FN
2 in (b)	½ NPT	Nickel alloy (equivalent to Hastelloy C®-276) with NPT Plug	-FP
3 in (c)	½ NPT	Nickel alloy (equivalent to Hastelloy C®-276)	-FQ
3 in (c)	½ NPT	Nickel alloy (equivalent to Hastelloy C®-276) with NPT Plug	-FR
4 in (d)	½ NPT	Nickel alloy (equivalent to Hastelloy C®-276)	-HG
4 in (d)	½ NPT	Nickel alloy (equivalent to Hastelloy C®-276) with NPT Plug	-HH
1½ in (a)	Dual ¼ NPT	316L SS	-EJ
1½ in (a)	Dual ¼ NPT	316L SS with NPT Plugs	-EK
2 in (b)	Dual ¼ NPT	316L SS	-FS
2 in (b)	Dual ¼ NPT	316L SS with NPT Plugs	-FT
3 in (c)	Dual ¼ NPT	316L SS	-FU
3 in (c)	Dual ¼ NPT	316L SS with NPT Plugs	-FV
4 in (d)	Dual ¼ NPT	316L SS	-HJ
4 in (d)	Dual ¼ NPT	316L SS with NPT Plugs	-HK
1½ in (a)	Dual ¼ NPT	Nickel alloy (equivalent to Hastelloy C®-276)	-EL
1½ in (a)	Dual ¼ NPT	Nickel alloy (equivalent to Hastelloy C®-276) with NPT Plugs	-EM
2 in (b)	Dual ¼ NPT	Nickel alloy (equivalent to Hastelloy C®-276)	-FW
2 in (b)	Dual ¼ NPT	Nickel alloy (equivalent to Hastelloy C®-276) with NPT Plugs	-FX
3 in (c)	Dual ¼ NPT	Nickel alloy (equivalent to Hastelloy C®-276)	-FY
3 in (c)	Dual ¼ NPT	Nickel alloy (equivalent to Hastelloy C®-276) with NPT Plugs	-FZ
4 in (d)	Dual ¼ NPT	Nickel alloy (equivalent to Hastelloy C®-276)	-HL
4 in (d)	Dual ¼ NPT	Nickel alloy (equivalent to Hastelloy C®-276) with NPT Plugs	-HM

MODEL CODE - PSFFD PRESSURE SEALS (CONTINUED)

Description			Model
Optional Selections (Cont.)			
Flushing Rings (Cont.)			
Size	Connection	Material	
1½ in (a)	Dual ½ NPT	316L SS	-EN
1½ in (a)	Dual ½ NPT	316L SS with NPT Plugs	-EP
2 in (b)	Dual ½ NPT	316L SS	-GA
2 in (b)	Dual ½ NPT	316L SS with NPT Plugs	-GB
3 in (c)	Dual ½ NPT	316L SS	-GC
3 in (c)	Dual ½ NPT	316L SS with NPT Plugs	-GD
4 in (d)	Dual ½ NPT	316L SS	-HN
4 in (d)	Dual ½ NPT	316L SS with NPT Plugs	-HP
1½ in (a)	Dual ½ NPT	Nickel alloy (equivalent to Hastelloy C®-276)	-EQ
1½ in (a)	Dual ½ NPT	Nickel alloy (equivalent to Hastelloy C®-276) with NPT Plugs	-ER
2 in (b)	Dual ½ NPT	Nickel alloy (equivalent to Hastelloy C®-276)	-GE
2 in (b)	Dual ½ NPT	Nickel alloy (equivalent to Hastelloy C®-276)with NPT Plugs	-GF
3 in (c)	Dual ½ NPT	Nickel alloy (equivalent to Hastelloy C®-276)	-GG
3 in (c)	Dual ½ NPT	Nickel alloy (equivalent to Hastelloy C®-276) with NPT Plugs	-GH
4 in (d)	Dual ½ NPT	Nickel alloy (equivalent to Hastelloy C®-276)	-HQ
4 in (d)	Dual ½ NPT	Nickel alloy (equivalent to Hastelloy C®-276) with NPT Plugs	-HR
Gold Plated Diaphragm (e)			-GP

(a) Restricted to model codes containing: PSFFD-.1.....

(b) Restricted to model codes containing: PSFFD-.2.....

(c) Restricted to model codes containing: PSFFD-.3.....

(d) Restricted to model codes containing: PSFFD-.4.....

(e) Option -GP is not available with PSFFD-..T or PSFFD-..R.

(f) Not available with PSFFD-.4.....

ORDERING INSTRUCTIONS – MODEL PSFFR

1. Applicable Transmitter Model Number (See Transmitter PSS)

e.g., IDP10-DS1C01F-X1Z3K1

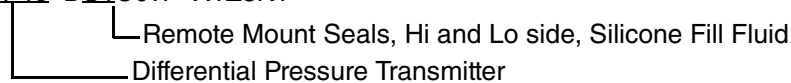

2. Pressure Seal Model Number from this PSS

e.g., PSFFR-A3S0E314B-FC

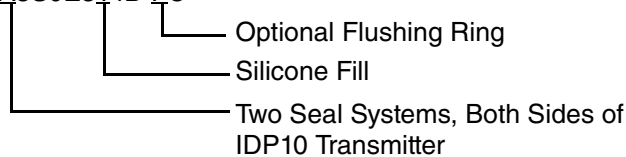

ORDERING INSTRUCTIONS – MODEL PSFFD

1. Applicable Transmitter Model Number (See Transmitter PSS)

e.g., IGP10-DD1F3F

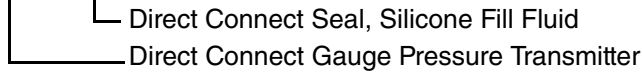

2. Pressure Seal Model Number from this PSS

e.g., PSFFD-1S0321



PSTAR AND PSTAD SERIES, THREADED CONNECTION, REMOTE MOUNT OR DIRECT CONNECT PRESSURE SEALS WITH RECESSED DIAPHRAGM

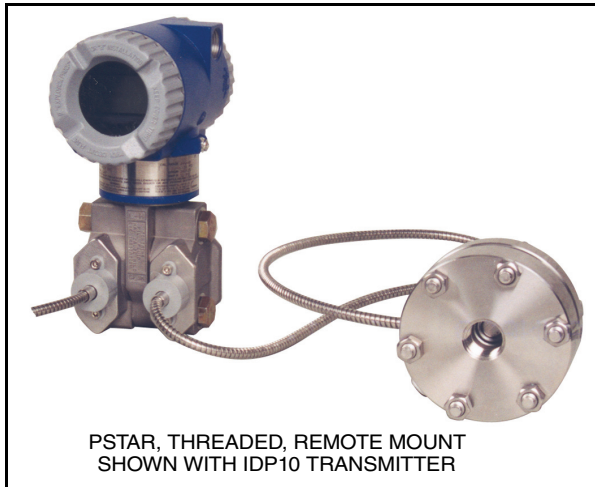

The PSTAR, with remote mount, threaded, recessed diaphragm seals, is used with the IDP10, IDP10S, IDP25, IDP50, IGP20, IAP20, IGP10, IGP10S, IGP25, IAP10, and IAP10S Transmitters. The PSTAR transmitter can be mounted in a remote location with interconnecting capillary lengths up to 15 m (50 ft). The PSTAD, with direct connect, threaded seals, is used with the IGP10, IGP10S, IGP25, IAP10 and IAP10S Transmitters. These transmitter-seal systems are used when a threaded connection to the process is required, along with precise reliable measurements. For transmitter specifications, refer to the applicable transmitter PSS in Table 7 or 8 at the end of this document.

Pressure-Temperature Limits(a)(b)

Process Temperature	Bolting Code S		Bolting Codes C and H	
	Diaphragm Codes 2 and 3	Diaphragm Code 4	Diaphragm Codes 2 and 3	Diaphragm Code 4
-20 to +100°F	1250 psig	750 psig	2500 psig	1500 psig
200°F	1075 psig	645 psig	2150 psig	1290 psig
300°F	975 psig	585 psig	1950 psig	1170 psig
400°F (a)	900 psig	540 psig	1800 psig	1080 psig
500°F	835 psig	500 psig	1670 psig	1000 psig
600°F (b)	760 psig	460 psig	1525 psig	920 psig

(a) The maximum temperature allowed with PSTAD is 400°F (204°C)

(b) The maximum temperature allowed with PSTAR is 580°F (304°C)

Fill Fluid-Pressure Seal and Capillary

Fill Fluid	Temperature Limits
DC200, 10 cSt Silicone	-40 and +204°C (-40 and +400°F)(a)
FC77, Inert	-59 and +82°C (-75 and +180°F)
DC200, 3 cSt Silicone	-40 and +149°C (-40 and +300°F)
DC704, Silicone	0 and 304°C (32 and 580°F)(a)
Neobee M20	-18 and +204°C (0 and 400°F)
Halocarbon 4.2	-45 and +160°C (-49 and +320°F)
Syltherm XLT	-73 and +149°C (-100 and +300°F)

(a) When used with a direct connect PSTAD seal, the temperature limit is reduced to 204°C (400°F).

Seal Orientation

Seal can be on HI or LO side, or both sides depending on transmitter used. See Model Code.

Process Wetted Materials

A wide selection of process wetted materials is available. Materials for lower housings and diaphragms include 316L SS, Nickel alloy (equivalent to Hastelloy C®-276), Inconel 600, Titanium, and others as indicated in the model code selections. Also, lower housings are available in non-metallics such as PVC and Teflon. The standard gasket between the lower housing and the seal is an organic fiber with nitrile binder (Klinger C-4401). Other gasket materials such as Grafoil, Teflon, Viton, and Buna N are also available.

Connection to Transmitter

REMOTE MOUNT (PSTAR ONLY)

Low volume; welded to capillary connection at both the transmitter and seal.

DIRECT CONNECT (PSTAD ONLY)

A ½ NPT internal thread on the flange ring/upper housing directly connects to an IGP10/IGP10S, IGP25, or IAP10/IAP10S transmitter.

Connection to Process

The seal is connected to the process with ¼, ½, ¾, 1, 1½, 1¼, and 2 NPT internal threads located on the lower housing. A transmitter mounting bracket is recommended when using a direct connected transmitter with the ¼ NPT connection.

Ambient Temperature Effect and Response Time

Applicable to remote, capillary connected seals only. See PERFORMANCE DATA further in document.

Dimensions - Nominal

See figure below and DPs 020-347 and 020-348.

PSTAR AND PSTAD 2.4 AND 2.9 in DIAPHRAGMS

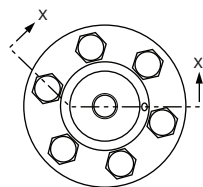
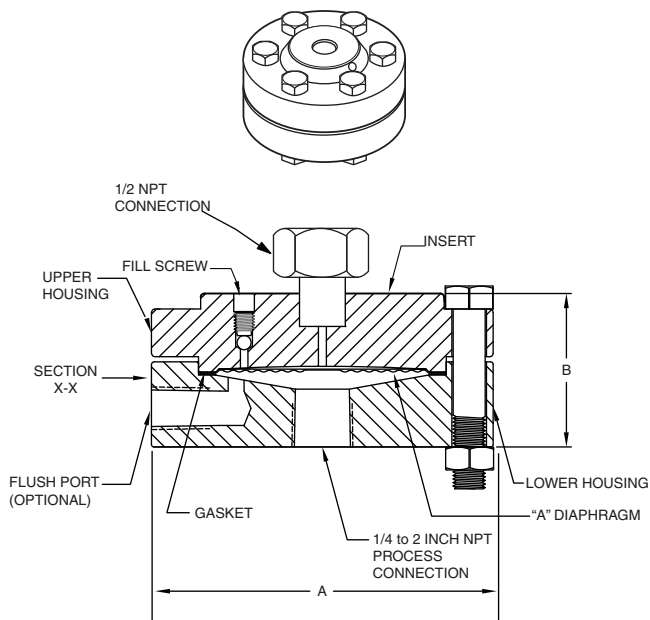

NOTE

Refer to next page for Dimensions A and B.

PSTAR ONLY 4.1 in DIAPHRAGM

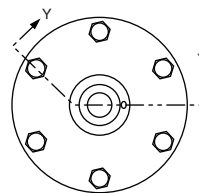
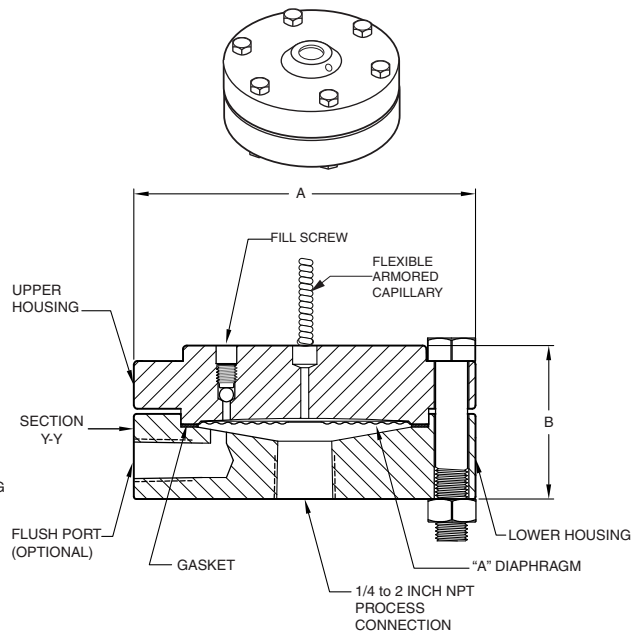

NOTE

WHEN A DIRECT CONNECTED TRANSMITTER IS USED WITH A 1/4 NPT PROCESS CONNECTION, IT IS RECOMMENDED THAT A TRANSMITTER MOUNTING BRACKET BE USED.

**PSTAR and PSTAD Dimensions - Inches
2.4 in and 2.9 in Diaphragm Sizes**

Diaphragm Size	Process Connection	Pressure Rating (c)	Dimensions	
			A	B
2.4 in (a)	¼ NPT	2500 psig	3.50	1.56
2.4 in (a)	½ NPT	2500 psig	3.50	2.00
2.4 in (a)	¾ NPT	2500 psig	3.50	2.00
2.4 in (a)	1 NPT	2500 psig	3.50	2.00
2.4 in (a)	1¼ NPT	2500 psig	3.50	2.00
2.4 in (a)	1½ NPT	2500 psig	3.50	2.1
2.9 in (b)	¼ NPT	2500 psig	4.25	2.00
2.9 in (b)	½ NPT	2500 psig	4.25	2.00
2.9 in (b)	¾ NPT	2500 psig	4.25	2.00
2.9 in (b)	1 NPT	2500 psig	4.25	2.00
2.9 in (b)	1¼ NPT	2500 psig	4.25	2.00
2.9 in (b)	1½ NPT	2500 psig	4.25	2.00
2.9 in (b)	2 NPT	2500 psig	4.25	2.1

- (a) 2.4 in diaphragm size used with IGP10/IGP10S, IGP25, and IAP10/IAP10S Transmitters.
- (b) 2.9 in diaphragm size used with IDP10/IDP10S, IDP25, IDP50, IGP20, and IAP20 Transmitters.
- (c) 2500 psig rating is when using carbon steel bolts or stainless steel bolts on the 2.4 inch Diaphragm Size. See adjacent NOTE for the 2.9 and 4.1 inch Diaphragm Sizes.

**PSTAR Only Dimensions - Inches
4.1 in Diaphragm Size**

Diaphragm Size	Process Connection	Pressure Rating (b)	Dimensions	
			A	B
4.1 in (a)	¼ NPT	1500 psig	5.50	2.12
4.1 in (a)	½ NPT	1500 psig	5.50	2.12
4.1 in (a)	¾ NPT	1500 psig	5.50	2.12
4.1 in (a)	1 NPT	1500 psig	5.50	2.12
4.1 in (a)	1¼ NPT	1500 psig	5.50	2.12
4.1 in (a)	1½ NPT	1500 psig	5.50	2.12
4.1 in (a)	2 NPT	1500 psig	5.50	2.12

- (a) Code 4 (4.1 in) diaphragm size used with PSTAR only for optimal temperature performance.
- (b) The 1500 psig rating is when using carbon steel bolts. See NOTE below.

NOTE

The 2500 psig and 1500 psig ratings in the tables are when carbon steel bolts are used. When using 300 Series stainless steel bolts, the pressure ratings are derated to 1250 psig and 750 psig respectively.

MODEL CODE - PSTAR PRESSURE SEALS

Description	Model																
Threaded Connection, Remote Mount, Recessed Diaphragm Seals	PSTAR																
Seal Orientation																	
Two Seal System, Balanced - Identical Seal on both Sides, IDP10/IDP10S, IDP25, or IDP50 Transmitters (a)	-A																
One Seal System, High Side, IDP10/IDP10S, IDP25, IDP50, IGP20, or IAP20 Transmitters	-B																
One Seal System, Low Side, IDP10/IDP10S, IDP25, or IDP50 Transmitters	-C																
One Seal System, IGP10/IGP10S, IGP25, or IAP10/IAP10S Transmitters	-D																
Diaphragm Size																	
2.4 in (Typical for IGP10/IGP10S, IGP25, and IAP10/IAP10S)	2																
2.9 in (Typical for IDP10/IDP10S, IDP25, IDP50, IGP20, and IAP20)	3																
4.1 in (recommended for minimized temperature effect)	4																
Process Connector																	
¼ in NPT, Internally Threaded	1																
½ in NPT, Internally Threaded	2																
¾ in NPT, Internally Threaded	3																
1 in NPT, Internally Threaded	4																
1¼ in NPT, Internally Threaded	A																
1½ in NPT, Internally Threaded	5																
2 in NPT, Internally Threaded (e)	7																
Pressure Rating																	
Pressure Rating at 100°F (38°C) (c)	U																
(See table below)																	
<table border="1"> <thead> <tr> <th>Diaphragm Size</th> <th>Carbon Steel Bolts</th> <th>Stainless Steel Bolts</th> <th>High Strength Stainless Steel Bolts</th> </tr> </thead> <tbody> <tr> <td>2.4 in</td> <td>2500 psig</td> <td>2500 psig</td> <td>2500 psig</td> </tr> <tr> <td>2.9 in</td> <td>2500 psig</td> <td>1250 psig</td> <td>2500 psig</td> </tr> <tr> <td>4.1 in</td> <td>1500 psig</td> <td>750 psig</td> <td>1500 psig</td> </tr> </tbody> </table>	Diaphragm Size	Carbon Steel Bolts	Stainless Steel Bolts	High Strength Stainless Steel Bolts	2.4 in	2500 psig	2500 psig	2500 psig	2.9 in	2500 psig	1250 psig	2500 psig	4.1 in	1500 psig	750 psig	1500 psig	
Diaphragm Size	Carbon Steel Bolts	Stainless Steel Bolts	High Strength Stainless Steel Bolts														
2.4 in	2500 psig	2500 psig	2500 psig														
2.9 in	2500 psig	1250 psig	2500 psig														
4.1 in	1500 psig	750 psig	1500 psig														
Lower Housing Material (Process Wetted)																	
316L SS	S																
Nickel alloy (equivalent to Hastelloy C®-276)	C																
Titanium Grade 4	E																
Inconel 600	L																
Monel 400	M																
Nickel 200	N																
304L SS	U																
Carpenter (Alloy 20)	V																
Nickel alloy (equivalent to Hastelloy® B2)	W																
Nickel alloy (equivalent to Hastelloy® B4)	X																
Inconel 625	Y																
Diaphragm Material																	
316L SS	S																
Nickel alloy (equivalent to Hastelloy C®-276)	C																
Tantalum	T																
Titanium Grade 4	E																
Inconel 600	L																
Monel 400	M																
Nickel 200	N																
Upper Housing Material (b)																	
316L SS	S																

MODEL CODE - PSTAR PRESSURE SEALS

MODEL CODE - PSTAR PRESSURE SEALS (CONTINUED)

Description	Model																																				
Instrument Connection Capillary welded to both the transmitter and seal.	1																																				
Gasket (b) Klinger C-4401 Teflon; Standard with Nonmetallic Lower Housings Buna N Viton Grafoil CGR-2750 Gylon 3510 Kalrez	S T B V G W X Y																																				
Flushing Connector None ¼ NPT Dual ¼ NPT ½ NPT Dual ½ NPT	A B C D E																																				
Bolting (see Pressure Rating Code U) Carbon Steel (Typical selection for 2500 psig Pressure Rating) 300 Series SS (Derated to 1250 psig Pressure Rating) High Strength 300 Series Stainless	C S H																																				
Fill Fluid - Pressure Seal <table border="0" style="width: 100%;"> <thead> <tr> <th style="text-align: left;">Fill Fluid</th> <th colspan="2" style="text-align: center;">Temperature Limits</th> <th></th> </tr> <tr> <th></th> <th style="text-align: center;">°C</th> <th style="text-align: center;">°F</th> <th></th> </tr> </thead> <tbody> <tr> <td>DC200, 10 cSt Silicone</td> <td style="text-align: center;">-40 and +204</td> <td style="text-align: center;">-40 and +400</td> <td style="text-align: center;">1</td> </tr> <tr> <td>FC77, Inert (d)</td> <td style="text-align: center;">-59 and +82</td> <td style="text-align: center;">-75 and +180</td> <td style="text-align: center;">2</td> </tr> <tr> <td>DC200, 3 cSt Silicone</td> <td style="text-align: center;">-40 and +149</td> <td style="text-align: center;">-40 and +300</td> <td style="text-align: center;">3</td> </tr> <tr> <td>DC704, Silicone</td> <td style="text-align: center;">0 and 304</td> <td style="text-align: center;">32 and 580</td> <td style="text-align: center;">4</td> </tr> <tr> <td>Neobee M20</td> <td style="text-align: center;">-18 and +204</td> <td style="text-align: center;">0 and 400</td> <td style="text-align: center;">5</td> </tr> <tr> <td>Halocarbon 4.2</td> <td style="text-align: center;">-45 and +160</td> <td style="text-align: center;">-49 and +320</td> <td style="text-align: center;">6</td> </tr> <tr> <td>Syltherm XLT</td> <td style="text-align: center;">-73 and +149</td> <td style="text-align: center;">-100 and +300</td> <td style="text-align: center;">7</td> </tr> </tbody> </table>	Fill Fluid	Temperature Limits				°C	°F		DC200, 10 cSt Silicone	-40 and +204	-40 and +400	1	FC77, Inert (d)	-59 and +82	-75 and +180	2	DC200, 3 cSt Silicone	-40 and +149	-40 and +300	3	DC704, Silicone	0 and 304	32 and 580	4	Neobee M20	-18 and +204	0 and 400	5	Halocarbon 4.2	-45 and +160	-49 and +320	6	Syltherm XLT	-73 and +149	-100 and +300	7	
Fill Fluid	Temperature Limits																																				
	°C	°F																																			
DC200, 10 cSt Silicone	-40 and +204	-40 and +400	1																																		
FC77, Inert (d)	-59 and +82	-75 and +180	2																																		
DC200, 3 cSt Silicone	-40 and +149	-40 and +300	3																																		
DC704, Silicone	0 and 304	32 and 580	4																																		
Neobee M20	-18 and +204	0 and 400	5																																		
Halocarbon 4.2	-45 and +160	-49 and +320	6																																		
Syltherm XLT	-73 and +149	-100 and +300	7																																		
Capillary Internal Diameter 0.027 in; Not Available with DC704 Silicone, Fill Fluid Code 4 0.040 in 0.062 in (f)	3 4 6																																				
Capillary Length and Type 1.5 m (5 ft) 300 Series SS Flexible Armor 3.0 m (10 ft) 300 Series SS Flexible Armor 4.5 m (15 ft) 300 Series SS Flexible Armor 6.0 m (20 ft) 300 Series SS Flexible Armor 7.5 m (25 ft) 300 Series SS Flexible Armor 9.0 m (30 ft) 300 Series SS Flexible Armor 10.5 m (35 ft) 300 Series SS Flexible Armor (e) 12.0 m (40 ft) 300 Series SS Flexible Armor (e) 13.5 m (45 ft) 300 Series SS Flexible Armor (e) (f) 15.0 m (50 ft) 300 Series SS Flexible Armor (e) (f) 1.5 m (5 ft) 300 Series SS Flexible Armor, Protective Coat 3.0 m (10 ft) 300 Series SS Flexible Armor, Protective Coat 4.5 m (15 ft) 300 Series SS Flexible Armor, Protective Coat 6.0 m (20 ft) 300 Series SS Flexible Armor, Protective Coat 7.5 m (25 ft) 300 Series SS Flexible Armor, Protective Coat 9.0 m (30 ft) 300 Series SS Flexible Armor, Protective Coat	A B C D E F S T U V G H J K L M																																				

MODEL CODE - PSTAR PRESSURE SEALS (CONTINUED)

Description	Model
10.5 m (35 ft) 300 Series SS Flexible Armor, Protective Coat (e)	N
12.0 m (40 ft) 300 Series SS Flexible Armor, Protective Coat (e)	P
13.5 m (45 ft) 300 Series SS Flexible Armor, Protective Coat (e) (f)	Q
15.0 m (50 ft) 300 Series SS Flexible Armor, Protective Coat (e) (f)	R

- (a) When Seal Orientation Code A is specified, then indicate that two identically model numbered seals are required.
- (b) Additional materials are available. Contact Invensys for availability.
- (c) See Pressure-Temperature Limits Table for pressure ratings at temperature above 100°F.
- (d) Inert FC77 (Flourinert) fill is not available with IAP10/IAP10S or IAP20 transmitters. Use Halocarbon 4.2 fill.
- (e) Not available with Diaphragm Size Code 2.
- (f) Not available with Diaphragm Size Code 3 and Capillary ID Code 6.

ORDERING INSTRUCTIONS

1. Applicable Transmitter Model Number (See Transmitter PSS)

e.g., IGP20-DF1C01F-M2C2WT

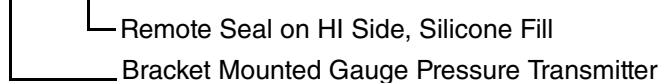

2. Pressure Seal Model Number from this PSS

e.g., PSTAR-B32UOSS1SBS34K

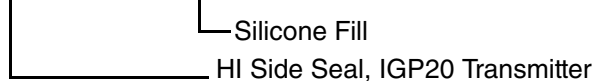

MODEL CODE - PSTAD PRESSURE SEALS

Description	Model
Threaded Connection, Direct Connect, Recessed Diaphragm Seals; for use with IGP10/IGP10S, IGP25, and IAP10/IAP10S Transmitters only.	PSTAD
Diaphragm Size 2.4 in 2.9 in (for reduced temperature effect at small spans) 4.1 in (for optimal temperature performance)	2 3 4
Process Connector ¼ in NPT, Internally Threaded ½ in NPT, Internally Threaded ¾ in NPT, Internally Threaded 1 in NPT, Internally Threaded 1¼ in NPT, Internally Threaded 1½ in NPT, Internally Threaded 2 in NPT, Internally Threaded (d)	1 2 3 4 A 5 7
Pressure Rating 2500 psig (except 1250 psig when SS bolts are used - Bolt Selection Code S); at 100°F (38°C) (a)	U
Lower Housing Material (Process Wetted) 316L SS Nickel alloy (equivalent to Hastelloy C®-276) Titanium Grade 4 Inconel 600 Monel 400 Nickel 200 304L SS Carpenter (Alloy 20) Nickel alloy (equivalent to Hastelloy® B2) Nickel alloy (equivalent to Hastelloy® B4) Inconel 625	S C E L M N U V W X Y
Diaphragm Material 316L SS Nickel alloy (equivalent to Hastelloy C®-276) Tantalum Titanium Grade 2 Inconel 600 Monel 400 Nickel 200	S C T E L M N
Upper Housing Material (not Process Wetted) (c) 316L SS	S
Instrument Connection ½ NPT	2
Gasket (c) Organic Fiber with Nitrile Binder; Standard with Most Metallic Lower Housings Teflon Buna N Viton Grafoil CGR-2750 Gylon 3510 Kalrez	S T B V G W X Y

MODEL CODE - PSTAD PRESSURE SEALS (CONTINUED)

Description	Model
Flushing Connector	
None	A
¼ NPT	B
Dual ¼ NPT	C
½ NPT	D
Dual ½ NPT	E
Bolting	
Carbon Steel (Typical selection for 2500 psig Pressure Rating)	C
300 Series SS (Derated to 1250 psig Pressure Rating)	S
High Strength 300 Series Stainless	H
Fill Fluid - Pressure Seal	
Fill Fluid	Temperature Limits
	°C °F
DC200, 10 cSt Silicone	-40 and +204 -40 and +400
FC77, Inert (b)	-59 and +82 -75 and +180
DC200, 3 cSt Silicone	-40 and +149 -40 and +300
DC704, Silicone	0 and 304 32 and 580
Neobee M20	-18 and +204 0 and 400
Halocarbon 4.2	-45 and +160 -49 and +320
Syltherm XLT	-73 and +149 -100 and +300
	1
	2
	3
	4
	5
	6
	7

- (a) See Pressure-Temperature Limits Table for pressure ratings at temperatures above 100°F. (c) Other materials of construction are available. Contact Invensys for availability.
- (b) Inert FC77 (Flourinert) fill is not available with IAP10/IAP10S transmitters. Use Halocarbon 4.2 fill. (d) Not available with Diaphragm Size Code 2.

ORDERING INSTRUCTIONS

- Applicable Transmitter Model Number (See Transmitter PSS)
 e.g., IGP10-DD1E3F-M2
 └── Direct Connect Seal, Silicone Fill
 └── Direct Connect Gauge Pressure Transmitter
- Pressure Seal Model Number from this PSS
 e.g., PSTAD-21USSS2SBS3
 └── Silicone Fill

PSISR AND PSISD SERIES, IN-LINE SADDLE WELD, REMOTE MOUNT OR DIRECT CONNECT PRESSURE SEALS WITH RECESSED DIAPHRAGMS



The PSISR, with remote mount, in-line welded, recessed diaphragm seals, is used with the IDP10, IDP10S, IDP25, IDP50, IGP20, IAP20, IGP10, IGP10S, IGP25, IAP10, and IAP10S Transmitters. The PSISD, with direct mount, in-line welded seals, is used with the IGP10, IGP10S, IGP25, IAP10, and IAP10S Transmitters. These transmitter-seal systems are used in applications that require a continuous process flow across the diaphragm to insure that pressure sensing is not inhibited by buildup of solids. For transmitter specifications, refer to the applicable transmitter PSS in Table 7 or 8 at the end of this document.

Process Pressure-Temperature Limits

The maximum working pressure is equivalent to a nominal 3- or 4-inch Schedule 40 pipe as defined by ASME/ANSI standards. Do not exceed this pressure rating, nor the temperature limits of the fill fluid selected.

Fill Fluid - Pressure Seal and Capillary

Fill Fluid	Temperature Limits
DC200, 10 cSt Silicone	-40 and +204°C (-40 and +400°F)
FC77, Inert	-59 and +82°C (-75 and +180°F)
DC200, 3 cSt Silicone	-40 and +149°C (-40 and +300°F)
DC704, Silicone	0 and 304°C (32 and 580°F)(a)
Neobee M20	-18 and +204°C (0 and 400°F)
Halocarbon 4.2	-45 and +160°C (-49 and +320°F)
Syltherm XLT	-73 and +149°C (-100 and +300°F)

(a) When used with a direct connect PSISD seal, the temperature limit is reduced to 204°C (400°F).

Process Wetted Materials

A wide selection of process wetted materials is available. Materials for lower housings and diaphragms include 316L SS, Nickel alloy (equivalent to Hastelloy C®-276), Inconel 600, Titanium, and others as indicated in the model code selections.

The standard gasket between the Lower Housing and the Seal is an organic fiber with nitrile binder (Klinger C-4401). Other gasket materials such as Grafoil, Teflon, Viton, and Buna N are also available.

Seal Orientation

Seal can be on HI or LO side, or both sides depending on transmitter. See Model Code.

Connection to Transmitter

REMOTE MOUNT (PSISR ONLY)

Low volume; welded capillary connection at the transmitter and the seal.

DIRECT MOUNT (PSISD ONLY)

A ½ NPT internal thread on upper housing directly connects to an IAP10, IAP10S, IGP10, IGP10S, or IGP25 transmitter.

Connection to Process

The lower housing of the seal is in-line, saddle welded to a nominal 3- or 4-inch (and larger) pipe. After welding the lower section to the pipe, the upper section (which has the diaphragm welded to it) is then bolted to the lower section.

Ambient Temperature Effect and Response Time

Applicable to remote, capillary connected seals only. See PERFORMANCE DATA section further in document.

Dimensions - Nominal

See figures below and DPs 020-349 and 020-350.

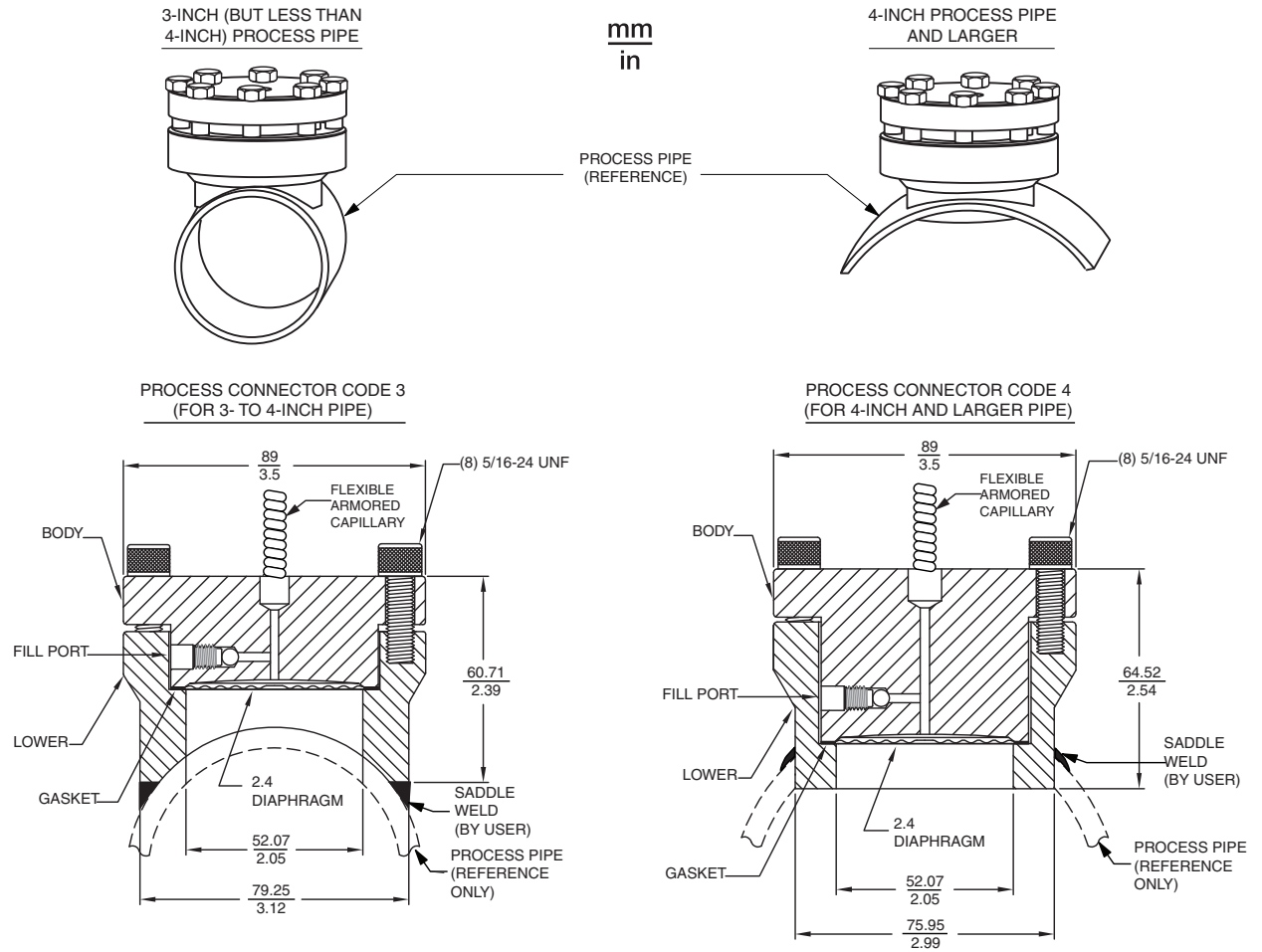

MODEL CODE - PSISR PRESSURE SEALS

Description	Model
In-Line Saddle Weld Connection, Remote Mount, Recessed Diaphragm Seals	PSISR
Seal Orientation	
Two Seal System, Identical Seal on both Sides, IDP10/IDP10S, IDP25, or IDP50 Transmitters (a)	-A
One Seal System, High Side, IDP10/IDP10S, IDP25, IDP50, IGP20, or IAP20 Transmitters	-B
One Seal System, Low Side, IDP10/IDP10S, IDP25, or IDP50 Transmitters	-C
One Seal System, IGP10/IGP10S, IGP25, or IAP10/IAP10S Transmitters	-D
Diaphragm Size	
2.4 in	2
Process Connector	
In-Line, Saddle Weld to Nominal 3-inch Pipe	3
In-Line, Saddle Weld to Nominal 4-inch Pipe	4
Pressure Rating	
Equivalent to a Nominal 3- or 4-inch Schedule 40 Pipe	J
Lower Housing Material (Process Wetted)	
None; Replacement Seal to fit existing Lower Housing (b)	0
316L SS	S
Carbon Steel	K
Nickel alloy (equivalent to Hastelloy C [®] -276)	C
Titanium Grade 4	E
Inconel 600	L
Monel 400	M
Nickel 200	N
Diaphragm Material	
316L SS	S
Nickel alloy (equivalent to Hastelloy C [®] -276)	C
Tantalum	T
Titanium Grade 4	E
Inconel 600	L
Monel 400	M
Nickel 200	N
316L SS, Teflon Coated	F
Nickel alloy (equivalent to Hastelloy C [®] -276), Gold Plated	G
Upper Housing Material (Not Process Wetted) (d)	
316L SS	S
Instrument Connection	
Low Volume; capillary welded at the transmitter and the seal.	1
Gasket	
Standard; Organic Fiber with Nitrile binder (Klinger C-4401)	S
Teflon	T
Buna N	B
Viton	V
Grafoil	G
CGR-2750	W
Gylon 3510	X
Kalrez	Y
Bolting (b)	
Carbon Steel (Standard)	C
300 Series SS (for Class 300 and lower)	S
High Strength 300 Series Stainless	H
None, Replacement Seal	0

MODEL CODE - PSISR PRESSURE SEALS

Description	Model	
Fill Fluid - Pressure Seal		
Fill Fluid	Temperature Limits	
	°C °F	
DC200, 10 cSt Silicone	-40 and +204 -40 and +400	1
FC77, Inert (c)	-59 and +82 -75 and +180	2
DC200, 3 cSt Silicone	-40 and +149 -40 and +300	3
DC704, Silicone	0 and 304 32 and 580	4
Neobee M20	-18 and +204 0 and 400	5
Halocarbon 4.2	-45 and +160 -49 and +320	6
Syltherm XLT	-73 and +149 -100 and +300	7
Capillary Internal Diameter		
0.027 in; Not Available with DC704 Silicone, Fill Fluid Code 4	3	
0.040 in	4	
0.062 in; Not Available with IGP10/IGP10S, IGP25, or IAP10/IAP10S Transmitters	6	
Capillary Length and Type		
1.5 m (5 ft) 300 Series SS Flexible Armor	A	
3.0 m (10 ft) 300 Series SS Flexible Armor	B	
4.5 m (15 ft) 300 Series SS Flexible Armor	C	
6.0 m (20 ft) 300 Series SS Flexible Armor	D	
7.5 m (25 ft) 300 Series SS Flexible Armor	E	
9.0 m (30 ft) 300 Series SS Flexible Armor	F	
1.5 m (5 ft) 300 Series SS Flexible Armor, Protective Coat	G	
3.0 m (10 ft) 300 Series SS Flexible Armor, Protective Coat	H	
4.5 m (15 ft) 300 Series SS Flexible Armor, Protective Coat	J	
6.0 m (20 ft) 300 Series SS Flexible Armor, Protective Coat	K	
7.5 m (25 ft) 300 Series SS Flexible Armor, Protective Coat	L	
9.0 m (30 ft) 300 Series SS Flexible Armor, Protective Coat	M	

- (a) When Seal Orientation Code A is specified, then indicate that two identically model numbered seals are required.
- (b) The PSISR uses a standard eight-bolt pattern. If a custom six-bolt pattern is required, contact Invensys.

- (c) Inert FC77 (Flourinert) fill is not available with IAP10/IAP10S or IAP20 transmitters. Use Halocarbon 4.2 fill.
- (d) Other materials of construction are available. Contact Invensys for availability.

MODEL CODE - PSISD PRESSURE SEALS

Description	Model
In-Line Saddle Weld Connection, Direct Connect, Recessed Diaphragm Seals; for use with IGP10/IGP10S, IGP25 or IAP10/IAP10S Transmitters.	PSISD
<u>Diaphragm Size</u> 2.4 in	2
<u>Process Connector</u> In-Line, Saddle Weld to Nominal 3-inch Pipe In-Line, Saddle Weld to Nominal 4-inch Pipe	3 4
<u>Pressure Rating</u> Equivalent to a Nominal 3- or 4-inch Schedule 40 Pipe	J
<u>Lower Housing Material (Process Wetted)</u> None; Replacement Seal to fit existing Lower Housing 316L SS Carbon Steel Nickel alloy (equivalent to Hastelloy C [®] -276) Titanium Grade 4 Inconel 600 Monel 400 Nickel 200	0 S K C E L M N
<u>Diaphragm Material</u> 316L SS Nickel alloy (equivalent to Hastelloy C [®] -276) Tantalum Titanium Grade 4 Inconel 600 Monel 400 Nickel 200 316L SS, Teflon Coated Nickel alloy (equivalent to Hastelloy C [®] -276), Gold Plated	S C T E L M N F G
<u>Upper Housing Material (c)</u> 316L SS	S
<u>Instrument Connection</u> ½ NPT Welded (d)	2 4
<u>Gasket</u> Standard; Organic Fiber with Nitrile binder (Klinger C-4401) Teflon Buna N Viton Grafoil CGR-2750 Gylon 3510 Kalrez	S T B V G W X Y
<u>Bolting (a)</u> Carbon Steel (Standard) 300 Series SS (for Class 300 and lower) High Strength 300 Series Stainless None, Replacement Seal	C S H 0

MODEL CODE - PSISD PRESSURE SEALS

Description			Model
Fill Fluid - Pressure Seal			
Fill Fluid	Temperature Limits		
	°C	°F	
DC200, 10 cSt Silicone	-40 and +204	-40 and +400	1
FC77, Inert (b)	-59 and +82	-75 and +180	2
DC200, 3 cSt Silicone	-40 and +149	-40 and +300	3
DC704, Silicone	0 and 304	32 and 580	4
Neobee M20	-18 and +204	0 and 400	5
Halocarbon 4.2	-45 and +160	-49 and +320	6
Syltherm XLT	-73 and +149	-100 and +300	7

- (a) The PSISD use a standard eight-bolt pattern. If a custom six-bolt pattern is required, contact Invensys.
- (b) Inert FC77 (Flourinert) fill is not available with IAP10/IAP10S transmitters. Use Halocarbon 4.2 fill.
- (c) Other materials of construction are available. Contact Invensys for availability.

ORDERING INSTRUCTIONS FOR MODEL PSISD

- Applicable Transmitter Model Number (See Transmitter PSS)
 e.g., IGP10-DD1E1F-L1
 └─ Direct Connect Seal, Silicone Fill
 └─ Direct Connect Gauge Pressure Transmitter
- Pressure Seal Model Number from this PSS
 e.g., PSISD-23JSSS2SC1
 └─ Silicone Fill

ORDERING INSTRUCTIONS FOR MODEL PSISR

- Applicable Transmitter Model Number (See Transmitter PSS)
 e.g., IDP10-DS1CO1F-M2L1W
 └─ Remote Seals on HI and LO Sides, Silicone Fill in Sensor
- Pressure Seal Model Number from this PSS
 e.g., PSISR-A23JSSS1SC14M (Quantity of 2 Required)
 └─ Silicone Fill
 └─ Two Seal System, IDP10 Transmitter

PSSCR SERIES SANITARY, TRI-CLAMP, REMOTE MOUNT PRESSURE SEALS WITH
FLUSH DIAPHRAGM



PSSCR, SANITARY, REMOTE MOUNT
SHOWN WITH IGP10 TRANSMITTER

The PSSCR Sanitary Series with remote mount, flush diaphragm seals are used with the IDP10, IDP10S, IDP25, IDP50, IGP20, IAP20, IGP10, IGP10S, IGP25, IAP10, and IAP10S Series Pressure Transmitters. These sanitary seals meet 3-A Sanitary Standards. The seal surface finish can be either 32 Ra or 15 Ra, as selected. They attach to the process connection and are secured with a Tri-Clamp type connector. Refer to the applicable transmitter PSS in Table 7 or 8 at the end of this document.

Process Pressure-Temperature Limits

The maximum working pressure of the seal process connection varies with the sanitary clamping device provided by the user. Refer to the Tri-Clamp type connector specifications to determine the pressure-temperature limits of the clamping system that you are using. Do not exceed the Tri-Clamp type connector limits, nor the temperature limits of the seal and capillary fill fluid selected.

Fill Fluid-Pressure Seal and Capillary

Fill Fluid	Temperature Limits
Neobee M20	-18 and +204°C (0 and +400°F)

Seal Surface Finish

The 32 Ra seal surface finish is applicable to most sanitary industry applications. The 15 Ra seal finish is particularly applicable to the Biopharmaceutical and Pharmaceutical industries.

Process Wetted Materials

HOUSING

316L SS

DIAPHRAGM

316L SS or Nickel alloy (equivalent to Hastelloy C®-276)

GASKET (O-RING)

Provided by user.

Connection to Process

The diaphragm is welded to the process end of the seal, which in turn provides a sanitary process connection to mate with the process connection. The user then provides a Tri-Clamp type connector and gasket to secure the seal to the process. As stated previously, the clamp and fill fluid selected determine the pressure-temperature limits of the seal system.

Connection to Transmitter

Low volume; welded capillary connection at both instrument and seal (some models may have capillary threaded at seals).

Ambient Temperature Effect and Response Time

Applicable to remote, capillary connected seals only. See Performance Data section further in document.

Seal Orientation

Seal can be on HI or LO side, or both sides, depending on transmitter model used.

Dimensions - Nominal

See figures below and DP 020-351.

PSSCR SHOWN WITH IGP10 TRANSMITTER

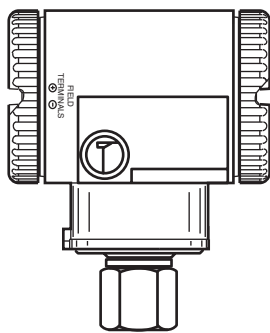

PSSCR SHOWN WITH IGP20 TRANSMITTER

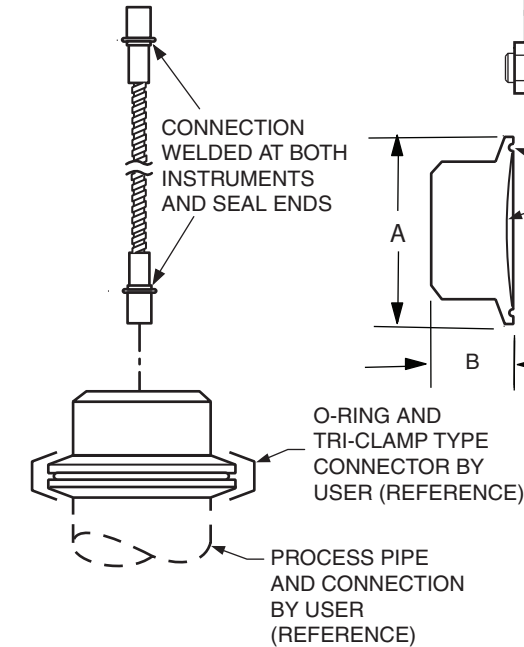
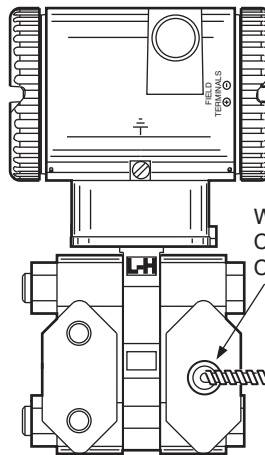

O-RING AND TRI-CLAMP TYPE CONNECTOR BY USER (REFERENCE)

WELDED CAPILLARY CONNECTION

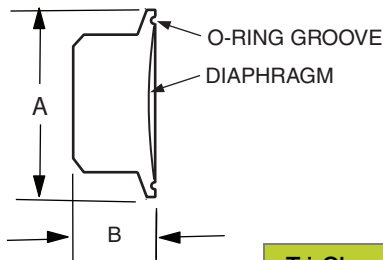

PROCESS PIPE AND CONNECTION BY USER (REFERENCE)

Tri-Clamp Size	Dimension "A"	Dimension "B"
2-inch	2.50 in	1.20 in
3-inch	3.50 in	1.20 in
4-inch	4.35 in	1.20 in

MODEL CODE - PSSCR PRESSURE SEALS

Description	Model
Sanitary Seal, Tri-Clamp Type Connector, Remote Mount with Flush Diaphragm; for use with IDP10/IDP10S, IDP25, IDP50, IGP20, IAP20, IGP10/IGP10S, IGP25, or IAP10/IAP10S Transmitters.	PSSCR
Seal Orientation	
Two Seal System, Identical Seal on both Sides, IDP10/IDP10S, IDP25, IDP50 Transmitters (a)	-A
One Seal System, High Side, IDP10/IDP10S, IDP25, IDP50, IGP20, or IAP20 Transmitters	-B
One Seal System, Low Side, IDP10/IDP10S, IDP25, IDP50 Transmitters	-C
One Seal System, IGP10/IGP10S, IGP25, or IAP10/IAP10S Transmitters	-D
Seal Size	
2-inch Seal for use with Nominal 2-inch pipe	2
3-inch Seal for use with Nominal 3-inch pipe	3
4-inch Seal for use with Nominal 4-inch pipe	4
Process Connector (b)	
Tri-Clamp Type Connector	1
Diaphragm Material	
316L SS; Seal Surface Finish is Ra 32	S
Nickel alloy (equivalent to Hastelloy C®-276); Seal Surface Finish is Ra 32	C
316L SS; Seal Surface Finish is Ra 15	R
Nickel alloy (equivalent to Hastelloy C®-276); Seal Surface Finish is Ra 15	H
Instrument Connection	
Low Volume, capillary welded at both instrument and seal	3
Fill Fluid - Pressure Seal and Capillary	
Neobee M20, -18 and +204°C (0 and +400°F) Temperature Limits (c)	5
Capillary Internal Diameter	
0.040 in	4
Capillary Length and Type	
1.5 m (5 ft) 300 Series SS Flexible Armor, Protective Coat	G
3.0 m (10 ft) 300 Series SS Flexible Armor, Protective Coat	H
4.5 m (15 ft) 300 Series SS Flexible Armor, Protective Coat	J
6.0 m (20 ft) 300 Series SS Flexible Armor, Protective Coat	K
7.5 m (25 ft) 300 Series SS Flexible Armor, Protective Coat	L
9.0 m (30 ft) 300 Series SS Flexible Armor, Protective Coat	M

(a) When Seal Orientation Code A is specified, then indicate that two identically model numbered seals are required.

(b) Tri-Clamp Type Connector and O-ring are provided by the user.

(c) Requires silicone fill in transmitter's sensor.

ORDERING INSTRUCTION FOR MODEL PSSCR

1. Applicable Transmitter Model Number (See Transmitter PSS)

e.g., IGP10-DS3EIF-M1C2W

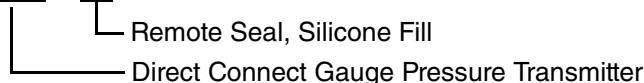

2. Pressure Seal Model Number from this PSS

e.g., PSSCR-D21S354J

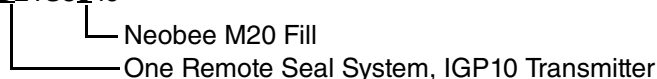

PSSCT SERIES SANITARY, TRI-CLAMP, DIRECT CONNECT PRESSURE SEAL WITH FLUSH DIAPHRAGM

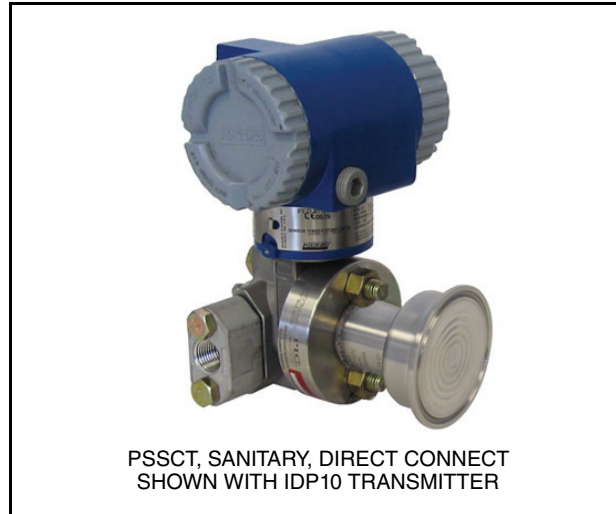

The PSSCT Sanitary Series with direct mount, flush diaphragm seals are used with the IDP10, IDP10S, IDP25, IDP50, or IGP20 Pressure Transmitters. These seals meet 3-A sanitary standards. The seal surface finish can be either 32 Ra or 15 Ra, as specified. They attach to the process connection and are secured with a Tri-Clamp type connector. Refer to the applicable transmitter PSS in Table 7 or 8 at the end of this document.

Seal Surface Finish

The 32 Ra seal surface finish is applicable to most sanitary industry applications. The 15 Ra seal finish is particularly applicable to the Biopharmaceutical and Pharmaceutical industries.

Process Pressure-Temperature Limits

The maximum working pressure of the seal process connection varies with the sanitary clamping device provided by the user. Refer to the Tri-Clamp type connector specifications to determine the pressure-temperature limits of the clamping system that you are using. Do not exceed the Tri-Clamp type connector limits, nor the temperature limits of the seal fill fluid selected.

Fill Fluid - Pressure Seal

Fill Fluid	Temperature Limits
Neobee M20	-18 and +204°C (0 and +400°F)

Process Wetted Materials

HOUSING

316L SS

DIAPHRAGM

316L SS

GASKET (O-RING)

Provided by user.

Seal Orientation

Seal can be on HI side only.

Connection to Transmitter

Seal bolted to high pressure side of transmitter and sealed with a metallic self-energizing O-ring, thus forming an integral transmitter/seal assembly.

Connection to Process

The user provides a Tri-Clamp type connector and gasket to secure the seal to the mating process connector. As stated previously, the clamp size and fill fluid determine the pressure-temperature limits of the seal system.

Approximate Mass

3.5 to 6.5 kg (7.8 to 14.2 lb), depending on transmitter and seal configuration selected.

Ambient Temperature Effect - Transmitter with PSSCT Seal (see tables below)

Total Effect for a 28°C (50°F) Change within Normal Operating Conditions

Transmitter Span Limit Code (a)	Total Ambient Temperature Effect for Transmitters with:	
	Electronics Versions “-D,” “-T,” “-F,” and “-V” (b)	Electronics Version “-A” only (b)
B and C	$\pm(0.03\% \text{ URL} + 0.060\% \text{ Span} + \text{“X”})$	$\pm(0.03\% \text{ URL} + 0.20\% \text{ Span} + \text{“X”})$
D only	$\pm(0.05\% \text{ URL} + 0.045\% \text{ Span} + \text{“X”})$	$\pm(0.05\% \text{ URL} + 0.18\% \text{ Span} + \text{“X”})$
E only	$\pm(0.08\% \text{ URL} + 0.025\% \text{ Span} + \text{“X”})$	$\pm(0.08\% \text{ URL} + 0.15\% \text{ Span} + \text{“X”})$

(a) Pressure seals are not applicable to transmitter Span Limit Code A.

(b) URL, Span, and “X” must be in identical units. See table below for Values of “X”.

Values of “X” for Ambient Temperature Effect Specifications

Pressure Seal Model	Connection Size	Seal Fill Fluid	Value of “X” for Transmitter with a PSSCT Seal	
			mmH ₂ O	inH ₂ O
PSSCT-B21S55	2-in Tri-Clamp Type	Neobee M20	107	4.2
PSSCT-B31S55	3-in Tri-Clamp Type	Neobee M20	51	2.0

Dimensions - Nominal

See figure below and DP 020-355.

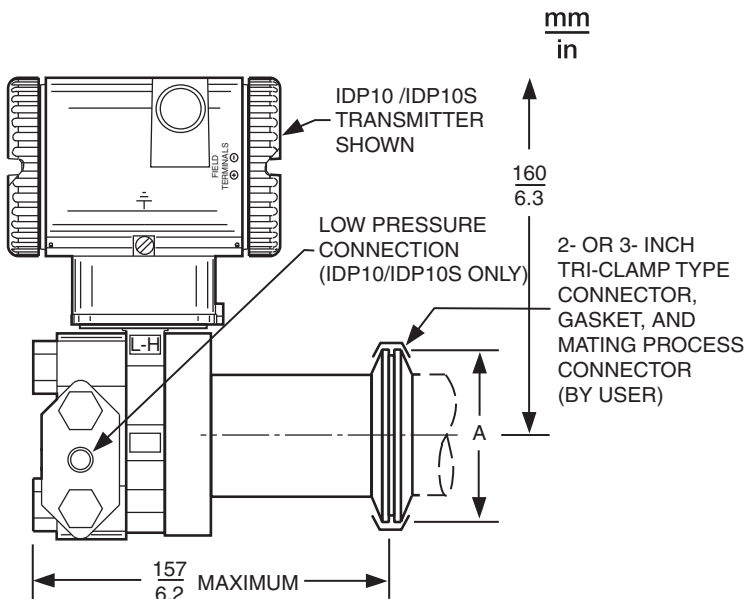

Tri-Clamp Size	Dimension “A”
2-inch	2.50 in
3-inch	3.60 in

MODEL CODE - PSSCT PRESSURE SEALS

Description				Model
Sanitary Flush Diaphragm, Direct Connect Seal; Tri-Clamp Type Connector for Sanitary Piping (a)				PSSCT
<u>Seal Orientation</u> One Seal System, High Side, IDP10/IDP10S , IDP25, IDP50, or IGP20 Transmitters				-B
<u>Structure Code - Connection Size and Type, Diaphragm Material</u>				
Connection Size	Connection Type	Diaphragm Material	Seal Surface Finish	
2 inch	Tri-Clamp	316L SS	32 Ra	21S
3 inch	Tri-Clamp	316L SS	32 Ra	31S
2 inch	Tri-Clamp	316L SS	15 Ra	21R
3 inch	Tri-Clamp	316L SS	15 Ra	31R
<u>Instrument Connection</u> Bolted, with Metal Self-Energizing O-ring				5
<u>Fill Fluid - Pressure Seal</u> Neobee M20, -18 and +204°C (0 and 400°F) Temperature Limits (Requires silicone fill in transmitter's sensor)				5

(a) Tri-Clamp type connector and gasket to be provided by user.

ORDERING INSTRUCTIONS

1. Applicable Transmitter Model Number (see Transmitter PSS)

e.g., IGP20-D12F1C01F

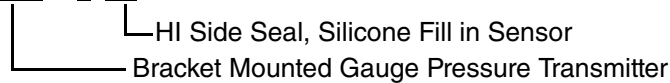

2. Pressure Seal Model Number from this PSS

e.g., PSSCT-B21S55

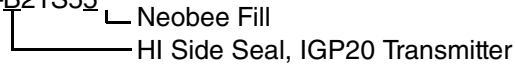

PSSSR AND PSSST SERIES SANITARY, TRI-CLAMP, REMOTE MOUNT OR DIRECT
CONNECT TO STANDARD SPUD OR MINI SPUD



The PSSSR pressure seals are remote mounted, capillary connected, sanitary seals with extended diaphragm for installation on mating tank spuds. They are used with IDP10, IDP10S, IDP25, IDP50, IAP20, IGP20, IAP10, IAP10S, IGP10, IGP10S, and IGP25 transmitters. The PSSST pressure seals are direct-connect extended diaphragm sanitary seals for tank spud installations. They are used with IDP10, IDP10S, IDP25, IDP50, and IGP20 Series transmitters. For transmitter specifications, refer to the applicable transmitter PSS in Table 7 or 8 at the end of this document.

Process Pressure-Temperature Limits

The maximum working pressure of the seal process connection varies with the sanitary clamping device. Refer to Tri-Clamp type standards to determine the pressure-temperature limits of the clamping system that you are using. Do not exceed the Tri-Clamp type connector limits, nor the temperature limits of the seal and capillary fill fluid selected.

Fill Fluid-Pressure Seal and Capillary

Fill Fluid	Temperature Limits(2)
Neobee M20	-18 and +204°C (0 and +400°F)

Process Wetted Materials

HOUSING
316L SS

DIAPHRAGM

316L SS

GASKET (O-RING)(2)

EPDM

Connection to Transmitter

PSSSR

Low volume, metal-to-metal threaded seal at transmitter. Welded at the seal. Capillary has 0.04-in inside diameter.

PSSST

Bolted, with self-energizing O-ring.

(2) PSSSR and PSSST with EPDM O-ring as supplied are limited to 121°C (250°F).

Connection to Process

The seal is connected to the mating tank spud using a Tri-Clamp type connector. The clamp (with gasket) is provided as part of the transmitter/seal assembly. Tank spuds are offered as accessories for users not having an existing spud. As stated previously, the clamp and fill fluid selected determine the pressure-temperature limits of the seal system.

Seal Orientation

Seal can be on HI or LO side, or on both sides as a balanced two-seal system, depending on transmitter model used. See Model Code.

Seal Surface Finish

The seal surface finish can be either 32 Ra or 15 Ra, as specified. The 32 Ra finish is applicable to most sanitary industry applications. The 15 Ra seal finish is particularly applicable to the Biopharmaceutical and Pharmaceutical industries.

Ambient Temperature Effect and Response Time

Applicable to remote, capillary connected seals only. See PERFORMANCE DATA section further in document.

Approximate Mass

Transmitter with Direct Connect Seal

3.5 to 7.5 kg (7.8 to 16.5 lb), depending on configuration selected

Transmitter with Remote Mount Seal

1.5 to 2.8 kg (3.3 to 6.2 lb) for IAP10/IAP10S/IGP10/IGP10S/IGP25 Transmitters, without seal or capillary, depending on configuration selected

3.5 to 5.5 kg (7.8 to 12.1 lb) for IAP20/IGP20/IDP10/IDP10S/IDP25/IDP50 transmitters, without seal or capillary, depending on configuration selected

Ambient Temperature Effect - Transmitter with PSSST Seal (see tables below)

Total Effect for a 28°C (50°F) Change within Normal Operating Conditions

Transmitter Span Limit Code (a)	Total Ambient Temperature Effect for Transmitter with PSSST Seal and:	
	Electronics Versions “-D,” “-T,” “-F”, and “-V” (b)	Electronics Version “-A” only (b)
B and C	$\pm(0.03\% \text{ URL} + 0.060\% \text{ Span} + \text{“X”})$	$\pm(0.03\% \text{ URL} + 0.20\% \text{ Span} + \text{“X”})$
D only	$\pm(0.05\% \text{ URL} + 0.045\% \text{ Span} + \text{“X”})$	$\pm(0.05\% \text{ URL} + 0.18\% \text{ Span} + \text{“X”})$
E only	$\pm(0.08\% \text{ URL} + 0.025\% \text{ Span} + \text{“X”})$	$\pm(0.08\% \text{ URL} + 0.15\% \text{ Span} + \text{“X”})$

(a) Pressure seals are not applicable to transmitter Span Limit Code A.

(b) URL, Span, and “X” must be in identical units. See table below for Values of “X”.

Values of “X” for Ambient Temperature Effect Specifications

Pressure Seal Model	Spud Size	Seal Fill Fluid	Value of “X” for Transmitter with a PSSST Seal	
			mmH ₂ O	inH ₂ O
PSSST-.2S.	2-in Mini	Neobee M20	107	4.2
PSSST-.4S.	4-in Standard	Neobee M20	13	0.5

Dimensions - Nominal

See below. Also see DP 020-353 for PSSSR and DP 020-354 for PSSST.

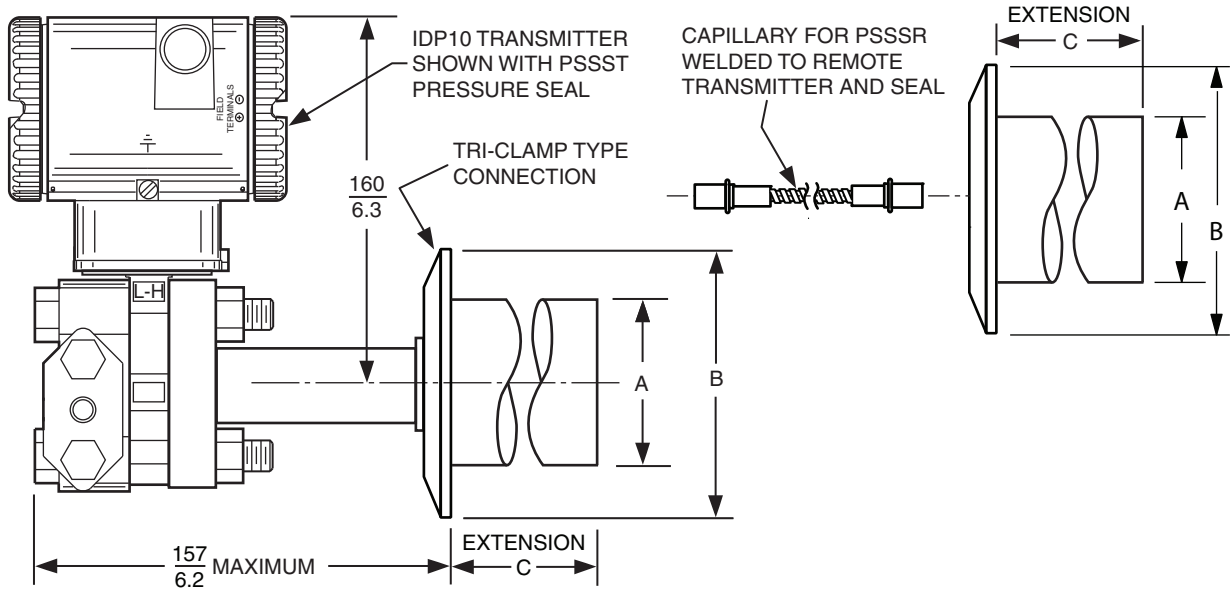

Spud Size(a)	Extension (Nominal)	Model Code	Dimensions(b)		
			A	B	C
4 in	2 in	4S2; 4R2	3.94	5.22	2.03
4 in	6 in	4S6; 4R6	3.94	5.22	6.03
2 in	1½ in	2S2; 2R2	2.13	3.05	1.50
2 in	6 in	2S6; 2R6	2.13	3.05	6.00
2 in	9 in	2S9; 2R9	2.13	3.05	9.00

(a) 2-inch Mini-Spud; 4-inch Standard Spud.

(b) Dimensions are in inches.

MODEL CODE - PSSSR PRESSURE SEALS

MODEL CODE - PSSSR PRESSURE SEALS

Description				Model
Remote Mount, Extended Diaphragm, Sanitary Seal for Spud Mounting; (a) for use with IDP10, IDP10S, IDP25, IDP50, IGP20, IAP20, IAP10, IAP10S, IGP10, and IGP10S Transmitters				PSSSR
Seal Orientation				
Two Seal System, Identical Seals on both sides of IDP10/IDP10S, IDP25, or IDP50 Transmitters (b)				-A
One Seal System, High Side on High side of IDP10/IDP10S, IDP25, IDP50, IGP20, or IAP20 Transmitters				-B
One Seal System, Low Side, IDP10/IDP10S, IDP25, or IDP50 Transmitters				-C
One Seal System, IGP10/IGP10S, IGP25, or IAP10/IAP10S Transmitters				-D
Structure Code - Seal/Tank Spud Size, Diaphragm Material, and Extension Length				
Seal/Tank Spud Size	Diaphragm Material	Extension Length	Seal Surface Finish	
4 in/Standard Spud	316L SS	2 inches	32 Ra	4S2
4 in/Standard Spud	316L SS	6 inches	32 Ra	4S6
2 in/Mini-Spud	316L SS	1½ inch	32 Ra	2S2
2 in/Mini-Spud	316L SS	6 inches	32 Ra	2S6
2 in/Mini-Spud	316L SS	9 inches	32 Ra	2S9
4 in/Standard Spud	316L SS	2 inches	15 Ra	4R2
4 in/Standard Spud	316L SS	6 inches	15 Ra	4R6
2 in/Mini-Spud	316L SS	1½ inch	15 Ra	2R2
2 in/Mini-Spud	316L SS	6 inches	15 Ra	2R6
2 in/Mini-Spud	316L SS	9 inches	15 Ra	2R9
Instrument Connection				
Capillary welded at both transmitter and seal				3
Fill Fluid - Pressure Seal, and Capillary as applicable				
Neobee M20, -18 and +204°C (0 and +400°F) Temperature Limits (c)				5
Capillary Internal Diameter				
0.040 in I.D.				4
Capillary Length and Type				
1.5 m (5 ft) 300 Series SS Flexible Armor, Protective Coat				G
3.0 m (10 ft) 300 Series SS Flexible Armor, Protective Coat				H
4.5 m (15 ft) 300 Series SS Flexible Armor, Protective Coat				J
6.0 m (20 ft) 300 Series SS Flexible Armor, Protective Coat				K
7.5 m (25 ft) 300 Series SS Flexible Armor, Protective Coat				L
9.0 m (30 ft) 300 Series SS Flexible Armor, Protective Coat				M

- (a) Tri-Clamp type connector and O-ring are supplied with transmitter/seal assembly. Tank spuds can be specified separately.
- (b) When Seal Orientation Code A is specified, then indicate that two identically Model Numbered seals are required.
- (c) Requires silicone fill in the transmitter's sensor. See PSSSR Ordering Instructions further in document.

NOTE

See ACCESSORIES Table further in document for tank spud accessories used with the PSSSR Pressure Seals.

MODEL CODE - PSSST PRESSURE SEALS

Description				Model
Direct Connect, Extended Diaphragm, Sanitary Seal for Spud Mounting (a)				PSSST
Seal Orientation				
One Seal System, High Side of IDP10/IDP10S, IDP25, IDP50, or IGP20 Transmitters				-B
Structure Code - Seal/Tank Spud Size, Diaphragm Material, and Extension Length				
Seal/Tank Spud Size	Diaphragm Material	Extension Length	Seal Surface Finish	
4 in/Standard Spud	316L SS	2 inches	32 Ra	4S2
4 in/Standard Spud	316L SS	6 inches	32 Ra	4S6
2 in/Mini-Spud	316L SS	1½ inch	32 Ra	2S2
2 in/Mini-Spud	316L SS	6 inches	32 Ra	2S6
2 in/Mini-Spud	316L SS	9 inches	32 Ra	2S9
4 in/Standard Spud	316L SS	2 inches	15 Ra	4R2
4 in/Standard Spud	316L SS	6 inches	15 Ra	4R6
2 in/Mini-Spud	316L SS	1½ inch	15 Ra	2R2
2 in/Mini-Spud	316L SS	6 inches	15 Ra	2R6
2 in/Mini-Spud	316L SS	9 inches	15 Ra	2R9
Instrument Connection				
PSSST Only - Bolted, with Metal Self-Energizing O-ring				5
Fill Fluid - Pressure Seal, and Capillary as applicable				
Neobee M20, -18 and +204°C (0 and +400°F) Temperature Limits (b)				5

(a) Clamp and O-ring are supplied with transmitter/seal assembly. Tank spuds can be specified separately. See ACCESSORIES Table on next page.

(b) Requires silicone fill in the transmitter's sensor. See PSSST Ordering Instructions on next page.

PSSSR AND PSSST SERIES SANITARY, TRI-CLAMP, REMOTE MOUNT OR DIRECT CONNECT TO STANDARD SPUD OR MINI SPUD

Accessories for use with PSSSR and PSSST Seals

Tank Spud Description	For Use with Structure Code	Part Number	Dimensions in inches		
			A	B	C
Tank Spud - 2 inch Extension	4S2, 4R2	N1212AU	2.10	5.22	5.98
Tank Spud - 6 inch Extension	4S6, 4R6	N1212AV	6.10	5.22	5.98
Tank Spud - 1½ inch Extension	2S2, 2R2	N1212GG	1.50	3.05	3.73
Tank Spud - 6 inch Extension	2S6, 2R6	N1214BP	6.00	3.05	3.73
Tank Spud - 9 inch Extension	2S9, 4R9	N1214BQ	9.00	3.05	3.73

ORDERING INSTRUCTIONS - MODEL PSSSR

1. Applicable Transmitter Model Number (see Transmitter PSS)

e.g., IDP10-DS1B01F-C1

└── Remote Seal, HI and LO Sides, Silicone Fill in Sensor

2. Pressure Seal Model Number from this PSS

e.g., PSSSR-A2S6354H (Quantity of 2 Required)

└── Neobee M20 Fill

└── Two Seal System, both sides of IDP10 Transmitter

3. Accessories - Reference Part Numbers in ACCESSORIES tables on previous page.

ORDERING INSTRUCTIONS - MODEL PSSST

1. Applicable Transmitter Model Number (see Transmitter PSS)

e.g., IGP20-DF1B11F-L1

└── PSSST Seal on High Side, Silicone Fill

└── Bracket Mounted Gauge Pressure Transmitter

2. Pressure Seal Model Number from this PSS

e.g., PSSST-B4S255

└── Neobee M20 Fill

└── One Seal System with IGP20 Transmitter

3. Accessories - Reference Part Numbers in ACCESSORIES tables on previous page.

PERFORMANCE DATA

Ambient Temperature Effect and Response Time

The tables that follow provide ambient temperature effect and response time estimates when remote, capillary connected pressure seals are used. The values in the table were calculated using the following variables, as applicable: fluid type and expansion rate, diaphragm spring rate, length and I.D. of capillary, fluid volume in sensor, seal, and capillary, fluid viscosity, and temperature.

The error values in the temperature effect tables assume that the transmitter, capillary, and single seal are all exposed to the same temperature change. Therefore, when two seals are used, the error from one seal tends to cancel out the error from the second seal. For this reason, the ambient temperature effect tables that follow relate to a single remote seal only. The response time table, however, indicates values when dual seals are used.

The error values in the tables that follow are additive to the transmitter errors except when the transmitter is used with a PSFLT Direct Mount Seal. In this case, the ambient temperature effect is defined for the assembled transmitter-seal system. See previous Model PSFLT, PSSCT, or PSSST sections. Otherwise, refer to the applicable transmitter PSS for “transmitter only” effects with other than the above-mentioned seals.

Ambient Temperature Effect Using DC200, 10 cSt Silicone M20 Fill - Seal and Capillary (316L SS Seal and Diaphragm)

Pressure Seal Model	Process Connector or Diaphragm Size	Internal Diameter of Capillary	Effect per 28°C (50°F) Change Is:			
			for a 1.5 m (5 ft) Capillary Length		for each additional 1.5 m (5 ft) Capillary	
			mmH ₂ O	inH ₂ O	mmH ₂ O	inH ₂ O
PSFPS-□2 PSFFR-□2	2-in ANSI or 50 mm BS/DIN Flange	0.027 in	51	2.0	10	0.4
		0.040 in	61	2.4	20	0.8
		0.062 in	91	3.6	48	1.9
PSFPS-□3 PSFFR-□3	3-in ANSI or 80 mm BS/DIN Flange	0.027 in	13	0.5	3	0.1
		0.040 in	15	0.6	3	0.1
		0.062 in	20	0.8	10	0.4
PSFES-□2	2-in ANSI or 50 mm BS/DIN Flange	0.027 in	160	6.3	36	1.4
		0.040 in	203	8.0	81	3.2
		0.062 in	318	12.5	193	7.6
PSFES-□3	3-in ANSI or 80 mm BS/DIN Flange	0.027 in	69	2.7	10	0.4
		0.040 in	81	3.2	25	1.0
		0.062 in	127	5.0	64	2.5
PSFES-□4	4-in ANSI or 100 mm BS/DIN Flange	0.027 in	13	0.5	3	0.1
		0.040 in	15	0.6	3	0.1
		0.062 in	18	0.7	5	0.2
PSFAR-□2 PSTAR-□2 PSISR -□2	2.4-in Diaphragm	0.027 in	178	7.0	25	1.0
		0.040 in	201	7.9	43	1.7
		0.062 in	267	10.5	109	4.3
PSFAR-□3 PSTAR-□3	2.9-in Diaphragm	0.027 in	51	2	8	0.3
		0.040 in	58	2.3	13	0.5
		0.062 in	76	3	33	1.3
PSFAR-□4 PSTAR-□4	4.1-in Diaphragm	0.027 in	13	0.5	3	0.1
		0.040 in	13	0.5	3	0.1
		0.062 in	15	0.6	5	0.2

Ambient Temperature Effect Using FC77 Inert Fill -Seal and Capillary (316L SS Seal and Diaphragm)

Pressure Seal Model	Process Connector or Diaphragm Size	Internal Diameter of Capillary	Effect per 28°C (50°F) Change Is:			
			for a 1.5 m (5 ft) Capillary Length		for each additional 1.5 m (5 ft) Capillary	
			mmH ₂ O	inH ₂ O	mmH ₂ O	inH ₂ O
PSFPS-□2 PSFFR-□2	2-in ANSI or 50 mm DIN Flange	0.027 in	66	2.6	13	0.5
		0.040 in	81	3.2	28	1.1
		0.062 in	121	4.8	66	2.6
PSFPS-□3 PSFFR-□3	3-in ANSI or 80 mm DIN Flange	0.027 in	15	0.6	3	0.1
		0.040 in	20	0.8	5	0.2
		0.062 in	25	1.0	10	0.4
PSFES-□2	2-in ANSI or 50 mm DIN Flange	0.027 in	216	8.5	43	1.7
		0.040 in	272	10.7	107	4.2
		0.062 in	422	16.6	257	10.1
PSFES-□3	3-in ANSI or 80 mm DIN Flange	0.027 in	91	3.6	17	0.7
		0.040 in	109	4.3	33	1.3
		0.062 in	157	6.2	81	3.2
PSFES-□4	4-in ANSI or 100 mm DIN Flange	0.027 in	18	0.7	3	0.1
		0.040 in	20	0.8	3	0.1
		0.062 in	23	0.9	5	0.2
PSFAR-□2 PSTAR-□2 PSISR -□2	2.4-in Diaphragm	0.027 in	234	9.2	28	1.1
		0.040 in	267	10.5	56	2.2
		0.062 in	353	13.9	168	6.6
PSFAR-□3 PSTAR-□3	2.9-in Diaphragm	0.027 in	69	2.7	8	0.3
		0.040 in	76	3.0	18	0.7
		0.062 in	102	4.0	43	1.7
PSFAR-□4 PSTAR-□4	4.1-in Diaphragm	0.027 in	15	0.6	3	0.1
		0.040 in	18	0.7	3	0.2
		0.062 in	20	0.8	5	0.2

Ambient Temperature Effect Using Dc200, 3 Cst Silicone Fill - Seal and Capillary (316L SS Seal and Diaphragm)

Pressure Seal Model	Process Connector or Diaphragm Size	Internal Diameter of Capillary	Effect per 28°C (50°F) Change Is:			
			for a 1.5 m (5 ft) Capillary Length		for each additional 1.5 m (5 ft) Capillary	
			mmH ₂ O	inH ₂ O	mmH ₂ O	inH ₂ O
PSFPS-□2 PSFFR-□2	2-in ANSI or 50 mm DIN Flange	0.027 in	51	2.0	10	0.4
		0.040 in	64	2.5	23	0.9
		0.062 in	94	3.7	53	2.1
PSFPS-□3 PSFFR-□3	3-in ANSI or 80 mm DIN Flange	0.027 in	13	0.5	3	0.1
		0.040 in	15	0.6	3	0.1
		0.062 in	20	0.8	10	0.4
PSFES-□2	2-in ANSI or 50 mm DIN Flange	0.027 in	168	6.6	38	1.5
		0.040 in	213	8.4	84	3.3
		0.062 in	330	13.0	203	8.0
PSFES-□3	3-in ANSI or 80 mm DIN Flange	0.027 in	70	2.8	12	0.5
		0.040 in	86	3.4	28	1.1
		0.062 in	124	4.9	69	2.7
PSFES-□4	4-in ANSI or 100 mm DIN Flange	0.027 in	13	0.5	3	0.1
		0.040 in	15	0.6	3	0.1
		0.062 in	18	0.7	5	0.2
PSFAR-□2 PSTAR-□2 PSISR -□2	2.4-in Diaphragm	0.027 in	183	7.2	23	0.9
		0.040 in	208	8.2	48	1.9
		0.062 in	277	10.9	91	3.6
PSFAR-□3 PSTAR-□3	2.9-in Diaphragm	0.027 in	53	2.1	5	0.2
		0.040 in	61	2.4	13	0.5
		0.062 in	79	3.1	33	1.3
PSFAR-□4 PSTAR-□4	4.1-in Diaphragm	0.027 in	13	0.5	3	0.1
		0.040 in	13	0.5	3	0.1
		0.062 in	12	0.6	5	0.2

Ambient Temperature Effect Using DC704 Silicone Fill - Seal and Capillary (316L SS Seal and Diaphragm)

Pressure Seal Model	Process Connector or Diaphragm Size	Internal Diameter of Capillary	Effect per 28°C (50°F) Change Is:			
			for a 1.5 m (5 ft) Capillary Length		for each additional 1.5 m (5 ft) Capillary	
			mmH ₂ O	inH ₂ O	mmH ₂ O	inH ₂ O
PSFPS-□2 PSFFR-□2	2-in ANSI or 50 mm DIN Flange	0.027 in	N/A	N/A	N/A	N/A
		0.040 in	51	2/0	18	0.7
		0.062 in	74	2.9	41	1.6
PSFPS-□3 PSFFR-□3	3-in ANSI or 80 mm DIN Flange	0.027 in	N/A	N/A	N/A	N/A
		0.040 in	13	0.5	3	0.1
		0.062 in	15	0.6	8	0.3
PSFES-□2	2-in ANSI or 50 mm DIN Flange	0.027 in	N/A	N/A	N/A	N/A
		0.040 in	165	6.5	66	2.6
		0.062 in	257	10.1	160	6.3
PSFES-□3	3-in ANSI or 80 mm DIN Flange	0.027 in	N/A	N/A	N/A	N/A
		0.040 in	66	2.6	0.8	20
		0.062 in	97	3.8	1.9	48
PSFES-□4	4-in ANSI or 100 mm DIN Flange	0.027 in	N/A	N/A	N/A	N/A
		0.040 in	13	0.5	3	0.1
		0.062 in	13	0.5	5	0.2
PSFAR-□2 PSTAR-□2 PSISR -□2	2.4-in Diaphragm	0.027 in	N/A	N/A	N/A	N/A
		0.040 in	163	6.4	38	1.5
		0.062 in	213	8.4	89	3.5
PSFAR-□3 PSTAR-□3	2.9-in Diaphragm	0.027 in	N/A	N/A	N/A	N/A
		0.040 in	46	1.8	10	0.4
		0.062 in	61	2.4	25	1.0
PSFAR-□4 PSTAR-□4	4.1-in Diaphragm	0.027 in	N/A	N/A	N/A	N/A
		0.040 in	10	0.4	3	0.1
		0.062 in	13	0.5	5	0.2

PERFORMANCE DATA

Ambient Temperature Effect Using Neobee M20 Fill - Seal and Capillary (316L SS Seal and Diaphragm)

Pressure Seal Model	Process Connector or Diaphragm Size	Internal Diameter of Capillary	Effect per 28°C (50°F) Change Is:			
			for a 1.5 m (5 ft) Capillary Length		for each additional 1.5 m (5 ft) Capillary	
			mmH ₂ O	inH ₂ O	mmH ₂ O	inH ₂ O
PSSCR-□2	Tri-Clamp 2-in Diaphragm	0.040 in	174	6.8	69	2.7
PSSCR-□3	Tri-Clamp 3-in Diaphragm	0.040 in	69	2.7	20	0.8
PSSCR-□4	Tri-Clamp 4-in Diaphragm	0.040 in	13	0.5	3	0.1
PSSSR-□2	Tri-Clamp 2-in Diaphragm	0.040 in	174	6.8	69	2.7
PSSSR-□4	Tri-Clamp 4-in Diaphragm	0.040 in	13	0.5	3	0.1

Typical 90% Response Time for an IDP10 Transmitter -for Transmitter Span Limit Codes B and C, and with 316 SS Dual Seals (same Model Number)

Capillary and Seal Fill Fluid	Internal Diameter of Capillary	with 1.5 m (5 ft) Capillary Length at Ambient Temperature of:			9 m (30 ft) Capillary Length at Ambient Temperature of:		
		30°F	80°F	130°F	30°F	80°F	130°F
DC200, 10 cSt	0.027 in	6.99 s	3.48 s	1.95 s	41.9 2s	20.89 s	11.72 s
	0.040 in	1.45 s	0.72 s	0.41 s	8.70 s	1.08 s	0.61 s
	0.062 in	0.25 s	0.13 s	0.07 s	1.51 s	0.75 s	0.42 s
Fluorinert	0.027 in	1.00 s	0.54 s	0.33 s	6.01 s	3.25 s	1.95 s
	0.040 in	0.21 s	0.11 s	0.1 s	1.2 s	0.7 s	0.41 s
	0.062 in	0.04 s	0.02 s	0.01 s	0.22 s	0.11 s	0.07 s
DC200, 3 cSt	0.027 in	1.84 s	1.00 s	0.60 s	11.01 s	5.99 s	3.62 s
	0.040 in	0.38 s	0.21 s	0.13 s	2.29 s	1.24 s	0.75 s
	0.062 in	0.07 s	0.04 s	0.02 s	0.40 s	0.22 s	0.13 s
DC704	0.027 in	N/A	N/A	N/A	N/A	N/A	N/A
	0.040 in	13.64 s	3.09 s	0.90 s	81.86 s	18.56 s	5.41 s
	0.062 in	2.36 s	0.54 s	0.16 s	14.18 s	3.22 s	0.94 s
Neobee M20	0.027 in	8.67 s	3.80 s	1.91 s	41.92 s	22.87 s	11.47 s
	0.040 in	1.80 s	0.79 s	0.40 s	10.80 s	4.73 s	2.38 s
	0.062 in	0.31 s	0.14 s	0.07 s	1.87 s	0.82 s	0.41 s
Halocarbon 4.2	0.027 in	10.17 s	4.10 s	1.93 s	61.01 s	24.61 s	11.58 s
	0.040 in	2.11 s	0.80 s	0.40 s	12.67 s	5.11 s	2.40 s
	0.062 in	0.37 s	0.15 s	0.07 s	2.19 s	0.88 s	0.42 s
Syltherm XLT	0.027 in	0.81 s	0.51 s	0.33 s	4.82 s	2.95 s	1.96 s
	0.040 in	0.17 s	0.10 s	0.07 s	1.00 s	0.61 s	0.41 s
	0.062 in	0.03 s	0.02 s	0.01 s	0.17 s	0.11 s	0.07 s

PRODUCT SPECIFICATION SHEETS (PSSs) FOR I/A SERIES TRANSMITTERS

Table 7. I/A Series Electronic Digital Output Transmitters

Transmitter Model(a)(b)	Version -D FoxCom	Version -T HART	Version -F Fieldbus	Version -M Modbus
IAP10/IAP20 AP Transmitters	PSS 2A-1C13 A	PSS 2A-1C13 B	PSS 2A-1C13 E	Not Applicable
IAP10S AP Transmitters	Not Applicable	PSS 2A-1C13 P	Not Applicable	Not Applicable
IGP10/IGP10S/IGP20 GP Transmitters	PSS 2A-1C13 A	PSS 2A-1C13 B	PSS 2A-1C13 E	Not Applicable
IGP10S GP Transmitters	Not Applicable	PSS 2A-1C13 P	Not Applicable	Not Applicable
IAP10/IAP10S/IGP10/IGP10S Sanitary Industry	PSS 2A-1C13 K	PSS 2A-1C13 K	PSS 2A-1C13 K	Not Applicable
IAP10S/IGP10S Sanitary Industry	Not Applicable	PSS 2A-1C13 P	Not Applicable	Not Applicable
IAP10/IAP10S/IGP10/IGP10S Pulp/Paper Industry	PSS 2A-1C13 L	PSS 2A-1C13 L	PSS 2A-1C13 L	Not Applicable
IAP10S/IGP10S Pulp/Paper Industry	Not Applicable	PSS 2A-1C13 P	Not Applicable	Not Applicable
IGP10 High GP Transmitter	PSS 2A-1C13 F	PSS2A-1C13 F	PSS 2A-1C13 F	Not Applicable
IGP25 MR GP Transmitter	PSS 2A-1C13 G	PSS 2A-1C13 G	PSS 2A-1C13 G	Not Applicable
IGP25 Sanitary Industry	PSS 2A-1C13 M	PSS 2A-1C13 M	PSS 2A-1C13 M	Not Applicable
IGP25 Pulp/Paper Industry	PSS 2A-1C13 N	PSS 2A-1C13 N	PSS 2A-1C13 N	Not Applicable
IGP50 PP GP Transmitter	PSS 2A-1C13 H	PSS 2A-1C13 H	PSS 2A-1C13 H	Not Applicable
IDP10 DP Transmitter	PSS 2A-1C14 A	PSS 2A-1C14 B	PSS 2A-1C13 E	Not Applicable
IDP10S DP Transmitter	Not Applicable	PSS 2A-1C14 M	Not Applicable	Not Applicable
IDP25 MR DP Transmitter	PSS 2A-1C14 K	PSS 2A-1C14 K	PSS 2A-1C14 K	Not Applicable
IDP50 PP DP Transmitter	PSS 2A-1C14 L	PSS 2A-1C14 L	PSS 2A-1C14 L	Not Applicable
IMV25 MV Transmitter	PSS 2A-1C15 B	PSS 2A-1C15 B	PSS 2A-1C15 B	PSS2A-1C15 D
IMV30 MV Transmitter	PSS 2A-1C15 A	PSS 2A-1C15 A	Not Applicable	Not Applicable
IMV31 MV Transmitter	Not Applicable	PSS 2A-1C15 C	Not Applicable	Not Applicable

(a) AP = Absolute Pressure; GP = Gauge Pressure; DP = Differential Pressure;
MR = Multirange; MV = Multivariable; PP = Premium Performance

(b) Models IAP10, IAP10S, IGP10, IGP10S, and IGP25 are direct connect transmitters; and Models IAP20, IGP20, IDP10, IDP10S, IDP25, IDP50, IMV25, IMV30, and IMV31 are bracket mounted transmitters.

Table 8. I/A Series Electronic Analog Output Transmitters

Transmitter Model	Version -A 4 to 20 mA dc Analog Output	Version -V 1 to 5 V dc Analog Output
IAP10/IAP20 Absolute Pressure Transmitters	PSS 2A-1C13 C	PSS 2A-1C13 D
IGP10/IGP20 Gauge Pressure Transmitters	PSS 2A-1C13 C	PSS 2A-1C13 D
IAP10/IGP10 with Integral Sanitary Connectors	PSS 2A-1C13 K	PSS 2A-1C13 K
IAP10/IGP10 with Integral Pulp & Paper Connectors	PSS 2A-1C13 L	PSS 2A-1C13 L
IGP10 High Gauge Pressure Transmitter	PSS 2A-1C13 F	PSS 2A-1C13 F
IDP10 d/p Cell Transmitter	PSS 2A-1C14 C	PSS 2A-1C13 D

ORDERING INSTRUCTIONS

1. Pressure Seal Model Number
(see examples show with each Seal Model Code).
2. Applicable Transmitter Model Number
 - Refer to applicable Transmitter PSS for Model Code
 - Note the linkage between the Seal and Transmitter Model Numbers as shown in the examples in this PSS.
3. Seal Tank Spud accessories for the PSSSR and PSSST Seals.
4. Transmitter options/accessories not offered in the Transmitter Model Code. See PSS 2A-1Z9 E Transmitter Options and Accessories document.

OTHER FOXBORO PRODUCTS

Invensys provides a broad range of measurement and instrument products, including solutions for pressure, flow, analytical, positioners, temperature, controlling and recording. For a listing of these offerings, visit our web site at:

www.invensys.com

Invensys
10900 Equity Drive
Houston, TX 77041
United States of America
<http://www.invensys.com>

Global Customer Support
Inside U.S.: 1-866-746-6477
Outside U.S.: 1-508-549-2424 or contact
your local Invensys representative.
Website: <http://support.ips.invensys.com>

Invensys, Foxboro, and I/A Series are trademarks of Invensys plc, its subsidiaries, and affiliates. All other brand names may be trademarks of their respective owners.

Copyright 2001-2014 Invensys Systems, Inc.
All rights reserved