

870IT Intelligent Electrochemical Transmitter Conversion Kit Kit-C-BS806ZP

To Add Rain Door Assembly

Table 1. Parts List

Item	Description	Part No.
1	Rain Door Assembly	BS806ZF
1	Magnetic Strip	L0117JE
1	Instruction	MI 611-213

Procedure:

1. Remove paper strip from self-adhering surface of magnetic strip and secure magnetic strip in recess of faceplate as shown in Figure 1.
2. Remove two large cross recess screws and two small cross recess screws from trim plate.
3. Insert hinge pins of new rain door in recesses under trim plate as shown in Figure 2 and replace screws.

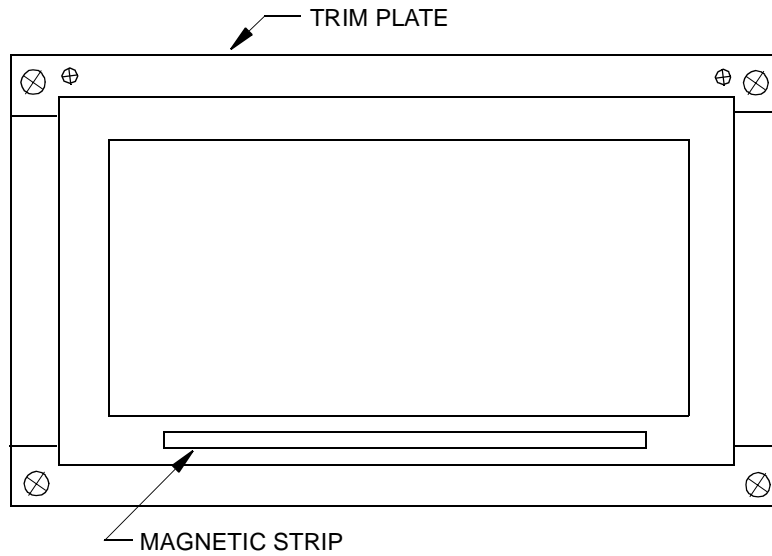

Figure 1.

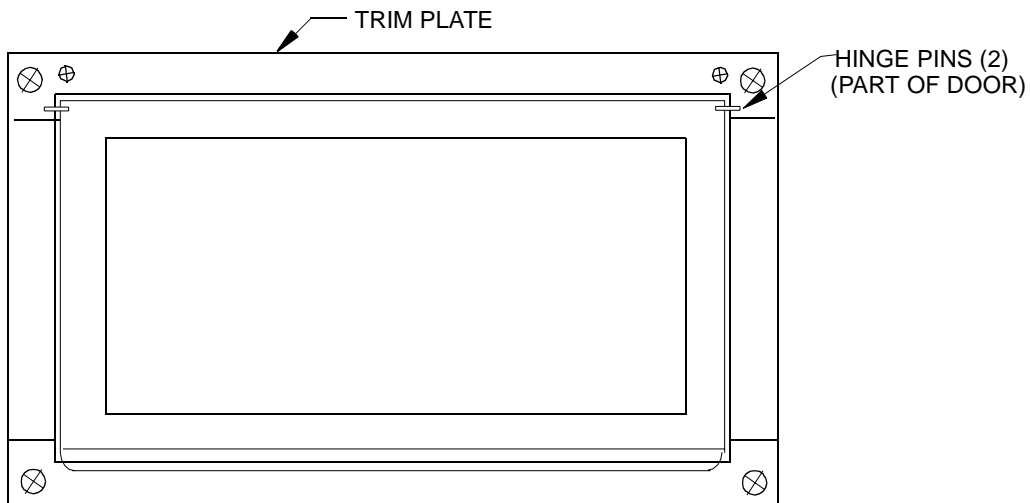

Figure 2.

ISSUE DATES

OCT 1995
FEB 1997

Vertical lines to right of text or illustrations indicate areas changed at last issue date.

The Foxboro Company
33 Commercial Street
Foxboro, MA 02035-2099
United States of America
<http://www.foxboro.com>
Inside U.S.: 1-888-FOXBORO
(1-888-369-2676)
Outside U.S.: Contact your
local Foxboro Representative.
Facsimile: (508) 549-4992

Foxboro, Fox, and I/A Series are trademarks of The Foxboro Company.
Siebe is a registered trademark of Siebe, plc.

Copyright 1995-1997 by The Foxboro Company
All rights reserved