

**873RS Series
Electrochemical Analyzers
for Resistivity Measurements**

Style C



Contents

Figures.....	vii
Tables.....	ix
1. Introduction.....	1
Quick Start	1
Purpose	1
Checking Factory Configuration	1
Verifying Valid Measurements	1
Sensor Wiring	1
Sensor Calibration	2
Looking for More Information?	2
General Description	3
Instrument Features	3
RoHS/WEEE Compliance Statement	5
Analyzer Identification	5
Standard Specifications	6
Product Safety Specifications	8
2. Installation.....	9
Mounting to a Panel - Plastic Enclosure 873RS-__ P	9
Mounting to a Panel – Metal Enclosure 873RS-__ W	10
Mounting to a Pipe (Metal Enclosure Only) 873RS-__ Y	11
Mounting to a Surface, Movable Mount (Metal Enclosure Only) 873RS-__ Z	12
Mounting to a Surface, Fixed Mount (Metal Enclosure Only) 873RS-__ X	14
Wiring of Plastic Enclosure	16
Wiring of Metal Enclosure	17
3. Operation.....	19
Overview	19
Display	19
Keypad	20
Operate Mode	22
Temp Key	22
View Setup Entries	23
4. Configuration.....	25
Overview	25

Configure Mode	25
Security Code	25
Unlocking Analyzer Using Security Code	26
Locking Analyzer Using Security Code	26
Configuration Setup Entries	26
CELL Display and Output Configuration (CELL)	28
Holding the Analog Output (Hold)	29
Compensation and Damping (Cd)	31
General Information Alarms	31
Setting Alarm Level(s)	32
H Alarm Configuration (HAC)	33
Alarm Timers (HAtt, HAFt and HAdL)	35
L Alarm Configuration (LAC)	37
Alarm Timers (LAtt, LAft, and LAdL)	39
User-Defined Upper Measurement Limit (UL)	41
User-Defined Lower Measurement Limit (LL)	42
User-Defined Upper Temperature Limit (UtL)	42
User-Defined Lower Temperature Limit (LtL)	42
Scaling Analog Outputs	42
Output #1's 100% Analog Value (HO1)	43
Output #1's 0% Analog Value (LO1)	43
Output #2's 100% Analog Value (H02)	43
Output #2's 0% Analog Value (L02)	44
Basic Setup Entries	45
Unlocking Basic Setup Entries (bL)	46
Changing the Full Scale Range (FSC)	46
Changing the Temperature Circuitry	47
Changing the Analog Output	53
Changing the Security Code (LCC)	57
5. Calibration	59
Electronic Bench Calibration	59
Calibrating the Analyzer to a Specific Sensor	65
Temperature Cell Factor (tCF1 and tCF2) and Cell Factor (CF1 and CF2) Adjustments ..	65
Determining tCF	66
Entering a tCF Value	67
Determining (or Verifying) a CF	68
Entering a CF Value	69
6. Diagnostics.....	71
Troubleshooting	71
Error Codes	72
7. User Notes.....	75
Single Sensor Use	75
Dual Sensor Use	77

Redundant Sensor Operation	78
Backup Sensor Operation	79
8. Alarm Contact Maintenance.....	83
9. Warranty.....	85
Index.....	87

Figures

1	Metal Enclosure Rear Panel Wiring	1
2	Plastic Enclosure Rear Panel Wiring	2
3	Typical Front Panel Display and Keypad	5
4	Data Label Location	5
5	Mounting to Panel - Plastic Enclosure	9
6	Mounting to Panel - Metal Enclosure	10
7	Metal Enclosure - Pipe Mounting	11
8	Metal Enclosure - Movable Mount	13
9	Metal Enclosure - Fixed Mount	15
10	Plastic Enclosure Rear Panel Wiring	16
11	Metal Enclosure Rear Panel Wiring	18
12	Display and Keypad	20
13	Possible Alarm Wiring and Configuration Choices	32
14	ON/OFF Relationship between HAtt, HAFt and HAdL	36
15	Flow Diagram for Alarm Timer Logic	37
16	ON/OFF Relationship between LAtt, LAFt, and LAdL	40
17	Flow Diagram for Alarm Timer Logic	41
18	Jumpers for Temperature Compensation	49
19	Thermistor Temperature Simulation (Metal Enclosure Shown)	51
20	RTD Temperature Simulation (Plastic Enclosure Shown)	52
21	Jumpers for Changing Analog Output	54
22	Output Terminals and Volt/Amm Meter (Plastic Enclosure Shown)	57
23	Temperature Simulation (NEMA 4X Enclosure Shown)	61
24	Bench Calibration (NEMA 4X Enclosure Shown)	63
25	Sensor Identification	66
26	Alarm Contact Reconditioning Circuit	83

Tables

1	Product Safety Specifications	8
2	Recommended Conduit and Fitting (Due to Internal Size Restraints)	18
3	Key Functions	21
4	Configuration Setup Entries	27
5	CELL Code - Display and Output Configuration	29
6	Hold Code - Hold Analog Output and Alarms	30
7	Cd Code - Compensation and Damping	31
8	HAC Code - High Alarm Configuration	34
9	HAtt, HAFt, and HAdL Time Codes	35
10	LAC Code - Low Alarm Configuration	38
11	LAtt, LAFt, and LAdL Time Codes	39
12	Basic Setup Entry Selection	45
13	Jumper Positions for Temperature Transducer	48
14	Jumper Position for the Various Analog Outputs	53
15	Troubleshooting Symptoms	71
16	Error/Alarm Messages	72

1. Introduction

Quick Start

Purpose

The purpose of this section is to:

- ◆ Help you to wire your analyzer.
- ◆ Familiarize you with the analyzer configuration as received from the factory.
- ◆ Assist you in verifying that your analyzer is in calibration.
- ◆ Explain normal operation.

Checking Factory Configuration

Refer to analyzer label and Configuration setup entries in Table 4 on page 27 and Table 12 on page 45. There is space provided to make any notations you wish in the last column of each table.

Verifying Valid Measurements

Your analyzer was calibrated at the factory. Therefore, you should not have to calibrate it. However, if you wish to check the calibration, install resistors from the resistor kit included and follow procedures from “Electronic Bench Calibration” on page 59, with the analyzer LOCKED.

Sensor Wiring

Wiring installation must comply with any existing local regulations.

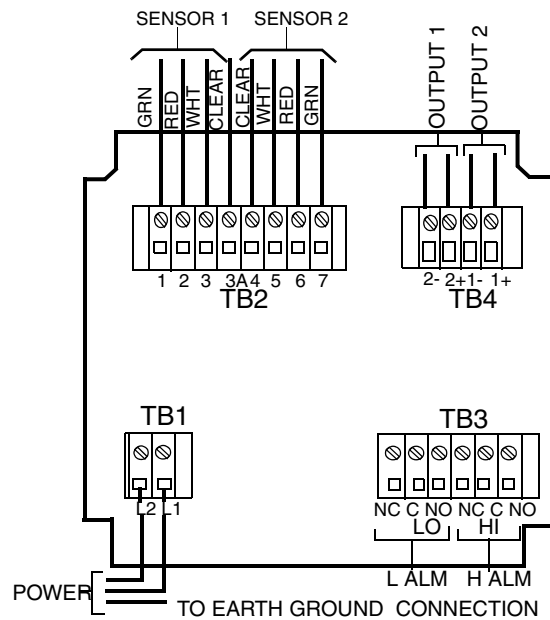

Figure 1. Metal Enclosure Rear Panel Wiring

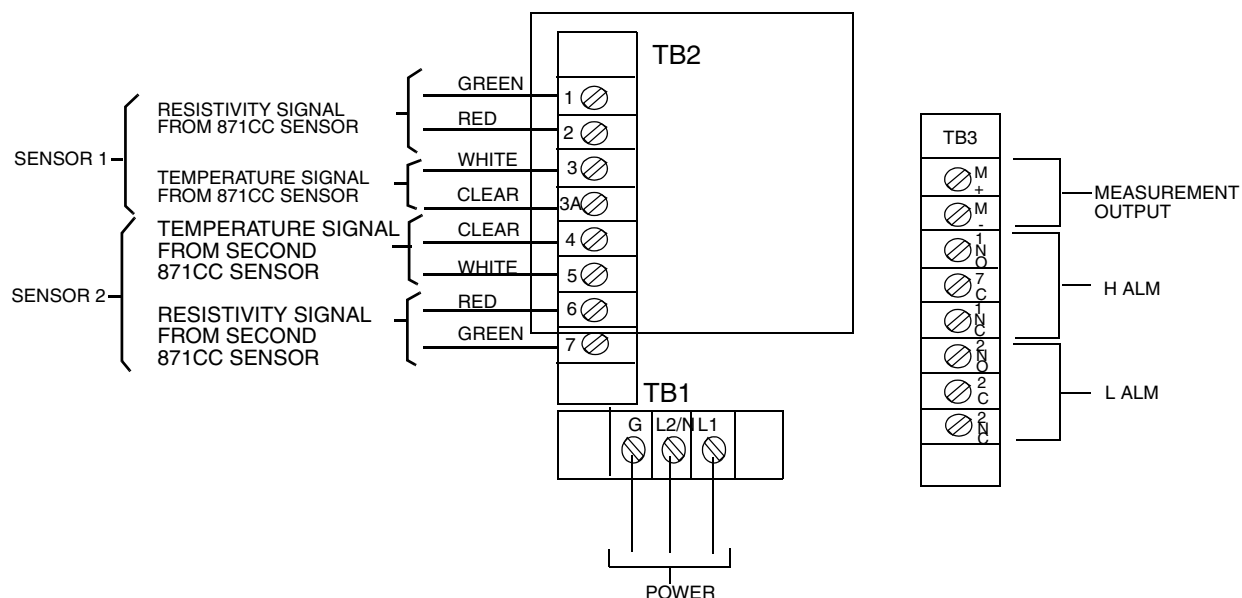

Figure 2. Plastic Enclosure Rear Panel Wiring

Sensor Calibration

871CC “resistivity” sensors are manufactured to be $\pm 2\%$ accurate of their nominal 0.1 cm^{-1} cell value. These sensors are also tested and labeled with their individual cell factors (CF) as well as the true temperature at which a thermistor is exactly $100 \text{ k}\Omega$ or RTD is $100 \text{ }\Omega$. The overall system accuracy may be improved by entering the individual sensor parameters into the analyzer. “Entering a tCF Value” on page 67 and “Entering a CF Value” on page 69 are the pertinent procedures to follow to calibrate the 873RS analyzer for the individual sensor being used.

Looking for More Information?

For more detailed information, refer to the following sections of this manual:

For installation information, refer to “Installation” on page 9. For dimensional information, refer to DP 611-163.

For detailed explanation of the controls and indicators, refer to “Operation” on page 19.

For detailed configuration instructions, refer to “Configuration” on page 25.

For detailed calibration instructions, refer to “Calibration” on page 59.

If you need additional help, please call the Electrochemical Service Center at 1-508-549-4730 in the U.S.A. or call your local Invensys Foxboro representative.

General Description

The 873RS Resistivity Analyzer interprets the resistivity of aqueous solutions. Its measurement display may be read in either megohm-cm ($M\Omega\bullet\text{cm}$), or percent (%). Solution temperature is also measured by the 873RS for automatic temperature compensation and may be displayed whenever the user wants.

It provides an isolated output signal proportional to the measurement for transmission to an external receiver. The general purpose panel-mounted analyzer transmits one output signal; the field-mounted (NEMA 4X enclosure) analyzers transmits two output signals.

Instrument Features

Described below are some of the features of the 873RS Electrochemical Analyzer:

- ◆ Plastic or Metal Enclosure
- ◆ Dual Sensor Input
- ◆ Dual Alarms
- ◆ Dual Analog Outputs on Metal Enclosure
- ◆ EEPROM Memory
- ◆ Instrument Security Code
- ◆ Hazardous Area Classification, Metal Enclosure only
- ◆ Front Panel Display
- ◆ Front Panel Keypad
- ◆ Application Flexibility
- ◆ Storm Door Option

Enclosures

The plastic enclosure is intended for panel mounting in general purpose locations, and mounts in a 1/4 DIN size panel cutout. It meets the enclosure ratings of NEMA 1, CSA Enclosure 1, and IEC Degree of Protection IP-45.

The metal enclosure is intended for field locations and may be panel, pipe, or surface mounted. The housing is extruded aluminum coated with a tough epoxy-based paint. The enclosure is watertight, dusttight, corrosion-resistant, meeting the enclosure ratings of NEMA 4X, CSA Enclosure 4X, and IEC Degree of Protection IP-65, and fits in a 92 x 92 mm (3.6 x 3.6 in) panel cutout (1/4 DIN size). The metal enclosure provides protection against radio frequency interference (RFI) and electromagnetic interference (EMI).

Dual Alarms

Two independent, nonpowered Form C contacts, rated 5 A noninductive, 125 V ac/30 V dc (minimum current rating 1 A). Inductive loads can be driven with external surge-absorbing devices installed across contact terminations.

—! CAUTION

When the contacts are used at signal levels of less than 20 W, contact function may become unreliable over time due to the formation of an oxide layer on the contacts. See “Alarm Contact Maintenance” on page 83.

No Battery Backup Required

Non-volatile EEPROM memory is employed to protect all operating parameters and calibration data in the event of power interruptions.

Instrument Security Code

A combination code lock method, user configurable, provides protection of operational parameters from accidental or unauthorized access.

Front Panel Display

The instrument's display consists of a four-digit bank of red LEDs with decimal point, and an illuminated legend area to the right of the LEDs (see Figure 3). The 14.2 mm (0.56 in) display height provides visibility at a distance up to 6 m (20 ft) through a protective window on the front panel.

The measurement value is the normally displayed data. If other data is displayed because of prior keypad operations, the display automatically defaults to the measurement value 10 seconds (called *timing out*) after the last keypad depression.

If no fault or alarm conditions are detected in the instrument, the measurement value is steadily displayed. If fault or alarm conditions are detected, the display alternately displays, at a 1 second rate, the measurement value and a fault or alarm message.

Front Panel Keypad

The instrument front panel keypad consists of eight keys. Certain keys are for fixed functions; other keys are for split functions. The upper function of a split function key is actuated by pressing the shift key in conjunction with the split function key. Refer to Figure 3.

Application Flexibility

The 873 Analyzer offers application flexibility through its standard software package. The software, run on the internal microprocessor, allows the user to define and set operating parameters particular to his application. These parameters fall into four general categories: Measurement Range, Alarm Configuration, Diagnostics, and Output Characterization. These parameters are retained in the EEPROM nonvolatile memory. Following power interruptions, all operating parameters are maintained.

Storm Door Option

This door is attached to the top front surface of the enclosure. It is used to prevent accidental or inadvertent actuation of front panel controls, particularly in field mounting applications. The transparent door allows viewing of the display and is hinged for easy access to the front panel controls.

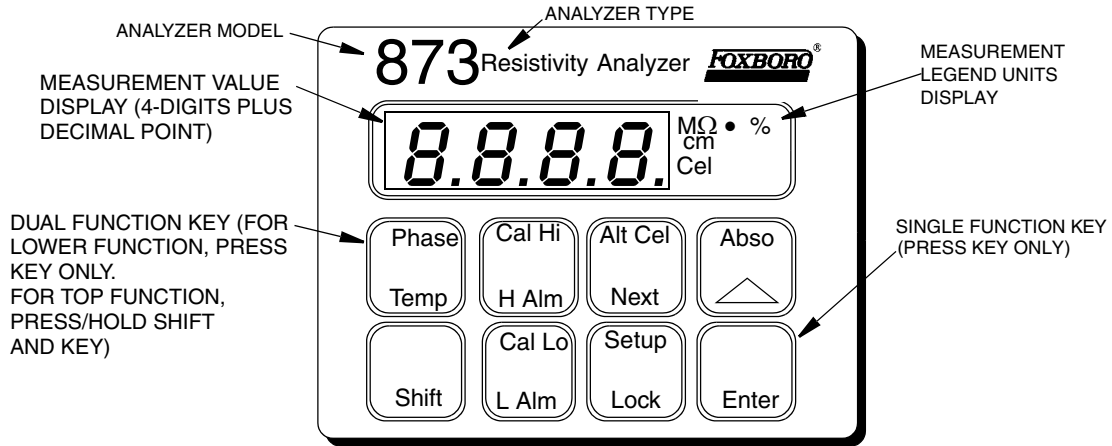

Figure 3. Typical Front Panel Display and Keypad

RoHS/WEEE Compliance Statement

This product is exempt from the European Directive 2002/95/EC on the restriction of the use of certain hazardous substances in electrical and electronic equipment (RoHS), as provided by Article 2 of that Directive in conjunction with the Product Category #9: “Monitoring and Control Instruments.”

This product complies with the European Directive 2002/96/EC on Waste Electrical and Electronic Equipment (WEEE) and is marked accordingly. At end of product life users should contact [Invensys Foxboro](#) for return authorization and shipment instructions.

Analyzer Identification

A data label is fastened to the side surface of the enclosure. This dataplate provides Model Number and other information pertinent to the particular analyzer purchased. Refer to Figure 4.

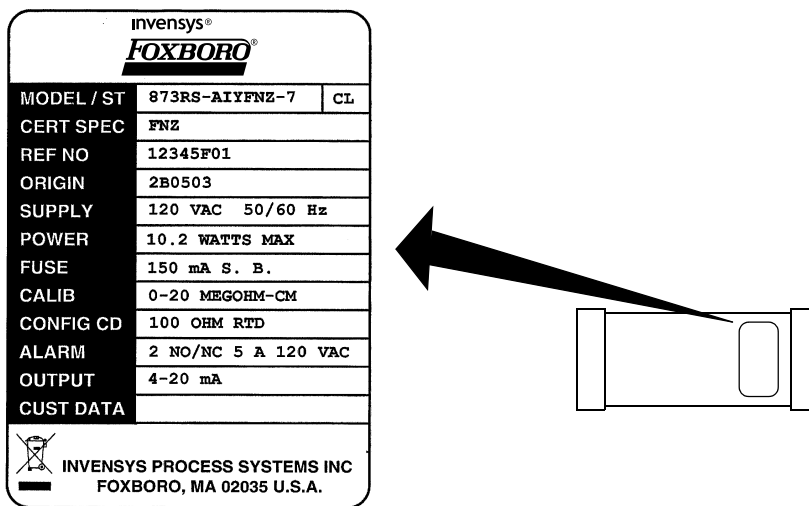

Figure 4. Data Label Location

Standard Specifications

Supply Voltages	<ul style="list-style-type: none"> -A 120 V ac -B 220 V ac -C 240 V ac -E 24 V ac -J 100 V ac
Supply Frequency	50 or 60 Hz, ± 3 Hz
Output Signal	<ul style="list-style-type: none"> I 4-20 mA isolated T 0-10 V dc isolated E 0-20 mA isolated
Ambient Temperature Limits	-25 to +55°C (-13 to +131°F)
Measurement Ranges	<ul style="list-style-type: none"> 0 to 2.000 MΩ•cm (minimum) 0 to 5.000 MΩ•cm 0 to 10.00 MΩ•cm 0 to 15.00 MΩ•cm 0 to 20.00 MΩ•cm (maximum)
Temperature Measurement Range	-17 to +150°C (0 to 302°F)
Temperature Compensation Range	0 to 120°C (32 to 248°F)
Relative Humidity Limits	5 to 95%, noncondensing
Accuracy of Analyzer	$\pm 0.5\%$ of FSC range utilized at 25°C
Analyzer Identification	Refer to Figure 4.
Dimensions	<ul style="list-style-type: none"> Plastic Enclosure 92(H) x 92(W) x 183(L) mm, 3.6 x 3.6 x 7.6 in Metal Enclosure 92(H) x 92(W) x 259(L) mm, 3.6 x 3.6 x 10.1 in
Enclosure/Mounting Options	<ul style="list-style-type: none"> -P Plastic (Noryl) Panel Mount -W Metal Panel Mount -X Metal Surface Mount -Y Metal Pipe Mount -Z Metal Movable Surface Mount
Approximate Mass	<ul style="list-style-type: none"> Plastic Enclosure 0.68 kg (1.5 lb) Metal Enclosure (NEMA 4X) (with Brackets) <ul style="list-style-type: none"> Panel Mounting 1.54 kg (3.4 lb) Pipe Mounting 2.31 kg (5.1 lb) Fixed Surface Mounting 2.22 kg (4.9 lb) Movable Surface Mounting 3.13 kg (6.9 lb)
Instrument Response	Three second response for 90% change when used for single sensor measurement (when zero measurement damping is selected in Configuration Code). Temperature response is 15 seconds maximum. Seven second response for 90% change when used for dual sensor measurement.

Measurement Damping	Choice of 0, 10, 20, 40, 80, or 160 second, additional damping configurable from keypad. Damping affects displayed parameters and analog outputs.
Alarms	<ul style="list-style-type: none"> • Two alarms configurable via keypad • Individual set points continuously adjustable 0 to full scale via keypad • Hysteresis selection for both alarms; 0 to 99% of full scale value, configurable via keypad • Three timers for both alarms, adjustable 0 to 99 minutes, configurable via keypad. Allows for trigger timing and on/off control with delay. Timers can be set to allow chemical feed, then delay for chemical concentration control.
Alarm Contacts	<p>Two independent, nonpowered Form C contacts. Rated 5 A noninductive, 125 V ac/30 V dc (minimum current rating 1 A). Inductive loads can be driven with external surge-absorbing devices installed across contact terminations.</p> <p>CAUTION: When the contacts are used at signal levels of less than 20 W, contact function may become unreliable over time due to the formation of an oxide layer on the contacts. See “Alarm Contact Maintenance” on page 83.</p>
Alarm Indication	Alarm status alternately displayed with measurement on LED display
Analog Output (dual outputs on metal units)	0-10 V (minimum load 1 k Ω)
Isolated, powered outputs	0-20 mA (800 Ω maximum loop resistance)
RFI Susceptibility (when all sensor and power cables are enclosed in a grounded conduit)	4-20 mA (800 Ω maximum loop resistance)
Electromagnetic Compatibility (EMC)	<p>Plastic Enclosure: <0.5 V/m from 27 to 1000 MHz</p> <p>Metal Enclosure: >10 V/m from 27 to 1000 MHz</p> <p>The Model 873RS Electrochemical Analyzer, 220 V ac or 240 V ac systems with metal enclosure, comply with the requirements of the European EMC Directive 89/336/EEC when the sensor cable, power cable, and I/O cables are enclosed in rigid metal conduit. See Table 2 on page 18.</p> <p>The plastic case units are intended for mounting in metal consoles or cabinets. The plastic case units will comply with the European EMC Directive 89/336/EEC when mounted in a metal enclosure and the I/O cables extending outside the enclosure are enclosed in metal conduit. See Table 2 on page 18.</p>

Product Safety Specifications

Table 1. Product Safety Specifications

Testing Laboratory, Types of Protection, and Area Classification	Application Conditions	Electrical Safety Design Code
FM for use in general purpose (ordinary) locations.		FGZ
FM nonincendive for use in Class I, II, Division 2, groups A, B, C, D, E, and G, hazardous locations.	For instruments with metal enclosure only. Temperature Class T6.	FNZ
CSA (Canada) for use in general purpose (ordinary) locations.	24 V, 100 V, and 120 V ac (Supply Option -A, -E, -J) only.	CGZ
CSA (Canada) suitable for use in Class I, Division 2, Groups A, B, C, and D; hazardous locations.	For instruments with metal enclosure only. 24 V, 100 V, and 120 V ac (Supply Option -A, -E, -J) only. Temperature Class T6.	CNZ

— NOTE —

The Analyzer has been designed to meet the electrical safety descriptions listed in the table above. For detailed information or status of testing laboratory approvals/certifications, contact your Invensys Foxboro representative.

— ⚠ CAUTION —

1. When replacing covers on the 873 metal case, use Loctite (Part No. S0106ML) on the threads for the front cover and Lubriplate (Part No. X0114AT) on the threads for the rear cover. Do not mix.
 2. Exposure to some chemicals may degrade the sealing properties of Polybutylene Teraethalate and Epoxy Magnacraft 276XAXH-24 used in relays K1 and K3. These materials are sensitive to acetone, MEK, and acids. Periodically inspect relays K1 and K3 for any degradation of properties and replace if degradation is found.
-

2. Installation

—  **CAUTION** —

Under certain operating conditions, a static charge can build up in the measurement piping and dissipate through the sensor, damaging electrical components. This has happened when using plastic piping, high flow rates, and very clean water. As a countermeasure, placing a “dummy sensor” or other metal object connected to ground just prior to the measurement sensor helps to dissipate the charge, thus preventing ESD damage to analytical instrumentation. Please contact Invensys Foxboro for additional information on this issue.

Mounting to a Panel - Plastic Enclosure 873RS-__ P

The plastic enclosure is mounted to a panel as described below (see Figure 5).

1. Size panel opening in accordance with dimensions specified on DP 611-162.
2. Insert spring clips on each side of Analyzer.
3. Insert Analyzer in panel opening until side spring clips engage on panel.
4. From rear of panel (and Analyzer), attach and tighten the top and bottom mounting screws until analyzer is securely held in place.

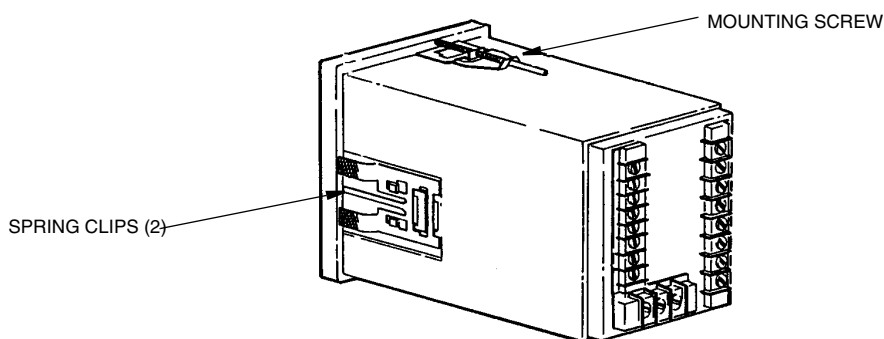

Figure 5. Mounting to Panel - Plastic Enclosure

Mounting to a Panel – Metal Enclosure 873RS-__ W

The metal enclosure can also be mounted to a panel as follows.

1. Make cutout in panel in accordance with DP 611-162.
2. Insert Analyzer through panel cutout and temporarily hold in place. (Rear bezel will have to be removed for this procedure.)
3. From rear of panel, slide plastic clamp onto enclosure until clamp latches (two) snap into two opposing slots on longitudinal edges of enclosure. See Figure 6.
4. Tighten screws (CW) on clamp latches until enclosure is secured to panel.
5. Reassemble rear bezel to enclosure using four screws.

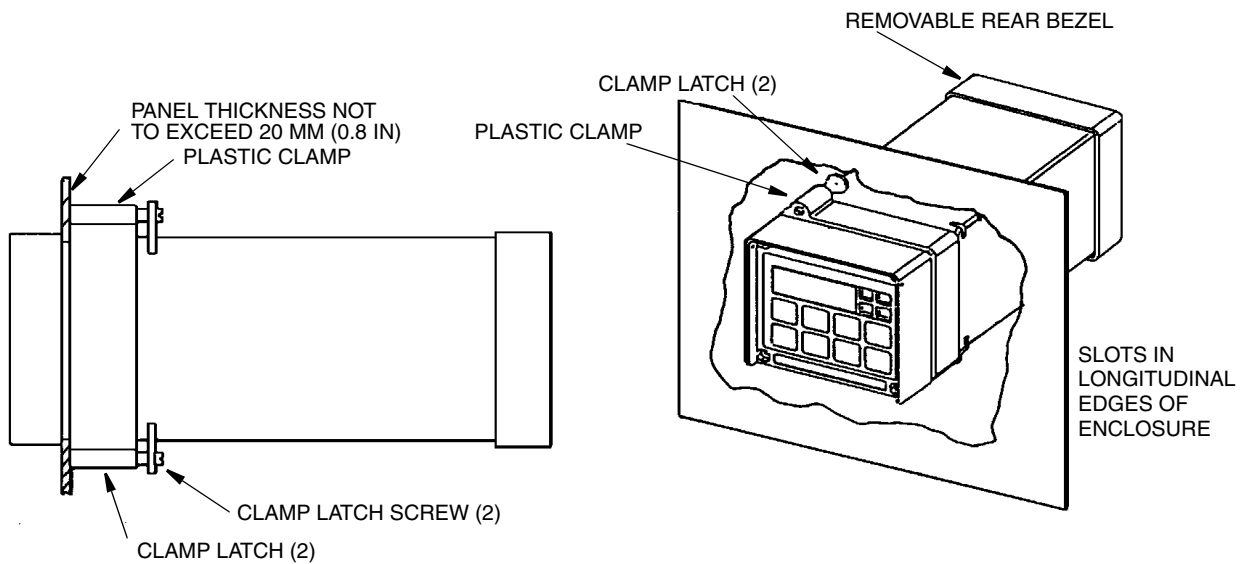

Figure 6. Mounting to Panel - Metal Enclosure

Mounting to a Pipe (Metal Enclosure Only) 873RS-__ Y

1. Locate horizontal or vertical DN 50 or 2 inch pipe.
2. Assemble universal mounting as follows:
 - a. Place hex bolts (5) through spacer (3) into support bracket (2).
 - b. Slide nylon washers (11) over bolts (5).
 - c. Slide bolts through pipe mounting bracket (1) and fasten assembly tightly with hardware designated 7, 6, and 13.
 - d. Attach pipe mounting bracket (1) to pipe using U-bolts (12) and hardware designated 6 and 13.
3. Slide Analyzer into support bracket and slide strap clamp (4) onto Analyzer. Using two screws, nuts, and washers, attach strap clamp to support bracket to secure Analyzer.

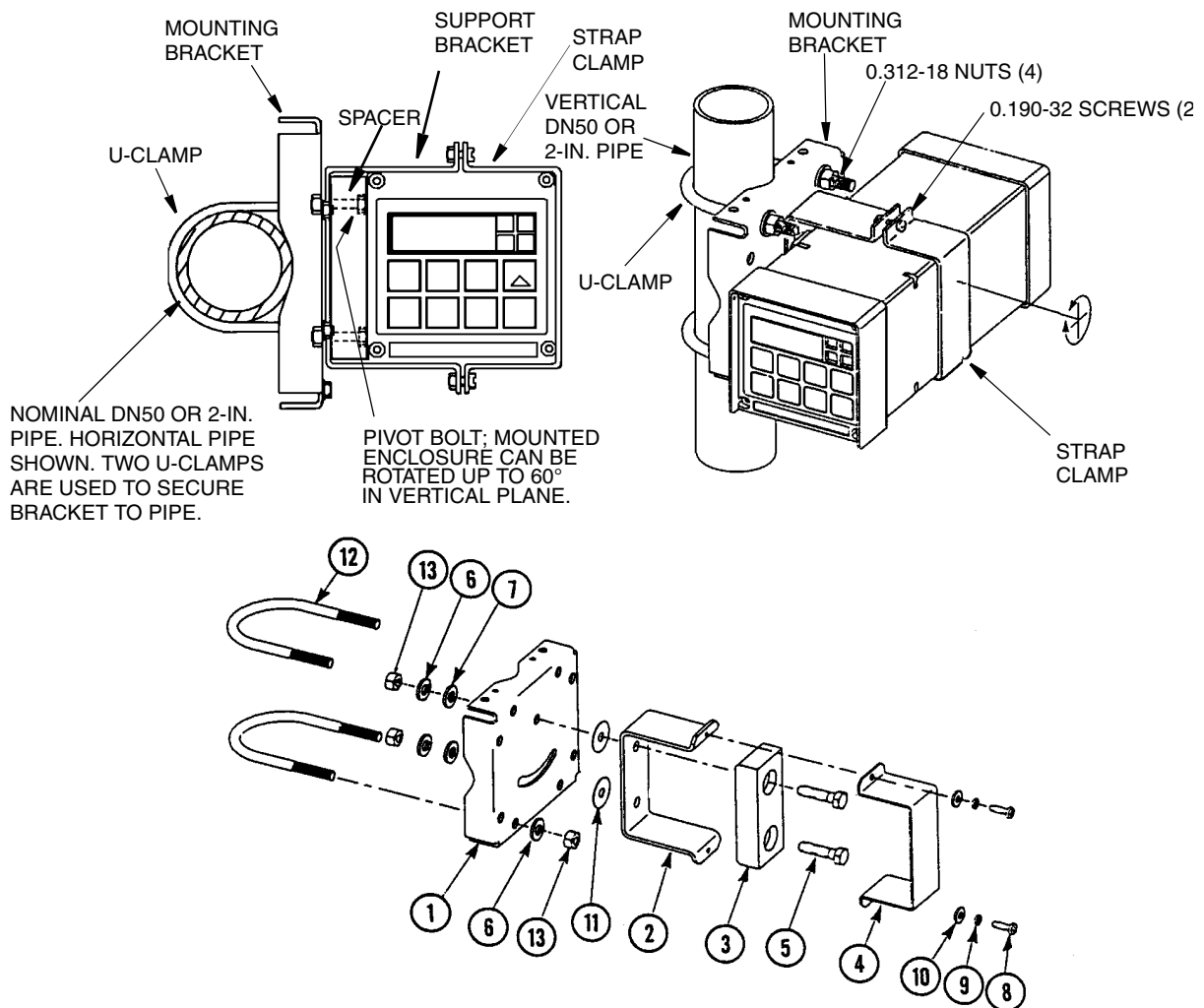

Figure 7. Metal Enclosure - Pipe Mounting

Mounting to a Surface, Movable Mount (Metal Enclosure Only) 873RS-__ Z

1. Locate surface on which you wish to mount the Analyzer.
2. Referring to Figure 8, use wall bracket (12) as template for drilling four holes into mounting surface. Notice that the holes in the wall bracket are 9.53 mm (0.375 in) in diameter.
3. Attach wall bracket (12) to surface using four bolts, washers, and nuts.
4. Assemble universal mounting as follows:
 - a. Place hex bolts (5) through spacer (3) into support bracket (2).
 - b. Slide nylon washers (11) over bolts (5).
 - c. Slide bolts through universal mounting bracket (1) and fasten assembly finger tight with hardware designated 9, 10, and 16.
5. Slide Analyzer into support bracket and slide strap clamp (4) onto Analyzer. Using two screws, nuts, and washers, attach strap clamp to support bracket to secure Analyzer.
6. Lift entire assembly of Step 5, align mounting bracket and wall bracket pivot bolt holes, and then insert pivot bolt (13) through wall and mounting bracket into nylon washers and locking nut.
7. Rotate bracket and Analyzer assembly in horizontal plane to desired position and lock in place using screw and washer.

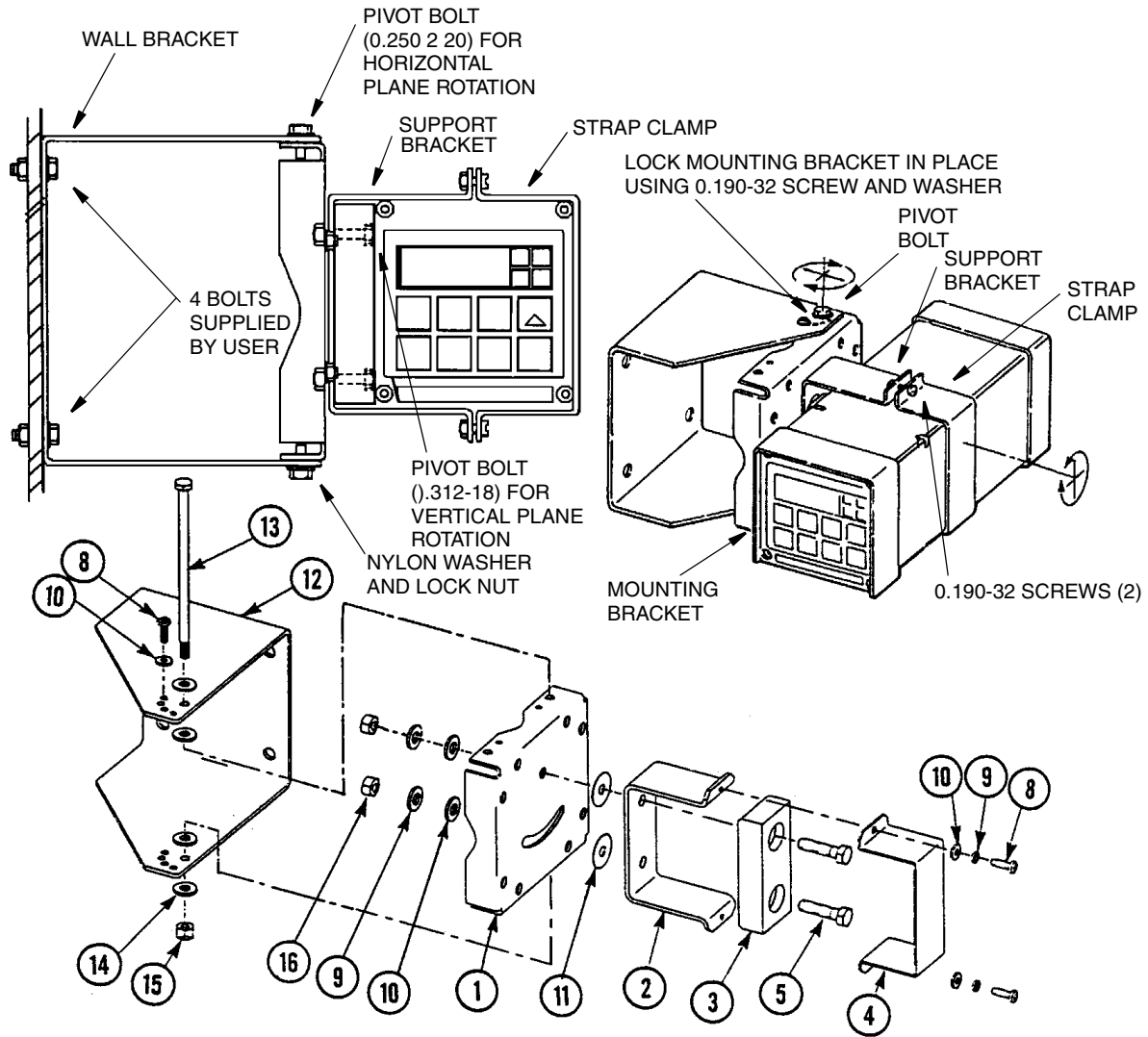

Figure 8. Metal Enclosure - Movable Mount

Mounting to a Surface, Fixed Mount (Metal Enclosure Only) 873RS-__ X

1. Locate mounting surface for Analyzer.
2. Referring to Figure 9, use mounting bracket (1) as template for drilling four holes into mounting surface. Notice that holes in mounting bracket are 8.74 mm (0.344 in) in diameter. Do not attach mounting bracket to surface at this time.
3. Assemble universal mounting as follows:
 - a. Place hex bolts (5) through spacer (3) into support bracket (2).
 - b. Slide nylon washers (11) over bolts (5).
 - c. Slide bolts through universal mounting bracket (1) and fasten assembly together with hardware designated 7, 6, and 12.
 - d. Attach universal mounting bracket (1) to wall.
4. Slide Analyzer into support bracket and slide strap clamp (4) onto Analyzer. Using two screws, nuts, and washers, attach strap clamp to support bracket to secure Analyzer.

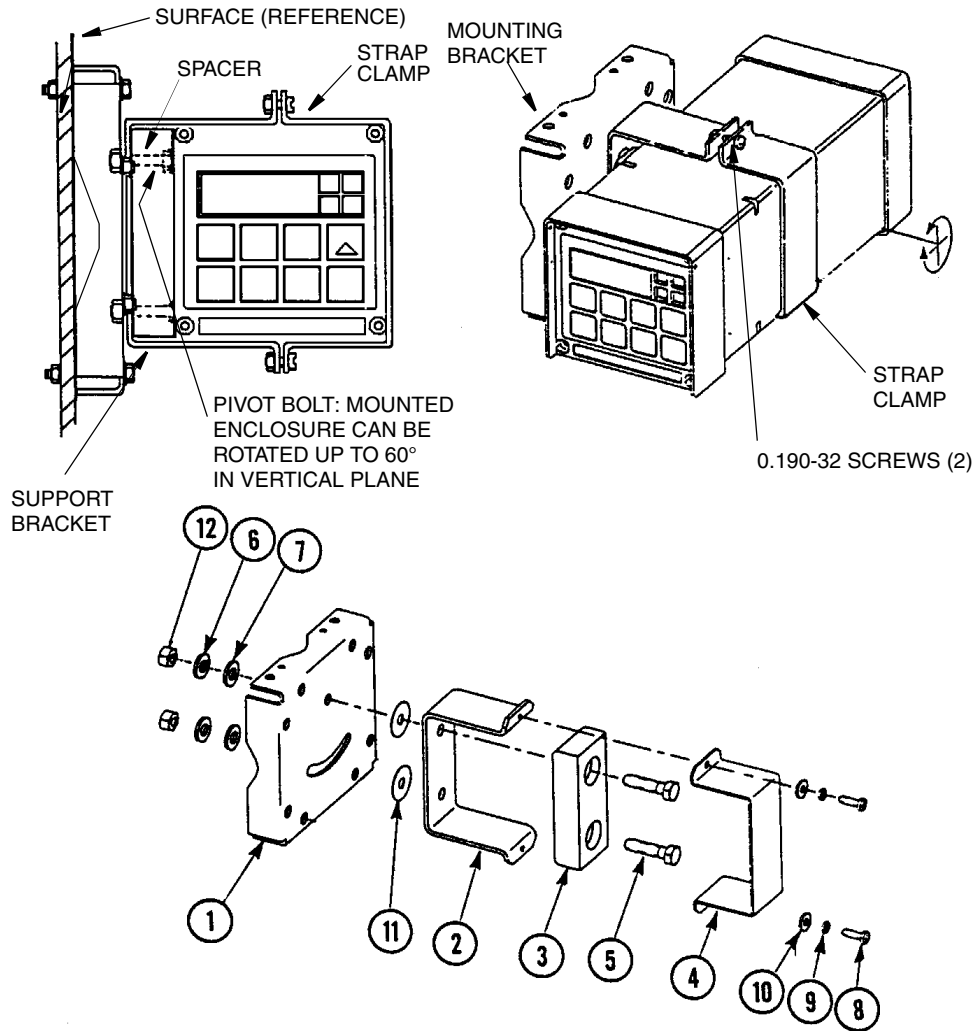

Figure 9. Metal Enclosure - Fixed Mount

Wiring of Plastic Enclosure

1. Remove optional rear cover assembly BS805QK, if present.
2. Connect H and L alarm wires to TB3 as shown in Figure 10. Failsafe operation requires connections be made between NC and C and the alarms be configured active. Refer to “General Information Alarms” on page 31.
3. Connect wires from external circuit for Analyzer measurement output to terminals TB3–1(+) and TB3–2(–). Refer to Figure 10.

— NOTE

1. Only sensors with 0.1 cm^{-1} cell factor should be used with the 873RS Analyzer. Models 500, 900, 910, 920, 921, and 923 Series should not be used with the 873 Analyzer. 871CC Sensors A2 through F2 use a $100 \text{ k } \Omega$ thermistor for temperature compensation. Sensors K2 through M2 use a Pt 100 RTD for temperature compensation and are recommended for all measurements at elevated temperature.
 2. If sensors are to be used in a solution with a high applied voltage, the outer electrode of each sensor (green wire Terminals 1 and 7) must be connected to earth ground.
 3. Wiring installations must comply with any existing local regulations.
-
4. Remove factory-installed jumper assembly from terminal block TB2 and discard.
 5. Connect sensor wires to Analyzer terminal block (TB2) in accordance with Figure 10. If a single sensor is used with this Analyzer, it may be wired to either sensor input. See “CELL Display and Output Configuration (CELL)” on page 28, “H Alarm Configuration (HAC)” on page 33, and “L Alarm Configuration (LAC)” on page 37.
 6. Connect power wires to terminal block TB1 as shown in Figure 10.
 7. Attach optional rear panel cover, if present.

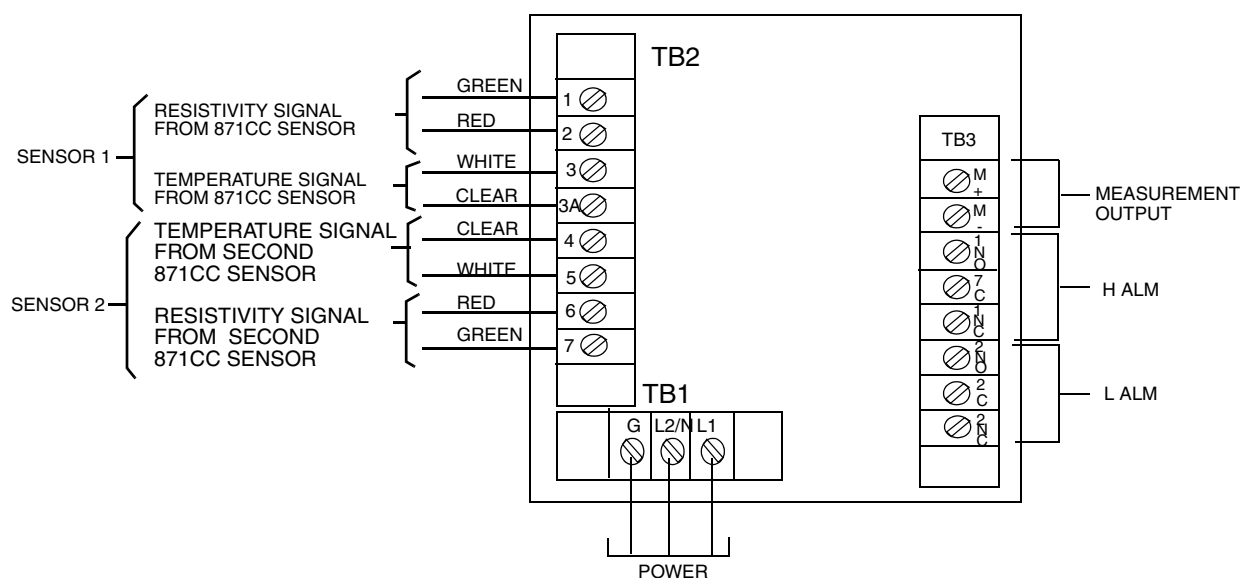

Figure 10. Plastic Enclosure Rear Panel Wiring

Wiring of Metal Enclosure

— NOTE

1. Wiring installations must comply with any existing local regulations.
 2. To maintain enclosure tightness such as NEMA 4X, CSA Enclosure 4X, or IEC Degree of Protection IP-65, wiring methods and fittings appropriate to the ratings must be used. See Table 2 on page 18. Alarm wires should run through the same conduit as the power wires. Sensor wires and analog output wires should be run through separate conduit openings.
-

1. Remove back cover to access terminal/power board.
2. Connect H and L Alarm wires to TB3 as shown in Figure 11. Failsafe operation requires connections to be made between contacts NO and C, and the alarms to configured active. Refer also to “General Information Alarms” on page 31.
3. Connect wires from external circuits for Analyzer temperature or measurement outputs to terminal TB4.

— NOTE

1. Only sensors with a 0.1 cm^{-1} cell factor should be used with the 873RS Analyzer. Models 500, 900, 910, 920, 921, and 923 Series should not be used with the 873 Analyzer. 871CC Sensors A2 through F2 use a $100 \text{ k}\Omega$ thermistor for temperature compensation. Sensors K2 through M2 use a Pt 100 RTD for temperature compensation and are recommended for all measurements at elevated temperature.
 2. If the sensors are to be used in a solution with a high applied voltage, the outer electrode from each sensor (green wire terminals 1 and 7) must be connected to earth ground.
-
4. Connect sensor wires to Analyzer terminal block TB2 as shown in Figure 11. If a single sensor is used with this Analyzer, it may be wired to either sensor input but must be configured properly. See “CELL Display and Output Configuration (CELL)” on page 28, “H Alarm Configuration (HAC)” on page 33, and “L Alarm Configuration (LAC)” on page 37.
 5. Connect power wires to terminal block 1 as indicated in Figure 11. The earth (ground) connection from the power cord should be connected to the stud located in the bottom of the case. The stud grounds the instrument and is mandatory for safe operation.

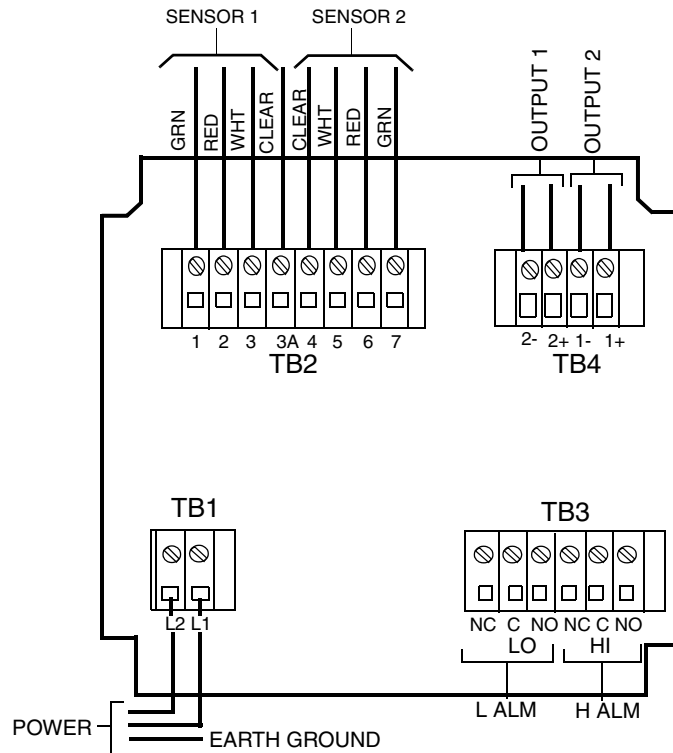

Figure 11. Metal Enclosure Rear Panel Wiring

Table 2. Recommended Conduit and Fitting (Due to Internal Size Restraints)

	Conduit	Fitting
Rigid Metal	1/2-inch Electrical Trade Size	T&B* #370
Semi-rigid Plastic	T&B #LTC 050	T&B #LT 50P or T&B #5362
Semi-rigid Plastic, Metal Core	Anaconda Type HC, 1/2-inch	T&B #LT 50P or T&B #5362
Flexible Plastic	T&B #EFC 050	T&B #LT 50P or T&B #5362

*Thomas & Betts Corp., 1001 Frontier Road, Bridgewater, NJ 08807-0993

NOTE

1. The cover screws are self-tapping and have a limited number of taps. Do not repeatedly remove and tighten these screws.
2. When replacing covers on the 873 metal case, use Loctite (Part No. S0106ML) on the threads for the front cover and Lubriplate (Part No. X0114AT) on the threads for the rear cover. Do not mix.
3. It is recommended that sensor and interconnect cable be run in 1/2 inch conduit for protection against moisture and mechanical damage. Do not run power or control wiring in the same conduit.

3. Operation

Overview

The 873 functions in two modes, OPERATE and CONFIGURE.

In the OPERATE Mode, the 873 automatically displays its measurement and outputs a proportional analog signal. Also, while in the OPERATE Mode, a user may read all the parameter settings and the solution temperature.

In the CONFIGURE Mode, the user may change any of the parameters previously entered. All 873 Analyzers are shipped configured, either with factory default settings or user defined parameters, as specified.

Utilizing either mode requires understanding the functions of both the keypad and display.

Display

The display, Figure 12, is presented in two parts, a measurement/settings display and a backlit engineering units/cell 2 display. There are four possible automatic measurement displays as follows:

- ◆ The measurement of Cell 1, expressed in $M\Omega \bullet m$.
- ◆ The measurement of Cell 2, expressed in $M\Omega \bullet cm$.
- ◆ The ratio between Cell 1 and Cell 2, expressed in %:

$$\frac{\text{Cell 1}}{\text{Cell 2}} \times 100 = \text{Percent}$$

Example:

Cell 1 is measuring 10.0 $M\Omega \bullet cm$ water. Cell 2 is measuring 17.1 $M\Omega \bullet cm$ water. Ratio would read 58.5%.

- ◆ The % rejection between Cell 1 and Cell 2, expressed in % is:

$$1 - \frac{\text{Cell 1}}{\text{Cell 2}} \times 100 = \text{Percent}$$

Example:

Cell 1 is measuring 10.0 $M\Omega \bullet cm$ water. Cell 2 is measuring 17.1 $M\Omega \bullet cm$ water. Percent rejection would read 41.5%.

To read anything other than the measurement or to make a configuration or calibration change requires keypad manipulations.

Keypad

The keypad, Figure 12, is made up of eight keys, six of which are dual function. The white lettered keys represent normal functions while the blue lettered keys represent the alternate function. To operate the white lettered keys, just push them. To operate the blue lettered keys, press/hold **Shift** and then press the key. The functions of all keys are presented in Table 3.

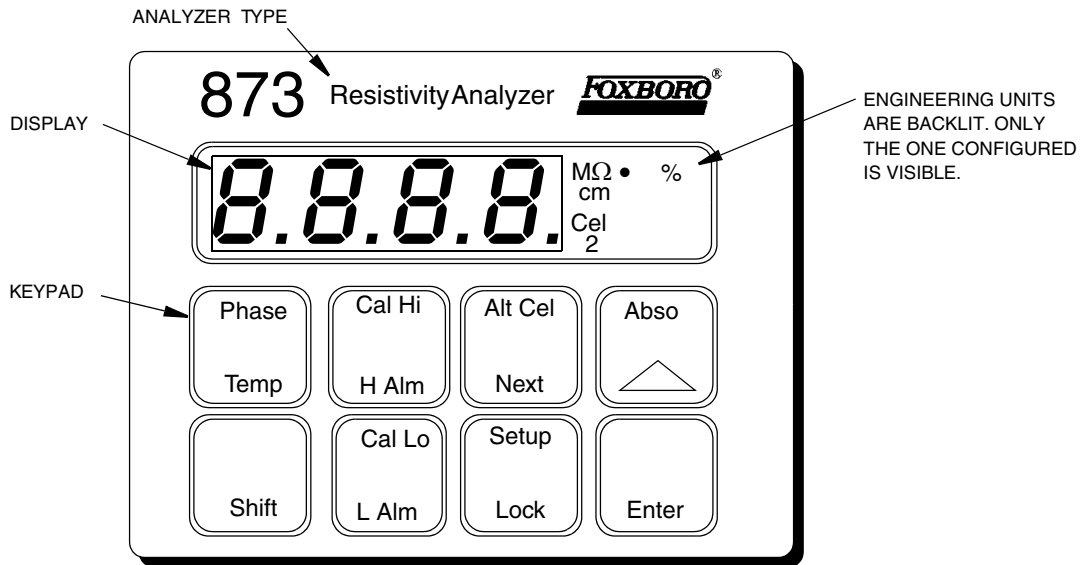









Figure 12. Display and Keypad

Table 3. Key Functions

	<p>Shift: Push and hold actuates the blue upper-function keys. Holding the Shift key while performing any function overrides the 10 second time-out allowing longer viewing of a value or code for as long as the key is held.</p>
	<p>Abso: Push this key to display the absolute resistivity value of cell, no temperature compensation. Pushing this key in Ratio or % Rejection displays absolute resistivity of Cell 1.</p> <p>Increment: Push to increase the value of the flickering number appearing on display. Each push causes the value to increase by one. Holding the key increases the count at approximately one per second. When 9 or the highest number in the configuration sequence is reached, display goes to 0.</p>
	<p>Phase: This key is used during bench calibration only to implement a phase calibration. Phase calibration provides calibration of the quadrature measurement circuitry. This accurately allows compensation of the resistivity measure for cable and sensor capacitance.</p> <p>Temp: Push and view the process medium temperature. This may be the actual temperature or a manually set value, as configured. The temperature is displayed with one decimal point which alternates with °C or °F as chosen.</p>
	<p>Enter: Is used to display the value or code of a setup entry. It is also used to select a parameter or code by entering the value or code into the memory.</p>
	<p>Alt Cell: If the display reads the resistivity of Cell 1, push Alt Cel to display Cell 2. If the display reads Cel 2, push Alt Cel to display the resistivity of Cell 1. Pushing this key when in % Rejection or Ratio displays the value of Cell 1.</p> <p>Next: Used to select one of the four display digits similar to a cursor except that it causes the digit to flicker. Also used to select the next entry choice of the setup function.</p>
	<p>Setup: Used to select and access analyzer configuration parameters and values.</p> <p>Lock: Used to display the lock status and lock or unlock the analyzer.</p>
	<p>Cal Lo: Used to set the lower calibration level (0 MΩ-cm) during bench calibration.</p> <p>L Alarm: Used to display and set the set point value for the relay associated with this alarm when configured as a measurement alarm.</p>
	<p>Cal Hi: Used to set the desired upper calibration level during bench calibration.</p> <p>H Alarm: Used to display and set the set point level for the relay associated with this alarm when configured as a measurement alarm.</p>

— **NOTE** —

1. Pressing **NEXT** and Δ simultaneously allows the user to step backward through the Setup program or digit place movement. One cannot reverse number count by this procedure.
 2. Pushing **SHIFT** and **ENTER** simultaneously circumvents the 10-second wait between Setup entries.
-

Operate Mode

As soon as the 873 Resistivity Analyzer is powered, it is in the Operate Mode. The instrument first conducts a self diagnostic test, momentarily displays the firmware version, and then automatically displays the measurement.

While in the Operate Mode, the user may view the measurement, view the temperature, and view all the parameter settings configured in the Configuration Setup Entries and Basic Setup Entries.

Temp Key

To view the process temperature, execute the following procedure:

Starting in the measurement mode, push **Temp**. The display then changes from the resistivity measurement to the process medium temperature or manually adjusted temperature.

If dual sensors are used, press/hold **Next** and press **Temp** to display the process medium temperature or manually adjusted temperature of Cel 2. The Cel 2 legend will be illuminated. Using this procedure, you can display the temperature but cannot change it.

The display is a rounded whole number with the temperature units (C or F) alternating with tenths of degrees. Once the unit is unlocked (see “Unlocking Analyzer Using Security Code” on page 26), the **Temp** key, used in conjunction with the increment (Δ) key, allows the temperature to be changed from $^{\circ}\text{C}$ to $^{\circ}\text{F}$ or vice versa, as well as allowing the use of manual temperature compensation at a given temperature (decimal shown after temperature). When **Temp** is pushed, the process temperature is displayed on the readout. Pushing Δ repeatedly causes the display to sequence from the displayed value through the following sequence example:

(1) 77.F	(2) 77.F.	(3) 25.C	(4) 25.C.
or	or	or	or
77.0	77.0	25.0	25.0.

When the decimal point appears after the C or F, the process temperature is compensated manually at the temperature displayed. To change that temperature, use **Next** and Δ to display the new value; then push **Enter**. Automatic temperature compensation, however, cannot be changed by this procedure. See “Calibrating the Analyzer to a Specific Sensor” on page 65. To return to automatic compensation, sequence the display to remove the decimal point after C or F. Then press **Enter**.

View Setup Entries

Setup Entries may be reviewed at any time.

To view any of the Setup Entries, follow the procedures given in the “Configuration Setup Entries” on page 26 or “Basic Setup Entries” on page 45, but do not “Unlock” the instrument.

When viewing the Setup Entries, you may page through the parameters as rapidly as you wish (**Shift + Setup**, **Next** one or more times). However, once **Enter** is pushed (**Enter** must be pushed to read a parameter value), you must wait 10 seconds (value is displayed for 10 seconds) for the parameter symbol to reappear. If the parameter value was not entered, pressing **Shift** and **Enter** together will circumvent the 10 second wait between Setup entries. The parameter symbols appear for 10 seconds also. If another key is not pushed in 10 seconds, the display defaults to the measurement. This feature is called *timing out*. To avoid *timing out* on any display, push and hold **Shift**.

To make changes to any Configuration Setup, see “Configuration” on page 25.

4. Configuration

Overview

This instrument is shipped with either factory settings (default values) or user defined settings, as specified per sales order. Table 4 on page 27 (Configuration Setup Entries) lists all the parameters that are more frequently changed and Table 12 on page 45 (Basic Setup Entries) lists the parameters that are calibration oriented. Both tables list the displayed symbol, the page containing information about the parameter, a description of the display, the factory default value, and a space in which to write user values.

Configuration is the keypad manipulation of some parameters to make the Analyzer function to the user's specifications. This section explains how to enter and change specific data through the keypad. Because reconfiguration may also involve wiring or jumper changes, care must be taken to ensure that all three items are checked before the Analyzer is placed into service either at startup or after any changes are made.

All 873 parameters are entered as 4-digit numerical codes. The code is chosen from tables shown with each parameter. There are several parameters that are entered as direct 4-digit values. Therefore, no table is supplied for those parameters. Successful configuration requires four simple steps:

1. Write down all your parameters in the spaces provided on the configuration tables.
2. Unlock the instrument.
3. Enter the 4-digit codes.
4. Lock the instrument.

Configure Mode

The Configure Mode is protected through two levels of security, one level for "Configuration Setup Entries" and two for "Basic Setup Entries." Any configuration change starts with Unlocking the instrument. Unlocking is accomplished by entering a security code through the keypad.

Security Code

There are two levels of security in the Analyzer. The first level of security protects against unauthorized change of Temp, H Alm, L Alm, Cal Lo, Cal Hi, and all the "Configuration Setup Entries" (of which there are 19) (refer to "Configuration Setup Entries" on page 26). The second level of security protects against the remaining 22 setup entries, called "Basic Setup Entries," 19 of which can be changed in the field (refer to "Basic Setup Entries" on page 45).

Note that any of the parameters discussed above can be viewed when the Analyzer is in the locked state. When displaying a parameter in the locked state, none of the digits flicker, and an attempt to change the parameter results in the message Loc on the display.

The same security code is used to unlock the unit in both levels of security. When the unit is unlocked at the first level (see “Unlocking Analyzer Using Security Code” on page 26), the unit will remain unlocked until a positive action is taken to lock the unit again (see “Locking Analyzer Using Security Code” on page 26).

However, when the unit is unlocked by using the bL entry at the second level of security (see “Unlocking Basic Setup Entries (bL)” on page 46), it will remain unlocked only as long as any of the Basic Setup Entries are being accessed. As soon as the Analyzer defaults to the current measurement value, the second level of security automatically locks again, so an unlock procedure is required to reaccess the Basic Setup Entries.

Unlocking Analyzer Using Security Code

1. Press **Lock**. Display will read “Loc”.
2. Press **Next** and then use the **Next** and increment (Δ) keys until the security code is displayed (0800 from factory).
3. Press **Enter**. Analyzer will read uLoc, indicating unlocked state.

Locking Analyzer Using Security Code

1. Press **Lock**. Display will read uLoc.
2. Press **Next** and then use the **Next** and increment (Δ) keys until security code is displayed (0800 from factory).
3. Press **Enter**. Analyzer will read Loc, indicating locked state.

Configuration Setup Entries

The configuration setup entries consist of 19 parameters. These parameters are process oriented and access to them is passcode protected. Table 4 lists each parameter, with its applicable symbol, in the same sequence as seen on the display. Descriptions of each parameter are given in the following text.

Table 4. Configuration Setup Entries

Displayed Symbol	Reference Page	Parameters and Values Accessed	Factory Default	User Settings
CELL	28	Configuration of Display, Analog Outputs	1013	
Hold	29	Holds and sets the Analog Output Value in Hold	0000	
Cd	31	Compensation and Damping Damping Factor Chemical Temperature Compensation	0001	
HAC	33	H Alarm Configuration Measurement Selection Low/High/Instrument plus Passive/Active State % Hysteresis	1403	
HAtt	35	H Alarm Trigger Time	00.00	
HAFt	35	H Alarm Feed Time	00.00	
HAdL	35	H Alarm Delay Time	00.00	
LAC	37	L Alarm Configuration Measurement Selection Low/High/Instrument plus Passive/Active State % Hysteresis	1203	
LAtt	39	L Alarm Trigger Time	00.00	
LAFt	39	L Alarm Feed Time	00.00	
LAdL	39	L Alarm Delay Time	00.00	
UL	41	User-defined Upper Measurement Limit - Both Cells	20.00	
LL	42	User-defined Lower Measurement Limit - Both Cells	00.00	
UtL	42	User-defined Upper Temperature Limit - Both Cells	100.C	
LtL	42	User-defined Lower Temperature Limit - Both Cells	000.C	
HO1	43	100% Analog Output - Channel 1	20.00	
LO1	43	0% Analog Output - Channel 1	00.00	
HO2	43	100% Analog Output - Channel 2	100.C	
LO2	44	0% Analog Output - Channel 2	000.C	

To change any of the Configuration Setup parameters, use the following procedure:

1. Unlock Analyzer (see “Unlocking Analyzer Using Security Code” on page 26).
2. Press **Shift** and while holding, press **Setup**. Release fingers from both keys.
3. Press **Next** one or more times until the parameter to be changed is displayed
4. Press **Enter**.
5. Use **Next** and Δ until the desired code or value is displayed.
6. Press **Enter**.
7. Lock Analyzer (see “Configuration Setup Entries” on page 26).

— **NOTE** —

To prevent time-out while in the middle of this procedure, press/hold the SHIFT key.

CELL Display and Output Configuration (CELL)

The CELL 4-digit code selects the measurement displayed, the measurements taken (one or two), and configures the analog output assignment. See Table 5.

Digit 1 Configuration:

This digit configures the Analyzer's display, output, and measurement capabilities. The selections are as follows.

Digit

- 1 Cell 1 is displayed. Cell 2 is not in use.
- 2 Cell 2 is displayed. Cell 1 is not in use.
- 3 Cell 1 is displayed. Cell 2 measurement is live. Alarms and outputs can be set for both cells.
- 4 Cell 2 is displayed. Cell 1 measurement is live. Alarms and outputs can be set for both cells.
- 7 Ratio is displayed when the first digit is 7. It is mathematically defined as

$$\frac{\text{Cell 1}}{\text{Cell 2}} \times 100 \text{ (Percent legend illuminated)}$$
- 8 Percent Rejection is displayed when the first digit of this code is 8. Percent Rejection is defined mathematically as

$$\left[1 - \frac{\text{Cell 1}}{\text{Cell 2}} \right] \times 100 \text{ (Percent legend illuminated)}$$

When the Analyzer is configured for dual sensor measurement, (digit one = 3, 4, 7, or 8), the Analyzer works in a switching mode, updating each sensors measurement alternately at a 1.5 second rate. The response time for 90% response is 7 seconds when dual sensors are used.

By contrast, the response time for single sensor use is 3.0 sec for 90% response.

— NOTE

A cell must be configured as a measurement alarm in order for an Alarm or Output to be configured to it successfully.

Digits 3 and 4 Configurations:

The plastic enclosure has only one analog output. Configure Digit 3 (Output 1) to correspond to this output. With the metal enclosure, two output signals are available. Most of the output choices in Table 5 are self-explanatory. The measurement signal can also be scaled logarithmically. Using this approach, the output signal may be expanded in a particular range of measurement.

— NOTE

Contact the application specialists at Invensys Foxboro for additional information regarding the Log output.

Possible combinations for the two outputs include:

- ◆ Resistivity and Temperature Sensor 1

- ◆ Resistivity Sensor 1 and Resistivity Sensor 2
- ◆ Ratio Measurement and Temperature
- ◆ % Rejection and Resistivity Sensor 1

For specific information on sensor setup, see Section 7, User Notes.

Table 5. CELL Code - Display and Output Configuration

Digit 1	Digit 2	Digit 3	Digit 4
Measurement And Display	Not Used	Output 1	Output 2
1- Measures and displays Cell 1 only	Digit 2 is not used and should be set at zero.	1-Resistivity Cell 1	1-Resistivity Cell 1
2- Measures and displays Cell 2 only		2-Resistivity Cell 2	2-Resistivity Cell 2
3- Measures Cell 1 and Cell 2 Displays Cell 1		3-Temp Cell 1	3-Temp Cell 1
4- Measures Cell 1 and Cell 2 Displays Cell 2		4-Temp Cell 2	4-Temp Cell 2
7- Ratio		5-Log (resistivity Cell 1)	5-Log (resistivity Cell 1)
8- % Rejection		6-Log (resistivity Cell 2)	6-Log (resistivity Cell 2)
		7-Ratio	7-Ratio
		8-% Rejection	8-% Rejection

Holding the Analog Output (Hold)

The 4-digit code, Hold, is used to freeze the output(s) and alarms to a particular value. The selections are shown in Table 6. When the first digit of this code is 1, 2, or 3, the display flashes between the word “Hold” and the present measurement value. The outputs are frozen at a value corresponding to a % of the analog output range. This percentage is set by the last three digits of the Hold code. While in one of the Hold modes, the Analyzer will continue to monitor and display the value the sensor observes. The sensor may be cleaned or replaced and the unit calibrated while in this mode. An additional use of HOLD permits the output to be simulated to check recorder or controller settings.

If an alarm is configured as a High, Low, or Instrument alarm (HAC, or LAC; 2nd digit in code a 1-6), the alarm status while in the Hold mode may be chosen by the first digit in the Hold code.

If, for instance, an alarm is configured as a Hold alarm (HAC or LAC; 2nd digit a 7 or 8), the alarm will trigger when the Hold is activated. This feature will allow a control room or alarm device (light, bell, etc.) to know the Analyzer is in a Hold mode, not a “RUN” mode. The ALARM will be activated when Hold is implemented when the first digit in the Hold code is changed from 0 to 1, 2, or 3.

Example 1: Hold at a Percent of the Analog Output

For an Analog output of 4 to 20 mA, 50% (050) will always equal 12 mA, and 0% will equal 4 mA.

Or, to Hold on the value being displayed at the present time, the value displayed must be converted to a percent value by the following equation:

$$\frac{(\text{Value displayed} - \text{LO1})}{\text{HO1} - \text{LO1}} \times 100$$

Example 2: Hold at the value presently read on the display

The presently displayed value for Cell 1 is 17 MΩ•cm. HO1 is set at 18.5 MΩ•cm, LO1 is set at 12 MΩ•cm. To set Hold at 17, the last 2 digits of Hold must be 77.

$$\frac{17 - 12}{18.5 - 12} \times 100 = \frac{5}{6.5} \times 100 = 77$$

The Hold Code should read 1077, 2077, or 3077 as applicable. See “Output #1's 100% Analog Value (HO1)” on page 43 and “Output #1's 0% Analog Value (LO1)” on page 43 for a description of HO1 and LO1.

If two outputs are present, both will Hold at 77% (077) of their analog output ranges.

Table 6. Hold Code - Hold Analog Output and Alarms

Digit 1	Digits 2, 3, and 4
Hold Status	Output Range
0 - No Hold	000 to 100% of Analog Output Range
Hold ON, Analog Output on Hold	
1 - Alarms held in present state	
2 - Alarms held with relay not activated	
3 - Alarms held with relay activated	

Compensation and Damping (Cd)

Cd consists of a 4-digit code that selects the type of temperature compensation desired and the amount of damping applied to the measurement. Damping time refers to an interval over which all measurement readings are averaged. Damping affects the measurement and temperature displayed and the analog outputs also. There are two possibilities to use for temperature compensation. Absolute (Digit 4 = 0) does not include temperature compensation. The measurement displayed will include contributions from contaminants as well as temperature. The Ultrapure water correction applies a temperature correction to 25°C based upon the ultrapure water characteristics at 18.2 MΩ•cm and increasing contributions from a contaminant (NaCl assumed) as the resistivity decreases. The code selections are shown in Table 7.

Table 7. Cd Code - Compensation and Damping

Digit 1	Digit 2	Digit 3	Digit 4
Damping	Not Used	Not Used	Temperature Compensation
0 = none 1 = 10 second 2 = 20 second 3 = 40 second 4 = 80 second 5 = 160 second	Enter 0	Enter 0	0 = Absolute (no compensation) 1 = Ultrapure water temperature correction applied. MΩ•cm resistivity is referenced to 25°C

General Information Alarms

Dual independent, Form C dry alarm contacts, rated at 3A noninductive (5A on General Purpose panel-mounted instrument), 125 V ac/30 V dc are provided. The alarm status and measurement are alternately displayed on the LED display. Alarms are set using a code for low, high, hold, or instrument watchdog alarms, with active or passive relays, having a deadband or time delay. Wiring information for the alarms may be found in “Wiring of Plastic Enclosure” on page 16 and “Wiring of Metal Enclosure” on page 17 of this instruction.

— CAUTION —

When the contacts are used at signal levels of less than 20 W, contact function may become unreliable over time due to the formation of an oxide layer on the contacts. See “Alarm Contact Maintenance” on page 83.

— NOTE —

1. Alarms will have to be reset if any changes are made to FSC.
2. Upon powering the Analyzer, the alarm operation is delayed for a time period proportional to the amount of damping set in the Cd code. The alarms remain “OFF” until this measurement has stabilized.

Check that the alarm is configured as desired. Refer to “H Alarm Configuration (HAC)” on page 33 and “L Alarm Configuration (LAC)” on page 37.

Configured Passive – When activated, relay is energized and local display indicates alarm state.

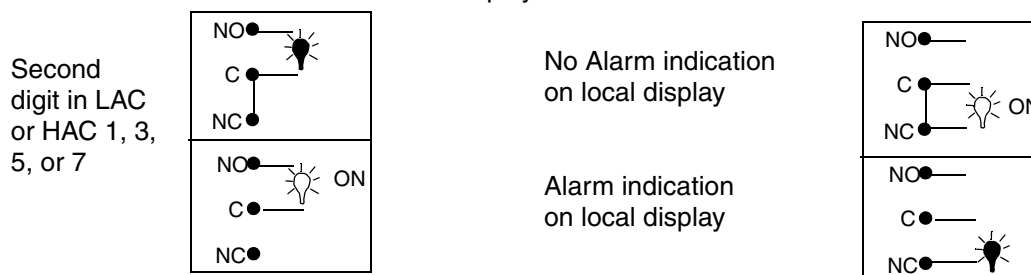

Configured Active – When activated, relay is not energized and local display indicates alarm state.

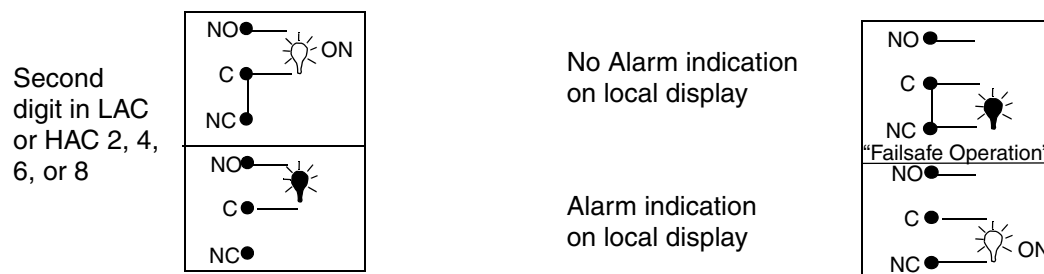

Figure 13. Possible Alarm Wiring and Configuration Choices

Setting Alarm Level(s)

— **NOTE** —

This procedure is relevant only when the alarms are configured as measurement Low and/or High Alarms. When the alarms are configured as Watchdog or Hold alarms, alarm level settings have no relevance.

1. Unlock Analyzer (see “Unlocking Analyzer Using Security Code” on page 26).
2. To set high alarm, press **H Alm**. Then use **Next** and Δ to achieve the desired value on the display.
3. Press **Enter**.
4. To set low alarm, press **L Alm**. Then use **Next** and Δ to achieve the desired value on the display.
5. Press **Enter**.
6. Lock Analyzer (see “Locking Analyzer Using Security Code” on page 26).

— **NOTE** —

If alarms are not desired, set the H Alm and L Alm values outside the normal measurement range.

H Alarm Configuration (HAC)

The HAC 4-digit code configures the alarm designated as “H Alm.” See Table 8 on page 34. There are three configurable parameters associated with each alarm. The first digit of this code allows the alarm to be configured to correspond to one of six alarm measurement selections. The second digit of this code configures the alarm as a Measurement alarm, Instrument alarm, or Hold alarm. The third and fourth digits set the alarm hysteresis (deadband). This parameter is associated with the alarms used as measurement alarms. The deadband may be varied from 0 to 99% of the FSC range in increments of 1%.

When used as a measurement alarm, four configurations are possible. These are as a low passive or active, or a high passive or active alarm, i.e., digit 2 is 1-4.

A low alarm relay will trip on decreasing measurement.

A high alarm relay will trip on increasing measurement.

Passive or active (failsafe) configurations are also chosen by this digit choice. In the active (failsafe) configuration, a loss of power to the Analyzer causes a change from active to passive relay state, providing contact closure and an indication of a power problem. Correct wiring of the contacts is necessary for true failsafe operation. Consult “Wiring of Plastic Enclosure” on page 16 and “Wiring of Metal Enclosure” on page 17 of this document for wiring information. Also see Figure 13 on page 32.

As an alternative to a measurement alarm, the H alarm may be used as an Instrument Alarm. In this “Watchdog” state, the alarm can communicate any diagnostic error present in the system. When used as a diagnostic alarm, the H alarm cannot be used as a conventional measurement alarm. However, since one of the configurable diagnostic parameters is “measurement error,” the H alarm, when programmed properly, can report either diagnostic or measurement problems. Set digit 2 in this code as either 5 or 6, as applicable.

When the H alarm is configured as a diagnostic error communicator, it will report any system problem. It cannot selectively report a given problem, however. The type of hardware/software conditions that will cause an alarm include:

- ◆ A/D converter error
- ◆ EEPROM checksum error
- ◆ RAM error
- ◆ ROM error
- ◆ Processor task time error (watchdog timer)

Additionally, the user may program several temperature and measurement error limits that, if exceeded, will cause an alarm condition. These programming options are explained in “User-Defined Upper Temperature Limit (UtL)” on page 42 and “User-Defined Lower Temperature Limit (LtL)” on page 42.

Refer to the “Error Codes” on page 72 for identifying error messages.

The H alarm may also be configured and used as a Hold alarm. When used as a Hold alarm, the H alarm cannot be used as a conventional measurement alarm. When the alarm is configured as a HOLD alarm (HAC; 2nd digit a 7 or 8), the alarm will trigger when the Hold is activated. This feature will allow a control room or alarm device (light, bell, etc.) to know the Analyzer is in a

Hold mode, not a “RUN” mode. The ALARM will be activated when Hold is implemented when the first digit in the Hold code is 1, 2, or 3.

— NOTE —

The cell must be configured in a measurement state for the alarm to be configured and operative. If an unused cell in the single cell mode is configured to the alarm, the alarm will be inoperative (frozen at 4 mA). Verify that the cell code is set appropriately. See “CELL Display and Output Configuration (CELL)” on page 28.

Table 8. HAC Code - High Alarm Configuration

Digit 1	Digit 2	Digits 3 and 4
H ALARM SELECTION	CONFIGURATION	HYSTERESIS
1 - Meas Cell 1 2 - Meas Cell 2 3 - Temp Cell 1 4 - Temp Cell 2 7 - % Ratio 8 - % Rejection	1 = Low/Passive 2 = Low/Active 3 = High/Passive 4 = High/Active 5 = Instrument/Passive 6 = Instrument/Active 7 = Hold/Passive 8 = Hold/Active	00 to 99% of Full Scale

Alarm Timers (HAtt, HAFt and HAdL)

There are three timers associated with the H Alarm:

1. *HAtt (H Alarm Trigger Time)*
Programmable timer to prevent alarm from triggering unless the measurement remains in the alarm state for a user-defined period of time.
2. *HAFt (H Alarm Feed Time)*
Programmable timer to keep alarm ON for a user-defined period of time once it has been tripped.
3. *HAdL (H Alarm Delay Time)*
Programmable timer to keep the alarm OFF for a user-defined period of time once the HAFt time has expired.

Each of these timers will be explained fully in the following paragraphs and their relationships illustrated in Figure 14 and the flow diagram in Figure 15.

H Alarm Trigger Timer (HAtt) may be used with or without the other alarm timers (HAFt and HAdL). HAtt is used when H Alarm is configured as a *measurement* alarm only. The purpose of this timer is to prevent the alarm from activating due to transient conditions such as air bubbles or other spikes. After the timer has counted down, that alarm will activate *only* if the measurement has remained in an alarm state during the *entire* trigger time. HAtt resets any time the measurement passes through the alarm set point. Table 9 on page 35 shows the code designation.

H Alarm Feed Time (HAFt) is activated by entering a time in the code parameter HAFt. When the H Alarm is triggered, the alarm will remain ON for this time period regardless of what the measurement value is with respect to the alarm set point (i.e., H Alarm will remain ON even if the measurement returns to normal). Table 9 shows the code designation.

H Alarm Delay Time (HAdL) is activated by entering a time in the code parameter HAdL. Upon time-out of HAFt, the alarm will stay OFF for this time period regardless of what the measurement value is with respect to the alarm set point (the H Alarm will remain OFF even if the measurement goes back into alarm). Table 9 shows the code designation.

Table 9. HAtt, HAFt, and HAdL Time Codes

Digits 1 and 2	Digit 3	Digit 4
00 to 99 minutes	0 to 9 tenths of minutes	0 to 9 hundredths of minutes

Examples:

- 05.15 means 5 minutes, 9 seconds
- 20.50 means 20 minutes, 30 seconds

After time-out of HAdL, the 873 reverts to normal run mode. If the measurement has remained in an alarm state for the entire period (HAFt + HAdL), the sequence of HAFt and HAdL repeats itself. If, however, the measurement has gone out of alarm at any time during the cycle, it must remain in alarm for the trigger time before reactivating the cycle.

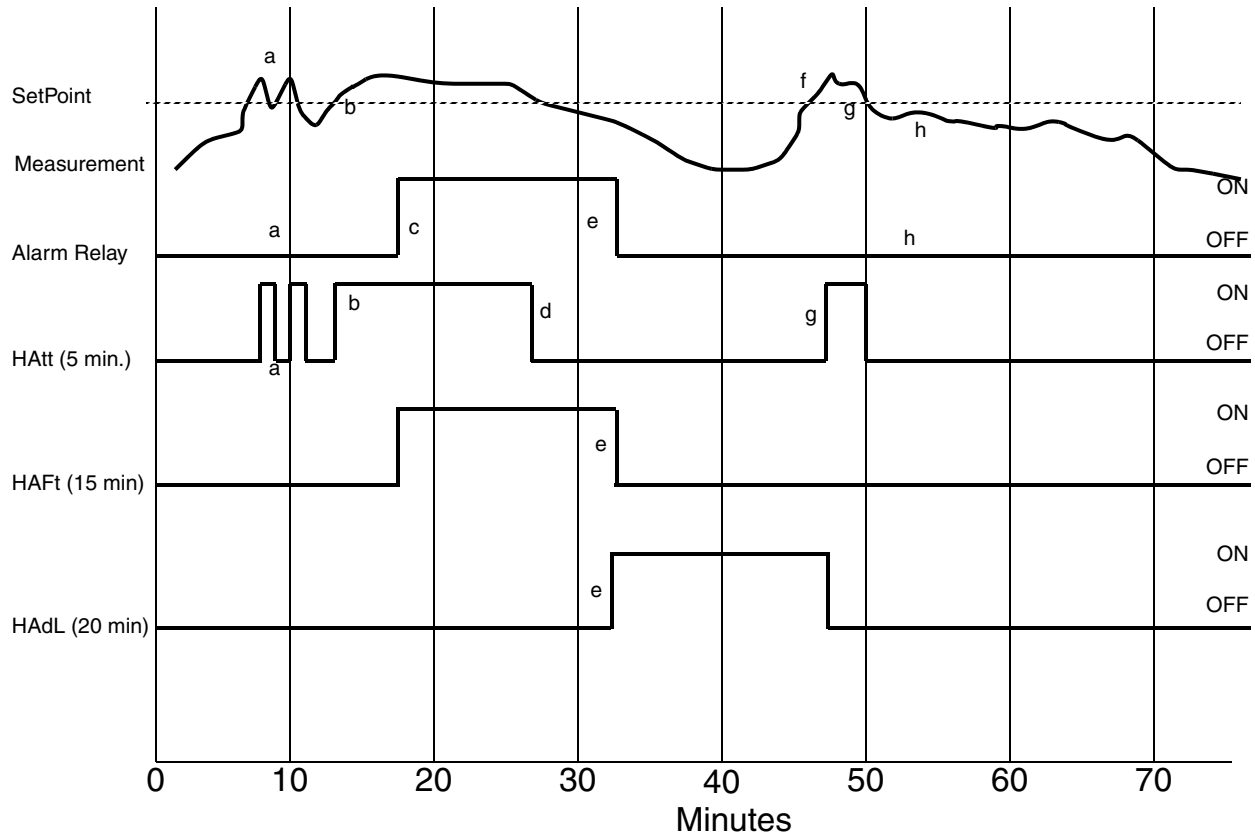

Figure 14. ON/OFF Relationship between HAtt, HAFt and HAdL

The following explanatory notes coupled with the illustration above should serve to demonstrate the function of the three 873 Analyzer timers.

- a. Measurement exceeds set point but does not remain above set point for the time period set in HAtt (5 minutes). Alarm relay remains inactive. Note that HAtt resets when the measurement falls below set point.
- b. Measurement exceeds set point once again, activating HAtt, and remains continuously above set point for the time period set in HAtt (5 minutes).
- c. After measurement has remained above set point for the entire trigger time (5 minutes), the alarm relay is activated.
- d. HAtt is reset when measurement falls below set point once again. Note that the alarm relay remains activated despite the fact that the measurement has fallen below the set point. The alarm relay will remain activated for the time period set in HAFt (15 minutes).
- e. After the alarm relay has been activated for the feed time (15 minutes), HAFt times out and the alarm relay is deactivated. The alarm relay will remain deactivated for the time period set in HAdL (20 minutes).
- f. Measurement exceeds set point, but the alarm relay remains deactivated because the delay time (20 minutes) has not expired.

- g. After the delay time has expired, the measurement is still in alarm, so HAtt is activated.
- h. The measurement drops below set point before the trigger time (5 minutes) expires, so the alarm relay does not activate and HAtt is reset.

The following flow diagram should also serve to illustrate the logic of the three alarm timers:

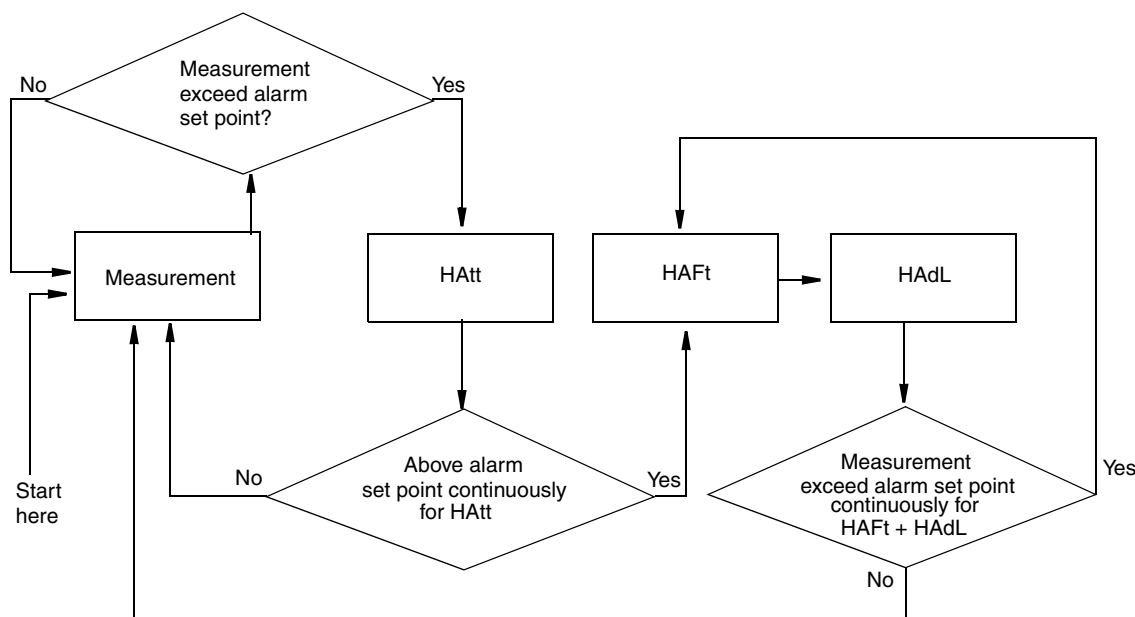

Figure 15. Flow Diagram for Alarm Timer Logic

L Alarm Configuration (LAC)

The LAC 4-digit code configures the L alarm. See Table 10 on page 38. Three configurable parameters are associated with this alarm. The first digit of this code allows the alarm to be configured to correspond to one of six alarm measurement selections. The second digit of the code configures the alarm as a Measurement alarm, Instrument alarm, or Hold alarm.

The third and fourth digits set the alarm hysteresis (deadband). This parameter is associated with the alarm when used as a measurement alarm. The deadband may be varied from 0 to 99% of FSC range chosen in increments of 1%.

When used as a measurement alarm, four configurations are possible. These are as a low passive or active, or a high passive or active alarm. Set digit 2 as 1-4, as applicable.

A low alarm relay will trip on decreasing measurement.

A high alarm relay will trip on increasing measurement.

Passive or active (failsafe) configurations are also chosen by this digit choice. In the active (failsafe) configuration, a loss of power to the Analyzer will result in a change from active to passive relay state, providing contact closure and an indication of a power problem. Correct wiring of the contacts is necessary for true failsafe operation. Consult "Wiring of Plastic Enclosure" on page 16 and "Wiring of Metal Enclosure" on page 17 of this document for wiring information. Also see Figure 13 on page 32.

Alternative to a measurement alarm, the L alarm may be used as an Instrument Alarm. In this “Watchdog” state, the alarm can communicate any diagnostic error present in the system. When used as a diagnostic alarm, the L alarm cannot be used as a conventional measurement alarm. However, since one of the configurable diagnostic parameters is “measurement error,” the L alarm, when properly programmed, can report either diagnostic or measurement problems. Set digit 2 in this code as either a 5 or 6, as applicable.

When the L alarm is configured as a diagnostic error communicator, it will report any system problem. It cannot selectively report a given problem. The type of hardware/software conditions that will cause an alarm include:

- ◆ A/D converter error
- ◆ EEPROM checksum error
- ◆ RAM error
- ◆ ROM error
- ◆ Processor task time error (watchdog timer)

Additionally, the user may program several temperature and measurement error limits which, if exceeded, will cause an alarm condition. These programming options are explained in “User-Defined Upper Temperature Limit (UtL)” on page 42 and “User-Defined Lower Temperature Limit (LtL)” on page 42.

Refer to the “Error Codes” on page 72, for identifying error messages.

The L alarm may also be configured and used as a Hold alarm. When used as a Hold alarm, the L alarm cannot be used as a conventional measurement alarm. When the L alarm is configured as a Hold alarm (LAC; 2nd digit a 7 or 8), the alarm will trigger when the Hold is activated. This feature will allow a control room or alarm device (light, bell, etc.) to know the Analyzer is in a Hold mode, not a “RUN” mode. The ALARM will be activated when Hold is implemented when the first digit in the Hold code is 1, 2, or 3.

— **NOTE** —

Configuration of the alarm to a cell not in a measurement state will result in non-operation of the alarm. Verify cell code is set appropriately. See “CELL Display and Output Configuration (CELL)” on page 28.

Table 10. LAC Code - Low Alarm Configuration

Digit 1	Digit 2	Digits 3 and 4
L ALARM SELECTION	CONFIGURATION	HYSTERESIS
1 - Meas Cell 1	1 = Low/Passive	00 to 99% of Full Scale
2 - Meas Cell 2	2 = Low/Active	
3 - Temp Cell 1	3 = High/Passive	
4 - Temp Cell 2	4 = High/Active	
7 - % Ratio	5 = Instrument/Passive	
8 - % Rejection	6 = Instrument/Active	
	7 = Hold/Passive	
	8 = Hold/Active	

Alarm Timers (LAtt, LAFt, and LAdL)

There are three timers associated with the L Alarm:

1. *LAtt (L Alarm Trigger Time)*
Programmable timer to prevent alarm from triggering unless the measurement *remains in the alarm state for a user-defined period of time.*
2. *LAFt (L Alarm Feed Time)*
Programmable timer to keep alarm ON for a user-defined period of time once it has been tripped.
3. *LAdL (L Alarm Delay Time)*
Programmable timer to keep the alarm OFF for a user-defined period of time once the LAFt time has expired.

Each of these timers will be explained fully in the following paragraphs and their relationships illustrated in Figure 16 and the flow diagram in Figure 17 on page 41.

L Alarm Trigger Timer (LAtt) may be used with or without the other alarm timers (LAFt and LAdL). LAtt is used when L Alarm is configured as a *measurement* alarm only. The purpose of this timer is to prevent the alarm from activating due to transient conditions such as air bubbles or other spikes. After the timer has counted down, that alarm will activate *only* if the measurement has remained in an alarm state during the *entire* trigger time. LAtt resets any time the measurement passes through the alarm set point. Table 11 shows the code designation.

L Alarm Feed Time (LAFt) is activated by entering a time in the code parameter LAFt. When the L Alarm is triggered, the alarm will remain ON for this time period regardless of what the measurement value is with respect to the alarm set point (i.e., L Alarm will remain ON even if the measurement returns to normal). Table 11 shows the code designation.

L Alarm Delay Time (LAdL) is activated by entering a time in the code parameter LAdL. Upon time-out of LAFt, the alarm will stay OFF for this time period regardless of what the measurement value is with respect to the alarm set point (i.e., L Alarm will remain OFF even if the measurement goes back into alarm). Table 11 shows the code designation.

Table 11. LAtt, LAFt, and LAdL Time Codes

Digits 1 and 2	Digit 3	Digit 4
00 to 99 minutes	0 to 9 tenths of minutes	0 to 9 hundredths of minutes

Examples:

- 05.15 means 5 minutes, 9 seconds
- 20.50 means 20 minutes, 30 seconds

After time-out of LAdL, the 873 reverts to normal run mode. If the measurement has remained in an alarm state for the entire period (LAFt + LAdL), the sequence of LAFt and LAdL repeats itself. If, however, the measurement has gone out of alarm at any time during the cycle, it must remain in alarm for the trigger time before reactivating the cycle.

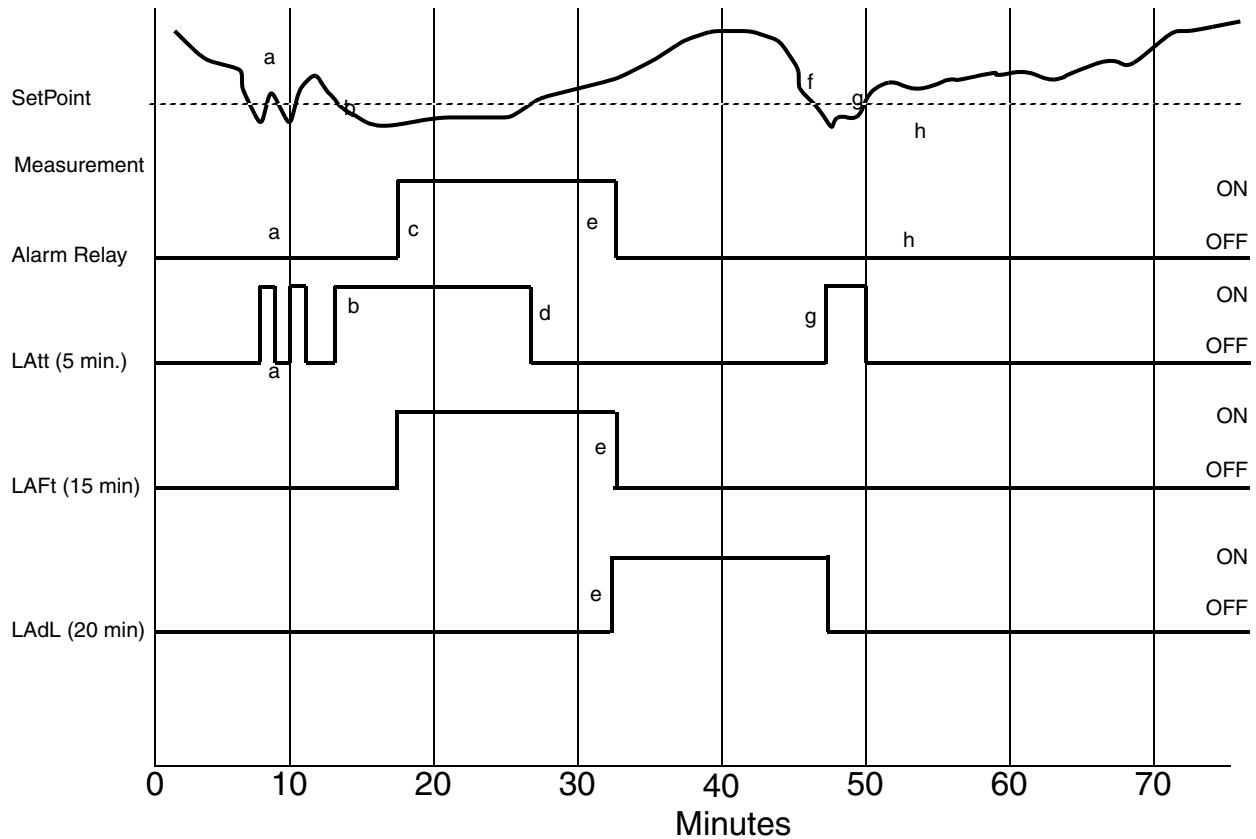

Figure 16. ON/OFF Relationship between LAtt, LAFt, and LAdL

The following explanatory notes coupled with the illustration above demonstrate the functions of the three 873 Analyzer timers.

- a. Measurement drops below set point but does not remain below set point for the time period set in LAtt (5 minutes). Alarm relay remains inactive. Note that LAtt resets when the measurement rises above set point.
- b. Measurement drops below set point once again, activating LAtt, and remains continuously below set point for the time period set in LAtt (5 minutes).
- c. After measurement has remained below set point for the entire trigger time (5 minutes), the alarm relay is activated.
- d. LAtt is reset when measurement rises above set point once again. Note that the alarm relay remains activated despite the fact that the measurement has risen above the set point. The alarm relay will remain activated for the time period set in LAFt (15 minutes).
- e. After the alarm relay has been activated for the feed time (15 minutes), LAFt times out and the alarm relay is deactivated. The alarm relay will remain deactivated for the time period set in LAdL (20 minutes).
- f. Measurement drops below set point, but the alarm relay remains deactivated because the delay time (20 minutes) has not expired.

- g. After the delay time has expired, the measurement is still in alarm, so LAtt is activated.
- h. The measurement rises above set point before the trigger time (5 minutes) expires, so the alarm relay does not activate and LAtt is reset.

The following flow diagram should also serve to illustrate the logic of the three alarm timers:

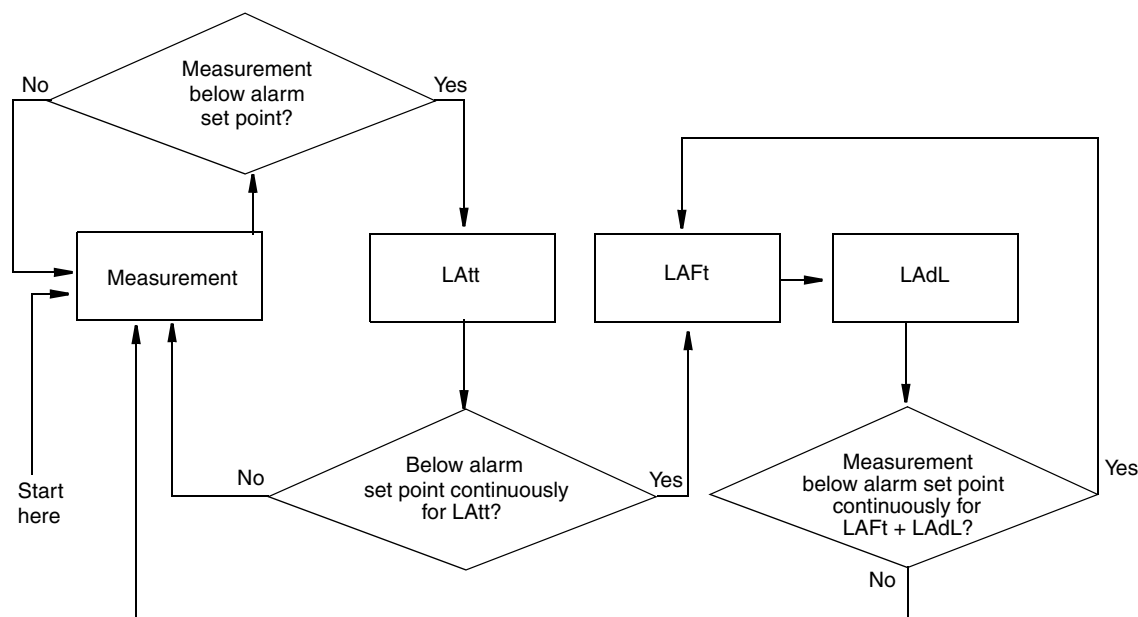

Figure 17. Flow Diagram for Alarm Timer Logic

User-Defined Upper Measurement Limit (UL)

This enables the user to define an upper measurement limit which, if exceeded, will give an error message on the display (see “Error Codes” on page 72), and when used with either alarm configured as an instrument (watchdog) alarm (HAC or LAC digit 2 is 5 or 6), provides a relay contact. The value set by this code defines the measurement limit for *both* cells.

UL is primarily used as a sensor diagnostic tool. If the 871CC sensor develops a fault, such as leakage between the electrodes or a broken or intermittent lead wire, the measurement signal sent to the 873 Analyzer will be unreasonably low or high. By setting UL at a value that could never be achieved in a normal process situation, such as 19 MΩ•cm, activation of a UL alarm indicates either a severe sensor failure or miscalibration. The upper limit of UL is 99.99 MΩ•cm.

— NOTE

Invensys Foxboro preconfigures UL to a value equal to the specified full scale measurement per Sales Order.

User-Defined Lower Measurement Limit (LL)

The LL parameter is similar to the previously described UL parameter, except that it allows programming of a lower measurement limit. In an ultrapure water measurement application, a value of 0 M Ω •cm is a good choice for LL, since ultrapure water could never actually reach a resistivity value as low as 0. The lower limit on LL is $-.999$ M Ω •cm (decimal point will move with the FSC range used). The value set by this parameter is related to *both* measurement cells.

— NOTE

To make a minus sign appear on the display requires a digit other than zero to be present on the display

Example:

To make the display read $-.99$, first display 0.99, then change the first digit to a negative sign.

User-Defined Upper Temperature Limit (UtL)

This parameter enables the user to define an upper temperature measurement value which, if exceeded, gives an E3 message on the display (see “Error Codes” on page 72). When used in conjunction with the configurable alarms (HAC or LAC digit 2 is 5 or 6), it provides a relay contact.

UtL is primarily used as a sensor diagnostic tool. If the RTD or thermistor in the 871CC sensor develops a fault, the instrument may produce erroneous temperature readings at either extreme of the temperature scale. By setting UtL at a temperature outside any conceivable process temperature, an alarm indicates a problem with the 871CC sensor temperature transducer. The upper limit of UtL is 200°C or 392°F.

The value set for this parameter defines the limit for both sensors (if installed).

User-Defined Lower Temperature Limit (LtL)

This parameter is similar to the previously described UtL parameter, except that it allows programming of a *lower* temperature measurement limit. The lower limit on LtL is -20°C or -5°F . Invensys Foxboro preconfigures the LtL value to be 0°C . The value set for this parameter defines the limit for both sensors (if installed).

— NOTE

To make a minus sign appear on the display requires that a digit other than zero be present on the display. Example: To make the display read -20°C , first display 020°C , then change the first digit to a negative sign.

Scaling Analog Outputs

Each 873RS Analyzer has either one or two analog output signals as standard. Each output signal is linearly proportional to the measured variable (except when the output(s) is (are) configured as logarithmic. (Refer to “CELL Display and Output Configuration (CELL)” on page 28).

Both analog output signals may be scaled so as to improve sensitivity of the analog output within the range of interest. The outputs can be scaled as forward or reverse acting. The output configuration will be ignored, frozen at 4mA, if the CELL code is not configured properly. If an

output is to be configured to a cell, the cell must be in an active measurement state. See “CELL Display and Output Configuration (CELL)” on page 28.

The maximum output span that should be set on the Analyzer is the FSC value. The minimum output span that should be set on the Analyzer is 10% of the FSC value. Although it is physically possible to set the Analyzer for a smaller span, a loss of accuracy is possible. The analog output could develop steps instead of following the measurement in a continuum.

— **NOTE** —

The analog outputs should be configured after the FSC and Cd parameters have been set.

Output #1's 100% Analog Value (H01)

This 4-digit code may be set to any value between -0.99 and 99.99. The value set by this code will correspond to 100% of the analog output (20 mA or 10 volts), depending upon output ordered.

Example:

Output 1 has been configured to correspond to the resistivity of Cell 1 (CELL Code 1013). You want 20 mA to correspond to 15 MΩ•cm. Once in H01 mode, use **Next** and Δ to display the correct value 15.00 MΩ•cm. Press **Enter**. The correct units will appear if CELL was configured properly.

Output #1's 0% Analog Value (L01)

This 4-digit code may be set to any value between -0.99 and 99.99. The value set by this code will correspond to 0% of the analog output, that is, 0 mA, 4 mA, or 0 V, depending upon the output configuration. The value may be greater than H01 if desired. The L01 value is tied to CELL code digit 3.

Example:

Output 1 has been configured to correspond to the resistivity of Cell 1 (CELL Code 1013). You want 4 mA to correspond to 5.00 MΩ•cm. Once in L01 mode, use **Next** and Δ to display 5.00 MΩ•cm. Press **Enter**. The correct units will appear if CELL was configured properly.

Output #2's 100% Analog Value (H02)

— **NOTE** —

Only use on metal units; general purpose units use H01.

H02 configures the second output to 100% of the analog output. The parameter is similar to H01. The H02 value ties to CELL code digit 4.

Example:

Output 2 has been configured to correspond to the temperature transducer of Cell 1 (CELL Code 1013). You wish to have 20 mA correspond to 30°C. Once in H02 mode, use **Next** and Δ to display 30°C. Press **Enter**. The correct units will appear if CELL was configured properly.

Output #2's 0% Analog Value (L02)

— NOTE

Only use on metal units; general purpose units use L01.

L02 configures the second output to 0% of the analog output. This parameter is similar to L01. The L02 value ties to CELL code digit 4.

Example:

Output 2 has been configured to correspond to the temperature transducer of Cell 1 (CELL Code 1013). You wish to have 4 mA correspond to 100°C. Once in L02 mode, use **Next** and Δ to display 100°C. Press **Enter**. The correct units will appear if CELL was configured properly.

Basic Setup Entries

The Basic Setup entries consist of 19 configurable parameters. These parameters are calibration oriented and access to them has two levels of passcode protection. Changes to most of these parameters require the Analyzer to be recalibrated. DO NOT make any changes before reading the following text for each parameter.

Table 12 lists all parameters, with applicable symbols, in the same sequence as seen on the display. Descriptions of the procedures that use these parameters (Unlocking Basic Setup Entries, Changing the Full Scale Range, Changing the Temperature Circuitry, Changing the Analog Output, and Changing the Security Code) follow the table.

Table 12. Basic Setup Entry Selection

Display Symbol	Reference	Parameter and Value Accessed	Factory Default	User Settings
bL	46	Basic Setup Lock Control	0800	
FSC	46	Full Scale Value	20.00	
CF1	65	Cell Factor - Cell 1	1000	
tCF1	65	Temperature Cell Factor - Cell 1	25.00	
tEC1	50	Thermistor Temperature Electronics Calibration Cell 1	25.00	
tCL1	51	RTD Low Temperature Electronics Calibration Cell 1	100.0	
tCC1	51	RTD Mid Temperature Electronics Calibration Cell 1	150.0	
tCH1	51	RTD High Temperature Electronics Calibration Cell 1	200.0	
LCC	57	Lock Code Change	0800	
CF2	65	Cell Factor - Cell 2	1000	
tCF2	65	Temperature Cel Factor - Cell 2	25.00	
tEC2	50	Temperature Channel Electronics Calibration Cell 2	25.00	
tCL2	51	RTD Low Temperature Electronics Calibration Cell 2	100.0	
tCC2	51	RTD Mid Temperature Electronics Calibration Cell 2	150.0	
tCH2	51	RTD High Temperature Electronics Calibration Cell 2	200.0	
LCO1	53	Analog Out 1 Electronics Lower Calibration	00.00	
HCO1	53	Analog Out 1 Electronics Upper Calibration	100.0	
LCO2	53	Analog Out 2 Electronics Lower Calibration	00.00	
HCO2	53	Analog Out 2 Electronics Upper Calibration	100.0	
SFt		Software Version Number		
SOH		Sales Order High		
SOL		Sales Order Low		

Unlocking Basic Setup Entries (bL)

To change any of the Basic Setup Entries, use the following procedure.

— **NOTE** —

To avoid “timing out” on any display, press/hold **Shift**.

1. Unlock Analyzer at the first security level (see “Unlocking Analyzer Using Security Code” on page 26).
2. Press **Shift** and while holding, press **Setup**. Release finger from both keys.
3. Press **Next** nineteen times until bL is displayed.
4. Press **Enter**. LOC appears on the display.
5. Press **Next**.
6. Use **Next** and Δ repeatedly until the security code is displayed (0800 from factory).
7. Press **Enter**. ULOC appears on the display.
8. When display returns to bL, press **Next** one or more times until parameter to be changed appears on the display.
9. Press **Enter**.
10. Use **Next** and Δ repeatedly until the desired value is displayed.
11. Press **Enter**.
12. When display defaults to the current measurement value, the Analyzer is automatically locked at the second level (bL) of security.
13. Lock Analyzer (see “Locking Analyzer Using Security Code” on page 26).

Changing the Full Scale Range (FSC)

This parameter allows the user to select one of five possible ranges to monitor the process. The ranges are 0 to 2.000 M Ω •cm, 0 to 5.000 M Ω •cm, 0 to 10.00 M Ω •cm, 0 to 15.00 M Ω •cm, and 0 to 20.00 M Ω •cm. The Analyzer accuracy is .5% of the measurement range value chosen when calibrated with precision resistors with 0.1% accuracy. Thus, for best accuracy, the FSC value should be set as low as possible while still allowing all measurement values to fall within its span.

On the lower ranges, the Analyzer displays values to the thousandths place.

—  **CAUTION** —

1. When changing ranges, the drive voltage to the sensor inputs is changed. Altering the FSC range via the keypad will require the unit to be bench calibrated before use.
 2. Pressing **Enter** in FSC mode (even if range was not changed) will require the unit to be bench calibrated before use. If the range is set at a range you require, allow unit to time out. Do not press **Enter**.
 3. After changing FSC, Configuration Setup Entries should be checked and altered, if necessary.
-

The Analyzer is capable of displaying values greater than that set by the FSC ranges. For example, when the FSC is on the 0 to 5.000 M Ω •cm range, it can display up to 9.999 M Ω •cm at 25.0°C. Invensys Foxboro preconfigures the FSC value per sales order or at 20.00 M Ω •cm as a default.

The procedure for changing FSC is as follows:

1. Unlock Analyzer (see “Unlocking Analyzer Using Security Code” on page 26).
2. Press/hold **Shift** and while holding, press **Setup**. Release both keys.
3. Press **Next** several times until the code bL (Basic Setup Lock) is displayed (bL will be the nineteenth message to be displayed).
4. Press **Enter**, then press **Next** and Δ repeatedly until personal security code is displayed (0800 from factory).
5. Press **Enter**.
6. When display returns to bL, press **Next**. The code FSC (Full Scale Range Change) will be displayed.
7. Press **Enter**. The present full scale range will be displayed.

— **!** **CAUTION** —

If this is your desired FSC, allow unit to time out. **DO NOT PRESS ENTER.**
 Entering any FSC causes Er4 to flash on the display, necessitating a bench calibration.

8. Press Δ repeatedly until the desired range is displayed.
9. Press **Enter**.
10. Lock Analyzer (see “Locking Analyzer Using Security Code” on page 26).

— **NOTE** —

Calibration is required after full scale range is changed. Error code ER4 flashes until calibration is accomplished. Refer to “Electronic Bench Calibration” on page 59.

Changing the Temperature Circuitry

Temperature Electronics Calibration for either thermistor (tEC1, tEC2) or RTD (tCL1, tCC1 and tCH1 or tCL2, tCC2, and tCH2) type sensors is performed at the factory. It is not necessary to perform these procedures in the field unless:

1. You have switched from RTD type sensors (871CC Series K through M) to thermistor type (871CC Series A through F) or vice versa.
2. You suspect a problem with the temperature calibration.
3. You wish to verify temperature electronics calibration.

— **NOTE** —

The factory calibration of these circuits uses resistors with 0.01% accuracy. Calibration with resistors with less accuracy compromises the stated specifications of this Analyzer.

If switching from an 871CC A through F style sensor (Thermistor) to an 871CC K through M style sensor (RTD) or vice versa, it is necessary to position the jumpers within the Analyzer and perform a recalibration.

This procedure only calibrates the Analyzer. To compensate for sensor cable length, see “Calibrating the Analyzer to a Specific Sensor” on page 65.

To Reposition Jumpers:

! CAUTION

Use proper ESD precautions when opening this instrument for any servicing.

1. Remove power to the unit.
2. On the plastic enclosure: remove optional rear cover. Remove the four screws holding back panel in place.

On the metal enclosure: remove the four front corner screws holding the display panel in place. Remove rear cover. Disconnect the green earth (ground) cable; then feed wire from sensors and power connection through seals to allow free movement of circuit boards.

! CAUTION

The four screws are self-tapping and have a limited grip if repeatedly removed. Do not repeatedly remove and tighten these screws.

3. Slide circuit assembly out to access the upper circuit board designated AS700EA. The plastic enclosure slides out from the rear of its housing. The metal enclosure slides out from the front of its housing.
4. Refer to Figure 18 on page 49 to identify jumper locations.
5. Use Table 13 to locate appropriate jumper positions.

Table 13. Jumper Positions for Temperature Transducer

	Jumper	100 Ω RTD	Thermistor
Cell One	J12	P2 & P3	P1 & P2
	J14	P1 & P2	P2 & P3, P4 & P5
Cell Two	J11	P2 & P3	P1 & P2
	J13	P1 & P2	P2 & P3, P4 & P5

6. Move each jumper to its appropriate position.
7. Replace board assembly inside unit.

! CAUTION

On the plastic enclosure, a string must be rigged through the loop in the ribbon cable such that when the board assembly is slid into the housing, the string/ribbon cable may be pulled back simultaneously, thus preventing damage to the cable. See Figure 18 on page 49.

8. Replace cover. On metal enclosures, use Loctite (Part No. S0106ML) on the threads of the front bezel screws, and Lubriplate (Part No. X0114AT) on the threads of the rear cover screws.
9. If you changed to Thermistor Temperature Compensation, see “Thermistor Temperature Electronic Calibration (tEC1, tEC2)” on page 50 to complete the calibration.
10. If you changed to RTD Temperature Compensation, see “RTD Temperature Calibration (tCL1, tCC1, tCH1, and tCL2, tCC2, tCH2)” on page 51.
11. Make appropriate changes to the Analyzer identification label.

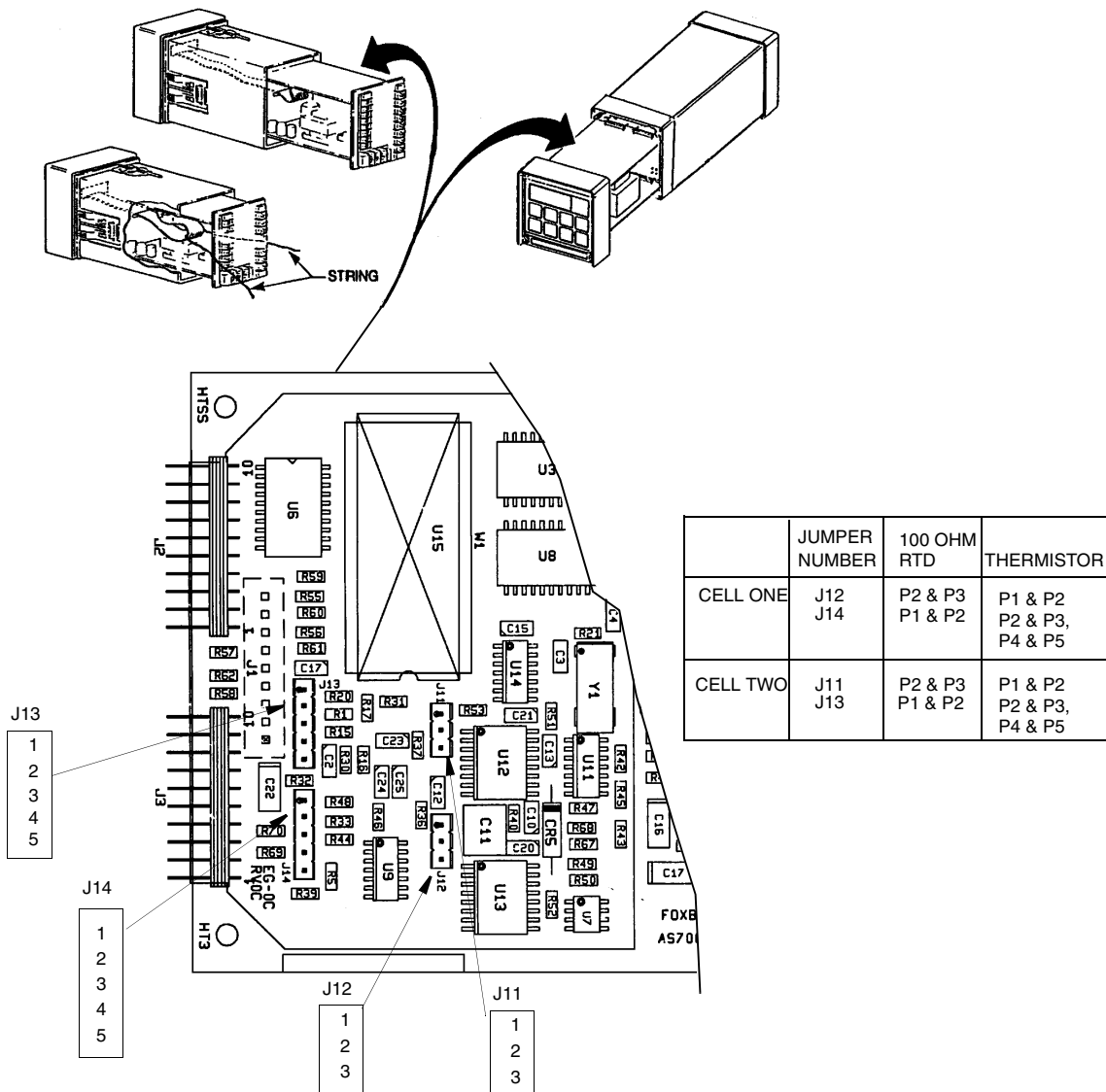

Figure 18. Jumpers for Temperature Compensation

Thermistor Temperature Electronic Calibration (tEC1, tEC2)

— NOTE

Sensor Styles 871CC A-F use 100 k Ω thermistors.

Required: Two 100 k Ω precision resistors with .01% accuracy or better.

1. Disconnect sensor lead connections 3, 3A, 4, and 5 from TB2.
2. Connect two precision 100 k Ω resistors between the sensor terminals:
3 and 3A, and also 4 and 5.
3. Unlock Analyzer using security code.
4. Press **Shift** and while holding, press **Setup**. Release fingers from both keys.
5. Press **Next** several times until the code bL (Basic Lock Setup) is displayed (bL will be the nineteenth message displayed).
6. Press **Enter**, then use **Next** and Δ repeatedly until the personal security code is displayed (0800 from factory).
7. Press **Enter**.
8. When display returns to bL, press **Next** 4 times until tEC1 is displayed.
9. Press **Enter**. The value 25.00 will be displayed.
10. Press **Enter**.
11. When display returns to tEC1, press **Next** seven times until tEC2 is displayed.
12. Press **Enter**. The value 25.00 will be displayed.
13. Press **Enter**.
14. Disconnect 100 k Ω resistors from terminals 3 and 3A. Also 4 and 5.
15. Reconnect sensor leads to 3, 3A, 4, and 5.
16. Lock Analyzer.

This completes the thermistor temperature electronics calibration.

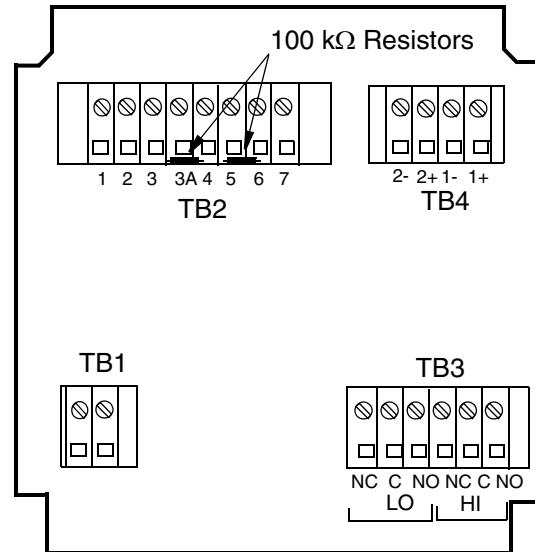

Figure 19. Thermistor Temperature Simulation (Metal Enclosure Shown)

RTD Temperature Calibration (t_{CL1} , t_{CC1} , t_{CH1} , and t_{CL2} , t_{CC2} , t_{CH2})

— **NOTE** —

871CC Sensors Type K-M use 100 Ω RTDs.

Required: two each, 100, 150, and 200 Ω precision resistors with 0.1% accuracy. Decade boxes with cable leads will reduce calibration accuracy.

1. Disconnect sensor lead connections 3, 3A, 4, and 5 from TB2.
2. Connect two 100 Ω precision resistors between terminals:
3 and 3A, also 4 and 5.
3. Unlock Analyzer using security code.
4. Press **Shift** and while holding, press **Setup**. Release fingers from both keys.
5. Press **Next** several times until the code bL (Basic Lock Setup) is displayed.
6. Press **Enter**, then use **Next** and Δ repeatedly until the personal security code is displayed (0800 from factory).
7. Press **Enter**.
8. When display returns to bL, press **Next** five times until t_{CL1} is displayed. Press **Enter**. Then keep finger on **Shift**.
9. Display will show 100.0 ohms. Press **Shift** and hold for 20 seconds, then press **Enter**. Then keep finger on **Shift**.
10. Replace the 100 Ω resistor for cell 1 (leads 3 and 3A) with a 150 Ω precision resistor.
11. Release **Shift** key. When display returns to t_{CL1} , press **Next** once to display t_{CC1} . Press **Enter**.

12. Display will show 150.0 ohms. Press **Shift** and hold for 20 seconds, then press **Enter**. Then keep finger on **Shift**.
 13. Replace the 150 Ω resistor for cell 1 with a 200 Ω precision resistor.
 14. Release **Shift** key. When display returns to tCC1, press **Next** once to display tCH1. Press **Enter**.
 15. Display will show 200 ohms. Press **Shift** and hold for 20 seconds, then press **Enter**.
 16. When display returns to tCH1, press **Next** five times to display tCL2. Press **Enter**.
 17. Display will show 100.0 ohms. Press **Shift** and hold for 20 seconds, then press **Enter**. Keep finger on **Shift**.
 18. Replace the 100 Ω resistor for cell 2 with a 150 Ω precision resistor.
 19. Release **Shift** key. When display returns to tCL2, press **Next** once to display tCC2. Press **Enter**.
 20. Display will show 150.0 ohms. Press **Shift** and hold for 20 seconds, then press **Enter**. Then keep finger on **Shift**.
 21. Replace the 150 Ω resistor for cell 2 with a 200 Ω precision resistor.
 22. Release **Shift** key. When display returns to tCC2, press **Next** once to display tCH2. Press **Enter**.
 23. Display will show 200.0 ohms. Press **Shift** and hold for 20 seconds, then press **Enter**.
- This completes the RTD Temperature Calibration.

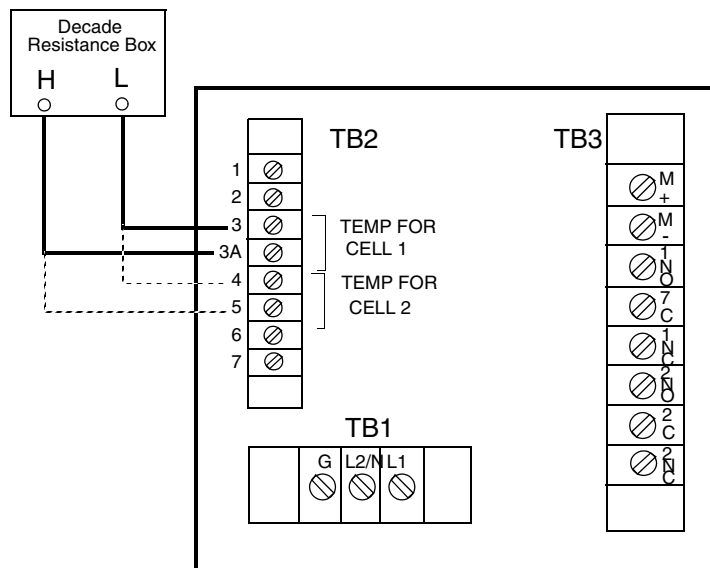

Figure 20. RTD Temperature Simulation (Plastic Enclosure Shown)

Changing the Analog Output

To change one or both of your analog outputs to a different output than the Analyzer was ordered with, jumpers must be moved and a recalibration performed.

To Reposition Jumpers

⚠ CAUTION

Use proper ESD precautions when opening this instrument for any servicing.

1. Remove power to the unit.
2. On Plastic enclosure, remove optional rear cover. Remove the four screws holding back panel in place.

On the metal enclosure, remove the four front corner screws holding the display panel in place. Remove rear cover. Disconnect the green earth (ground) cable; then feed wire from sensors and power connection through seals to allow free movement of circuit boards.

⚠ CAUTION

The four screws are self-tapping and have a limited grip. Do not repeatedly remove and tighten these screws.

3. Slide circuit assembly out to access the upper circuit board designated AS700EA. Plastic enclosure slides out from the rear of its housing. Metal enclosure slides out from the front of its housing.
4. Refer to Figure 21 to identify jumper locations.
5. Use Table 14 to locate appropriate jumper positions.

Table 14. Jumper Position for the Various Analog Outputs

Analog Output	J5	J6	J7	J10
4 - 20 mA	2 - 3	2 - 3	2 - 3	2 - 3
0 - 20 mA	2 - 3	2 - 3	2 - 3	2 - 3
0 - 10 V dc	1 - 2	1 - 2	1 - 2	1 - 2

6. Move each jumper to its appropriate position.
7. Replace board assembly inside unit.

⚠ CAUTION

On the plastic enclosure, a string must be rigged through the loop in the ribbon cable such that when the board assembly is slid into the housing, the string/ribbon cable may be pulled back simultaneously, thus preventing damage to the cable. See Figure 21.

8. Replace cover. On metal enclosures, use Loctite (Part No. S0106ML) on the threads of the front bezel screws, and Lubriplate (Part No. X0114AT) on the threads of the rear cover screws.
9. An analog output calibration will now be necessary. Refer to “Analog Output Calibration (LC01, HC01, LC02, HC02)” on page 55.
10. Make appropriate changes to the Analyzer identification label.

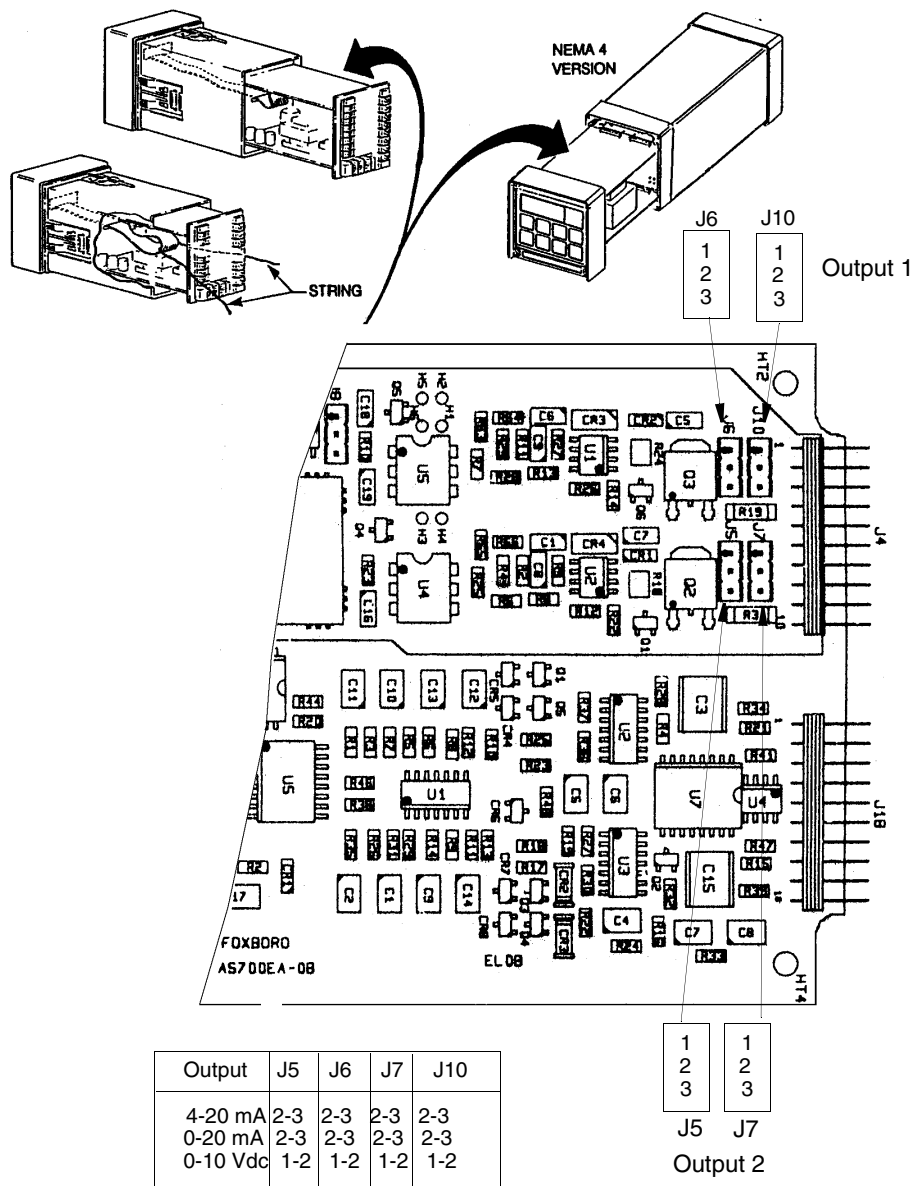

Figure 21. Jumpers for Changing Analog Output

Analog Output Calibration (LC01, HC01, LC02, HC02)

This procedure is used to calibrate the Analog output. As this has been done at the factory, recalibration should not be required unless the type of output has been changed. An ammeter or voltmeter is required.

1. Connect an ammeter/voltmeter to the analog output terminals. See Figure 19 and “Wiring of Plastic Enclosure” on page 16 or “Wiring of Metal Enclosure” on page 17.
2. Unlock the Analyzer using the security code.
3. Press **Shift** and while holding, press **Setup**. Release both keys.
4. Press **Next** several times until the code bL is displayed. Press **Enter**.
5. Use **Next** and Δ repeatedly until the personal security code is displayed (0800 from the factory). Press **Enter**.
6. When display returns to bL, press **Next** until LC01 is displayed. Press **Enter**.
7. Calculate the low % input required by using the following formula:

$$\text{Percent} = \frac{\text{Observed Reading} - \text{Desired Reading}}{\text{Analog High}} \times 100$$

Example:

$$\frac{(3.78 - 4.00\text{mA})}{20.00\text{mA}} \times 100 = -1.1\text{Percent}$$

8. Use **Next** and Δ repeatedly until the calculated value from Step 7 is displayed. Press **Enter**.

— NOTE

Iteration of the above procedure may be required. Repeat Steps 7 and 8 until Observed Value is equal to the Desired Value.

— NOTE

To make a minus sign appear on the display requires a digit other than zero to be present on the display. Example: To make the display read -1.1%, first display 01.1% and then change the first digit to a negative sign.

9. When the display returns to LC01, press **Next** once to display HC01. Press **Enter**.
10. Calculate the high % required using the following formula:

$$\text{Percent} = \frac{\text{Observed Reading}}{\text{Desired Reading}} \times 100$$

Example:

$$\frac{10.42\text{V}}{10.00} \times 100 = 104.2\text{ Percent}$$

11. Press **Next** and Δ repeatedly until the calculated value from Step 10 is displayed. Press **Enter**.

— NOTE

1. Repeat Steps 10 and 11 until Observed Value is equal to the Desired Value.
2. Procedure complete here for plastic enclosure.

12. For metal enclosure with a second output, move ammeter to second set of terminals. Repeat Steps 3-5, then press **Next** once until LC02 is displayed. Press **Enter**.
13. Calculate the low % input required by using the following formula:

$$\text{Percent} = \frac{\text{Observed Reading} - \text{Desired Reading}}{\text{Analog High}} \times 100$$

Example:

$$\frac{(3.78 - 4.00\text{mA})}{20.00\text{mA}} \times 100 = -1.1\text{Percent}$$

— NOTE

To make a minus sign appear on the display requires a digit other than zero to be present on the display. Example: To make the display read -1.1%, first display 01.1%, then change the first digit to a negative sign.

14. Press **Next** and Δ repeatedly until the calculated value from Step 13 is displayed. Press **Enter**.

— NOTE

Iteration of the above procedure may be required. Repeat Steps 13 and 14 until Observed Value is equal to Desired Value.

15. When the display returns to LC02, press **Next** once to display HC02. Press **Enter**.
16. Calculate the high % required using the following formula:

$$\text{Percent} = \frac{\text{Observed Reading}}{\text{Desired Reading}} \times 100$$

Example:

$$\frac{10.42\text{V}}{10.00\text{V}} \times 100 = 104.2 \text{ Percent}$$

17. Use **Next** and Δ until the calculated value from Step 16 is displayed. Press **Enter**.

— NOTE

Repeat Steps 16 and 17 until Observed Value is equal to the Desired Value.

18. Lock Analyzer using procedure in “Locking Analyzer Using Security Code” on page 26.

This completes the Analog Output Calibration Procedure.

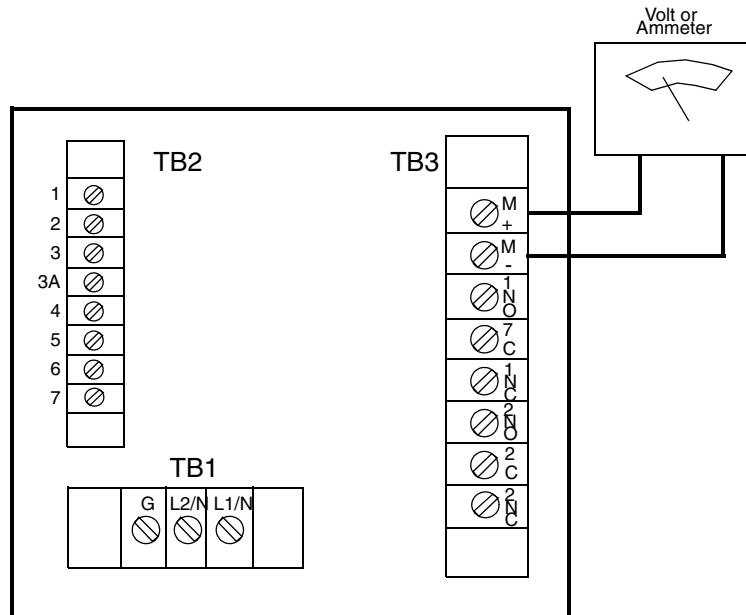

Figure 22. Output Terminals and Volt/Amm Meter (Plastic Enclosure Shown)

Changing the Security Code (LCC)

The following procedure is used to change the security code to another 4-digit code.

— **NOTE** —

If existing security code is forgotten, a new security code cannot be entered using this procedure. In such a case, contact Invensys Foxboro.

1. Leave power on.
2. Press **Lock**. Display will show either Loc or Uloc.
3. If uLoc is displayed, proceed to Step 4.
4. If Loc is displayed, unlock the Analyzer using the procedure explained in “Unlocking Analyzer Using Security Code” on page 26. Display will read uLoc.
5. Press **Shift** and while holding, press **Setup**. Release fingers from both keys.
6. Press **Next** several times until the code bL (Basic Setup Lock) is displayed. Press **Enter**.
7. Then use **Next** and Δ repeatedly until existing security code is displayed (0800 from factory).
8. Press **Enter**.
9. When display returns to bL, press **Next** several times until the code LCC (Lock Code Change) is displayed.
10. Press **Enter**, then press the **Next** and increment (Δ) keys repeatedly until new desired security code is displayed.
11. Press **Enter**. The new code will have to be used on all future entries.

12. Lock the Analyzer using the procedures explained in “Locking Analyzer Using Security Code” on page 26.

5. Calibration

The Calibration section is divided into two parts.

“Electronic Bench Calibration” on page 59 contains the procedure for calibrating the 873RS Analyzer with precision resistors and their theoretical values. In many cases this calibration produces sufficient accuracy for the user application.

“Calibrating the Analyzer to a Specific Sensor” on page 65 provides additional calibration procedures and standardization techniques. These additional procedures are recommended to obtain the best system accuracy. These procedures **MUST BE USED** when additional extension cables or junction boxes are used in installations.

—  **WARNING** —

On metal units, do not remove four front panel screws and remove electronics package for calibration. The screws will not function properly with repeated use.

Electronic Bench Calibration

— **NOTE** —

Holding the Shift key between entries will prevent the Analyzer from timing out and leaving the Setup entries.

This procedure is used to calibrate the 873 Analyzers with precision resistors and their theoretical values. After this procedure is completed, the Cal Lo, Cal Hi, and Phase keys **SHOULD NOT BE TOUCHED**.

— **NOTE** —

Invensys Foxboro calibrates and configures all 873 Analyzers before leaving the factory with resistors of 0.1% accuracy. Calibration of this unit with resistors of less accuracy will compromise the accuracy specifications of this unit. Calibration may be verified by installing resistors on the unit.

—  **CAUTION** —

Do not press **Enter** if you are checking the calibration. It should not be necessary to implement the Electronic Bench Calibration unless the FSC has been changed or entered, or the Cal Hi and/or Cal Lo has been changed or entered.

Required:

Precision resistors corresponding to the High Cal value, a 100 K Ω or 110 Ω resistor for temperature simulation, and a 0.001 μ F polycarbonate capacitor (Part No. H0176AA) are required for this procedure.

Calibration Kit (Part No. BS805YZ included with each 873RS) contains parts necessary for verifying calibration to the 20 M Ω •cm or 10 M Ω •cm ranges as well as the appropriate capacitor. The resistors included in this kit are only 1% resistors. Using these to calibrate this instrument

will reduce the accuracy specification on this instrument. A resistance decade box should not be used for the electronic bench calibration; the cable connection will add “quadrature” during the calibration. This will result in erroneous resistivity values.

Procedure:

Calibration of Cell 1 Channel:

1. Disconnect all sensor leads from terminal strip TB2.
2. Unlock Analyzer (see “Unlocking Analyzer Using Security Code” on page 26).
3. Check and adjust the Cell code of the unit. Refer to “CELL Display and Output Configuration (CELL)” on page 28. Set this code so the first digit is 1: “1XXX”.
4. Check and adjust the Cd code of the unit. Refer to “Compensation and Damping (Cd)” on page 31. Set this code to read “0000”. The unit should have no damping and should utilize absolute temperature compensation.
5. Reset the Full Scale value of the Analyzer. Refer to “Changing the Full Scale Range (FSC)” on page 46. Even if the existing Full Scale value is the desired value, it is important to reenter the same value. When the FSC value is entered, Error Code “ER4” should begin to flash on the display.

— NOTE —

1. If an Error Code of higher priority is present, it will preempt the ER4 message.
 2. Holding the **Shift** key between entries will prevent the Analyzer from timing out and leaving the Setup entries.
-

6. Reset CF1 to .1000 (the theoretical cell factor). Press **Enter**. See “Calibrating the Analyzer to a Specific Sensor” on page 65.
7. Reset tCF1 to 25.00 (the theoretical temperature transducer value). Press **Enter**. See “Calibrating the Analyzer to a Specific Sensor” on page 65.
8. Checking the Temperature Circuit Calibration
 - a. Determine which type temperature compensation your Analyzer has by checking the CONFIGURATION CD entry on the model identification label affixed to the Analyzer (see Figure 4).

— NOTE —

The 871CC Sensor types A through F use a 100 k Ω thermistor for automatic temperature compensation. The 871CC Sensors K through M use a 100 Ω RTD for automatic temperature compensation and are recommended for all measurements at elevated temperatures.

Connect a 110 Ω or a 100 k Ω resistor as applicable across terminals 3 and 3A on terminal TB2. Refer to Figure 23.

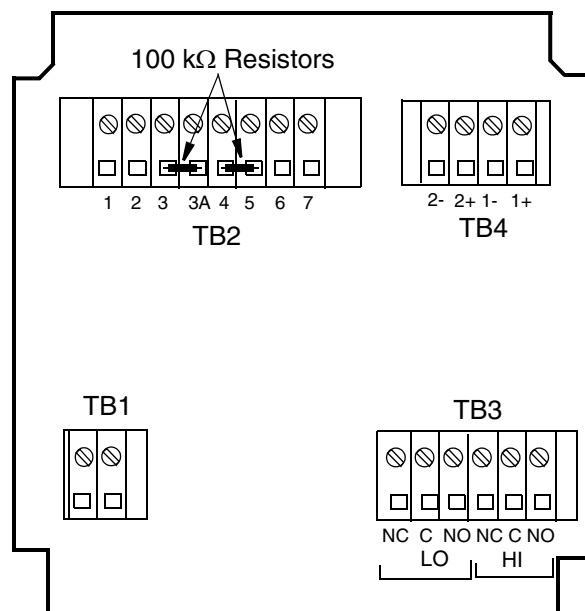

Figure 23. Temperature Simulation (NEMA 4X Enclosure Shown)

- b. Press **Temp**. The unit should be in the Automatic Temperature mode; no decimal should be visible after the “C” or “F” legend. If there is a decimal after the “C” or “F” legend, it should be removed. Press the increment key (Δ) once after pressing **Temp**; then press **Enter**. This removes the decimal.
 - c. Press **Temp**. The display should read approximately “25.C” or “77.F”. If the display does not read these values, verify that the correct resistor is being used, and ensure that it is installed correctly. If these measures do not improve the value, see “Changing the Temperature Circuitry” on page 47 for recalibrating procedures.
9. Zero and Span Calibration
- a. Produce a short across terminals 1 and 2 on terminal TB2. This may be accomplished by attaching a short wire between contacts 1 and 2.
 - b. Wait at least 15 seconds for the electronics to stabilize.
 - c. Press **Shift** and while holding, press **Cal Lo**. Use **Next** and Δ repeatedly until the display reads 0.00. Press **Enter**. Remove the shorting wire.
 - d. Calculate the Resistance Input required for Calibrate High Value. The Cal Hi value should fall within the range of the FSC that has been chosen.

Resistance Input = Cell Factor x Cal Hi Value

(in $M \bullet \Omega$) (0.100 cm^{-1}) ($M \Omega \bullet \text{cm}$)

Example:

For a resistivity display of 20.00 M Ω •cm,
 Resistance Input = (0.1000)(20) = 2.000 M• Ω
 Other sample resistance inputs:
 For a display of 18.00 M Ω •cm,
 Resistance Input = 1.800 M Ω
 For a display of 10.00 M Ω •cm,
 Resistance Input = 1.000 M Ω
 For a display of 2.000 M Ω •cm,
 Resistance Input = .2000 M• Ω

- e. Connect resistor corresponding to calculated Cal Hi Value between terminals 1 and 2 of TB2 (see Figure 24).
- f. Wait at least 15 seconds for the electronics to stabilize.
- g. Press **Shift** and while holding, press **Cal Hi**. Press **Next** and Δ repeatedly until the display reads desired Cal Hi value. Press **Enter**. Leave the resistor across the terminals. The Er 4 flag will continue to flash.

10. The Phase Calibration

This part of the Bench Calibration procedure adjusts the Analyzer for changes in capacitance that may be introduced by the cable or sensor.

- a. Connect a .001 μ F polycarbonate capacitor across terminals 1 and 2 of TB2 leaving the resistor connected from the previous step (in parallel with the resistor). Refer to Figure 24.
- b. Wait at least 15 seconds for the electronics to stabilize.
- c. Press **Shift** and while holding, press **Phase**. Display will read Cal Hi setting. Press **Enter**. The ER4 code should stop flashing.
- d. Remove capacitor from terminals 1 and 2 of TB2. Leave resistor connected. Wait at least 15 seconds.
- e. Press **Shift** and while holding, press **Cal Hi**. Use **Next** and Δ repeatedly until the display reads desired Cal Hi value. Press **Enter**.

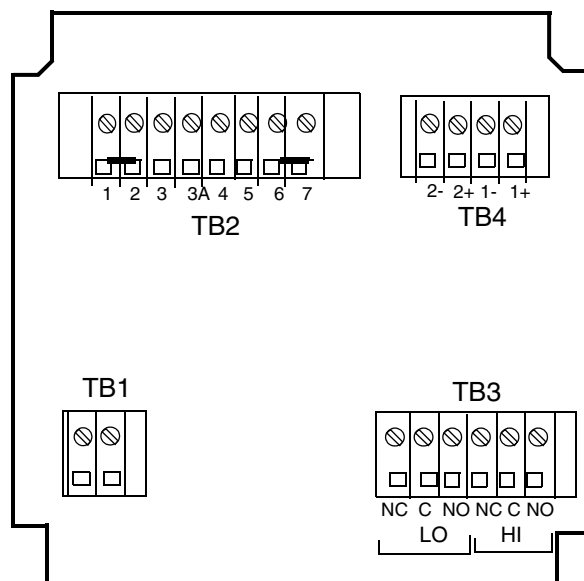

Figure 24. Bench Calibration (NEMA 4X Enclosure Shown)

Calibration of Cell 2 Channel

11. Check and adjust the Cell code of the unit so that Cell 2 is displayed. Refer to “CELL Display and Output Configuration (CELL)” on page 28. Set this code so the first digit is 2: “2XXX”.
12. Reset CF2 to .1000 (the theoretical cell factor). Press **Enter**. See “Calibrating the Analyzer to a Specific Sensor” on page 65.
13. Reset tCF2 to 25.00 (the theoretical temperature transducer value). Press **Enter**. See “Calibrating the Analyzer to a Specific Sensor” on page 65.
14. The Temperature Circuit calibration must first be checked.
 - a. Determine which type temperature compensation your Analyzer is set up for by checking the CONFIGURATION CD entry on the model identification label affixed to the Analyzer. See Figure 4.

— NOTE —

The 871CC Sensor types A through F use a 100 k Ω thermistor for automatic temperature compensation. The 871CC Sensors K through M use a 100 Ω RTD for automatic temperature compensation and are recommended for all measurements at elevated temperatures.

Connect a 110 Ω or 100 k Ω resistor as applicable across terminals 4 and 5 on terminal strip TB2. Refer to Figure 23.

- b. Press **Temp**. The unit should be in the Automatic Temperature mode; no decimal should be visible after the “C” or “F” legend. If there is a decimal after the “C” or “F” legend, it should be removed. Press Δ once after pressing **Temp**; then press **Enter**. This removes the decimal.

- c. Press **Temp**. The display should read approximately “25.C” or “77.F”. If the display does not read these values, verify that the correct resistor is being used and ensure that it is installed correctly. If the response is not improved by these measures, go to “Changing the Temperature Circuitry” on page 47 for recalibration.

15. Zero and Span Calibration

- a. Produce a short across terminals 6 and 7 of terminal strip TB2.
- b. Wait at least 15 seconds for the electronics to stabilize.
- c. Press **Shift** and while holding, press **Cal Lo**. Use **Next** and Δ repeatedly until the display reads 0.00. Press **Enter**. Remove shorting wire.
- d. Calculate the Resistance Input required for Calibrate High Value. The Cal Hi value should fall within the range of the FSC that has been chosen.

$$\begin{aligned} \text{Resistance Input} &= \text{Cell Factor} \times \text{Cal Hi Value} \\ (\text{in } M\Omega) &\quad (0.1000 \text{ cm}^{-1}) (M\Omega \bullet \text{cm}) \end{aligned}$$

Example:

For a resistivity display of 20.00 $M\Omega \bullet \text{cm}$,

$$\begin{aligned} \text{Resistance Input} &= (0.1000)(20) = 2.000 \text{ } M\Omega \\ (\text{Calibration Kit contains } 2.00 \text{ } M\Omega \text{ resistor}) \end{aligned}$$

Other sample resistance inputs:

For a display of 18.00 $M\Omega \bullet \text{cm}$,

$$\text{Resistance Input} = 1.800 \text{ } M\Omega$$

For a display of 10.00 $M\Omega \bullet \text{cm}$,

$$\text{Resistance Input} = 1.000 \text{ } M\Omega$$

For a display of 2.000 $M\Omega \bullet \text{cm}$,

$$\text{Resistance Input} = .2000 \text{ } M\Omega$$

- e. Connect resistor corresponding to calculated value between terminals 6 and 7 of TB2. See Figure 24.
- f. Wait at least 15 seconds for the electronics to stabilize.
- g. Press **Shift** and while holding, press **Cal Hi**. Use **Next** and Δ repeatedly until the display reads desired Cal Hi value. Press **Enter**. Leave the resistor across the terminals.

16. The Phase Calibration

This part of the Bench Calibration procedure adjusts the Analyzer for changes in capacitance that may be introduced by the cable or sensor.

- a. Connect a .001 μF polycarbonate capacitor across terminals 6 and 7 of TB2 leaving the resistor connected from the previous step (in parallel with the resistor). Refer to Figure 24.
- b. Wait at least 15 seconds for the electronics to stabilize.

- c. Press **Shift** and while holding, press **Phase**. Display will read Cal Hi setting. Press **Enter**. The ER4 code should stop flashing.
 - d. Remove capacitor from terminals 6 and 7 of TB2. Leave resistor connected. Wait at least 15 seconds.
 - e. Press **Shift** and while holding, press **Cal Hi**. Press **Next** and Δ repeatedly until the display reads desired Cal Hi value. Press **Enter**.
17. Disconnect resistors from terminal strip TB2.
 18. Reconnect all sensor leads to terminal strip TB2.
 19. Press **Temp**. The unit should be in the automatic temperature compensation mode (no decimal after the legend). If it is not, press Δ either once (Fahrenheit) or three times (Centigrade) to remove the decimal point after the F or C legend. Press **Enter**.
 20. Check and adjust the Cd code of the unit to the desired values. For temperature compensation of ultrapure water, the fourth digit of this code must be a 1;X001. Refer to “Compensation and Damping (Cd)” on page 31.

Check and adjust the CELL code of the unit to the desired values (“CELL Display and Output Configuration (CELL)” on page 28).
 21. Lock Analyzer (see “Locking Analyzer Using Security Code” on page 26).

This completes the Electronic Bench Calibration.

Calibrating the Analyzer to a Specific Sensor

Temperature Cell Factor (tCF1 and tCF2) and Cell Factor (CF1 and CF2) Adjustments

Invensys Foxboro resistivity sensors are manufactured under strict guidelines for quality and uniformity. Even with the stringent specifications of our assembly procedures, small offsets from theoretical values are possible. Under many circumstances, the theoretical bench calibration and a sensor can still provide sufficient information to the user. In these cases, the sensor should be connected to the Analyzer and used without further calibration.

— **NOTE** —

For the best possible system accuracy of an 873RS and 871CC sensor, additional calibrations are required to standardize these small offsets.

An accurate temperature signal is required for proper pure water temperature compensation, especially when measuring over a large temperature gradient. The temperature cell factors (tCF1 and tCF2) are used to offset a small deviation from ideal for the two sensors. If patch cables are used, a new tCF must be determined and input. At 25.0°C, a 0.1°C error in temperature can result in a resistivity error of 1.1%.

— NOTE —

The 871CC Sensor type A through F use a 100 k Ω thermistor for automatic temperature compensation. The 871CC Sensors K through M use a 100 Ω RTD for automatic temperature compensation and are recommended for all measurements at elevated temperature.

Additionally, individual sensor cell factors may differ slightly from $.1000 \text{ cm}^{-1}$ (their nominal constant). The cell factors (CF1 and CF2) are used to offset these small deviations from ideality for the two sensors.

871CC Sensors are stamped with a 4-digit number (such as .1001) which is the cell factor (CF) of that particular cell when tested in our factory. These cells are also stamped with a temperature value (tCF) (such as 24.97°C) which is the temperature where that particular transducer read its theoretical resistance value. See Figure 25. When the sensor is connected directly to the Analyzer, these cell factors may be input directly into the 873RS to correct for these offsets. Alternately, the procedures that follow may be used to determine these offset values, and must be used when additional cable lengths or junction boxes are used with the sensors.

Determining tCF

1. Place 871CC sensor and an accurate Centigrade thermometer (with $.10^\circ\text{C}$ resolution) into a container of water. Allow the system to reach thermal equilibrium.
2. Press **Temp**. Put the Analyzer into Automatic Temperature Compensation, no decimal after the C. If there is a decimal after the C, it may be removed. Press Δ once after pressing **Temp**; then press **Enter**.

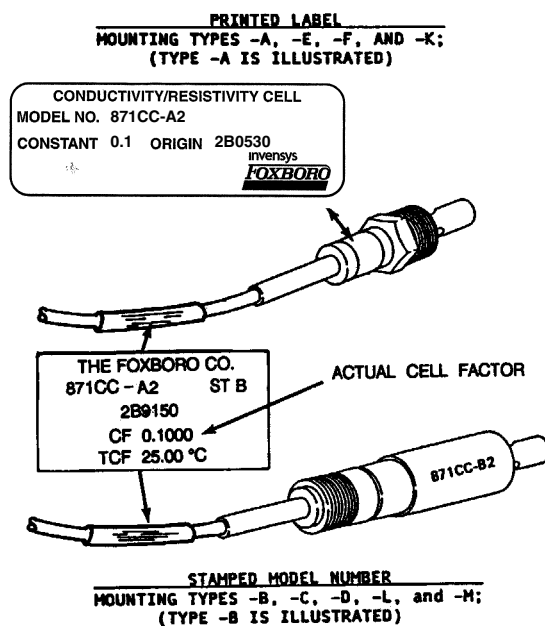

Figure 25. Sensor Identification

3. Read the temperature displayed on the 873 to the hundredths place. When **Temp** is pressed, the current temperature value with tenths place will alternate with the **C** legend. The value read by the 873 must now be viewed to the hundredths place. Press **Temp** followed by **Next** five times. Only three numbers may be viewed on the display, and the first digit will not be visible (e.g., 25.20 will be displayed as 5.20).
4. Determine the difference in values between the two temperature devices; e.g., the thermometer reads 24.70°C, and the 873 says (2)5.20 C; the 873 is reading higher by .50°C.
5. Subtract this value from 25.00 (e.g., 25.00 – .50 = 24.50). This is your new TCF value.

— **NOTE** —

If the 873 value is less than the thermometer, the difference should be added to 25.00.

Entering a tCF Value

— **NOTE** —

1. Before this procedure is performed, verify that the 873RS Analyzer has been electronically bench-calibrated. Electronic bench calibration is performed at the factory on all new Analyzers.
 2. After performing the procedure given below, the use of keys Cal Hi and Cal Lo is not feasible. The procedure given in the “Electronic Bench Calibration” on page 59 must precede, not follow, the procedure below.
-
1. Unlock Analyzer (see “Unlocking Analyzer Using “Unlocking Analyzer Using Security Code” on page 26).
 2. Press **Shift** and while holding, press **Setup**. Release fingers from both keys.
 3. Press **Next** several times until the code bL (Basic Setup Lock) is displayed.
 4. Press **Enter** and then use **Next** and Δ repeatedly until personal security code is displayed (0800 from factory).
 5. Press **Enter**.
 6. When display returns to bL, press **Next** several times until the entry tCF1 or tCF2 (depending upon the cell value you are entering) is displayed.
 7. Press **Enter** and then use **Next** and Δ repeatedly until desired value (matching the data on the cell) is displayed.
 8. Press **Enter**.
 9. Recheck any differences that exist between a thermometer and temperature displayed on the 873.
 10. Lock Analyzer using procedure in “Locking Analyzer Using Security Code” on page 26.

Determining (or Verifying) a CF

— NOTE

1. The following procedure is used to determine or verify a CF value. To avoid contaminating the cell, sensors should be handled by the cable end only.
 2. Sensors should not be placed into solutions containing oils or chemicals that could coat the cells and change the cell factor.
 3. Resistivity standard solutions are not commercially available. A known solution resistivity or a “Standard” cell, an 871CC sensor whose cell factor (CF) is known, is required with this procedure.
-

1. Install sensor into a flowing clean water loop whose resistivity is known or along with an 871CC sensor whose cell factor is known.
2. Allow sensor to reach steady state equilibrium. Allow one hour or more for this to occur; the values displayed on the Analyzer should stop changing. The cell actually will be “cleaning” itself off during this time.
3. If two sensors are being compared, verify that their temperatures are in agreement.
4. Adjust the Cd code of the 873 to 0000 to read absolute conductivity. Refer to “Compensation and Damping (Cd)” on page 31.
5. Adjust and enter the CF code for the sensor whose value is known. See “Entering a CF Value” on page 69.
6. Adjust and enter CF code .1000 for sensor whose CF is to be determined.
7. Read the apparent resistivity displayed for the sensor whose CF is being determined. Read the resistivity displayed for the solution that is known.
8. Using either equation below, calculate the cell factor for the sensor being tested:

$$\frac{\text{Resistivity from Cell CF unknown} \times .100}{\text{Resistivity from Cell CF known}} = \text{CELL FACTOR}$$

or

$$\frac{\text{Resistivity from Cell CF unknown} \times .100}{\text{Known Solution Resistivity}} = \text{CELL FACTOR}$$

Example 1:

The solution resistivity is known to be 10.12 MΩ•cm. The sensor being tested reads 10.15 MΩ•cm.

$$\text{CF} = \frac{10.15 \times .1}{10.12} = .1003$$

Example 2:

The solution resistivity is found to be 18.05 MΩ•cm. The sensor whose CF is being determined reads 17.89 MΩ•cm.

$$CF = \frac{17.89 \times .1}{18.05} = .0991$$

9. Enter the new CF value (“Entering a CF Value” on page 69).
10. Adjust the Cd code of the 873 to X001 if temperature compensation for pure water is desired. Refer to “Compensation and Damping (Cd)” on page 31. The unit may have damping input by this code also.

Entering a CF Value

— NOTE —

1. This procedure should be implemented after the 873RS Analyzer has been electronically bench calibrated. The theoretical value of .1000 cm⁻¹ is input to the Analyzer at the factory on all new Analyzers.
 2. After performing the procedure given below, the use of keys Cal Hi and Cal Lo is not feasible. The procedure given in “Electronic Bench Calibration” on page 59 must precede, not follow, the procedure below.
-
1. Unlock Analyzer (see “Unlocking Analyzer Using Security Code” on page 26).
 2. Press **Shift** and while holding, press **Setup**. Release fingers from both keys.
 3. Press **Next** several times until the code bL (Basic Setup Lock) is displayed.
 4. Press **Enter** and then press **Next** and Δ repeatedly until personal security code is displayed (0800 from factory).
 5. Press **Enter**.
 6. When display returns to bL, press **Next** several times until the entry CF1 or CF2 (depending on the cell you wish to "fine tune") is displayed.
 7. Press **Enter**, then press **Next** and Δ repeatedly until desired value (matching the data on the cell) is displayed.
 8. Press **Enter**.
 9. Recheck any differences that exist between sensors on the 873 using the technique described previously.
 10. Lock Analyzer (see “Locking Analyzer Using Security Code” on page 26).

6. Diagnostics

Troubleshooting

Table 15. Troubleshooting Symptoms

Symptom	Approach
Noisy Signal	May be flow related. 1. Check Analyzer noise by simulating sensor signal with a resistor. 2. Increase damping. 3. Reorient sensor.
Resistivity Increases	Gas bubbles may be trapped.
Resistivity Reads Incorrectly Temperature Reads Incorrectly	1. Check to see if correct TCF is being used. Extension cables and junction box use will require a new TCF be determined. 2. Verify 873 is set up for proper temperature transducer. See “Electronic Bench Calibration” on page 59, Items 8 and 14.
Accuracy	1. Accuracy of the sensor may be affected by deposits from the process liquid. Consult sensor MI for cleaning recommendations.

Error Codes

When the Analyzer is operating normally, the measurement value is displayed constantly. If error or alarm conditions exist, the display alternates between the measurement value and the error/alarm message at a one second rate. The alternate (error/alarm) messages are shown in Table 16.

Table 16. Error/Alarm Messages

Alternate Display	Condition	Priority	Action Required to Clear Message
Er 1	Instrument Fault, RAM/ROM, software watchdog timer	1 (Highest)	1. Reenter security code in LCC code twice. See “Changing the Security Code (LCC)” on page 57. 2. Power down unit.
Er 2	User-defined temperature range error or temperature measurement error Analyzer set up for wrong temperature transducer	3	1. Change user-defined temperature limits. UtL or LtL. 2. Replace sensor. 3. Place temperature in manual mode (e.g., 25.C.) 4. See “Changing the Temperature Circuitry” on page 47.
Er 3	User-defined measurement range error	4	1. Change user-defined measurement limits, UL or LL. 2. Replace sensor.
Er 4	Measurement calibration incorrect	2	Recalibrate Analyzer using Bench Calibration procedure.
A Hi	Measurement in H alarm	6	H Alm state, timers on, or in deadband.
A HH	Measurement in HiHi alarm	5	Both Alarms configured as High Alarms.
A LO	Measurement in L alarm	8	L Alm state, timers on, or in deadband.
A LL	Measurement in LoLo alarm	7	Measurements must remain within HO1 and LO1 (HO2 or LO2) limits configured.
****	Measurement over or under range of analog output limits	9	
Err	Incorrect code or parameter attempted	2	Check code and reenter.

— NOTE —

If two or more errors exist simultaneously, the Analyzer will flash only the error with the highest priority. If the highest priority error is cleared and a lower priority error still remains, the Analyzer will then flash the highest priority error of the remaining errors.

Detachable Configuration Field Sheet

Configuration Setup Entries

Displayed Symbol	Parameters and Values Accessed	User Settings	Displayed Symbol	Parameters and Values Accessed	User Settings
CELL	Configuration of Display and Analog Outputs		LAIt	Low Alarm Trigger Time	
Hold	Hold and sets the Analog output value in Hold		LAft	Low Alarm Feed Time	
Cd	Temperature Compensation and Damping Damping Factor Temperature Compensation		LAdL	Low Alarm Delay Time	
HAC	H Alarm Configuration Measurement Selection Low/High/Instrument plus Passive/Active State % Hysteresis		UL	User-Defined Upper Measurement Limit - Both Cells	
HAtt	High Alarm Trigger Time		LL	User-Defined Lower Measurement Limit - Both Cells	
HAft	High Alarm Feed Time		UtL	User-Defined Upper Temperature Limit - Both Cells	
HAdL	High Alarm Delay Time		LtL	User-Defined Lower Temperature Limit - Both Cells	
LAC	L Alarm Configuration Measurement Selection Low/High/Instrument plus Passive/Active State % Hysteresis		HO1	100% Analog Output - Channel 1	
HO2	100% Analog Output - Channel 2		LO1	0% Analog Output - Channel 1	
LO2	0% Analog Output - Channel 2				

Basic Setup Entry Selection

Symbol	Parameter and Value Accessed	User Settings
bL	Basic Setup Lock Control	
FSC	Full Scale Value	
CF 1	Cell Factor - Cell 1	
tCF 1	Temperature Cell Factor - Cell 1	
tEC 1	Thermistor Temperature Electronics Calibration Cell 1	
tCL 1	RTD Low Temperature Electronics Calibration Cell 1	
tCC 1	RTD Mid Temperature Electronics Calibration Cell 1	
tCH 1	RTD High Temperature Electronics Calibration Cell 1	
LCC	Lock Code Change	
CF 2	Cell Factor - Cell 2	
tCF 2	Temperature Cell Factor - Cell 2	
tEC 2	temperature Channel Electronics Calibration Cell 2	
tCL 2	RTD Low Temperature Electronics Calibration Cell 2	
tCC 2	RTD Mid Temperature Electronics Calibration Cell 2	
tCH 2	RTD High Temperature Electronics Calibration Cell 2	
LCCO1	Analog Out 1 Electronics Lower Calibration	
HCO1	Analog Out 1 Electronics Upper Calibration	
LCO2	Analog Out 2 Electronics Lower Calibration	
HCO2	Analog Out 2 Electronics Upper Calibration	
Sft	Software Version Number	
SOH	Sales Order High	
SOL	Sales Order Low	

Hold Code—Hold Analog Output Values

Digit 1	Digits 2, 3, and 4
0 = No Hold	
Hold ON, Analog Output on Hold	000 to 100% of Analog Output Range
1 - Alarms held in present state	
2 - Alarms held in off state	
3 - Alarms held in on state	

CELL Code—Display and Output Configuration

Digit 1	Digit 2	Digit 3	Digit 4
Measurement And Display	Not Used	Output 1	Output 2
1 - Measures and displays Cell 1 only 2 - Measures and displays Cell 2 only 3 - Measures Cell 1 and Cell 2 Displays Cell 1 4 - Measures Cell 1 and Cell 2 Displays Cell 2 7 - Ratio 8 - % Rejection	Digit 2 is not used and should be set at 0.	1 - Resist. Cell 1 2 - Resist. Cell 2 3 - Temp Cell 1 4 - Temp Cell 2 5 - Log (resist. Cel1) 6 - Log (resis. Cel2) 7 - Ratio 8 - % Rejection	1 - Resist. Cell 1 2 - Resist. Cell 2 3 - Temp Cell 1 4 - Temp Cell 2 5 - Log (resist. Cel1) 6 - Log (resis. Cel2) 7 - Ratio 8 - % Rejection

Cd Code—Compensation and Damping

Digit 1	Digit 2	Digit 3	Digit 4
Damping	Not Used	Not Used	Temperature Compensation
0 = none 1 = 10 second 2 = 20 second 3 = 40 second	ENTER 0	ENTER 0	0 = Absolute (no compensation) 1 = Ultrapure water temperature correction applied M W Pcm resistivity is referenced to 25° C

UL = The Upper Limit is 999.9 MΩ•cm.

LL = The Lower Limit is -.999 MΩ•cm.

UtL = The Upper Limit is 200°C.

LtL = The Lower Limit is -20°C (-5°F).

H01 = May be set to any value between -0.99 and 99.99.

L01 = May be set to any value between -0.99 and 99.99.

H02 = May be set to any value between -0.99 and 99.99.

L02 = May be set to any value between -0.99 and 99.99

HAC and LAC Codes—Alarm Configuration

Digit 1	Digit 2	Digits 3 & 4
Alarm Selection	Configuration	Hysteresis
1 - Meas Cell 1 2 - Meas Cell 2 3 - Temp Cell 1 4 - Temp Cell 2 7 - % Ratio 8 - % Rejection	1 - Low/Passive 2 - Low/Active 3 - High/Passive 4 - High/Active 5 - Instrument/Passive 6 - Instrument/Active 7 - Hold/Passive 8 - Hold/Active	00 to 99% of Full Scale

HAFt, HADL, LAfT, and LAdL Time Codes

Digits 1 and 2	Digit 3	Digit 4
00 to 99 minutes	0 to 9 tenths of minutes	0 to 9 hundredths of minutes

Troubleshooting Symptoms

Symptom	Approach
Noisy Signal	May be flow related 1. Check Analyzer noise by simulating sensor signal with a resistor. 2. Increase damping. 3. Reorient sensor.
Resistivity Increases	Gas bubbles may be trapped.
Resistivity Reads Incorrectly Temperature Reads Incorrectly	1. Check to see if correct TCF is being used. Extension cables and junction box use will require a new TCF be determined. 2. Verify 873 is set up for proper temperature transducer. See Section 5.1, Items 8 and 14.
Accuracy	Accuracy of the sensor may be affected by deposits from the process liquid. Consult sensor MI for cleaning recommendations.

Error/Alarm Messages

Alternate Display	Condition	Priority	Action Required to Clear Message
Er 1	Instrument Fault, RAM/ROM, software watchdog timer	1 (Highest)	1. Reenter security code in LCC code twice. See "Changing the Security Code (LCC)" on page 57. 2. Power down unit.
Er 2	User-defined temperature range error or temperature measurement error Analyzer set up for wrong temperature transducer.	3	1. Change user-defined temperature limits. UtL or LtL. 2. Replace sensor. 3. Place temperature in manual mode (e.g., 25.C.) 4. See "Changing the Temperature Circuitry" on page 47.
Er 3	User-defined measurement range error	4	1. Change user-defined measurement limits, UL or LL. 2. Replace sensor.
Er 4	Measurement calibration incorrect	2	Recalibrate Analyzer using Bench Calibration procedure.
A Hi	Measurement in Hi alarm	6	H Alm state, timers on, or in deadband.
A HH	Measurement in HiHi alarm	5	Both Alarms configured as High Alarms.
A LO	Measurement in Lo alarm	8	L Alm state, timers on, or in deadband.
A LL	Measurement in LoLo alarm	7	Measurements must remain within HO1 and LO1 (HO2 or LO2) limits configured.
****	Measurement over or under range of analog output limits	9	H Alm state, timers on, or in deadband.
Err	Incorrect code or parameter attempted	2	Check code and reenter.

NOTE: If two or more errors exist simultaneously, the Analyzer will flash only the error with the highest priority. If the highest priority error is cleared and a lower priority error still remains, the Analyzer **will then flash the highest priority error of the remaining errors.**

For Warranty Information 1-866-746-6477
 For Electrochemistry Analyzer Repair/Troubleshooting Information 508-549-2168
 For Electrochemistry Technical Assistance and Application Support 508-549-4730
 Or by FAX 508-549-4734

7. User Notes

Single Sensor Use

This section allows fault-free setup of the 873RS for single sensor use. Because two sensor inputs are available on the 873 Analyzer, proper configuration is required to prevent errors from flagging. After wiring up the sensor, follow the steps below to determine the 5 pertinent configuration code assignments. Error codes will occur if the unit is configured improperly.

For Cell 1 Configuration

1. Wire Sensor to TB2.
Cell 1 terminals 1, 2, 3, 3A
2. Choose Cell Code.

Digit			
1	2	3	4
1	0 Not Used	1 or 3 or 5	1 or 3 or 5

3. Will you be using Analog output(s)?

If Yes, set to desired values.

See Section: “Output #1's 100% Analog Value (HO1)” on page 43 and “Output #1's 0% Analog Value (LO1)” on page 43.

If No, set to:

HO1 = 99.99 and LO 1 = -.99

4. Will you be using Alarms?

LAC			
Digit			
1	2	3	4
1 or 3			

HAC			
Digit			
1	2	3	4
1 or 3			

If Yes, set digits 2, 3, and 4 as desired.

If No, set LAC = 1100

set HAC = 1300

set L ALM = - .99

set H ALM= 99.99

For Cell 2 Configuration

1. Wire Sensor to TB2.

Cell 2 terminals 4, 5, 6, 7

2. Choose Cell Code.

Digit			
1	2	3	4
2	0 Not Used	2 or 4 or 6	2 or 4 or 6

If Yes, set to desired values. See Section: “Output #2's 100% Analog Value (H02)” on page 43 and “Output #2's 0% Analog Value (L02)” on page 44.

If No, set to:

HO2 = 99.99 and LO2 = -.99

3. Will you be using Alarms?

LAC			
Digit			
1	2	3	4
2 or 4	X	X	X
	X	X	X

HAC			
Digit			
1	2	3	4
2 or 4	X	S	X
	X	X	X

If Yes, set digits 2, 3, and 4 as desired.

If No, set LAC = 2100

set HAC = 2300

set L ALM = - .99

set H ALM = 99.99

Dual Sensor Use

Ratio:

For Ratio measurements, the sensor designated Cell 1 must be located physically on the untreated water source. Cell 2 is placed after the “clean up” operation.

Cell Code			
Digit			
1	2	3	4
7	0 Not Used	X	X

Where XX means any values.

Set digits 3 and 4 as desired. If the Analog outputs will be used, set H01, L01 and H02, L02 to the proper values. If an output will not be used (or NEMA 1 version), set to:

H01 and H02 = 99.99; L01 and L02 = -.99.

Percent Rejection:

For Percent Rejection measurements, the sensor designated Cell 1 must be located physically on the untreated water source. Cell 2 is placed after the “clean up” operation.

Cell Code			
Digit			
1	2	3	4
8	0	X	X

Where XX means any values.

Set digits 3 and 4 as desired. If the Analog outputs will be used, set H01, L01 and H02, L02 to the proper values. If an output will not be used (or NEMA 1 version), set to:

H01 and H02 = 99.99; L01 and L02 = -.99.

Redundant Sensor Operation

In extremely critical processes where an error in measurement could cause serious effects, two sensors can be used as a check of measurement. Cell 1 will be designated the primary cell from which measurement is taken. The cell code should be set.

Cell Code			
Digit			
1	2	3	4
3	0 Not Used	X	X

Where XX means any values.

Set the analog outputs as desired (digits 3 and 4 of cell code) to functions of Cell 1's operation. H01 and L01, H02 and L02 should be set appropriately.

Configure the alarms, HAC and LAC to Ratio measurement.

LAC			
Digit			
1	2	3	4
7	X	X	X

HAC			
Digit			
1	2	3	4
7	X	X	X

Determine acceptable variances between the two sensors at the control before alarming. Calculate the ratio relationship:

$$\frac{\text{Cell 1}}{\text{Cell 2}} \times 100$$

Set L ALM and H ALM and wire Alarm terminals to appropriate Alarm device.

Backup Sensor Operation

In certain applications, a second or backup sensor is installed but is not configured. In cases where the primary sensor indication is suspect, the second already installed sensor is simply configured into duty.

For Cell 1 Configuration

1. Wire Sensor to TB2.
Cell 1 terminals 1, 2, 3, 3A
2. Choose Cell Code.

Digit			
1	2	3	4
3	0 Not Used	1 or 3 or 5	1 or 3 or 5

3. Will you be using Analog output(s)?

If Yes, set to desired values.

See Section: “Output #1's 100% Analog Value (HO1)” on page 43 and “Output #1's 0% Analog Value (LO1)” on page 43.

If No, set to:

HO1 = 99.99 and LO 1 = -.99

4. Will you be using Alarms?

LAC			
Digit			
1	2	3	4
1 or 3			

HAC			
Digit			
1	2	3	4
1 or 3			

If Yes, set digits 2, 3, and 4 as desired.

If No, set LAC = 1100

set HAC = 1300

set L ALM = - .99

set H ALM= 99.99

For Cell 2 Configuration

1. Wire Sensor to TB2.

Cell 2 terminals 4, 5, 6, 7

2. Choose Cell Code.

Digit			
1	2	3	4
4	0 Not Used	2 or 4 or 6	2 or 4 or 6

If Yes, set to desired values.

See “Output #2’s 100% Analog Value (H02)” on page 43 and “Output #2’s 0% Analog Value (L02)” on page 44.

If No, set to:

HO2 = 99.99 and LO2 = -.99

3. Will you be using Alarms?

LAC			
Digit			
1	2	3	4
2	X	X	X
or 4	X	X	X

HAC			
Digit			
1	2	3	4
2	X	S	X
or 4	X	X	X

If Yes, set digits 2, 3, and 4 as desired.

If No, set LAC = 2100

set HAC = 2300

set L ALM = - .99

set H ALM= 99.99

8. Alarm Contact Maintenance

The alarm relay contacts are selected to switch loads equal to or greater than 20 watts. The minimum contact current is 1 ampere. The silver alloy contacts rely on the very slight arc generated during switching to eliminate oxide layers that form on the contacts. When the contacts are used at low (signal) levels, contact function may become unreliable over time due to the formation of an oxide layer on the contacts.

When contacts must be used at low levels, attention must be paid to contact condition. The maximum contact resistance for new relays is 100 milliohms. Values above this level or unstable values indicate deterioration of the contact surface as noted above and may result in unreliable alarm function.

The contact surfaces can be restored as follows:

1. Disconnect the alarm wiring from the analyzer.
2. Connect a load of 20 W or more as shown in Figure 26 so that both NO and NC contacts are exercised.
3. Use the analyzer to switch the alarm relay several times.
4. Disconnect the load installed in Step 2 and reconnect the wiring removed in Step 1.
5. Check to ensure that the alarms are functioning properly.

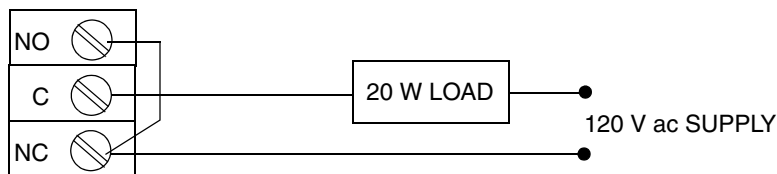

Figure 26. Alarm Contact Reconditioning Circuit

9. Warranty

Thank you for buying an Invensys Foxboro 873RS electrochemical analyzer. We also supply pH/ORP, contacting conductivity, and electrodeless conductivity analyzers and equipment. Contact us for your analysis needs.

For sales information or to place an order, contact your local Invensys Foxboro distributor or local Invensys Foxboro sales office.

For Warranty Information 1-866-746-6477
For Electrochemistry Analyzer Repair/Troubleshooting Information 508-549-2168
For Electrochemistry Technical Assistance and Application Support..... 508-549-4730
Or by FAX 508-549-4734

WARRANTY

Invensys Foxboro expressly warrants the products manufactured by it as meeting the applicable Invensys Foxboro product specifications. INVENSYS FOXBORO MAKES NO OTHER WARRANTIES EITHER EXPRESS OR IMPLIED (INCLUDING WITHOUT LIMITATION WARRANTIES AS TO MERCHANTABILITY OR FITNESS FOR A PARTICULAR PURPOSE). Purchaser retains responsibility for the application and functional adequacy of the offering. In addition, the following shall constitute the exclusive remedies for any breach by Invensys Foxboro of its warranties hereunder.

MATERIAL, WORKMANSHIP, AND TITLE: Invensys Foxboro warrants to Purchaser that all products manufactured by Invensys Foxboro shall be free from defects in material, workmanship, and title, and agrees to either replace, or repair free of charge, any such product, component, or part thereof which shall be returned to the nearest authorized Invensys Foxboro repair facility within one (1) year from date of delivery transportation charges prepaid for the account of the Purchaser. The cost of demonstrating the need to diagnose such defects at the job site, if required, shall be for the account of the Purchaser. Any product or component, or part thereof, so replaced or repaired shall be warranted by Invensys Foxboro for the remainder of the original warranty period or three (3) months, whichever is longer. Any and all such replacements or repairs necessitated by inadequate preventative maintenance, or by normal wear and usage, or by the fault of the Purchaser or power sources supplied by others or by attack and deterioration under unsuitable environmental conditions shall be for the account of the Purchaser. Invensys Foxboro shall not be obligated to pay any costs or charges including "back charges" incurred by the Purchaser or any other party except as may be agreed upon in writing in advance by Invensys Foxboro.

Index

A

Alarm Contact Maintenance 83
Alarm Timers (HAtt, HAFt and HAdL) 35
Alarm Timers (LAtt, LAft, and LAdL) 39
Analog Output Calibration 55

B

Backup Sensor Operation 79
Basic Setup Entries 45
Battery Backup 4

C

Calibrating the Analyzer to a Specific Sensor 65
Calibration 59
Cell Factor 65
Changing the Analog Output 53
Changing the Full Scale Range (FSC) 46
Changing the Security Code (LCC) 57
Changing the Temperature Circuitry 47
Compensation and Damping (Cd) 31

D

Description 3
Determining (or Verifying) a CF 68
Determining tCF 66
Display 4, 19
Dual Sensor Use 77

E

Electronic Bench Calibration 59
Enclosures 3
Entering a CF Value 69
Entering a TCF Value 67
Error Codes 72

F

Features 3

G

General Information Alarms 31

H

H Alarm Configuration 33

I

Identification 5

Installation 9

J

Jumpers 53

K

Keypad 4, 20

L

L Alarm Configuration (LAC) 37

M

Mounting to a Panel 9

Mounting to a Pipe 11

Mounting to a Surface 14

Mounting to a Surface, Movable Mount 12

O

Operate Mode 22

Operation 19

Output #1's 0% Analog Value (LO1) 43

Output #1's 100% Analog Value (HO1) 43

Output #2's 0% Analog Value (L02) 44

Output #2's 100% Analog Value (H02) 43

R

Redundant Sensor Operation 78

RTD Temperature Calibration 51

S

Scaling Analog Outputs 42

Security Code 4

Setting Alarm Level(s) 32

Single Sensor Use 75
Specifications 6
Storm Door Option 4

T

Temp Key 22
Temperature Cell Factor 65
Thermistor Temperature Electronic Calibration 50
Troubleshooting 71

U

Unlocking Basic Setup Entries (bL) 46
User Notes 75
User-Defined Lower Measurement Limit (LL) 42
User-Defined Lower Temperature Limit (LtL) 42
User-Defined Upper Measurement Limit (UL) 41
User-Defined Upper Temperature Limit (UtL) 42

V

View Setup Entries 23

W

Warranty 85
Wiring of Metal Enclosure 17
Wiring of Plastic Enclosure 16

ISSUE DATES

MAR 1992
JUL 1995
JAN 1996
APR 1997
JUL 2001
JUN 2004
OCT 2005

Vertical lines to right of text or illustrations indicate areas changed at last issue date.

33 Commercial Street
Foxboro, MA 02035-2099
United States of America
<http://www.foxboro.com>
Inside U.S.: 1-866-746-6477
Outside U.S.: 1-508-549-2424
or contact your local Foxboro
Representative.
Facsimile: (508) 549-4492

Invensys, Foxboro, and I/A Series are trademarks of Invensys plc, its subsidiaries, and affiliates.
All other brand names may be trademarks of their respective owners.

Copyright 1992-2005 Invensys Systems, Inc.
All rights reserved

MB 123

Printed in U.S.A.

1005