

Instruction

MI 611-150

March 2006

**871EC Electrodeless Conductivity
Sensors and Accessories**

Installation and Maintenance

Contents

Figures.....	v
Tables.....	vii
1. Introduction	1
Dangers and Warnings	1
Reference Documents	2
Electrical Safety Specifications	3
Sensor Identification	6
Standard Specifications	6
Sensor Applications	9
Sensor Cell Factors	12
Sensor Model Code	13
2. Sensor Installation and Accessories	15
Installation Precautions	15
Notes For Small Bore Sensor Types	16
O-Ring Seals for Small Bore Sensors	17
O-Ring Seals for Large Bore Sensors	17
Ball Valve Assembly Installation	18
Installing the Ball Valve Assembly Into the Process	19
Connecting the Sensor to the Insertion Shaft Assembly	19
Installing the Insertion Shaft Into the Ball Valve	20
Removing and Replacing a Sensor	21
Flange Installation (All Sensor Types)	22
Flange Specifications	23
Installation Procedure	23
Bushing Installation (Sensor Types -TF, -SP, -NL, -HP, -PN, -PX, -PP, and -PT)	24
Bushing Specifications	24
Installation Procedure	24
Tri-Clamp Flange Installation	25
In Situ Installation	25
In-Line Installation	27
Junction Box Installation	28
Mounting	28
Wiring	28

3. Maintenance	31
Troubleshooting	31
Checking for Sensor Magnetization	32
Sensor Resistance Check	32
Appendix A. Temperature Compensation and Conductivity Reference Data	35
Index	37

Figures

- 1 Sensor Identification 6
- 2 Sensor Types -SP, -HP, -PP, -PT, -NL, -TF, -PN, and -PX O-ring Seals 17
- 3 Sensor Types -LB, -UT, -RE, -BW, -EV, and -AB O-ring Seals 17
- 4 Ball Valve Assembly 19
- 5 Assembly of Shaft Bushing to Sensor 19
- 6 Preassembly of Shaft Assembly 20
- 7 Ball Valve Assembly Shaft Installation and Removal 21
- 8 Typical Flange Installation 23
- 9 Typical Bushing Installations 25
- 10 Tri-Clamp Flange Installation 25
- 11 Typical In Situ Installation 26
- 12 Typical In-Line Installation 28
- 13 Junction Box Wiring 29
- 14 Sensor Magnetization Check 32
- 15 Sensor Cable Resistances 33

Tables

1	Sensor Applications - Standard Temperature PEEK - up to 120°C (250°F)	9
2	Sensor Applications - High Temperature PEEK - up to 200°C (392°F)	10
3	Sensor Applications - Non-PEEK Version	11
4	Sensor Cell Factors	12
5	Ball Valve Assembly Specifications	18
6	Flange Specifications	23
7	Hex Head Bushing Specifications	24
8	Minimum Pipe Diameters	27
9	Troubleshooting	31
10	Approximate Conductivity Values of Common Solutions	35

1. Introduction

The 871EC Sensors are used with 875EC Intelligent Analyzers, 870ITEC Intelligent Transmitters, 873EC and 873AEC Analyzers, and 870EC Transmitters. Sensors are available in a number of configurations and materials suitable for a variety of conditions.

The sensors measure an induced current in a loop of solution. Their patented proprietary design comprises two or three toroidally wound coils encapsulated within the sensor which is immersed in the solution. An ac signal, applied to one toroidal coil, induces a current in the second coil that is directly proportional to the conductance of the solution.

Dangers and Warnings

—  DANGER —

An electrical shock hazard may be present under sensor fault conditions when the sensor is located in process fluids at electrical potentials above 30 V rms or 60 V dc. In order to prevent electrical shock hazard, remove the sensor from the process or de-energize power to the process prior to performing maintenance on the transmitter or analyzer.

—  DANGER —

Electrical shock potential can be detected while the sensor is in a potentialized solution by removing the analyzer/transmitter field-terminal compartment cover and measuring between each of the sensor leads and ground (earth) with a voltmeter. If a potential above 30 V rms or 60 V dc is detected, an electrical shock hazard is present.

—  DANGER —

Certain units described in this instruction contain electrical shock hazard potential. Maintenance should be performed by qualified personnel only. During maintenance, remove power to avoid severe injury or death.

—  WARNING —

When performing maintenance, wear appropriate, protective clothing including safety goggles. Escaping chemicals under pressure can cause severe injury including blindness.

—  WARNING —

Use care when connecting and disconnecting high pressure service connections. Use proper gloves and follow the recommended procedures to avoid severe injury to personnel.

! WARNING

When processing hazardous liquids, follow the recommended procedures. Failure to do so could result in injury to personnel.

! WARNING

Use only Invensys Foxboro recommended replacement parts. Substitution parts could result in damage to equipment, damage to the process, and/or injury to personnel.

! WARNING

Be careful to avoid touching exposed circuits and components. Potential shock hazards are present.

Reference Documents

Document	Document Description
MI 611-156	Instruction – 870EC Transmitters (Electrodeless Conductivity)
MI 611-167	Instruction – 873EC Electrochemical Analyzers
MI 611-193	Instruction – 873AEC Ace Series Electrochemical Analyzers
MI 611-212	Instruction – 870ITEC Intelligent Electrochemical Transmitters
MI 611-220	Instruction – Electrodeless Conductivity System Calibration Examples
MI 611-224	Instruction – 875EC Intelligent Electrochemical Analyzers
DP 611-011	Dimensional Print – 871EC Electrodeless Conductivity Sensors
DP 611-092	Dimensional Print – Flanges (316 ss) used with 871CC, 871EC, 910, 920, and 1210 Conductivity Sensors
DP 611-105	Dimensional Print – Universal Mounting Bushing used with 871CC, 871EC, 910, 920, and 1210 Conductivity Sensors
DP 611-142	Dimensional Print – Ball Valve Assembly for Electrodeless Conductivity Sensors (871EC-PN and PX)
DP 611-155	Dimensional Print – Ball Valve Assembly for Electrodeless Conductivity Sensors (871EC--SP, -HP, -PP, -PT, -NL, and -TF)
TI 612-005	Electrodeless Conductivity, Toroidal Magnets and the Procedure of Degaussing

Electrical Safety Specifications

— NOTE —

These sensors have been designed to meet the electrical safety descriptions noted in the table above. For detailed information or status of testing laboratory approvals and certifications, contact Invensys Foxboro.

Testing Laboratory, Type of Protection, and Area Classification	Application Conditions	Electrical Safety Design Code
ATEX Certifications - 871EC Sensors with ATEX Certified Instruments		
ATEX Type ia, intrinsically safe for II 1 GD, EEx ia IIC, Zone 0.	Temperature Class T3-T6; T110°C - T260°C.	CS-E/AAA
ATEX Type n, energy limited for II 3 GD, EEx nL IIC, Zone 2.	Temperature Class T3-T6; T110°C - T260°C.	CS-E/ANN
CSA Certifications - 871EC Sensors with CSA Approved Instruments		
CSA ordinary locations.	Connect 871EC Sensor to approved instrument per MI 611-206.	CS-E/CAA CS-E/CNN
CSA intrinsically safe, Class I, II, III, Division 1, Groups A, B, C, D, E, F, G.	Connect 871EC Sensor to approved instrument per MI 611-206.	CS-E/CAA
CSA nonincendive, Class I, Division 2, Groups A, B, C, D; suitable for Class II, Div. 2, Groups E, F, G; and Class III, Div. 2.	Connect 871EC Sensor to approved instrument per MI 611-206.	CS-F/CNN
FM Approvals - 871EC Sensors with FM Approved Instruments		
FM ordinary locations.	Connect 871EC Sensor to approved instrument per MI 611-206.	CS-E/FAA CS-E/FNN
FM intrinsically safe, Class I, II, III, Division 1, Groups A, B, C, D, E, F, G.	Connect 871EC Sensor to approved instrument per MI 611-206.	CS-E/FAA
FM nonincendive, Class I, Division 2, Groups A, B, C, D; suitable for Class II, Div. 2, Groups F, G; and Class III, Div. 2.	Connect 871EC Sensor to approved instrument per MI 611-206.	CS-F/FNN

The following information shows which analyzers and transmitters can be used with a certified 871EC Sensor.

Testing Laboratory, Type of Protection, and Area Classification	Application Conditions	Electrical Safety Design Code
CSA Certifications - 875EC Analyzer with 871EC Sensors		
CSA ordinary locations.	Temperature Class T4A, Ta = 85°C maximum ambient. Connect to 875EC Transmitter per MI 611-206.	875EC-..C-.
CSA nonincendive, Class I, Division 2, Groups A, B, C, D; suitable for Class II, Div. 2, Groups E, F, G; and Class III, Div. 2.	Temperature Class T4A, Ta = 85°C maximum ambient. Connect to 875EC Transmitter per MI 611-206.	875EC-..C-.
CSA Certifications - 870ITEC Transmitter with 871EC Sensors		
CSA ordinary locations.	Temperature Class T4, Ta = 85°C maximum ambient. Connect to 870ITEC Transmitter per MI 611-206.	CS-E/CAA CS-E/CNZ
CSA intrinsically safe, Class I, II, III, Division 1, Groups A, B, C, D, E, F, G.	Temperature Class T4, Ta = 85°C maximum ambient. Connect to 870ITEC Transmitter per MI 611-206.	CS-E/CAA
CSA nonincendive, Class I, Division 2, Groups A, B, C, D; suitable for Class II, Div. 2, Groups F, G; and Class III, Div. 2.	Temperature Class T4, Ta = 85°C maximum ambient. Connect to 870ITEC Transmitter per MI 611-206.	CS-E/CNZ
CSA Certifications - 873EC and 873AEC Analyzers with 871EC Sensors		
CSA ordinary locations.	Connect to 873EC and 873AEC Analyzer per MI 611-206.	873EC-...CGZ- 873EC-...CNZ- .
CSA nonincendive, Class I, Division 2, Groups A, B, C, D; suitable for Class II, Div. 2, Groups F, G; and Class III, Div. 2.	Connect to 873EC and 873AEC Analyzer per MI 611-206.	873EC-...CNZ- .
CSA Certifications - 870EC Transmitter with 871EC Sensors		
CSA ordinary locations.	Connect to 870EC Transmitter per MI 611-206.	CS-E/CBA CS-E/CNA
CSA intrinsically safe, Class I, II, III, Division 1, Groups A, B, C, D, E, F, G.	Connect to 870EC Transmitter per MI 611-206.	CS-E/CBA
CSA nonincendive, Class I, Division 2, Groups A, B, C, D; suitable for Class II, Div. 2, Groups F, G; and Class III, Div. 2.	Connect to 870EC Transmitter per MI 611-206.	CS-E/CNA

Testing Laboratory, Type of Protection, and Area Classification	Application Conditions	Electrical Safety Design Code
FM Approvals - 875EC Analyzer with 871EC Sensors		
FM ordinary locations.	Temperature Class T4A, Ta = 75°C maximum ambient. Connect to 875EC Transmitter per MI 611-206.	875EC-..F-.
FM nonincendive, Class I, Division 2, Groups A, B, C, D; suitable for Class II, Div. 2, Groups F, G; and Class III, Div. 2.	Temperature Class T4A, Ta = 75°C maximum ambient. Connect to 875EC Transmitter per MI 611-206.	875EC-..F-.
FM Approvals - 870ITEC Transmitter with 871EC Sensors		
FM ordinary locations.	Temperature Class T4, Ta = 85°C maximum ambient. Connect to 870ITEC Transmitter per MI 611-206.	CS-E/FAA CS-E/FNZ
FM intrinsically safe, Class I, II, III, Division 1, Groups A, B, C, D, E, F, G.	Temperature Class T4, Ta = 85°C maximum ambient. Connect to 870ITEC Transmitter per MI 611-206.	CS-E/FAA
FM nonincendive, Class I, Division 2, Groups A, B, C, D; suitable for Class II, Div. 2, Groups F, G; and Class III, Div. 2.	Temperature Class T4, Ta = 85°C maximum ambient. Connect to 870ITEC Transmitter per MI 611-206.	CS-E/FNZ
FM Approvals - 873EC Analyzer with 871EC Sensors		
FM ordinary locations.	Connect to 873EC Analyzer per MI 611-206.	873EC-...FGZ-. 873EC-...FNZ-.
FM nonincendive, Class I, Division 2, Groups A, B, C, D; suitable for Class II, Div. 2, Groups F, G; and Class III, Div. 2.	Connect to 873EC Analyzer per MI 611-206.	873EC-...FNZ-.
FM Approvals - 870EC Transmitter with 871EC Sensors		
FM ordinary locations.	Connect to 870EC Transmitter per MI 611-206.	CS-E/FBA CS-E/FNA
FM intrinsically safe, Class I, II, III, Division 1, Groups A, B, C, D, E, F, G.	Connect to 870EC Transmitter per MI 611-206.	CS-E/FBA
FM nonincendive, Class I, Division 2, Groups A, B, C, D; suitable for Class II, Div. 2, Groups F, G; and Class III, Div. 2.	Connect to 870EC Transmitter per MI 611-206.	CS-E/FNA

Sensor Identification

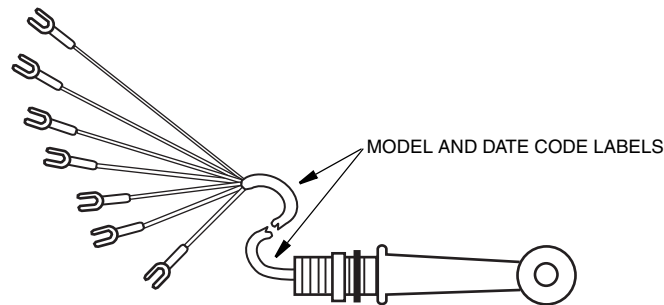

Figure 1. Sensor Identification

Standard Specifications

A sensor can be identified by the model code located on both ends of the sensor cable (see Figure 1). Refer to “Sensor Applications” on page 9 for sensor application information.

Wetted Parts

See “Sensor Measurement Limits, Materials, Temperature Limits, Pressure Limits, and Temperature Compensator” on page 7.

Cable

Integral, 6 m (20 ft) multi-screened (multi-shielded) cable with the following jacket material:

- ◆ For -SP, -NL, -TF, -RE, -LB, and -EV; irradiated polyolefin jacket
- ◆ For -HP, -BW, and -UT; ptfe jacket

Mounting

Pipe thread types supplied with various sensors are listed below.

Sensor Type	Pipe Thread Type
871EC-REO, -BWO, -LBO, -UTO	3/4-14 NPT (National Pipe Thread), Tapered
871EC-SPO, -HPO, -PPO, -PTO, -NLO, -SP7, -HP7, -PT7, -PP7	3/4-14 NPSM (National Straight Pipe Thread for Free Fitting Mechanical Joints) truncated to 0.990/0.975 in O.D.
871EC-TF2, -TF3, -TF7, -EV3, -PN3, -PXO, -AB3,	3/4-14 NPT (National Pipe Thread), Tapered

Insertion Mounting: Sensors are used with threaded bushings or flanges that form a process seal against the sensor O-ring.

In situ Mounting: Mate to a user-supplied 3/4-in coupling and length of DN20 or 3/4-in pipe.

Ball Valve Mounting: Sensors are used with ball valve assemblies that contain connections for mating to the sensor.

— **NOTE** —

When mounted in-line, the sensors must be installed (centered) in the minimum pipe sizes listed below to avoid pipe wall effects:

For -SP, -HP, -PP, -PT, -NL, -TF, -PN, and -PX; DN 80 (3 in)

For -RE, -BW, -LB, -UT, -EV, and AB; DN 150 (6 in)

Electromagnetic Compatibility (EMC)

The 871EC Electrodeless Conductivity Sensor complies with the requirements of the European EMC Directive 89/336/EEC when its cable is connected through rigid metal conduit as recommended for 873EC*, 873AEC*, and 875EC Analyzers, and 870ITEC Transmitters. (*220 V ac, 240 V ac metal enclosures only)

Sensor Measurement Limits, Materials, Temperature Limits, Pressure Limits, and Temperature Compensator

Sensor Body Code (a)	Full Scale Measurement Limits (min/max)	Wetted Parts	Temperature Limits	Pressure Limits	Temperature Element (Integral)
Standard Temperature PEEK - up to 120°C (250°F)					
-SP	1.0 mS/cm (1000 μS/cm) minimum ^(b) ; 2000 mS/cm maximum	Glass-filled PEEK (Polyetheretherketone), EPDM, Viton, Kalrez, or Chemraz O-rings, as specified	-5 and +120°C (20 and 250°F)	-0.1 and +1.75 MPa (-15 and +250 psi)	100 kΩ thermistor for use with 873EC, 875EC, and 873AEC Analyzers or 870ITEC and 870EC Transmitters.
-RE	1.0 mS/cm (1000 μS/cm) minimum ^(b) ; 1000 mS/cm maximum			-0.1 and +2.41 MPa (-15 and +350 psi)	
-LB	0.05 mS/cm (50 μS/cm) minimum ^(b) ; 50 mS/cm maximum				
High Temperature PEEK - up to 200°C (390°F)					
-HP	1.0 mS/cm (1000 μS/cm) minimum ^(b) ; 2000 mS/cm maximum	Glass-filled PEEK (Polyetheretherketone); EPDM, Viton, Kalrez, or Chemraz O-rings, as specified	-5 and +200°C (20 and 392°F)	-0.1 and +1.75 MPa (-15 and +250 psi)	100 Ω platinum RTD for use with 875EC and 873EC Analyzers, and 870ITEC Transmitters
-BW	1.0 mS/cm (1000 μS/cm) minimum ^(b) ; 1000 mS/cm maximum			-0.1 and +2.41 MPa (-15 and +350 psi)	
-UT	0.05 mS/cm (50 μS/cm) minimum ^(b) ; 50 mS/cm maximum				

TABLE CONTINUES ON NEXT PAGE.

Sensor Body Code (a)	Full Scale Measurement Limits (min/max)	Wetted Parts	Temperature Limits	Pressure Limits	Temperature Element (Integral)
Non-PEEK Versions					
-PT	1.0 mS/cm (1000 μ S/cm) minimum ^(b) ; 2000 mS/cm maximum	Virgin polypropylene, EPDM, Viton, Kalrez, or Chemraz O-ring as specified	-5 and +120°C (20 and 250°F) ^(c)	-0.1 and +1.4 MPa (-15 and +200 psi)	100 k Ω thermistor for use with 873EC, 875EC, and 873AEC Analyzers and 870ITEC and 870EC Transmitters ^(d)
-PP	1.0 mS/cm (1000 μ S/cm) minimum (b); 2000 mS/cm maximum.				100 Ω platinum RTD for use with 875EC and 873EC Analyzers, and 870ITEC Transmitters
-NL	1.0 mS/cm (1000 μ S/cm) minimum ^(b) ; 2000 mS/cm maximum	Glass-filled Noryl; EPDM O-rings	-5 and +65°C (20 and 150°F)		100 k Ω thermistor for use with 873EC, 873AEC, and 875EC Analyzers and 870ITEC and 870EC Transmitters ^(c)
-PN	1.0 mS/cm (1000 μ S/cm) minimum; 2000 mS/cm maximum	Glass-filled Noryl; 316 ss extension; EPDM or Viton O-rings as specified	-5 and +105°C (20 and 225°F)		
-PX	1.0 mS/cm (1000 μ S/cm) minimum; 2000 mS/cm maximum	Glass-filled Noryl; GF Noryl extension; EPDM or Viton O-rings as specified			
-TF	1.0 mS/cm (1000 μ S/cm) minimum ^(b) ; 2000 mS/cm maximum	Fluorocarbon head; 316 ss or Carpenter 20 Cb ^(e) housing as specified; EPDM, Viton ^(f) , Kalrez, or Chemraz O-rings, as specified			
-EV	0.2 mS/cm (200 μ S/cm) minimum ^(b) ; 2000 mS/cm maximum ^(g)	Epoxy head; 316 ss extension; EPDM O-rings		-0.1 and +0.7 MPa (-15 and +100 psi)	
-AB	2.0 mS/cm (2000 μ S/cm) minimum; 500 mS/cm maximum	Linatex (natural rubber); 316 ss extension; EPDM or Viton O-rings as specified	-5 and +65°C (20 and 150°F)		

(a) In process fluids operating at electrical potentials above 30 V rms or 60 V dc, refer to Foxboro for applicable sensor.

(b) These minimum spans are for sensors used with 875EC, 873EC, and 873AEC Analyzers and 870ITEC Transmitters. For minimum spans for sensors used with 870EC Transmitters, refer to ranges given in PSS 6-3C3 A.

(c) 1.4 MPa at 80°C (200 psi at 176°F) is linearly derated to 1.05 MPa at 120°C (150 psi at 250°F)

(d) If -HP, -BW, -UT, or -PT sensor is used with an 870EC Transmitter, no temperature compensation can be applied.

(e) For sulfuric acid (99.5 to 93%) and oleum ranges, use optional Carpenter 20 Cb mounting extension.

(f) For sulfuric acid (99.5 to 93%), oleum ranges, and petroleum applications, use optional Viton O-rings

(g) Maximum span for -EV sensor when used with 873EC Analyzer is 1000 mS/cm.

Sensor Applications

— NOTE —

1. PEEK is a thermoplastic material with excellent strength and chemical resistance properties over a wide range of process temperatures and pressures. Foxboro recommends using PEEK preferentially for all applications that qualify.
 2. PEEK material displays excellent chemical resistance to most aqueous solutions of acids, bases, and salts. It is also excellent for organic solvents such as toluene, ethyl acetate, acetone, gasoline, and carbon tetrachloride. It is not recommended for concentrations of sulfuric or nitric acid above 40%, nor for hydrofluoric acid or oleum applications. Contact Foxboro for appropriate sensor(s).
 3. Virgin polypropylene provides excellent chemical resistance for applications such as HF, KCl or KOH.
-

Table 1. Sensor Applications - Standard Temperature PEEK - up to 120°C (250°F)







Sensor Body Code(a)	Application(a)	Sensor
-SP	This small bore sensor is suitable for the majority of all electrodeless conductivity applications. Its compact size enables it to be mounted in a multitude of methods, including insertion (flange, bushing), retractable, and in situ. Typical applications include salinity and brine measurements, steel pickling, scrubbing towers, ion exchange regeneration, plating baths, rinse water, caustic metal cleaning, and textile measurements in scouring, mercerizing, and carbonizing baths.	
-RE	This large bore sensor is recommended as a substitute for 871EC-EV Series sensors, both for new and existing installations. Its large bore makes it particularly suitable for measurements with very high levels of fouling materials, such as limestone. Pulp and paper applications include brown stock washing (filtrate) and paper machine (white water). Additional applications include lye peeling of fruits and vegetables, oil well drilling (mud-logging), waste stream monitoring, and spill detection.	

Table 1. Sensor Applications - Standard Temperature PEEK - up to 120°C (250°F) (Continued)

Sensor Body Code(a)	Application(a)	Sensor
-LB	This large bore sensor is used for low conductivity measurements where a sensitive range is required. It is often used in place of a conventional contacting conductivity measurement system to reduce maintenance, since fouling from oil, water treatment chemicals, particulates, etc., renders a contacting sensor inoperative. Typical applications involve water quality measurements such as boiler feedwater, steam condensate, rinse water, boiler blowdown, heat exchanger leakage, stream pollution, cooling towers, and evaporators.	

(a) In process fluids operating at electrical potentials above 30 V rms or 60 V dc, contact Foxboro.

Table 2. Sensor Applications - High Temperature PEEK - up to 200°C (392°F)

Sensor Body Code(a)	Application(a)	Sensor
-HP	This small bore sensor is identical in physical size and appearance to the -SP sensor and may be applied to any of the -SP applications identified which have intermittent or continuously high temperatures. Additional high temperature applications for which this sensor is suited include alumina-to-caustic ratio in Bayer plants, boiler blowdown, and clean-in-place (CIP) measurements in food and related industries (-HP7).	
-BW	This highly specialized, large bore sensor is intended for use in applications with a combination of both high temperatures and very high levels of fouling materials. Application areas overlap with those listed for the type -HP sensor. Additional applications include pulp and paper measurements in green liquor (dissolving tank), first and second causticizer, and white and black liquor (digester).	
-UT	This large bore sensor is identical in physical size and appearance to the -LB sensor. Applications for this sensor are generically the same as those identified for the -LB unit (e.g., low conductivity), except that the -UT sensor should be specified for situations where high temperatures may be present, either intermittently or continuously.	

(a) In process fluids operating at electrical potentials above 30 V rms or 60 V dc, contact Foxboro.

Table 3. Sensor Applications - Non-PEEK Version









Sensor Body Code(a)	Application(a)	Sensor
-PT	This small bore sensor is suitable for many of the applications typically addressed by the -SP sensor and those for which it is uniquely suitable (for example, HF, KCl, KOH).	
-PP	This small bore sensor is suitable for any of the applications typically addressed by the -SP sensor and those for which it is uniquely suitable (for example, HF, KCl, KOH).	
-NL	This general purpose, small bore sensor may be used for most routine applications involving low (<5%) concentrations of inorganic acids (hydrochloric, nitric, sulfuric, etc.), bases (caustic, calcium hydroxide, etc.), and salts (sodium chloride, calcium chloride, sodium sulfate, etc.). Not recommended where organic solvents are present. Not recommended in caustic applications above 50°C (122°F). When doubtful about the effect of high levels of chemicals, temperatures, or abrasion on the -NL sensor, specify a type -SP PEEK sensor as a preferred alternative.	
-PN	This sensor is used for most general purpose and acidic applications where a 316 ss mounting extension is acceptable. It is not, however, recommended for use in caustic installations.	
-PX	This sensor is similar to the -PN sensor in that it is also used for most general purpose and acidic applications, however, where a glass-filled Noryl extension is acceptable. The -PX is also not recommended for use in caustic installations.	
-TF	Used in oleum and concentrated (>90%) sulfuric acid applications. Used in the food and pharmaceutical industries when a sanitary mounting fitting (code 7) is required. For alternative sanitary mounting sensor(s), consider -SP7, -HP7, -PT7, or -PP7 sensors (316 ss, 50 mm (2 in) Tri-Clamp fitting).	

Table 3. Sensor Applications - Non-PEEK Version (Continued)

Sensor Body Code(a)	Application(a)	Sensor
-EV	This large bore sensor has been superseded by PEEK sensor type -RE. However, it may still be specified in beet sugar carbonation applications and in mining applications such as copper flotation, where highly abrasive slurries are present.	
-AB	This specialized large bore sensor is similar to sensor type -EV. It has a highly abrasion-resistant coating which is suitable for use in slurry and other abrasive applications.	

(a) In process fluids operating at electrical potentials above 30 V rms or 60 V dc, contact Foxboro for applicable sensor.

Sensor Cell Factors

Refer to Table 4 to determine the cell factor for a particular sensor.

Table 4. Sensor Cell Factors

Type of 871EC Sensor	Cell Factor
-SP, -HP	2.15
-PP, -PT	2.185
-RE, -LB, -UT, -BW	0.873
-TF	2.31
-NL	2.35
-PN, -PX	2.45
-EV	0.45
-AB	0.588

Sensor Model Code

Description	Model		
Electrodeless Conductivity Sensor	871EC		
Sensor Body Material, Temperature Limits, and Thermistor or RTD			
Sensor Body Material	Temperature Limits	Temp. Element	
PEEK, Small Bore	-5 and +120°C (20 and 250°F)	100 kΩ Thermistor	-SP
PEEK, Large Bore (Wide Range)	-5 and +120°C (20 and 250°F)	100 kΩ Thermistor	-RE
PEEK, Large Bore (High Sensitivity)	-5 and +120°C (20 and 250°F)	100 kΩ Thermistor	-LB
PEEK, Small Bore	-5 and +200°C (20 and 390°F)	100 Ω RTD	-HP
PEEK, Large Bore (Wide Range)	-5 and +200°C (20 and 390°F)	100 Ω RTD	-BW
PEEK, Large Bore (High Sensitivity)	-5 and +200°C (20 and 390°F)	100 Ω RTD	-UT
Noryl	-5 and +65°C (20 and 150°F)	100 kΩ Thermistor	-NL
Linatex (Natural Rubber)	-5 and +65°C (20 and 150°F)	100 kΩ Thermistor	-AB
Fluorocarbon	-5 and +105°C (20 and 225°F)	100 kΩ Thermistor	-TF
Epoxy	-5 and +105°C (20 and 225°F)	100 kΩ Thermistor	-EV
Virgin Polypropylene, Small Bore	-5 and +120°C (20 and 250°F)(a)	100 Ω RTD	-PP
Virgin Polypropylene, Small Bore	-5 and +120°C (20 and 250°F)(a)	100 kΩ Thermistor	-PT
Sensor Wetted Metallic and Mounting Parts			
None - Universal Mount			0
Used with Sensor Codes -SP, -HP, -LB, -UT, -RE, -BW, -NL, -PX, -PP, and -PT only			
Carpenter 20 Cb - Universal Mount			2
Used with Sensor Code -TF only			
316 ss - Universal Mount			3
Used with Sensor Codes -AB, -EV, -TF, and -PN only			
316 ss Sanitary Mounting Fitting, 2-inch Tri-Clamp (b)			7
Used with Sensor Codes -SP, -HP, -PP, -PT, and -TF only			
Optional Selections			
Cable Options			
Nonstandard Integral Cable; specify length from 1 to 30 m (3 to 100 ft) (c)			-3
Standard cable length is 6 m (20 ft)			
Not available with Option -5			
Pin Lug cable termination (d)			-4
Not available with Options -5, -6, and -7			
Nonstandard Integral Cable terminated in a connector plug (c)(e)(f)			-5
Specify length from 1 to 30 m (3 to 100 ft)			
Not available with Options -3, -4, -6 and -7			
Connector Integral to Sensor (b)(d)(f)			-6
Not available with Options -3, -4, -5, and -7			
Standard length, 6 m (20 ft), integral cable terminated in a connector plug (c)(e)			-7
Not available with Options -3, -4, -5, and -6			
Integral Low Smoke Cable; specify length from 1 to 30 m (3 to 100 ft) (c)(d)(f)			-N

<p>Optional Selections (Cont.)</p> <p>O-Ring Options</p> <p>(Available with Sensor Codes -SP, -HP, -LB, -UT, -RE, -BW, -TF, -PP, and -PT only)</p> <p>Chemraz O-rings</p> <p>Kalrez O-rings</p> <p>Viton O-rings</p> <p>Example: 871EC-SP0-34V</p>	<p>-C</p> <p>-K</p> <p>-V</p>
--	-------------------------------

- (a) The -PP and -PT sensor temperatures are listed at 1.05 MPa (150 psi). The temperatures are linearly derated to 80°C (176°F) at a higher pressure of 1.4 MPa (200 psi).
- (b) 2 in 316ss Tri-Clamp: Removable adapter for Sensor Codes -SP7, -HP7, -PP7, and -PT7; integral mounting fitting for Sensor Code -TF7.
- (c) Include the patch cable and integral cable lengths when calculating the overall cable length for Options -5, -6, and -7.
- (d) All cables, not terminated with connectors or spade lugs, do have leads terminated with straight pin lugs and are compatible with all Foxboro Analyzers and Transmitters.
- (e) A patch cable is required with Options -5, -6, and -7. For these options, use:
- For Sensors -AB, -EV, -PN, -PX, -TF, -NL, -SP, -LB, -RE, -PP, and -PT, and low temperature applications up to 125°C (257°F)
 - Patch Cable Part No. BS811RL: Standard length of 6 m (20 ft)
 - Patch Cable Part No. BS811RM: Length per Sales Order up to 30 m (100 ft).
 - For Sensors -HP, -UT, -BW, and high temperature applications up to 200°C (390°F)
 - Patch Cable Part No. BS811RJ: Standard length of 6 m (20 ft)
 - Patch Cable Part No. BS811RK: Length per Sales Order up to 30 m (100 ft).
 - For applications requiring Low Smoke Cable and temperatures up to 90°C (194°F)
 - Patch Cable Part No. BS811RN: Standard length of 6 m (20 ft)
 - Patch Cable Part No. BS811RP: Length per Sales Order up to 30 m (100 ft).
- (f) Contact Invensys Foxboro.

2. Sensor Installation and Accessories

Proper installation of the sensor is important for efficient and accurate operation.

For all applications and sensor configurations, mounting arrangements must be located so that:

- ◆ Sample at the sensing area is representative of the solution.
- ◆ Position and orientation of the sensor does not trap air bubbles within sensing area.

If the sensor cable is installed in metal conduit (recommended), either flexible conduit should be used or some other provision made for removal of sensor from the process.

Lubricate all O-rings with a thin film of suitable grease.

Installation Precautions

— **WARNING** —

Use care to avoid contact with process solution when installing, removing, or calibrating electrodeless sensors. Many of the solutions serviced by these sensors are very aggressive, and contact with them can cause personal injury or even death.

1. Maximum recommended flow rate for these sensors is 3.05 m/s (10 ft/s). Although greater flow rates will not damage the sensor, they cause an increased likelihood of cavitation (air pockets) which can result in a noisy signal.
2. For applications requiring high accuracy (for example, percent concentration measurement), avoid mounting the sensor head close to solid surfaces. Make certain the sensor is centered in pipe having **at least** the inner diameter specified in Table 8 on page 27. (This is less critical in applications, such as interface detection, that require only an indication of significant conductivity changes).
3. Avoid locating the sensor close to sources of strong magnetic fields (such as electric motors) which can magnetize the sensor. A magnetized sensor will generally result in low measurement values, especially when using sensors for low conductivity ranges. For information on degaussing a magnetized sensor, see TI 612-005.
4. To avoid any interaction between sensors, a minimum installation distance of 460 mm (18 in) between them is recommended.
5. Maximum recommended cable length is 30.5 m (100 ft). Longer cable lengths can result in reduced sensor accuracy; primarily due to degradation of temperature measurement. Standard cable length is 6.1 m (20 ft) with optional lengths of up to 30.5 m (100 ft).
6. Any external cable extensions, up to the recommended overall maximum of 30.5 m (100 ft), should be accomplished via NEMA 4X rated junction boxes and should have good quality connections. Do **not** use wire nuts and avoid solder connections when

- possible. Also, use only Invensys Foxboro extension cables that were designed for use with 871EC Sensors. There are no equivalent cables from Belden or other suppliers.
7. When using extended lengths of cable, a complete calibration, including temperature verification, should be performed with the additional cables installed.
 8. The O-ring located at the cable end of the sensor provides a process seal when used in bushing or flange installations. Make certain that the O-ring material, as specified in the sales order, is compatible with the process fluid. Also make certain that the O-ring is not twisted, kinked or damaged prior to installation.
 9. The RTV seal provided at the cable end of the sensor prevents ingress of *non-caustic* solutions such as water. For *caustic* solutions, such as NaOH, which can degrade the RTV seal, use of additional sealant, suitable for the application, is recommended.
 10. -TF sensors (for example, 871EC-TF2) have two O-ring seals. Only the O-ring at the cable end of the sensor is replaceable.
 11. The second O-ring on -TF sensors is not field-replaceable. For example, a 871EC-TF2 Sensor cannot be converted to a 871EC-TF2-V Sensor by replacing the EPDM O-ring with a Viton O-ring.
 12. These sensors are highly sensitive devices that will detect even a thin film which will affect calibration results. They, therefore, should be clean and dry before being calibrated.

Notes For Small Bore Sensor Types

This section applies to sensor types -SP, -HP, -PP, -PT, -NL, -TF, -PN, and -PX.

— NOTE —

1. An O-ring is in place near the cable end of the sensor.
 2. Ensure that the sensor received has the O-ring in the proper position, without nicks, and is not twisted.
 3. Ensure that future O-ring replacement is in the proper position and not twisted.
-

— WARNING —

Incorrect O-ring positioning, as previously indicated, could result in process leakage, causing injury or death of personnel.

O-Ring Seals for Small Bore Sensors

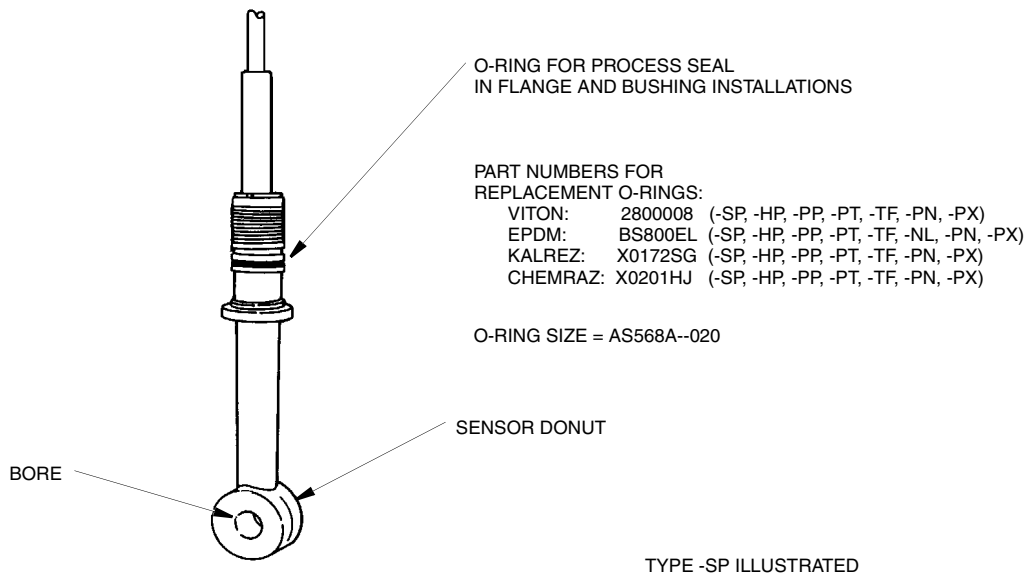

Figure 2. Sensor Types -SP, -HP, -PP, -PT, -NL, -TF, -PN, and -PX O-ring Seals

NOTE

Sensor Types -TF, and -PN also have an inner O-ring that is not accessible.

O-Ring Seals for Large Bore Sensors

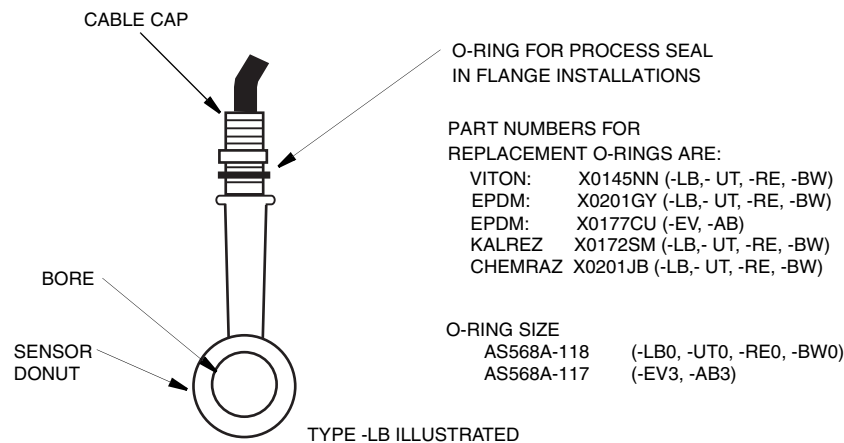

Figure 3. Sensor Types -LB, -UT, -RE, -BW, -EV, and -AB O-ring Seals

NOTE

There are two notches at the cable cap that line up with the flat edges of the sensor “donut”. These notches are an aid in positioning the sensor in a pipe or vessel. For example, you may choose to direct flow **through** the sensor bore.

Ball Valve Assembly Installation

— NOTE —

1. Sensor types -SP, -HP, -PP, -PT, -NL, and -TF use 2 NPT ball valves. Sensor types -RE, -LB, -BW, and -UT uses a 3 NPT ball valve. Sensor type -PN uses a 1 1/2 NPT ball valve. See Table 5.
2. The purgeable ball valve assembly provides for two 1/4 NPT connections to allow purging of dirty solutions, high suspended solids, and so forth, before insertion of the sensor and during operation. Some assemblies have both connections facing in the same direction; others have the connections facing opposite directions.

— ⚠ WARNING —

When you use high temperature PEEK sensors (871EC-HP, -BW) for digester liquor measurements in pulp and paper processes, a ball valve installation is **not recommended**. Instead, use a metal bushing or an ANSI Class 300 Flange or the 871FT Industrial Flow-Through Conductivity Sensor.

The ball valve assembly permits sensors to be removed from a process stream or tank under rated temperature and pressure without draining the system or resorting to a bypass arrangement. The assembly consists of the ball valve unit and a shaft assembly. Standard flexible conduit (user provided) can be used for cable protection.

A ball valve assembly installation must meet mounting arrangements specified under “Sensor Mounting” section, as well as the following requirements:

1. Direct the flow of the solution (as much as possible) toward the sensing area.
2. Provide a space for removal of the sensor in the ball valve unit, see DP 611-155 (for -SP, -HP, -PP, -PT, -NL), DP 611-156 (for -TF), DP 611-180 (for -RE, -BW, -LB, -UT), and DP 611-142 (for -PN).
3. Refer to Table 5 for ball valve specifications.

Table 5. Ball Valve Assembly Specifications

Process Line Conn. (in)	Foxboro Part No.		Material of Processed Wetted Parts				Rated Pressure ^(a)		Maximum Temperature at Rated Pressure ^(a)		Used with 871EC Body Codes
	Purgeable Housing	Non-purgeable Housing	Process Conn. and Housing	Ball Seat	Ball Valve	O-Ring	Mpa	psi	°C	°F	
2 NPT (full port)	BS805JV	BS805JU	316 ss	ptfe	316 ss	EPDM	1.4	200	150	300	-TF, -SP, -NL, -HP, -PP, -PT
2 NPT (full port)	BS805HX	--	316 ss	ptfe	poly-propylene	EPDM	0.7 0.4 0.27	100 60 40	20 65 95	70 150 200	-TF, -SP, -NL, -HP, -PP, -PT
3 NPT (full port)	BS806GE	--	316 ss	ptfe	316 ss	EPDM	2.1 0.7	300 100	177 200	350 390	-RE, -LB -BW, -UT
1 1/2 NPT (full port)	BS805JS	BS805JR	316 ss	ptfe	316 ss	EPDM	0.9 0.5 0.3	125 70 50	20 65 95	70 150 200	-PN

(a) Actual application rating may be reduced by Sensor Pressure-Temperature rating.

Installing the Ball Valve Assembly Into the Process

1. Unscrew the housing nut and remove the insertion shaft assembly.
2. Close the ball valve by turning the handle so that it is perpendicular to the housing (as indicated by the arrow on top of the handle).
3. Screw the NPT nipple of the ball valve into the process vessel. Tighten as required.

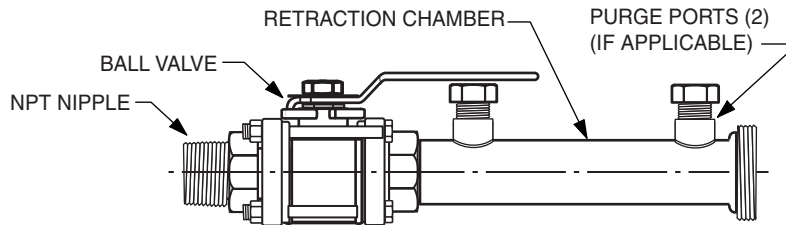

Figure 4. Ball Valve Assembly

4. Connect appropriate piping to the purge ports of the retraction chamber (if applicable).

Connecting the Sensor to the Insertion Shaft Assembly

1. Feed the sensor cable through the shaft bushing assembly and the shaft assembly. Screw the shaft bushing assembly onto the sensor. Tighten the set screws to the 3/4 NPT end of the sensor. (see Figure 5)

CAUTION
Do not overtighten the set screws.

2. Wrap Teflon[®] tape onto the threads of the shaft nut. Screw the shaft assembly onto the shaft bushing assembly.

NOTE
To prevent the cable from twisting, it is recommended that this be done by holding the sensor and turning the insertion shaft.

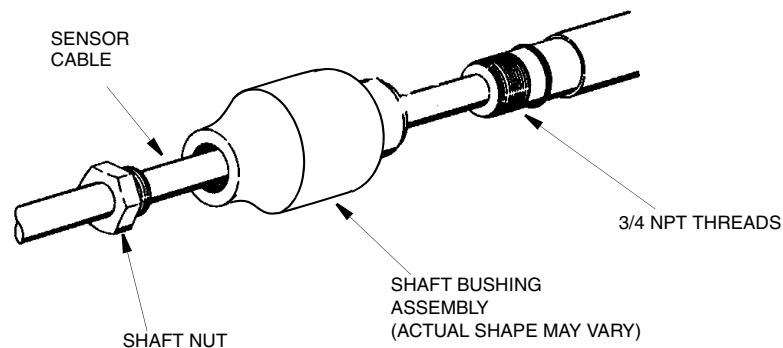

Figure 5. Assembly of Shaft Bushing to Sensor

3. Make sure the shaft assembly is preassembled as shown in Figure 6.
4. Lightly lubricate the shaft with silicone grease (or equivalent).

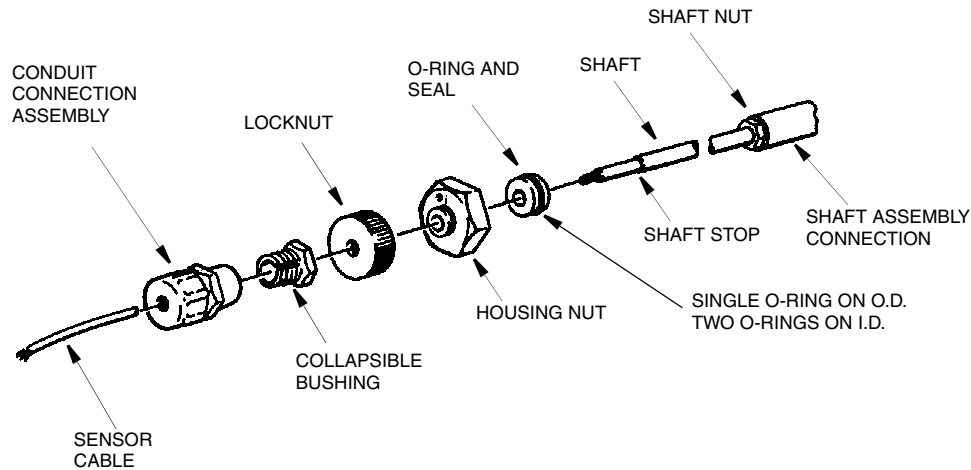

Figure 6. Preassembly of Shaft Assembly

Installing the Insertion Shaft Into the Ball Valve

— **! WARNING** —
Do not exceed the sensor or ball valve temperature and pressure limits.

— **! WARNING** —
Stand to the side, not directly behind the assembly, during insertion of the sensor.

— **NOTE** —
The sensor should have been connected to the insertion shaft assembly prior to performing this procedure. See “Connecting the Sensor to the Insertion Shaft Assembly” on page 19

1. Assure that the ball valve is closed. The handle should be perpendicular to the housing (as indicated by the arrow on top of the handle).
2. Fill and pressurize the process line or tank as required. Check for and eliminate leaks.
3. Lightly lubricate the shaft with silicone grease (or equivalent).
4. Slide the O-ring and seal along the insertion shaft towards the sensor as far as it goes.

— **! CAUTION** —
Failure to do this makes it possible for the sensor to contact the closed ball valve when performing the next step. Such contact could damage the sensor.

5. Carefully insert the sensor (connected to the insertion shaft assembly) into the housing retraction chamber until the O-ring and seal are seated into the end of the chamber (see Figure 7).

CAUTION
Do not nick the O-rings. Do not force the sensor against the closed ball valve.

6. Tighten the housing nut onto the end of the retraction chamber.

NOTE
The housing nut is supplied lubricated. It should be relubricated periodically to prevent galling.

7. Slowly turn the handle on top of the ball valve unit to the open position (parallel to the housing as indicated by an arrow on top of the handle).

WARNING
Depending on the condition of the seal, process seepage is possible as you perform the next step.

CAUTION
Failure to open the ball valve causes the sensor to contact the closed ball valve when performing the next step. Such contact could damage the sensor.

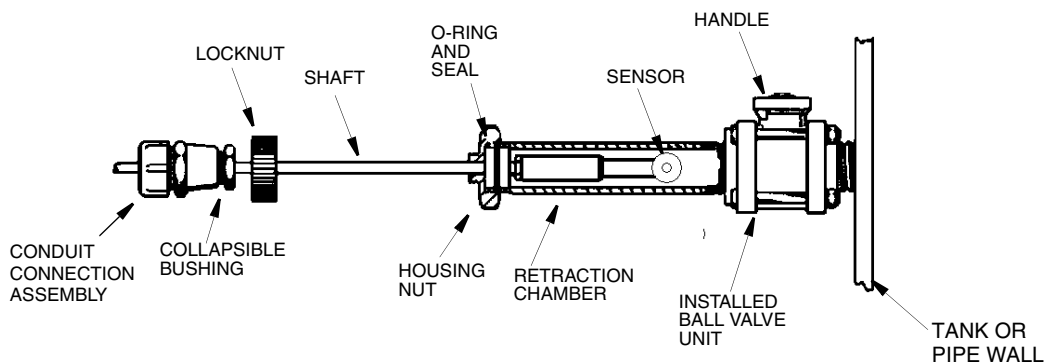

Figure 7. Ball Valve Assembly Shaft Installation and Removal

8. Insert the shaft slowly until the locknut reaches the housing nut. Tighten the locknut onto the housing nut.
9. Push the collapsible bushing against the locknut.
10. Assemble the conduit connection assembly to the collapsible bushing.

Removing and Replacing a Sensor

WARNING
Stand to the side, not directly behind the assembly, during insertion of the sensor.

! WARNING

If process fluid is present, there could be some process seepage as you perform Steps 2 and 5. Take all necessary precautions.

! WARNING

Do not loosen the **housing nut** (see Figure 7) when the ball valve unit is open and the process line or tank is filled and pressurized. Severe injury to personnel may result.

1. Carefully loosen and detach the locknut **only**. Do **not** loosen the housing nut at this time.
2. Pull the insertion shaft out of the process as far as you can. This positions the sensor in the retraction chamber.
3. Close the ball valve by turning the handle so that it is perpendicular to the housing (as indicated by the arrow on top of the handle).
4. Flush and drain the purgeable retraction chamber (if applicable). Then close the purge fittings.
5. Slowly loosen and detach the housing nut. Withdraw the shaft assembly from the housing retraction chamber.
6. Remove the conduit connection assembly from the insertion shaft.
7. Unscrew and remove the sensor from the insertion shaft.
8. Perform “Connecting the Sensor to the Insertion Shaft Assembly” on page 19.
9. Perform “Installing the Insertion Shaft Into the Ball Valve” on page 20.

Flange Installation (All Sensor Types)

Invensys Foxboro flanges are used for permanent installations in pipelines and tanks. Flanges are used with electrodeless conductivity sensors in systems using 2-inch and larger process piping. Flanges come complete with locknut and one or more spacers.

NOTE

1. One or more spacers are used depending on flange thickness. The O-ring must be positioned correctly for proper spacing.
 2. If the sensor will be exposed to moisture (for example, rain, hosing, or condensation), the cable end of the sensor should be further protected. Refer to “In Situ Installation” on page 25 and perform Steps 1 through 9; replace support pipe with appropriate electrical conduit.
 3. If an 871EC-HP or -BW Sensor is to be installed in a digester line in the pulp and paper industry, the use of an ANSI Class 300 Flange (**not** an MSS-SP-51 Class 150LW Flange) is recommended.
-

Flange Specifications

Table 6. Flange Specifications

Flange Size*	Foxboro Part	Flange Material	Used With 871EC Sensor Body Codes
2 in ^(a)	0051199	316 ss	-SP, -HP, -PP, -PT, -TF, -NL, -PN, -PX
2 in ^(b)	BS805PL	316 ss	-SP, -HP, -PP, -PT, -TF, -NL, -PN, -PX
DN 50 ^(c)	BS805JL	316 ss	-SP, -HP, -PP, -PT, -TF, -NL, -PN, -PX
2 1/2 in ^(a)	0051196	316 ss	-SP, -HP, -PP, -PT, -TF, -NL, -PN, -PX
3 in ^(a)	0051197	316 ss	-SP, -HP, -PP, -PT, -TF, -NL, -PN, -PX
3 in ^(b)	BS805PM	316 ss	-SP, -HP, -PP, -PT, -TF, -NL, -PN, -PX
4 in ^(a)	0051198	316 ss	-SP, -HP, -PP, -PT, -TF, -NL, -EV, -AB, -PN, -PX
4 in ^(a)	BS805XQ	316 ss	-RE, -LB, -BW, -UT
4 in ^(b)	BS805PN	316 ss	-SP, -HP, -PP, -PT, -TF, -NL, -EV, -AB, -PN, -PX
4 in ^(b)	BS805XS	316 ss	-RE, -LB, -BW, -UT
DN 100 ^(c)	BS805JM	316 ss	-SP, -HP, -PP, -PT, -TF, -NL, -EV, -AB, -PN, -PX

*Flange pressure and temperature ratings are per Notes a, b, and c below:

(a) MSS-SP-51 Class 150LW

(b) ANSI Class 300

(c) DIN 2501, 10 bar

Installation Procedure

When installing a sensor with a flange, use one or more of the spacers so that the O-ring on the sensor seats within the flange inside diameter.

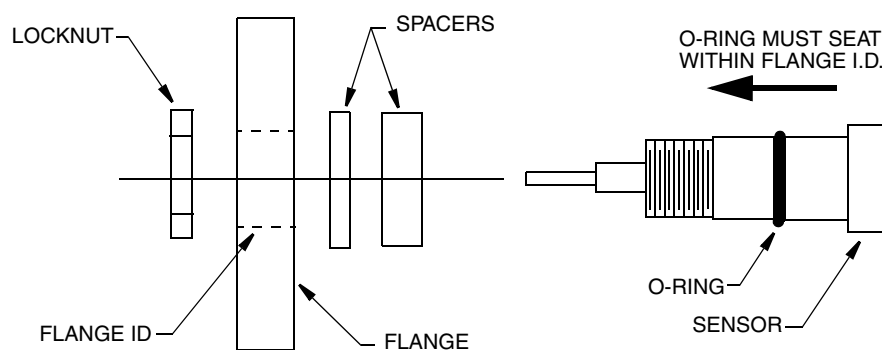

Figure 8. Typical Flange Installation

Bushing Installation (Sensor Types -TF, -SP, -NL, -HP, -PN, -PX, -PP, and -PT)

Bushings (locknuts supplied) are used for permanent installations in pipelines and tanks.

Bushing Specifications

Table 7. Hex Head Bushing Specifications

Material	Foxboro Part No.	Thread Size	Used with 871EC Sensor Body Codes	Rated Pressure at Specific Temperatures
316 ss	0051192	1-1/2 NPT	-TF, -NL, -SP, -HP, -PN, -PX, PP, PT	1.75 MPa (250 psi) @ 200°C (390°F)*
	BS805JJ	R 1-1/2 metric	-TF, -NL, -SP, -HP, -PN, -PX, PP, PT	
	0051193	2 NPT	-TF, -NL, -SP, -HP, -PN, -PX, PP, PT	
	BS805JC	R2 metric	-TF, -NL, -SP, -HP, -PN, -PX, -PP, PT	
Carpenter 20Cb	0051177	1-1/2 NPT	-TF, -NL, -SP, -HP, -PN, -PX, PP, PT	1.75 MPa (250 psi) @ 200°C (390°F)*
	BS805JK	R 1-1/2 metric	-TF, -NL, -SP, -HP, -PN, -PX, PP, PT	
	0051178	2 NPT	-TF, -NL, -SP, -HP, -PN, -PX, PP, PT	
	BS805JD	R2 metric	-TF, -NL, -SP, -HP, -PN, -PX, -PP, PT	
Kynar	BS805JF	1-1/2 NPT	-TF, -NL, -SP, -HP, -PN, -PX, PP, PT	1.0 MPa (150 psi) @ 25°C (77°F) 0.4 MPa (60 psi) @ 80°C 180°F 0.2 MPa (30 psi) @ 120°C (250°F)*
	BS805JH	R 1-1/2 metric	-TF, -NL, -SP, -HP, -PN, -PX, PP, PT	
	BS805HZ	2 NPT	-TF, -NL, -SP, -HP, -PN, -PX, -PP, PT	
	BS805JB	R2 metric	-TF, -NL, -SP, -HP, -PN, -PX, -PP, PT	
Noryl	BS805JE	1-1/2 NPT	-TF, -NL, -SP, -HP, PP, PT	1.4 MPa (200 psi) @ 25°C (77°F) 0.7 MPa (60 psi) @ 80°C (180°F) 0.3 MPa (50 psi) @ 95°C (200°F)*
	BS805JG	R 1-1/2 metric	-TF, -NL, -SP, -HP, -PN, -PX, PP, PT	
	BS805HY	2 NPT	-TF, -NL, -SP, -HP, -PN, -PX, -PP, PT	
	BS805JA	R2 metric	-TF, -NL, -SP, -HP, -PN, -PX, PP, PT	

*Maximum Temperature Rating

Installation Procedure

1. Feed the sensor cable through the bushing and locknut.
2. Wrap ptfе tape on the bushing thread. Screw the bushing into the pipe or tank and tighten as required.
3. Screw the locknut onto the sensor thread.

— NOTE —

If the cable end of the sensor will be exposed to moisture (for example, rain, hosing, or condensation), it should be further protected. Refer to “In Situ Installation” on page 25 section and perform Steps 1 through 9, except replace support pipe with appropriate electrical conduit.

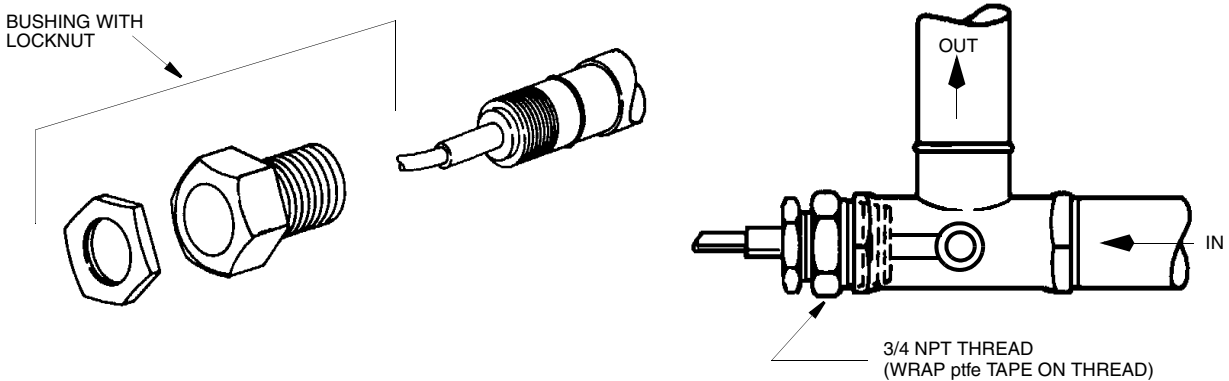
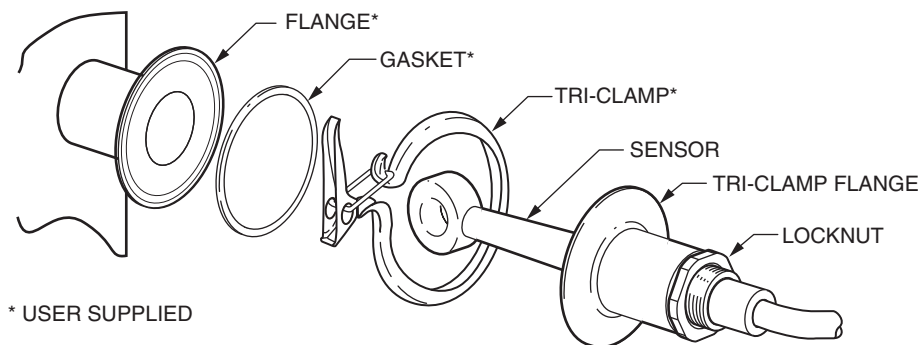

Figure 9. Typical Bushing Installations

Tri-Clamp Flange Installation

Install the sensor to a 2 in Tri-Clamp flange (see Figure 10). The flange on the process tank, the gasket, and the clamp are supplied by the user.



NOTE: -SP, -HP, -PP, AND -PT TYPE SENSOR IS SHOWN. -TF SENSOR HAS AN INTEGRAL FLANGE; THEREFORE NO SEPERATE TRI-CLAMP FLANGE OR LOCKNUT IS REQUIRED.

Figure 10. Tri-Clamp Flange Installation

In Situ Installation

If the sensor is supported by a length of DN 20 or 3/4-in pipe in a tank or stream, the sensor cable should be protected from damage by using flexible metal conduit.

— NOTE —

1. The end of the support pipe that is opposite the sensor must be above the process solution (enough to prevent the process solution from entering into that end of the pipe).
2. All Invensys Foxboro electrodeless sensors have an integral RTV seal at the cable end that protects the sensor against normal exterior moisture. Note that RTV is caustic sensitive.

! CAUTION

To avoid damaging the sensor cable jacket, use care when you remove the rubber strain relief.

1. Cut (as close to the end of the sensor as possible) and remove the rubber strain relief. See Figure 11(a).
2. Wrap several thicknesses of ptfе tape on the sensor threads. See Figure 11.

! CAUTION

Do not damage the cable when installing the coupling.

3. Slide the 3/4 NPT coupling (user supplied) over the sensor cable and thread coupling onto sensor threads.

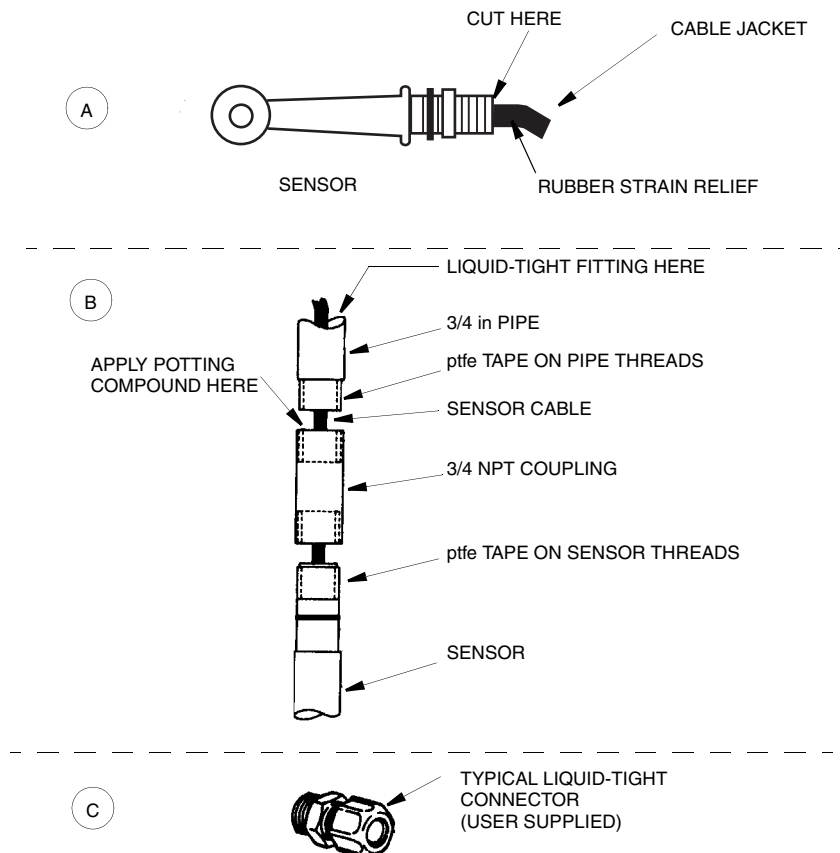

Figure 11. Typical In Situ Installation

4. Prepare a potting compound (for example, polyurethane). Follow manufacturer's instructions.
5. Pour potting compound into the top of the coupling. Fill to slightly below the top threads of the coupling.

— NOTE

A DN 20 or 3/4-in pipe (user supplied) should be used to support the sensor and coupling.

6. Wrap ptfе tape on the pipe threads.
7. Slide the pipe over the sensor cable and thread the pipe to the 3/4 NPT coupling.
8. Install liquid-tight connector (user supplied) into the top of the pipe. See Figure 11(c).
9. Slide flexible conduit (user supplied) over the remainder of the cable up to the liquid-tight connector.

In-Line Installation

For in-line applications within a metal or plastic pipe (see Figure 12), the pipe must have a minimum inside diameter, as shown in Table 8, and the sensor should be aligned as closely as possible with the centerline of the pipe.

Table 8. Minimum Pipe Diameters

Sensor Body Code	Minimum Pipe Diameter
-HP	76 mm (3 in)
-NL	76 mm (3 in)
-SP	76 mm (3 in)
-TF	76 mm (3 in)
-PP	76 mm (3 in)
-PT	76 mm (3 in)
-AB	230 mm (9 in)
-BW	152 mm (6 in)
-EV	230 mm (9 in)
-LB	152 mm (6 in)
-RE	152 mm (6 in)
-UT	152 mm (6 in)
-PN	76 mm (3 in)
-PX	76 mm (3 in)
EP307G	76 mm (3 in)

A larger pipe diameter should be used wherever possible to avoid distorting the measurement signal.

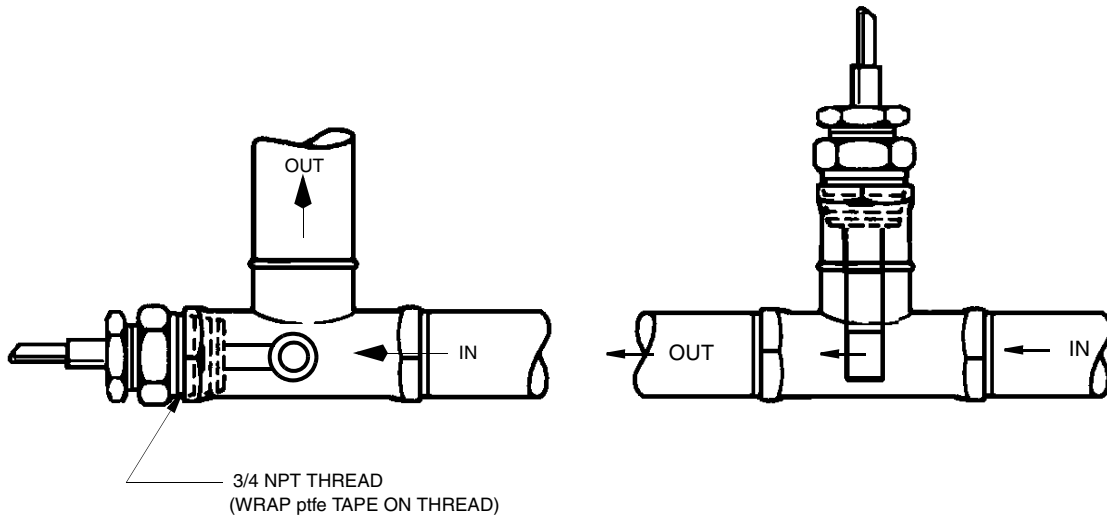

Figure 12. Typical In-Line Installation

Junction Box Installation

Mounting

The junction box is used when the distance between sensor and analyzer or transmitter is greater than the standard length of the sensor cable.

NOTE

The maximum recommended distance between the sensor and its analyzer or transmitter is 30 m (100 ft).

CAUTION

Cable length must be considered so that connections can be made without exposing cable to damage.

1. Select a rigid surface and a position protected from damage or exposure to excessive moisture and corrosive fumes.
2. Position the junction box against the mounting surface and mark the location of the mounting holes.
3. Drill the mounting holes on the marked centers.
4. Mount the junction box with appropriate hardware (user supplied).

Wiring

1. Remove the junction box cover and loosen the cable connectors (see Figure 13).
2. Insert the sensor cable through the appropriate connector and connect the numbered terminals of the sensor cable to the corresponding numbered terminals on the terminal strip.

3. Insert extension cable assembly through appropriate connector and connect the numbered terminals of extension cable assembly opposite the corresponding number.

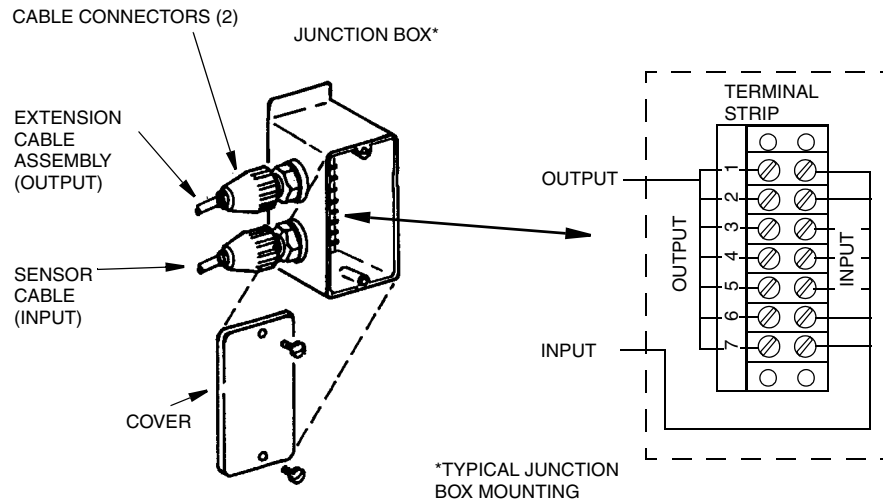

Figure 13. Junction Box Wiring

3. Maintenance

Troubleshooting

The following table identifies some faulty symptoms, possible causes, and corrective actions.

Table 9. Troubleshooting

Symptom	Possible Cause(s)	Corrective Action
Noisy or Erratic Measurement Signal	<ol style="list-style-type: none"> 1. Sensor is located near a pump, compressor, transmitting device (e.g., walkie talkie), etc. 2. Poor wire splice in sensor line 3. Excessively high flow rate 	<ol style="list-style-type: none"> 1. Relocate the sensor or the interfering device. 2. Check wire splices and repair as necessary. 3. Avoid exceeding the recommended maximum of 3.05 m/s (10 ft/s).
Low Measurement Signal	<ol style="list-style-type: none"> 1. Sensor is mounted in a pipe that is too narrow; causing a “sidewall” effect 2. Sensor has become magnetized (this can occur when the sensor is placed in a strong magnetic field from sources such as electric motors, etc.) 3. Sensors are located too close to each other 	<ol style="list-style-type: none"> 1. Make certain that the pipe diameter meets the minimum specification specified in Table 8 on page 27. 2. Degauss the sensor per the instructions that follow. 3. Avoid locating sensors within 460 mm (18 in) of each other.
Inaccurate or no Measurement Readings	<ol style="list-style-type: none"> 1. Sensor has been incorrectly calibrated 2. Use of excessive lengths of sensor cables 3. Defective sensor 	<ol style="list-style-type: none"> 1. Recalibrate the loop. When calibrating, note the precautions listed in “Installation Precautions” on page 15. 2. Maximum recommended overall cable length is 30.5 m (100 ft). 3. Check the sensor resistance values per “Sensor Resistance Check” on page 32. If defective, replace the sensor.
Drifting Measurement Readings	<ol style="list-style-type: none"> 1. Sensor incompletely submersed 2. Bubbles on sensor 	<ol style="list-style-type: none"> 1. Completely immerse sensor toroid head. 2. Avoid air/bubbles.
Zero Shift	Sensor is magnetized.	Degauss the sensor (see TI 612-005).

Checking for Sensor Magnetization

The sensor is susceptible to magnetization when located too close to sources of strong magnetic fields (such as electric motors). The following procedure can be used to determine if the sensor has become magnetized. A 1 M Ω resistance decade box is required.

1. Adjust the resistance decade box to 1 M Ω
2. With the sensor connected to the analyzer/transmitter, loop a wire through the sensor bore as shown in Figure 14. Connect the ends of the wire to the decade box and turn on the analyzer/transmitter (if not already on).
3. Slowly decrease the decade box resistance in small increments.
 - a. If the reading gradually increases as the resistance decreases, the sensor is **not** magnetized.
 - b. If the reading first decreases (or becomes negative), then increases (or becomes positive) the sensor is magnetized.
4. If the sensor is magnetized, degauss the sensor. Refer to TI 612-005.

— NOTE —

All Invensys Foxboro electrodeless sensors are routinely degaussed prior to shipment.

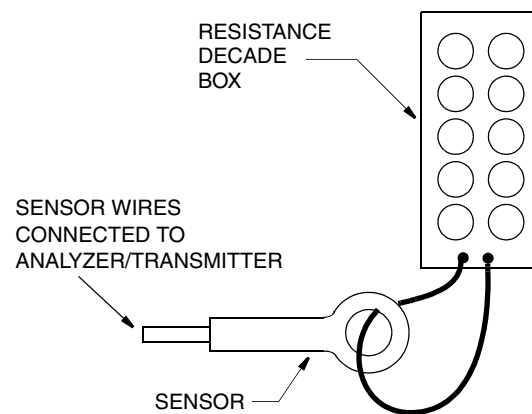

Figure 14. Sensor Magnetization Check

Sensor Resistance Check

To check sensor resistances, refer to the table in Figure 15

— NOTE —

Use a high impedance meter when making these checks because a low impedance meter can cause the probe to become magnetized.

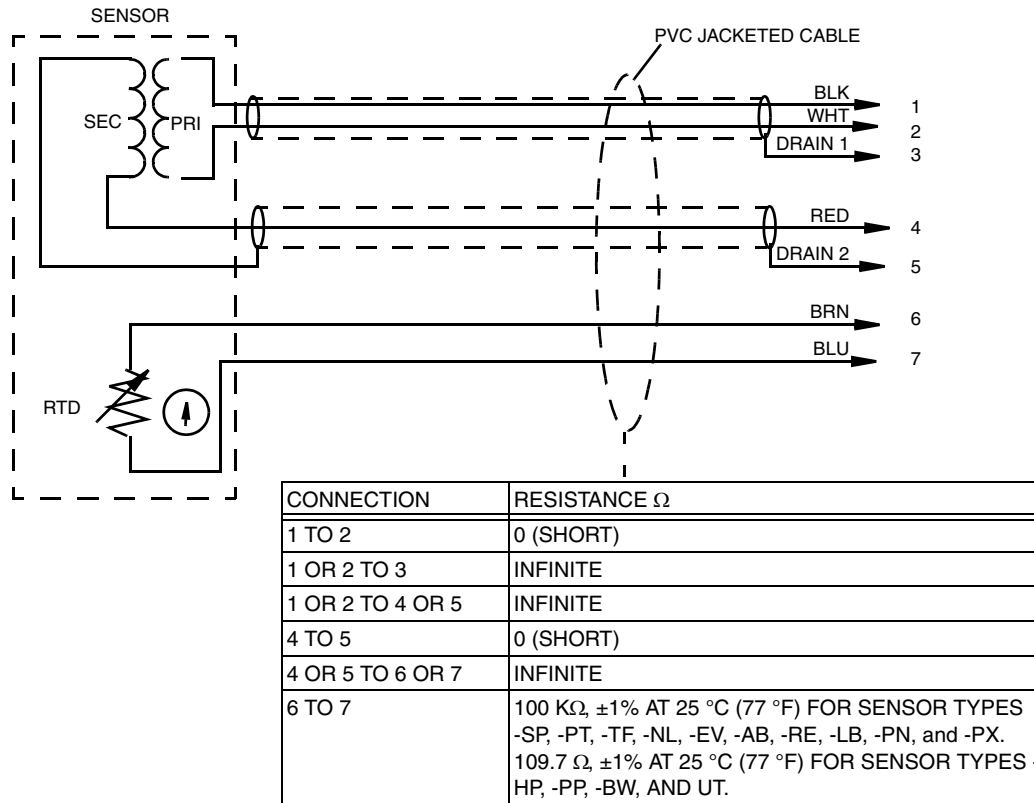

Figure 15. Sensor Cable Resistances

Appendix A. Temperature Compensation and Conductivity Reference Data

This matrix identifies (a) the standard curves resident in memory in an 875EC Intelligent Analyzer and/or an 870ITEC Intelligent Transmitter; (b) the temperature compensation range and the reference temperature of each standard curve; and (c) various typical conductivity values for low, mid, and high end percent concentrations at reference temperature, relative to the standard curve solutions.

Table 10. Approximate Conductivity Values of Common Solutions

Standard Curves(b)	Typical Conductivity Values at Reference Temperature and at Various Percent Concentrations Values Listed in this Table are in mS/cm(a) and are Approximations														
	1%	5%	10%	15%	18%	20%	25%	35%	42%	93%	96%	99.50%	99.90%	99.99%	
NaCl (25°C) 0 to 25%	20	80	140	188	212	225	248								
H ₃ PO ₄ (25°C) 0 to 35%	10	32	64	92	112	123	153	208							
HCl (25°C) 0 to 15%	112	430	700	820											
H ₂ SO ₄ (25°C) 0 to 25%	50	221	440	595	670	721	790								
H ₂ SO ₄ (50°C) 99.5 to 93%										230	205	63	46	42	
H ₂ SO ₄ (30°C) 96 to 93%										158	130				
Oleum (65°C) 42 to 18%					76	74	64	34	15						
Oleum (65°C) 0 to 10%	39	67	79												
HNO ₃ (25°C) 0 to 10%	63	281	500												
NaOH (25°C) 0 to 15%	60	220	355	410											
NaOH (50°C) 0 to 15%	76	320	530	650											
NaOH (100°C) 0 to 20%	100	495	850	1110	1230	1310									
KOH (25°C) 0 to 6%	38.5	178													
KCl (20°C) 0 to 16%	15.7	71.9	143	208											
CH ₃ COOH (25°C) 0 to 8%	0.64	1.43													
HF (25°C) 0 to 30%	11.7	59	120.5	189.5	236	260	325								

TABLE CONTINUES ON NEXT PAGE.

Table 10. Approximate Conductivity Values of Common Solutions (Continued)

Standard Curves(b)	Typical Conductivity Values at Reference Temperature and at Various Percent Concentrations Values Listed in this Table are in mS/cm(a) and are Approximations													
	1%	5%	10%	15%	18%	20%	25%	35%	42%	93%	96%	99.50%	99.90%	99.99%
HF (0°C) 90 to 99.9%											224	39.9	12.6	2.089
Na ₂ CO ₃ (85°C) Green Liquor	Typically some combination of sodium hydroxide, sodium carbonate, and sodium sulfite; 1000 mS/cm most commonly used for Full Scale Range.													
Na ₂ O (160°C) Black Liquor	Can be, for example, some combination of the following: sodium hydroxide and sodium carbonate, and could include sodium thiosulfate, sodium sulfide, and sodium sulfate; 1000 mS/cm typically used for Full Scale Range.													

- (a) The conductivity values listed have been taken from data published by numerous sources and are to be considered estimations only. Therefore, this table is provided for reference only, and precise conductivity values should be determined independently.
- (b) The standard curves listed are resident in the following transmitter and analyzer memories:
- 870ITEC Intelligent Electrochemical Transmitter
 - 875EC Intelligent Electrochemical Analyzer.

Index

A

Accessories 15

Applications 9

B

Ball Valve Assembly Installation 18

Bushing Installation 24

C

Cell Factors 12

Conductivity Reference Data 35

E

Electrical Safety Specifications 3

F

Flange Installation 22

I

Identification 6

In Situ Installation 25

In-Line Installation 27

Installation 15

 Ball Valve Assembly 18

 Bushing 24

 Flange (All sensor Types) 22

 In Situ 25

 In-Line 27

 Junction Box 28

 Tri-Clamp 25

J

Junction Box Installation 28

M

Maintenance 31

O

O-Ring Seals 17

P

Precautions, Installation 15

R

Reference Documents 2

Removal of Ball Valve Shaft and Sensor 21

S

Sensor Magnetization, Checking for 32

Sensor Resistance Check 32

Specifications 6

T

Temperature Compensation Data 35

Tri-Clamp Installation 25

Troubleshooting 31

ISSUE DATES

OCT 1985
JUN 1990
MAY 1995
MAR 1997
SEP 2001
MAR 2005
MAR 2006

Vertical lines to right of text or illustrations indicate areas changed at last issue date.

33 Commercial Street
Foxboro, MA 02035-2099
United States of America

<http://www.foxboro.com>
Inside U.S.: 1-866-746-6477
Outside U.S. 1-508-549-2424 or
contact your local Foxboro
Representative.
Facsimile: (508) 549-4492

Invensys and Foxboro are trademarks of Invensys plc, its subsidiaries, and affiliates.
All other brand names may be trademarks of their respective owners.

Copyright 1985-2006 Invensys Systems, Inc.
All rights reserved

MB 123

Printed in U.S.A.

0306