



AUTHORISED
EXPORTER
N° IT/004/BI/15

italvalvole® s.a.s.
di SPADON OSCAR & C.

Guide to the selection, use and maintenance of the FFF/10/REG control valves

CODE	14697
CATEG.	2761
GROUP	900
REVISION	02
DATE	18/07/2016

FFF/10/REG SERIES CONTROL VALVES FAMILY 04 GROUPS 150#151

Master handbook description: Guide to the selection, use and maintenance
of the FFF series control valves (English)

Code: 14697

Category: 2761

Group: 900

Revision no. : 02

Date: 18/07/2016

Drawn up by: MBL

Checked by: MB

Approved by: OS



IT AEOF 15 0974



ISO 9001 - Cert. n° 0302



Cert. PED N° 002-97/23/CE-D
Cert. PED N° PA001-97/23/CE-B

DIRECTIVE 2014/34/EU
CERTIFICATE N° 0425 ATEX 2519
CERTIFICATE N° 0425 ATEX 1318



DICHIARAZIONE DI CONFORMITA' UE

DECLARATION OF UE CONFORMITY

Mod: 710
Rev: 00
Data: 05/07/2016

VALVOLE DI REGOLAZIONE SERIE FFF/10/REG MODULATING VALVES SERIES FFF/10/REG

(in tutte le sue configurazioni / in all their configurations)

ITALVALVOLE® s.a.s. di Spadon Oscar & C. dichiara che l'intera gamma dei prodotti è stata progettata e costruita in accordo a quanto indicato nell'ALLEGATO I della direttiva UE:

ITALVALVOLE® s.a.s. of Spadon Oscar & C. declare that all products it was engineered and built in according as indicated on Annex 1 of the directive UE:

2014/68/UE

CLASSIFICAZIONE DELLE VALVOLE / CLASSIFICATION OF THE VALVES

CATEGORIA I per fluidi del gruppo **II** - **CATEGORY I** for fluids group **II**

Secondo valutazione di conformità descritte dall' allegato III (MODULO A)
With respect to the conformity described in annex III (MODULE A)

NORME TECNICHE ARMONIZZATE e SPECIFICHE UTILIZZATE:
HARMONISED TECHNICAL STANDARDS and SPECIFICATIONS USED:

UNI EN 12266-1-2 / UNI EN 10213

ALTRE DIRETTIVE EUROPEE APPLICATE:
OTHER EUROPEAN STANDARDS APPLIED:

2014/34/UE

Marcatura dell'apparecchiatura:
Marking of equipments:

CE Ex II 2 G D c Tx X

Certificato numero:
Certification No:

0425 ATEX 2519

ENTE NOTIFICATO – NOTIFIED BODY

ICIM S.p.a

Via Don Enrico Mapelli, 75 – 20099 Sesto San Giovanni (MI)

Numero Identificativo dell'Organismo Notificato
Notified Body Identification Number:

0425

LUOGO e DATA - Place and Date
Cossato, 19/07/2016

Legale rappresentante
Legal representative

Table of contents

1	Foreword	5
2	Legend	5
3	Inquiries	6
4	Technical features	6
	Table 1: Compatible Fluids	7
4.1	Table 2: Δp of FFF/10/REG control valves	8
4.2	Safety Notes	8
4.3	Overall dimensions of FFF/10/REG control valves	9
4.3.1	FFF/10/REG control valve	9
5	Storage, Assembly, Check And Maintenance	10
5.1	Transport, Storage And Handling	10
5.2	Assembly Instructions	10
5.2.1	General information	10
5.2.2	Installation of the valve on the plant	10
5.3	Installation diagram	11
5.3.1	FFF/10 control valve installation	11
5.4	Operation Test	11
5.5	Troubleshooting	12
5.5.1	Fluid passage with valve closed	12
5.5.2	Diaphragm (membrane)	12
5.6	Scheduled Maintenance	12
5.7	Instructions for the disassembly and assembly of the FFF/10/REG DN 15#65 control valve	13
5.7.1	Removal of the normally closed servo control from the valve	13
5.7.2	Removal of the normally open servo control from the valve	13
5.7.3	Positioning the normally closed servo control on the valve	13
5.7.4	Positioning the normally open servo control on the valve	13
5.8	Disassembly and assembly instructions for the FFF/10/REG NC control valve servo control	15
5.8.1	Disassembly	15
5.8.2	Reassembly	15
5.9	Disassembly and assembly instructions for the FFF/10/REG NO control valve servo control	17
5.9.1	Disassembly	17
5.9.2	Reassembly	17
5.10	Instructions for the disassembly, the gasket replacement and the reassembly of the FFF/10/REG DN 15#50 control valve bodies	19
5.10.1	Disassembly	19
5.10.2	Reassembly	19
5.11	Instructions for the disassembly, the gasket replacement and the reassembly of the FFF/10/REG DN 65 control valve bodies	21
5.11.1	Disassembly	21
5.11.2	Reassembly	21
5.12	Components and spare parts of the FFF/10/REG DN 15#50 NC./NO. control valve	23
5.13	Components and spare parts of the FFF/10/REG DN 65 NC./NO. control valve	24
6	Table 3: Servo control springs	25

7	Table 4: Tightening Torques	25
8	Valve life.....	25
9	Disposal	25
10	Warranty.....	26

1 Foreword

The continuous research and innovation process has led us to develop the FFF series regulating valves: free flow valves (body at 45°), extremely compact and controlled by a modulating servo control.

They are available with threaded or socket welding connections and with heads made of painted steel or of stainless steel.

Their field of use is fluid control (liquids, gas, steam) through the regulation of the physical variables (pressure, temperature, flow rate) within a process.

Valves with diaphragm servo control have been conceived to check the flow of overheated water, liquids, gas and steam in pipes.

FFF/10/REG-series control valves are the basic element of flow rate control (as a consequence, of temperature and pressure control) for a fluid, within the process in an automatic plant.



Control valves, FFF/10/REG series

- **The stroke indicator, microcast in AISI 304, replaces the pressed washer and indication arrow provides clearer and immediate reading of valve stroke.**
- **Valves may be equipped with a with stainless steel head servo control, to be used in the presence of aggressive atmospheres.**

Opening, closing and modulating action of valve are generated by the variation of pneumatic signal reaching the servocontrol (valve pneumatic head).

Diaphragm/spring combinations delivered inside valve pneumatic head cover the following inlet signal ranges on diaphragm: 3/15 psi (0.2/1.0 bar), 6/18 psi (0.42/1.26 bar), 6/30 psi (0.42/2.1 bar), 9/32 psi (0.6/2.24 bar).

The ITALVALVOLE® control valves of FFF/10/REG series are supplied as normally closed N.C. (air opens), or as normally open N.O. (aria closes).

Anyway, since servo control is reversible, it can transform a N.C. valve into N.O. valve or vice versa by simply replacing a few details.

2 Legend

- $\Delta p_{\text{allowed}}$ (allowed differential pressure): pressure whose algebraic value corresponds to the difference in pressure between the two sides of a partition panel (UNI EN 764-1:2005) at a given temperature and with the valve closed.
- **Maximum/minimum allowed temperature:** minimum/maximum temperature for which the equipment has been designed, as specified by the manufacturer (UNI EN 764-1:2005).
- **Maximum allowed pressure:** maximum pressure for which the equipment has been designed, as specified by the manufacturer (UNI EN 764-1:2005).
- **DN:** it is an alphanumeric designation of size for components of a pipework system, which is used for reference purposes.
It comprises the letters DN followed by a dimensionless whole number which is indirectly related to the physical dimension, expressed in millimetres, of the hole or of the outer diameter of the ends of connection pipes (ISO 6708:1997).
- **Kv:** flow rate, expressed in m³/h, of water (10 to 25 °C with a volume equal to 1000 Kg/m³) flowing through two ways of a valve, with a pressure drop Δp of 100 KPa (1 bar)

$$Kv = \frac{Q}{\sqrt{\Delta p}}$$

where: Q is the flow rate in m³/h.

3 Inquiries

In case of specific needs or doubts, please contact our technical office after filling in the form below and the suitable type of valve to be used will be communicated to you.

DATA REQUIRED:

DN _____ PN 16

Control signal _____

Shutter linear; equipercentage; disc;

Body material CF8M stainless steel; brass; bronze;

Valve action normally closed

normally open

Operating fluid _____ Specific weight _____ Kg/m³

Maximum flow rate _____ Kg/h _____ m³/h

Pressure upstream the valve _____ bars

Pressure downstream the valve _____ bars

Fluid temperature in °C _____

With handwheel With pneumatic positioning device

4 Technical features

- General remark:** ⇒ All the pressure values indicated hereinafter are relative pressure values
 ⇒ **Valve designed for group 2 fluids (2014/68/UE directive). For the use with fluids of group 1 (directive 2014/68/UE), please contact our Engineering office.**
- DN:** ⇒ 15 # 65
- PN:** ⇒ 16
- Connections:** ⇒ Threaded, female, GAS
 Socket welding
- Pmax all.:** ⇒ 16 bar
- Pmin all.:** ⇒ 0 bar
- Seal:** ⇒ PTFE, EPDM, PTFE-coated EPDM
- Shutter charact.:** ⇒ Equipercentage, linear, disc
- Shutter stroke:** ⇒ 15mm (20 mm upon request)
- Body material:** ⇒ ASTM A351 CF8M (EN 10213-4 1.4408), brass, bronze
- Tmax all.:** ⇒ +200°C with PTFE seal
 +150 °C with EPDM seal
 +155 °C with PTFE-coated EPDM seal
- Tmin all.:** ⇒ -10 °C (in liquid phase)
- Flow direction:** ⇒ 2-way globe valve, with angle body, oblique unidirectional.
- Air connection:** ⇒ Quick joint RILSAN Ø 6-4 mm.
- Supply fluid:** ⇒ Instrument air
- Supply pipes:** ⇒ pipe inner diameter = 4 mm, min. outdoor diameter = 6 mm
- Supply P (supply):** ⇒ 3÷15 PSI, 6÷18 PSI, 6÷30 PSI, 9÷32 PSI,
- Versions:** ⇒ Normally closed, normally open, with emergency handwheel, with positioning devices, with electric positioning devices, transducers, FRM units (filter, reducer, gauge).
- Manufacturing materials:** ⇒ See drawings and relevant tables
- Dimensions:** ⇒ See overall dimension drawings and relevant tables

Table 1: Compatible Fluids

FLUID	SEAL TYPE			FLUID	SEAL TYPE		
	EPDM	PTFE	EPDM coated with PTFE		EPDM	PTFE	EPDM coated with PTFE
Vinyl acetate	A	A	A	Sodium chloride 20% max	A	A	A
Phenol acetylene	B	A	B	Potassium chloride 5% max	A	A	A
Glycerol fat acids	A	A	A	Butyl ether	C	A	C
Phenol	B	A	B	Petroleum ether	D	A	D
Phosphoric acid 20% max.	A	A	A	Dibenzile ether	B	A	B
Phthalic acid	A	A	A	Dibutyl ether	C	A	C
Gallic acid	B	A	B	Ethylene glycol	A	A	A
Nitric acid 5% - 65% max	C	A	C	Ammonium nitrate	A	A	A
Oleic acid	C	A	C	Copper nitrate	A	A	A
Stearic acid	B	A	B	Sodium nitrate	A	A	A
Tannic acid	A	A	A	Ethylene perchlorate	D	A	D
Butanol	B	A	B	Potassium sulphate 20% max at T=100 °C	A	A	A
Ethanol	A	A	A	Sodium sulphate	A	A	A
Methanol	A	A	A	Zinc sulphate 40% max at T=100 °C	A	A	A
Propanol	A	A	A	Potassium sulphite 10% max	A	A	A
Aniline	B	A	B	Sodium sulphide	A	A	A
Sodium carbonate 20% max	A	A	A	Toluene	D	A	D
Borax (sodium tetraborate)	A	A	A	Water Steam T _{max} =130 °C P=2.7 bar	A	A	A
Sodium carbonate	A	A	A	Water Steam T _{max} =170 °C P=8 bar	C	A	A
Potassium chlorate 30% max	A	A	A				

Table legend: **A** good resistance (weak or no attack)
 B conditioned resistance (medium attack)
 C no resistance (strong attack)
 D decomposition (swelling and decay)

All data in table 1, if not otherwise specified, is relevant at a temperature of 21°C.

All data have a general meaning and are not valid for all possible working conditions. These data may considerably vary depending upon various conditions, such as: temperature, concentration, fluid speed.

For detailed information, please get in touch with the technical department.

Any use of the valve on explosive, easily inflammable, comburent and poison gases is strictly forbidden.

Any use of the valve on liquids based on: chlorine, fluorine, bromine, iodine and derivative elements is strictly forbidden.

Any deviation from such prohibitions may be issued for special applications, by our technical department, upon written request.

4.1 Table 2: Δp of FFF/10/REG control valves

					Δp Valve				
Control signal in PSI ⁽¹⁾					3/15	6/18	6/30	9/32	
Control signal in BAR					0,2/1	0,42/1,26	0,4/2,1	0,6/2,24	
Max control pressure BAR					1,2	1,4	2,2	2,4	
DN	ϕ seat [mm]	Stroke [mm]	Kvs	CV	ϕ e servo c. [mm]	Letters for valve definition			
			Equipercantage shutter	Equipercantage shutter		A	B	C	D
15	15	15	4,5	5,2	200	10,5	16	16	16
					275	16	16	16	16
20	20	15	8,5	9,9	200	7	14	16	16
					275	18	36	16	16
					360	40	40	16	16
25	25	15	11,3	13,1	200	4,5	9	9	13,5
					275	11	16	16	16
					360	16	16	16	16
32	32	15	18,9	22	200	2,7	5,4	5,4	8,1
					275	6,8	13,6	13,6	16
					360	13,6	16	16	16
					430	16	16	16	16
40	40	15	22,3	25,9	200	1,7	3,4	3,4	5,1
					275	4,2	8,4	8,4	12,6
					360	8,2	16	16	16
					430	8,6	16	16	16
50	50	15	43,4	50,3	200	1,1	2,2	2,2	3,3
					275	2,7	5,5	5,5	8,3
					360	5,5	11	11	16
					430	5,6	11,2	11,2	16
65	65	15	61,8	71,7	200	0,7	1,3	1,3	2
					275	1,7	3,3	3,3	5
					360	3,3	6,6	6,6	10
					430	3,4	6,8	6,8	10,2

Note: Δp Max symbol has been obtained with no air in head.

(1) In NO valves, to obtain the same Δp as NC valves, the maximum control signal must consist of the addition of two signals; for example, in a NO valve with 3/15 PSI signal, the maximum control signal must be taken to 18 PSI (3+15) to obtain Δp of similar NC valve.

The Kv has been calculated using the FLOWSimulation fluid dynamics program in accordance with the UNI EN 1267:2001 standard

4.2 Safety Notes

- The valve body, under maximum operating temperature conditions, depending on the system, may reach a $T=200^{\circ}\text{C}$. It is up to the engineer to provide the system with the necessary safety guards and/or warning signals, to remove/signal the risk of possible burns to the user.
- During any operation on the valve, the fluid shall not be present inside the piping or the valve.

4.3 Overall dimensions of FFF/10/REG control valves

4.3.1 FFF/10/REG control valve

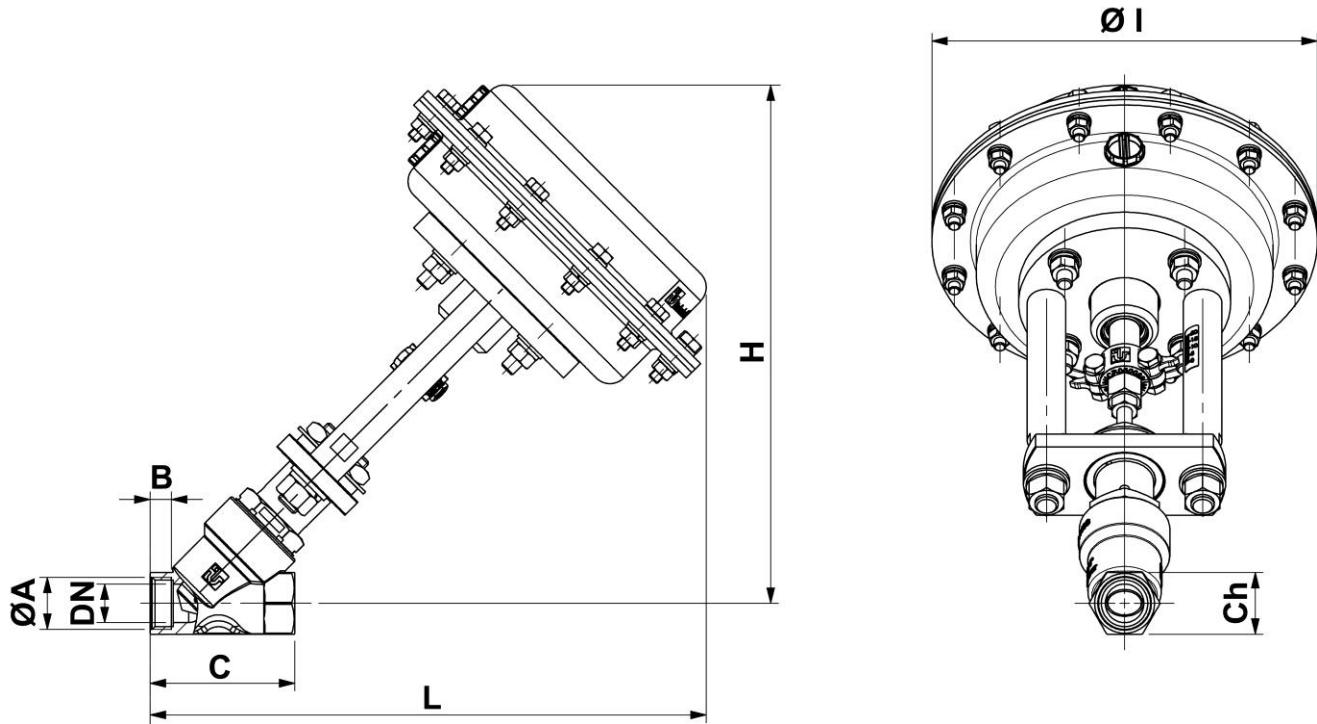

DN	Ø A		B		C	Ø I	L				H				Ch
	Threaded	Socket welding	Threaded	Socket welding			200	275	360	430	200	275	360	430	
15	1/2"	22	8	11	65	According to the sealing Δp (200-275-360-430)	285	316,5	/	/	267	298,5	/	/	27
20	3/4"	27,5	9	12	75		288,5	320	347,5	/	268,5	300	327,5	/	32
25	1"	34	12	15	90		302,5	334	361,5	/	276	307,5	335	/	39
32	1"1/4	43	14	17	110		324	355,5	383	420	289	320,5	348	385	49
40	1"1/2	49	14	17	120		328	359,5	387	424	294	325,5	353	390	55
50	2"	61	16	19	150		343	374,5	402	439	305	336,5	364	401	68
65	2"1/2	77	26	28	185		413	444	474	510	361	395	423	460	88

5 Storage, Assembly, Check And Maintenance

5.1 Transport, Storage And Handling

During transport and assembly the FFF/10/REG control valves must be handled with utmost care. Shocks as well as anomalous stresses must be avoided (do not lift the valve by servo control).

Avoid shocks and tampering to any accessories the valve may be equipped with (positioning devices, transducers, FRM units, etc.).

Valves are delivered with dust-proof protections on all connections and these protections must not be removed until they are installed.

Valves shall be stored in areas which are not exposed to the sunshine, so as to prevent inner gaskets and membrane from getting dry and old before time.

Storage temperature shall be between 0°C and + 50°C.

Avoid any shock to servo control as they could provoke misalignments and affect valve proper operation.

Comply with specifications on labels.

5.2 Assembly Instructions

5.2.1 General information

Valve installation on the system shall be carried out only by personnel qualified in hydraulics and pneumatics, provided with all the equipment normally used in the industrial hydraulic and pneumatic plant engineering. The personnel shall always wear proper accident prevention garments, taking particular care to protect face, eyes and hands.

The valve must never be disassembled or modified. Otherwise, warranty is voided.

N.B. Attention: Compressed springs are included inside the servo control.

Before assembly, dust-proof protections shall be removed from the valve body.

The threaded cap on unused air connection must not be removed to prevent dust or foreign matters from entering the servo control.

Compressed air shall be industrial air, with a pressure between servo control useful values and anyway never exceeding 2.5 bars, with supply pipes made of nylon or copper and $\text{inner } \varnothing = 4 \text{ mm}$. Air connections on valve must be 1/8" GAS (head \varnothing 200) or 1/4" (head \varnothing 275, \varnothing 360, 430) male threaded couplings.

5.2.2 Installation of the valve on the plant

Comply with specifications on labels and valve body fusion

Before assembly, ensure that no dirt has penetrate the valve body; in case of doubt, strongly blow with compressed air.

It is recommended to install a protection filter on pipe upstream the valve.

The commonest recommended installation provides for vertical assembly of the valve, with servo control on top. Tilted or horizontal assemblies are only accepted for dimensional reasons only.

To ensure a continuous operation of the plant also during valve maintenance, it is recommended to provide for a proper bypass with relevant on-off and manual control valves.

WARNINGS: when installing a valve, provide for a minimum space necessary to disassemble the pneumatic servo control and internal organs during maintenance operations.

N.B. Attention: Compressed springs are included inside the servo control.

Be very careful when assembling the pipe valve, ensure it is installed in compliance with specifications on body fusion, in the same direction as pipe flow.

It is recommended to use joints between plant pipes and valve connections, suitable to discharge any tensions possibly damaging the valve itself.

After installation, with pneumatic valve in maximum opening position, carefully clean the line with suitably pressurized fluid to remove any foreign bodies, welding slags and debris possibly damaging valve sealing surfaces.

Connect the pneumatic signal from the pilot regulator or from the remote control panel to the relevant coupling on the servo control.

5.3 Installation diagram

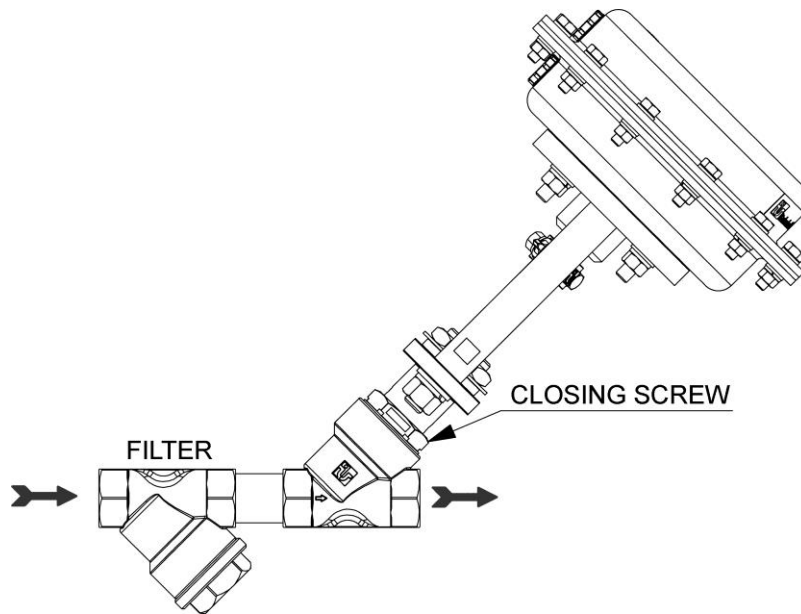

Figure 1

5.3.1 FFF/10 control valve installation

When installing the FFF/10/REG control valves, a filter must be assembled on valve inlet to collect any impurity that might damage the sealing. Assemble the FFF/10/REG control valve as shown in figure 1, following the direction arrows on the valve. After the first few hours of hot operation you need to check the tightness of the closing screw (remember to inject air into the N.C. valve and to remove air in the N.O. valve).

5.4 Operation Test

Before starting up the system and after any repair or overhaul, the following operation test shall be carried out:

On valves with normally closed NC servo control:

- 1) Send the fluid inside the valve under shutter at the operating pressure (check that it is always lower than the maximum allowable pressure of the valve as shown on specifications plate).
- 2) Insert into servo control the minimum value of control signal shown on specifications plate (the valve should start opening, datum available on stroke plate).
- 3) Insert into servo control the maximum value of control signal shown on specifications plate (the valve should be fully open, datum available on stroke plate).
- 4) Switch off air from the servo control.
- 5) Repeat this operation 5 times.
- 6) Check, with air off, that there is no leak from the valve.
- 7) Check, with air on, that there is no air leak from the servo control.

On valves with normally open NO servo control:

- 1) Send the fluid inside the valve under shutter at the operating pressure (check that it is always lower than the maximum allowable pressure of the valve).
- 2) Insert into servo control the minimum value of control signal shown on specifications plate (the valve should start closing, datum available on stroke plate).
- 3) Insert into servo control a pressure value equal to the sum of the two control signals shown on specifications plate (the valve should close; data can be found on the stroke plate).
- 4) Repeat this operation 5 times.
- 5) Check, with air on, that there is no leak from the valve (with pressure value equal to the addition of two signals $3/15 = 18$ PSI).
- 6) Check, with air on, that there is no air leak from the servo control.

5.5 Troubleshooting

Troubleshooting operations shall be always carried out by qualified personnel only, adequately equipped for the hydraulic and pneumatic operations and provided with the proper safety clothing, paying particular attention to the protection of face, eyes and hands.

Please note: to properly operate the valve, the stem must freely move with no friction when air pressure on diaphragm changes.

Valve serial number is printed on the label located on servo control. Please refer to the serial number for spare part request and correspondence.

Whenever operations are to be carried out on valves, remove the fluid completely. The valve body shall be completely empty.

5.5.1 Fluid passage with valve closed

If the valve is in closed position, ensure that no foreign body exist between shutter and seat; also check that contact surfaces are not damaged.

Should the shutter cap get damaged, in such a way as to affect the valve tightness, you will need to replace the shutter, while if tightness is affected by breaks on the machined part of the valve body you will need to replace the valve body (for information about valve disassembly see below).

5.5.2 Diaphragm (membrane)

If the rubber membrane inside the servo control breaks, the valve cannot perform a complete stroke.

Replace the membrane when it is broken or has lost elasticity (see proper procedure below).

In all cases of irregular operation during adjustment, immediately ensure that pneumatic connections between the pilot regulator, the valve and the relevant fittings show no signs of air leaks.

Also ensure that regulator is properly calibrated (activity direction, proportionate band, automatic restoration) and that it operates correctly.

5.6 Scheduled Maintenance

Scheduled maintenance operations shall be carried out independently of the ones due to possible failures, which always require an immediate intervention.

The time interval between one maintenance operation and the following shall be included in the lower time interval between the one corresponding to 500,000 cycles and three years; it consists of a complete disassembly of the valve, replacement of all the gaskets and a complete cleaning of all other components. For disassembly and re-assembly operations, make reference to the relevant paragraphs of this manual.

5.7 Instructions for the disassembly and assembly of the FFF/10/REG DN 15#65 control valve

For the disassembly and assembly operations of the servo control for all FFF/10/REG valves, refer to the annexed dwg. no. 100785

Assembly and disassembly operations shall be carried out only by personnel qualified in hydraulics and pneumatics, provided with all the necessary work and safety equipment. Before carrying out any operation on systems and valves, get acquainted with operating temperatures and pressures and any other particular conditions, and take the relevant safety measures.

Whenever operations are to be carried out on valves, remove the fluid completely.

NOTE: Thoroughly read the procedures before proceeding with operation.

5.7.1 Removal of the normally closed servo control from the valve

- 1) Enter an air signal into the servo control, equal to the maximum value provided for by the signal: **Warning! The servo control shaft will move upward**
- 2) Unscrew the nuts (36), extract the spring washers (35) and the screws (33), then separate the junction clamps (34).
- 3) Unscrew the nuts (43), remove the spring washers (42) and the plain washers (41), then withdraw the columns (37) from the lower flange (40), separating the valve into two parts.
- 4) Cut off the air supply to the servo control.
- 5) Unscrew the nuts (31), extract the spring washers (30) and the plain washers (29), then withdraw the servo control from the upper flange (28).

5.7.2 Removal of the normally open servo control from the valve

- 1) Unscrew the nuts (36), extract the spring washers (35) and the screws (33), then separate the junction clamps (34).
- 2) Unscrew the nuts (43), remove the spring washers (42) and the plain washers (41), then withdraw the columns (37) from the lower flange (40), separating the valve into two parts.
- 3) Unscrew the nuts (31), extract the spring washers (30) and the plain washers (29), then withdraw the servo control from the upper flange (28).

5.7.3 Positioning the normally closed servo control on the valve

- 1) Insert the servo control stud bolts into the special seats on the upper flange (28), orienting the air connection along the valve flow axis.
- 2) Insert the plain washers (29) and the spring washers (30) onto the stud bolts.
- 3) Tighten to the prescribed torque the nuts (31), as indicated in Table 4 at page 26.
- 4) Blow air in the servo control **Attention! The servo control shaft will move by its stroke.**
- 5) Insert the columns (37) into the special seats on the lower flange (40).
- 6) Insert onto the column threads (37) the plain washers (29) and the spring washers (30), then tighten to the prescribed torque the nuts (31), as indicated in table 4 at page 26.
- 7) Cut off the air supply to the servo control. **Warning! The servo control shaft will move by its stroke.**
- 8) Lock the servo control shaft (10) and the preload adjustment nut (11) with the junction clamps (34).
- 9) Insert into the junction clamps (34) the screws (33) and the spring washers (35).
- 10) Tighten to the prescribed torque the nuts (36), as indicated in Table 4 at page 26.

5.7.4 Positioning the normally open servo control on the valve

- 1) Insert the columns (37) into the special seats on the lower flange (40).
- 2) Insert onto the column threads (37) the plain washers (29) and the spring washers (30), then tighten to the prescribed torque the nuts (31), as indicated in table 4 at page 26.
- 3) Insert the servo control stud bolts into the special seats on the upper flange (28), orienting the air connection along the valve flow axis.
- 4) Insert the plain washers (29) and the spring washers (30) onto the stud bolts.
- 5) Tighten to the prescribed torque the nuts (31), as indicated in Table 4 at page 26.
- 6) Bring the preload adjustment nut (11) into contact with the servo control shaft (10), lifting the shutter (21).
- 7) Lock the servo control shaft (10) and the preload adjustment nut (11) with the junction clamps (34).
- 8) Insert into the junction clamps (34) the screws (33) and the spring washers (35).
- 9) Tighten to the prescribed torque the nuts (36), as indicated in Table 4 at page 26.

Sectional view of the FFF/10/REG DN 15#50 NC control valve

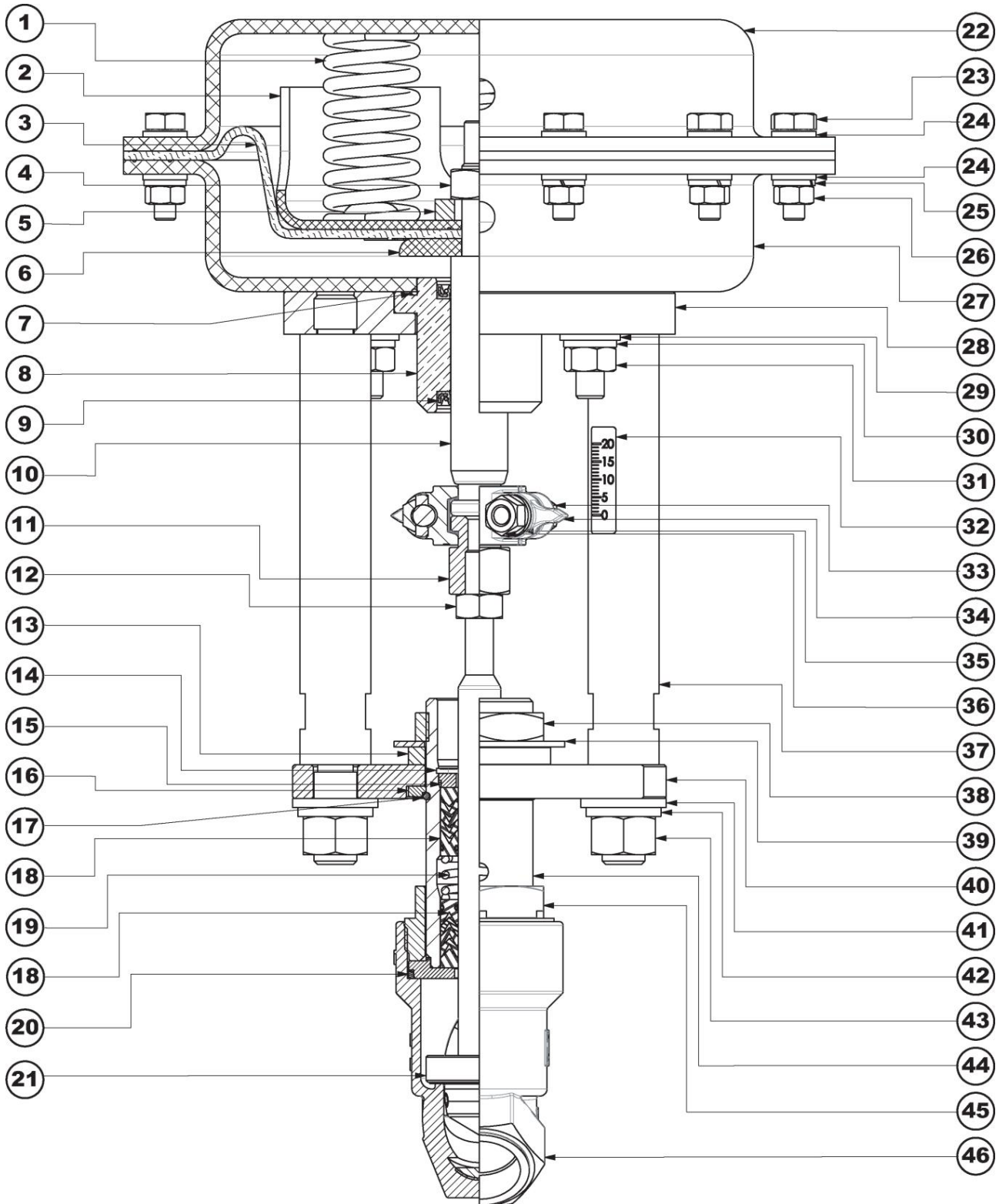

Drawing No. 100785 Rev.:00

5.8 Disassembly and assembly instructions for the FFF/10/REG NC control valve servo control

For the disassembly and assembly operations of the servo control for the FFF/10/REG N.C. control valve, refer to the annexed dwg. no. 100785 .

Assembly and disassembly operations shall be carried out only by personnel qualified in hydraulics and pneumatics, provided with all the necessary work and safety equipment. Before carrying out any operation on systems and valves, get acquainted with operating temperatures and pressures and any other particular conditions, and take the relevant safety measures.

Whenever operations are to be carried out on valves, remove the fluid completely.

NOTE: Thoroughly read the procedures before proceeding with operation.

5.8.1 Disassembly

- 1) Separate the servo control from the valve body as described in paragraph 5.7.
- 2) Extract jig bushing (8). Remove BA (9) and OR gasket (7) from it.
- 3) Untighten the screws (23) and separate them from the nuts (26), from the spring washers (25) and from the plain washers (24).
- 4) **Warning! Compressed springs are included inside the servo control:** use a suitable equipment to prevent sudden separation of two servo control heads when all screws are untightened (23).
- 5) Remove the upper head (22).
- 6) Extract servo control springs (1).
- 7) Extract the lower head (27) from servo control shaft (10).
- 8) Lock the servo control shaft between soft cheeks (10), then unscrew the hexagonal nut (4).
- 9) Extract the servo control shaft (10) from spacer ring washer(5), spring-holding plate (2), membrane (3) and diaphragm counter-disc (6).
- 10) Now the servo control has been completely disassembled, so that the required components can be replaced.

5.8.2 Reassembly

- 1) Fasten the servo control shaft (10) between soft jaws, insert on it diaphragm counter-disc (6), membrane (3), spring-holding plate (2) and spacer ring washer (5).
- 2) Tighten and punch hexagonal nut (4).
- 3) Insert the thus assembled servo control shaft (10) into the lower head (27).
- 4) Place membrane (3) so that its screw holes match the lower head screw holes (27).
- 5) Insert springs (1) into spring-holding plate (2), by placing them on centring bosses located on spring-holding plate.
- 6) Place upper head (22) so that air holes of both heads are on the same vertical line and screw holes correspond with membrane and lower head screw holes.
- 7) Using proper instruments, press the springs go get the two heads closer. **Warning! Ensure that two heads cannot suddenly separate before being fastened with proper screws.**
- 8) Insert into the screws (23) the plain washers (24), insert the screws (23) into the upper head holes (22), insert onto the screws (23) the plain washers (24) and the spring washers (25), tighten to the prescribed torque the hexagonal nuts (26), as indicated in Table 4 at page 26.
- 9) Insert BA (9) and OR gasket (7) into jig bushing (8).
- 10) Insert jig bushing assembled (8) on servo control shaft (10) and lower head (27).
- 11) Now, servo control is completely assembled and can be re-located on valve frame.

Sectional view of the FFF/10/REG DN 15#50 NC control valve

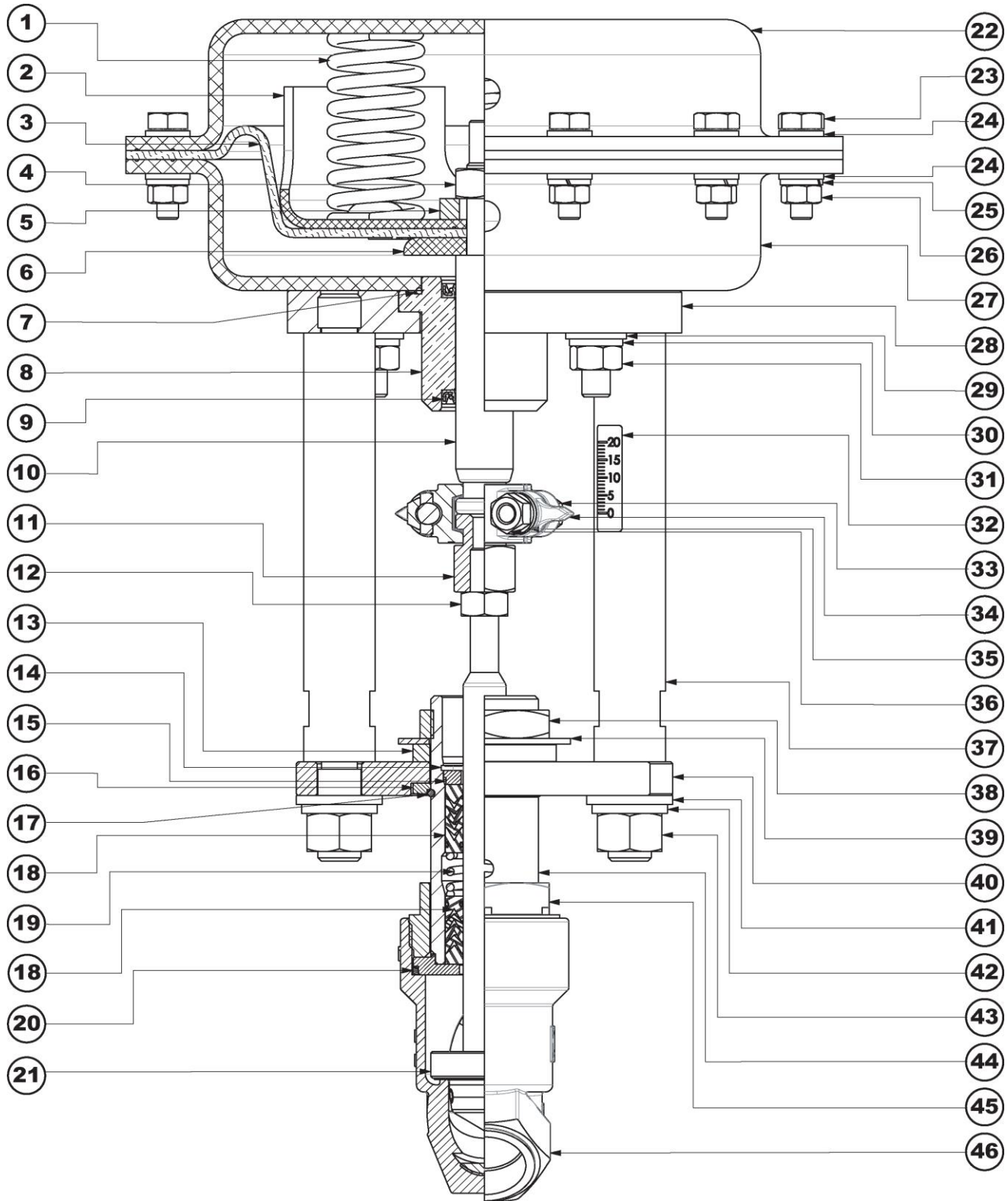

Drawing No. 100785 Rev.:00

5.9 Disassembly and assembly instructions for the FFF/10/REG NO control valve servo control

For the disassembly and assembly operations of the servo control for the FFF/10/REG N.O. control valve, refer to the annexed dwg. no. 120062 .

Assembly and disassembly operations shall be carried out only by personnel qualified in hydraulics and pneumatics, provided with all the necessary work and safety equipment. Before carrying out any operation on systems and valves, get acquainted with operating temperatures and pressures and any other particular conditions, and take the relevant safety measures.

Whenever operations are to be carried out on valves, remove the fluid completely.

NOTE: Thoroughly read the procedures before proceeding with operation.

5.9.1 Disassembly

- 1) Separate the servo control from the valve body as described in paragraph 5.7.
- 2) Extract jig bushing (8). Remove BA (9) and OR gasket (7) from it.
- 3) Untighten screws (23) and separate from nuts (26), from plain washers (24) and from spring washers (25).
- 4) **Warning! Compressed springs are included inside the servo control:** use a suitable equipment to prevent sudden separation of two servo control heads when all screws are untightened (23).
- 5) Remove the upper head (22).
- 6) Extract the lower head (27) from servo control shaft (10).
- 7) Extract the springs (1) from lower head (27).
- 8) Lock the servo control shaft (10) between soft jaws and unscrew the hexagonal nut (4), then extract the diaphragm counter-disc (6). Note: 200 diameter servo control has no nut (4), but the same diaphragm counterdisc works like a closing nut.
- 9) Extract membrane (3), spring-holding plate (2) and spacer (5) from servo control shaft (10).
- 10) Now the servo control has been completely disassembled, so that the required components can be replaced.

5.9.2 Reassembly

- 1) Fasten the servo control shaft (10) between soft jaws, insert on it spacer (5), spring-holding plate (2), membrane (3) and diaphragm counter-disc (6).
- 2) Tighten and punch hexagonal nut (4). 200 diameter servo control has no nut (4), but the same diaphragm counterdisc (6) works like a closing nut.
- 3) Place the thus assembled servo control shaft (10) on the upper head (22).
- 4) Place membrane (3) so that its screw holes match the upper head screw holes.
- 5) Insert springs (1) into spring-holding plate (2), by placing them on centring bosses located on plate.
- 6) Place lower head (27) so that air holes of both heads are on the same vertical line and screw holes correspond with membrane and upper head screw holes.
- 7) Using proper instruments, press the springs go get the two heads closer. **Warning! Ensure that two heads cannot suddenly separate before being fastened with screws (23).**
- 8) Insert the plain washers (24) in the screws (23), insert screws (23) into upper head holes (22), insert plain washers (24) and spring washers (25) into screws (23) and torque tighten the hexagonal nuts (26) according to table 4 on page 26.
- 9) Insert BA (9) and OR gasket (7) into jig bushing (8).
- 10) Insert jig bushing assembled (8) on servo control shaft (10) and lower head (27).
- 11) Now, servo control is completely assembled and can be re-located on valve frame.

Sectional view of the FFF/10/REG DN 15#50 NO control valve

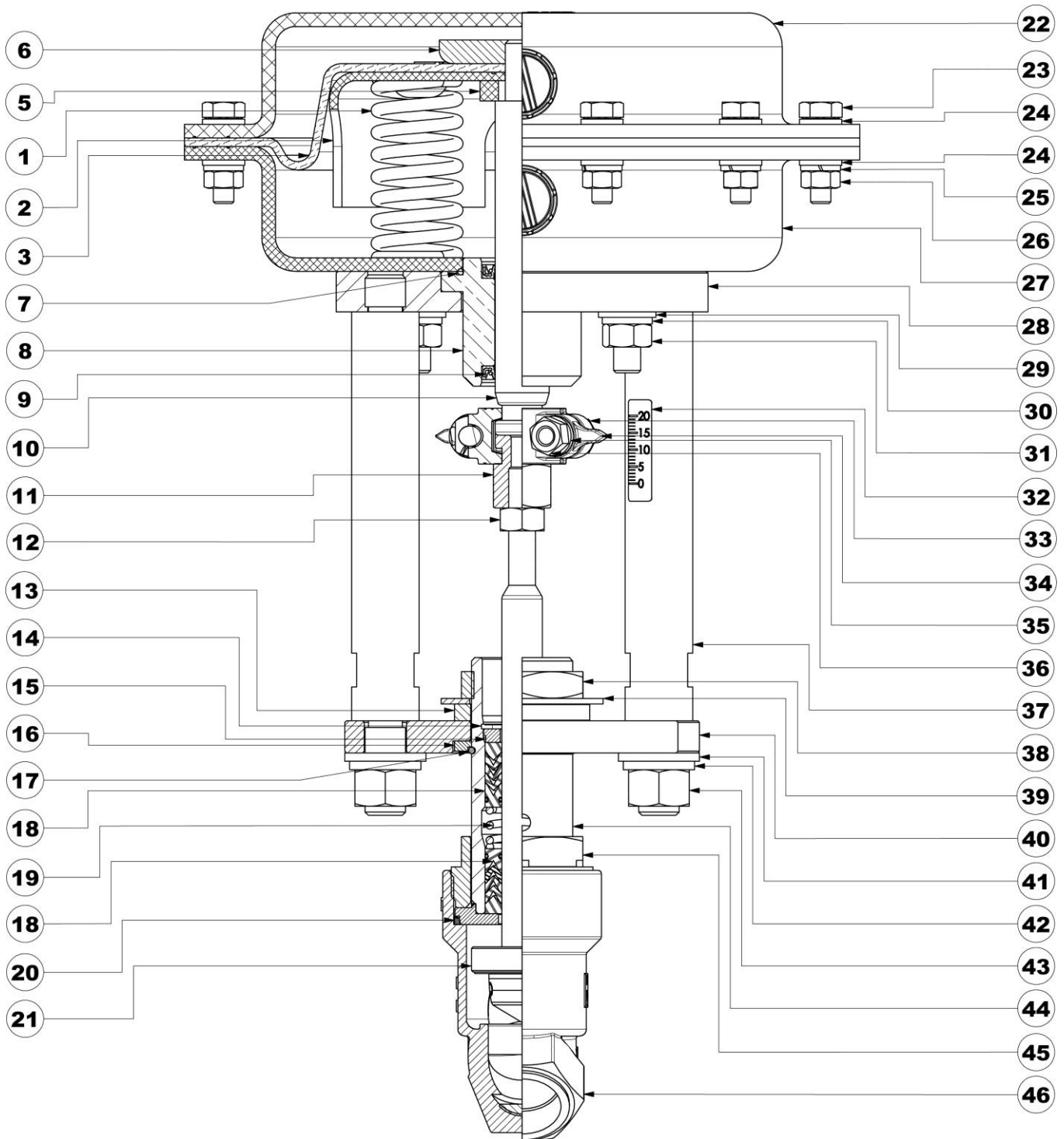

Drawing No. 120062 Rev: 00

5.10 Instructions for the disassembly, the gasket replacement and the reassembly of the FFF/10/REG DN 15#50 control valve bodies

For information about the disassembly and assembly operations of the FFF/10/REG DN 15#50 control valves please refer to the annexed dwg. no. 100785 .

Assembly and disassembly operations shall be carried out only by personnel qualified in hydraulics and pneumatics, provided with all the necessary work and safety equipment. Before carrying out any operation on systems and valves, get acquainted with operating temperatures and pressures and any other particular conditions, and take the relevant safety measures.

Whenever operations are to be carried out on valves, remove the fluid completely. The valve body shall be completely empty.

NOTE: Thoroughly read the procedures before proceeding with operation.

5.10.1 Disassembly

- 1) Separate the valve body from the servo control as described in paragraph 5.7
- 2) Unscrew the adjustment nut (11) and the nut (12) from the shutter (21). We recommend that you mark the position of the adjustment nut (11) to restore valve calibration after reinstalling it
- 3) Unscrew the closing screw (45), withdraw the intermediate body (44) with the shutter (21) from the valve body (46), then withdraw the body gasket (20) from within it.
- 4) Withdraw the shutter (21) from the intermediate body (44).
- 5) Extract the seeger ring (14). **Warning! Attention! The seeger ring (14) keeps the packing gland spring (19) compressed;** maximum care shall then be taken to prevent the spring and the packing gland from coming out suddenly during the disassembly operations.
- 6) Remove the packing gland washer (15), the first packing gland (18), the spring (19) and the second packing gland (18).
- 7) Now the valve body has been completely disassembled, so that the required components can be replaced.

5.10.2 Reassembly.

- 1) Insert into the partially assembled intermediate body (44) the first packing gland (18), the packing gland spring (19), the second packing gland (18) and finally the packing gland washer (15).
- 2) Apply the seeger ring (14). **Warning! The seeger ring keeps the packing gland spring compressed. Maximum care shall then be taken to prevent the parts located on the spring from coming out suddenly during the assembly operations.**
- 3) Insert the shutter (21) into the previously assembled intermediate body (44), carefully greasing it with silicone grease.
- 4) Place into the valve body (46) the body gasket (20), carefully greasing the body thread with silicone grease.
- 5) Insert the shutter (21) with the intermediate body (44) into the valve body (46) and tighten the closing screw (45) to the torque prescribed in Table 4 on page 26, paying attention to keep the position of the lower flange (40) perpendicular to the connectors on the valve body (46).
- 6) Place precharge adjustment nut (11) in the position kept before valve disassembly to obtain the same calibration, then fasten by nut (12).
- 7) Now the valve body is fully reassembled and can be added to the servo control as described in paragraph 5.7

Exploded view of the FFF/10/REG DN 15#50 NC control valve

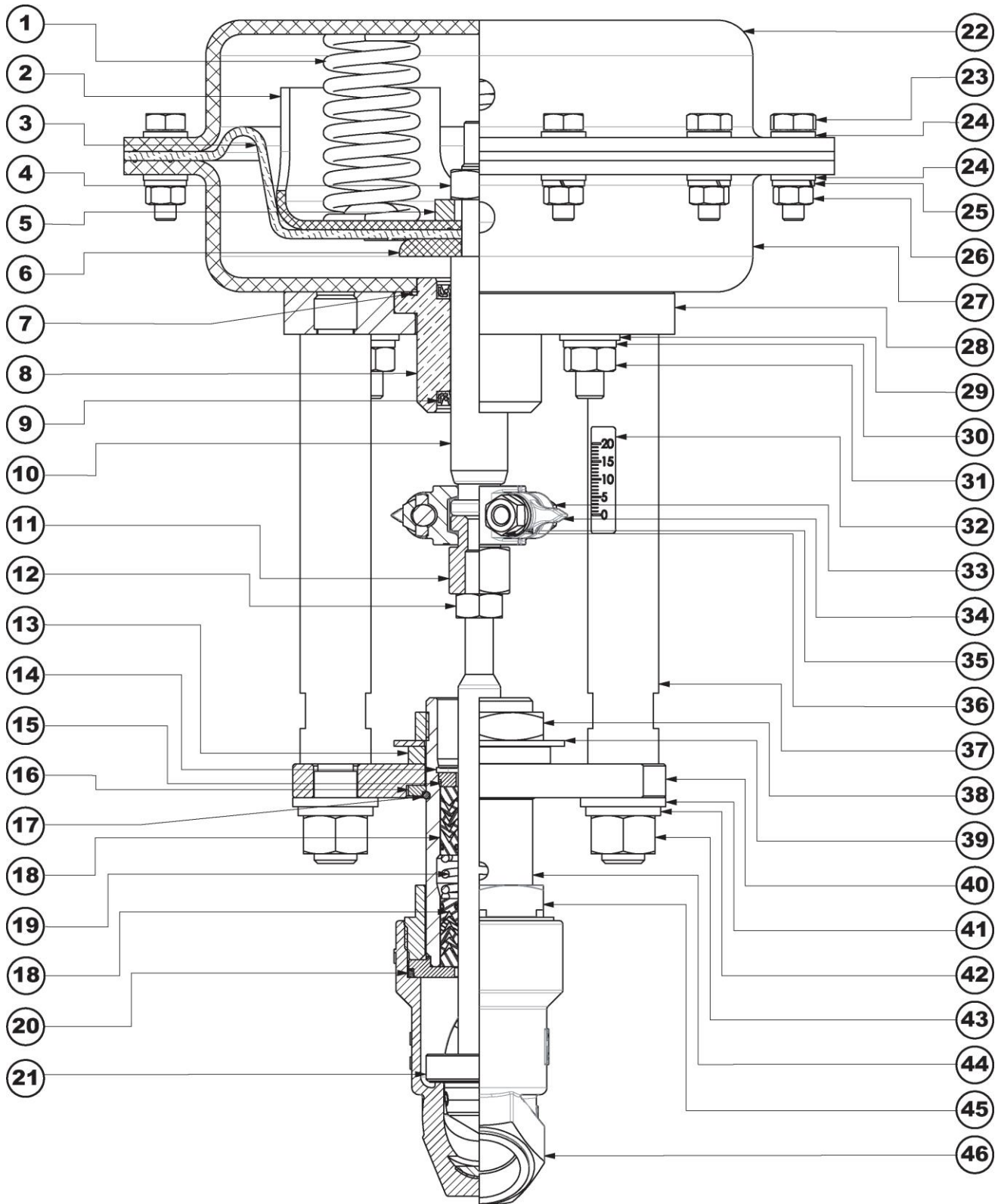

Drawing No. 100785 Rev: 00

5.11 Instructions for the disassembly, the gasket replacement and the reassembly of the FFF/10/REG DN 65 control valve bodies

For information about the disassembly and assembly operations of the FFF/10/REG DN 65 control valve please refer to the annexed dwg. no. 120061 .

Assembly and disassembly operations shall be carried out only by personnel qualified in hydraulics and pneumatics, provided with all the necessary work and safety equipment. Before carrying out any operation on systems and valves, get acquainted with operating temperatures and pressures and any other particular conditions, and take the relevant safety measures.

Whenever operations are to be carried out on valves, remove the fluid completely.

NOTE: Thoroughly read the procedures before proceeding with operation.

5.11.1 Disassembly

- 1) Separate the valve body from the servo control as described in paragraph 5.7
- 2) Unscrew the adjustment nut (11) and the nut (12) from the shutter (21). We recommend that you mark the position of the adjustment nut (11) to restore valve calibration after reinstalling it.
- 3) Untighten the screws (49) and separate them from the nuts (48) and from the spring washers (47).
- 4) Withdraw the intermediate body (44) with the shutter (21) from the valve body (46), then withdraw the body gasket (20).
- 5) Withdraw the shutter (21) from the intermediate body (44).
- 6) Extract the seeger ring (14). **Warning! Attention! The seeger ring (14) keeps the packing gland spring (19) compressed;** maximum care shall then be taken to prevent the spring and the packing gland from coming out suddenly during the disassembly operations.
- 7) Remove the packing gland washer (15), the first packing gland (18), the spring (19) and the second packing gland (18).
- 8) Now the valve body has been completely disassembled and the required components can be replaced.

5.11.2 Reassembly

- 1) Insert into the partially assembled intermediate body (44) the first packing gland (18), the packing gland spring (19), the second packing gland (18) and finally the packing gland washer (15).
- 2) Apply the seeger ring (14). **Warning! The seeger ring keeps the packing gland spring compressed. Maximum care shall then be taken to prevent the parts located on the spring from coming out suddenly during the assembly operations.**
- 3) Insert the shutter (21) into the previously assembled intermediate body (44), carefully greasing it with silicone grease.
- 4) Place onto the flange of the valve body (46) the body gasket (20), then insert the intermediate body (44) with the shutter (21), arranging them so that the screw holes match each other.
- 5) Insert the screws (43) into the intermediate body holes (44) and the spring washers (47), then tighten the hexagonal nuts (48) to the torque prescribed in Table 4 on page 26.
- 6) Place precharge adjustment nut (11) in the position kept before valve disassembly to obtain the same calibration, then fasten by nut (12).
- 7) Now the valve body is fully reassembled and can be added to the servo control as described in paragraph 5.7

Exploded view of the FFF/10/REG DN 65 NO control valve

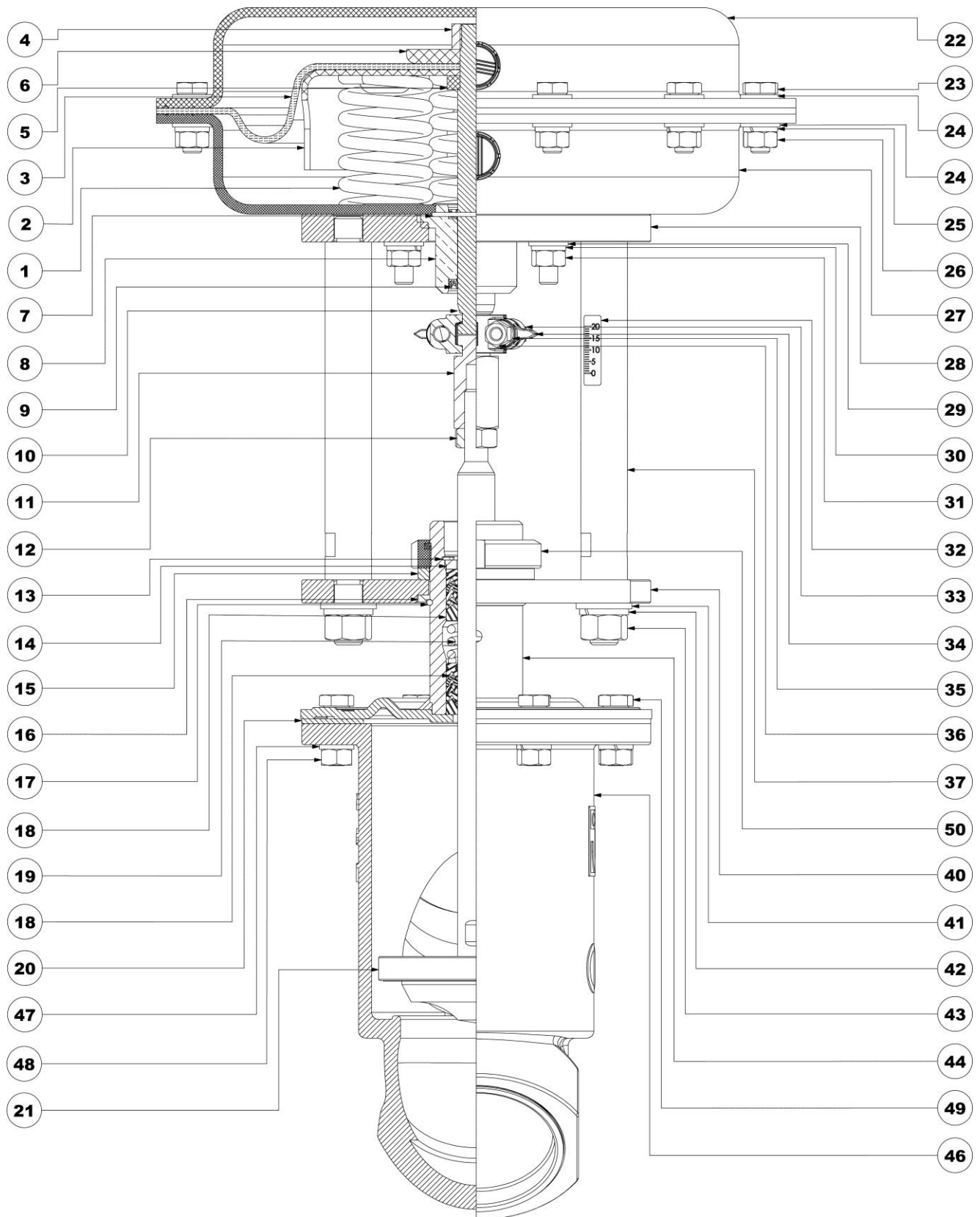

Drawing No. 120061 Rev: 00

5.12 Components and spare parts of the FFF/10/REG DN 15#50 NC./NO. control valve

No.	DESCRIPTION	MATERIALS	
		Fe HEADS	STAINLESS STEEL HEADS
1	Servo control springs	SPRING STEEL	
2	Spring-holding plate	Fe - P04	
3	Membrane	NBR rubber fabric	
4	Hexagon nut	Galvanized STEEL CL.8	
5	Distance ring washer	S30400	
6	Holding washer	Galvanized ASTM A105	
7	Or gasket	NBR	
8	Jig bushing	BRASS	Galvanized BRASS
9	BA gasket	NBR	
10	Servo control stem	S30400	
11	Preload adjustment nut	S42000	
12	Hexagon nut	S30400	
13	Distance ring washer	S30400	
14	Seeger ring	S30400	
15	Packing gland washer	S30400	
16	Outer washer	S30400	
17	Shoulder ring	HARMONIC STEEL	
18	Packing gland	PTFE + PTFE/GRAPHITE + FPM	
19	Packing gland spring	S31600	
20	Body gasket	PTFE	
21	Shutter	S31600 + PTFE	
		S31600 + EPDM HT coated with PTFE	
		S31600 + EPDM HT	
		S31600 + EPDM HT	
22	Upper head	Fe - P04	ASTM A240 304 PS
23	Hexagonal-head screw	Galvanized CL.8.8 STEEL	S30400
24	Plain washer	Galvanized STEEL	S30400
25	Spring washer	Galvanized STEEL	S30400
26	Hexagon nut	Galvanized STEEL CL.8	S30400
27	Lower head	Fe - P04 + copper STEEL	ASTM A240 304 PS
28	Upper flange	S30400	
29	Plain washer	Galvanized	S30400
30	Spring washer	Galvanized	S30400
31	Hexagon nut	Galvanized	S30400
32	Stroke label	POLYESTER	
33	Hexagonal-head screw	S30400	
34	Clamp	CF8	
35	Spring washer	S30400	
36	Hexagon nut	S30400	
37	Spacer column	S30400	
38	Locking nut	S30400	
39	Safety washer	S30400	
40	Lower flange	S30400	
41	Plain washer	S30400	
42	Spring washer	S30400	
43	Hexagon nut	S30400	
44	Intermediate body	S30400+S31600	
45	Closing screw	CF8	
46	Valve body	CF8M	

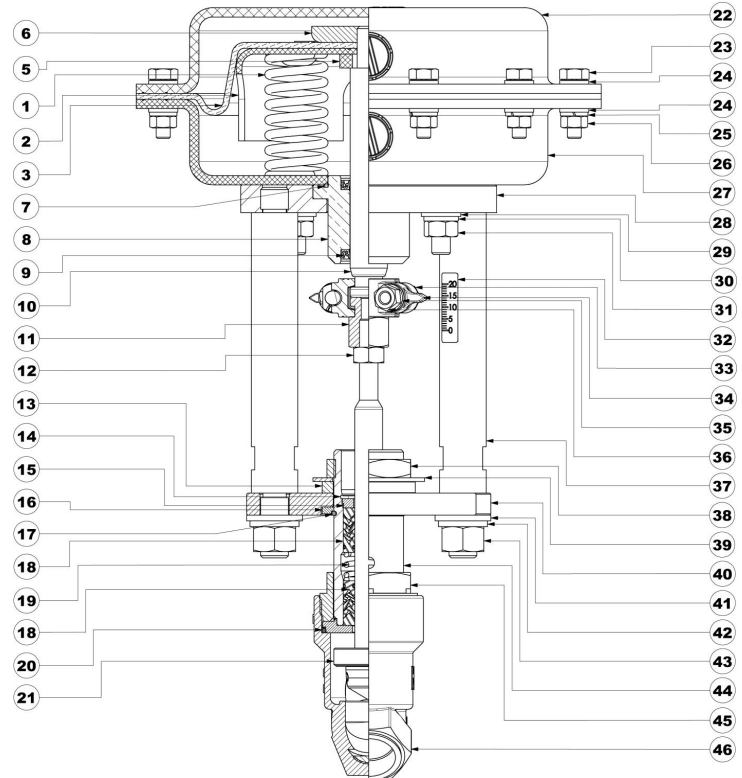

Body side spare parts

DN	SPARE PART CODE (Part. No. 18/19/20)
15	14720
20	14721
25	14722
32	14723
40	14724
50	14725

Air side spare parts

servo control Ø	SPARE PART CODE (Part. No. 3/7/9)
Ø 200	2655
Ø 275	5401
Ø 360	5402
Ø 430	5403

5.13 Components and spare parts of the FFF/10/REG DN 65 NC./NO. control valve

No.	DESCRIPTION	MATERIALS	
		Fe HEADS	STAINLESS STEEL HEADS
1	Servo control springs	SPRING STEEL	
2	Spring-holding plate	Fe - P04	
3	Membrane	NBR rubber fabric	
4	Hexagon nut	Galvanized STEEL CL.8	
5	Distance ring washer	S30400	
6	Holding washer	Galvanized ASTM A105	
7	Or gasket	NBR	
8	Jig bushing	BRASS	Galvanized BRASS
9	BA gasket	NBR	
10	Servo control stem	S30400	
11	Preload adjustment nut	S42000	
12	Hexagon nut	S30400	
13	Distance ring washer	S30400	
14	Seeger ring	S30400	
15	Packing gland washer	S30400	
16	Outer washer	S30400	
17	Shoulder ring	HARMONIC STEEL	
18	Packing gland	PTFE + PTFE/GRAPHITE + FPM	
19	Packing gland spring	S31600	
20	Body gasket	PTFE	
21	Shutter	S31600 + PTFE	
		S31600 + EPDM HT coated with PTFE	
		S31600 + EPDM HT	
22	Upper head	Fe - P04	ASTM A240 304 PS
23	Hexagonal-head screw	Galvanized STEEL CL.8.8	S30400
24	Plain washer	Galvanized STEEL	S30400
25	Spring washer	Galvanized STEEL	S30400
26	Hexagon nut	Galvanized STEEL CL.8	S30400
27	Lower head	Fe - P04 + copper STEEL	ASTM A240 304 PS
28	Upper flange	S30400	
29	Plain washer	Galvanized STEEL	S30400
30	Spring washer	Galvanized STEEL	S30400
31	Hexagon nut	Galvanized STEEL CL.8	S30400
32	Stroke label	POLYESTER	
33	Hexagonal-head screw	S30400	
34	Clamp	CF8	
35	Spring washer	S30400	
37	Spacer column	S30400	
39	Safety washer	S30400	
40	Lower flange	S30400	
41	Plain washer	S30400	
42	Spring washer	S30400	
43	Hexagon nut	S30400	
44	Intermediate body	S30400+S31600	
45	Closing screw	CF8	
46	Valve body	CF8M	
47	Spring washer	S30400	
48	Hexagon nut	S30400	
49	Hexagonal-head screw	S30400	
50	Self-locking ring	S30400	

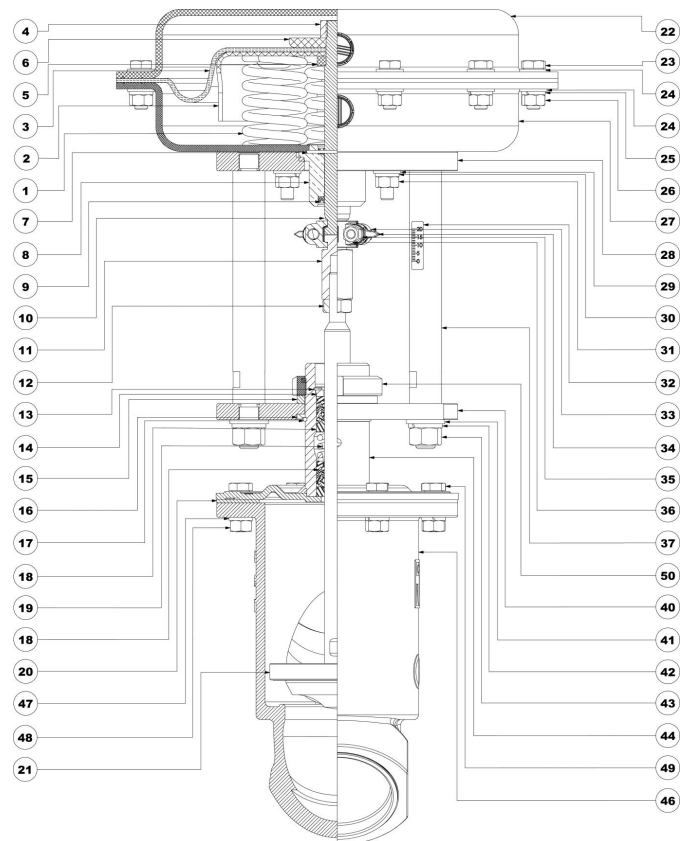

Body side spare parts

DN	SPARE PART CODE (Part. No. 18/19/20)
65	14726

Air side spare parts

servo control Ø	SPARE PART CODE (Part. No. 3/7/9)
Ø 200	2655
Ø 275	5401
Ø 360	5402
Ø 430	5403

6 Table 3: Servo control springs

Øe SERV	STROKE (mm)	SIGNAL							
		3 ÷ 15		6 ÷ 18		6 ÷ 30		9 ÷ 32	
		No.	CODE	No.	CODE	No.	CODE	No.	CODE
200	15	3	MTD086100	3	MTD086101	6	MTD086100	6	MTD086102
	20		MOLL110523		MOLL100804		MOLL110523		
275	15	3	MTD086106	6	MTD086107	6	MTD086106	6	MTD086108
	20		MOLL100528		MOLL100529		MOLL100528		MOLL100530
360	15	6	MTD086106	12	MTD086107	12	MTD086106	12	MTD086108
	20		MOLL100528		MOLL100529		MOLL100528		MOLL100530
430	15	4	MTD086103	8	MTD086104	8	MTD086103	8	MTD086105
	20		MOLL100532		MOLL100533		MOLL100532		MOLL100534

7 Table 4: Tightening Torques

Part match	Tightening torque for FFF/10/REG control valve threaded couplings [N·m]										
	Servo Control Couplings Ø _{and} Servo				Body couplings DN						
	200	275	360	430	15	20	25	32	40	50	65
Part 23 – Part. 26	12	17									
Part 31 – Part. 27	17										
Part 38					100						
Part 47 – Part. 49					165	270	358	490			
Part 47 – Part. 49											
Part 50											
System connections					40	65	120	195	255	500	

8 Valve life

The FFF/10/REG-series control valve has been designed and manufactured to ensure proper operation under the conditions and limits provided for by the technical characteristics.

All fastened metal parts not involved in sealing have an expected life of 10 years. Sealing and moving parts must be subject to complete overhaul within a time interval shorter than 500000 manoeuvres and three years.

This overhaul operation can be carried out by specialized personnel only.

Scheduled maintenance operations shall be carried out independently of the ones due to possible failures, which always require an immediate intervention.

9 Disposal

After use, for the valve disposal, it is necessary to disassemble the valve and separate the different materials the valve is composed of, according to the tables annexed to the valve working drawings, then dispose of the different materials in compliance with the laws in force.

Assembly and disassembly operations shall be carried out by qualified personnel only, equipped with all the work and safety tools. **WARNING! Compressed springs are included inside the servo control.** Thus, during valve disassembly, components are disposed of by using all safety equipment necessary to prevent sudden separation of upper head from lower head when all servo control head fastening screws have been removed.

10 Warranty

Each valve is tested before leaving the factory. Following a request by the customer we can issue the testing certificate. The customer may inspect and test in person the material at our site, before shipping. This inspection is considered as final. All the charges associated with special testing or requests by the customer shall be paid by the customer himself.

Our responsibility is limited to the replacement or repair of any components that should turn out to have any material or manufacturing defects, within 12 months of shipping and used under normal operating conditions. This commitment excludes any other obligation.

All the transport and accessory expenses, anyway, shall be paid by the customer. ITALVALVOLE® reserves the right to stop or change or modify the characteristics and the manufacturing of any of its products without incurring any obligation to replace or install on the already supplied products the modified parts.

WARNINGS:

- The safety conditions shall not be guaranteed and malfunctions shall not be subjected to valves in case:
 - disassembly, re-assembly, maintenance operations are not carried out in compliance with the use and maintenance manual.
 - original spare parts are not used.
- It is forbidden to remove pages from this document or to make any correction.
- ITALVALVOLE® S.A.S. reserves the right to change its products and the relevant documentation without prior notice.
- The use of the handbook does not exempt from the observance of the laws in force.
- We inform you that some components may come from countries other than Italy.