



AUTHORISED  
EXPORTER  
N° IT/004/BI/15

**italvalvole®** s.a.s.

di SPADON OSCAR & C.

## Guide to selection, use and maintenance of cast iron SBS/10 valves

CODE	12872
CATEG.	1770
GROUP	900
REVISION	12
DATE	15/02/2018

# CAST IRON SBS/10 VALVES

## FAMILY 04 – GROUPS 120 – 121 - 122 - 123

Master handbook description: Guide to selection, use and maintenance of  
cast iron SBS/10 valves (English)

Code: 12872

Category: 1770

Group: 900

Revision n°.:12

Date: 15/02/2018

Written by: AR

Checked by: LR

Approved by: OS



IT AEOF 15 0974



ISO 9001 - Cert. n° 0302



Cert. PED N° 002-97/23/CE-D  
Cert. PED N° PA001-97/23/CE-B

DIRECTIVE 2014/34/EU  
CERTIFICATE N° 0425 ATEX 2519  
CERTIFICATE N° 0425 ATEX 1318



# DICHIARAZIONE DI CONFORMITA' UE

## DECLARATION OF UE CONFORMITY

Mod: 701  
Rev: 02  
Data: 18/07/2017

### VALVOLE A GLOBO DI REGOLAZIONE SERIE SBS MODULATING GLOBE VALVES SERIES SBS

(in tutte le sue configurazioni / in all their configurations)

La presente dichiarazione di conformità è rilasciata sotto la responsabilità esclusiva del fabbricante.  
*This declaration of conformity is issued under the sole responsibility of the manufacturer.*

**ITALVALVOLE®** s.a.s. di Spadon Oscar & C. dichiara che questa serie di prodotti è stata progettata e costruita in accordo a quanto indicato nell'ALLEGATO I della direttiva UE:

**ITALVALVOLE®** s.a.s. of Spadon Oscar & C. declare that this series of products it was engineered and built in according as indicated on Annex 1 of the directive UE:

**2014/68/UE**

CLASSIFICAZIONE DELLE VALVOLE / CLASSIFICATION OF THE VALVES

**CATEGORIA I** per fluidi del gruppo **II** - **CATEGORY I** for fluids group **II**

Secondo valutazione di conformità descritte dall' allegato III (MODULO A)  
*With respect to the conformity described in annex III (MODULE A)*

NORME TECNICHE ARMONIZZATE e SPECIFICHE UTILIZZATE:  
*HARMONISED TECHNICAL STANDARDS and SPECIFICATIONS USED:*

**UNI EN 1092-1-2 / UNI EN 12266-1-2 / UNI EN 1561 / UNI EN 1563 / UNI EN 10213**

ALTRE DIRETTIVE EUROPEE APPLICATE:  
*OTHER EUROPEAN STANDARDS APPLIED:*

**2014/34/UE**

Marcatura dell'apparecchiatura:  
*Marking of equipment:*

  II 2 GD Ex h IIC Tx Gb  
  II 2 GD Ex h IIC Tx Db

NORME TECNICHE ARMONIZZATE e SPECIFICHE UTILIZZATE:  
*HARMONISED TECHNICAL STANDARDS and SPECIFICATIONS USED:*

**EN ISO 80079-36:2016 / EN ISO 80079-37: 2016**

Attestato di archiviazione del fascicolo:  
*Certificate of the technical file storage:*

**0425 ATEX 1318-01**

ENTE NOTIFICATO – NOTIFIED BODY

**ICIM S.p.a**

Via Don Enrico Mapelli, 75 – 20099 Sesto San Giovanni (MI)  
Numero Identificativo dell'Organismo Notificato  
*Notified Body Identification Number:*

**0425**

LUOGO e DATA - Place and Date  
Cossato, 18/07/2017

Legale rappresentante  
*Legal representative*

## Table of contents

<b>DICHIARAZIONE DI CONFORMITA' UE</b> .....	<b>2</b>
<b>1 Foreword</b> .....	<b>6</b>
<b>2 Legend</b> .....	<b>6</b>
<b>3 Inquiries</b> .....	<b>7</b>
<b>4 Technical features</b> .....	<b>7</b>
<b>4.1 Examples of design calculations</b> .....	<b>8</b>
<b>4.2 Pressures/Temperature ratios of SBS/10 cast iron bodies</b> .....	<b>8</b>
<b>4.3 Example of linear and equal percentage shutters features of SBS/10 valves stroke 15</b> .....	<b>8</b>
<b>4.4 Table 1: Compatible Fluids</b> .....	<b>9</b>
<b>4.5 Table 2: <math>\Delta p</math> of SBS/10 2-way valves without bellows</b> .....	<b>10</b>
<b>4.6 Table 2: <math>\Delta p</math> of SBS/10 2-way valves with bellows</b> .....	<b>12</b>
<b>4.7 Table 4: Kv of SBS/10 2-way valves</b> .....	<b>14</b>
<b>4.8 Safety Notes</b> .....	<b>15</b>
<b>4.9 Overall dimensions of SBS/10 valves</b> .....	<b>16</b>
4.9.1 SBS/10 2-way cast iron.....	16
4.9.2 SBS/10 3-way cast iron.....	17
4.9.3 SBS/10 2-way cast iron with safety bellows.....	18
4.9.4 SBS/10 3-way cast iron with safety bellows.....	19
<b>5 SBS/10 tags description</b> .....	<b>20</b>
<b>6 Storage, Assembly, Check And Maintenance</b> .....	<b>22</b>
<b>6.1 Transport, Storage and Handling</b> .....	<b>22</b>
<b>6.2 Assembly Instructions</b> .....	<b>22</b>
6.2.1 General information .....	22
6.2.2 Installation of valve on the plant.....	22
<b>6.3 Installation diagrams</b> .....	<b>23</b>
6.3.1 Installation of SBS/10 2-way valves .....	23
6.3.2 Installation of SBS/10 3-way deviator valves .....	23
6.3.3 Installation of SBS/10 3-way mixer valves .....	24
<b>6.4 Operation Test</b> .....	<b>25</b>
<b>6.5 Troubleshooting</b> .....	<b>25</b>
6.5.1 Fluid passage with valve closed.....	25
6.5.2 Diaphragm (membrane) .....	25
<b>6.6 Scheduled Maintenance</b> .....	<b>25</b>
<b>6.7 Disassembly and assembly instructions for SBS/10 ND 15#50 2-way NC valve</b> .....	<b>26</b>
6.7.1 Disassembly .....	26
6.7.2 Reassembly .....	26
<b>6.8 Disassembly and assembly instructions for SBS/10 ND 65#80 2-way NC valve</b> .....	<b>28</b>
6.8.1 Disassembly .....	28
6.8.2 Reassembly .....	28
<b>6.9 Disassembly and assembly instructions for SBS/10 ND 15#50 2-way NO valve</b> .....	<b>30</b>

6.9.1	Disassembly .....	30
6.9.2	Reassembly .....	30
<b>6.10</b>	<b>Disassembly and assembly instructions for SBS/10 ND 65#80 2-way NO valve .....</b>	<b>32</b>
6.10.1	Disassembly .....	32
6.10.2	Reassembly .....	32
<b>6.11</b>	<b>Disassembly and assembly instructions for SBS/10 ND 15#50 3-way NC mixer valve .....</b>	<b>34</b>
6.11.1	Disassembly .....	34
6.11.2	Reassembly .....	34
<b>6.12</b>	<b>Disassembly and assembly instructions for SBS/10 ND 65#80 3-way NC mixer valve .....</b>	<b>36</b>
6.12.1	Disassembly .....	36
6.12.2	Reassembly .....	36
<b>6.13</b>	<b>Disassembly and assembly instructions for SBS/10 ND 15#50 3-way NO mixer valve .....</b>	<b>38</b>
6.13.1	Disassembly .....	38
6.13.2	Reassembly .....	38
<b>6.14</b>	<b>Disassembly and assembly instructions for SBS/10 ND 65#80 3-way NO mixer valve .....</b>	<b>40</b>
6.14.1	Disassembly .....	40
6.14.2	Reassembly .....	40
<b>6.15</b>	<b>Disassembly and assembly instructions for SBS/10 ND 15#50 3-way NC deviator valve .....</b>	<b>42</b>
6.15.1	Disassembly .....	42
6.15.2	Reassembly .....	42
<b>6.16</b>	<b>Disassembly and assembly instructions for SBS/10 ND 65#80 3-way NC deviator valve .....</b>	<b>44</b>
6.16.1	Disassembly .....	44
6.16.2	Reassembly .....	44
<b>6.17</b>	<b>Disassembly and assembly instructions for SBS/10 ND 15#50 3-way NO deviator valve .....</b>	<b>46</b>
6.17.1	Disassembly .....	46
6.17.2	Reassembly .....	46
<b>6.18</b>	<b>Disassembly and assembly instructions for SBS/10 ND 65#80 3-way NO deviator valve .....</b>	<b>48</b>
6.18.1	Disassembly .....	48
6.18.2	Reassembly .....	48
<b>6.19</b>	<b>Disassembly and assembly instructions for SBS/10 ND 15#50 2-way NC valve with bellows .....</b>	<b>50</b>
6.19.1	Disassembly .....	50
6.19.2	Reassembly .....	50
<b>6.20</b>	<b>Disassembly and assembly instructions for SBS/10 ND 65#80 2-way NC valve with bellows .....</b>	<b>52</b>
6.20.1	Disassembly .....	52
6.20.2	Reassembly .....	52
<b>6.21</b>	<b>Disassembly and assembly instructions for SBS/10 ND 15#50 2-way NO valve with bellows .....</b>	<b>54</b>
6.21.1	Disassembly .....	54
6.21.2	Reassembly .....	54
<b>6.22</b>	<b>Disassembly and assembly instructions for SBS/10 ND 65#80 2-way NO valve with bellows .....</b>	<b>56</b>
6.22.1	Disassembly .....	56
6.22.2	Reassembly .....	56
<b>6.23</b>	<b>Disassembly and assembly instructions for SBS/10 3-way NC mixer valve with bellows .....</b>	<b>58</b>
6.23.1	Disassembly .....	58
6.23.2	Reassembly .....	58
<b>6.24</b>	<b>Disassembly and assembly instructions for SBS/10 3-way NO mixer valve with bellows .....</b>	<b>60</b>
6.24.1	Disassembly .....	60
6.24.2	Reassembly .....	60
<b>6.25</b>	<b>Disassembly and assembly instructions for SBS/10 3-way NC deviator valve with bellows .....</b>	<b>62</b>
6.25.1	Disassembly .....	62

6.25.2 Reassembly .....	62
<b>6.26 Disassembly and assembly instructions for SBS/10 3-way NO deviator valve with bellows .....</b>	<b>64</b>
6.26.1 Disassembly .....	64
6.26.2 Reassembly .....	64
<b>6.27 Disassembly and assembly instructions for SBS/10 NC servo control .....</b>	<b>66</b>
6.27.1 Disassembly .....	66
6.27.2 Reassembly .....	66
<b>6.28 Disassembly and assembly instructions for SBS/10 NO servo control .....</b>	<b>68</b>
6.28.1 Disassembly .....	68
6.28.2 Reassembly .....	68
<b>6.29 Instructions for disassembly, gasket replacement, reassembly of SBS/10 2-way T.PK. shutters .....</b>	<b>70</b>
6.29.1 Disassembly .....	70
6.29.2 Assembly .....	70
6.29.3 T.P. 2-way shutter diagram .....	70
<b>6.30 Instructions for disassembly, gasket replacement, reassembly of SBS/10 3-way T.PK. mixer .....</b>	<b>71</b>
6.30.1 Disassembly .....	71
6.30.2 Assembly .....	71
6.30.3 T.P. 3-way mixer shutter diagram .....	71
<b>6.31 Instructions for disassembly, gasket replacement, reassembly of shutters for SBS/10 3-way T.PK. deviator .....</b>	<b>72</b>
6.31.1 Disassembly .....	72
6.31.2 Assembly .....	72
6.31.3 T.P. 3-way deviator shutter diagram .....	72
<b>6.32 Instructions for disassembly, gasket replacement, reassembly of shutters for SBS/10 3-way deviator .....</b>	<b>73</b>
6.32.1 Disassembly: 1st part .....	73
6.32.2 Disassembly: 2nd part .....	73
6.32.3 Assembly: 1st part .....	73
6.32.4 Assembly: 2nd part .....	73
6.32.5 3-way deviator bellow shutter diagram .....	73
<b>6.33 Parts and spare parts SBS/10 ND 15#50 2-WAY N.C./N.O. ....</b>	<b>74</b>
<b>6.34 Parts and spare parts SBS/10 ND 65#80 2-WAY N.C./N.O. ....</b>	<b>75</b>
<b>6.35 Parts and spare parts SBS/10 ND 15#50 3-WAY N.C./N.O. mixer .....</b>	<b>76</b>
<b>6.36 Parts and spare parts SBS/10 ND 65#80 3-WAY N.C./N.O. mixer .....</b>	<b>77</b>
<b>6.37 Parts and spare parts SBS/10 ND 15#50 3-WAY N.C./N.O. deviator .....</b>	<b>78</b>
<b>6.1 Parts and spare parts SBS/10 ND 65#80 3-WAY N.C./N.O. deviator .....</b>	<b>79</b>
<b>6.2 Parts and spare parts SBS/10 ND 15#50 2-WAY N.C./N.O. with bellows .....</b>	<b>80</b>
<b>6.1 Parts and spare parts SBS/10 ND 65#80 2-WAY N.C./N.O. with bellows .....</b>	<b>81</b>
<b>6.2 Parts and spare parts SBS/10 3-way N.C./N.O. mixer with bellows .....</b>	<b>82</b>
<b>6.3 Parts and spare parts SBS/10 3-way N.C./N.O. deviator with bellows .....</b>	<b>83</b>
<b>7 Table 5: Servo control springs .....</b>	<b>84</b>
<b>8 Table 6: Tightening Torques .....</b>	<b>84</b>
<b>9 Valve life .....</b>	<b>84</b>
<b>10 Disposal .....</b>	<b>84</b>
<b>11 Warranty .....</b>	<b>85</b>

## 1 Foreword

SBS/10 valves have been created to further improve a product already consolidated in versions /86 and /06.

With the support of analysis programs such as FLOWorks and COSMOSWorks, our technical staff has been committed in improving fluid-dynamic properties of new valves, re-designing their bodies and shutters to improve their final Kv and provide for better performance to customers.

Valves with diaphragm servomotor have been conceived to check the flow of overheated water, liquids, gas and steam in pipes.

SBS/10-series control valve are the basic element of flow rate control (as a consequence, of temperature and pressure control) for a fluid, within the process in an automatic plant.

Even though the valve operating principle and its main features are the same (manufacturing structure, dimensions, power and control forces in servo control have remained unchanged) ( $\Delta P$ ), ITALVALVOLE<sup>®</sup> has focused on the quality of materials.

- **The special feature of the new version is the integration of intermediate body into the frame, to reduce possible misalignment between seat and shutter.**
- **Stroke indicator, an AISI 304 investment casting, replaces the pressed washer and indication arrow provides clearer and immediate reading of valve stroke.**
- **2-way version of this series is delivered with guided shutter in both upper (intermediate body) and lower (seat) part. This measure ensures a longer life of sealing components, also in heavy-duty conditions.**
- **Shutters have been fully renewed and calculated by FloWorks program. This study has allowed improving performance of typical flow rate curve according to different (linear and equipercantage) profiles as shown in the following diagrams.**

Opening, closing and modulating action of valve are generated by the variation of pneumatic signal reaching the servomotor (valve pneumatic head).

Diaphragm/spring combinations delivered inside valve pneumatic head cover the following inlet signal ranges on diaphragm: 3/15 psi (0.2/1.0 bar), 6/18 psi (0.42/1.26 bar), 6/30 psi (0.42/2.1 bar), 9/32 psi (0.6/2.24 bar), 3/9 psi (0.2/0.6 bar), 9/15 psi (0.6/1.0 bar).

ITALVALVOLE<sup>®</sup> SBS/10 series control valves supplied are normally closed (N.C.) (air opening) or normally open (N.O.) (air closing).

Anyway, since servomotor is reversible, it can transform a N.C. valve into N.O. valve or viceversa by simply replacing a few details.

## 2 Legend

- $\Delta p_{\text{allowable}}$  (allowable differential pressure): maximum allowable value, at a given temperature, of the static differential pressure of a valve in closed position (EN 7363 : 1997).
- **Allowable temperature:** maximum operating temperature, prescribed for safety reasons.
- **Allowable pressure:** maximum operating pressure, normally at the top of each compartment of the pressure equipment, prescribed for safety reasons (UNI EN 764 : 1997).
- **DN:** is an alphanumeric designation of size for components of a pipework system, which is used for reference purposes.

It comprises the letters DN followed by a dimensionless whole number which is indirectly related to the physical dimension, expressed in millimetres, of the hole or of the outer diameter of the ends of connection pipes (ISO 6708: 1995).

- **Kv:** flow rate, expressed in cubic m<sup>3</sup>/h, of water (10 to 25 °C with a volume equal to 1000 Kg/m<sup>3</sup>), which goes through two ways of a valve, with a pressure drop  $\Delta p$  of 100 KPa (1 bar)

$$Kv = \frac{Q}{\sqrt{\Delta p}}$$

where: Q is the flow rate in m<sup>3</sup>/h (UNI 9753: 1990).



### 3 Inquiries

In case of specific needs or doubts, please contact our technical office after filling in the form below and the suitable type of valve to be used will be communicated to you.

DATA REQUIRED:

DN \_\_\_\_\_ PN 16  
 Two-way  Three-way deviator  Three-way mixer   
 Control signal \_\_\_\_\_  
 Shutter  linear  
            equal percentage  
            with silencer  
 Body material  grey cast iron  spheroid cast iron  
 Valve action  normally closed  
                normally open  
 Operating fluid \_\_\_\_\_ Specific weight \_\_\_\_\_ Kg/m<sup>3</sup>  
 Maximum flow rate \_\_\_\_\_ Kg/h \_\_\_\_\_ m<sup>3</sup>/h  
 Pressure upstream the valve \_\_\_\_\_ bars  
 Pressure downstream the valve \_\_\_\_\_ bars  
 Fluid temperature in °C \_\_\_\_\_  
 Standard intermediate body   
    with bellows  
 With handwheel  With pneumatic positioning device

### 4 Technical features

- General notice:** ⇒ all the pressure values indicated hereinafter are relative pressure values  
 ⇒ **valve designed for fluids of group 2 (directive 2014/68/UE).**
- DN:** ⇒ 15 – 20 – 25 – 32 – 40 – 50 – 65 – 80
- Connections:** ⇒ flanged according to PN 16 under EN 1092-2
- P<sub>max</sub> all.:** ⇒ 16 bars
- P<sub>min</sub> all.:** ⇒ 0 bar
- Seal:** ⇒ PEEK, metal and stellited (the stellited seat is suggested for Δp>10 bar)
- Seal class:** ⇒ Level A for PEEK seal, Level B for metal and stellited seal
- Shutter features:** ⇒ equal percentage, linear
- Body material:** ⇒ EN-GJL-250 and EN-GJS-500-7.
- T<sub>max</sub> all.:** ⇒ +200°C all seal, standard version  
 ⇒ +250°C with PEEK with safety bellows and body in EN-GJS-500-7.  
 ⇒ +300°C with metal or stellited seal with safety bellows and body in EN-GJS-500-7.
- T<sub>min</sub> all.:** ⇒ -10 °C (in liquid phase) standard version.
- Flow direction:** ⇒ unidirectional 2-way globe valve.  
 ⇒ 3-way globe valve, with angle body, in DEVIATOR and MIXER versions.
- Air connection:** ⇒ 1/8" GAS (head Ø 200), 1/4" GAS (head Ø 275, Ø 360, Ø 430)
- Supply fluid:** ⇒ industrial air
- Supply pipes:** ⇒ pipe inner diameter = 4 mm, min. outdoor diameter = 6 mm, able to bear the supply P<sub>max</sub> under the environmental conditions of the plant where the valve is fitted.
- Supply P:** ⇒ 3÷15 PSI, 6÷18 PSI, 6÷30 PSI, 9÷32 PSI, 3÷9 PSI, 9÷15 PSI
- Versions:** ⇒ normally closed, normally open (for three-way, it is considered as normally open when square way is open), with or without bellows, with or without emergency handwheels, with cage on shutter to reduce fluid noise level
- Stroke:** ⇒ - 2 ways DN 15,20,25 stroke 15mm.  
 ⇒ - 2 ways DN 32,40,50,65,80 stroke 20mm  
 ⇒ - 3 ways deviator stroke 20mm  
 ⇒ - 3 ways mixing stroke 15mm  
 ⇒ - 2/3 ways with bellows stroke 15mm  
 N.B. For different stroke requirement, please contact our technical department
- Manufacturing materials:** ⇒ see drawings and relevant tables
- Overall dimensions:** ⇒ see overall dimensions drawings and relevant tables



### 4.1 Examples of design calculations

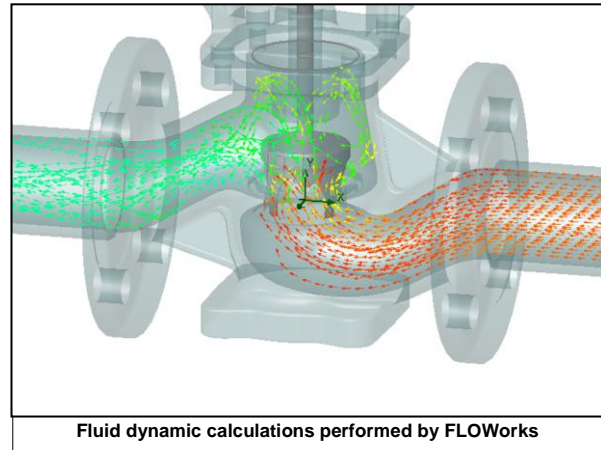
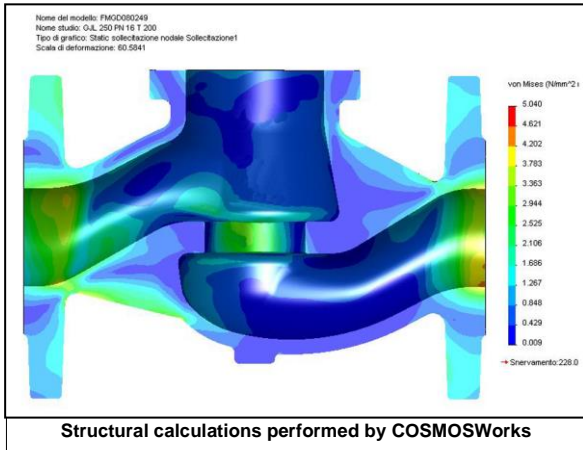

### 4.2 Pressures/Temperature ratios of SBS/10 cast iron bodies

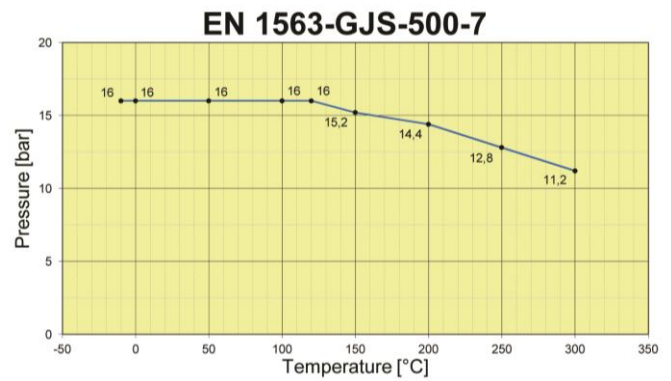
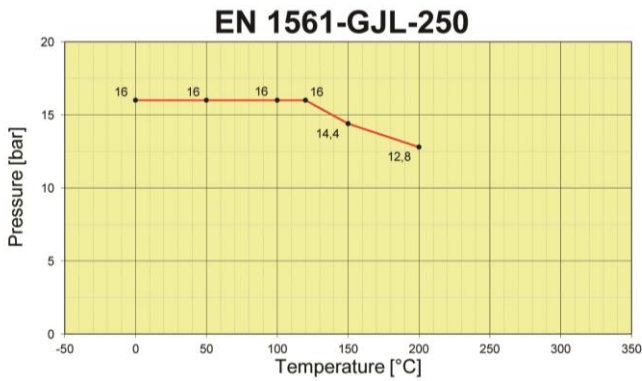

### 4.3 Example of linear and equal percentage shutters features of SBS/10 valves stroke 15

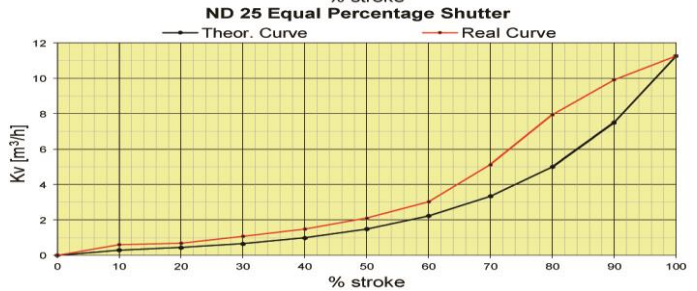
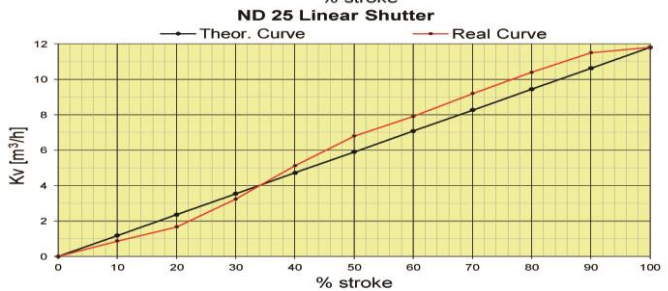
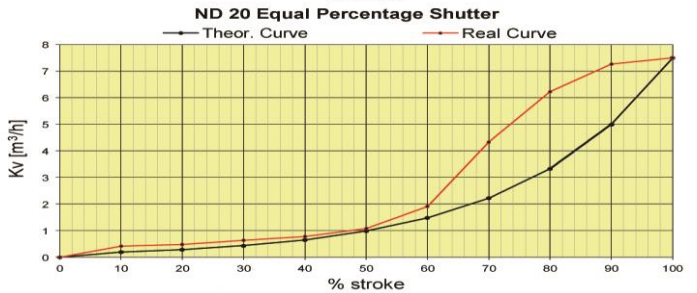
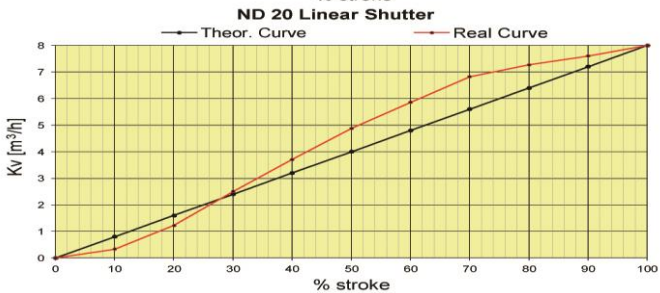
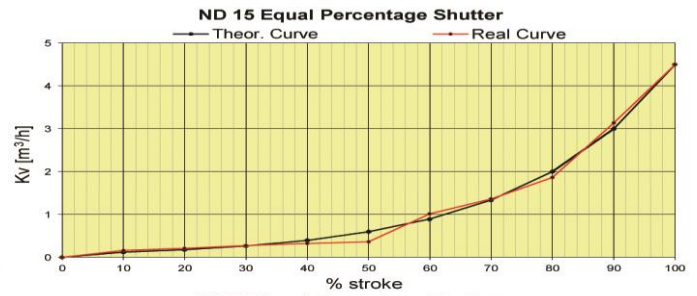
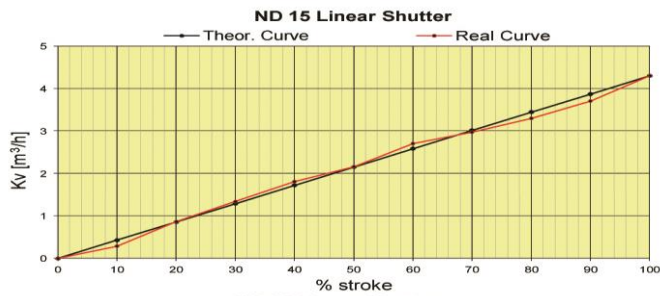



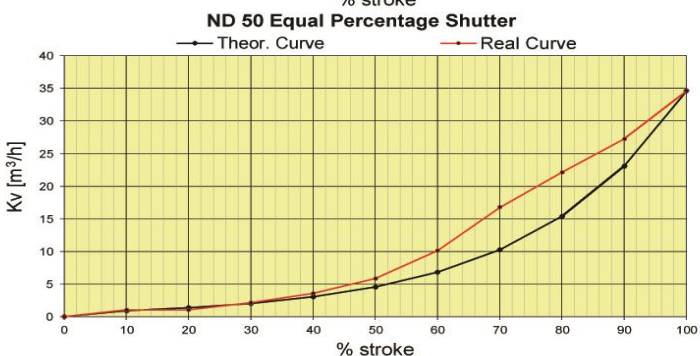
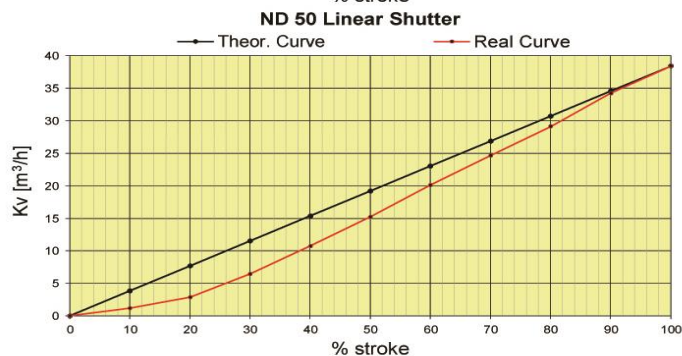
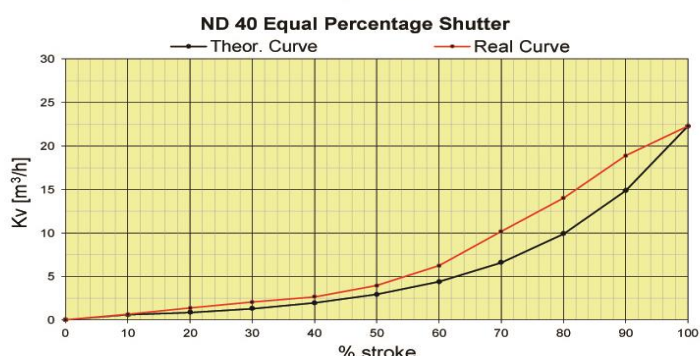
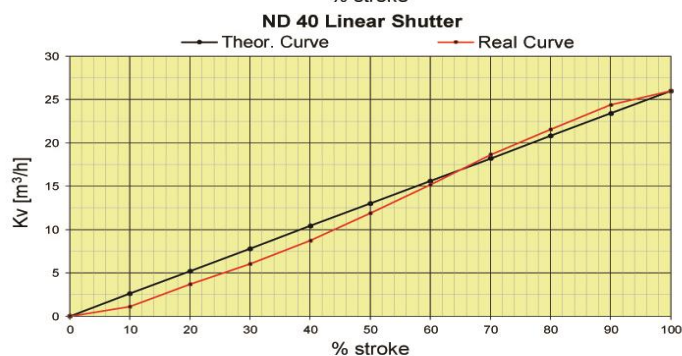
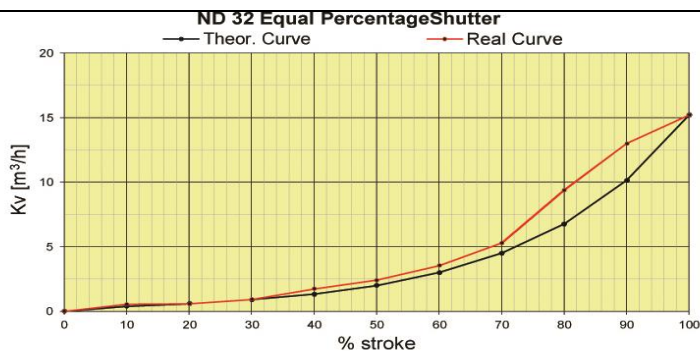
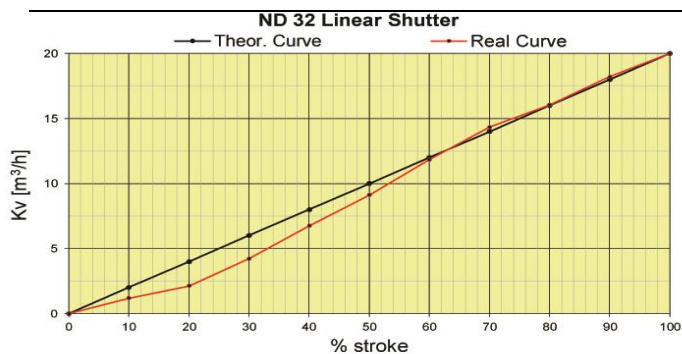

#### 4.4 Table 1: Compatible Fluids

Type of fluid	Comp.	Type of fluid	Comp.
Linoleic acid	YES	Magnesium hydroxide	YES
Nitric acid HNO <sub>3</sub>	YES	Animal oil	YES
Fresh water H <sub>2</sub> O	YES	Lubricating oil	YES
Ammonia NH <sub>3</sub>	YES	Caustic soda NaOH 5%	YES
Ammonia NH <sub>3</sub>	YES	Caustic soda NaOH 20% E <sup>(1)</sup>	YES
Air	YES	Caustic soda NaOH 50% E <sup>(1)</sup>	YES
Nitrogen N	YES	Caustic soda NaOH 75% E <sup>(1)</sup>	YES
Magnesium bisulphate	YES	Sodium carbonate Na <sub>2</sub> CO <sub>3</sub> 5%	YES
Ethylene glycol	YES	Steam 200° <sup>(2)</sup>	YES
Propylene glycol	YES		

(1) "E" means "ebollizione", i.e. boiling

(2) In versions where temperature cannot reach such value

All data in table 1, if not otherwise specified, is relevant at a temperature of 21°C.

All data have a general meaning and are not valid for all possible working conditions. These data may considerably vary depending upon various conditions, such as: temperature, concentration, fluid speed.

For detailed information, please get in touch with the technical department.

Any use of the valve on explosive, easily inflammable, comburent and poison gases is strictly forbidden.

Any use of the valve on liquids based on: chlorine, fluorine, bromine, iodine and derivative elements is strictly forbidden.

Any deviation from such prohibitions may be issued for special applications, by our technical department, upon written request.

### 4.5 Table 2: $\Delta p$ of SBS/10 2-way valves without bellows

TAB: SBS $\Delta p$ PN16 Rev. 02 del 15/02/2018			$\Delta p$ Valve						Valve definition N°
Control signal in PSI <sup>(1)</sup>			3÷15	6÷18	6÷30	9÷32	3÷9	9÷15	
Control signal in BAR			0,2÷1	0,42÷1,26	0,4÷2,1	0,6÷2,24	0,2÷0,6	0,6÷1,0	
Max control pressure BAR			1	1,26	2,21	2,4	0,8	1,2	
ND	$\varnothing$ seat [mm]	$\varnothing$ eSERV. [mm]	Valve definition letters						
			A	B	C	D	R	S	
15	3	200	16	16	16	16	16	16	1
		275	16	16	16	16	16	16	3
	6	200	16	16	16	16	16	16	4
		275	16	16	16	16	16	16	5
	15	200	15	16	16	16	13	16	6
		275	16	16	16	16	16	16	101
20	200	8	16	16	16	7	16	102	
	275	16	16	16	16	16	16		
20	8	200	16	16	16	16	16	16	7
		275	16	16	16	16	16	16	8
	15	200	15	16	16	16	13	16	9
		275	16	16	16	16	16	16	10
	20	200	8	16	16	16	7	16	13
		275	16	16	16	16	16	16	14
25	15	200	15	16	16	16	13	16	17
		275	16	16	16	16	16	16	18
	20	200	8	16	16	16	7	16	21
		275	16	16	16	16	16	16	22
	26	200	5	10	10	15	5	15	25
		275	13	16	16	16	12	16	26
32	20	200	8	16	16	16	7	16	27
		275	16	16	16	16	16	16	29
	26	200	5	10	10	15	5	15	30
		275	13	16	16	16	12	16	33
	31	200	4	8	8	12	4	12	34
		275	10	16	16	16	10	16	35
40	26	200	5	10	10	15	5	15	37
		275	13	16	16	16	12	16	38
	31	360	16	16	16	16	16	16	39
		200	4	8	8	12	4	12	41
	38	275	10	16	16	16	10	16	42
		360	16	16	16	16	16	16	43
50	31	200	4	8	8	12	4	12	44
		275	10	16	16	16	10	16	45
	38	360	16	16	16	16	16	16	46
		200	2,8	5,5	5,5	8	2,8	8	47
	48	275	7	14	14	16	7	16	48
		360	14	16	16	16	14	16	49
50	31	430	15	16	16	16	15	16	50
		200	4	8	8	12	4	12	51
	38	275	10	16	16	16	10	16	52
		360	16	16	16	16	16	16	53
	48	200	2,8	5,5	5,5	8	2,8	8	54
		275	7	14	14	16	7	16	55
50	31	360	14	16	16	16	14	16	56
		430	15	16	16	16	15	16	57
	48	200	1,6	3,2	3,2	4,5	1,6	4,5	58
		275	4	8	8	10,5	4	10,5	59
50	48	360	8	16	16	16	8	16	60
		430	9,3	16	16	16	9,3	16	61

TAB: SBSΔpPN16 Rev. 02 del 15/02/2018			Δp Valve						Valve definition N°
Control signal in PSI <sup>(1)</sup>			3÷15	6÷18	6÷30	9÷32	3÷9	9÷15	
Control signal in BAR			0,2÷1	0,42÷1,26	0,4÷2,1	0,6÷2,24	0,2÷0,6	0,6÷1,0	
Max control pressure BAR			1	1,26	2,21	2,4	0,8	1,2	
ND	Ø <sub>seat</sub> [mm]	Ø <sub>SERV.</sub> [mm]	Valve definition letters						
			A	B	C	D	R	S	
65	38	200	2,8	5,5	5,5	8	2,8	8	65
		275	7	14	14	16	7	16	66
		360	14	16	16	16	14	16	67
		430	15	16	16	16	15	/	68
	48	200	1,6	3,2	3,2	4,5	1,6	4,5	70
		275	4	8	8	10,5	4	10,5	71
		360	8	16	16	16	8	16	72
		430	9,3	16	16	16	9,3	/	73
	63	200	1	2	2	2,5	1	2,5	75
		275	2,5	5	5	6,5	2,5	6,5	76
		360	5	10	10	13	5	13	77
		430	5,5	11	11	16	5,5	/	78
80	48	200	1,6	3,2	3,2	4,5	1,6	4,5	80
		275	4	8	8	10,5	4	10,5	81
		360	8	16	16	16	8	16	82
		430	9,3	16	16	16	9,3	/	83
	63	200	1	2	2	2,5	1	2,5	85
		275	2,5	5	5	6,5	2,5	6,5	86
		360	5	10	10	13	5	13	87
		430	5,5	11	11	16	5,5	/	88
	78	275	1,5	3	3	4	1,5	4	91
		360	3	6	6	8,5	3	8,5	92
		430	3,5	7	7	10,5	3,5	/	93

Note: Δp Max symbol has been obtained with no air in head.

<sup>(1)</sup> In NO valves, to obtain the same Δp as NC valves, maximum control signal must consist of the addition of two signals; for example, in a NO valve with 3÷15 PSI signal, the maximum control signal must be taken to 18 PSI (3+15) to obtain Δp of similar NC valve.

In 3-way valves, Δp refers to the way closing when air lacks; to obtain the same Δp on the other way follow the same procedure as applied to obtain Δp in NO valve.

#### 4.6 Table 2: $\Delta p$ of SBS/10 2-way valves with bellows

TAB: SBS $\Delta p$ PN16 Rev. 01 del 22/07/2015			$\Delta p$ Valve						Valve definition N°	
Control signal in PSI <sup>(1)</sup>			3÷15	6÷18	6÷30	9÷32	3÷9	9÷15		
Control signal in BAR			0,2÷1	0,42÷1,26	0,4÷2,1	0,6÷2,24	0,2÷0,6	0,6÷1,0		
Max control pressure BAR			1	1,26	2,21	2,4	0,8	1,2		
ND	$\varnothing_{\text{seat}}$ [mm]	$\varnothing_{\text{SERV.}}$ [mm]	Valve definition letters							
			A	B	C	D	R	S		
15	3	200	4,5	8,5	8,5	11	4,5	11	1	
		275	10,5	16	16	16	10,5	16	2	
	6	200	4,5	8,5	8,5	11	4,5	11	3	
		275	10,5	16	16	16	10,5	16	4	
	15	200	4,5	8,5	8,5	11	4,5	11	5	
		275	10,5	16	16	16	10,5	16	6	
		360	16	16	16	16	16	16	103	
	20	8	200	4,5	8,5	8,5	11	4,5	11	7
			275	10,5	16	16	16	10,5	16	8
		15	200	4,5	8,5	8,5	11	4,5	11	9
			275	10,5	16	16	16	10,5	16	10
		20	200	4	8,5	8,5	11	4	11	13
275			10	16	16	16	10	16	14	
25	15	200	4,5	8,5	8,5	11	4,5	11	17	
		275	10,5	16	16	16	10,5	16	18	
		360	16	16	16	16	16	16	23	
	20	200	4	8,5	8,5	11	4	11	21	
		275	10	16	16	16	10	16	22	
		360	16	16	16	16	16	16	23	
	26	200	4	8	8	11	4	11	25	
		275	10	16	16	16	10	16	26	
		360	16	16	16	16	16	16	27	
	32	20	200	4	8,5	8,5	11	4	11	29
			275	10	16	16	16	10	16	30
			360	16	16	16	16	16	16	31
26		200	4	8	8	11	4	11	33	
		275	10	16	16	16	10	16	34	
		360	16	16	16	16	16	16	35	
31		200	3,5	7,5	7,5	10,5	3,5	10,5	37	
		275	9,5	16	16	16	9,5	16	38	
		360	16	16	16	16	16	16	39	
40	26	200	4	8	8	11	4	11	41	
		275	10	16	16	16	10	16	42	
		360	16	16	16	16	16	16	43	
	31	200	3,5	7,5	7,5	10,5	3,5	10,5	45	
		275	9,5	16	16	16	9,5	16	46	
		360	16	16	16	16	16	16	47	
	38	200	2,8	5,5	5,5	8	2,8	8	49	
		275	7	14	14	16	7	16	50	
		360	14	16	16	16	14	16	51	
	50	31	200	3,5	7,5	7,5	10,5	3,5	10,5	53
			275	9,5	16	16	16	9,5	16	54
			360	16	16	16	16	16	16	55
38		200	2,8	5,5	5,5	8	2,8	8	57	
		275	7	14	14	16	7	16	58	
		360	14	16	16	16	14	16	59	
		430	15	16	16	16	15	16	60	
48		200	1,6	3,2	3,2	4,5	1,6	4,5	61	
		275	4	8	8	10,5	4	10,5	62	
		360	8	16	16	16	8	16	63	
			430	9,3	16	16	16	9,3	64	

TAB: SBSΔpPN16 Rev. 01 del 22/07/2015			Δp Valve						Valve definition N°
Control signal in PSI <sup>(1)</sup>			3÷15	6÷18	6÷30	9÷32	3÷9	9÷15	
Control signal in BAR			0,2÷1	0,42÷1,26	0,4÷2,1	0,6÷2,24	0,2÷0,6	0,6÷1,0	
Max control pressure BAR			1	1,26	2,21	2,4	0,8	1,2	
ND	Ø <sub>seat</sub> [mm]	Ø <sub>e</sub> SERV. [mm]	Valve definition letters						
			A	B	C	D	R	S	
65	38	200	2,8	5,5	5,5	8	2,8	8	65
		275	7	14	14	16	7	16	66
		360	14	16	16	16	14	16	67
		430	15	16	16	16	15	/	68
	48	200	1,6	3,2	3,2	4,5	1,6	4,5	70
		275	4	8	8	10,5	4	10,5	71
		360	8	16	16	16	8	16	72
		430	9,3	16	16	16	9,3	/	73
	63	200	1	2	2	2,5	1	2,5	75
		275	2,5	5	5	6,5	2,5	6,5	76
		360	5	10	10	13	5	13	77
		430	5,5	10,5	10,5	16	5,5	/	78
80	48	200	1,6	3,2	3,2	4,5	1,6	4,5	80
		275	4	8	8	10,5	4	10,5	81
		360	8	16	16	16	8	16	82
		430	9,3	16	16	16	9,3	/	83
	63	200	1	2	2	2,5	1	2,5	85
		275	2,5	5	5	6,5	2,5	6,5	86
		360	5	10	10	13	5	13	87
		430	5,5	10,5	10,5	16	5,5	/	88
	78	275	1,5	3	3	4	1,5	4	91
		360	3	6	6	8,5	3	8,5	92
		430	3,5	7	7	10,5	3,5	/	93

Note: Δp Max symbol has been obtained with no air in head.

<sup>(1)</sup> In NO valves, to obtain the same Δp as NC valves, maximum control signal must consist of the addition of two signals; for example, in a NO valve with 3÷15 PSI signal, the maximum control signal must be taken to 18 PSI (3+15) to obtain Δp of similar NC valve.

In 3-way valves, Δp refers to the way closing when air lacks; to obtain the same Δp on the other way follow the same procedure as applied to obtain Δp in NO valve.

**4.7 Table 4: Kv of SBS/10 2-way valves.**

ND	Ø seat [mm]	Stroke [mm]	Kvs <sup>(1)</sup>		CV	
			Linear shutter	Equipcentage shutter	Linear shutter	Equipcentage shutter
15	3	15	UT	UT	UT	UT
		15	UT	UT	UT	UT
	6	15	4,3	4,5	5	5,2
		15	5	5	5,8	5,8
20	8	15	UT	UT	UT	UT
		15	6	4,8	7	5,6
	20	8	7,5	9,3	8,7	
25	15	15	5,4	5,3	6,3	6,2
		15	9,3	9,1	10,8	10,6
	26	11,8	11,3	13,7	13,1	
32	20	15	9,6	9,5	11,2	11
		20	10,2	10,5	11,8	12,2
	26	15	14,5	13,5	16,9	15,7
		20	14,9	15,4	17,3	17,9
	31	20	20	15,2	23,3	17,7
		20	18,9	18,9	22	22

ND	Ø seat [mm]	Stroke [mm]	Kvs <sup>(1)</sup>		CV	
			Linear shutter	Equipcentage shutter	Linear shutter	Equipcentage shutter
40	26	15	16,5	15,6	19,2	18,4
		20	18,1	18,5	21,1	21,4
	31	15	21,9	19	25,5	22,1
		20	24,5	24,7	28,5	28,7
	38	15	26	22,3	30,2	25,9
		20	29,3	28,3	34,1	32,9
50	31	15	22,1	19,1	25,7	22,2
		20	25,1	25,1	29,1	29,1
	38	15	27,6	23	32,1	26,7
		20	33,8	32	39,3	37,2
	48	15	38,4	34,6	44,7	40,2
		20	42,4	44,7	49,3	52
65	38	15	27,9	24	32,4	27,9
		20	34,1	33	39,7	38,4
	48	15	45,5	42	53,5	49,4
		20	56,9	55	66,9	64,7
	63	15	61	36,3	71,0	42,3
		20	74,8	63,1	87,1	73,5
80	48	15	43,2	41,6	50,3	48,4
		20	55,5	53,5	64,6	62,3
	63	15	62,2	37	72,4	43,1
		20	76,6	62,2	89,2	72,4
	78	15	61,9	43,16	72,1	50,3
		20	85,8	77,9	99,9	90,7

<sup>(1)</sup> The kv has been calculated using the FLOWSimulation fluid dynamics program in accordance with the UNI EN 1267:2001 standard and refers to a 2-way valve

For valves with bellows consider only stroke 15

UT: contact our technical department.



---

## 4.8 Safety Notes

- The valve body, under maximum usage temperature conditions depending on the plant, can reach T=200°C (GJL-250) T=300°C (GJS-500-7). It is up to the engineer to provide the system with the necessary safety guards and/or warning signals with the purpose to remove/indicate the risk of any burns to the user (if any).
- During any operation on the valve, the fluid shall not be present inside the piping or the valve.

## 4.9 Overall dimensions of SBS/10 valves

### 4.9.1 SBS/10 2-way cast iron

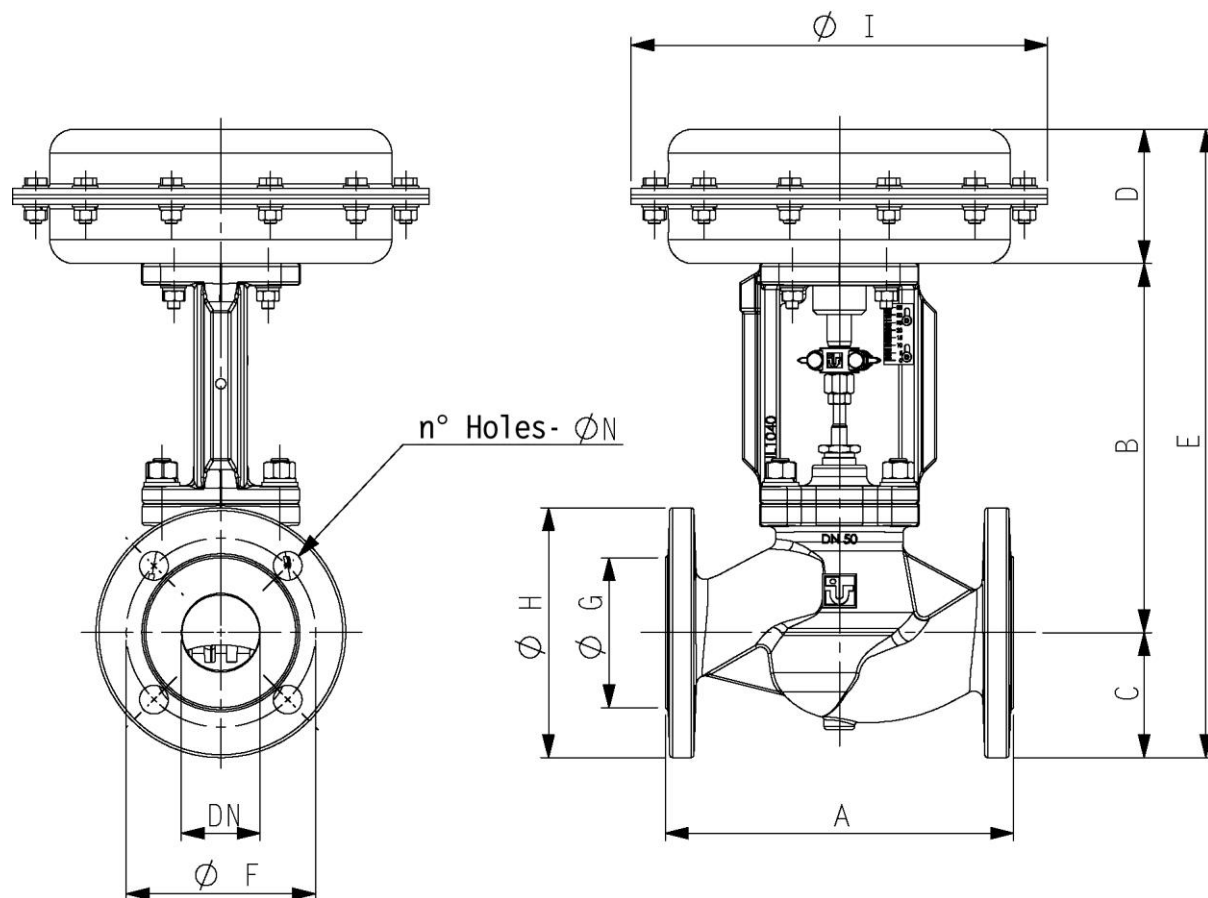

Drawing No. 090268 Rev.:00

DN	A	B	C	D			E			$\varnothing F$	$\varnothing G$	$\varnothing H$	$\varnothing I$	$\varnothing N$	No. of holes
				$\varnothing$ servo control			$\varnothing$ servo control								
				200	275 360	430	200	275 360	430						
15	130	225	47.5	77	88,5	123	349,5	361	395,5	65	45	95	According to sealing $\Delta p$ required (200-275-360-430)	14	4
20	150	225	52.5	77	88,5	123	354,5	366	400,5	75	58	105		14	4
25	160	225	57,5	77	88,5	123	359,5	371	405,5	85	65	115		14	4
32	180	248	70	77	88,5	123	395	406,5	441	100	76	140		19	4
40	200	245,5	75	77	88,5	123	397,5	409	443,5	110	84	150		19	4
50	230	244	82,5	77	88,5	123	403,5	415	449,5	125	99	165		19	4
65	290	299	92,5	77	88,5	123	468,5	480	514,5	145	118	185		19	4
80	310	298	100	77	88,5	123	475	486,5	521	160	132	200		19	8

Dimensions are in millimeters

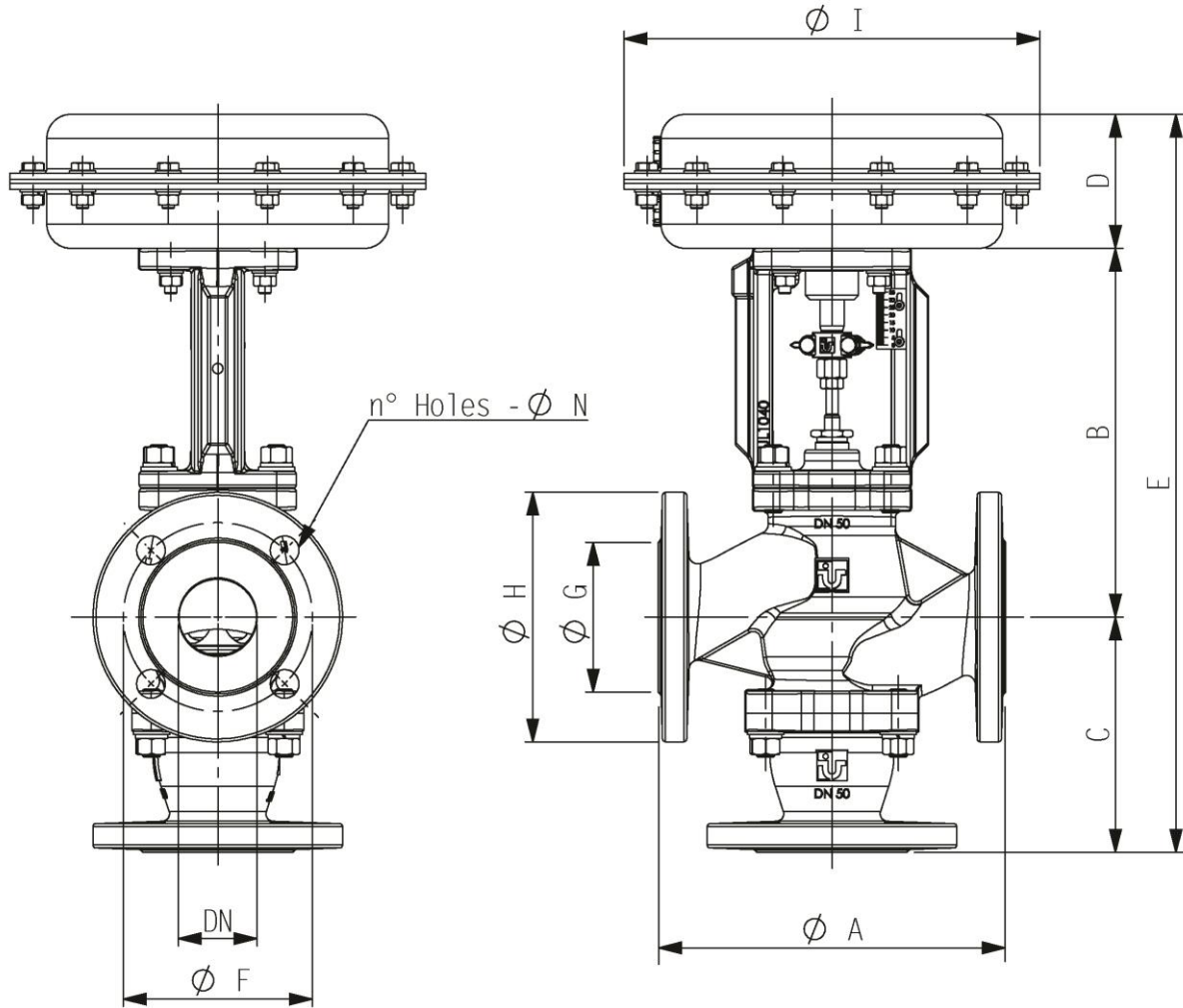
**4.9.2 SBS/10 3-way cast iron**

Drawing No. 090269 Rev.:00

DN	A	B	C	D			E			Ø F	Ø G	Ø H	Ø I	Ø N	No. of holes
				Ø servo control			Ø servo control								
				200	275 360	430	200	275 360	430						
15	130	225	110,5	77	88,5	123	412,5	424	458,5	65	45	95	According to sealing $\Delta p$ required (200-275-360-430)	14	4
20	150	225	110,5	77	88,5	123	412,5	424	458,5	75	58	105		14	4
25	160	225	125	77	88,5	123	427	438,5	473	85	65	115		14	4
32	180	248	143	77	88,5	123	468	479,5	514	100	76	140		19	4
40	200	245,5	143,5	77	88,5	123	466	477,5	512	110	84	150		19	4
50	230	244	160,5	77	88,5	123	481,5	493	527,5	125	99	165		19	4
65	290	299	236,5	77	88,5	123	612,5	624	658,5	145	118	185		19	4
80	310	298	238,5	77	88,5	123	613,5	625	659,5	160	132	200		19	8

Dimensions are in millimeters

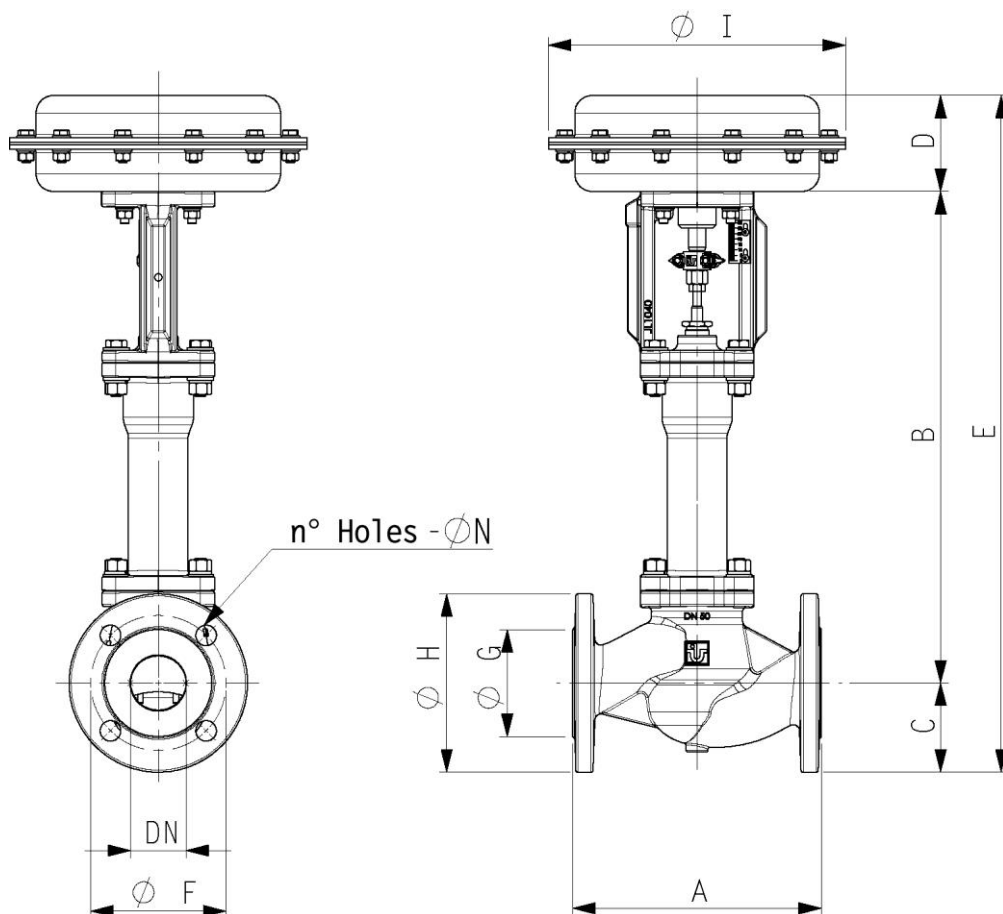
**4.9.3 SBS/10 2-way cast iron with safety bellows**

Drawing No. 090927 Rev:00

DN	A	B	C	D			E			Ø F	Ø G	Ø H	Ø I	Ø N	No. of holes
				Ø servo control			Ø servo control								
				200	275 360	430	200	275 360	430						
15	130	438	47,5	77	88,5	123	562,5	574	608,5	65	45	95	According to sealing Δp required (200-275-360-430)	14	4
20	150	438	52,5	77	88,5	123	567,5	579	613,5	75	58	105		14	4
25	160	438	57,5	77	88,5	123	572,5	584	618,5	85	65	115		14	4
32	180	459	70	77	88,5	123	606	617,5	652	100	76	140		19	4
40	200	456,5	75	77	88,5	123	608,5	620	654,5	110	84	150		19	4
50	230	455	82,5	77	88,5	123	614,5	626	660,5	125	99	165		19	4
65	290	510	92,5	77	88,5	123	679,5	691	725,5	145	118	185		19	4
80	310	509	100	77	88,5	123	686	697,5	732	160	132	200		19	8

Dimensions are in millimeters

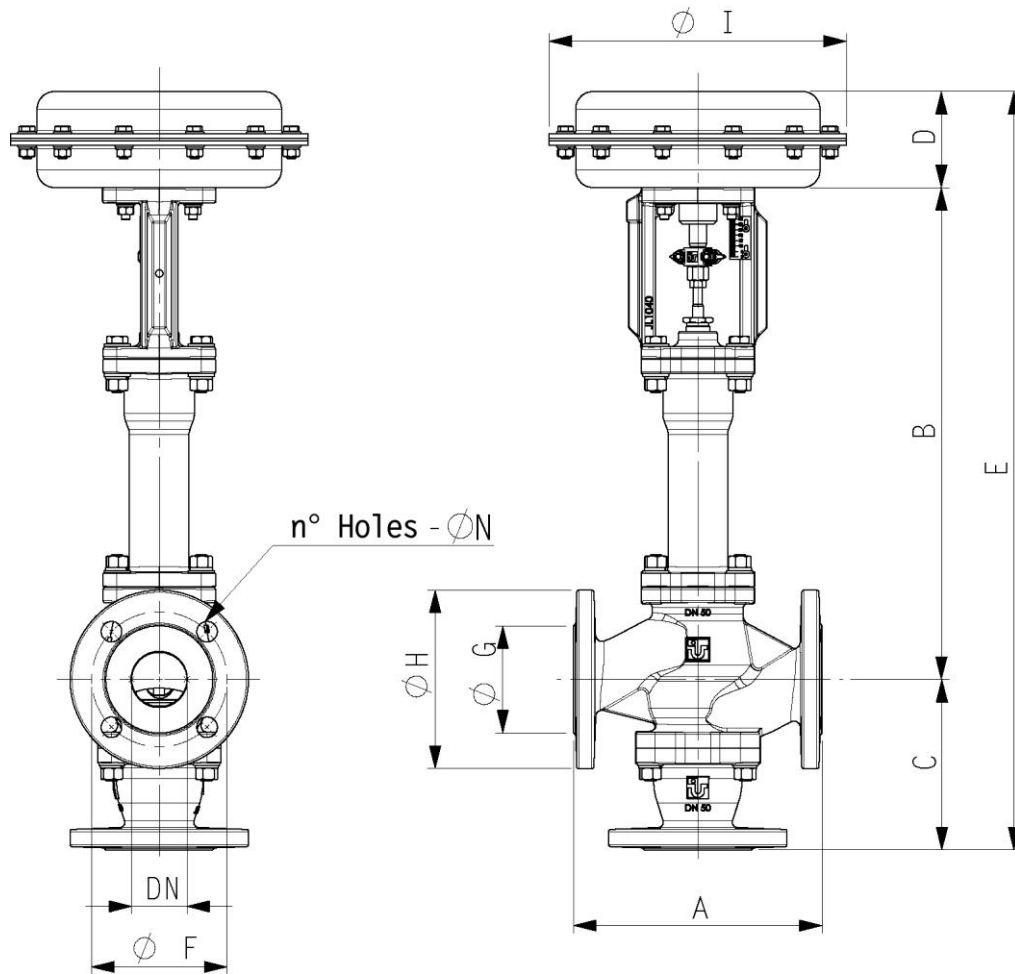
**4.9.4 SBS/10 3-way cast iron with safety bellows**

Drawing No. 090928 Rev.:00

DN	A	B	C	D			E			Ø F	Ø G	Ø H	Ø I	Ø N	No. of holes
				Ø servo control			Ø servo control								
				200	275 360	430	200	275 360	430						
15	130	438	110,5	77	88,5	123	625,5	637	671,5	65	45	95	According to sealing Δp required (200-275-360-430)	14	4
20	150	438	110,5	77	88,5	123	625,5	637	671,5	75	58	105		14	4
25	160	438	125	77	88,5	123	640	651,5	686	85	65	115		14	4
32	180	459	143	77	88,5	123	679	690,5	725	100	76	140		19	4
40	200	456,5	143,5	77	88,5	123	677	688,5	723	110	84	150		19	4
50	230	455	160,5	77	88,5	123	692,5	704	738,5	125	99	165		19	4
65	290	510	236,5	77	88,5	123	823,5	835	869,5	145	118	185		19	4
80	310	509	238,5	77	88,5	123	824,5	836	870,5	160	132	200		19	8

Dimensions are in millimeters

## 5 SBS/10 tags description

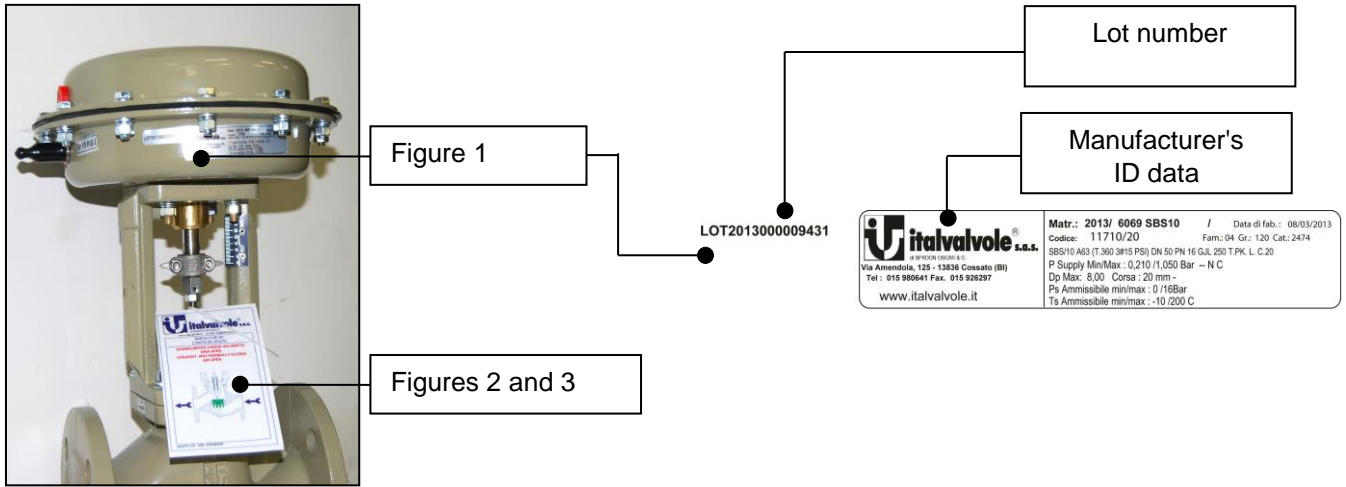

Fig.1 : Technical data of the valves

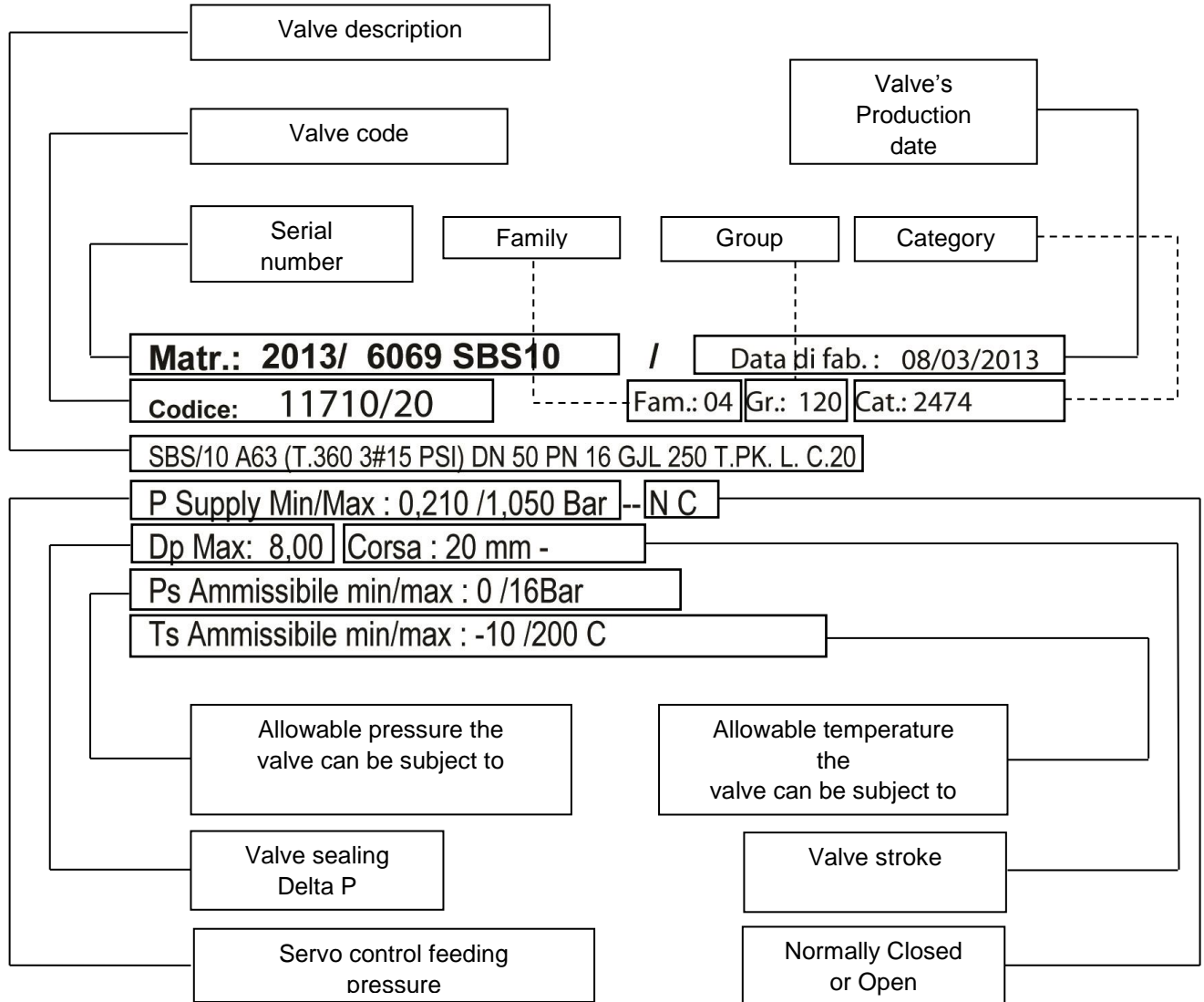



Fig. 2: Front - Proper installation procedure for optimum operation of the SBS/10 2 ways, 3M valves.

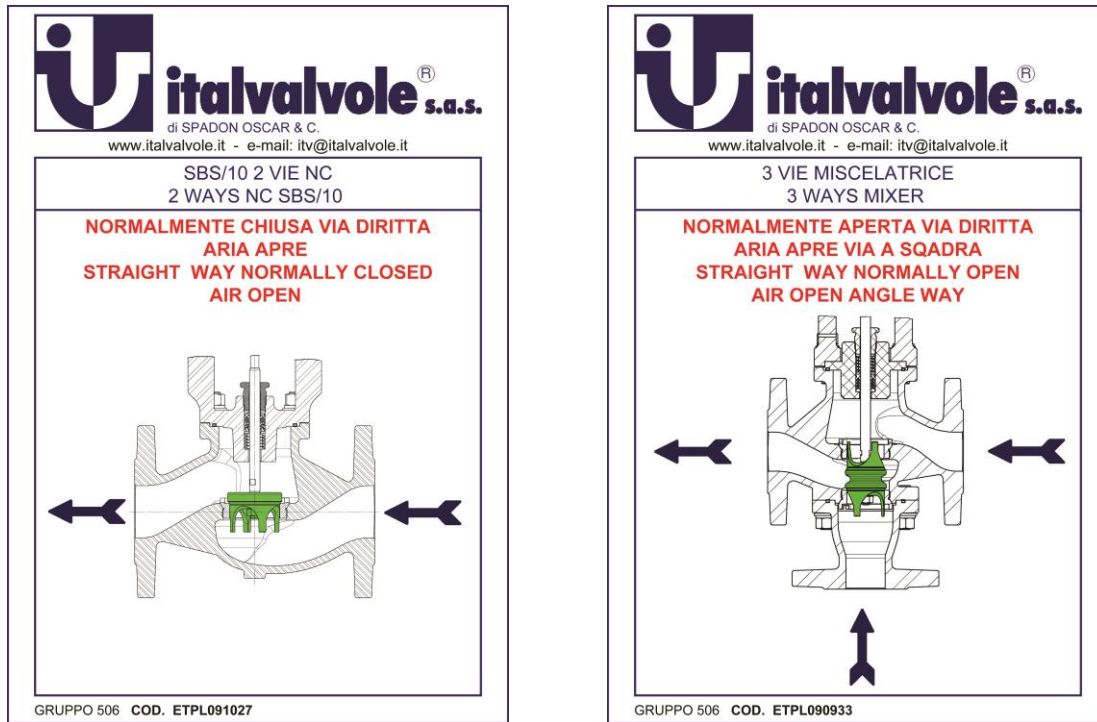
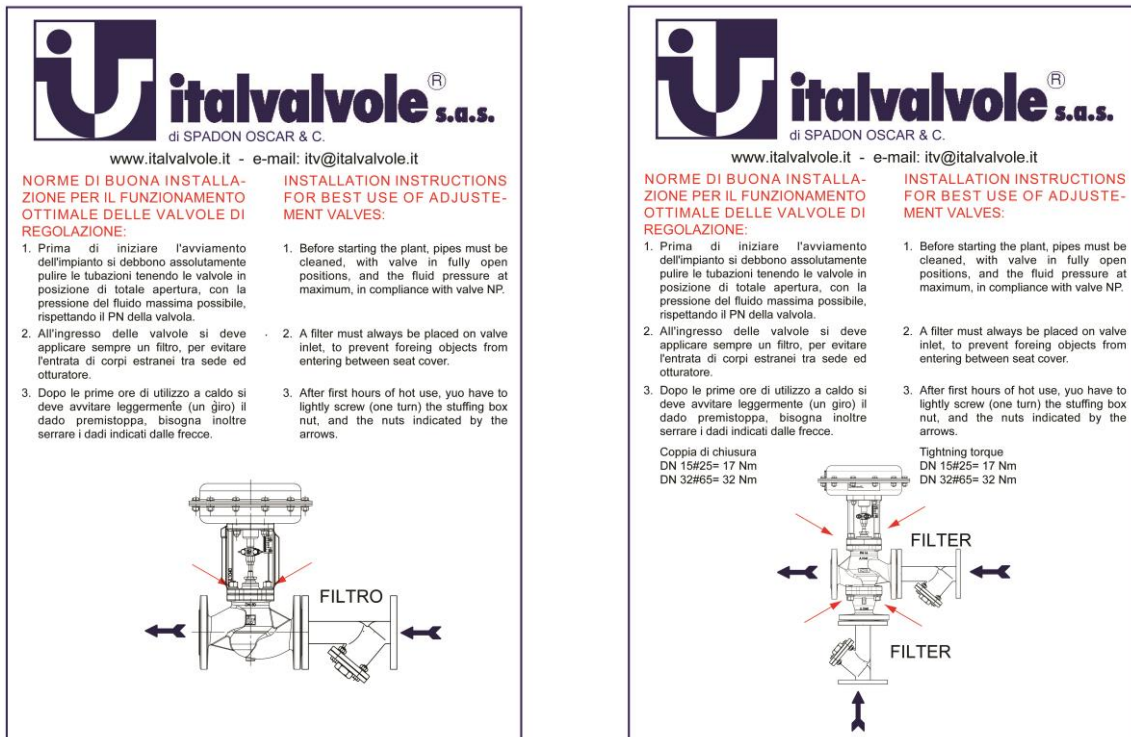

Fig. 3: Back - Proper installation procedure for optimum operation of the SBS/10 2 ways, 3M valves.



## 6 Storage, Assembly, Check And Maintenance

### 6.1 Transport, Storage and Handling

SBS/10 valves, during transport and assembly, must be handled very carefully. Shocks as well as anomalous stresses must be avoided (do not lift the valve by servo control).

Avoid shocks and tampering to any accessories the valve may be equipped with (positioning devices, transducers, FRLM units, etc.).

Valves are delivered with dust-proof protections on all connections and these protections must not be removed until they are installed.

Valves shall be stored in areas which are not exposed to the sunshine, so as to prevent inner gaskets and membrane from getting dry and old before time.

Storage temperature shall be between 0°C and + 50°C.

Avoid any shock to servo control as they could provoke misalignments and affect valve proper operation.

Comply with specifications on labels.

### 6.2 Assembly Instructions

#### 6.2.1 General information

Valve installation on the system shall be carried out only by personnel qualified in in hydraulics and pneumatics, provided with all the equipment normally used in the industrial hydraulic and pneumatic plant engineering. The personnel shall always wear proper accident prevention garments, taking particular care to protect face, eyes and hands.

The valve must never be disassembled or modified. Otherwise, warranty is voided.

**Please note. Attention: compressed springs are included inside the servo control.**

Before assembly, dust-proof protections shall be removed from the valve body.

The threaded cap on unused air connection must not be removed to prevent dust or foreign matters from entering the servo control.

Compressed air shall be industrial air, with a pressure between servo control useful values and anyway never exceeding 2.5 bars, with supply pipes made of nylon or copper and inner diameter = 4 mm. Air connections on valve must be 1/8" GAS (head Ø 200) or 1/4" (head Ø 275, Ø 360, Ø 430) male threaded couplings.

#### 6.2.2 Installation of valve on the plant

Comply with specifications on labels and valve body fusion

Before assembly, ensure that no dirt has penetrate the valve body; in case of doubt, strongly blow with compressed air.

It is recommended to install a protection filter on pipe upstream the valve.

The commonest recommended installation provides for vertical assembly of the valve, with servo control on top. Tilted or horizontal assemblies are only accepted for dimensional reasons only.

To ensure a continuous operation of the plant also during valve maintenance, it is recommended to provide for a proper bypass with relevant on-off and manual control valves.

**WARNINGS:** when installing a valve, provide for a minimum space necessary to disassemble the pneumatic servo control and internal organs during maintenance operations.

**Please note. Attention: compressed springs are included inside the servo control.**

Be very careful when assembling the pipe valve, ensure it is installed in compliance with specifications on body fusion, in the same direction as pipe flow. Perform a uniform and crossed tightening of flange bolts to evenly press seals and prevent any harmful tensions from arising on the valve body.

It is recommended to use joints between plant pipes and valve connections, suitable to discharge any tensions possibly damaging the valve itself.

After installation, with pneumatic valve in maximum opening position, carefully clean the line with suitably pressurized fluid to remove any foreign bodies, welding slags and debris possibly damaging valve sealing surfaces.

Connect the pneumatic signal out of the pilot regulator or remote control panel to the relevant threaded coupling of servo control.

## 6.3 Installation diagrams

### 6.3.1 Installation of SBS/10 2-way valves

Nut tightening torque:  
DN 15#25 [M10 nuts] 17 Nm  
DN 32#80 [M12 nuts] 32 Nm

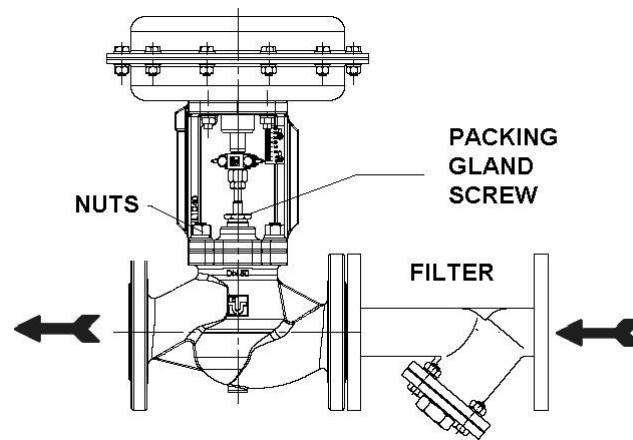

Figure 1

When installing SBS/10 2-way valves, a filter must be assembled on valve inlet to collect any impurity possibly damaging sealing. Assemble SBS/10 2-way valve as shown in figure 1, following the direction arrows on the valve. After the first hours of hot usage, slightly tighten the packing gland screw (1 revolution) and check tightening of nuts specified.

### 6.3.2 Installation of SBS/10 3-way deviator valves

Nut tightening torque:  
DN 15#25 [M10 nuts] 17 Nm  
DN 32#80 [M12 nuts] 32 Nm

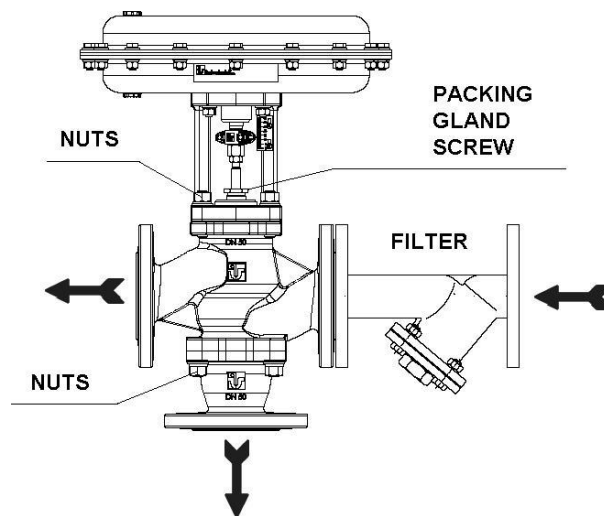
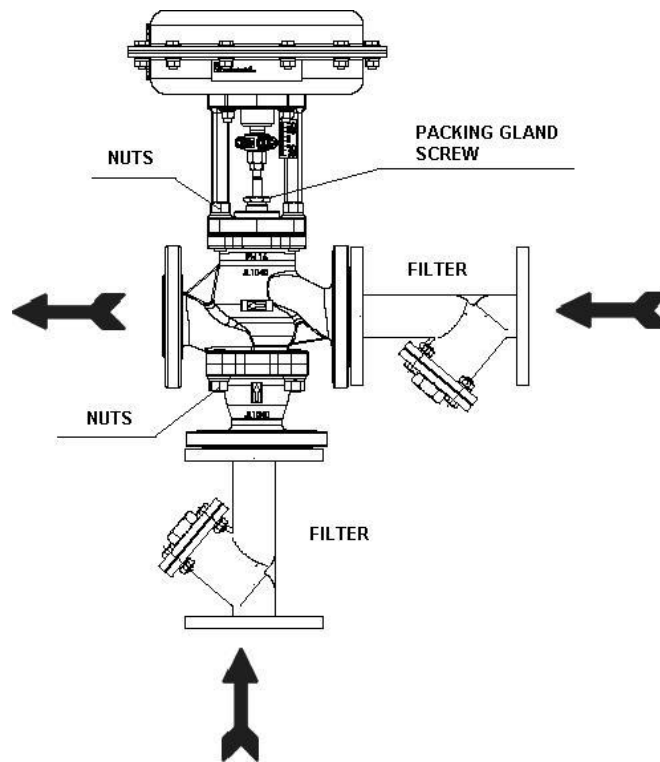

Figure 2

When installing SBS/10 3-way deviator valves, a filter must be assembled on valve inlet to collect any impurity possibly damaging sealing. Assemble SBS/10 3-way deviator valve as shown in figure 2, following the direction arrows on the valve. After the first hours of hot usage, slightly tighten the packing gland screw (1 revolution) and check tightening of nuts specified on diagram.

### 6.3.3 Installation of SBS/10 3-way mixer valves

Nut tightening torque:  
DN 15#25 [M10 nuts] 17 Nm  
DN 32#80 [M12 nuts] 32 Nm



**Figure 3**

When installing SBS/10 3-way mixer valves, filters must be assembled on two valve inlets to collect any impurity possibly damaging sealing. Assemble SBS/10 3-way mixer valve as shown in figure 3, following the direction arrows on the valve. After the first hours of hot usage, slightly tighten the packing gland screw (1 revolution) and check tightening of nuts specified.

## 6.4 Operation Test

Before starting up the system and after any repair or overhaul, the following operation test shall be carried out:

### On valves with normally closed NC servo control:

- 1) Send the fluid inside the valve under shutter at the operating pressure (check that it is always lower than the maximum allowable pressure of the valve as shown on specifications plate).
- 2) Insert into servo control the minimum value of control signal shown on specifications plate (the valve should start opening, datum available on stroke plate).
- 3) Insert into servo control the maximum value of control signal shown on specifications plate (the valve should be fully open, datum available on stroke plate).
- 4) Switch off air from the servo control.
- 5) Repeat this operation 5 times.
- 6) Check, with air off, that there is no leak from the valve.
- 7) Check, with air on, that there is no air leak from the servo control.

### On valves with normally open NO servo control:

- 1) Send the fluid inside the valve under shutter at the operating pressure (check that it is always lower than the maximum allowable pressure of the valve).
- 2) Insert into servo control the minimum value of control signal shown on specifications plate (the valve should start closing, datum available on stroke plate).
- 3) Insert into servo control the maximum value of control signal shown on specifications plate (the valve should close, datum available on stroke plate).
- 4) Repeat this operation 5 times.
- 5) Check, with air on, that there is no leak from the valve (with pressure value equal to the addition of two signals  $3/15 = 18$  PSI).
- 6) Check, with air on, that there is no air leak from the servo control.

## 6.5 Troubleshooting

Troubleshooting operations shall be always carried out by qualified personnel only, adequately equipped for the hydraulic and pneumatic operations and provided with the proper safety clothing, paying particular attention to the protection of face, eyes and hands.

Please note: to properly operate the valve, the stem must freely move with no friction when air pressure on diaphragm changes.

Valve serial number is printed on the label located on servo control. Please refer to the serial number for spare part request and correspondence.

Whenever operations are to be carried out on valves, remove the fluid completely. The valve body shall be completely empty.

### 6.5.1 Fluid passage with valve closed

If the valve is in closed position, ensure that no foreign body exists between shutter and seat and the surface contact is not damaged.

For effective damages affecting the seat, the shutter seat must be replaced (for valve disassembly see instructions below).

### 6.5.2 Diaphragm (membrane)

If the rubber membrane inside the servo control breaks, the valve cannot perform a complete stroke.

Replace the membrane when it is broken or has lost elasticity (see proper procedure below).

In all cases of irregular operation during adjustment, immediately ensure that pneumatic connections between pilot regulator and valve and the relevant fittings show no signs of air leaks.

Also ensure that regulator is properly calibrated (activity direction, proportionate band, automatic restoration).

## 6.6 Scheduled Maintenance

Scheduled maintenance operations shall be carried out independently of the ones due to possible failures, which always require an immediate intervention.

The time interval between one maintenance operation and the following shall be included in the lower time interval between the one corresponding to 500,000 cycles and three years. It consists of a complete disassembly of the valve, replacement of all the gaskets and a complete cleaning of all other components. For disassembly and re-assembly operations, make reference to the relevant paragraphs of this manual.

After first operating period, it is recommended to check the packing gland, as it requires special care. During the first operating hours, check no leaks have occurred, otherwise act very carefully on the relevant tightening nut to eliminate them, by rotating once of 1/4 revolution maximum on each packing gland made of teflon-graphite.

It is also recommended not to excessively tighten the nut, to prevent excessive increase of frictions on the stem which could block the valve or generate bad operation. Should further lacks persist in spite of tightening, fully replace the packing gland.

## 6.7 Disassembly and assembly instructions for SBS/10 ND 15#50 2-way NC valve

For disassembly and assembly instructions for SBS/10 ND 15#50 2-way NC valve refer to Drw. No. 090264 attached hereby.

Assembly and disassembly operations shall be carried out only personnel qualified in in hydraulics and pneumatics, provided with all the necessary work and safety equipment. Before carrying out any operation on systems and valves, get acquainted with operating temperatures and pressures and any other particular conditions, and take the relevant safety measures.

Whenever operations are to be carried out on valves, remove the fluid completely.

**NOTE: Read the procedures thoroughly before starting any operation.**

### 6.7.1 Disassembly

- 1) Enter an air signal into the servo control equal to the maximum value provided for by this signal: **Attention! Servo control shaft shall move upwards**
- 2) Unscrew the nuts (35), extract the spring washers (36) and the flat washers (37).
- 3) Separate the servo control, the frame with intermediate body and the shutter from the valve body.
- 4) Unscrew the nuts (32), extract the washers (31) and the screws (29), separate the junction clamps (30).
- 5) Untighten adjustment nut (11) and nut (12) carefully making their position.
- 6) Remove the shutter (17) from the frame with intermediate body (33).
- 7) Remove air from servo control, unscrew the nuts (28), extract the spring washers (27) and the flat washers (26).
- 8) Separate the frame with intermediate body from servo control.
- 9) Untighten the packing gland screw (13). **Caution! The packing gland screw (13) keeps the packing gland spring (17) compressed; maximum care shall then be taken to prevent the inner components of frame with intermediate body from coming out suddenly when the packing gland screw (13) is no more kept by the thread.**
- 10) Extract from frame with the intermediate body (33), the first packing gland washer (14), the packing gland (14), the second packing gland washer (15) and the packing gland spring (17).
- 11) Remove the body seal (16) from the frame with intermediate body (33).
- 12) Disassemble the servo control following the procedure described in paragraph 6.27.1.
- 13) Disassemble the shutter following the procedure described in paragraph 6.29.1.
- 14) Now the valve has been completely disassembled, so that the required components can be replaced.

### 6.7.2 Reassembly

- 1) Reassemble the servo control following the procedure described in paragraph 6.27.2.
- 2) Reassemble the shutter following the procedure described in paragraph 6.29.2.
- 3) Insert in the frame with the intermediate body the packing gland spring (17), the first packing gland washer (14), the packing gland (15), the second packing gland washer (14).
- 4) Tighten the packing gland screw (13) by two revolutions. **Caution! The packing gland screw keeps the packing gland spring compressed; maximum care shall then be taken to prevent the parts located on the spring from coming out suddenly during the assembly operations.**
- 5) Insert the shutter (18) into the frame with intermediate body (33), carefully greasing it with silicone grease.
- 6) Insert the body gasket (16) into the frame seat (33).
- 7) Insert the previously-assembled frame (33) onto stud-bolts and into the valve body seat (38).
- 8) Insert the spring washers (37) and the elastic washers (36) on the stud-bolts and torque tighten the nuts (35) according to table 6 on page 84.
- 9) Tighten packing gland screw (13) until it is projected by  $\approx 13$  mm from the upper level of intermediate body.
- 10) Fully tighten on the shutter stem (18) the nut (12) and the adjustment nut (11).
- 11) Place the previously-assembled servo control on the frame with intermediate body (33).
- 12) Insert the flat washers (26) and the elastic washers (27) on the lower head stud-bolts and torque tighten the nuts (28) according to table 6 on page 84.
- 13) Enter air into the servo control equal to the maximum value provided for by this signal: **Attention! Servo control stem shall move upwards in its stroke.**
- 14) Place precharge adjustment nut (11) in the position kept before valve disassembly to obtain the same calibration, then fasten by nut (12).
- 15) Push shutter in contact with seat, then extract air from servo control: **Attention! Servo control stem shall move downwards until in contact with adjustment nut (11).**
- 16) Join precharge adjustment nut (11) and servo control shaft (10) with junction clamps (30), insert screws (29) and insert washers (31) on them, then tighten the nuts (32).



**Sectional view of SBS/10 ND 15#50 2-way NC valve**

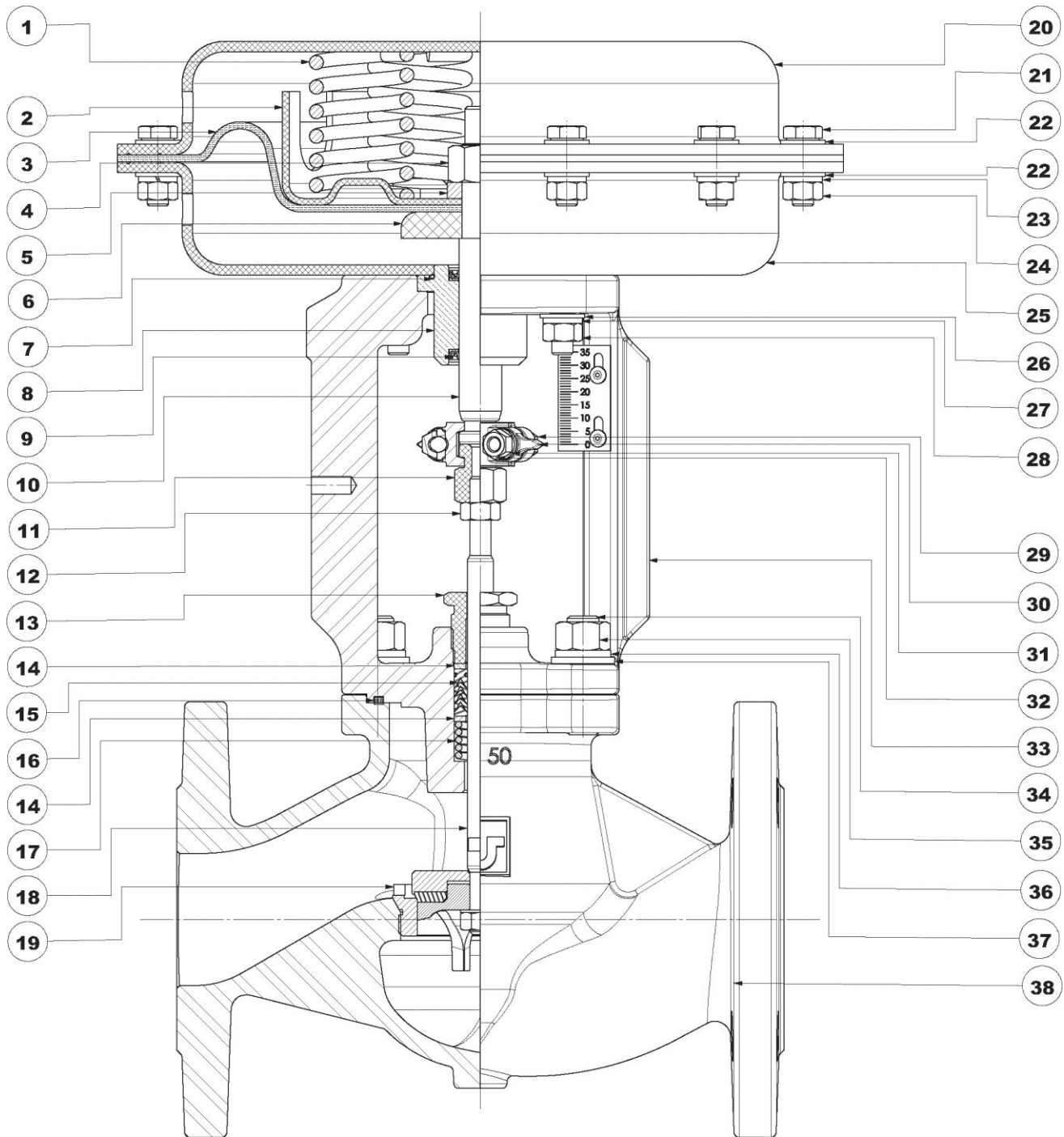

Drawing No. 090264 Rev.:00

## 6.8 Disassembly and assembly instructions for SBS/10 ND 65#80 2-way NC valve

For disassembly and assembly instructions for SBS/10 ND 65#80 2-way NC valve refer to Drw. No. 100659 attached hereby.

Assembly and disassembly operations shall be carried out only personnel qualified in in hydraulics and pneumatics, provided with all the necessary work and safety equipment. Before carrying out any operation on systems and valves, get acquainted with operating temperatures and pressures and any other particular conditions, and take the relevant safety measures.

Whenever operations are to be carried out on valves, remove the fluid completely.

**NOTE: Read the procedures thoroughly before starting any operation.**

### 6.8.1 Disassembly

- 1) Unscrew the nuts (32), extract the washers (31) and the screws (29), separate the junction clamps (30).
- 2) Enter an air signal into the servo control equal to the maximum value provided for by this signal: **Attention! Servo control shaft shall move upwards**
- 3) Unscrew the nuts (35), extract the spring washers (36) and the flat washers (37).
- 4) Separate the servo control, the mounting valve from the valve body.
- 5) Untighten adjustment nut (11) and nut (12) carefully making their position.
- 6) Remove the intermediate body (51) with shutter (18).
- 7) Remove the body gasket (50) from the intermediate body (51).
- 8) Remove the shutter from the intermediate body
- 9) Remove air from servo control, unscrew the nuts (28), extract the spring washers (27) and the flat washers (26).
- 10) Separate the mounting from servo control.
- 11) Untighten the packing gland screw (13). **Caution! The packing gland screw (13) keeps the packing gland spring (17) compressed; maximum care shall then be taken to prevent the inner components of frame with intermediate body from coming out suddenly when the packing gland screw (13) is no more kept by the thread.**
- 12) Extract from the intermediate body (33), the first packing gland washer (14), the packing gland (14), the second packing gland washer (15) and the packing gland spring (17).
- 13) Disassemble the servo control following the procedure described in paragraph 6.27.1.
- 14) Now the valve has been completely disassembled, so that the required components can be replaced.

### 6.8.2 Reassembly

- 1) Reassemble the servo control following the procedure described in paragraph 6.27.2.
- 2) Insert in the intermediate body (51) the packing gland spring (17), the first packing gland washer (14), the packing gland (15), the second packing gland washer (14).
- 3) Tighten the packing gland screw (13) by two revolutions. **Caution! The packing gland screw keeps the packing gland spring compressed; maximum care shall then be taken to prevent the parts located on the spring from coming out suddenly during the assembly operations.**
- 4) Insert the shutter (18) into the intermediate body (51), carefully greasing it with silicone grease.
- 5) Insert the body gasket (50) into the intermediate body seat (51).
- 6) Insert the previously-assembled intermediate body (51) onto the valve body seat (38).
- 7) Place precharge adjustment nut (11) in the position kept before valve disassembly to obtain the same calibration, then fasten by nut (12).
- 8) Place the previously-assembled servo control on the mounting (57).
- 9) Insert the flat washers (26) and the elastic washers (27) on the lower head stud-bolts and torque tighten the nuts (28) according to table 6 on page 84.
- 10) Enter air into the servo control equal to the maximum value provided for by this signal: **Attention! Servo control stem shall move upwards in its stroke.**
- 11) Place the servo control with mounting on the valve body (38).
- 12) Insert the spring washers (37) and the elastic washers (36) on the stud-bolts and torque tighten the nuts (35) according to table 6 on page 84.
- 13) Tighten packing gland screw (13) until it is projected by  $\approx 13$  mm from the upper level of intermediate body.
- 14) Push shutter in contact with seat, then extract air from servo control: **Attention! Servo control stem shall move downwards until in contact with adjustment nut (11).**
- 15) Join precharge adjustment nut (11) and servo control shaft (10) with junction clamps (30), insert screws (29) and insert washers (31) on them, then tighten the nuts (32).

**Sectional view of SBS/10 ND 65#80 2-way NC valve**

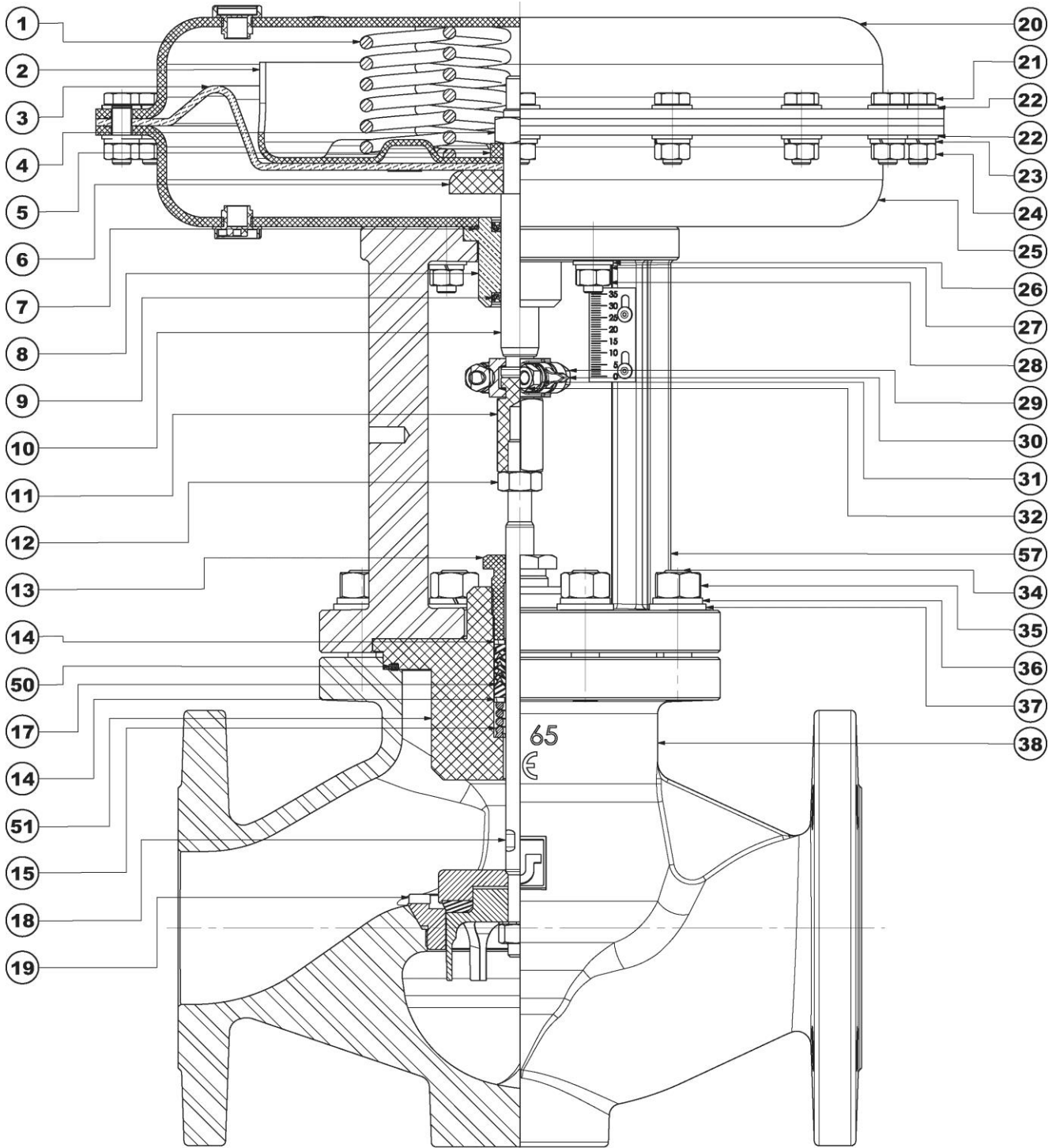

Drawing No. 100659 Rev.:01

## 6.9 Disassembly and assembly instructions for SBS/10 ND 15#50 2-way NO valve

For disassembly and assembly instructions for SBS/10 ND 15#50 2-way NO valve refer to Drw. No. 090265 attached hereby.

Assembly and disassembly operations shall be carried out only personnel qualified in in hydraulics and pneumatics, provided with all the necessary work and safety equipment. Before carrying out any operation on systems and valves, get acquainted with operating temperatures and pressures and any other particular conditions, and take the relevant safety measures.

Whenever operations are to be carried out on valves, remove the fluid completely.

**NOTE: Read the procedures thoroughly before starting any operation.**

### 6.9.1 Disassembly

- 1) Unscrew the nuts (35), extract the spring washers (36) and the flat washers (37).
- 2) Separate the servo control, the frame with intermediate body and the shutter from the valve body.
- 3) Unscrew the nuts (32), extract the washers (31) and the screws (29), separate the junction clamps (30).
- 4) Untighten adjustment nut (11) and nut (12) carefully making their position.
- 5) Remove the shutter (17) from the frame with intermediate body (33).
- 6) Unscrew the nuts (28), extract the spring washers (27) and the flat washers (26).
- 7) Separate the frame with intermediate body from servo control.
- 8) Untighten the packing gland screw (13). **Caution! The packing gland screw (13) keeps the packing gland spring (17) compressed; maximum care shall then be taken to prevent the inner components of frame with intermediate body from coming out suddenly when the packing gland screw (13) is no more kept by the thread.**
- 9) Extract from frame with the intermediate body (33), the first packing gland washer (14), the packing gland (14), the second packing gland washer (15) and the packing gland spring (17).
- 10) Remove the body seal (16) from the frame with intermediate body (33).
- 11) Disassemble the servo control following the procedure described in paragraph 6.28.1.
- 12) Disassemble the shutter following the procedure described in paragraph 6.29.1.
- 13) Now the valve has been completely disassembled, so that the required components can be replaced.

### 6.9.2 Reassembly

- 1) Reassemble the servo control following the procedure described in paragraph 6.28.2.
- 2) Reassemble the shutter following the procedure described in paragraph 6.29.2.
- 3) Insert in the frame with the intermediate body the packing gland spring (17), the first packing gland washer (14), the packing gland (15), the second packing gland washer (14).
- 4) Tighten the packing gland screw (13) by two revolutions. **Caution! The packing gland screw keeps the packing gland spring compressed; maximum care shall then be taken to prevent the parts located on the spring from coming out suddenly during the assembly operations.**
- 5) Insert the shutter (18) into the frame with intermediate body (33), carefully greasing it with silicone grease.
- 6) Insert the body gasket (16) into the frame seat (33).
- 7) Insert the previously-assembled frame (33) onto stud-bolts and into the valve body seat (38).
- 8) Insert the spring washers (37) and the elastic washers (36) on the stud-bolts and torque tighten the nuts (35) according to table 6 on page 84.
- 9) Tighten packing gland screw (13) until it is projected by  $\approx 13$  mm from the upper level of intermediate body.
- 10) Tighten nut (12) and adjustment nut (11) on the shutter stem (18) and place adjustment nut in the position kept before valve disassembly to obtain the same calibration, then fasten by nut (12) .
- 11) Place the previously-assembled servo control on the frame with intermediate body (33).
- 12) Insert the flat washers (26) and the elastic washers (27) on the lower head stud-bolts and torque tighten the nuts (28) according to table 6 on page 84.
- 13) Push shutter in contact with seat, then insert as much air into servo control as equivalent to the maximum value provided for by the signal: **Attention! Servo control stem shall move downwards until in contact with adjustment nut (11).**
- 14) Join precharge adjustment nut (11) and servo control shaft (10) with junction clamps (30), insert screws (29) and insert washers (31) on them, then tighten the nuts (32).

**Sectional view of SBS/10 ND 15#50 2-way NO valve**

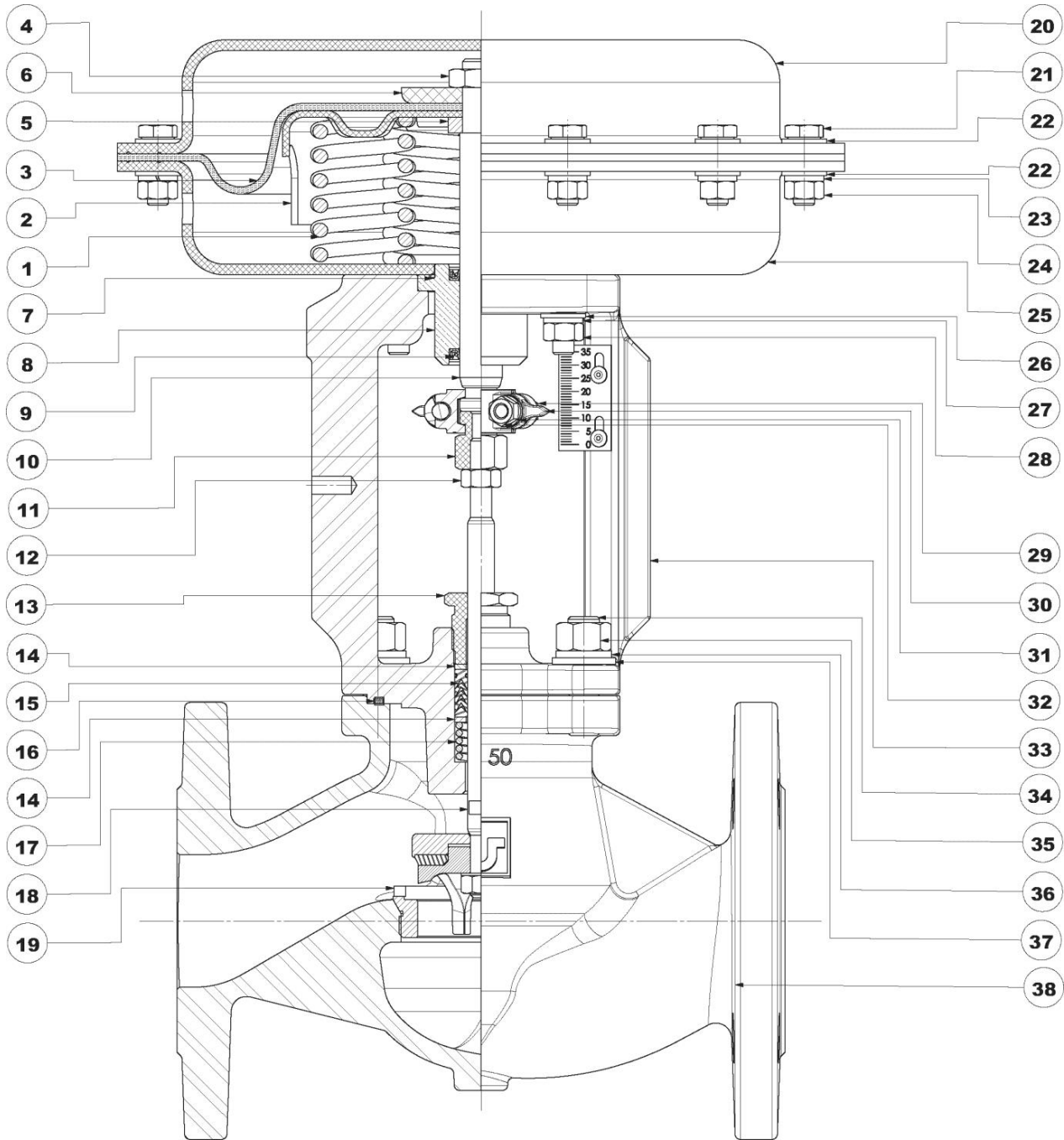

Drawing No. 090265 Rev.:00

## 6.10 Disassembly and assembly instructions for SBS/10 ND 65#80 2-way NO valve

For disassembly and assembly instructions for SBS/10 ND 65#80 2-way NO valve refer to Drw. No. 100662 attached hereby.

Assembly and disassembly operations shall be carried out only personnel qualified in in hydraulics and pneumatics, provided with all the necessary work and safety equipment. Before carrying out any operation on systems and valves, get acquainted with operating temperatures and pressures and any other particular conditions, and take the relevant safety measures.

Whenever operations are to be carried out on valves, remove the fluid completely.

**NOTE: Read the procedures thoroughly before starting any operation.**

### 6.10.1 Disassembly

- 1) Unscrew the nuts (32), extract the washers (31) and the screws (29), separate the junction clamps (30).
- 2) Unscrew the nuts (35), extract the spring washers (36) and the flat washers (37).
- 3) Separate the servo control, the mounting valve from the valve body.
- 4) Untighten adjustment nut (11) and nut (12) carefully making their position.
- 5) Remove the intermediate body (51) with shutter (18).
- 6) Remove the body gasket (50) from the intermediate body (51).
- 7) Remove the shutter from the intermediate body
- 8) Remove air from servo control, unscrew the nuts (28), extract the spring washers (27) and the flat washers (26).
- 9) Separate the mounting from servo control.
- 10) Tighten the packing gland screw (13). **Caution! The packing gland screw (13) keeps the packing gland spring (17) compressed; maximum care shall then be taken to prevent the inner components of frame with intermediate body from coming out suddenly when the packing gland screw (13) is no more kept by the thread.**
- 11) Extract from the intermediate body (33), the first packing gland washer (14), the packing gland (14), the second packing gland washer (15) and the packing gland spring (17).
- 12) Disassemble the servo control following the procedure described in paragraph 6.28.1.
- 13) Now the valve has been completely disassembled, so that the required components can be replaced.

### 6.10.2 Reassembly

- 1) Reassemble the servo control following the procedure described in paragraph 6.28.2.
- 2) Insert in the intermediate body (51) the packing gland spring (17), the first packing gland washer (14), the packing gland (15), the second packing gland washer (14).
- 3) Tighten the packing gland screw (13) by two revolutions. **Caution! The packing gland screw keeps the packing gland spring compressed; maximum care shall then be taken to prevent the parts located on the spring from coming out suddenly during the assembly operations.**
- 4) Insert the shutter (18) into the intermediate body (51), carefully greasing it with silicone grease.
- 5) Insert the body gasket (50) into the intermediate body seat (51).
- 6) Insert the previously-assembled intermediate body (51) onto the valve body seat (38).
- 7) Place precharge adjustment nut (11) in the position kept before valve disassembly to obtain the same calibration, then fasten by nut (12).
- 8) Place the previously-assembled servo control on the mounting (57).
- 9) Insert the flat washers (26) and the elastic washers (27) on the lower head stud-bolts and torque tighten the nuts (28) according to table 6 on page 84.
- 10) Place the servo control with mounting on the valve body (38).
- 11) Insert the spring washers (37) and the elastic washers (36) on the stud-bolts and torque tighten the nuts (35) according to table 6 on page 84.
- 12) Tighten packing gland screw (13) until it is projected by  $\approx 13$  mm from the upper level of intermediate body.
- 13) Lift the shutter until the adjustment nut (11) in contact with the servo control shaft (10).
- 14) Join precharge adjustment nut (11) and servo control shaft (10) with junction clamps (30), insert screws (29) and insert washers (31) on them, then tighten the nuts (32).



**Sectional view of SBS/10 ND 65#80 2-way NO valve**

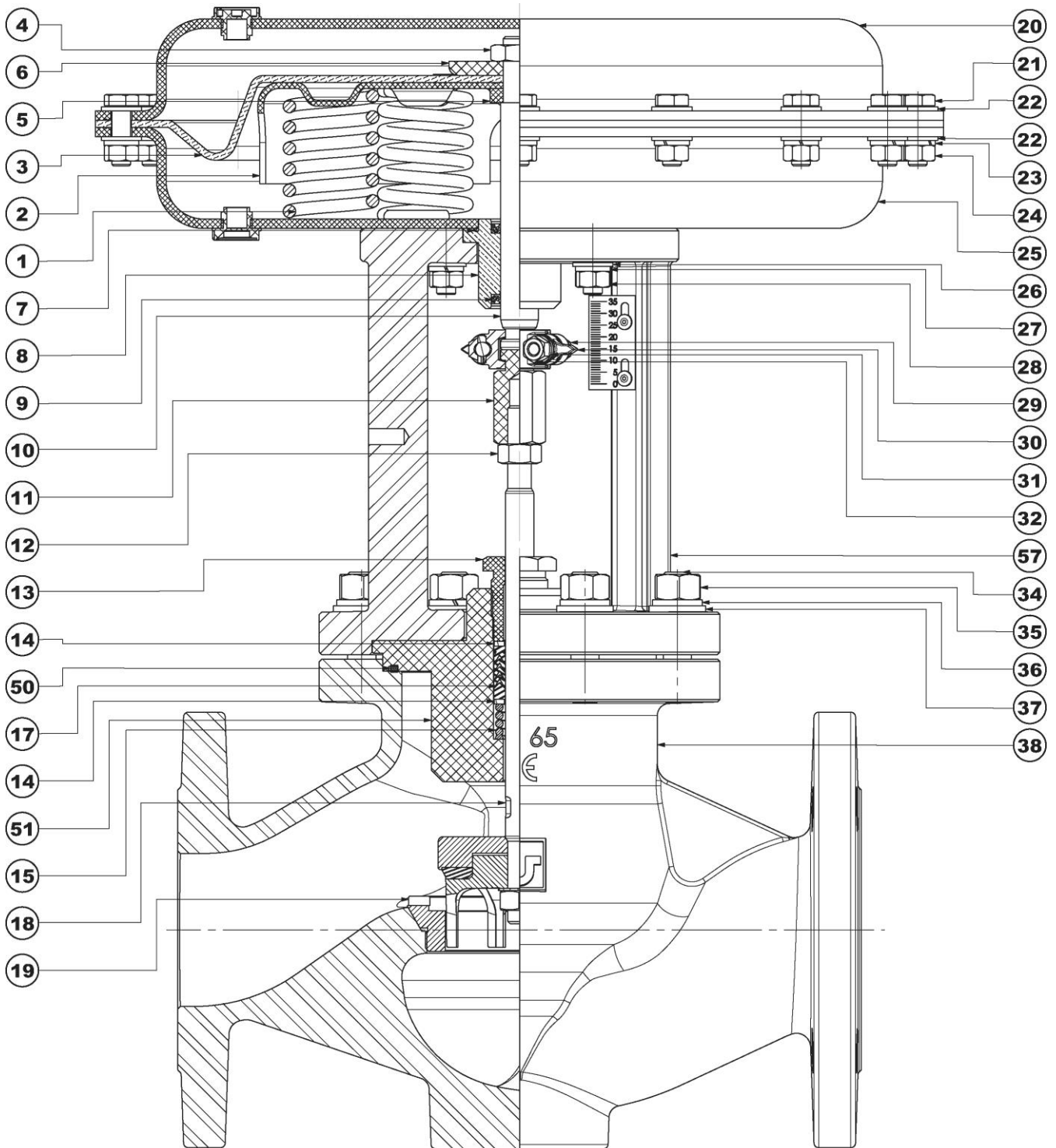

Drawing No. 100662 Rev.:01

## 6.11 Disassembly and assembly instructions for SBS/10 ND 15#50 3-way NC mixer valve

For disassembly and assembly instructions for SBS/10 ND 15#50 3-way NC mixer valve refer to Drw. No. 090266 attached hereby.

Assembly and disassembly operations shall be carried out only personnel qualified in in hydraulics and pneumatics, provided with all the necessary work and safety equipment. Before carrying out any operation on systems and valves, get acquainted with operating temperatures and pressures and any other particular conditions, and take the relevant safety measures.

Whenever operations are to be carried out on valves, remove the fluid completely.

**NOTE: Read the procedures thoroughly before starting any operation.**

### 6.11.1 Disassembly

- 1) Unscrew the nuts (32), extract the washers (31) and the screws (29), separate the junction clamps (30).
- 2) Enter an air signal into the servo control equal to the maximum value provided for by this signal: **Attention! Servo control shaft shall move upwards**
- 3) Unscrew the upper nuts (35), extract the spring washers (36) and the flat washers (37).
- 4) Untighten adjustment nut (11) and nut (12) carefully making their position.
- 5) Separate the servo control and the frame with intermediate body: the shutter remains in the valve body.
- 6) Remove air from servo control, unscrew the nuts (28), extract the spring washers (27) and the flat washers (26).
- 7) Separate the frame with intermediate body from servo control.
- 8) Untighten the packing gland screw (13). **Caution! The packing gland screw (13) keeps the packing gland spring (17) compressed; maximum care shall then be taken to prevent the inner components of frame with intermediate body from coming out suddenly when the packing gland screw (13) is no more kept by the thread.**
- 9) Extract from frame with the intermediate body (33), the first packing gland washer (14), the packing gland (14), the second packing gland washer (15) and the packing gland spring (17).
- 10) Remove the body seal (16) from the frame with intermediate body (33).
- 11) Unscrew the lower nuts (35), extract the spring washers (36) and the flat washers (37).
- 12) Separate the bottom base (40) from the valve body (38).
- 13) Extract the bottom base gasket (39).
- 14) Unscrew the lower seat (19) and extract the shutter (18) from valve body.
- 15) Disassemble the servo control following the procedure described in paragraph 6.27.1.
- 16) Disassemble the shutter following the procedure described in paragraph 6.30.1.
- 17) Now the valve has been completely disassembled, so that the required components can be replaced.

### 6.11.2 Reassembly

- 1) Reassemble the servo control following the procedure described in paragraph 6.27.2.
- 2) Reassemble the shutter following the procedure described in paragraph 6.30.2.
- 3) Insert in the frame with the intermediate body the packing gland spring (17), the first packing gland washer (14), the packing gland (15), the second packing gland washer (14).
- 4) Tighten the packing gland screw (13) by two revolutions. **Caution! The packing gland screw keeps the packing gland spring compressed: maximum care shall then be taken to prevent the parts located on the spring from coming out suddenly during the assembly operations.**
- 5) Insert the body gasket (16) into the frame seat (33).
- 6) Insert the shutter (18) into valve body (38); spread MOTORSIL D (AREXONS) silicone gasket in the contact area between seat and valve body; then, tighten lower seat (19).
- 7) Insert the previously-assembled frame onto stud-bolts, into the valve body seat and onto shutter stem; please remember lubricating the last component with silicone grease.
- 8) Insert the spring washers (37) and the elastic washers (36) on the stud-bolts and torque tighten the nuts (35) according to table 6 on page 84.
- 9) Place the gasket (19) in the bottom base (40).
- 10) Insert the bottom base (40) on the stud-bolts, then insert flat washers (37) and elastic washers (36) and torque tighten the lower nuts (35) according to table 6 on page 84.
- 11) Tighten packing gland screw (13) until it is projected by  $\approx 13$  mm from the upper level of intermediate body.
- 12) Fully tighten on the shutter stem (18) the nut (12) and the adjustment nut (11).
- 13) Place the previously-assembled servo control on the frame with intermediate body (33).
- 14) Insert the flat washers (26) and the elastic washers (27) on the lower head stud-bolts and torque tighten the nuts (28) according to table 6 on page 84.
- 15) Enter air into the servo control equal to the maximum value provided for by this signal: **Attention! Servo control stem shall move upwards in its stroke.**
- 16) Place precharge adjustment nut (11) in the position kept before valve disassembly to obtain the same calibration, then fasten by nut (12).

- 17) Push shutter in contact with seat, then extract air from servo control: **Attention! Servo control stem shall move downwards until in contact with adjustment nut (11).**
- 18) Join precharge adjustment nut (11) and servo control shaft (10) with junction clamps (30), insert screws (29) and insert washers (31) on them, then tighten the nuts (32).

**Sectional view of SBS/10 ND 15#50 3-way NC mixer valve**

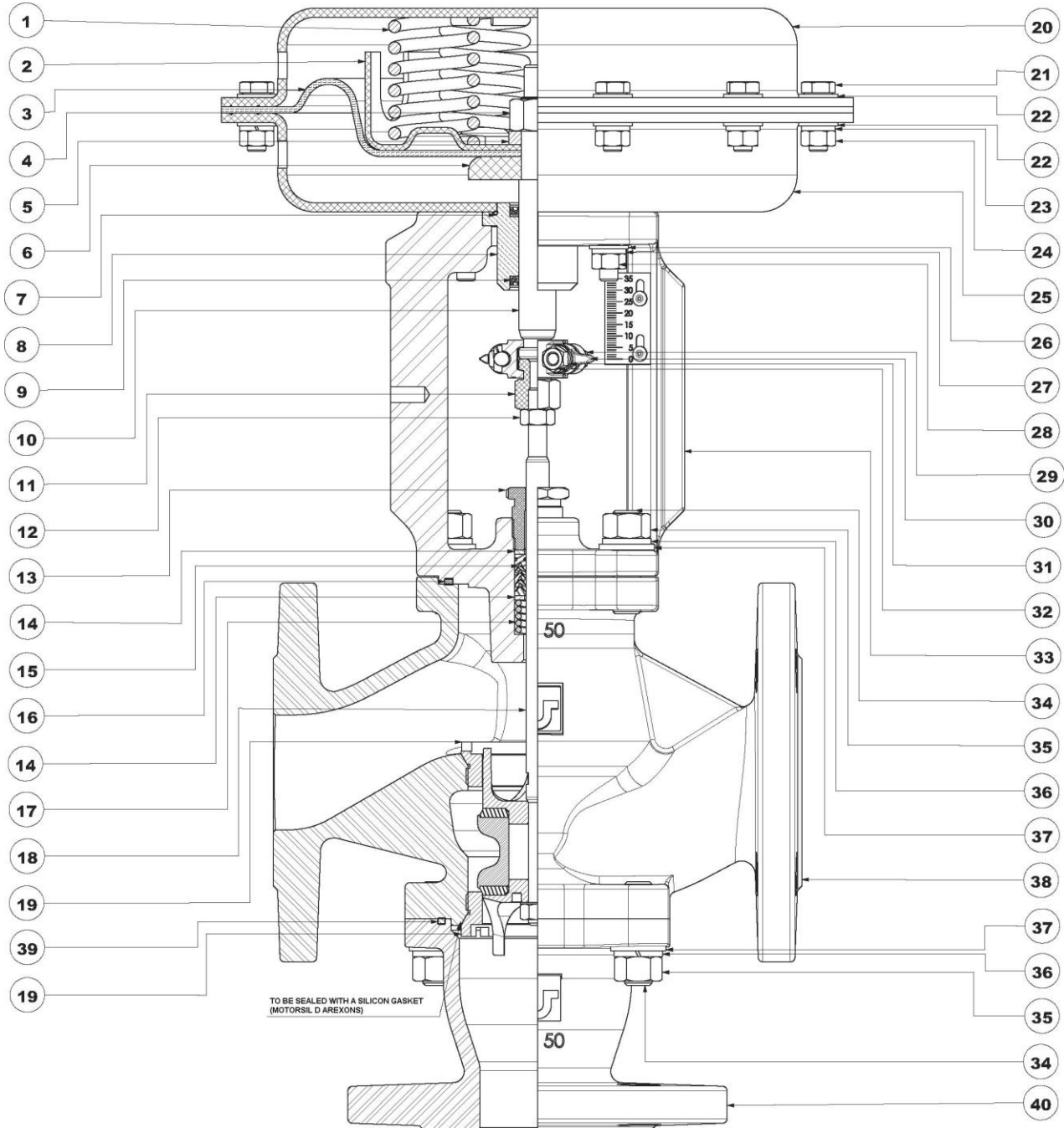

Drawing No. 090266 Rev.:00

## 6.12 Disassembly and assembly instructions for SBS/10 ND 65#80 3-way NC mixer valve

For disassembly and assembly instructions for SBS/10 ND 65#80 3-way NC mixer valve refer to Drw. No. 100661 attached hereby.

Assembly and disassembly operations shall be carried out only personnel qualified in in hydraulics and pneumatics, provided with all the necessary work and safety equipment. Before carrying out any operation on systems and valves, get acquainted with operating temperatures and pressures and any other particular conditions, and take the relevant safety measures.

Whenever operations are to be carried out on valves, remove the fluid completely.

**NOTE: Read the procedures thoroughly before starting any operation.**

### 6.12.1 Disassembly

- 1) Unscrew the nuts (32), extract the washers (31) and the screws (29), separate the junction clamps (30).
- 2) Enter an air signal into the servo control equal to the maximum value provided for by this signal: **Attention! Servo control shaft shall move upwards**
- 3) Unscrew the upper nuts (35), extract the spring washers (36) and the flat washers (37).
- 4) Separate the servo control, the mounting valve from the valve body.
- 5) Untighten adjustment nut (11) and nut (12) carefully making their position.
- 6) Remove air from servo control, unscrew the nuts (28), extract the spring washers (27) and the flat washers (26).
- 7) Separate the mounting from servo control.
- 8) Remove the intermediate body (51).
- 9) Remove the body gasket (50) from the intermediate body (51).
- 10) Untighten the packing gland screw (13). **Caution! The packing gland screw (13) keeps the packing gland spring (17) compressed; maximum care shall then be taken to prevent the inner components of frame with intermediate body from coming out suddenly when the packing gland screw (13) is no more kept by the thread.**
- 11) Extract from the intermediate body (51), the first packing gland washer (14), the packing gland (14), the second packing gland washer (15) and the packing gland spring (17).
- 12) Unscrew the lower nuts (35), extract the spring washers (36) and the flat washers (37).
- 13) Separate the bottom base (40) from the valve body (38).
- 14) Extract the bottom base gasket (39).
- 15) Unscrew the lower seat (19) and extract the shutter (18) from valve body.
- 16) Disassemble the servo control following the procedure described in paragraph 6.27.1.
- 17) Disassemble the shutter following the procedure described in paragraph 6.30.1.
- 18) Now the valve has been completely disassembled, so that the required components can be replaced.

### 6.12.2 Reassembly

- 1) Reassemble the servo control following the procedure described in paragraph 6.27.2.
- 2) Reassemble the shutter following the procedure described in paragraph 6.30.2.
- 3) Insert in the intermediate body (51) the packing gland spring (17), the first packing gland washer (14), the packing gland (15), the second packing gland washer (14).
- 4) Tighten the packing gland screw (13) by two revolutions. **Caution! The packing gland screw keeps the packing gland spring compressed: maximum care shall then be taken to prevent the parts located on the spring from coming out suddenly during the assembly operations.**
- 5) Insert the body gasket (50) into the intermediate body seat (51).
- 6) Insert the shutter (18) into valve body (38); spread MOTORSIL D (AREXONS) silicone gasket in the contact area between seat and valve body; then, tighten lower seat (19).
- 7) Insert the previously-assembled intermediate body, into the valve body seat and onto shutter stem; please remember lubricating the last component with silicone grease.
- 8) Place precharge adjustment nut (11) in the position kept before valve disassembly to obtain the same calibration, then fasten by nut (12).
- 9) Place the previously-assembled servo control on the mounting (57).
- 10) Insert the flat washers (26) and the elastic washers (27) on the lower head stud-bolts and torque tighten the nuts (28) according to table 6 on page 84.
- 11) Enter air into the servo control equal to the maximum value provided for by this signal: **Attention! Servo control stem shall move upwards in its stroke.**
- 12) Place the servo control with mounting on the valve body (38).
- 13) Insert the spring washers (37) and the elastic washers (36) on the stud-bolts and torque tighten the nuts (35) according to table 6 on page 85.
- 14) Place the gasket (19) in the bottom base (40).
- 15) Insert the bottom base (40) on the stud-bolts, then insert flat washers (37) and elastic washers (36) and torque tighten the lower nuts (35) according to table 6 on page 84.

- 16) Tighten packing gland screw (13) until it is projected by  $\approx 13$  mm from the upper level of intermediate body.
- 17) Push shutter in contact with seat, then extract air from servo control: **Attention! Servo control stem shall move downwards until in contact with adjustment nut (11).**
- 18) Join precharge adjustment nut (11) and servo control shaft (10) with junction clamps (30), insert screws (29) and insert washers (31) on them, then tighten the nuts (32).

### Sectional view of SBS/10 ND 65#80 3-way NC mixer valve

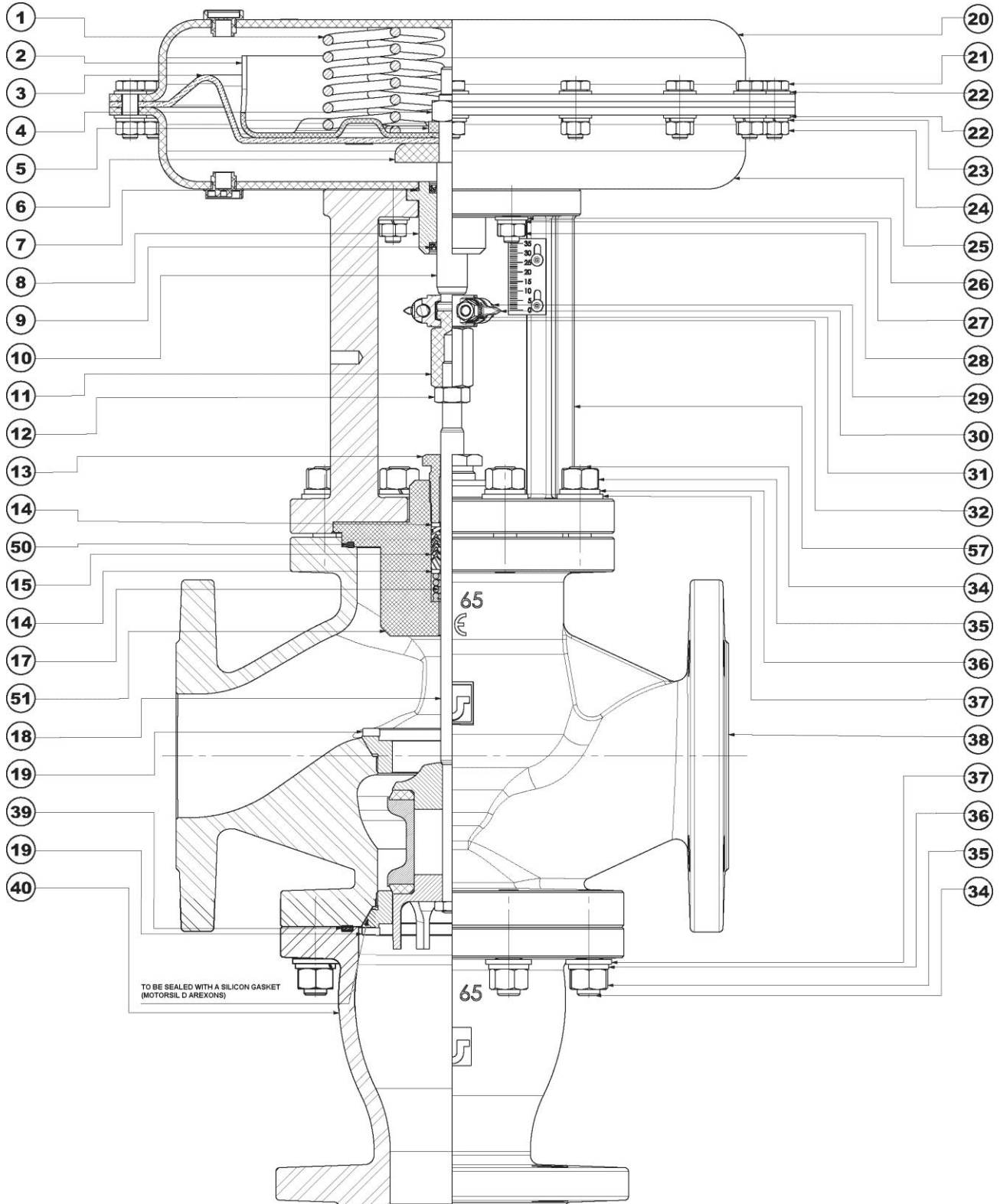

Drawing No. 100661 Rev.:00

## 6.13 Disassembly and assembly instructions for SBS/10 ND 15#50 3-way NO mixer valve

For disassembly and assembly instructions for SBS/10 ND 15#50 3-way NO mixer valve refer to Drw. No. 090902 attached hereby.

Assembly and disassembly operations shall be carried out only personnel qualified in hydraulics and pneumatics, provided with all the necessary work and safety equipment. Before carrying out any operation on systems and valves, get acquainted with operating temperatures and pressures and any other particular conditions, and take the relevant safety measures.

Whenever operations are to be carried out on valves, remove the fluid completely.

**NOTE: Read the procedures thoroughly before starting any operation.**

### 6.13.1 Disassembly

- 1) Enter an air signal into the servo control equal to the maximum value provided for by this signal: **Attention! Valve reaches closing position in lower seat**
- 2) Unscrew the nuts (32), extract the washers (31) and the screws (29), separate the junction clamps (30).
- 3) Blow air out of the servo control.
- 4) Unscrew the upper nuts (35), extract the spring washers (36) and the flat washers (37).
- 5) Untighten adjustment nut (11) and nut (12) carefully making their position.
- 6) Separate the servo control and the frame with intermediate body: the shutter remains in the valve body.
- 7) Unscrew the nuts (28), extract the spring washers (27) and the flat washers (26).
- 8) Separate the frame with intermediate body from servo control.
- 9) Tighten the packing gland screw (13). **Caution! The packing gland screw (13) keeps the packing gland spring (17) compressed; maximum care shall then be taken to prevent the inner components of frame with intermediate body from coming out suddenly when the packing gland screw (13) is no more kept by the thread.**
- 10) Extract from frame with the intermediate body (33), the first packing gland washer (14), the packing gland (14), the second packing gland washer (15) and the packing gland spring (17).
- 11) Remove the body seal (16) from the frame with intermediate body (33).
- 12) Unscrew the lower nuts (35), extract the spring washers (36) and the flat washers (37).
- 13) Separate the bottom base (40) from the valve body (38).
- 14) Extract the bottom base gasket (39).
- 15) Unscrew the lower seat (19) and extract the shutter (18) from valve body.
- 16) Disassemble the servo control following the procedure described in paragraph 6.28.1.
- 17) Disassemble the shutter following the procedure described in paragraph 6.30.1.
- 18) Now the valve has been completely disassembled, so that the required components can be replaced.

### 6.13.2 Reassembly

- 1) Reassemble the servo control following the procedure described in paragraph 6.28.2.
- 2) Reassemble the shutter following the procedure described in paragraph 6.30.2.
- 3) Insert in the frame with the intermediate body the packing gland spring (17), the first packing gland washer (14), the packing gland (15), the second packing gland washer (14).
- 4) Tighten the packing gland screw (13) by two revolutions. **Caution! The packing gland screw keeps the packing gland spring compressed: maximum care shall then be taken to prevent the parts located on the spring from coming out suddenly during the assembly operations.**
- 5) Insert the body gasket (16) into the frame seat (33).
- 6) Insert the shutter (18) into valve body (38); spread MOTORSIL D (AREXONS) silicone gasket in the contact area between seat and valve body; then, tighten lower seat (19).
- 7) Insert the previously-assembled frame onto stud-bolts, into the valve body seat and onto shutter stem; please remember lubricating the last component with silicone grease.
- 8) Insert the spring washers (37) and the elastic washers (36) on the stud-bolts and torque tighten the nuts (35) according to table 6 on page 84.
- 9) Place the gasket (19) in the bottom base (40).
- 10) Insert the bottom base (40) on the stud-bolts, then insert flat washers (37) and elastic washers (36) and torque tighten the lower nuts (35) according to table 6 on page 84.
- 11) Tighten packing gland screw (13) until it is projected by  $\approx 13$  mm from the upper level of intermediate body.
- 12) Tighten nut (12) and adjustment nut (11) on the shutter stem (18): place adjustment nut in the position kept before valve disassembly to obtain the same calibration, then fasten by nut (12).
- 13) Place the previously-assembled servo control on the frame with intermediate body (33).
- 14) Insert the flat washers (26) and the elastic washers (27) on the lower head stud-bolts and torque tighten the nuts (28) according to table 6 on page 84.
- 15) Push shutter in contact with seat, then insert as much air into servo control as equivalent to the maximum value provided for by the signal: **Attention! Servo control stem shall move downwards until in contact with adjustment nut (11).**

- 16) Join precharge adjustment nut (11) and servo control shaft (10) with junction clamps (30), insert screws (29) and insert washers (31) on them, then tighten the nuts (32).

**Sectional view of SBS/10 ND 15#50 3-way NO mixer valve**

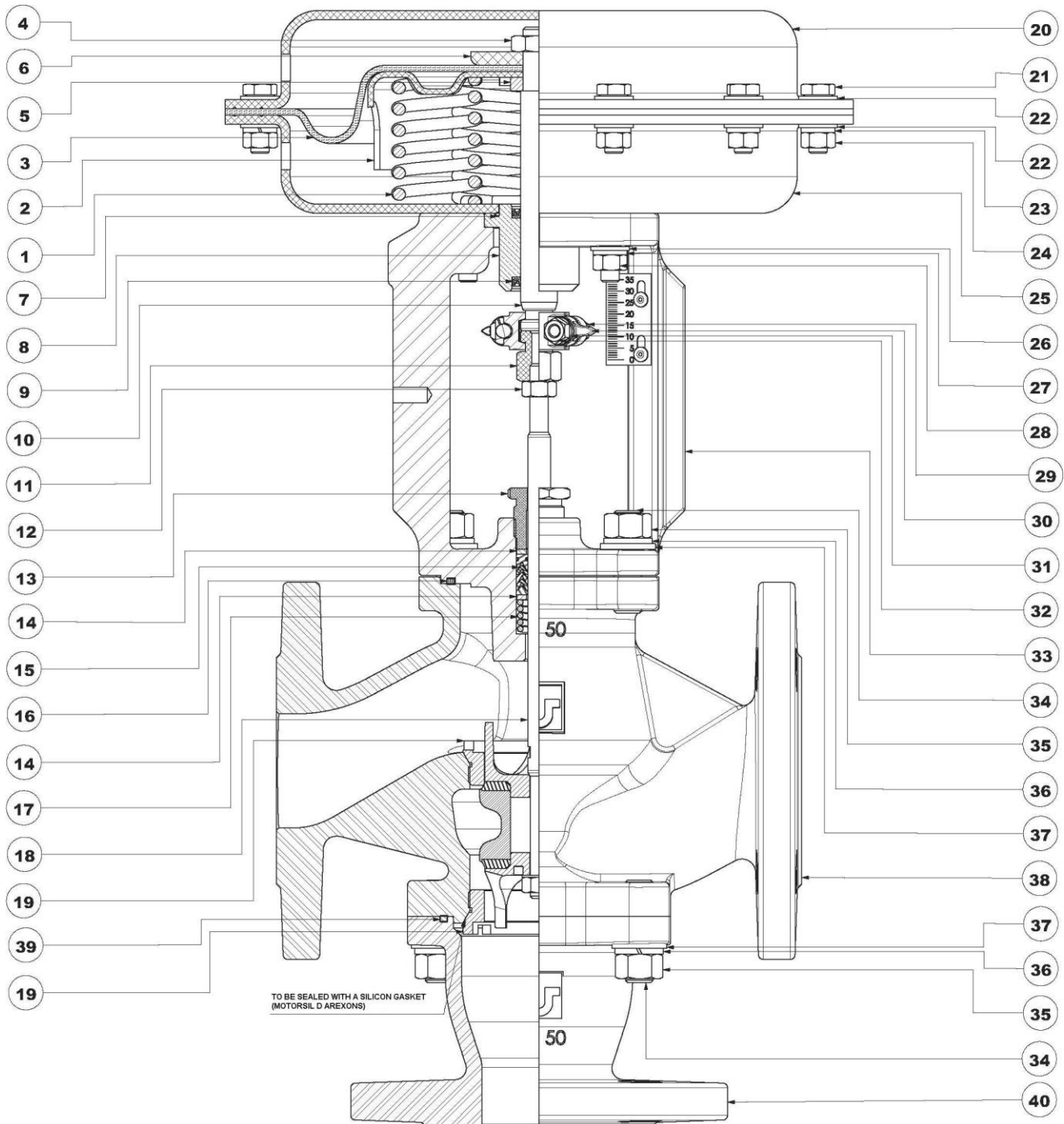

## 6.14 Disassembly and assembly instructions for SBS/10 ND 65#80 3-way NO mixer valve

For disassembly and assembly instructions for SBS/10 ND 65#80 3-way NO mixer valve refer to Drw. No. 100664 attached hereby.

Assembly and disassembly operations shall be carried out only personnel qualified in in hydraulics and pneumatics, provided with all the necessary work and safety equipment. Before carrying out any operation on systems and valves, get acquainted with operating temperatures and pressures and any other particular conditions, and take the relevant safety measures.

Whenever operations are to be carried out on valves, remove the fluid completely.

**NOTE: Read the procedures thoroughly before starting any operation.**

### 6.14.1 Disassembly

- 1) Unscrew the nuts (32), extract the washers (31) and the screws (29), separate the junction clamps (30).
- 2) Unscrew the upper nuts (35), extract the spring washers (36) and the flat washers (37).
- 3) Separate the servo control, the mounting valve from the valve body.
- 4) Untighten adjustment nut (11) and nut (12) carefully making their position.
- 5) Unscrew the nuts (28), extract the spring washers (27) and the flat washers (26).
- 6) Separate the mounting from servo control.
- 7) Remove the intermediate body (51).
- 8) Remove the body gasket (50) from the intermediate body (51).
- 9) Untighten the packing gland screw (13). **Caution! The packing gland screw (13) keeps the packing gland spring (17) compressed; maximum care shall then be taken to prevent the inner components of frame with intermediate body from coming out suddenly when the packing gland screw (13) is no more kept by the thread.**
- 10) Extract from the intermediate body (51), the first packing gland washer (14), the packing gland (14), the second packing gland washer (15) and the packing gland spring (17).
- 11) Unscrew the lower nuts (35), extract the spring washers (36) and the flat washers (37).
- 12) Separate the bottom base (40) from the valve body (38).
- 13) Extract the bottom base gasket (39).
- 14) Unscrew the lower seat (19) and extract the shutter (18) from valve body.
- 15) Disassemble the servo control following the procedure described in paragraph 6.28.1.
- 16) Disassemble the shutter following the procedure described in paragraph 6.30.1.
- 17) Now the valve has been completely disassembled, so that the required components can be replaced.

### 6.14.2 Reassembly

- 1) Reassemble the servo control following the procedure described in paragraph 6.28.2.
- 2) Reassemble the shutter following the procedure described in paragraph 6.30.2.
- 3) Insert in the intermediate body (51) the packing gland spring (17), the first packing gland washer (14), the packing gland (15), the second packing gland washer (14).
- 4) Tighten the packing gland screw (13) by two revolutions. **Caution! The packing gland screw keeps the packing gland spring compressed; maximum care shall then be taken to prevent the parts located on the spring from coming out suddenly during the assembly operations.**
- 5) Insert the body gasket (50) into the intermediate body seat (51).
- 6) Insert the shutter (18) into valve body (38); spread MOTORSIL D (AREXONS) silicone gasket in the contact area between seat and valve body; then, tighten lower seat (19).
- 7) Insert the previously-assembled intermediate body, into the valve body seat and onto shutter stem; please remember lubricating the last component with silicone grease.
- 8) Place precharge adjustment nut (11) in the position kept before valve disassembly to obtain the same calibration, then fasten by nut (12).
- 9) Place the mounting on the valve body (38).
- 10) Insert the spring washers (37) and the elastic washers (36) on the stud-bolts and torque tighten the nuts (35) according to table 6 on page 84.
- 11) Place the previously-assembled servo control on the mounting (57).
- 12) Insert the flat washers (26) and the elastic washers (27) on the lower head stud-bolts and torque tighten the nuts (28) according to table 6 on page 84.
- 13) Place the gasket (19) in the bottom base (40).
- 14) Insert the bottom base (40) on the stud-bolts, then insert flat washers (37) and elastic washers (36) and torque tighten the lower nuts (35) according to table 6 on page 84.
- 15) Tighten packing gland screw (13) until it is projected by  $\approx 13$  mm from the upper level of intermediate body.
- 16) Push shutter in contact with seat, then insert air from servo control: **Attention! Servo control stem shall move downwards until in contact with adjustment nut (11).**
- 17) Join precharge adjustment nut (11) and servo control shaft (10) with junction clamps (30), insert screws (29) and insert washers (31) on them, then tighten the nuts (32).



18) Remove air from the servo control

**Sectional view of SBS/10 ND 65#80 3-way NO mixer valve**

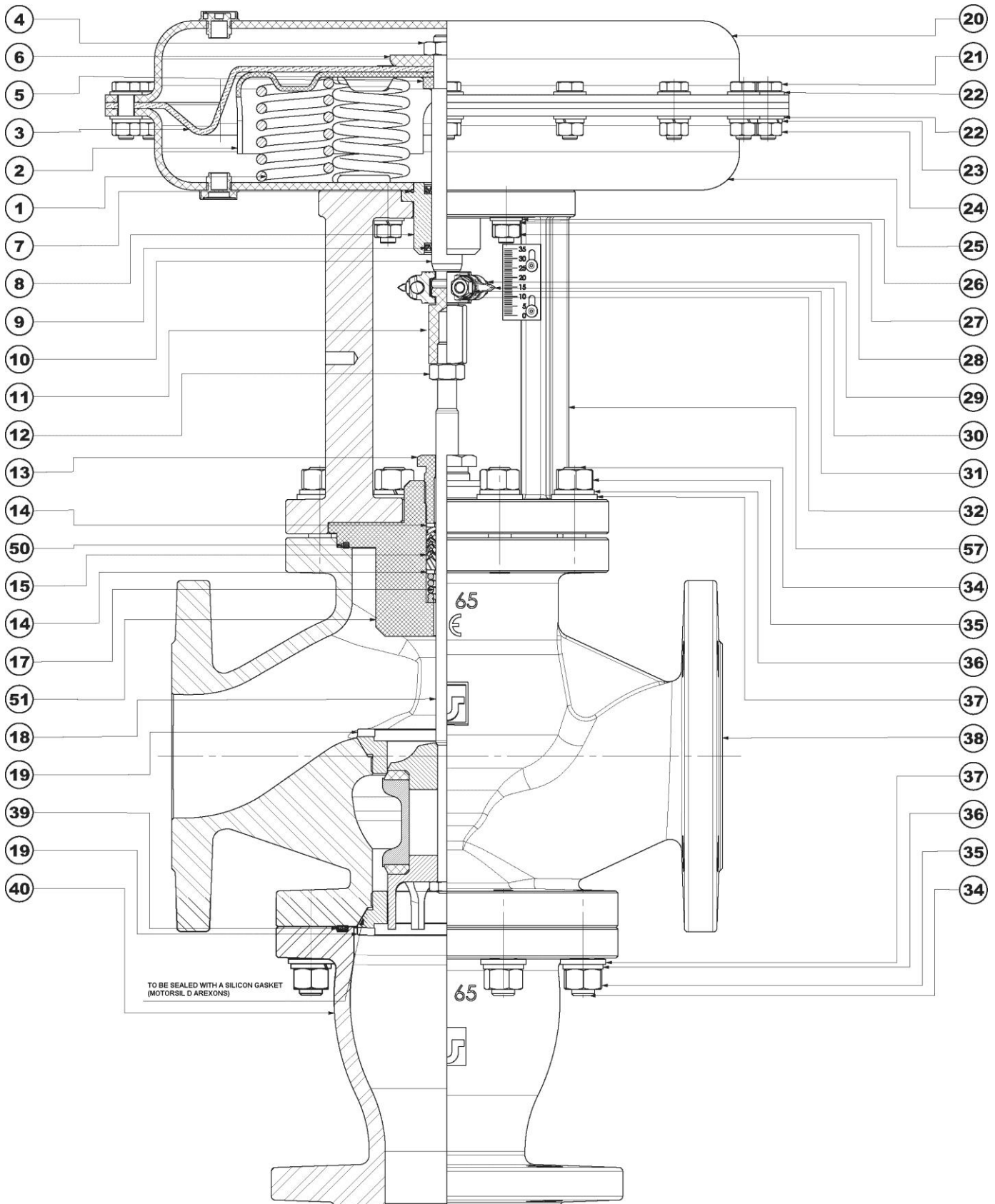

Drawing No. 100664 Rev.:00

## 6.15 Disassembly and assembly instructions for SBS/10 ND 15#50 3-way NC deviator valve

For disassembly and assembly instructions for SBS/10 ND 15#50 3-way NC deviator valve refer to Drw. No. 090903 attached hereby.

Assembly and disassembly operations shall be carried out only personnel qualified in in hydraulics and pneumatics, provided with all the necessary work and safety equipment. Before carrying out any operation on systems and valves, get acquainted with operating temperatures and pressures and any other particular conditions, and take the relevant safety measures.

Whenever operations are to be carried out on valves, remove the fluid completely.

**NOTE: Read the procedures thoroughly before starting any operation.**

### 6.15.1 Disassembly

- 1) Enter an air signal into the servo control equal to the maximum value provided for by this signal: **Attention! Valve reaches closing position in upper seat.**
- 2) Unscrew the nuts (32), extract the washers (31) and the screws (29), separate the junction clamps (30).
- 3) Blow air out of the servo control.
- 4) Unscrew the upper nuts (35), extract the spring washers (36) and the flat washers (37).
- 5) Untighten adjustment nut (11) and nut (12) carefully making their position.
- 6) Separate the servo control and the frame with intermediate body: the shutter remains in the valve body.
- 7) Unscrew the nuts (28), extract the spring washers (27) and the flat washers (26).
- 8) Separate the frame with intermediate body from servo control.
- 9) Tighten the packing gland screw (13). **Caution! The packing gland screw (13) keeps the packing gland spring (17) compressed; maximum care shall then be taken to prevent the inner components of frame with intermediate body from coming out suddenly when the packing gland screw (13) is no more kept by the thread.**
- 10) Separate the frame with intermediate body from body.
- 11) Extract from frame with the intermediate body (33), the first packing gland washer (14), the packing gland (15), the second packing gland washer (14) and the packing gland spring (17).
- 12) Remove the body seal (16) from the frame with intermediate body (33).
- 13) Unscrew the lower nuts (35), extract the spring washers (36) and the flat washers (37).
- 14) Separate the bottom base (40) from the valve body (38).
- 15) Extract the bottom base gasket (39).
- 16) Disassemble the shutter following the procedure described in paragraph 6.31.1.
- 17) Disassemble the servo control following the procedure described in paragraph 6.28.1.
- 18) Now the valve has been completely disassembled, so that the required components can be replaced.

### 6.15.2 Reassembly

- 1) Reassemble the servo control following the procedure described in paragraph 6.28.2.
- 2) Reassemble the shutter (18) and insert into the valve body (38) following the procedure described in paragraph 5.31.2.
- 3) Insert in the frame with the intermediate body the packing gland spring (17), the first packing gland washer (14), the packing gland (15), the second packing gland washer (14).
- 4) Tighten the packing gland screw (13) by two revolutions. **Caution! The packing gland screw keeps the packing gland spring compressed; maximum care shall then be taken to prevent the parts located on the spring from coming out suddenly during the assembly operations.**
- 5) Insert the body gasket (16) into the frame seat (33).
- 6) Insert the previously-assembled frame onto stud-bolts, into the valve body seat (38) and onto shutter stem (18); please remember lubricating the last component with silicone grease.
- 7) Insert the spring washers (37) and the elastic washers (36) on the stud-bolts and torque tighten the nuts (35) according to table 6 on page 84.
- 8) Place the gasket (19) in the bottom base (40).
- 9) Insert the bottom base (40) on the stud-bolts, then insert flat washers (37) and elastic washers (36) and torque tighten the lower nuts (35) according to table 6 on page 84.
- 10) Tighten packing gland screw (13) until it is projected by  $\approx 13$  mm from the upper level of intermediate body.
- 11) Tighten nut (12) and adjustment nut (11) on the shutter stem (18); place adjustment nut in the position kept before valve disassembly to obtain the same calibration, then fasten by nut (12) .
- 12) Place the previously-assembled servo control on the frame with intermediate body (33).
- 13) Insert the flat washers (26) and the elastic washers (27) on the lower head stud-bolts; torque tighten the nuts (28) according to table 6 on page 84.
- 14) Push shutter downward in contact with seat, then insert as much air into servo control as equivalent to the maximum value provided for by the signal: **Attention! Servo control stem shall move downwards until in contact with adjustment nut (11).**

- 15) Join precharge adjustment nut (11) and servo control shaft (10) with junction clamps (30); insert screws (29) and insert washers (31) on them, then tighten the nuts (32).

**Sectional view of SBS/10 ND 15#50 3-way NC deviator valve**

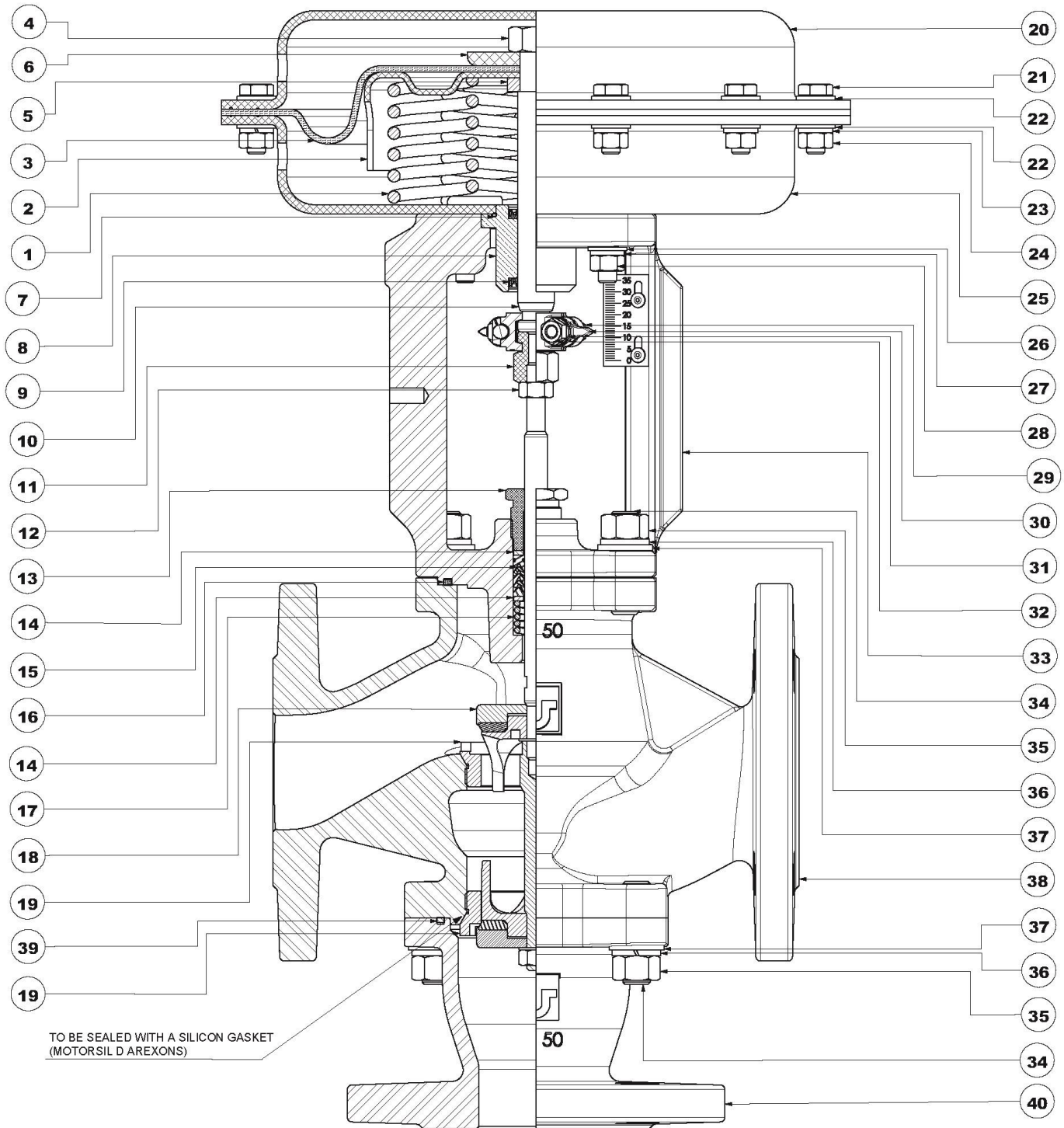

Drawing No. 090903 Rev.:00

## 6.16 Disassembly and assembly instructions for SBS/10 ND 65#80 3-way NC deviator valve

For disassembly and assembly instructions for SBS/10 ND 65#80 3-way NC deviator valve refer to Drw. No. 100665 attached hereby.

Assembly and disassembly operations shall be carried out only personnel qualified in in hydraulics and pneumatics, provided with all the necessary work and safety equipment. Before carrying out any operation on systems and valves, get acquainted with operating temperatures and pressures and any other particular conditions, and take the relevant safety measures.

Whenever operations are to be carried out on valves, remove the fluid completely.

**NOTE: Read the procedures thoroughly before starting any operation.**

### 6.16.1 Disassembly

- 1) Unscrew the nuts (32), extract the washers (31) and the screws (29), separate the junction clamps (30).
- 2) Unscrew the upper nuts (35), extract the spring washers (36) and the flat washers (37).
- 3) Separate the servo control, the mounting valve from the valve body.
- 4) Untighten adjustment nut (11) and nut (12) carefully making their position.
- 5) Unscrew the nuts (28), extract the spring washers (27) and the flat washers (26).
- 6) Separate the mounting from servo control.
- 7) Remove the intermediate body (51).
- 8) Remove the body gasket (50) from the intermediate body (51).
- 9) Untighten the packing gland screw (13). **Caution! The packing gland screw (13) keeps the packing gland spring (17) compressed; maximum care shall then be taken to prevent the inner components of frame with intermediate body from coming out suddenly when the packing gland screw (13) is no more kept by the thread.**
- 10) Extract from the intermediate body (51), the first packing gland washer (14), the packing gland (14), the second packing gland washer (15) and the packing gland spring (17).
- 11) Unscrew the lower nuts (35), extract the spring washers (36) and the flat washers (37).
- 12) Separate the bottom base (40) from the valve body (38).
- 13) Extract the bottom base gasket (39).
- 14) Disassemble the shutter following the procedure described in paragraph 6.31.1.
- 15) Disassemble the servo control following the procedure described in paragraph 6.28.1.
- 16) Now the valve has been completely disassembled, so that the required components can be replaced.

### 6.16.2 Reassembly

- 1) Reassemble the servo control following the procedure described in paragraph 6.28.2.
- 2) Reassemble the shutter (18) and insert in body valve (38) following the procedure described in paragraph 5.31.2.
- 3) Insert in the intermediate body (51) the packing gland spring (17), the first packing gland washer (14), the packing gland (15), the second packing gland washer (14).
- 4) Tighten the packing gland screw (13) by two revolutions. **Caution! The packing gland screw keeps the packing gland spring compressed; maximum care shall then be taken to prevent the parts located on the spring from coming out suddenly during the assembly operations.**
- 5) Insert the body gasket (50) into the intermediate body seat (51).
- 6) Insert the previously-assembled intermediate body, into the valve body seat and onto shutter stem; please remember lubricating the last component with silicone grease.
- 7) Place precharge adjustment nut (11) in the position kept before valve disassembly to obtain the same calibration, then fasten by nut (12).
- 8) Place the mounting on the valve body (38).
- 9) Insert the spring washers (37) and the elastic washers (36) on the stud-bolts and torque tighten the nuts (35) according to table 6 on page 84.
- 10) Place the gasket (19) in the bottom base (40).
- 11) Insert the bottom base (40) on the stud-bolts, then insert flat washers (37) and elastic washers (36) and torque tighten the lower nuts (35) according to table 6 on page 84.
- 12) Tighten packing gland screw (13) until it is projected by  $\approx 13$  mm from the upper level of intermediate body.
- 13) Place the previously-assembled servo control on the mounting (57).
- 14) Insert the flat washers (26) and the elastic washers (27) on the lower head stud-bolts and torque tighten the nuts (28) according to table 6 on page 84.
- 15) Push shutter in contact with seat, then insert air from servo control: **Attention! Servo control stem shall move downwards until in contact with adjustment nut (11).**
- 16) Join precharge adjustment nut (11) and servo control shaft (10) with junction clamps (30), insert screws (29) and insert washers (31) on them, then tighten the nuts (32).
- 17) Remove air from the servo control

**Sectional view of SBS/10 ND 65#80 3-way NC deviator valve**

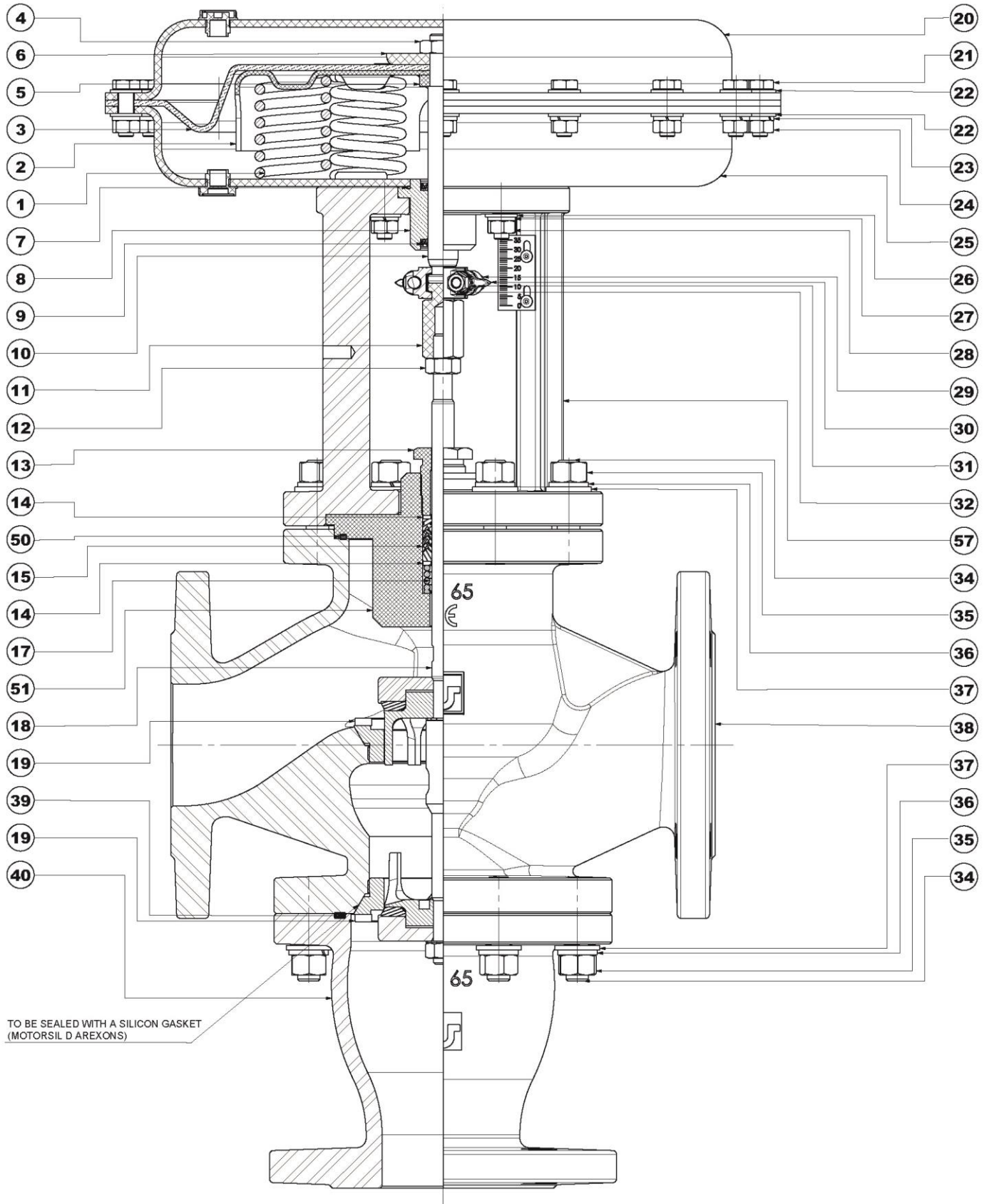

Drawing No. 100665 Rev.:00

## 6.17 Disassembly and assembly instructions for SBS/10 ND 15#50 3-way NO deviator valve

For disassembly and assembly instructions for SBS/10 ND 15#50 3-way NO deviator valve refer to Drw. No. 090267 attached hereby.

Assembly and disassembly operations shall be carried out only personnel qualified in in hydraulics and pneumatics, provided with all the necessary work and safety equipment. Before carrying out any operation on systems and valves, get acquainted with operating temperatures and pressures and any other particular conditions, and take the relevant safety measures.

Whenever operations are to be carried out on valves, remove the fluid completely.

**NOTE: Read the procedures thoroughly before starting any operation.**

### 6.17.1 Disassembly

- 1) Unscrew the nuts (32), extract the washers (31) and the screws (29), separate the junction clamps (30).
- 2) Enter an air signal into the servo control equal to the maximum value provided for by this signal: **Attention! Servo control shaft shall move upwards**
- 3) Unscrew the upper nuts (35), extract the spring washers (36) and the flat washers (37).
- 4) Untighten adjustment nut (11) and nut (12) carefully making their position.
- 5) Separate the servo control and the frame with intermediate body: the shutter remains in the valve body.
- 6) Remove air from servo control, unscrew the nuts (28), extract the spring washers (27) and the flat washers (26).
- 7) Separate the frame with intermediate body from servo control.
- 8) Untighten the packing gland screw (13). **Caution! The packing gland screw (13) keeps the packing gland spring (17) compressed; maximum care shall then be taken to prevent the inner components of frame with intermediate body from coming out suddenly when the packing gland screw (13) is no more kept by the thread.**
- 9) Separate the frame with intermediate body from body.
- 10) Extract from frame with the intermediate body (33), the first packing gland washer (14), the packing gland (15), the second packing gland washer (14) and the packing gland spring (17).
- 11) Remove the body seal (16) from the frame with intermediate body (33).
- 12) Unscrew the lower nuts (35), extract the spring washers (36) and the flat washers (37).
- 13) Separate the bottom base (40) from the valve body (38).
- 14) Extract the bottom base gasket (39).
- 15) Disassemble the shutter following the procedure described in paragraph 6.31.1.
- 16) Disassemble the servo control following the procedure described in paragraph 6.27.1.
- 17) Now the valve has been completely disassembled, so that the required components can be replaced.

### 6.17.2 Reassembly

- 1) Reassemble the servo control following the procedure described in paragraph 6.27.2.
- 2) Reassemble the shutter (18) and insert into the valve body (38) following the procedure described in paragraph 5.31.2.
- 3) Insert in the frame with the intermediate body the packing gland spring (17), the first packing gland washer (14), the packing gland (15), the second packing gland washer (14).
- 4) Tighten the packing gland screw (13) by two revolutions. **Caution! The packing gland screw keeps the packing gland spring compressed; maximum care shall then be taken to prevent the parts located on the spring from coming out suddenly during the assembly operations.**
- 5) Insert the body gasket (16) into the frame seat (33).
- 6) Insert the previously-assembled frame onto stud-bolts, into the valve body seat (38) and onto shutter stem (18); please remember lubricating the last component with silicone grease.
- 7) Insert the spring washers (37) and the elastic washers (36) on the stud-bolts and torque tighten the nuts (35) according to table 6 on page 84.
- 8) Place the gasket (19) in the bottom base (40).
- 9) Insert the bottom base (40) on the stud-bolts, then insert flat washers (37) and elastic washers (36) and torque tighten the lower nuts (35) according to table 6 on page 84.
- 10) Tighten packing gland screw (13) until it is projected by  $\approx 13$  mm from the upper level of intermediate body.
- 11) Fully tighten on the shutter stem (18) the nut (12) and the adjustment nut (11).
- 12) Place the previously-assembled servo control on the frame with intermediate body (33).
- 13) Insert the flat washers (26) and the elastic washers (27) on the lower head stud-bolts and torque tighten the nuts (28) according to table 6 on page 84.
- 14) Enter air into the servo control equal to the maximum value provided for by this signal: **Attention! Servo control stem shall move upwards in its stroke.**
- 15) Place precharge adjustment nut (11) in the position kept before valve disassembly to obtain the same calibration, then fasten by nut (12).



- 16) Push shutter downward in contact with seat, then extract air from servo control: **Attention! Servo control stem shall move downwards until in contact with adjustment nut (11).**
- 17) Join precharge adjustment nut (11) and servo control shaft (10) with junction clamps (30); insert screws (29) and insert washers (31) on them, then tighten the nuts (32).

**Sectional view of SBS/10 ND 15#50 3-way NO deviator valve**

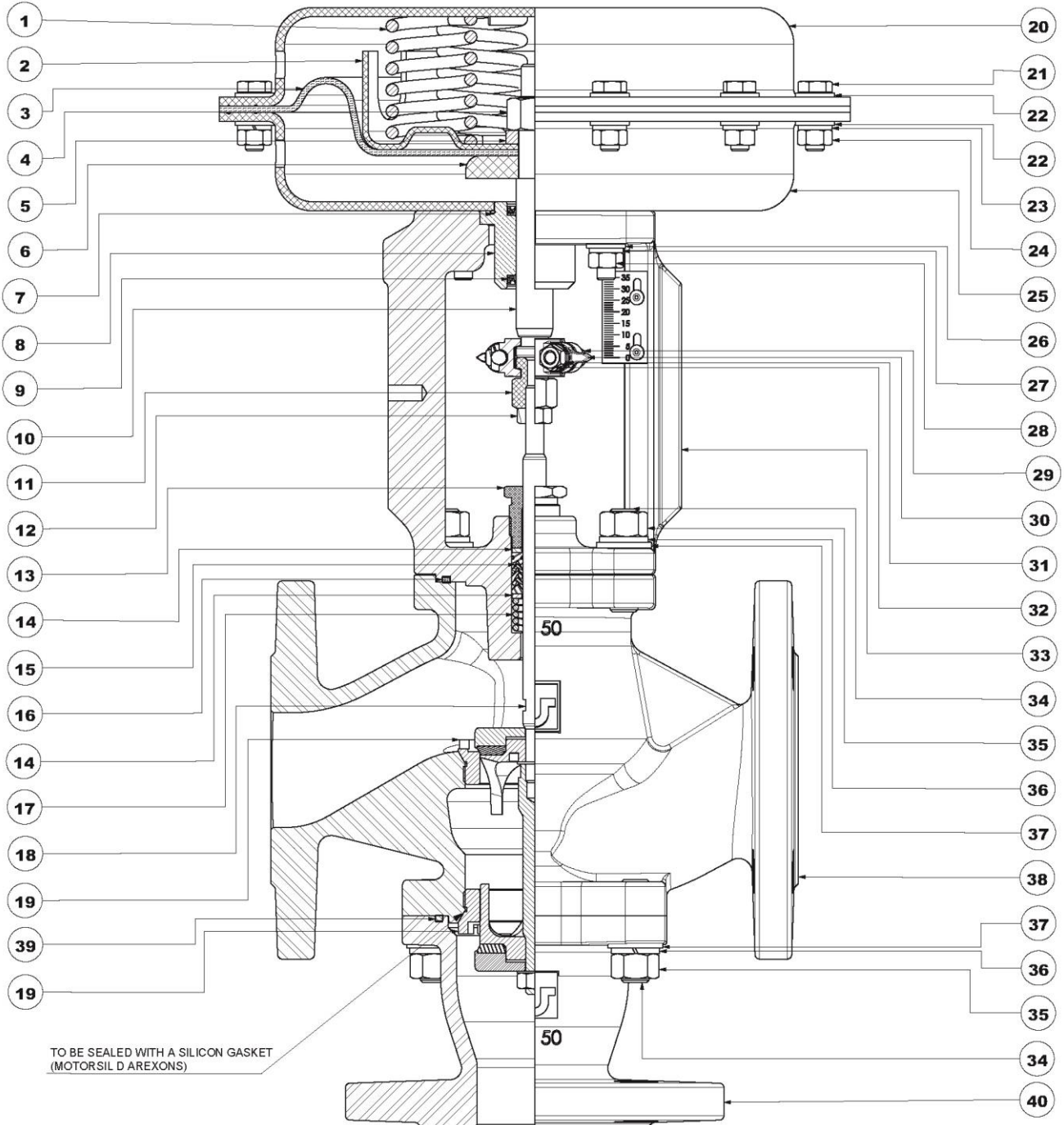

Drawing No. 090267 Rev.:00

## 6.18 Disassembly and assembly instructions for SBS/10 ND 65#80 3-way NO deviator valve

For disassembly and assembly instructions for SBS/10 ND 65#80 3-way NO deviator valve refer to Drw. No. 100660 attached hereby.

Assembly and disassembly operations shall be carried out only personnel qualified in hydraulics and pneumatics, provided with all the necessary work and safety equipment. Before carrying out any operation on systems and valves, get acquainted with operating temperatures and pressures and any other particular conditions, and take the relevant safety measures.

Whenever operations are to be carried out on valves, remove the fluid completely.

**NOTE: Read the procedures thoroughly before starting any operation.**

### 6.18.1 Disassembly

- 1) Unscrew the nuts (32), extract the washers (31) and the screws (29), separate the junction clamps (30).
- 2) Enter an air signal into the servo control equal to the maximum value provided for by this signal: **Attention! Servo control shaft shall move upwards**
- 3) Unscrew the upper nuts (35), extract the spring washers (36) and the flat washers (37).
- 4) Separate the servo control, the mounting valve from the valve body.
- 5) Remove air from the servo control.
- 6) Unscrew the nuts (28), extract the spring washers (27) and the flat washers (26).
- 7) Separate the mounting from servo control.
- 8) Untighten adjustment nut (11) and nut (12) carefully making their position.
- 9) Remove the intermediate body (51).
- 10) Remove the body gasket (50) from the intermediate body (51).
- 11) Untighten the packing gland screw (13). **Caution! The packing gland screw (13) keeps the packing gland spring (17) compressed; maximum care shall then be taken to prevent the inner components of frame with intermediate body from coming out suddenly when the packing gland screw (13) is no more kept by the thread.**
- 12) Extract from the intermediate body (51), the first packing gland washer (14), the packing gland (14), the second packing gland washer (15) and the packing gland spring (17).
- 13) Unscrew the lower nuts (35), extract the spring washers (36) and the flat washers (37).
- 14) Separate the bottom base (40) from the valve body (38).
- 15) Extract the bottom base gasket (39).
- 16) Disassemble the shutter following the procedure described in paragraph 6.31.1.
- 17) Disassemble the servo control following the procedure described in paragraph 6.27.1.
- 18) Now the valve has been completely disassembled, so that the required components can be replaced.

### 6.18.2 Reassembly

- 1) Reassemble the servo control following the procedure described in paragraph 6.27.2.
- 2) Reassemble the shutter (18) and insert in body valve (38) following the procedure described in paragraph 5.31.2.
- 3) Insert in the intermediate body (51) the packing gland spring (17), the first packing gland washer (14), the packing gland (15), the second packing gland washer (14).
- 4) Tighten the packing gland screw (13) by two revolutions. **Caution! The packing gland screw keeps the packing gland spring compressed; maximum care shall then be taken to prevent the parts located on the spring from coming out suddenly during the assembly operations.**
- 5) Insert the body gasket (50) into the intermediate body seat (51).
- 6) Insert the previously-assembled intermediate body, into the valve body seat and onto shutter stem; please remember lubricating the last component with silicone grease.
- 7) Place precharge adjustment nut (11) in the position kept before valve disassembly to obtain the same calibration, then fasten by nut (12).
- 8) Place the servo control on the mounting (57).
- 9) Insert the flat washers (26) and the elastic washers (27) on the lower head stud-bolts and torque tighten the nuts (28) according to table 6 on page 84.
- 10) Enter an air signal into the servo control equal to the maximum value provided for by this signal: **Attention! Servo control shaft shall move upwards**
- 11) Place the previously-assembled servo control with the mounting (57) on the valve body (38).
- 12) Insert the spring washers (37) and the elastic washers (36) on the stud-bolts and torque tighten the nuts (35) according to table 6 on page 82.
- 13) Place the gasket (19) in the bottom base (40).
- 14) Insert the bottom base (40) on the stud-bolts, then insert flat washers (37) and elastic washers (36) and torque tighten the lower nuts (35) according to table 6 on page 84.
- 15) Tighten packing gland screw (13) until it is projected by  $\approx 13$  mm from the upper level of intermediate body.



- 16) Push shutter in contact with seat, then remove air from servo control: **Attention! Servo control stem shall move downwards until in contact with adjustment nut (11).**
- 17) Join precharge adjustment nut (11) and servo control shaft (10) with junction clamps (30), insert screws (29) and insert washers (31) on them, then tighten the nuts (32).

**Sectional view of SBS/10 ND 65#80 3-way NO deviator valve**

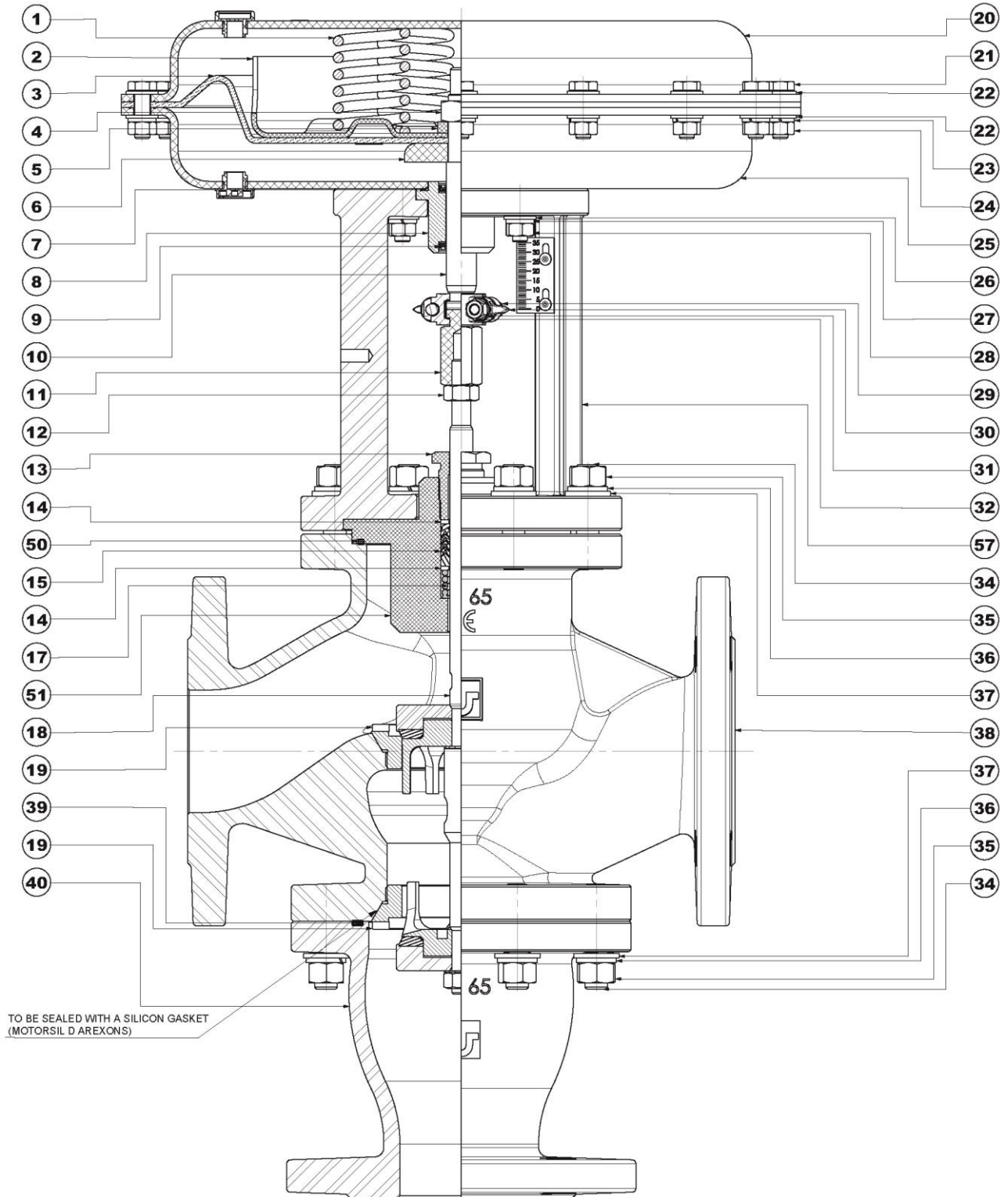

Drawing No. 100660 Rev.:00

## 6.19 Disassembly and assembly instructions for SBS/10 ND 15#50 2-way NC valve with bellows

For disassembly and assembly instructions for SBS/10 ND 15#50 2-way NC valve with bellows refer to Drw. No. 090917 attached hereby.

Assembly and disassembly operations shall be carried out only personnel qualified in in hydraulics and pneumatics, provided with all the necessary work and safety equipment. Before carrying out any operation on systems and valves, get acquainted with operating temperatures and pressures and any other particular conditions, and take the relevant safety measures.

Whenever operations are to be carried out on valves, remove the fluid completely.

**NOTE: Read the procedures thoroughly before starting any operation.**

### 6.19.1 Disassembly

- 1) Unscrew the nuts (32), extract the washers (31) and the screws (29), separate the junction clamps (30).
- 2) Enter an air signal into the servo control equal to the maximum value provided for by this signal: **Attention! Servo control shaft shall move upwards**
- 3) Untighten adjustment nut (11) and nut (12) carefully making their position.
- 4) Unscrew the nuts (48), extract the spring washers (47), the flat washers (46) and the screws (45).
- 5) Separate the servo control and the frame with intermediate body frame extension (49).
- 6) Remove air from servo control, unscrew the nuts (28), extract the spring washers (27) and the flat washers (26).
- 7) Separate the frame with intermediate body from servo control.
- 8) Untighten the packing gland screw (13). **Caution! The packing gland screw (13) keeps the packing gland spring (17) compressed; maximum care shall then be taken to prevent the inner components of frame with intermediate body from coming out suddenly when the packing gland screw (13) is no more kept by the thread.**
- 9) Extract from frame with the intermediate body (33), the first packing gland washer (14), the packing gland (14), the second packing gland washer (15) and the packing gland spring (17).
- 10) Remove the body seal (16) from the frame with intermediate body (33).
- 11) Unscrew the nuts (35), extract the spring washers (36), the flat washers (37) and the frame extension (49).
- 12) Extract the intermediate body with bellows (43) with upper stem (41) and shutter (18) connected with it from the valve body (38).
- 13) Extract the headless screw (42), the with upper stem (41) and shutter (18) from the intermediate body with bellows (43).
- 14) Remove gaskets (44) and (16) from intermediate body with bellows.
- 15) Disassemble the servo control following the procedure described in paragraph 6.27.1.
- 16) Now the valve has been completely disassembled, so that the required components can be replaced.

### 6.19.2 Reassembly

- 1) Reassemble the servo control following the procedure described in paragraph 6.27.2.
- 2) Insert gaskets (16) and (44) into intermediate body with bellows.
- 3) Screw shutter (18) to intermediate body with bellows (43), by using NT 907 TS (RESBOND) threading dope as shown in drawing.
- 4) Tighten the upper stem (41) inside the intermediate body with bellows (43) and fasten by headless screw (42).
- 5) Insert the intermediate body with bellows assembled inside the valve body (38).
- 6) Place the frame extension (49) inside the intermediate body with bellows in correspondence with stud-bolts (34).
- 7) Insert the spring washers (37) and the elastic washers (36) on the stud-bolts and torque tighten the nuts (35) according to table 6 on page 84.
- 8) Insert in the frame with the intermediate body the packing gland spring (17), the first packing gland washer (14), the packing gland (15), the second packing gland washer (14).
- 9) Tighten the packing gland screw (13) by two revolutions. **Caution! The packing gland screw keeps the packing gland spring compressed; maximum care shall then be taken to prevent the parts located on the spring from coming out suddenly during the assembly operations.**
- 10) Place the gasket (16) into the frame seat (33).
- 11) Insert the previously-assembled frame into the frame extension (49) and onto the upper stem (41).
- 12) Insert washers (46) into screws (45) and the screws into the frame (33).
- 13) Insert the flat washers (46) and the elastic washers (47) on the screws (45) and torque tighten the nuts (48) according to table 6 on page 84.
- 14) Tighten packing gland screw (13) until it is projected by  $\approx 13$  mm from the upper level of intermediate body.
- 15) Fully tighten on the upper stem (41) the nut (12) and the adjustment nut (11).
- 16) Place the previously-assembled servo control on the frame with intermediate body (33).
- 17) Insert the flat washers (26) and the elastic washers (27) on the lower head stud-bolts and torque tighten the nuts (28) according to table 6 on page 84.
- 18) Enter air into the servo control equal to the maximum value provided for by this signal: **Attention! Servo control stem shall move upwards in its stroke.**

- 19) Place precharge adjustment nut (11) in the position kept before valve disassembly to obtain the same calibration, then fasten by nut (12).
- 20) Extract air from servo control: **Attention! Servo control stem shall move downwards until in contact with adjustment nut (11).**
- 21) Join precharge adjustment nut (11) and servo control shaft (10) with junction clamps (30); insert screws (29) and insert washers (31) on them, then tighten the nuts (32).

### Sectional view of SBS/10 ND 15#50 2-way NC valve with bellows

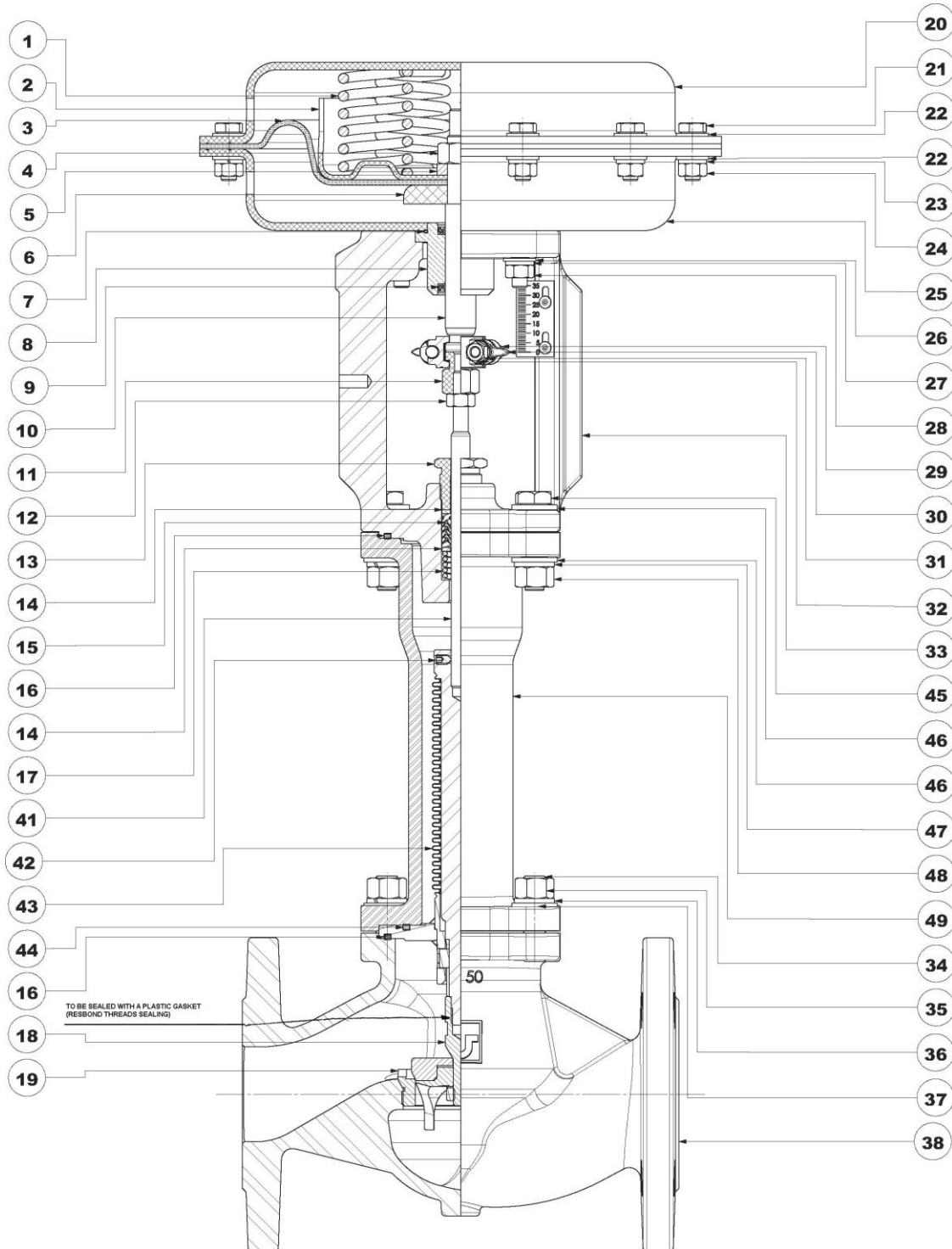

Drawing No. 090917 Rev.:00

## 6.20 Disassembly and assembly instructions for SBS/10 ND 65#80 2-way NC valve with bellows

For disassembly and assembly instructions for SBS/10 ND 65#80 2-way NC valve with bellows refer to Drw. No. 100673 attached hereby.

Assembly and disassembly operations shall be carried out only personnel qualified in in hydraulics and pneumatics, provided with all the necessary work and safety equipment. Before carrying out any operation on systems and valves, get acquainted with operating temperatures and pressures and any other particular conditions, and take the relevant safety measures.

Whenever operations are to be carried out on valves, remove the fluid completely.

**NOTE: Read the procedures thoroughly before starting any operation.**

### 6.20.1 Disassembly

- 1) Unscrew the nuts (32), extract the washers (31) and the screws (29), separate the junction clamps (30).
- 2) Enter an air signal into the servo control equal to the maximum value provided for by this signal: **Attention! Servo control shaft shall move upwards**
- 3) Untighten adjustment nut (11) and nut (12) carefully making their position.
- 4) Unscrew the nuts (48), extract the spring washers (47), the flat washers (46) and the screws (45).
- 5) Separate the servo control and the frame with intermediate body frame extension (49).
- 6) Remove air from servo control, unscrew the nuts (28), extract the spring washers (27) and the flat washers (26).
- 7) Separate the frame with intermediate body from servo control.
- 8) Untighten the packing gland screw (13). **Caution! The packing gland screw (13) keeps the packing gland spring (17) compressed; maximum care shall then be taken to prevent the inner components of frame with intermediate body from coming out suddenly when the packing gland screw (13) is no more kept by the thread.**
- 9) Extract from frame with the intermediate body (33), the first packing gland washer (14), the packing gland (14), the second packing gland washer (15) and the packing gland spring (17).
- 10) Remove the body seal (16) from the frame with intermediate body (33).
- 11) Unscrew the nuts (35), extract the spring washers (36), the flat washers (37) and the frame extension (49).
- 12) Extract the intermediate body with bellows (43) with upper stem (41) and shutter (18) connected with it from the valve body (38).
- 13) Extract the headless screw (42), the with upper stem (41) and shutter (18) from the intermediate body with bellows (43).
- 14) Remove gaskets (44) and (58) from intermediate body with bellows.
- 15) Disassemble the servo control following the procedure described in paragraph 6.27.1.
- 16) Now the valve has been completely disassembled, so that the required components can be replaced.

### 6.20.2 Reassembly

- 1) Reassemble the servo control following the procedure described in paragraph 6.27.2.
- 2) Insert gaskets (58) and (44) into intermediate body with bellows.
- 3) Screw shutter (18) to intermediate body with bellows (43), by using NT 907 TS (RESBOND) threading dope as shown in drawing.
- 4) Tighten the upper stem (41) inside the intermediate body with bellows (43) and fasten by headless screw (42).
- 5) Insert the intermediate body with bellows assembled inside the valve body (38).
- 6) Place the frame extension (49) inside the intermediate body with bellows in correspondence with stud-bolts (34).
- 7) Insert the spring washers (37) and the elastic washers (36) on the stud-bolts and torque tighten the nuts (35) according to table 6 on page 84.
- 8) Insert in the frame with the intermediate body the packing gland spring (17), the first packing gland washer (14), the packing gland (15), the second packing gland washer (14).
- 9) Tighten the packing gland screw (13) by two revolutions. **Caution! The packing gland screw keeps the packing gland spring compressed; maximum care shall then be taken to prevent the parts located on the spring from coming out suddenly during the assembly operations.**
- 10) Place the gasket (16) into the frame seat (33).
- 11) Insert the previously-assembled frame into the frame extension (49) and onto the upper stem (41).
- 12) Insert washers (46) into screws (45) and the screws into the frame (33).
- 13) Insert the flat washers (46) and the elastic washers (47) on the screws (45) and torque tighten the nuts (48) according to table 6 on page 84.
- 14) Tighten packing gland screw (13) until it is projected by  $\approx 13$  mm from the upper level of intermediate body.
- 15) Fully tighten on the upper stem (41) the nut (12) and the adjustment nut (11).
- 16) Place the previously-assembled servo control on the frame with intermediate body (33).
- 17) Insert the flat washers (26) and the elastic washers (27) on the lower head stud-bolts and torque tighten the nuts (28) according to table 6 on page 84.
- 18) Enter air into the servo control equal to the maximum value provided for by this signal: **Attention! Servo control stem shall move upwards in its stroke.**

- 19) Place precharge adjustment nut (11) in the position kept before valve disassembly to obtain the same calibration, then fasten by nut (12).
- 20) Extract air from servo control: **Attention! Servo control stem shall move downwards until in contact with adjustment nut (11).**
- 21) Join precharge adjustment nut (11) and servo control shaft (10) with junction clamps (30); insert screws (29) and insert washers (31) on them, then tighten the nuts (32).

**Sectional view of SBS/10 ND 65#80 2-way NC valve with bellows**

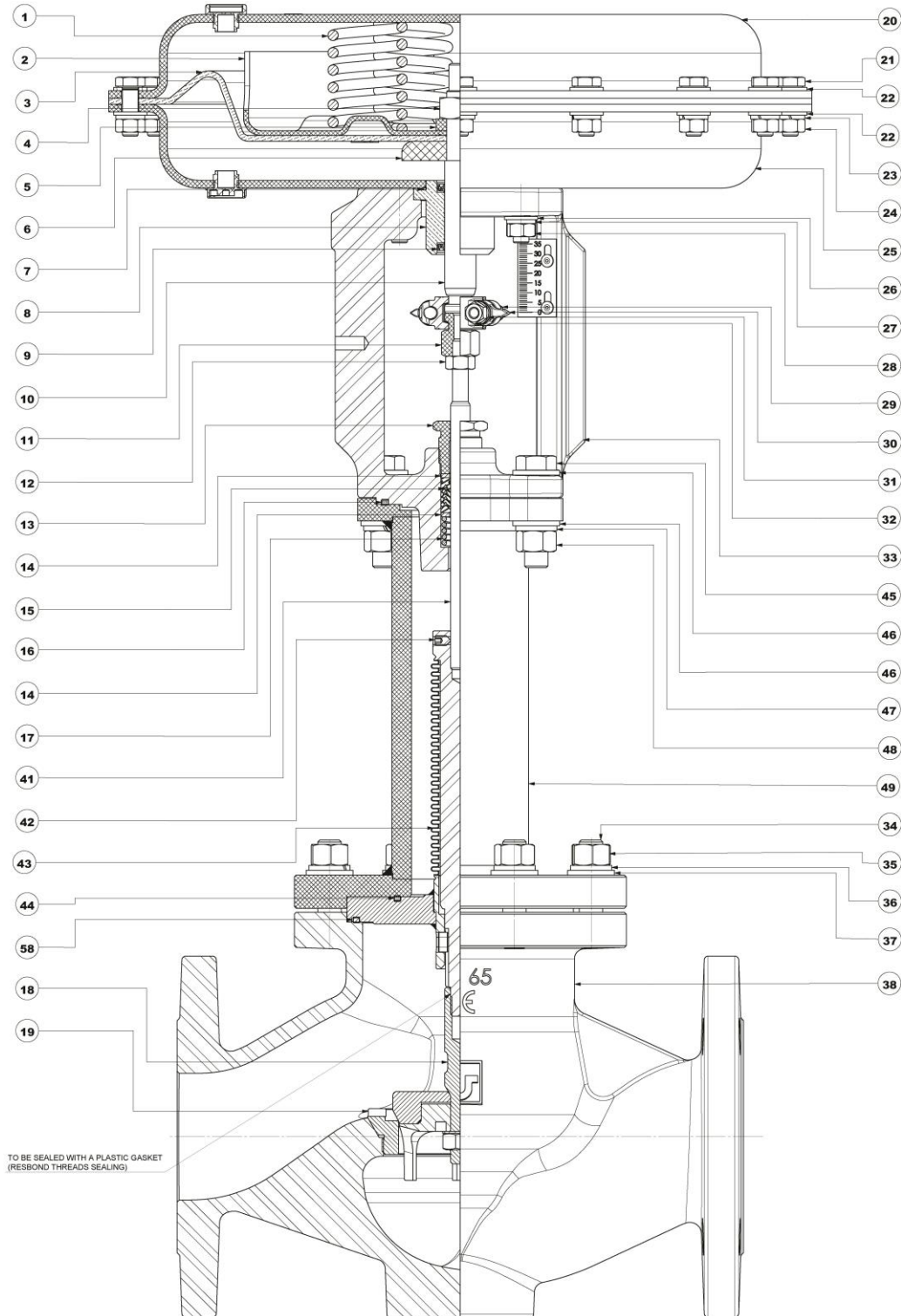

Drawing No. 100673 Rev.:00

## 6.21 Disassembly and assembly instructions for SBS/10 ND 15#50 2-way NO valve with bellows

For disassembly and assembly instructions for SBS/10 ND 15#50 2-way NO valve with bellows refer to Drw. No. 090918 attached hereby.

Assembly and disassembly operations shall be carried out only personnel qualified in in hydraulics and pneumatics, provided with all the necessary work and safety equipment. Before carrying out any operation on systems and valves, get acquainted with operating temperatures and pressures and any other particular conditions, and take the relevant safety measures.

Whenever operations are to be carried out on valves, remove the fluid completely.

**NOTE: Read the procedures thoroughly before starting any operation.**

### 6.21.1 Disassembly

- 1) Enter an air signal into the servo control equal to the maximum value provided for by this signal: **Attention! Servo control shaft shall move downwards.**
- 2) Unscrew the nuts (32), extract the washers (31) and the screws (29), separate the junction clamps (30).
- 3) Extract air from the servo control: **Attention! Servo control shaft shall move upwards.**
- 4) Unscrew the nuts (28), extract the spring washers (27) and the flat washers (26).
- 5) Separate the servo control from frame with intermediate body.
- 6) Untighten adjustment nut (11) and nut (12) carefully making their position.
- 7) Unscrew the nuts (48), extract the spring washers (47), the flat washers (46) and the screws (45).
- 8) Separate the frame with intermediate body from frame extension (49).
- 9) Tighten the packing gland screw (13). **Caution! The packing gland screw (13) keeps the packing gland spring (17) compressed; maximum care shall then be taken to prevent the inner components of frame with intermediate body from coming out suddenly when the packing gland screw (13) is no more kept by the thread.**
- 10) Extract from frame with the intermediate body (33), the first packing gland washer (14), the packing gland (14), the second packing gland washer (15) and the packing gland spring (17).
- 11) Remove the body seal (16) from the frame with intermediate body (33).
- 12) Unscrew the nuts (35), extract the spring washers (36), the flat washers (37) and the frame extension (49).
- 13) Extract the intermediate body with bellows (43) with upper stem (41) and shutter (18) connected with it from the valve body (38).
- 14) Extract the headless screw (42), the with upper stem (41) and shutter (18) from the intermediate body with bellows (43).
- 15) Remove gaskets (44) and (16) from intermediate body with bellows.
- 16) Disassemble the servo control following the procedure described in paragraph 6.28.1.
- 17) Now the valve has been completely disassembled, so that the required components can be replaced.

### 6.21.2 Reassembly

- 1) Reassemble the servo control following the procedure described in paragraph 6.28.2.
- 2) Insert gaskets (16) and (44) into intermediate body with bellows.
- 3) Screw shutter (18) to intermediate body with bellows (43), by using NT 907 TS (RESBOND) threading dope as shown in drawing.
- 4) Tighten the upper stem (41) inside the intermediate body with bellows (43) and fasten by headless screw (42).
- 5) Insert the intermediate body with bellows assembled inside the valve body (38).
- 6) Place the frame extension (49) inside the intermediate body with bellows in correspondence with stud-bolts (34).
- 7) Insert the spring washers (37) and the elastic washers (36) on the stud-bolts and torque tighten the nuts (35) according to table 6 on page 84.
- 8) Insert in the frame with the intermediate body the packing gland spring (17), the first packing gland washer (14), the packing gland (15), the second packing gland washer (14).
- 9) Tighten the packing gland screw (13) by two revolutions. **Caution! The packing gland screw keeps the packing gland spring compressed; maximum care shall then be taken to prevent the parts located on the spring from coming out suddenly during the assembly operations.**
- 10) Place the gasket (16) into the frame seat (33).
- 11) Insert the previously-assembled frame into the frame extension (49) and onto the upper stem (41).
- 12) Insert washers (46) into screws (45) and the screws into the frame (33).
- 13) Insert the flat washers (46) and the elastic washers (47) on the screws (45) and torque tighten the nuts (48) according to table 6 on page 84.
- 14) Tighten packing gland screw (13) until it is projected by  $\approx 13$  mm from the upper level of intermediate body.
- 15) Tighten nut (12) and adjustment nut (11) on the upper stem (41): place adjustment nut in the position kept before valve disassembly to obtain the same calibration, then fasten by nut (12).
- 16) Place the previously-assembled servo control on the frame with intermediate body (33).

- 17) Insert the flat washers (26) and the elastic washers (27) on the lower head stud-bolts and torque tighten the nuts (28) according to table 6 on page 84.
- 18) Insert as much air into servo control as equivalent to maximum value provided for by the signal: **Attention! Servo control stem shall move downwards until in contact with adjustment nut (11).**
- 19) Join precharge adjustment nut (11) and servo control shaft (10) with junction clamps (30), insert screws (29) and insert washers (31) on them, then tighten the nuts (32).
- 20) Extract air from the servo control: **Attention! Servo control shaft shall move upwards in its stroke.**

**Sectional view of SBS/10 ND 15#50 2-way NO valve with bellows**

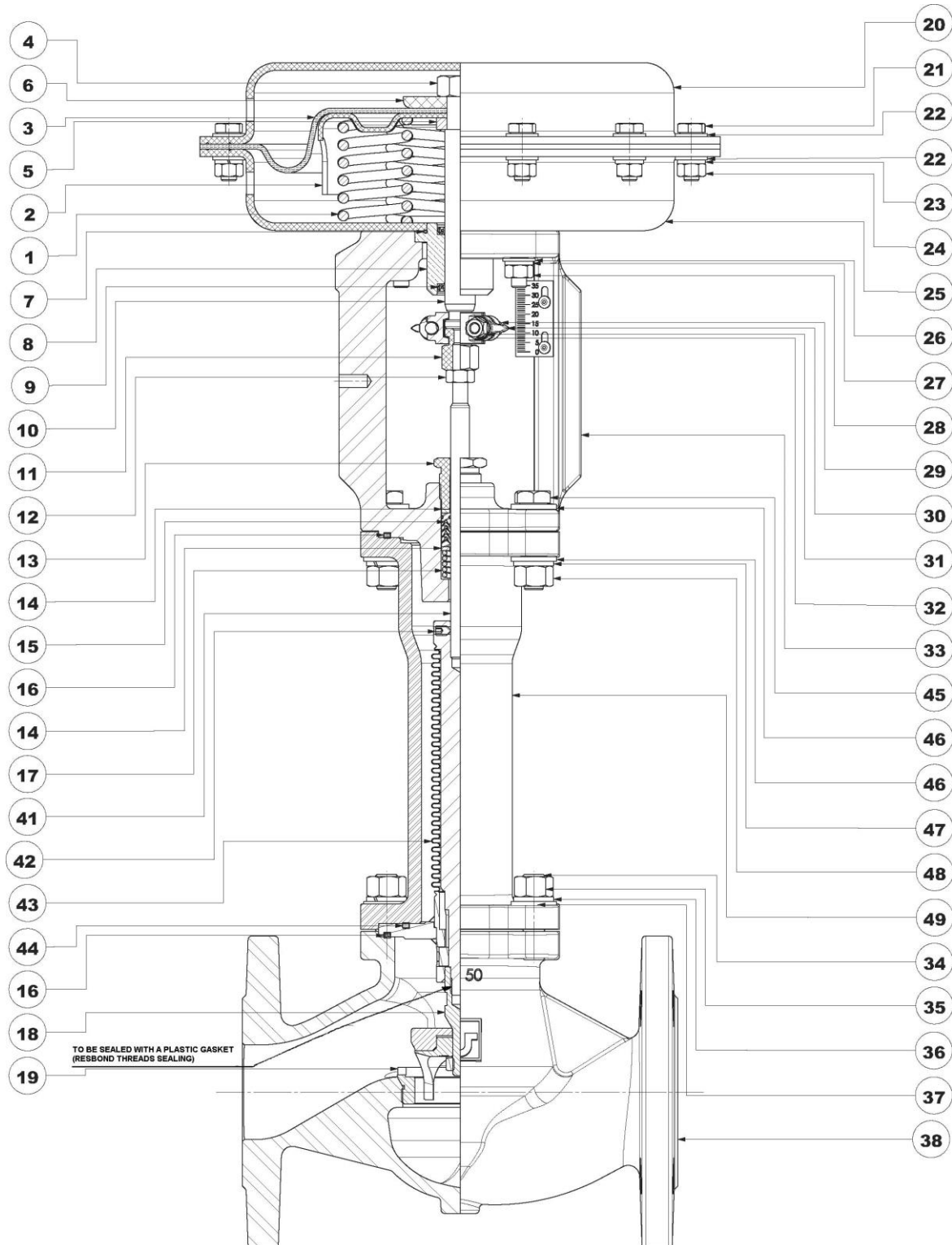

Drawing No. 090918 Rev.:00



## 6.22 Disassembly and assembly instructions for SBS/10 ND 65#80 2-way NO valve with bellows

For disassembly and assembly instructions for SBS/10 ND 65#80 2-way NO valve with bellows refer to Drw. No. 100666 attached hereby.

Assembly and disassembly operations shall be carried out only personnel qualified in in hydraulics and pneumatics, provided with all the necessary work and safety equipment. Before carrying out any operation on systems and valves, get acquainted with operating temperatures and pressures and any other particular conditions, and take the relevant safety measures.

Whenever operations are to be carried out on valves, remove the fluid completely.

**NOTE: Read the procedures thoroughly before starting any operation.**

### 6.22.1 Disassembly

- 1) Enter an air signal into the servo control equal to the maximum value provided for by this signal: **Attention! Servo control shaft shall move downwards.**
- 2) Unscrew the nuts (32), extract the washers (31) and the screws (29), separate the junction clamps (30).
- 3) Extract air from the servo control: **Attention! Servo control shaft shall move upwards.**
- 4) Unscrew the nuts (28), extract the spring washers (27) and the flat washers (26).
- 5) Separate the servo control from frame with intermediate body.
- 6) Untighten adjustment nut (11) and nut (12) carefully making their position.
- 7) Unscrew the nuts (48), extract the spring washers (47), the flat washers (46) and the screws (45).
- 8) Separate the frame with intermediate body from frame extension (49).
- 9) Tighten the packing gland screw (13). **Caution! The packing gland screw (13) keeps the packing gland spring (17) compressed; maximum care shall then be taken to prevent the inner components of frame with intermediate body from coming out suddenly when the packing gland screw (13) is no more kept by the thread.**
- 10) Extract from frame with the intermediate body (33), the first packing gland washer (14), the packing gland (14), the second packing gland washer (15) and the packing gland spring (17).
- 11) Remove the body seal (16) from the frame with intermediate body (33).
- 12) Unscrew the nuts (35), extract the spring washers (36), the flat washers (37) and the frame extension (49).
- 13) Extract the intermediate body with bellows (43) with upper stem (41) and shutter (18) connected with it from the valve body (38).
- 14) Extract the headless screw (42), the with upper stem (41) and shutter (18) from the intermediate body with bellows (43).
- 15) Remove gaskets (44) and (58) from intermediate body with bellows.
- 16) Disassemble the servo control following the procedure described in paragraph 6.28.1.
- 17) Now the valve has been completely disassembled, so that the required components can be replaced.

### 6.22.2 Reassembly

- 1) Reassemble the servo control following the procedure described in paragraph 6.28.2.
- 2) Insert gaskets (58) and (44) into intermediate body with bellows.
- 3) Screw shutter (18) to intermediate body with bellows (43), by using NT 907 TS (RESBOND) threading dope as shown in drawing.
- 4) Tighten the upper stem (41) inside the intermediate body with bellows (43) and fasten by headless screw (42).
- 5) Insert the intermediate body with bellows assembled inside the valve body (38).
- 6) Place the frame extension (49) inside the intermediate body with bellows in correspondence with stud-bolts (34).
- 7) Insert the spring washers (37) and the elastic washers (36) on the stud-bolts and torque tighten the nuts (35) according to table 6 on page 84.
- 8) Insert in the frame with the intermediate body the packing gland spring (17), the first packing gland washer (14), the packing gland (15), the second packing gland washer (14).
- 9) Tighten the packing gland screw (13) by two revolutions. **Caution! The packing gland screw keeps the packing gland spring compressed; maximum care shall then be taken to prevent the parts located on the spring from coming out suddenly during the assembly operations.**
- 10) Place the gasket (16) into the frame seat (33).
- 11) Insert the previously-assembled frame into the frame extension (49) and onto the upper stem (41).
- 12) Insert washers (46) into screws (45) and the screws into the frame (33).
- 13) Insert the flat washers (46) and the elastic washers (47) on the screws (45) and torque tighten the nuts (48) according to table 6 on page 84.
- 14) Tighten packing gland screw (13) until it is projected by  $\approx 13$  mm from the upper level of intermediate body.
- 15) Tighten nut (12) and adjustment nut (11) on the upper stem (41): place adjustment nut in the position kept before valve disassembly to obtain the same calibration, then fasten by nut (12).
- 16) Place the previously-assembled servo control on the frame with intermediate body (33).



- 17) Insert the flat washers (26) and the elastic washers (27) on the lower head stud-bolts and torque tighten the nuts (28) according to table 6 on page 84.
- 18) Insert as much air into servo control as equivalent to maximum value provided for by the signal: **Attention! Servo control stem shall move downwards until in contact with adjustment nut (11).**
- 19) Join precharge adjustment nut (11) and servo control shaft (10) with junction clamps (30), insert screws (29) and insert washers (31) on them, then tighten the nuts (32).
- 20) Extract air from the servo control: **Attention! Servo control shaft shall move upwards in its stroke.**

**Sectional view of SBS/10 ND 65#80 2-way NO valve with bellows**

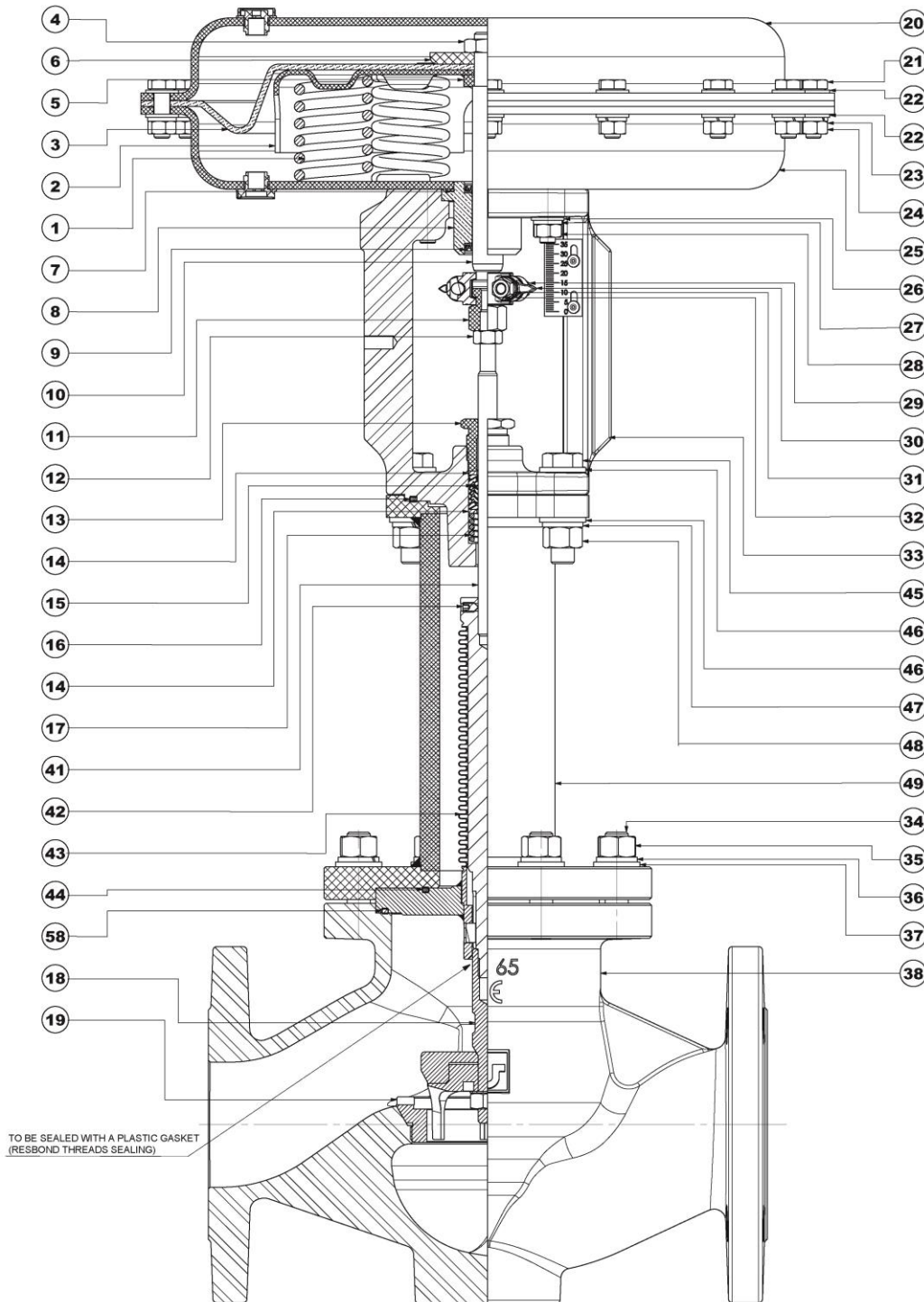

Drawing No. 100666 Rev.:00

## 6.23 Disassembly and assembly instructions for SBS/10 3-way NC mixer valve with bellows

For disassembly and assembly instructions for SBS/10 3-way NC mixer valve with bellows refer to Drw. No. 090919 attached hereby.

Assembly and disassembly operations shall be carried out only personnel qualified in in hydraulics and pneumatics, provided with all the necessary work and safety equipment. Before carrying out any operation on systems and valves, get acquainted with operating temperatures and pressures and any other particular conditions, and take the relevant safety measures.

Whenever operations are to be carried out on valves, remove the fluid completely.

**NOTE: Read the procedures thoroughly before starting any operation.**

### 6.23.1 Disassembly

- 1) Unscrew the nuts (32), extract the washers (31) and the screws (29), separate the junction clamps (30).
- 2) Enter an air signal into the servo control equal to the maximum value provided for by this signal: **Attention! Servo control shaft shall move upwards**
- 3) Untighten adjustment nut (11) and nut (12) carefully making their position.
- 4) Unscrew the nuts (48), extract the spring washers (47), the flat washers (46) and the screws (45).
- 5) Separate the servo control and the frame with intermediate body frame extension (49).
- 6) Remove air from servo control, unscrew the nuts (28), extract the spring washers (27) and the flat washers (26).
- 7) Separate the frame with intermediate body from servo control.
- 8) Untighten the packing gland screw (13). **Caution! The packing gland screw (13) keeps the packing gland spring (17) compressed; maximum care shall then be taken to prevent the inner components of frame with intermediate body from coming out suddenly when the packing gland screw (13) is no more kept by the thread.**
- 9) Extract from frame with the intermediate body (33), the first packing gland washer (14), the packing gland (14), the second packing gland washer (15) and the packing gland spring (17).
- 10) Remove the body seal (16) from the frame with intermediate body (33).
- 11) Unscrew the lower nuts (35), extract the spring washers (36) and the flat washers (37).
- 12) Separate the bottom base (40) from the valve body (38).
- 13) Extract the bottom base gasket (39).
- 14) Untighten the lower seat (19) and the shutter (18) from the intermediate body with bellows (43).
- 15) Unscrew the nuts (35), extract the spring washers (36), the flat washers (37) and the frame extension (49).
- 16) Extract the intermediate body with bellows (43) with upper stem (41) connected with it from the valve body (38).
- 17) Extract the headless screw (42) and the upper stem (41) from the intermediate body with bellows (43).
- 18) Remove gaskets (44) and (16) from intermediate body with bellows.
- 19) Disassemble the servo control following the procedure described in paragraph 6.27.1.
- 20) Now the valve has been completely disassembled, so that the required components can be replaced.

### 6.23.2 Reassembly

- 1) Reassemble the servo control following the procedure described in paragraph 6.27.2.
- 2) Insert gaskets (16) and (44) into intermediate body with bellows.
- 3) Tighten the upper stem (41) inside the intermediate body with bellows (43) and fasten by headless screw (42).
- 4) Insert the intermediate body with bellows assembled inside the valve body (38).
- 5) Place the frame extension (49) inside the intermediate body with bellows in correspondence with stud-bolts (34).
- 6) Insert the spring washers (37) and the elastic washers (36) on the stud-bolts and torque tighten the nuts (35) according to table 6 on page 84.
- 7) Screw shutter (18) to intermediate body with bellows (43) (through valve body bottom), by using NT 907 TS (RESBOND) threading dope as shown in drawing.
- 8) Spread MOTORSIL D (AREXONS) silicone gasket in the contact area between seat and valve body; then, tighten lower seat (19).
- 9) Place the gasket (39) in the bottom base (40).
- 10) Insert the bottom base (40) on the stud-bolts, then insert flat washers (37) and elastic washers (36) and torque tighten the lower nuts (35) according to table 6 on page 84.
- 11) Insert in the frame with the intermediate body the packing gland spring (17), the first packing gland washer (14), the packing gland (15), the second packing gland washer (14).
- 12) Tighten the packing gland screw (13) by two revolutions. **Caution! The packing gland screw keeps the packing gland spring compressed; maximum care shall then be taken to prevent the parts located on the spring from coming out suddenly during the assembly operations.**
- 13) Place the gasket (16) into the frame seat (33).
- 14) Insert the previously-assembled frame into the frame extension (49) and onto the upper stem (41).
- 15) Insert washers (46) into screws (45) and the screws into the frame (33).
- 16) Insert the flat washers (46) and the elastic washers (47) on the screws (45) and torque tighten the nuts (48) according to table 6 on page 84.

- 17) Tighten packing gland screw (13) until it is projected by  $\approx 13$  mm from the upper level of intermediate body.
- 18) Fully tighten on the upper stem (41) the nut (12) and the adjustment nut (11).
- 19) Place the previously-assembled servo control on the frame with intermediate body (33).
- 20) Insert the flat washers (26) and the elastic washers (27) on the lower head stud-bolts and torque tighten the nuts (28) according to table 6 on page 84.
- 21) Enter air into the servo control equal to the maximum value provided for by this signal: **Attention! Servo control stem shall move upwards in its stroke.**
- 22) Place precharge adjustment nut (11) in the position kept before valve disassembly to obtain the same calibration, then fasten by nut (12).
- 23) Extract air from servo control: **Attention! Servo control stem shall move downwards until in contact with adjustment nut (11).**
- 24) Join precharge adjustment nut (11) and servo control shaft (10) with junction clamps (30); insert screws (29) and insert washers (31) on them, then tighten the nuts (32).

### Sectional view of SBS/10 3-way NC mixer valve with bellows

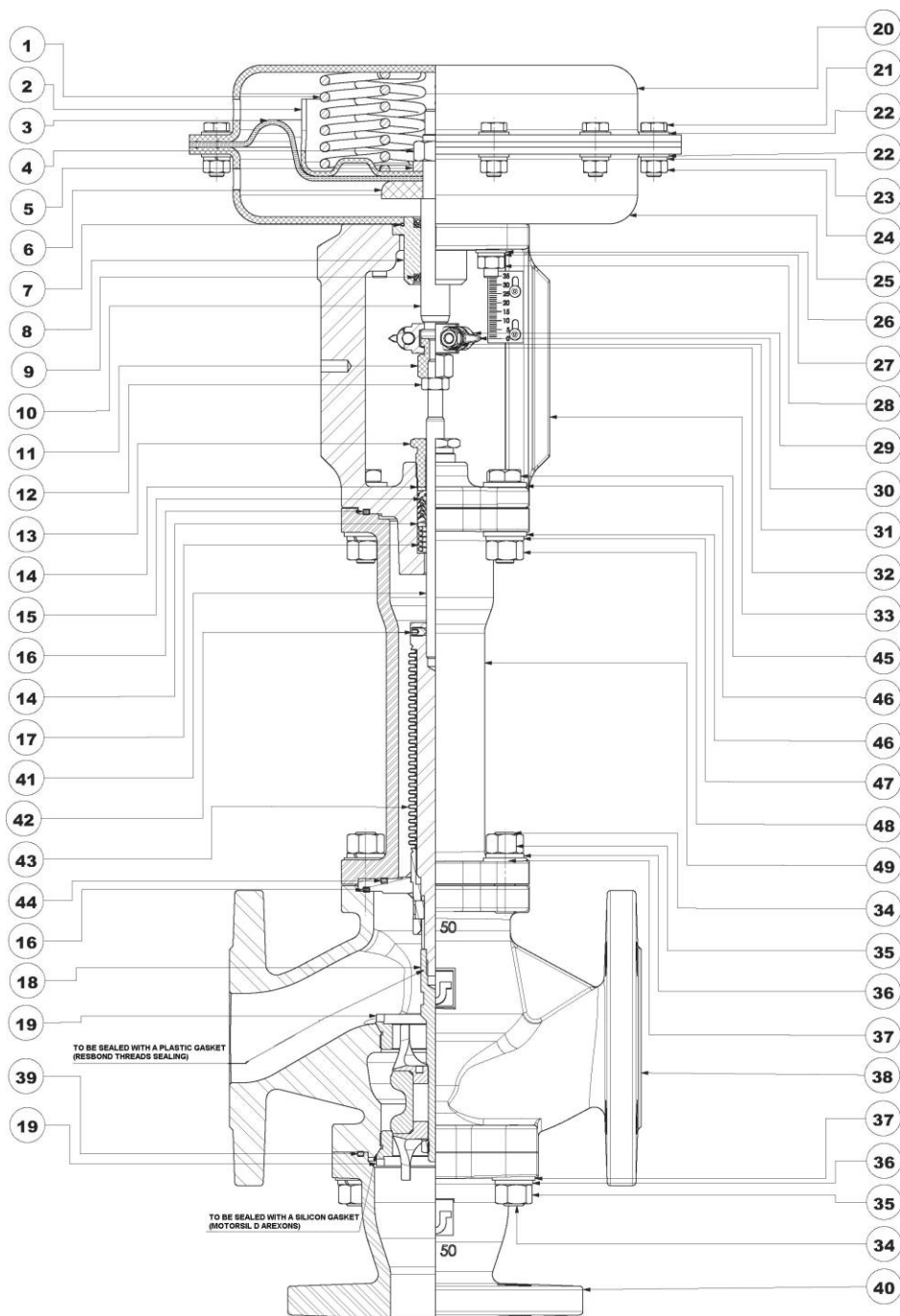

Drawing No. 090919 Rev.:00

## 6.24 Disassembly and assembly instructions for SBS/10 3-way NO mixer valve with bellows

For disassembly and assembly instructions for SBS/10 3-way NO mixer valve with bellows refer to Drw. No. 090920 attached hereby.

Assembly and disassembly operations shall be carried out only personnel qualified in in hydraulics and pneumatics, provided with all the necessary work and safety equipment. Before carrying out any operation on systems and valves, get acquainted with operating temperatures and pressures and any other particular conditions, and take the relevant safety measures.

Whenever operations are to be carried out on valves, remove the fluid completely.

**NOTE: Read the procedures thoroughly before starting any operation.**

### 6.24.1 Disassembly

- 1) Enter an air signal into the servo control equal to the maximum value provided for by this signal: **Attention! Servo control shaft shall move downwards.**
- 2) Unscrew the nuts (32), extract the washers (31) and the screws (29), separate the junction clamps (30).
- 3) Extract air from the servo control: **Attention! Servo control shaft shall move upwards.**
- 4) Unscrew the nuts (28), extract the spring washers (27) and the flat washers (26).
- 5) Separate the servo control from frame with intermediate body.
- 6) Untighten adjustment nut (11) and nut (12) carefully making their position.
- 7) Unscrew the nuts (48), extract the spring washers (47), the flat washers (46) and the screws (45).
- 8) Separate the frame with intermediate body (33) from frame extension (49).
- 9) Tighten the packing gland screw (13). **Caution! The packing gland screw (13) keeps the packing gland spring (17) compressed; maximum care shall then be taken to prevent the inner components of frame with intermediate body from coming out suddenly when the packing gland screw (13) is no more kept by the thread.**
- 10) Extract from frame with the intermediate body (33), the first packing gland washer (14), the packing gland (15), the second packing gland washer (14) and the packing gland spring (17).
- 11) Remove the body seal (16) from the frame with intermediate body (33).
- 12) Unscrew the lower nuts (35), extract the spring washers (36) and the flat washers (37).
- 13) Separate the bottom base (40) from the valve body (38).
- 14) Extract the bottom base gasket (39).
- 15) Untighten the lower seat (19) and the shutter (18) from the intermediate body with bellows (43).
- 16) Unscrew the nuts (35), extract the spring washers (36), the flat washers (37) and the frame extension (49).
- 17) Extract the intermediate body with bellows (43) with upper stem (41) connected with it from the valve body (38).
- 18) Extract the headless screw (42) and the upper stem (41) from the intermediate body with bellows (43).
- 19) Remove gaskets (44) and (16) from intermediate body with bellows.
- 20) Disassemble the servo control following the procedure described in paragraph 6.28.1.
- 21) Now the valve has been completely disassembled, so that the required components can be replaced.

### 6.24.2 Reassembly

- 1) Reassemble the servo control following the procedure described in paragraph 6.28.2.
- 2) Insert gaskets (16) and (44) into intermediate body with bellows.
- 3) Tighten the upper stem (41) inside the intermediate body with bellows (43) and fasten by headless screw (42).
- 4) Insert the intermediate body with bellows assembled inside the valve body (38).
- 5) Place the frame extension (49) inside the intermediate body with bellows in correspondence with stud-bolts (34).
- 6) Insert the spring washers (37) and the elastic washers (36) on the stud-bolts and torque tighten the nuts (35) according to table 6 on page 84.
- 7) Screw shutter (18) to intermediate body with bellows (43) (through valve body bottom), by using NT 907 TS (RESBOND) threading dope as shown in drawing.
- 8) Spread MOTORSIL D (AREXONS) silicone gasket in the contact area between seat and valve body; then, tighten lower seat (19).
- 9) Place the gasket (39) in the bottom base (40).
- 10) Insert the bottom base (40) on the stud-bolts, then insert flat washers (37) and elastic washers (36) and torque tighten the lower nuts (35) according to table 6 on page 84.
- 11) Insert in the frame with the intermediate body the packing gland spring (17), the first packing gland washer (14), the packing gland (15), the second packing gland washer (14).
- 12) Tighten the packing gland screw (13) by two revolutions. **Caution! The packing gland screw keeps the packing gland spring compressed; maximum care shall then be taken to prevent the parts located on the spring from coming out suddenly during the assembly operations.**
- 13) Place the gasket (16) into the frame seat (33).
- 14) Insert the previously-assembled frame into the frame extension (49) and onto the upper stem (41).
- 15) Insert washers (46) into screws (45) and the screws into the frame (33).

- 16) Insert the flat washers (46) and the elastic washers (47) on the screws (45) and torque tighten the nuts (48) according to table 6 on page 84.
- 17) Tighten packing gland screw (13) until it is projected by  $\approx 13$  mm from the upper level of intermediate body.
- 18) Fully tighten on the upper stem (41) the nut (12) and the adjustment nut (11). Place precharge adjustment nut (11) in the position kept before valve disassembly to obtain the same calibration, then fasten by nut (12).
- 19) Place the previously-assembled servo control on the frame with intermediate body (33).
- 20) Insert the flat washers (26) and the elastic washers (27) on the lower head stud-bolts and torque tighten the nuts (28) according to table 6 on page 84.
- 21) Insert as much air into servo control as equivalent to maximum value provided for by the signal: **Attention! Servo control stem shall move downwards until in contact with adjustment nut (11).**
- 22) Join precharge adjustment nut (11) and servo control shaft (10) with junction clamps (30); insert screws (29) and insert washers (31) on them, then tighten the nuts (32).
- 23) Extract air from the servo control: **Attention! Servo control stem shall move upwards.**

### Sectional view of SBS/10 3-way NO mixer valve with bellows

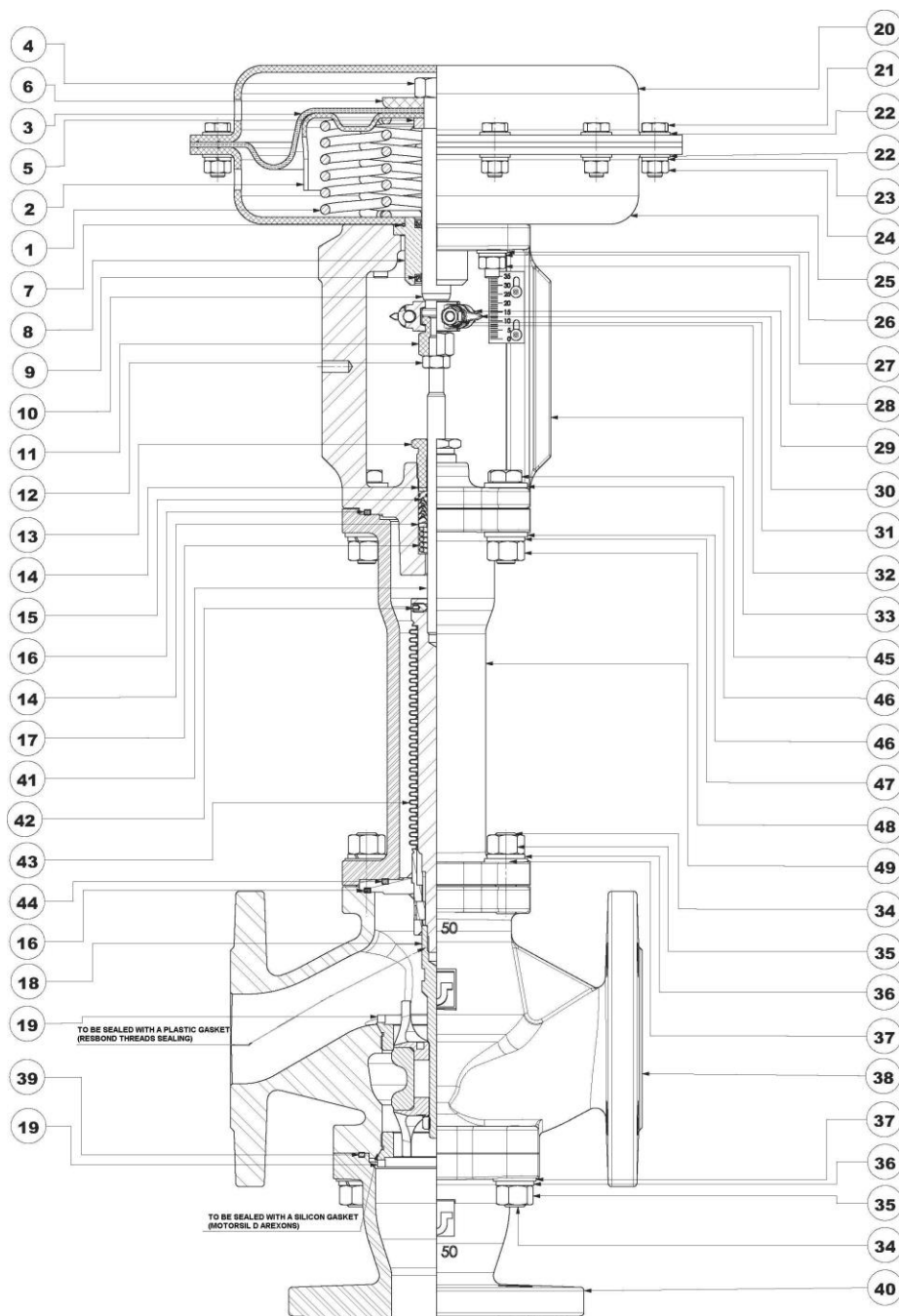

Drawing No. 090920 Rev.:00

## 6.25 Disassembly and assembly instructions for SBS/10 3-way NC deviator valve with bellows

For disassembly and assembly instructions for SBS/10 3-way NC deviator with bellows refer to Drw. No. 090921 attached hereby.

Assembly and disassembly operations shall be carried out only personnel qualified in in hydraulics and pneumatics, provided with all the necessary work and safety equipment. Before carrying out any operation on systems and valves, get acquainted with operating temperatures and pressures and any other particular conditions, and take the relevant safety measures.

Whenever operations are to be carried out on valves, remove the fluid completely.

**NOTE: Read the procedures thoroughly before starting any operation.**

### 6.25.1 Disassembly

- 1) Enter an air signal into the servo control equal to the maximum value provided for by this signal: **Attention! Servo control shaft shall move downwards.**
- 2) Unscrew the nuts (32), extract the washers (31) and the screws (29), separate the junction clamps (30).
- 3) Extract air from the servo control: **Attention! Servo control shaft shall move upwards.**
- 4) Unscrew the nuts (28), extract the spring washers (27) and the flat washers (26).
- 5) Separate the servo control from frame with intermediate body.
- 6) Untighten adjustment nut (11) and nut (12) carefully making their position.
- 7) Unscrew the nuts (48), extract the spring washers (47), the flat washers (46) and the screws (45).
- 8) Separate the frame with intermediate body (33) from frame extension (49).
- 9) Untighten the packing gland screw (13). **Caution! The packing gland screw (13) keeps the packing gland spring (17) compressed; maximum care shall then be taken to prevent the inner components of frame with intermediate body from coming out suddenly when the packing gland screw (13) is no more kept by the thread.**
- 10) Extract from frame with the intermediate body (33), the first packing gland washer (14), the packing gland (14), the second packing gland washer (15) and the packing gland spring (17).
- 11) Remove the body seal (16) from the frame with intermediate body (33).
- 12) Unscrew the lower nuts (35), extract the spring washers (36) and the flat washers (37).
- 13) Separate the bottom base (40) from the valve body (38).
- 14) Extract the bottom base gasket (39).
- 15) Disassemble the shutter (18) following the procedure described in paragraph 5.32.1.
- 16) Unscrew the nuts (35), extract the spring washers (36), the flat washers (37) and the frame extension (49).
- 17) Extract the intermediate body with bellows (43) with upper stem (41) and shutter section (18) connected with it from the valve body (38).
- 18) Extract the headless screw (42) and the upper stem (41) from the intermediate body with bellows (43).
- 19) Complete the shutter (18) disassembly following the procedure described in paragraph 6.32.2.
- 20) Remove gaskets (44) and (16) from intermediate body with bellows.
- 21) Disassemble the servo control following the procedure described in paragraph 6.28.1.
- 22) Now the valve has been completely disassembled, so that the required components can be replaced.

### 6.25.2 Reassembly

- 1) Reassemble the servo control following the procedure described in paragraph 6.28.2.
- 2) Reassemble the shutter following the procedure described in paragraph 6.32.3.
- 3) Insert gaskets (16) and (44) into intermediate body with bellows.
- 4) Tighten the upper stem (41) to the intermediate body with bellows and fasten by headless screw (42).
- 5) Insert the intermediate body with bellows assembled inside the valve body (38).
- 6) Place the frame extension (49) inside the intermediate body with bellows in correspondence with stud-bolts (34).
- 7) Insert the spring washers (37) and the elastic washers (36) on the stud-bolts and torque tighten the nuts (35) according to table 6 on page 84.
- 8) Complete the shutter (18) disassembly operations following the procedure described in paragraph 6.32.4.
- 9) Place the gasket (39) in the bottom base (40).
- 10) Insert the bottom base (40) on the stud-bolts, then insert flat washers (37) and elastic washers (36) and torque tighten the lower nuts (35) according to table 6 on page 84.
- 11) Insert in the frame with the intermediate body the packing gland spring (17), the first packing gland washer (14), the packing gland (15), the second packing gland washer (14).
- 12) Tighten the packing gland screw (13) by two revolutions. **Caution! The packing gland screw keeps the packing gland spring compressed; maximum care shall then be taken to prevent the parts located on the spring from coming out suddenly during the assembly operations.**
- 13) Place the gasket (16) into the frame seat (33).
- 14) Insert the previously-assembled frame into the frame extension (49) and onto the upper stem (41).
- 15) Insert washers (46) into screws (45) and the screws into the frame (33).

- 16) Insert the flat washers (46) and the elastic washers (47) on the screws (45) and torque tighten the nuts (48) according to table 6 on page 84.
- 17) Tighten packing gland screw (13) until it is projected by  $\approx 13$  mm from the upper level of intermediate body.
- 18) Fully tighten on the upper stem (41) the nut (12) and the adjustment nut (11). Place precharge adjustment nut (11) in the position kept before valve disassembly to obtain the same calibration, then fasten by nut (12).
- 19) Place the previously-assembled servo control on the frame with intermediate body (33).
- 20) Insert the flat washers (26) and the elastic washers (27) on the lower head stud-bolts and torque tighten the nuts (28) according to table 6 on page 84.
- 21) Insert as much air into servo control as equivalent to maximum value provided for by the signal: **Attention! Servo control stem shall move downwards until in contact with adjustment nut (11).**
- 22) Join precharge adjustment nut (11) and servo control shaft (10) with junction clamps (30); insert screws (29) and insert washers (31) on them, then tighten the nuts (32).
- 23) Extract air from the servo control: **Attention! Servo control stem shall move upwards.**

### Sectional view of SBS/10 3-way NC deviator valve with bellows

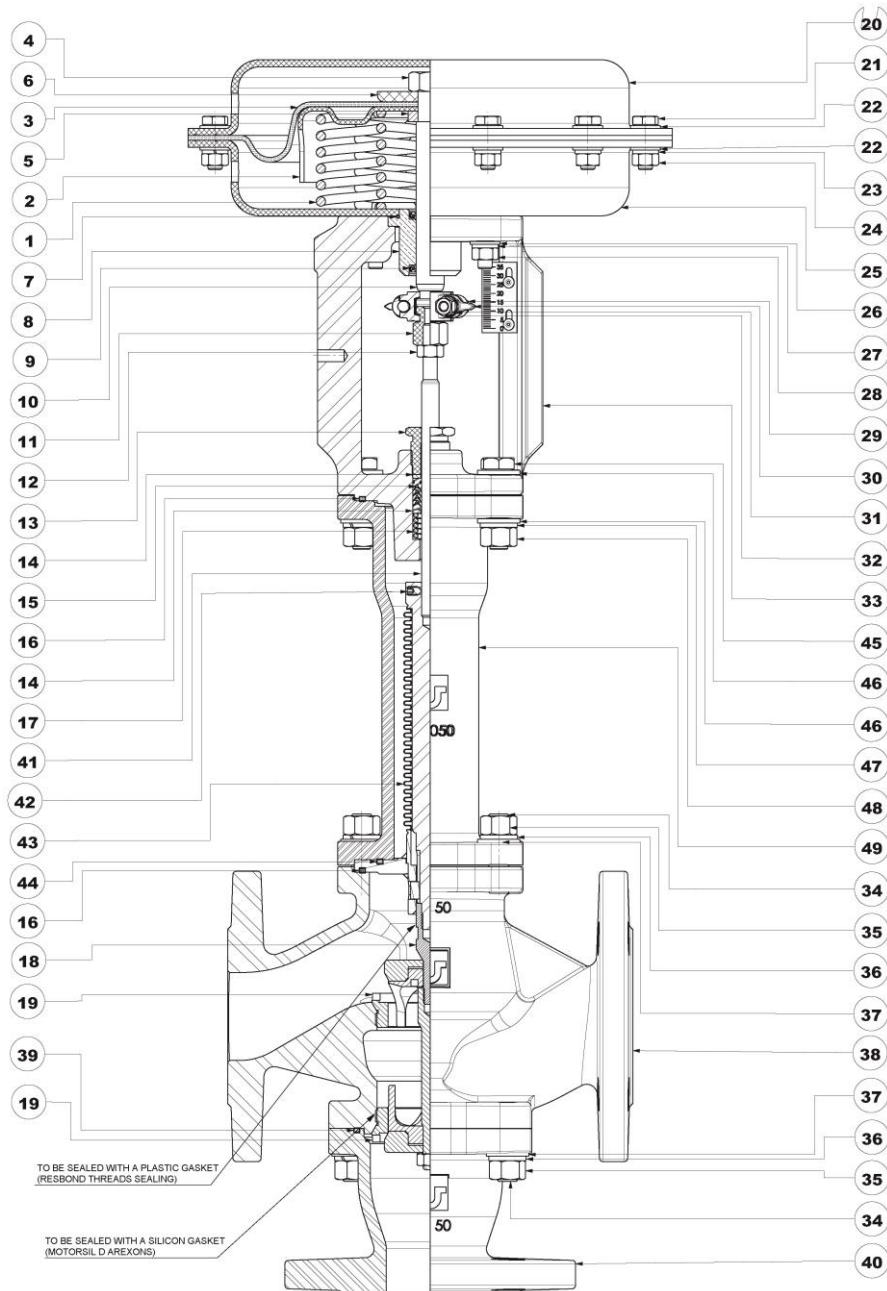

Drawing No. 090921 Rev.:00



## 6.26 Disassembly and assembly instructions for SBS/10 3-way NO deviator valve with bellows

For disassembly and assembly instructions for SBS/10 3-way NO deviator valve with bellows refer to Drw. No. 090922 attached hereby.

Assembly and disassembly operations shall be carried out only personnel qualified in in hydraulics and pneumatics, provided with all the necessary work and safety equipment. Before carrying out any operation on systems and valves, get acquainted with operating temperatures and pressures and any other particular conditions, and take the relevant safety measures.

Whenever operations are to be carried out on valves, remove the fluid completely.

**NOTE: Read the procedures thoroughly before starting any operation.**

### 6.26.1 Disassembly

- 1) Unscrew the nuts (32), extract the washers (31) and the screws (29), separate the junction clamps (30).
- 2) Enter an air signal into the servo control equal to the maximum value provided for by this signal: **Attention! Servo control shaft shall move upwards**
- 3) Unscrew the nuts (48), extract the spring washers (47), the flat washers (46) and the screws (45).
- 4) Untighten adjustment nut (11) and nut (12) carefully making their position.
- 5) Separate the servo control and the frame with intermediate body frame extension (49).
- 6) Extract air from the servo control: **Attention! Servo control shaft shall move downwards.**
- 7) Unscrew the nuts (28), extract the spring washers (27) and the flat washers (26).
- 8) Separate the servo control from frame with intermediate body.
- 9) Untighten the packing gland screw (13). **Caution! The packing gland screw (13) keeps the packing gland spring (17) compressed; maximum care shall then be taken to prevent the inner components of frame with intermediate body from coming out suddenly when the packing gland screw (13) is no more kept by the thread.**
- 10) Extract from frame with the intermediate body (33), the first packing gland washer (14), the packing gland (14), the second packing gland washer (15) and the packing gland spring (17).
- 11) Remove the body seal (16) from the frame with intermediate body (33).
- 12) Unscrew the lower nuts (35), extract the spring washers (36) and the flat washers (37).
- 13) Separate the bottom base (40) from the valve body (38).
- 14) Extract the bottom base gasket (39).
- 15) Disassemble the shutter (18) following the procedure described in paragraph 6.32.1.
- 16) Unscrew the nuts (35), extract the spring washers (36), the flat washers (37) and the frame extension (49).
- 17) Extract the intermediate body with bellows (43) with upper stem (41) and shutter section (18) connected with it from the valve body (38).
- 18) Extract the headless screw (42) and the upper stem (41) from the intermediate body with bellows (43).
- 19) Untighten the shutter stem (18) from the intermediate body (43).
- 20) Complete the shutter (18) disassembly following the procedure described in paragraph 6.32.2.
- 21) Remove gaskets (44) and (16) from intermediate body with bellows.
- 22) Disassemble the servo control following the procedure described in paragraph 6.27.1.
- 23) Now the valve has been completely disassembled, so that the required components can be replaced.

### 6.26.2 Reassembly

- 1) Reassemble the servo control following the procedure described in paragraph 6.27.2.
- 2) Reassemble the shutter following the procedure described in paragraph 6.32.3.
- 3) Insert gaskets (16) and (44) into intermediate body with bellows.
- 4) Tighten the upper stem (41) and fasten by headless screw (42).
- 5) Insert the intermediate body with bellows assembled inside the valve body (38).
- 6) Place the frame extension (49) inside the intermediate body with bellows in correspondence with stud-bolts (34).
- 7) Insert the spring washers (37) and the elastic washers (36) on the stud-bolts and torque tighten the nuts (35) according to table 6 on page 82.
- 8) Complete the shutter (18) disassembly operations following the procedure described in paragraph 6.32.4.
- 9) Place the gasket (39) in the bottom base (40).
- 10) Insert the bottom base (40) on the stud-bolts, then insert flat washers (37) and elastic washers (36) and torque tighten the lower nuts (35) according to table 6 on page 84.
- 11) Insert in the frame with the intermediate body the packing gland spring (17), the first packing gland washer (14), the packing gland (15), the second packing gland washer (14).
- 12) Tighten the packing gland screw (13) by two revolutions. **Caution! The packing gland screw keeps the packing gland spring compressed; maximum care shall then be taken to prevent the parts located on the spring from coming out suddenly during the assembly operations.**
- 13) Place the gasket (16) into the frame seat (33).
- 14) Insert the previously-assembled frame into the frame extension (49) and onto the upper stem (41).



- 15) Insert washers (46) into screws (45) and the screws into the frame (33).
- 16) Insert the flat washers (46) and the elastic washers (47) on the screws (45) and torque tighten the nuts (48) according to table 6 on page 84
- 17) Tighten packing gland screw (13) until it is projected by  $\approx 13$  mm from the upper level of intermediate body.
- 18) Fully tighten on the upper stem (41) the nut (12) and the adjustment nut (11).
- 19) Place the previously-assembled servo control on the frame with intermediate body (33).
- 20) Insert the flat washers (26) and the elastic washers (27) on the lower head stud-bolts and torque tighten the nuts (28) according to table 6 on page 84.
- 21) Enter air into the servo control equal to the maximum value provided for by this signal: **Attention! Servo control stem shall move upwards.**
- 22) Place precharge adjustment nut (11) in the position kept before valve disassembly to obtain the same calibration, then fasten by nut (12).
- 23) Blow air out of the servo control. **Attention! Servo control stem shall move downwards until in contact with adjustment nut (11).**
- 24) Join precharge adjustment nut (11) and servo control shaft (10) with junction clamps (30); insert screws (29) and insert washers (31) on them, then tighten the nuts (32).

### Sectional view of SBS/10 3-way NO deviator valve with bellows

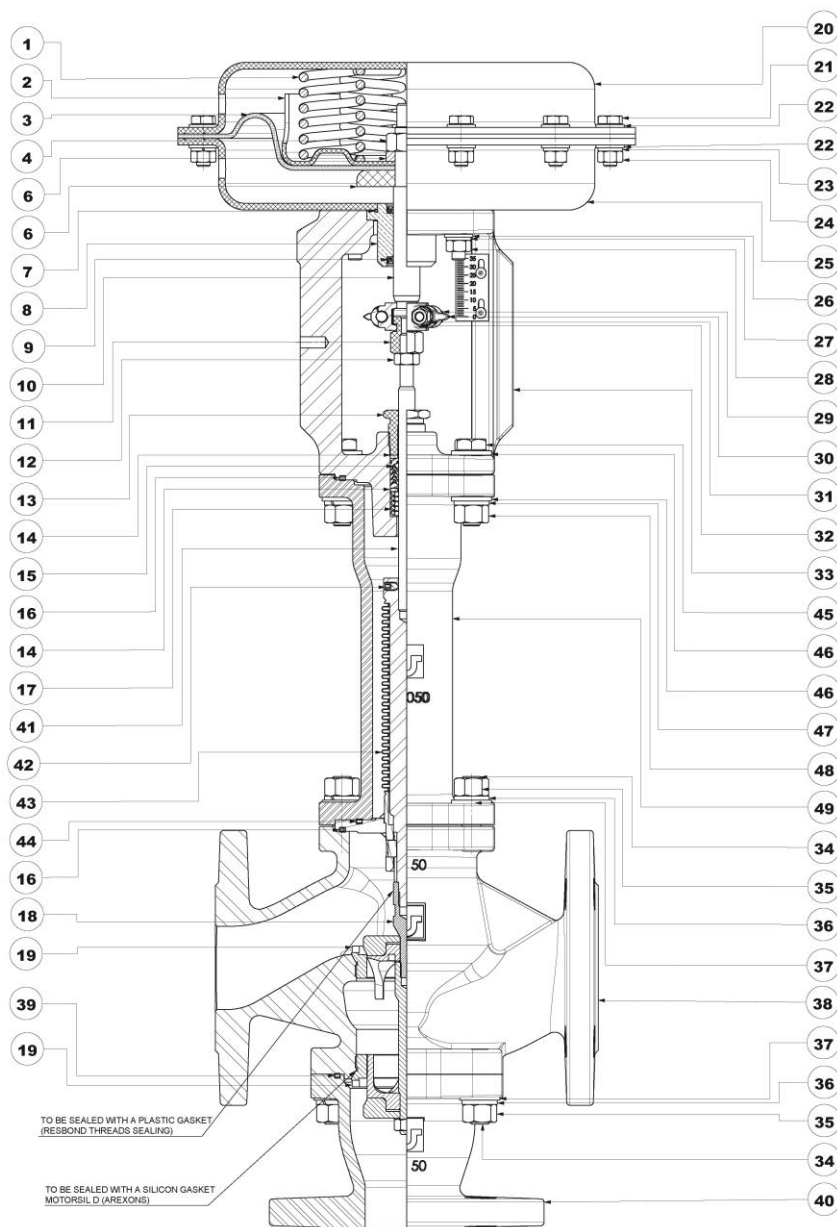

Drawing No. 090922 Rev.:00

## 6.27 Disassembly and assembly instructions for SBS/10 NC servo control

For disassembly and assembly instructions for N.C. servo control for SBS/10 to Drw. No. 090264 attached hereby.

Assembly and disassembly operations shall be carried out only personnel qualified in in hydraulics and pneumatics, provided with all the necessary work and safety equipment. Before carrying out any operation on systems and valves, get acquainted with operating temperatures and pressures and any other particular conditions, and take the relevant safety measures.

Whenever operations are to be carried out on valves, remove the fluid completely.

**NOTE: Read the procedures thoroughly before starting any operation.**

### 6.27.1 Disassembly

- 1) Extract jig bushing (8). Remove BA (9) and OR gasket (7) from it.
- 2) Untighten screws (21) and separate from nuts (24), from flat washers (23) and from elastic washers (22).
- 3) **Attention! Compressed springs are included inside the servo control:** use a suitable equipment to prevent sudden separation of two servo control heads when all screws are untightened (21).
- 4) Remove the upper head (20).
- 5) Extract servo control springs (1).
- 6) Extract the lower head (25) from servo control shaft (10).
- 7) Lock the servo control shaft between soft cheeks (10), then unscrew the nut (4).
- 8) Extract the servo control shaft (10) from spacer ring washer(5), spring-holding plate (2), membrane (3) and diaphragm counter-disc (6).
- 9) Now the servo control has been completely disassembled, so that the required components can be replaced.

### 6.27.2 Reassembly

- 1) Fasten the servo control shaft (10) between soft jaws, insert on it diaphragm counter-disc (6), membrane (3), spring-holding plate (2) and spacer ring washer (5).
- 2) Tighten and punch hexagonal nut (4).
- 3) Insert the lower head (25) into servo control shaft assembled.
- 4) Place membrane (2) so that its screw holes correspond with lower head screw holes.
- 5) Insert springs (1) into spring-holding plate (3), by placing them on centring bosses located on spring-holding plate.
- 6) Place upper head (20) so that air holes of both heads are on the same vertical line and screw holes correspond with membrane and lower head screw holes.
- 7) Using proper instruments, press the springs go get the two heads closer. **Attention! Ensure that two heads cannot suddenly separate before being fastened with proper screws.**
- 8) Insert the flat washers (22) in the screws (21), insert screws (21) into upper head holes (20), insert flat washers (22) and elastic washers 23) into screws (21) and torque tighten the hexagonal nuts (24) according to table 6 on page 82.
- 9) Insert BA (9) and OR gasket (7) into jig bushing (8).
- 10) Insert jig bushing assembled (8) on servo control shaft (10) and lower head (25).
- 11) Now, servo control is completely assembled and can be re-located on valve frame.

**Sectional view of SBS/10 2-way NC valve**

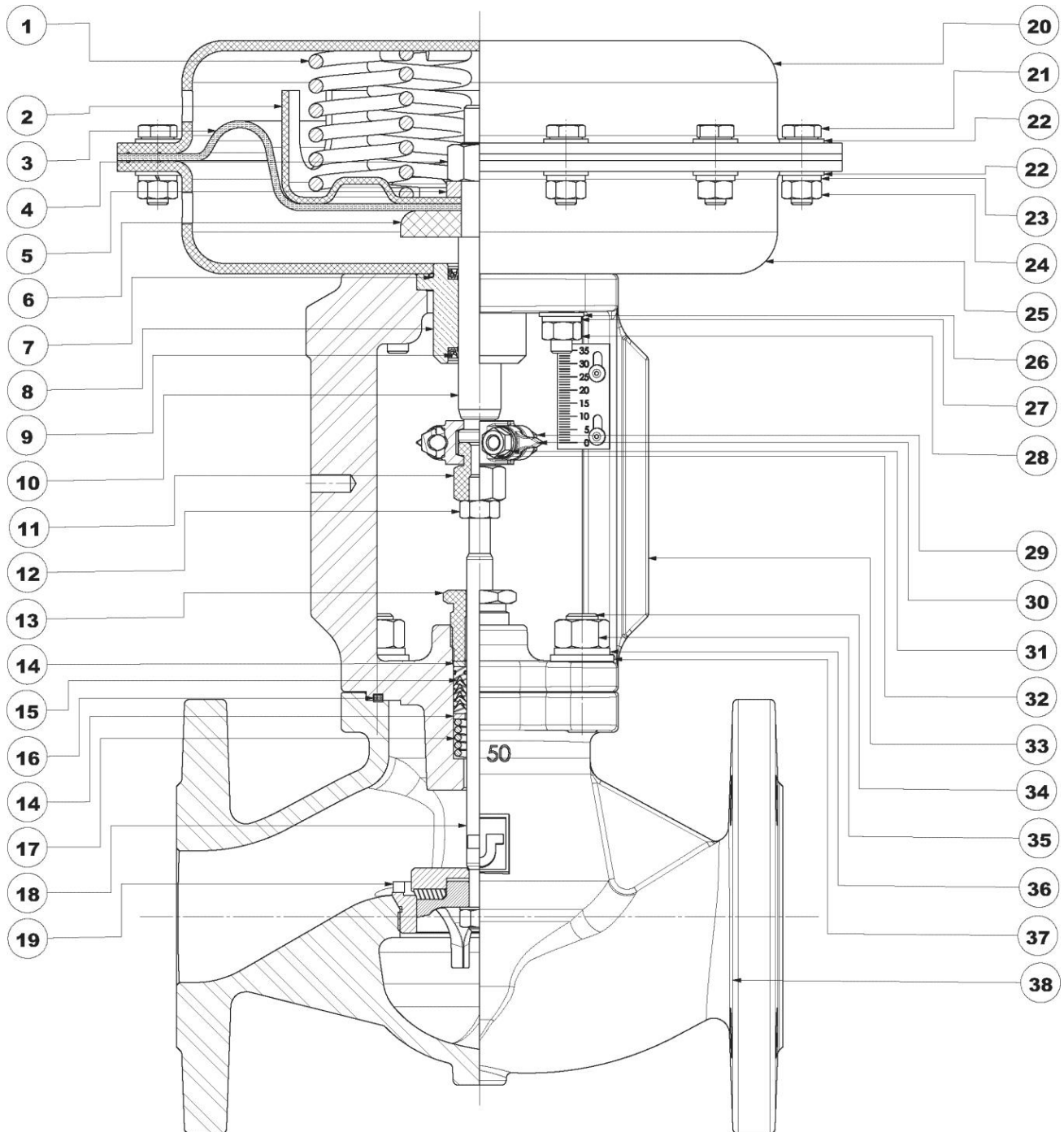

Drawing No. 090264 Rev.:00

## 6.28 Disassembly and assembly instructions for SBS/10 NO servo control

For disassembly and assembly instructions for N.O. servo control for SBS/10 to Drw. No. 090265 attached hereby. Assembly and disassembly operations shall be carried out only personnel qualified in in hydraulics and pneumatics, provided with all the necessary work and safety equipment. Before carrying out any operation on systems and valves, get acquainted with operating temperatures and pressures and any other particular conditions, and take the relevant safety measures.

Whenever operations are to be carried out on valves, remove the fluid completely.

**NOTE: Read the procedures thoroughly before starting any operation.**

### 6.28.1 Disassembly

- 1) Extract jig bushing (8). Remove BA (9) and OR gasket (7) from it.
- 2) Untighten screws (21) and separate from nuts (24), from flat washers (23) and from elastic washers (22).
- 3) **Attention! Compressed springs are included inside the servo control:** use a suitable equipment to prevent sudden separation of two servo control heads when all screws are untightened (21).
- 4) Remove the upper head (20).
- 5) Extract the lower head (25) from servo control shaft (10).
- 6) Extract the springs (1) from lower head (25).
- 7) Lock the servo control shaft between soft jaws and unscrew the nut (4), extract diaphragm counterdisc (6).  
Note: 200 diameter servo control has no nut (4), but the same diaphragm counterdisc works like a closing nut.
- 8) Extract membrane (3), spring-holding plate (2) and spacer (5) from servo control shaft (10).
- 9) Now the servo control has been completely disassembled, so that the required components can be replaced.

### 6.28.2 Reassembly

- 1) Fasten the servo control shaft (10) between soft jaws, insert on it spacer (5), spring-holding plate (2), membrane (3) and diaphragm counter-disc (6).
- 2) Tighten and punch hexagonal nut (4). 200 diameter servo control has no nut (4), but the same diaphragm counterdisc (6) works like a closing nut.
- 3) Place servo control shaft assembled on the upper head (20).
- 4) Place membrane so that its screw holes correspond with upper head screw holes.
- 5) Insert springs (1) into spring-holding plate (2), by placing them on centring bosses located on plate.
- 6) Place lower head (25) so that air holes of both heads are on the same vertical line and screw holes correspond with membrane and upper head screw holes.
- 7) Using proper instruments, press the springs go get the two heads closer. **Attention! Ensure that two heads cannot suddenly separate before being fastened with screws (21).**
- 8) Insert the flat washers (22) in the screws (21), insert screws (21) into upper head holes (20), insert flat washers (22) and elastic washers 23) into screws (21) and torque tighten the hexagonal nuts (24) according to table 6 on page 84.
- 9) Insert BA (9) and OR gasket (7) into jig bushing (8).
- 10) Insert jig bushing assembled (8) on servo control shaft (10) and lower head (25).
- 11) Now, servo control is completely assembled and can be re-located on valve frame.

**Sectional view of SBS/10 2-way NO valve**

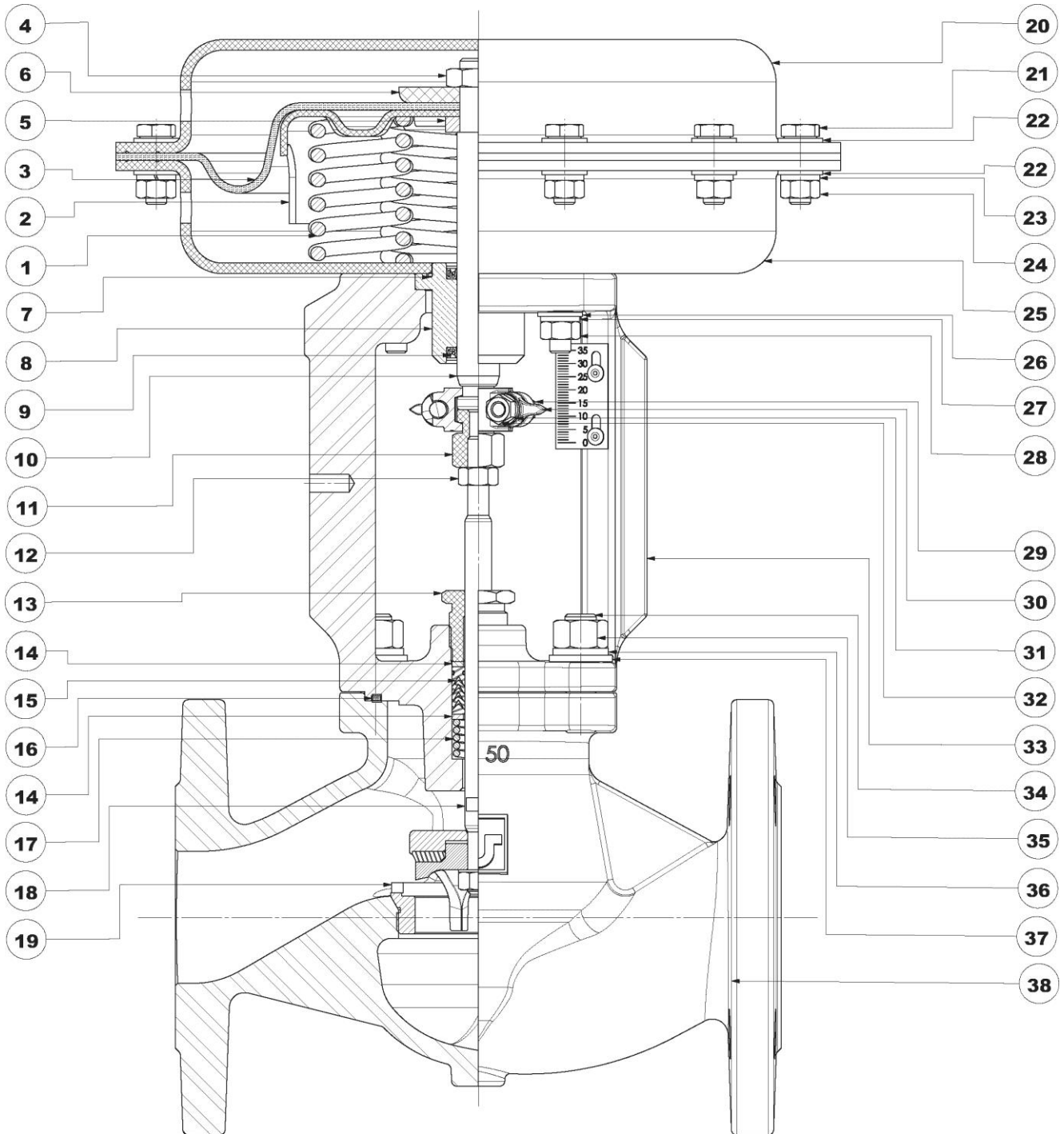

Drawing No. 090265 Rev.:00

## 6.29 Instructions for disassembly, gasket replacement, reassembly of SBS/10 2-way T.P.K. shutters

For the disassembly and assembly operations of the valves, refer to annexed Dwg No. 090189 attached hereby.

Assembly and disassembly operations shall be carried out by qualified personnel only, equipped with all the work and safety tools.

**NOTE: Read the procedures thoroughly before starting any operation.**

### 6.29.1 Disassembly

- 1) Lock the shutter stem (18-A) to untighten the nut (18-E) or for ND 15 remove elastic plug (18-G).
- 2) Extract safety washer (18-D), jig (18-F), insert (18-C) and insert-holder (18-B).

### 6.29.2 Assembly

- 1) Spread MOTORSIL D (AREXONS) silicone gasket in insert holder (18-B) as shown in drawing.
- 2) Insert the shutter stem (18-A) into insert holder (18-B).
- 3) Place insert (18-C) and jig (18-F) into insert holder (18-B).
- 4) Insert the safety washer (18-D) into shutter stem (18-A).
- 5) Spread NT 907 TS (RESBOND) threading dope on shutter stem threading (18-A) as shown in drawing, then torque tighten the hexagonal nut (18-E) as specified in table 6 page 84. For ND 15 insert elastic plug (18-G)
- 6) Punch nut as shown in drawing and let the shutter rest for at least 24 hours so that dopes can dry.

### 6.29.3 T.P. 2-way shutter diagram

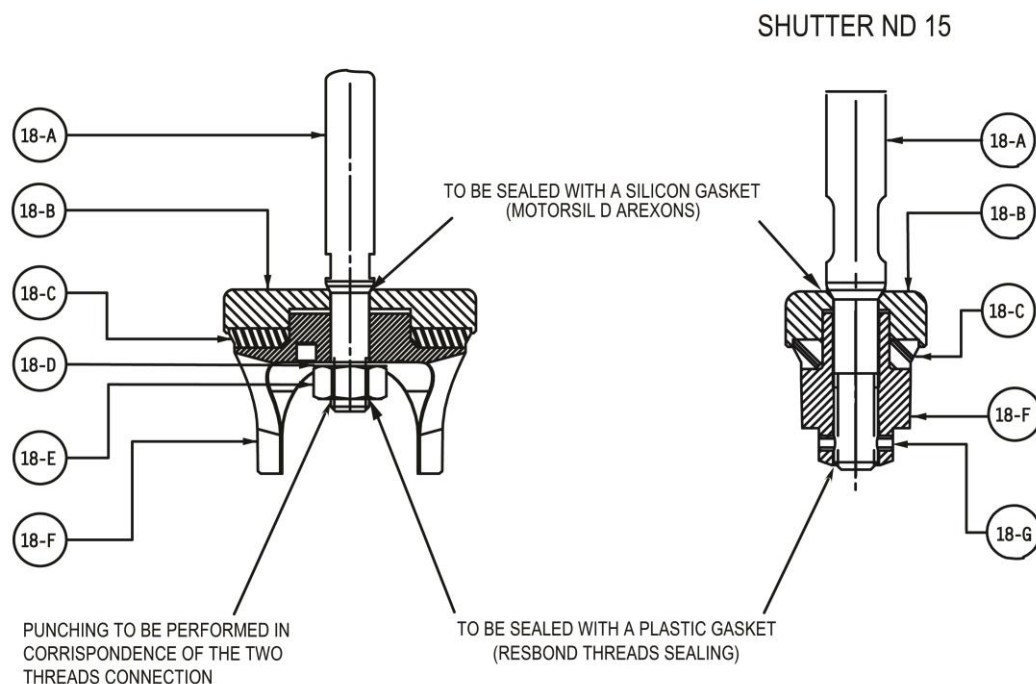

Drawing No. 090189 Rev.:01

## 6.30 Instructions for disassembly, gasket replacement, reassembly of SBS/10 3-way T.P.K. mixer

For the disassembly and assembly operations of the valves, refer to Dwg No. 090190 attached hereby. Assembly and disassembly operations shall be carried out by qualified personnel only, equipped with all the work and safety tools.

**NOTE: Read the procedures thoroughly before starting any operation.**

### 6.30.1 Disassembly

- 1) Lock the shutter stem (18-A) to untighten the nut (18-E) or for ND 15 remove elastic plug (18-G).
- 2) Extract safety washer (18-D), first jig (18-F), first insert (18-C), insert-holder (18-B), second insert (18-C), second jig (18-F).

### 6.30.2 Assembly

- 1) Spread MOTORSIL D (AREXONS) silicone gasket in upper jig (18-F) as shown in drawing.
- 2) Insert the shutter stem (18-A) into upper jig (18-F).
- 3) Insert first insert (18-C), insert-holder (18-B), second insert (18-C), second jig (18-F) on the jig (18-F).
- 4) Insert the safety washer (18-D) into shutter stem (18-A).
- 5) Spread NT 907 TS (RESBOND) threading dope on shutter stem threading (18-A) as shown in drawing, then torque tighten the hexagonal nut (18-E) as specified in table 6 page 84. For ND 15 insert elastic plug (18-G).
- 6) Punch nut as shown in drawing and let the shutter rest for at least 24 hours so that dopes can dry.

### 6.30.3 T.P. 3-way mixer shutter diagram

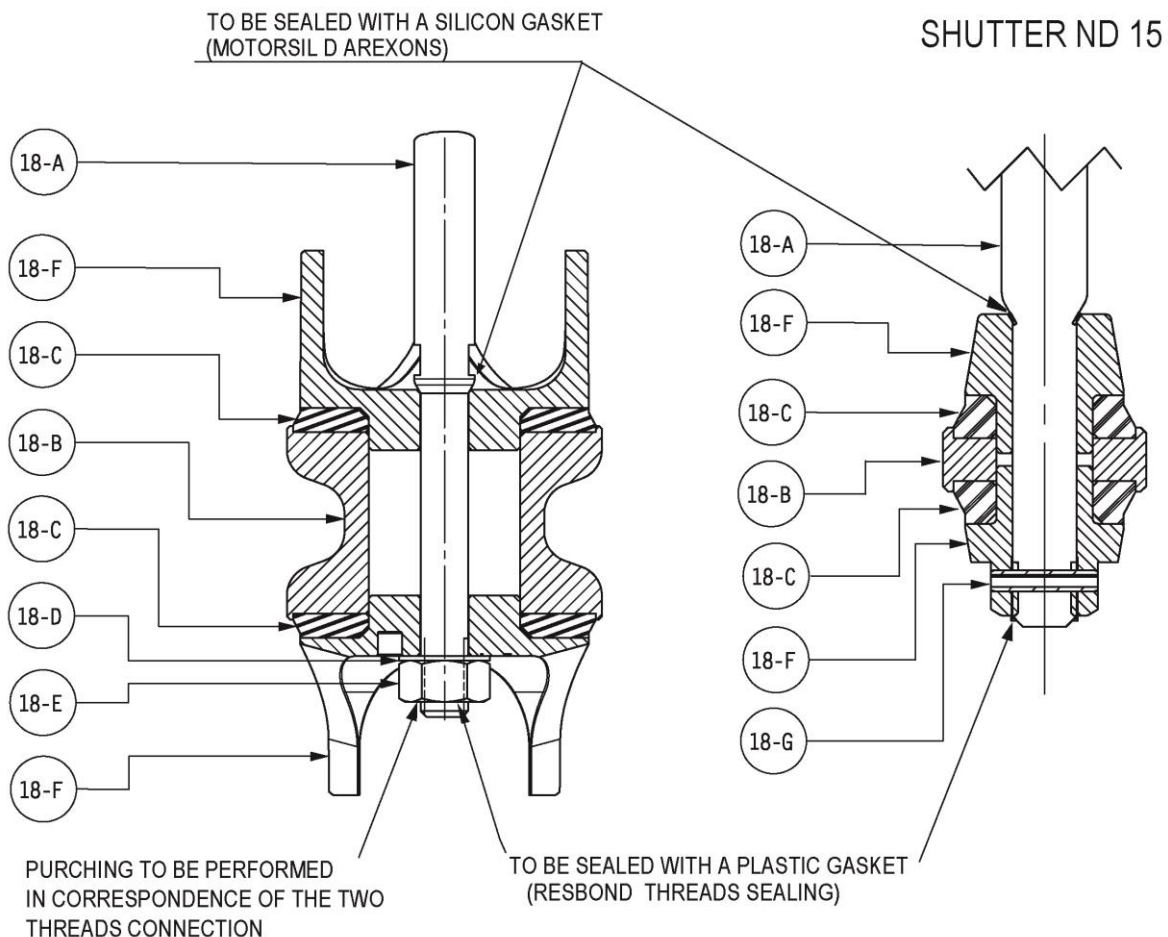

Drawing No. 090190 Rev.:01



## 6.31 Instructions for disassembly, gasket replacement, reassembly of shutters for SBS/10 3-way T.PK. deviator

For the disassembly and assembly operations of the valves, refer to annexed Dwg No. 090915 attached hereby.

Assembly and disassembly operations shall be carried out by qualified personnel only, equipped with all the work and safety tools.

**NOTE: Read the procedures thoroughly before starting any operation.**

### 6.31.1 Disassembly

- 1) Lock the shutter stem (18-A) to untighten the nut (18-E).
- 2) Extract the first safety washer (18-D), the first insert holder (18-B), the first insert (18-C) and the first jig (18-F).
- 3) Extract the shutter from the valve body.
- 4) Lock the shutter stem (18-A), unscrew the setscrews (18-G), unscrew the stem (18-H).
- 5) Extract the second jig (18-F), the second insert (18-C) and the second insert-holder (18-B).

### 6.31.2 Assembly

- 1) Spread MOTORSIL D (AREXONS) silicone gasket in the first insert holder (18-B) as shown in drawing.
- 2) Insert the shutter stem (18-A) into the first insert holder (18-B).
- 3) Place the first insert (18-C) and the first jig (18-F) into the first insert holder (18-B).
- 4) Spread NT 907 TS (RESBOND) threading dope on shutter stem threading (18-A) as shown in drawing, then torque tighten the stem (18-H) as specified in table 6 page 84, tighten the setscrew (18-G) .
- 5) Insert the shutter assembled from the valve body.
- 6) Spread MOTORSIL D (AREXONS) silicone gasket in the second jig (18-F) as shown in drawing.
- 7) Insert the second jig (18-F) onto shutter stem (18-H).
- 8) Place the second insert (18-C) and the insert holder (18-B) into the second jig (18-F).
- 9) Insert the safety washer (18-D) into shutter stem (18-H).
- 10) Spread NT 907 TS (RESBOND) threading dope on shutter stem threading (18-G) as shown in drawing, then torque tighten the hexagonal nut (18-E) as specified in table 6 page 84.
- 11) Punch nut as shown in drawing and let the shutter rest for at least 24 hours so that dopes can dry.

### 6.31.3 T.P. 3-way deviator shutter diagram

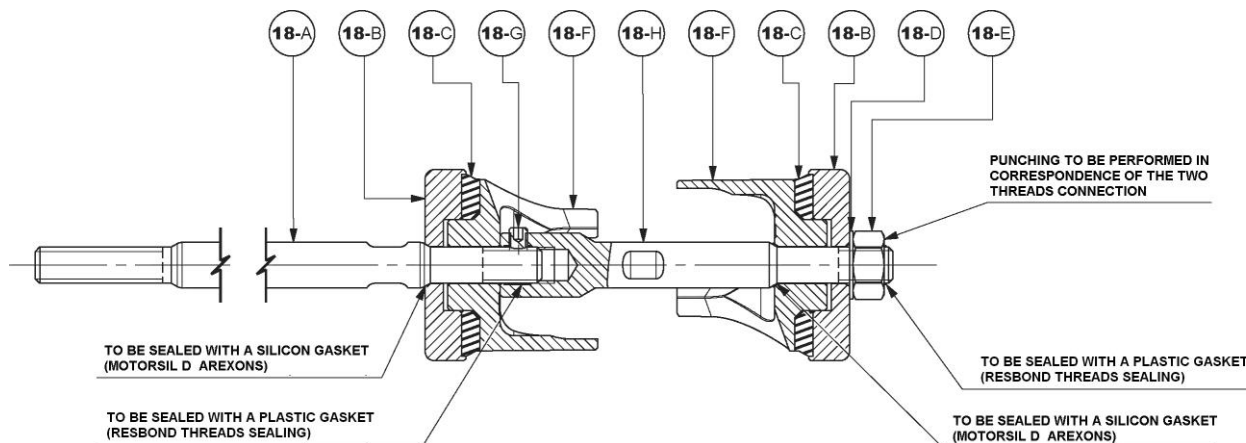

Drawing No. 090915 Rev.:01



## 6.32 Instructions for disassembly, gasket replacement, reassembly of shutters for SBS/10 3-way deviator

For the disassembly and assembly operations of the valves, refer to annexed Dwg No. 090939 attached hereby.

Assembly and disassembly operations shall be carried out by qualified personnel only, equipped with all the work and safety tools.

**NOTE: Read the procedures thoroughly before starting any operation.**

### 6.32.1 Disassembly: 1st part

- 1) Unscrew the nut (18-E).
- 2) Extract the safety washer (18-D), the first metal insert (18-B), the first jig (18-F).

### 6.32.2 Disassembly: 2nd part

- 1) Extract the intermediate body with bellows from valve body (38), untighten shutter stem (18-A) from intermediate body with bellows (43).
- 2) Lock the shutter stem (18-A) unscrew the setscrews (18-G), unscrew the stem (18-H).
- 3) Extract the second jig (18-F), the second metal insert (18-B).

### 6.32.3 Assembly: 1st part

- 1) Spread MOTORSIL D (AREXONS) silicone gasket in the first metal insert (18-B) as shown in drawing.
- 2) Insert the shutter stem (18-A) into the first metal insert (18-B).
- 3) Place the first jig (18-F) into the first metal insert (18-B).
- 4) Spread NT 907 TS (RESBOND) threading dope on shutter stem threading (18-A) as shown in drawing, then torque tighten the stem (18-H) as specified in table 6 page 84.
- 5) Tighten the setscrew (18-G).
- 6) Spread NT 907 TS (RESBOND) threading dope on intermediate body stem threading (43) and tighten shutter stem (18-A).

### 6.32.4 Assembly: 2nd part

- 1) After inserting the intermediate body with bellows (43) into valve body, spread MOTORSIL D (AREXONS) silicone gasket in the second jig (18-F) as shown in drawing.
- 2) Insert the second jig (18-F) onto shutter stem (18-H).
- 3) Place the second metal insert (18-B) into the second jig (18-F).
- 4) Insert the safety washer (18-D) into shutter stem (18-H).
- 5) Spread NT 907 TS (RESBOND) threading dope on shutter stem threading (18-H) as shown in drawing, then torque tighten the hexagonal nut (18-E) as specified in table 6 page 84.
- 6) Punch nut as shown in drawing and let the shutter rest for at least 24 hours so that dopes can dry.

### 6.32.5 3-way deviator bellow shutter diagram

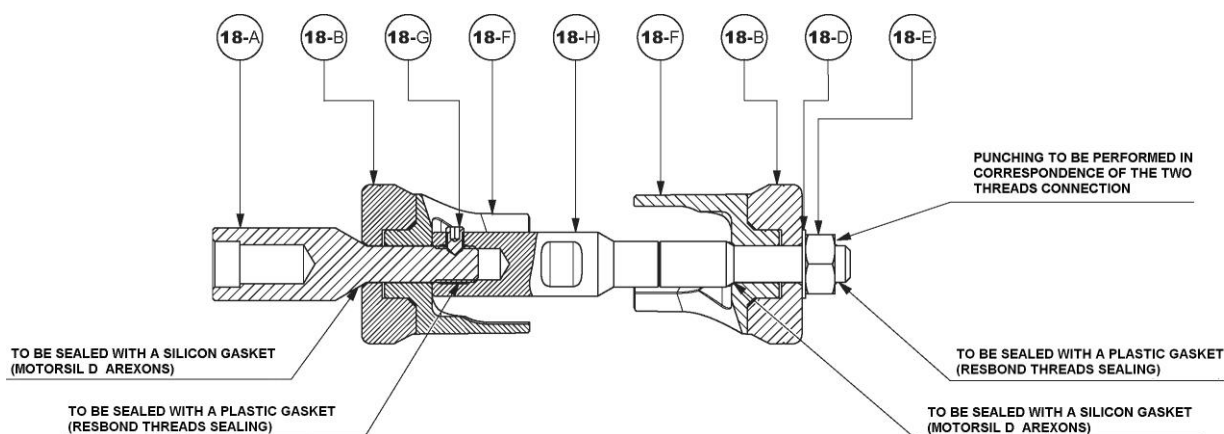

### 6.33 Parts and spare parts SBS/10 ND 15#50 2-WAY N.C./N.O.

Nr	DESCRIPTION	MATERIAL	
		version GJL-250	version GJS-500-7
1	Servo control spring	SPRING STEEL	
2	Spring-holding plate	Fe - P04	
3	Membrane	NBR rubber fabric	
4	Hexagon nut	Galvanized CL.8 STEEL	
5	Distance ring washer	S30400	
6	Diaphragm counterdisc	Galvanized ASTM A105	
7	O-Ring gasket	NBR	
8	Jig bushing	CuZn40Pb2 BRASS	
9	BA gasket	NBR	
10	Servo control shaft	S30400	
11	Adjustment nut	Galvanized Fe 430 B	
12	Hexagon nut	Galvanized CL.8 STEEL	
13	Packing gland screw	Galvanized CF9SMnPb36 STEEL	
14	Distance ring washer	S30400	
15	Packing gland	S31600	
16	Body gasket	NOVATEC O KEVLAR+GRAFITE	
17	Packing gland spring	PTFE + PTFE/GRAPHITE + FPM	
18	Shutter	T.P.	S30400+PEEK
		T.M.	S30400
19	Seat	S30400	
20	Upper head	Fe - P04	
21	Hexagonal-head screw	Galvanized CL.8.8 STEEL	
22	Flat washer	Galvanized STEEL	
23	Spring washer	Galvanized STEEL	
24	Hexagon nut	Galvanized CL.8 STEEL	
25	Lower head	Fe - P04 + copper STEEL	
26	Flat washer	Galvanized STEEL	
27	Spring washer	Galvanized STEEL	
28	Hexagon nut	Galvanized CL.8 STEEL	
29	Hexagonal-head screw	Galvanized CL.8.8 STEEL	
30	Clamp with indicator	CF8	
31	Spring washer	Galvanized STEEL	
32	Hexagon nut	Galvanized CL.8 STEEL	
33	Frame with intermediate body	GJL-250	
34	Stud-bolt	Galvanized CL.8.8 STEEL	
35	Hexagon nut	Galvanized CL.8 STEEL	
36	Spring washer	Galvanized STEEL	
37	Flat washer	Galvanized STEEL	
38	Valve body	GJL-250	GJS-500-7

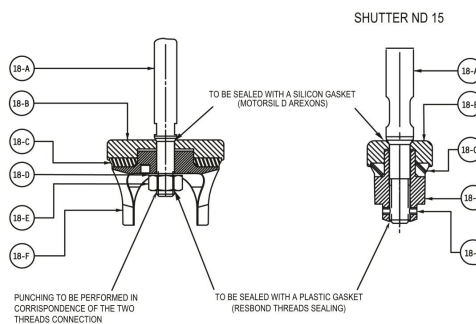
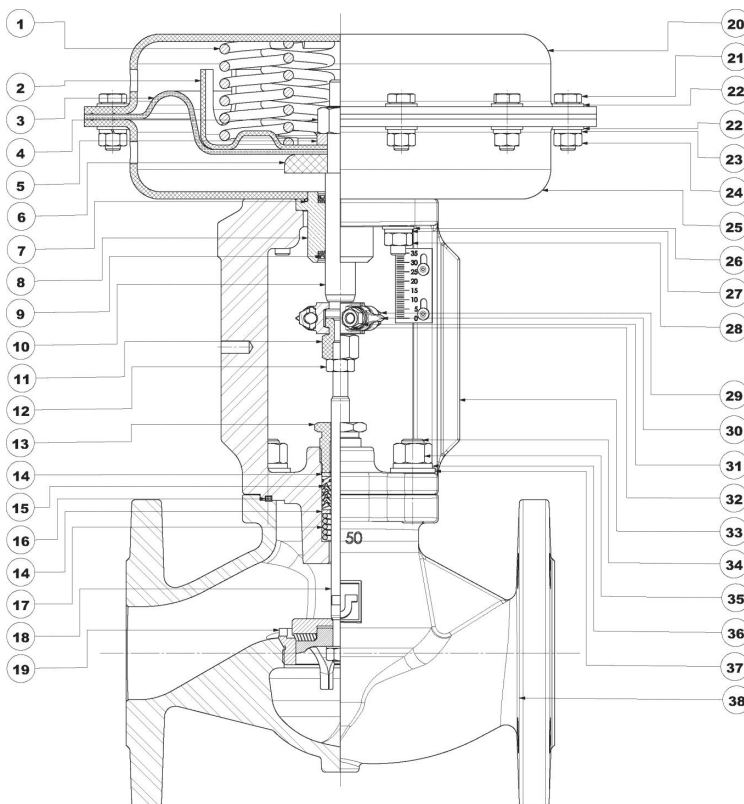

#### Body side spare parts

ND	SPARE PART CODE ( <sup>1</sup> ) (Part. No. 15/16/17/18-C/18-D/18-E/18-G)	
	SHUTTER T.PK.	SHUTTER T.M.
15	15349	12558
20	13529	
25	13449	
32	13539	11749
40	12545	
50	12546	

(<sup>1</sup>) Parts 18-C/18-D/18-E are for valves with plastic seals ND20#50 only. Parts 18-C/18-G are for valves with plastic seals ND15 only.

#### Air side spare parts

Ø servo control	SPARE PART CODE (Part. No. 3/7/9)
Ø 200	2655
Ø 275	5401
Ø 360	5402
Ø 430	5403

### 6.34 Parts and spare parts SBS/10 ND 65#80 2-WAY N.C./N.O.

Nr	DESCRIPTION	MATERIAL	
		version GJL-250	version GJS-500-7
1	Servo control spring	SPRING STEEL	
2	Spring-holding plate	Fe - P04	
3	Membrane	NBR rubber fabric	
4	Hexagon nut	Galvanized CL.8 STEEL	
5	Distance ring washer	S30400	
6	Diaphragm counterdisc	Galvanized ASTM A105	
7	O-Ring gasket	NBR	
8	Jig bushing	CuZn40Pb2 BRASS	
9	BA gasket	NBR	
10	Servo control shaft	S30400	
11	Adjustment nut	Galvanized Fe 430 B	
12	Hexagon nut	Galvanized CL.8 STEEL	
13	Packing gland screw	Galvanized CF9SMnPb36 STEEL	
14	Distance ring washer	S30400	
15	Packing gland	S31600	
17	Packing gland spring	PTFE + PTFE/GRAPHITE + FPM	
18	Shutter	T.P.	S30400+PEEK
		T.M.	S30400
19	Seat	S30400	
20	Upper head	Fe - P04	
21	Hexagonal-head screw	Galvanized CL.8.8 STEEL	
22	Flat washer	Galvanized STEEL	
23	Spring washer	Galvanized STEEL	
24	Hexagon nut	Galvanized CL.8 STEEL	
25	Lower head	Fe - P04 + copper STEEL	
26	Flat washer	Galvanized STEEL	
27	Spring washer	Galvanized STEEL	
28	Hexagon nut	Galvanized CL.8 STEEL	
29	Hexagonal-head screw	Galvanized CL.8.8 STEEL	
30	Clamp with indicator	CF8	
31	Spring washer	Galvanized STEEL	
32	Hexagon nut	Galvanized CL.8 STEEL	
34	Stud-bolt	Galvanized CL.8.8 STEEL	
35	Hexagon nut	Galvanized CL.8 STEEL	
36	Spring washer	Galvanized STEEL	
37	Flat washer	Galvanized STEEL	
38	Valve body	GJL-250	GJS-500-7
50	Body gasket	NOVATEC O KEVLAR+GRAFITE	
51	Intermediate body	Galvanized Fe 430 B	
57	Mounting valve	GJS-400-18-RT	

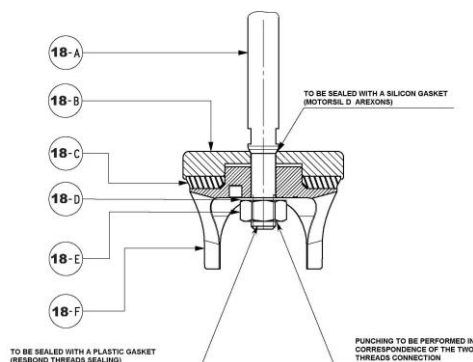
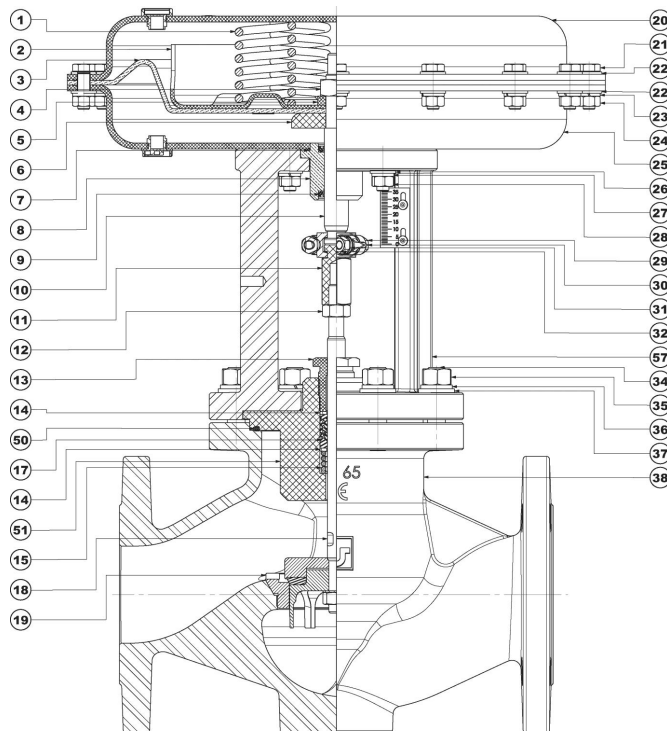

#### Body side spare parts

ND	SPARE PART CODE ( <sup>1</sup> ) (Part. No. 15/17/18-C/18-D/18-E-50)	
	SHUTTER T.P.K.	SHUTTER T.M.
65	14951	15264
80	14952	

(1) Parts 18-C/18-D/18-E are for valves with plastic seals only

#### Air side spare parts

Ø servo control	SPARE PART CODE (Part. No. 3/7/9)
Ø 200	2655
Ø 275	5401
Ø 360	5402
Ø 430	5403

### 6.35 Parts and spare parts SBS/10 ND 15#50 3-WAY N.C./N.O. mixer

Nr	DESCRIPTION	MATERIAL	
		version GJL-250	version GJS-500-7
1	Servo control spring	SPRING STEEL	
2	Spring-holding plate	Fe - P04	
3	Membrane	NBR rubber fabric	
4	Hexagon nut	Galvanized CL.8 STEEL	
5	Distance ring washer	S30400	
6	Diaphragm counterdisc	Galvanized ASTM A105	
7	O-Ring gasket	NBR	
8	Jig bushing	CuZn40Pb2 BRASS	
9	BA gasket	NBR	
10	Servo control shaft	S30400	
11	Adjustment nut	Galvanized Fe 430 B	
12	Hexagon nut	Galvanized CL.8 STEEL	
13	Packing gland screw	Galvanized CF9SMnPb36 STEEL	
14	Distance ring washer	S30400	
15	Packing gland	S31600	
16	Body gasket	NOVATEC O KEVLAR+GRAFITE	
17	Packing gland spring	PTFE + PTFE/GRAPHITE + FPM	
18	Shutter	T.P.	S30400+PEEK
		T.M.	S30400
19	Seat	S30400	
20	Upper head	Fe - P04	
21	Hexagonal-head screw	Galvanized CL.8.8 STEEL	
22	Flat washer	Galvanized STEEL	
23	Spring washer	Galvanized STEEL	
24	Hexagon nut	Galvanized CL.8 STEEL	
25	Lower head	Fe - P04 + copper STEEL	
26	Flat washer	Galvanized STEEL	
27	Spring washer	Galvanized STEEL	
28	Hexagon nut	Galvanized CL.8 STEEL	
29	Hexagonal-head screw	Galvanized CL.8.8 STEEL	
30	Clamp with indicator	CF8	
31	Spring washer	Galvanized STEEL	
32	Hexagon nut	Galvanized CL.8 STEEL	
33	Frame with intermediate body	GJL-250	
34	Stud-bolt	Galvanized CL.8.8 STEEL	
35	Hexagon nut	Galvanized CL.8 STEEL	
36	Spring washer	Galvanized STEEL	
37	Flat washer	Galvanized STEEL	
38	Valve body	GJL-250	GJS-500-7
39	Body gasket	NOVATEC O KEVLAR+GRAFITE	
40	Bottom base	GJL-250	GJS-500-7

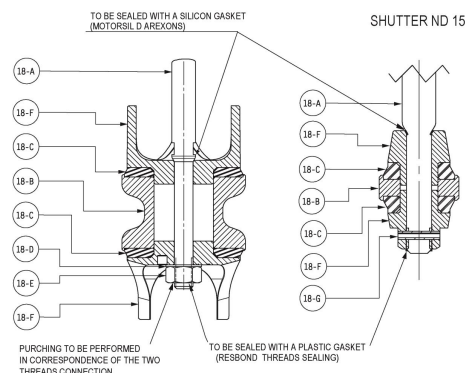
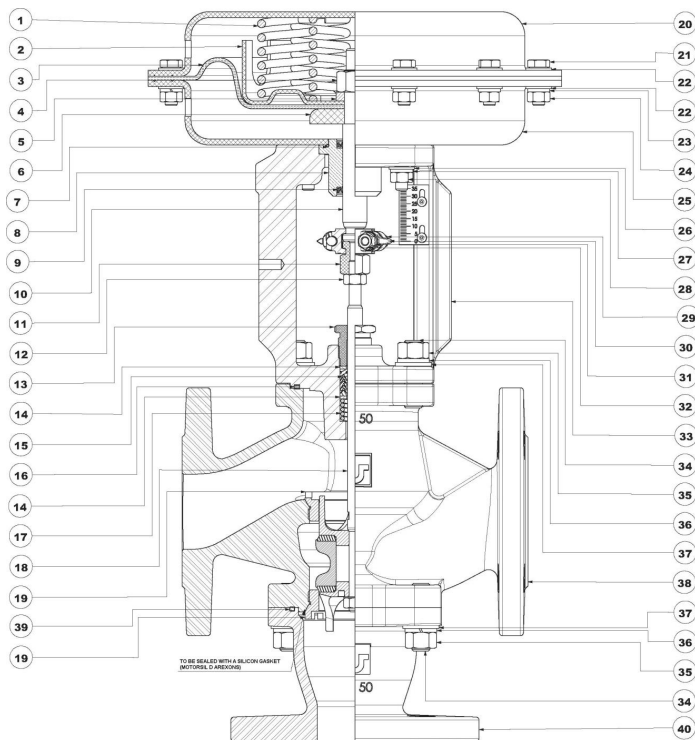

#### Body side spare parts

ND	SPARE PART CODE ( <sup>(1)</sup> Part. No. 15/16/17/18-C/18-D/18-E/18-G/39)	
	SHUTTER T.PK.	SHUTTER T.M.
15	14954	13533
20	13531	
25	13451	12555
32	13541	12556
40	12549	12557
50	13454	11961

(1) Parts 18-C/18-D/18-E are for valves with plastic seals ND20#50only. Parts 18-C/18-G are for valves with plastic seals ND15 only.

#### Air side spare parts

Ø servo control	SPARE PART CODE (Part. No. 3/7/9)
Ø 200	2655
Ø 275	5401
Ø 360	5402
Ø 430	5403

### 6.36 Parts and spare parts SBS/10 ND 65#80 3-WAY N.C./N.O. mixer

Nr	DESCRIPTION	MATERIAL	
		version GJL-250	version GJS-500-7
1	Servo control spring	SPRING STEEL	
2	Spring-holding plate	Fe - P04	
3	Membrane	NBR rubber fabric	
4	Hexagon nut	Galvanized CL.8 STEEL	
5	Distance ring washer	S30400	
6	Diaphragm counterdisc	Galvanized ASTM A105	
7	O-Ring gasket	NBR	
8	Jig bushing	CuZn40Pb2 BRASS	
9	BA gasket	NBR	
10	Servo control shaft	S30400	
11	Adjustment nut	Galvanized Fe 430 B	
12	Hexagon nut	Galvanized CL.8 STEEL	
13	Packing gland screw	Galvanized CF9SMnPb36 STEEL	
14	Distance ring washer	S30400	
15	Packing gland	S31600	
17	Packing gland spring	PTFE + PTFE/GRAPHITE + FPM	
18	Shutter	T.P.	S30400+PEEK
		T.M.	S30400
19	Seat	S30400	
20	Upper head	Fe - P04	
21	Hexagonal-head screw	Galvanized CL.8.8 STEEL	
22	Flat washer	Galvanized STEEL	
23	Spring washer	Galvanized STEEL	
24	Hexagon nut	Galvanized CL.8 STEEL	
25	Lower head	Fe - P04 + copper STEEL	
26	Flat washer	Galvanized STEEL	
27	Spring washer	Galvanized STEEL	
28	Hexagon nut	Galvanized CL.8 STEEL	
29	Hexagonal-head screw	Galvanized CL.8.8 STEEL	
30	Clamp with indicator	CF8	
31	Spring washer	Galvanized STEEL	
32	Hexagon nut	Galvanized CL.8 STEEL	
34	Stud-bolt	Galvanized CL.8.8 STEEL	
35	Hexagon nut	Galvanized CL.8 STEEL	
36	Spring washer	Galvanized STEEL	
37	Flat washer	Galvanized STEEL	
38	Valve body	GJL-250	GJS-500-7
39	Bottom gasket	NOVATEC O KEVLAR+GRAFITE	
40	Bottom base	GJL-250	GJS-500-7
50	Body gasket	NOVATEC O KEVLAR+GRAFITE	
51	Intermediate body	Galvanized Fe 430 B	
57	Mounting valve	GJS-400-18-RT	

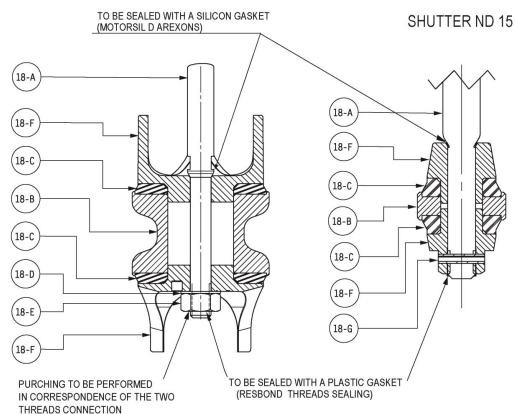
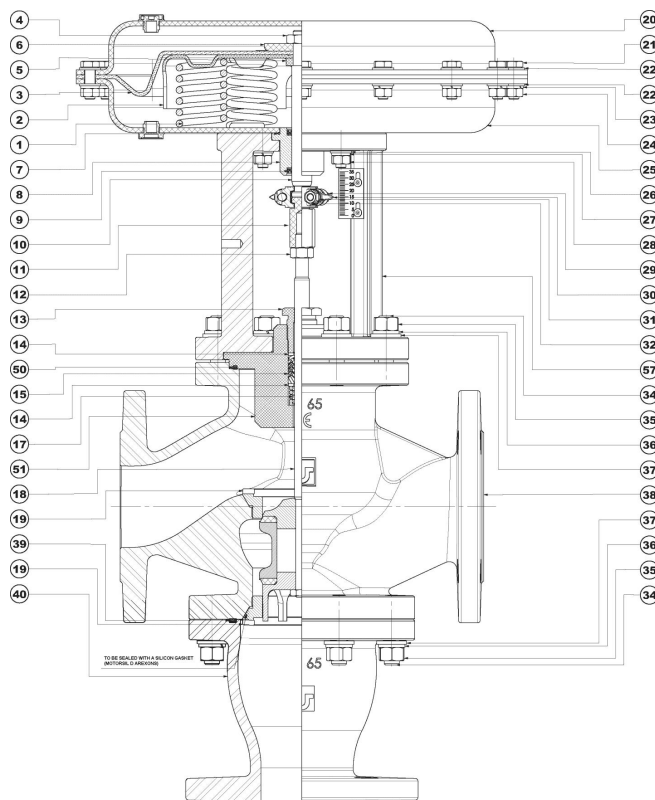

#### Body side spare parts

ND	SPARE PART CODE ( <sup>1</sup> ) (Part. No. 15/17/18-C/18-D/18-E/39/50)	
	SHUTTER T.PK.	SHUTTER T.M.
65	13692	13693
80	14955	14956

(<sup>1</sup>) Parts 18-C/18-D/18-E are for valves with plastic seals only

#### Air side spare parts

Ø servo control	SPARE PART CODE (Part. No. 3/7/9)
Ø 200	2655
Ø 275	5401
Ø 360	5402
Ø 430	5403



### 6.37 Parts and spare parts SBS/10 ND 15#50 3-WAY N.C./N.O. deviator

Nr	DESCRIPTION	MATERIAL	
		version GJL-250	version GJS-500-7
1	Servo control spring	SPRING STEEL	
2	Spring-holding plate	Fe - P04	
3	Membrane	NBR rubber fabric	
4	Hexagon nut	Galvanized CL.8 STEEL	
5	Distance ring washer	S30400	
6	Diaphragm counterdisc	Galvanized ASTM A105	
7	O-Ring gasket	NBR	
8	Jig bushing	CuZn40Pb2 BRASS	
9	BA gasket	NBR	
10	Servo control shaft	S30400	
11	Adjustment nut	Galvanized Fe 430 B	
12	Hexagon nut	Galvanized CL.8 STEEL	
13	Packing gland screw	Galvanized CF9SMnPb36 STEEL	
14	Distance ring washer	S30400	
15	Packing gland	S31600	
16	Body gasket	NOVATEC O KEVLAR+GRAFITE	
17	Packing gland spring	PTFE + PTFE/GRAPHITE + FPM	
18	Shutter	T.P.	S30400+PEEK
		T.M.	S30400
19	Seat	S30400	
20	Upper head	Fe - P04	
21	Hexagonal-head screw	Galvanized CL.8.8 STEEL	
22	Flat washer	Galvanized STEEL	
23	Spring washer	Galvanized STEEL	
24	Hexagon nut	Galvanized CL.8 STEEL	
25	Lower head	Fe - P04 + copper STEEL	
26	Flat washer	Galvanized STEEL	
27	Spring washer	Galvanized STEEL	
28	Hexagon nut	Galvanized CL.8 STEEL	
29	Hexagonal-head screw	Galvanized CL.8.8 STEEL	
30	Clamp with indicator	CF8	
31	Spring washer	Galvanized STEEL	
32	Hexagon nut	Galvanized CL.8 STEEL	
33	Frame with intermediate body	GJL-250	
34	Stud-bolt	Galvanized CL.8.8 STEEL	
35	Hexagon nut	Galvanized CL.8 STEEL	
36	Spring washer	Galvanized STEEL	
37	Flat washer	Galvanized STEEL	
38	Valve body	GJL-250	GJS-500-7
39	Body gasket	NOVATEC O KEVLAR+GRAFITE	
40	Bottom base	GJL-250	GJS-500-7

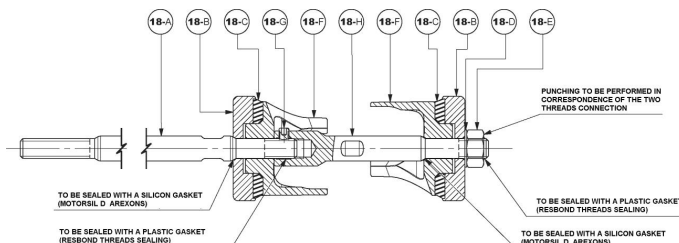
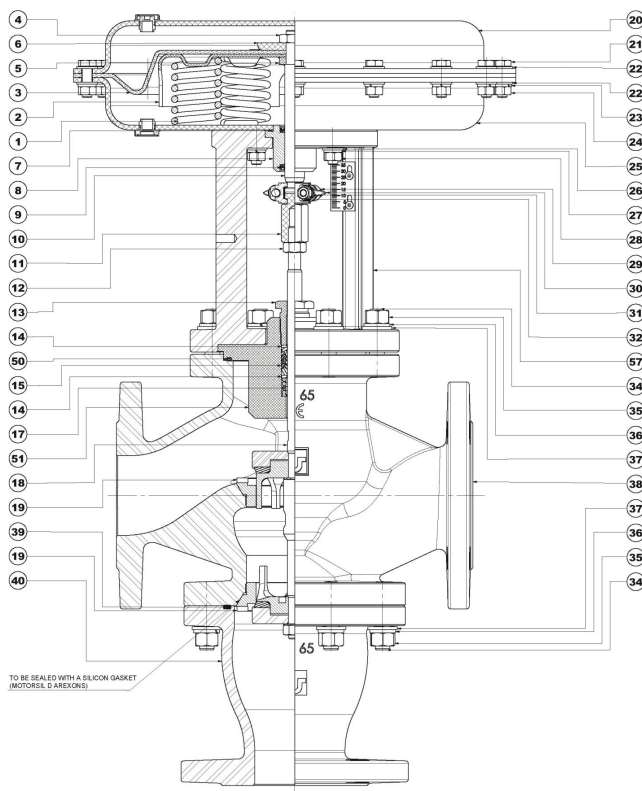

#### Body side spare parts

ND	SPARE PART CODE ( <sup>1</sup> ) (Part. No. 15/16/17/18-C/18-D/18-E/39)	
	SHUTTER T.PK.	SHUTTER T.M.
15	14962	13532
20	13530	
25	13450	12559
32	13540	12560
40	12553	12561
50	13453	13139

(<sup>1</sup>) Part 18-C is for valves with plastic seals only

#### Air side spare parts

Ø servo control	SPARE PART CODE (Part. No. 3/7/9)
Ø 200	2655
Ø 275	5401
Ø 360	5402
Ø 430	5403

## 6.1 Parts and spare parts SBS/10 ND 65#80 3-WAY N.C./N.O. deviator

Nr	DESCRIPTION	MATERIAL	
		version GJL-250	version GJS-500-7
1	Servo control spring	SPRING STEEL	
2	Spring-holding plate	Fe - P04	
3	Membrane	NBR rubber fabric	
4	Hexagon nut	Galvanized CL.8 STEEL	
5	Distance ring washer	S30400	
6	Diaphragm counterdisc	Galvanized ASTM A105	
7	O-Ring gasket	NBR	
8	Jig bushing	CuZn40Pb2 BRASS	
9	BA gasket	NBR	
10	Servo control shaft	S30400	
11	Adjustment nut	Galvanized Fe 430 B	
12	Hexagon nut	Galvanized CL.8 STEEL	
13	Packing gland screw	Galvanized CF9SMnPb36 STEEL	
14	Distance ring washer	S30400	
15	Packing gland	S31600	
17	Packing gland spring	PTFE + PTFE/GRAPHITE + FPM	
18	Shutter	T.P.	S30400+PEEK
		T.M.	S30400
19	Seat	S30400	
20	Upper head	Fe - P04	
21	Hexagonal-head screw	Galvanized CL.8.8 STEEL	
22	Flat washer	Galvanized STEEL	
23	Spring washer	Galvanized STEEL	
24	Hexagon nut	Galvanized CL.8 STEEL	
25	Lower head	Fe - P04 + copper STEEL	
26	Flat washer	Galvanized STEEL	
27	Spring washer	Galvanized STEEL	
28	Hexagon nut	Galvanized CL.8 STEEL	
29	Hexagonal-head screw	Galvanized CL.8.8 STEEL	
30	Clamp with indicator	CF8	
31	Spring washer	Galvanized STEEL	
32	Hexagon nut	Galvanized CL.8 STEEL	
34	Stud-bolt	Galvanized CL.8.8 STEEL	
35	Hexagon nut	Galvanized CL.8 STEEL	
36	Spring washer	Galvanized STEEL	
37	Flat washer	Galvanized STEEL	
38	Valve body	GJL-250	GJS-500-7
39	Bottom gasket	NOVATEC O KEVLAR+GRAFITE	
40	bottom	GJL-250	GJS-500-7
50	Body gasket	NOVATEC O KEVLAR+GRAFITE	
51	Intermediate body	Galvanized Fe 430 B	
57	Mounting valve	GJS-400-18-RT	

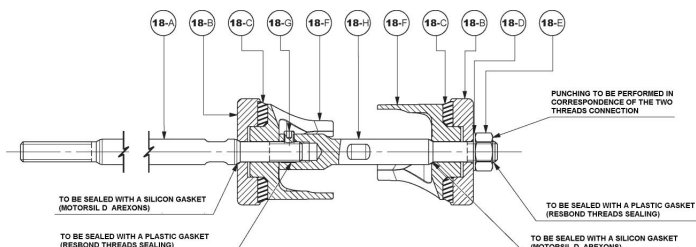
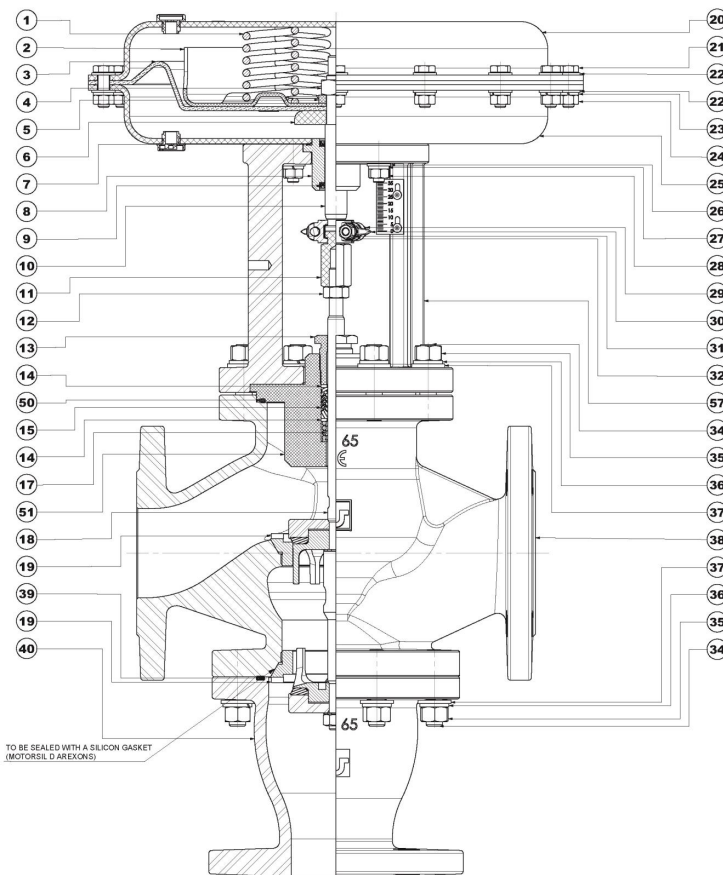

### Body side spare parts

ND	SPARE PART CODE ( <sup>1</sup> ) (Part. No. 15/17/18-C/18-D/18-E/39/50)	
	65	13694
80	15450	14964

### Air side spare parts

Ø servo control	SPARE PART CODE (Part. No. 3/7/9)
Ø 200	2655
Ø 275	5401
Ø 360	5402
Ø 430	5403



## 6.2 Parts and spare parts SBS/10 ND 15#50 2-WAY N.C./N.O. with bellows

Nr	DESCRIPTION	MATERIAL
		Version GJS-500-7
1	Servo control spring	SPRING STEEL
2	Spring-holding plate	Fe - P04
3	Membrane	NBR rubber fabric
4	Hexagon nut	Galvanized CL.8 STEEL
5	Distance ring washer	S30400
6	Diaphragm counterdisc	Galvanized ASTM A105
7	O-Ring gasket	NBR
8	Jig bushing	CuZn40Pb2 BRASS
9	BA gasket	NBR
10	Servo control shaft	S30400
11	Adjustment nut	Galvanized Fe 430 B
12	Hexagon nut	Galvanized CL.8 STEEL
13	Packing gland screw	Galvanized CF9SMnPb36 STEEL
14	Distance ring washer	S30400
15	Packing gland	S31600
16	Body gasket	NOVATEC O KEVLAR+GRAFITE
17	Packing gland spring	PTFE + PTFE/GRAPHITE + FPM
18	Shutter	S30400
19	Seat	S30400
20	Upper head	Fe - P04
21	Hexagonal-head screw	Galvanized CL.8.8 STEEL
22	Flat washer	Galvanized STEEL
23	Spring washer	Galvanized STEEL
24	Hexagon nut	Galvanized CL.8 STEEL
25	Lower head	Fe - P04 + copper STEEL
26	Flat washer	Galvanized STEEL
27	Spring washer	Galvanized STEEL
28	Hexagon nut	Galvanized CL.8 STEEL
29	Hexagonal-head screw	Galvanized CL.8.8 STEEL
30	Clamp with indicator	CF8
31	Spring washer	Galvanized STEEL
32	Hexagon nut	Galvanized CL.8 STEEL
33	Frame with intermediate body	GJL-250
34	Stud-bolt	Galvanized CL.8.8 STEEL
35	Hexagon nut	Galvanized CL.8 STEEL
36	Spring washer	Galvanized STEEL
37	Flat washer	Galvanized STEEL
38	Valve body	GJS-500-7
41	Upper stem	S30400
42	Headless screw	S30400
43	Intermediate body with bellows	S30400 - S31600
44	Gasket	NOVATEC O KEVLAR+GRAFITE
45	Hexagonal-head screw	Galvanized CL.8.8 STEEL
46	Flat washer	Galvanized STEEL
47	Spring washer	Galvanized STEEL
48	Hexagon nut	Galvanized CL.8 STEEL
49	Frame extension	Fe 360

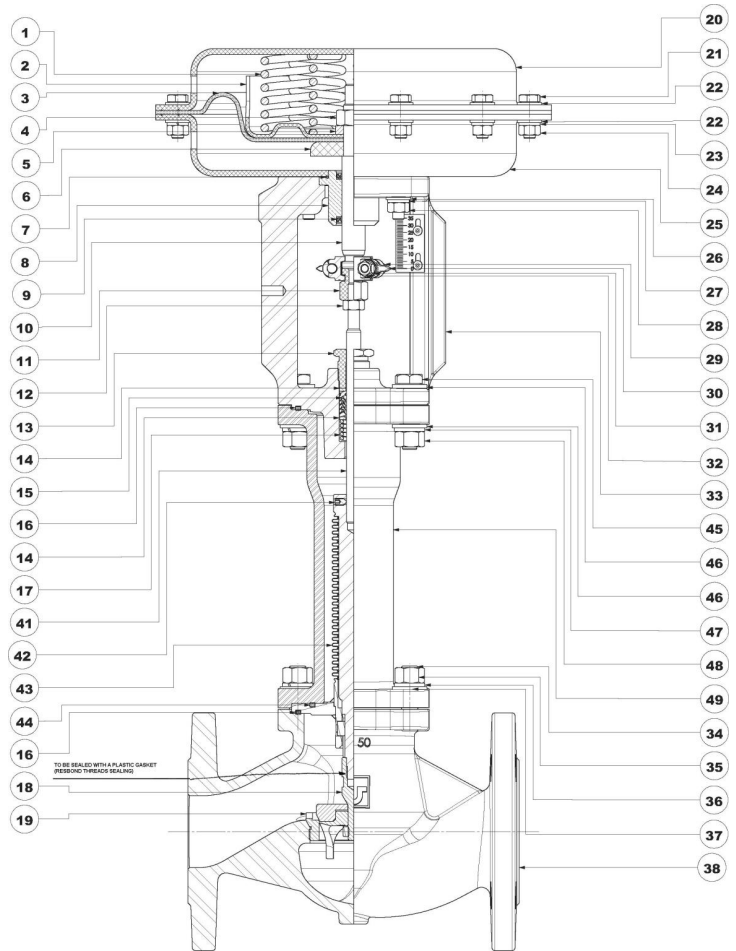

### Body side spare parts

ND	SPARE PART CODE (Part. No. 15/16/17/44)
	SHUTTER T.M.
15	13804
20	13804
25	12570
32	12571
40	12571
50	12571

### Air side spare parts

Ø servo control	SPARE PART CODE (Part. No. 3/7/9)
Ø 200	2655
Ø 275	5401
Ø 360	5402
Ø 430	5403

## 6.1 Parts and spare parts SBS/10 ND 65#80 2-WAY N.C./N.O. with bellows

Nr	DESCRIPTION	MATERIAL
		Version GJS-500-7
1	Servo control spring	SPRING STEEL
2	Spring-holding plate	Fe - P04
3	Membrane	NBR rubber fabric
4	Hexagon nut	Galvanized CL.8 STEEL
5	Distance ring washer	S30400
6	Diaphragm counterdisc	Galvanized ASTM A105
7	O-Ring gasket	NBR
8	Jig bushing	CuZn40Pb2 BRASS
9	BA gasket	NBR
10	Servo control shaft	S30400
11	Adjustment nut	Galvanized Fe 430 B
12	Hexagon nut	Galvanized CL.8 STEEL
13	Packing gland screw	Galvanized CF9SMnPb36 STEEL
14	Distance ring washer	S30400
15	Packing gland	S31600
17	Packing gland spring	PTFE + PTFE/GRAPHITE + FPM
18	Shutter	S30400
19	Seat	S30400
20	Upper head	Fe - P04
21	Hexagonal-head screw	Galvanized CL.8.8 STEEL
22	Flat washer	Galvanized STEEL
23	Spring washer	Galvanized STEEL
24	Hexagon nut	Galvanized CL.8 STEEL
25	Lower head	Fe - P04 + copper STEEL
26	Flat washer	Galvanized STEEL
27	Spring washer	Galvanized STEEL
28	Hexagon nut	Galvanized CL.8 STEEL
29	Hexagonal-head screw	Galvanized CL.8.8 STEEL
30	Clamp with indicator	CF8
31	Spring washer	Galvanized STEEL
32	Hexagon nut	Galvanized CL.8 STEEL
34	Stud-bolt	Galvanized CL.8.8 STEEL
35	Hexagon nut	Galvanized CL.8 STEEL
36	Spring washer	Galvanized STEEL
37	Flat washer	Galvanized STEEL
38	Valve body	GJS-500-7
41	Upper stem	S30400
42	Headless screw	S30400
43	Intermediate body with bellows	S30400 - S31600
44	Gasket	NOVATEC O KEVLAR+GRAFITE
45	Hexagonal-head screw	Galvanized CL.8.8 STEEL
46	Flat washer	Galvanized STEEL
47	Spring washer	Galvanized STEEL
48	Hexagon nut	Galvanized CL.8 STEEL
49	Frame extension	Fe 360

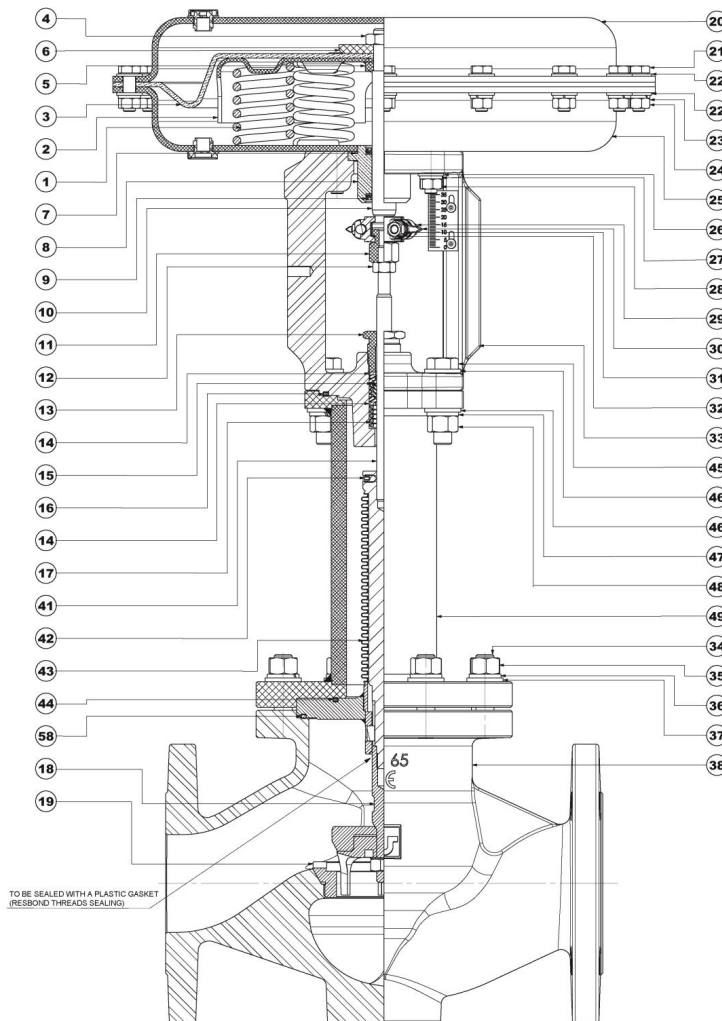

### Body side spare parts

ND	SPARE PART CODE (Part. No. 15/16/17/44/58)
	SHUTTER T.M.
65	13696
80	

### Air side spare parts

Ø servo control	SPARE PART CODE (Part. No. 3/7/9)
Ø 200	2655
Ø 275	5401
Ø 360	5402
Ø 430	5403

## 6.2 Parts and spare parts SBS/10 3-way N.C./N.O. mixer with bellows

Nr	DESCRIPTION	MATERIAL
		Version GJS-500-7
1	Servo control spring	SPRING STEEL
2	Spring-holding plate	Fe - P04
3	Membrane	NBR rubber fabric
4	Hexagon nut	Galvanized CL.8 STEEL
5	Distance ring washer	S30400
6	Diaphragm counterdisc	Galvanized ASTM A105
7	O-Ring gasket	NBR
8	Jig bushing	CuZn40Pb2 BRASS
9	BA gasket	NBR
10	Servo control shaft	S30400
11	Adjustment nut	Galvanized Fe 430 B
12	Hexagon nut	Galvanized CL.8 STEEL
13	Packing gland screw	Galvanized CF9SMnPb36 STEEL
14	Distance ring washer	S30400
15	Packing gland	S31600
16	Body gasket	NOVATEC O KEVLAR+GRAFITE
17	Packing gland spring	PTFE + PTFE/GRAPHITE + FPM
18	Shutter	S30400
19	Seat	S30400
20	Upper head	Fe - P04
21	Hexagonal-head screw	Galvanized CL.8.8 STEEL
22	Flat washer	Galvanized STEEL
23	Spring washer	Galvanized STEEL
24	Hexagon nut	Galvanized CL.8 STEEL
25	Lower head	Fe - P04 + copper STEEL
26	Flat washer	Galvanized STEEL
27	Spring washer	Galvanized STEEL
28	Hexagon nut	Galvanized CL.8 STEEL
29	Hexagonal-head screw	Galvanized CL.8.8 STEEL
30	Clamp with indicator	CF8
31	Spring washer	Galvanized STEEL
32	Hexagon nut	Galvanized CL.8 STEEL
33	Frame with intermediate body	GJL-250
34	Stud-bolt	Galvanized CL.8.8 STEEL
35	Hexagon nut	Galvanized CL.8 STEEL
36	Spring washer	Galvanized STEEL
37	Flat washer	Galvanized STEEL
38	Valve body	GJS-500-7
39	Bottom base gasket	NOVATEC O KEVLAR+GRAFITE
40	Bottom base	GJS-500-7
41	Upper stem	S30400
42	Headless screw	S30400
43	Intermediate body with bellows	S30400 - S31600
44	Gasket	NOVATEC O KEVLAR+GRAFITE
45	Hexagonal-head screw	Galvanized CL.8.8 STEEL
46	Flat washer	Galvanized STEEL
47	Spring washer	Galvanized STEEL
48	Hexagon nut	Galvanized CL.8 STEEL
49	Frame extension	Fe 360

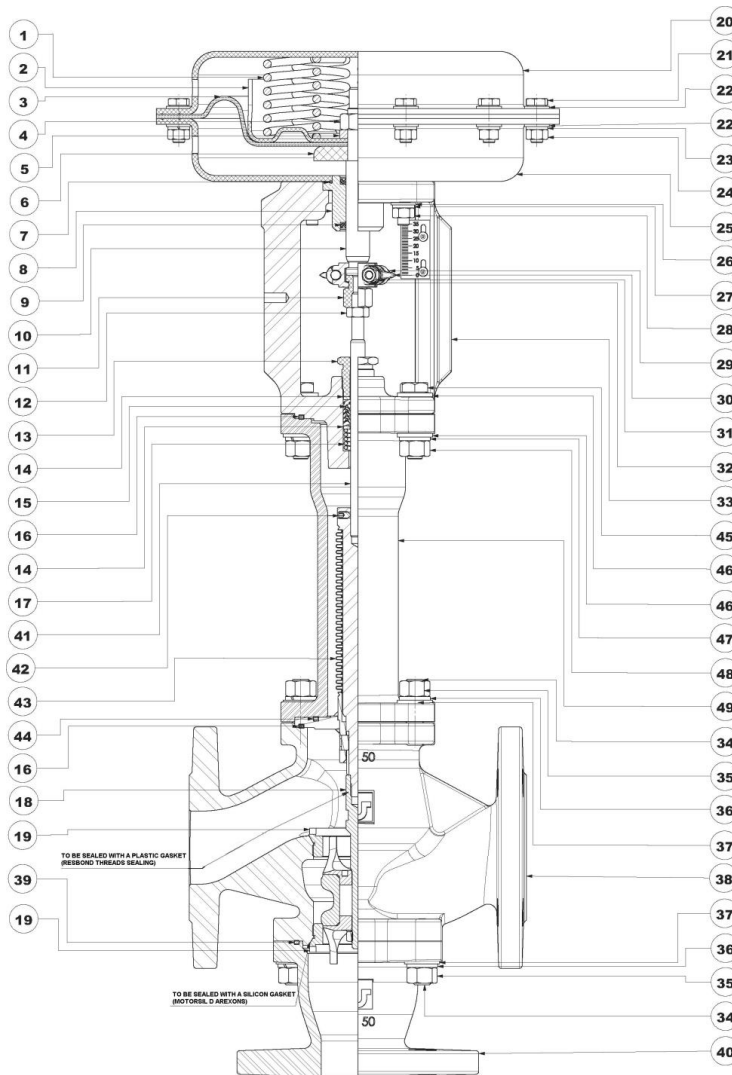

### Body side spare parts

ND	SPARE PART CODE (Part. No. 15/16/17/39/44)
	SHUTTER T.M.
15	13689
20	13689
25	12572
32	12573
40	12574
50	12575
65	13697
80	14957

### Air side spare parts

Ø servo control	SPARE PART CODE (Part. No. 37/9)
Ø 200	2655
Ø 275	5401
Ø 360	5402
Ø 430	5403

### 6.3 Parts and spare parts SBS/10 3-way N.C./N.O. deviator with bellows

Nr	DESCRIPTION	MATERIAL
		Version GJS-500-7
1	Servo control spring	SPRING STEEL
2	Spring-holding plate	Fe - P04
3	Membrane	NBR rubber fabric
4	Hexagon nut	Galvanized CL.8 STEEL
5	Distance ring washer	S30400
6	Diaphragm counterdisc	Galvanized ASTM A105
7	O-Ring gasket	NBR
8	Jig bushing	CuZn40Pb2 BRASS
9	BA gasket	NBR
10	Servo control shaft	S30400
11	Adjustment nut	Galvanized Fe 430 B
12	Hexagon nut	Galvanized CL.8 STEEL
13	Packing gland screw	Galvanized CF9SMnPb36 STEEL
14	Distance ring washer	S30400
15	Packing gland	S31600
16	Body gasket	NOVATEC O KEVLAR+GRAFITE
17	Packing gland spring	PTFE + PTFE/GRAPHITE + FPM
18	Shutter	S30400
19	Seat	S30400
20	Upper head	Fe - P04
21	Hexagonal-head screw	Galvanized CL.8.8 STEEL
22	Flat washer	Galvanized STEEL
23	Spring washer	Galvanized STEEL
24	Hexagon nut	Galvanized CL.8 STEEL
25	Lower head	Fe - P04 + copper STEEL
26	Flat washer	Galvanized STEEL
27	Spring washer	Galvanized STEEL
28	Hexagon nut	Galvanized CL.8 STEEL
29	Hexagonal-head screw	Galvanized CL.8.8 STEEL
30	Clamp with indicator	CF8
31	Spring washer	Galvanized white STEEL
32	Hexagon nut	Galvanized white CL. 8 STEEL
33	Frame with intermediate body	GJL-250
34	Stud-bolt	Galvanized CL.8.8 STEEL
35	Hexagon nut	Galvanized CL.8 STEEL
36	Spring washer	Galvanized STEEL
37	Flat washer	Galvanized STEEL
38	Valve body	GJS-500-7
39	Bottom base gasket	NOVATEC O KEVLAR+GRAFITE
40	Bottom base	GJS-500-7
41	Upper stem	S30400
42	Headless screw	S30400
43	Intermediate body with bellows	S30400 - S31600
44	Gasket	NOVATEC O KEVLAR+GRAFITE
45	Hexagonal-head screw	Galvanized CL.8.8 STEEL
46	Flat washer	Galvanized STEEL
47	Spring washer	Galvanized STEEL
48	Hexagon nut	Galvanized CL.8 STEEL
49	Frame extension	Fe 360

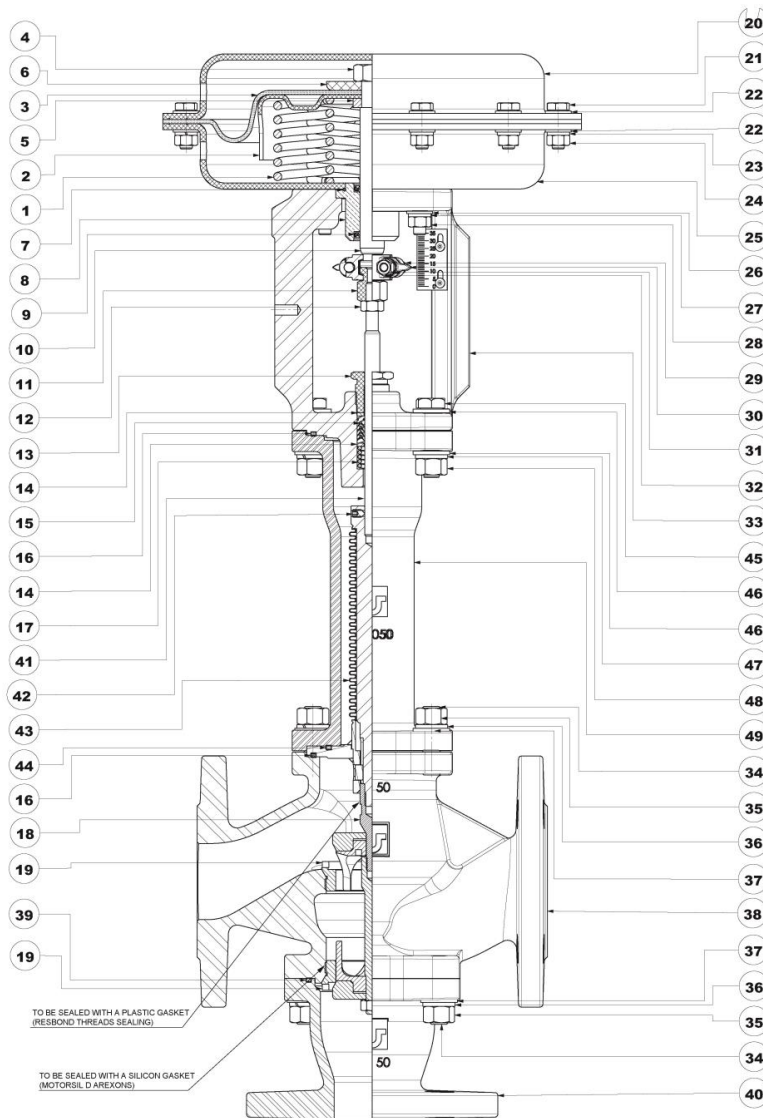

#### Body side spare parts

ND	SPARE PART CODE (Part. No. 15/16/17/18-D/18-E/39/44)	
	SHUTTER T.M.	
15	13690	
20	13690	
25	12576	
32	12577	
40	12578	
50	12579	
65	13698	
80	14965	

#### Air side spare parts

Ø servo control	SPARE PART CODE (Part. No. 37/9)
Ø 200	2655
Ø 275	5401
Ø 360	5402
Ø 430	5403

## 7 Table 5: Servo control springs

Øe SERV	STROKE (mm)	SIGNAL											
		3 ÷ 15		6 ÷ 18		6 ÷ 30		9 ÷ 32		3 ÷ 9		9 ÷ 15	
		N°	CODICE	N°	CODICE	N°	CODICE	N°	CODICE	N°	CODICE	N°	CODICE
200	15	3	MTD086100	3	MTD086101	6	MTD086100	6	MTD086102	3	MOLL092037	3	MOLL940412
	20	3	MOLL110523	3	MOLL100804	6	MOLL110523	6		3		3	
275	15	3	MTD086106	6	MTD086107	6	MTD086106	6	MTD086108	3	MTD086107	3	MOLL092038
	20	3	MOLL100528	6	MOLL100529	6	MOLL100528	6	MOLL100530	3		3	
360	15	6	MTD086106	12	MTD086107	12	MTD086106	12	MTD086108	6	MTD086107	6	MOLL092038
	20	6	MOLL100528	12	MOLL100529	12	MOLL100528	12	MOLL100530	6		6	
430	15	4	MTD086103	8	MTD086104	8	MTD086103	8	MTD086105	4	MTD086104		
	20	4	MOLL100532	8	MOLL100533	8	MOLL100532	8	MOLL100534	4			
	30	4	MOLL950278	8	MOLL950279	8	MOLL950278	8	MOLL950280	4			

## 8 Table 6: Tightening Torques

Part couplings	Tightening torque for SBS/10 valve threaded couplings [N·m]											
	Servo Control Couplings Øe Serv.				Body couplings ND							
	200	275	360	430	15	20	25	32	40	50	65	80
Part 21 – Part. 24	12		17									
Part 28 – Part. 25			17									
Part 34 – Part. 35												
Part 45 – Part. 48												
Part 19 – Part. 38					170	170	212	370	503	625	-	-
Part 18-A – Part. 18-E	TP				9				18		32	-
	TM				12				19		32	-
Part 18-G – Part. 18-E	TP				9				18		32	-
	TM				12				19		32	-
Part 38 – Part. 56											17	

## 9 Valve life

SBS-series valve has been designed and manufactured to ensure proper operation under conditions and limits provided for by technical characteristics.

All fastened metal parts not involved in sealing have an expected life of 10 years. Sealing and moving parts must be subject to complete overhaul within a time interval shorter than 500000 manoeuvres and three years.

This overhaul operation can be carried out by specialized personnel only.

Scheduled maintenance operations shall be carried out independently of the ones due to possible failures, which always require an immediate intervention.

## 10 Disposal

After use, for the valve disposal, it is necessary to disassemble the valve and separate the different materials the valve is composed of, according to the tables annexed to the valve working drawings, then dispose of the different materials in compliance with the laws in force.

Assembly and disassembly operations shall be carried out by qualified personnel only, equipped with all the work and safety tools. **ATTENTION! Compressed springs are included inside the servo control.** Thus, during valve disassembly, components are disposed of by using all safety equipment necessary to prevent sudden separation of upper head from lower head when all servo control head fastening screws have been removed.

## 11 Warranty

Every valve is checked before leaving the factory. On request of customer a certificate of control can be issued. The customer himself can inspect and check the material at our factory before shipment. Such inspection is considered definitive.

All expenses relative to special checks or requirements by the customer are at the customers expense.

Our responsibility is limited to the replacement or repair of parts which develop material or manufacturing defects within 12 months from shipment and which have been used in normal working conditions. This use exclude every and any other obligation. All transport and additional costs are at the customer expense.

Our responsibility (for damage to person or/and properties during installation and/or maintenance) lapses when the valve is removed from its original packaging.

ITALVALVOLE<sup>®</sup> reserved the right to stop, change or modify the characteristics of any of its products without being obliged to replace or mount the modified parts on products already supplied.

### **WARNINGS:**

- The safety conditions shall not be guaranteed and malfunctions shall not be subjected to valves in case:
  - disassembly, re-assembly, maintenance operations are not carried out in compliance with the use and maintenance manual.
  - original spare parts are not used.
- It is forbidden to remove pages from this document or to make any correction.
- In case of doubt, make reference to Italian version of the manual.
- ITALVALVOLE<sup>®</sup> S.A.S. reserves the right to change its products and the relevant documentation without prior notice.
- The use of the handbook does not exempt from the observance of the laws in force.
- We inform you that some components may come from countries other than Italy.