

**T-Series Thermowells - Model TF Flanged Wells, Model TT Threaded Wells, Model TW Weld-In Wells, and Model TS Sanitary Wells**

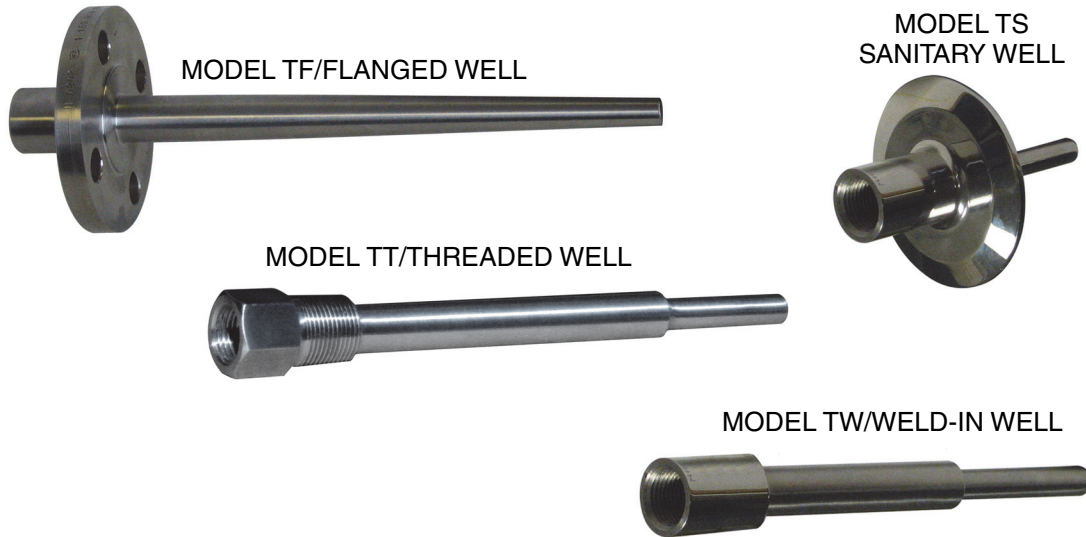

*The T-Series thermowells separate the temperature-measuring sensitive portion of a thermocouple or resistance temperature detector from potentially corrosive or damaging process media. These wells are offered in many configurations and permit ready removal of the sensor without process shutdown.*

**PROVEN DEPENDABILITY**

Foxboro thermowells have been a widely accepted standard of the process control industry for over sixty years. Many thousands of successful, trouble-free installations have demonstrated the exceptional dependability of these wells.

**HIGH QUALITY CONSTRUCTION**

These thermowells are made to accept standard or custom temperature sensors. Wells are machined from industry standard 316 ss, and a polished finish assures maximum corrosion resistance. All wells are manufactured in accordance with applicable ASME (PTC - Performance Test Code), ASTM, and ANSI standards.

### **SPECIAL SANITARY CONSTRUCTION**

The Model TS Sanitary Well is further polished to a finish exceeding Ra 32 microinches, and the 3A number 4 finish. This provides a surface free of bacteria-harboring surface irregularities.

### **NUMEROUS CONFIGURATIONS AVAILABLE**

A selection of straight, tapered, or stepped shank wells is offered. U-lengths range from 2 to 36 in (51 to 914 mm), and lagging lengths range from 2 to 4 in (51 to 102 mm). The process connection can either be an ANSI Class 150, 300, or 600 flange, a 1/2,

3/4, or 1 NPT external thread, a 1.05-, 1.315-, or 1.5-inch O.D. Well connection for socket-welding, or a 3/4-, 1-, 1 1/2-, 2-, or 3-inch Tri-Clamp. A 1/2 in internal NPT thread is provided on all well heads for sensor entry.

### **TOTAL TEMPERATURE SOLUTIONS**

We offer a complete line of temperature transmitters, sensors, thermowells, connection heads, controllers, and recorders to meet all of your requirements. Let us make this process easy for you.



THERMOWELL CONFIGURATIONS

(See Dimensions - Nominal Section for details)

Model (a)		Shank Type (b)	No Lagging (a)	With Lagging Extension T (a)
Code	Type		(Code 0)	(Codes 20 to 40)
TF	Flanged	Straight (Code 2)		
		Stepped (Code 3)		
		Tapered (Code 4)		
TT	Threaded	Straight (Code 2)		
		Stepped (code 3)		
		Tapered (code 4)		

(a) Refer to MODEL CODE section.

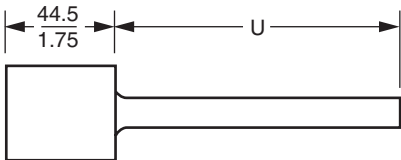
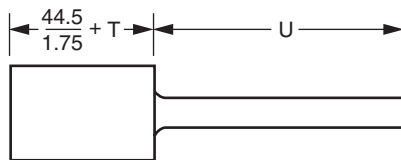
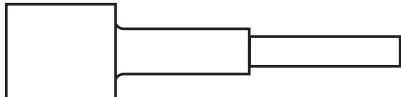
(b) Refer to RECOMMENDED WELL APPLICATIONS section.

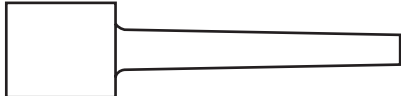
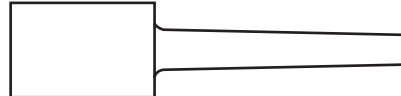
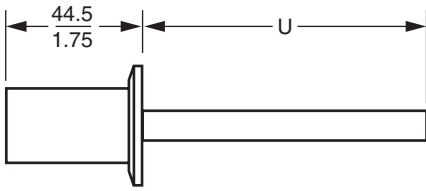
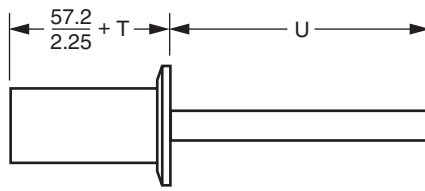
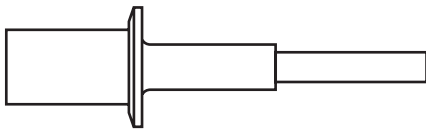
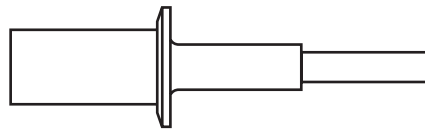
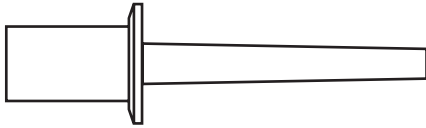
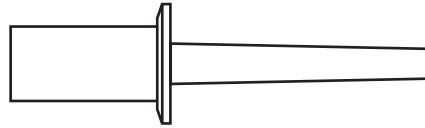
Model (a)		Shank Type (b)	No Lagging (a) (Code 0)	With Lagging Extension T (a) (Codes 20 to 40)
Code	Type			
TW	Weld-In	Straight (Code 2)		
		Stepped (Code 3)		
		Tapered (Code 4)		
TS	Sanitary	Straight (Code 2)		
		Stepped (Code 3)		
		Tapered (Code 4)		

(a) Refer to MODEL CODE section.

(b) Refer to RECOMMENDED WELL APPLICATIONS section.

**STANDARD SPECIFICATIONS**

**Materials**

Industry standard AISI Type 316 ss. Contact Global Customer Support for other offerings.

**Process Connection Type**

**MODEL TF FLANGED WELLS**

ANSI Class 150, 300, or 600

**MODEL TT THREADED WELLS**

1/2, 3/4, or 1 NPT

**MODEL TW WELD-IN WELLS**

- 1.05-inch O.D. well connection;  
nominal 3/4-inch pipe, socket weld
- 1.315-inch O.D. well connection;  
nominal 1-inch pipe, socket weld
- 1.5-inch Diameter, Weld-in

**MODEL TS SANITARY WELLS**

- 3/4-inch Tri-Clamp
- 1-inch Tri-Clamp
- 1 1/2-inch Tri-Clamp
- 2-inch Tri-Clamp
- 3-inch Tri-Clamp

**Finish**

Models TF, TT, and TW wells are polished to 63 rms. Contact Global Customer Support if other finishes are required. Model TS wells are polished to exceed an Ra 32 microinch, and a 3A number 4 finish.

**Insertion Length U**

This is the shank length from below the inner surface/end of the process connection to the tip of the well. See Model Code section for insertion lengths offered. Also see Dimensions section.

**Lagging Length T**

Standard construction is with no lagging (T=0). For users who require lagging, T-lengths from 2 to 4 in (50.8 to 101.6 mm) in 1/2 in (12.7 mm) increments can be provided. Refer to the Dimensions section.

**Shank Type Well Selections (Also see Recommended Well Applications section)**

**STRAIGHT SHANK WELLS**

Recommended when the user's prime need is a quick response time. See Model Code.

**TAPERED SHANK WELLS**

Recommended when the user's prime need is strength and rigidity.

**STEPPED SHANK WELLS**

Recommended as the best compromise where both speed of response and strength/rigidity are equally important.

**Special Purpose Applications**

A Model TS Well meets the special needs of the dairy, food, and pharmaceutical industries requiring a Tri-Clamp type sanitary end connection interface with the process.

**Dimensions**

Refer to Dimensions section and table below.

Thermowell Model	Dimensional Print
Model TF	DP 002-110
Model TT	DP 002-112
Mode TW	DP 002-113
Model TS	DP 002-111

**Pressure-Temperature Ratings**

**MODEL TF FLANGED WELLS**

Refer to Figure 1 for the pressure-temperature limits of Model TF wells. These wells were successfully hydrostatically pressure tested at 1.5 times the maximum working pressure of the specified flange at 24°C (75°F). Do not exceed the pressure-temperature limits shown in Figure 1.

*Figure 1. Pressure-Temperature Limits of Model TF*

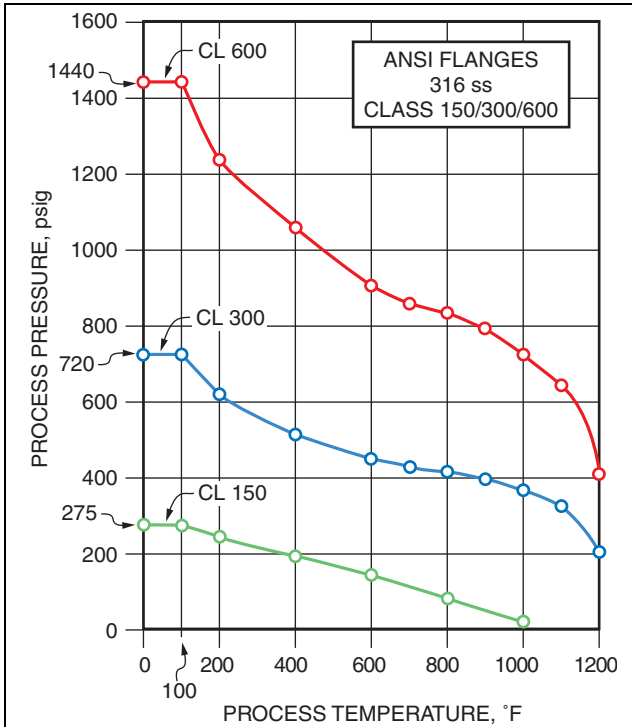

**MODEL TT THREADED AND MODEL TW WELD-IN WELLS**

Models TT and TW Wells were hydrostatically pressure tested at 17.25 MPa (2500 psi) with no leakage. The process pressure should not exceed this 17.25 MPa (2500 psi) rating, to process temperatures up to 650°C (1200°F).

**MODEL TS SANITARY WELLS**

Model TS Wells were hydrostatically pressure tested at 17.25 MPa (2500 psi) with no leakage. The pressure limit of the well is 17.25 MPa at 650°C (2500 psi at 1200°F), or the rating of the Tri-Clamp used, whichever is less.

## RECOMMENDED WELL APPLICATIONS

Also see Wake Frequency Note below.

### Straight Shank Well

The straight shank is recommended for those user's whose prime need is a response time quicker than either a tapered or stepped shank well. The quicker response is because the straight shank has a lesser surface and tip area than the other two. See NOTE below.

#### NOTE

In general, user's should not select straight shank wells whenever the "U" length is greater than 6 in (152 mm). If a "U" length greater than 6 in (152 mm) is required, a stepped shank well will be provided. Refer to Model Code and Dimensions-Nominal sections, and contact Global Customer Support if further information is desired.

### Tapered Shank Well

The tapered shank is recommended when the user's primary need is strength and rigidity. This well provides greater stiffness for roughly the same sensitivity as either the straight or stepped shank wells. Typical applications include processes having fast and vibrating atmospheres like high velocity flow and pressure measurements.

### Stepped Shank Well

The stepped shank well provides the best compromise when both speed of response, and strength and rigidity are about equally desired. Typical applications include liquid level, viscous, and abrasive processes.

## WAKE FREQUENCY NOTE

Wake Frequency calculations are often required to determine if the thermowell is strong enough to withstand the process conditions in the pipeline or vessel. "Von Karman Trail" refers to the turbulent wake which is formed as fluid flows past a thermowell. A vibration frequency is determined depending on the thermowell shank construction and the fluid velocity. Should this frequency exceed the "natural frequency" of the thermowell, it will cause the thermowell to break off. It is therefore necessary that the thermowell selected be such that its "natural frequency" always exceeds the potential wake frequency caused by the process flow. Contact Global Customer Support for further details and if Wake Frequency calculations are required.

MODEL CODES

Model TF Flanged Wells

Description	Model
Flanged Well	TF
<b>Internal Diameter</b>	
0.260 in (6.6 mm)	-2
<b>Material</b>	
316 ss	C
<b>Flange Size</b>	
1 in	C
1 1/2 in	D
2 in	E
<b>Flange Rating</b>	
ANSI Class 150	A01
ANSI Class 300	A03
ANSI Class 600	A06
<b>Shank Type</b>	
Straight (a)	2
Stepped (b)	3
Tapered	4
<b>Insertion Length U (c)</b>	
2.0 in (51 mm)	020
2.5 in (64 mm)	025
3.0 in (76 mm)	030
3.5 in (89 mm)	035
4.0 in (102 mm)	040
4.5 in (114 mm)	045
5.0 in (127 mm)	050
to 36 in in 0.5 in increments (to 914 mm in 12.7 mm increments)	
36.0 in (914 mm)	360
<b>Lagging Length T</b>	
0.0 (None)	00
2.0 in (51 mm)	20
2.5 in (64 mm)	25
3.0 in (76 mm)	30
3.5 in (89 mm)	35
4.0 in (102 mm)	40
Example: TF-2CCA01303000	

- Straight shank wells are not recommended when the U-length exceeds 6 in (152 mm). In this case, a stepped shank will be provided at U-lengths of 6 in (152 mm) or greater. Contact Global Customer Support if a variation in the 6 in (152 mm) dimension is required.
- Stepped shanks are only available with U length codes 030 to 360 (U-lengths > 2.5 in or > 64 mm).
- U length is from the raised face of the flange to the well tip.

Model TT Threaded Wells

Description	Model
Threaded Well	TT
<b>Internal Diameter</b>	
0.260 in (6.6 mm)	-2
<b>Material</b>	
316 ss	C
<b>Process Connection Size</b>	
1/2 NPT	A
3/4 NPT	B
1 NPT	C
<b>Shank Type</b>	
Straight (a)	2
Stepped (b)	3
Tapered	4
<b>Insertion Length U (c)</b>	
2.0 in (51 mm)	020
2.5 in (64 mm)	025
3.0 in (76 mm)	030
3.5 in (89 mm)	035
4.0 in (102 mm)	040
4.5 in (114 mm)	045
5.0 in (127 mm)	050
5.5 in (140 mm)	055
6.0 in (152 mm)	060
6.5 in (165 mm)	065
7.0 in (178 mm)	070
7.5 in (191 mm)	075
to 36 in in 0.5 in increments (to 914 mm in 12.7 mm increments)	
36.0 in (914 mm)	360
<b>Lagging Length T</b>	
0.0 (None)	00
2.0 in (51 mm)	20
2.5 in (64 mm)	25
3.0 in (76 mm)	30
3.5 in (89 mm)	35
4.0 in (102 mm)	40
Example: TT-2CA203020	

- Straight shank wells are not recommended when the U-length exceeds 6 in (152 mm). In this case, a stepped shank will be provided at U-lengths of 6 in (152 mm) or greater. Contact Global Customer Support if a variation in the 6 in (152 mm) dimension is required.
- Stepped shanks are only available with U length codes 030 to 360 (U-lengths > 2.5 in or > 64 mm).
- U length is from below the threads to the well tip.



MODEL CODES

Model TW Weld-In Wells

Description	Model
Weld-In Well	TW
<b>Internal Diameter</b>	
0.260 in (6.6 mm)	-2
<b>Material</b>	
316 ss	C
<b>Process Connection Size</b>	
Nominal 3/4-inch Pipe (Socket Weld)	B
1.05-inch O.D. Well Connection	
Nominal 1-inch Pipe (Socket Weld)	C
1.315-inch O.D. Well Connection	
1.5-inch Diameter, Weld-in	D
<b>Shank Type</b>	
Straight (a)	2
Stepped (b)	3
Tapered	4
<b>Insertion Length U (c)</b>	
2.0 in (51 mm)	020
2.5 in (64 mm)	025
3.0 in (76 mm)	030
3.5 in (89 mm)	035
4.0 in (102 mm)	040
4.5 in (114 mm)	045
5.0 in (127 mm)	050
5.5 in (140 mm)	055
6.0 in (152 mm)	060
to 36 in in 0.5 in increments (to 914 mm in 12.7 mm increments)	
36.0 in (914 mm)	360
<b>Lagging Length T</b>	
0.0 (None)	00
2.0 in (51 mm)	20
2.5 in (64 mm)	25
3.0 in (76 mm)	30
3.5 in (89 mm)	35
4.0 in (102 mm)	40
Example: TW-2CB203020	

- Straight shank wells are not recommended when the U-length exceeds 6 in (152 mm). In this case, a stepped shank will be provided at U-lengths of 6 in (152 mm) or greater. Contact Global Customer Support if a variation in the 6 in (152 mm) dimension is required.
- Stepped shanks are only available with U length codes 030 to 360 (U-lengths > 2.5 in or > 64 mm).
- U length is from the raised face of the flange to the well tip.

Model TS Sanitary Wells

Description	Model
Sanitary Well	TS
<b>Internal Diameter</b>	
0.260 in (6.6 mm)	-2
<b>Material</b>	
316 ss	C
<b>Process Connection Size</b>	
3/4-inch Tri-Clamp	B
1-inch Tri-Clamp	C
1 1/2-inch Tri-Clamp	D
2-inch Tri-Clamp	E
3-inch Tri-Clamp	F
<b>Shank Type</b>	
Straight (a)	2
Stepped (b)	3
Tapered	4
<b>Insertion Length U (c)</b>	
2.0 in (51 mm)	020
2.5 in (64 mm)	025
3.0 in (76 mm)	030
3.5 in (89 mm)	035
4.0 in (102 mm)	040
4.5 in (114 mm)	045
5.0 in (127 mm)	050
5.5 in (140 mm)	055
6.0 in (152 mm)	060
6.5 in (165 mm)	065
7.0 in (178 mm)	070
7.5 in (191 mm)	075
to 36 in in 0.5 in increments (to 914 mm in 12.7 mm increments)	
36.0 in (914 mm)	360
<b>Lagging Length T</b>	
0.0 (None)	00
2.0 in (51 mm)	20
2.5 in (64 mm)	25
3.0 in (76 mm)	30
3.5 in (89 mm)	35
4.0 in (102 mm)	40
Example: TS-2CC203020	

- Straight shank wells are not recommended when the U-length exceeds 6 in (152 mm). In this case, a stepped shank will be provided at U-lengths of 6 in (152 mm) or greater. Contact Global Customer Support if a variation in the 6 in (152 mm) dimension is required.
- Stepped shanks are only available with U length codes 030 to 360 (U-lengths > 2.5 in or > 64 mm).
- U length is from the raised face of the flange to the well tip.

DIMENSIONS - NOMINAL

FLANGED - STRAIGHT SHANK THERMOWELLS

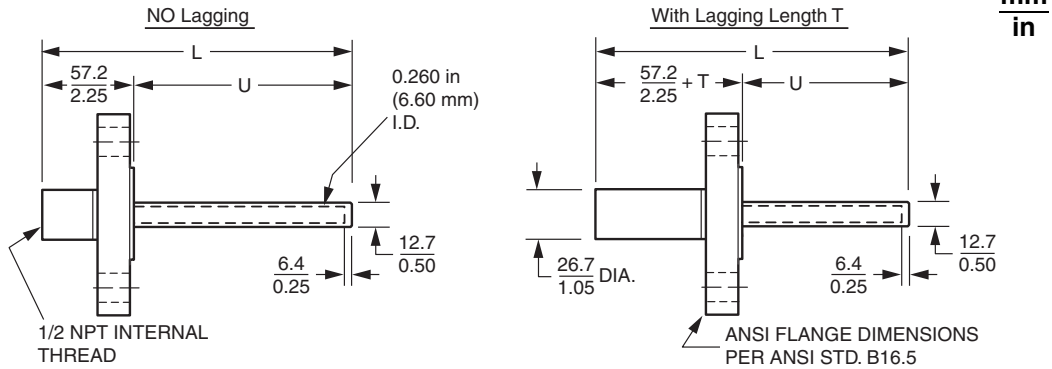

FLANGED - STEPPED SHANK THERMOWELLS

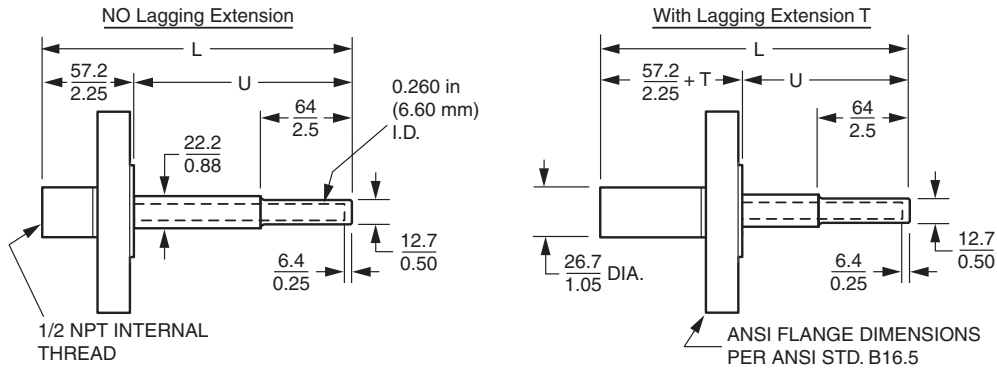

FLANGED - TAPERED SHANK THERMOWELLS

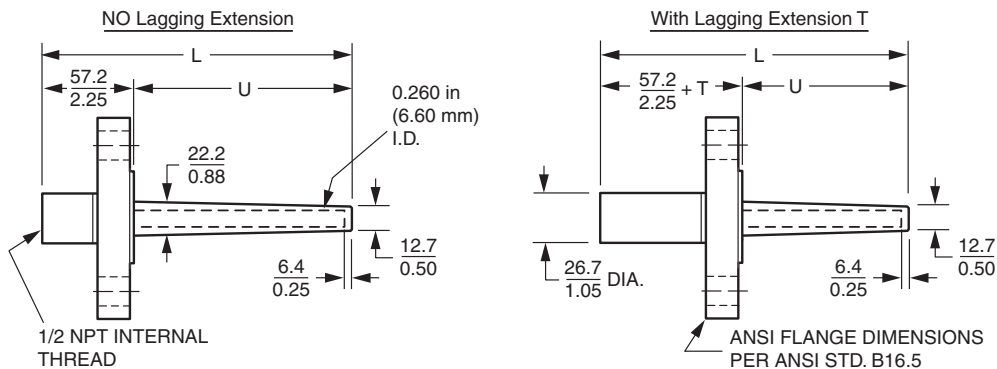

NOTE

- 1 Dimensions U and T (insertion length and lagging extension) are Model Code selections.
- 2 To determine the overall length L, use the following equations:  $L = 2.25 + T + U$  (inches); or  $L = 57.2 + T + U$  (millimeters)

- 3 For stepped shank wells, the U length must be greater than 2.5 in (64 mm).
- 4 Since straight shanks are not recommended for U-lengths greater than 6 in (152 mm), a stepped shank will be provided at U-lengths greater than 6 in (152 mm).

mm  
in

THREADED - STRAIGHT SHANK THERMOWELLS

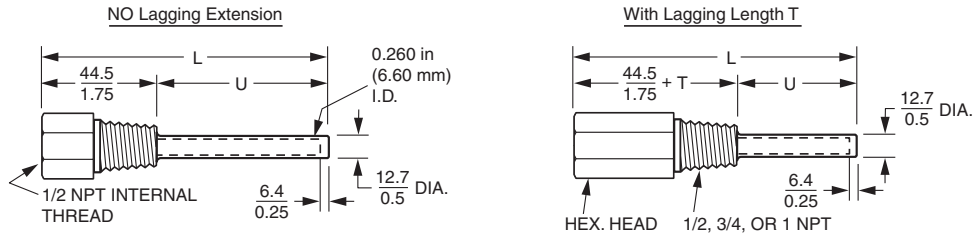

THREADED - STEPPED SHANK THERMOWELLS

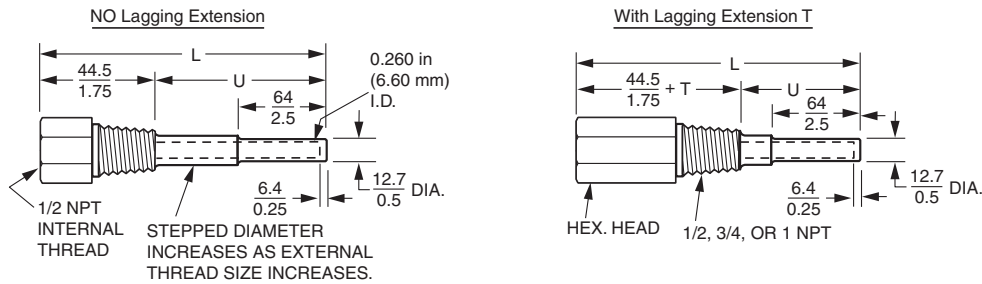

THREADED - TAPERED SHANK THERMOWELLS

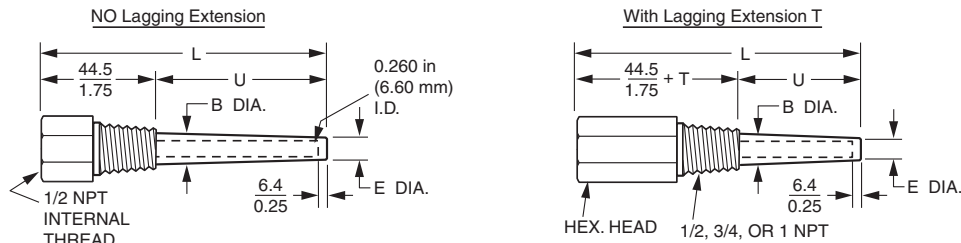

External Thread	Dimensions	
	E	B
1/2 NPT	12.7 0.50	16.0 0.63
3/4 or 1 NPT	16.0 0.63	22.4 0.88

NOTES

- Dimensions U and T (insertion length and lagging extension) are Model Code selections.
- To determine the overall length L, use the following equations:  
 $L = 2.25 + T + U$  (inches); or  $L = 57.2 + T + U$  (millimeters)
- For stepped shank wells, the U length must be greater than 2.5 in (64 mm).
- Since straight shanks are not recommended for U-lengths greater than 6 in (152 mm), a stepped shank will be provided at U-lengths greater than 6 in (152 mm).

mm  
in

WELD-IN - STRAIGHT SHANK THERMOWELLS

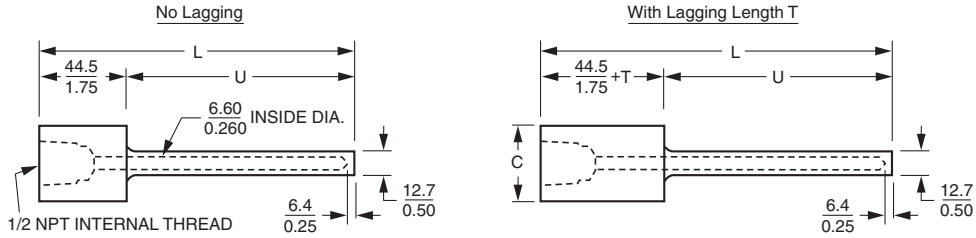

WELD-IN - STEPPED SHANK THERMOWELLS

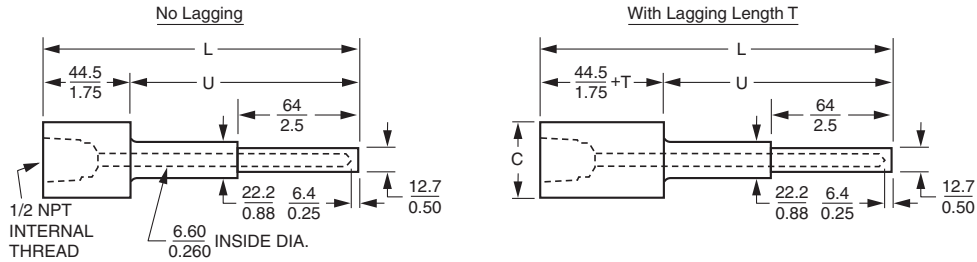

WELD-IN - TAPERED SHANK THERMOWELLS

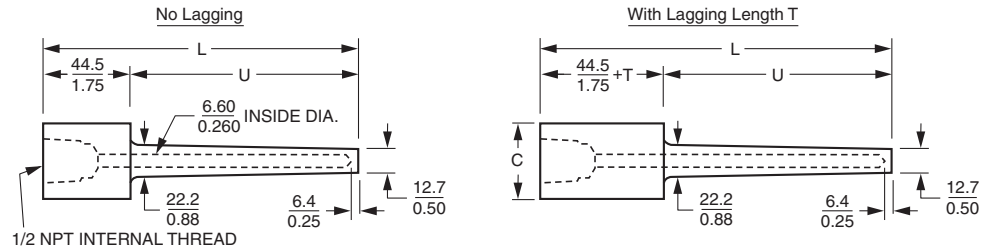

Code	C Diameter	Process Connection
B	$\frac{26.7}{1.05}$	Nominal 3/4 inch Pipe Socket Weld
C	$\frac{33.40}{1.315}$	Nominal 1 inch Pipe Socket Weld
D	$\frac{38.1}{1.50}$	1.5-inch Diameter, Weld-in

NOTES

- Dimensions U and T (insertion length and lagging extension) are Model Code selections.
- To determine the overall length L, use the following equations:  
 $L = 2.25 + T + U$  (inches); or  $L = 57.2 + T + U$  (millimeters)
- For stepped shank wells, the U length must be greater than 2.5 in (64 mm).
- Since straight shanks are not recommended for U-lengths greater than 6 in (152 mm), a stepped shank will be provided at U-lengths greater than 6 in (152 mm).

SANITARY - STRAIGHT SHANK THERMOWELLS

mm  
in

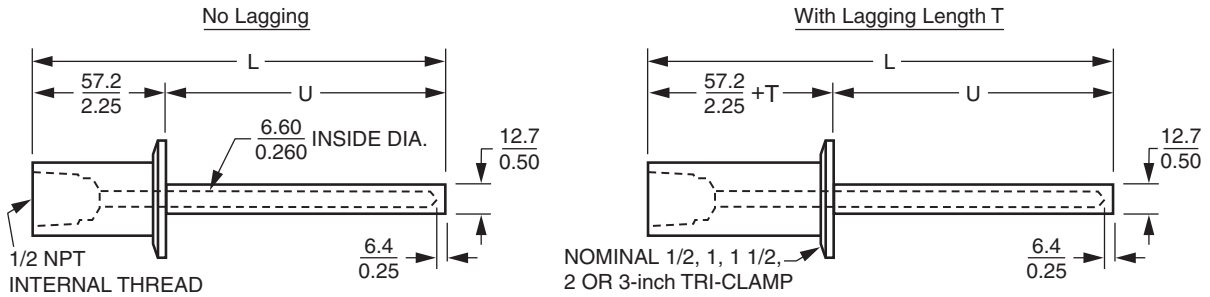

SANITARY - STEPPED SHANK THERMOWELLS

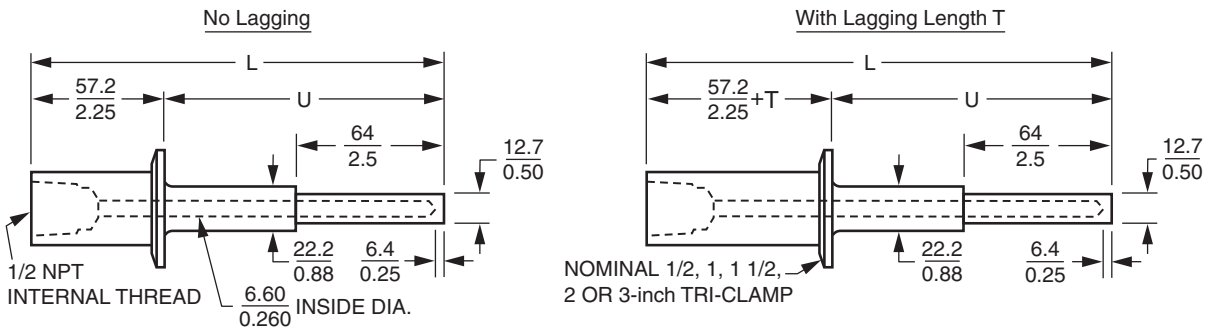

SANITARY - TAPERED SHANK THERMOWELLS

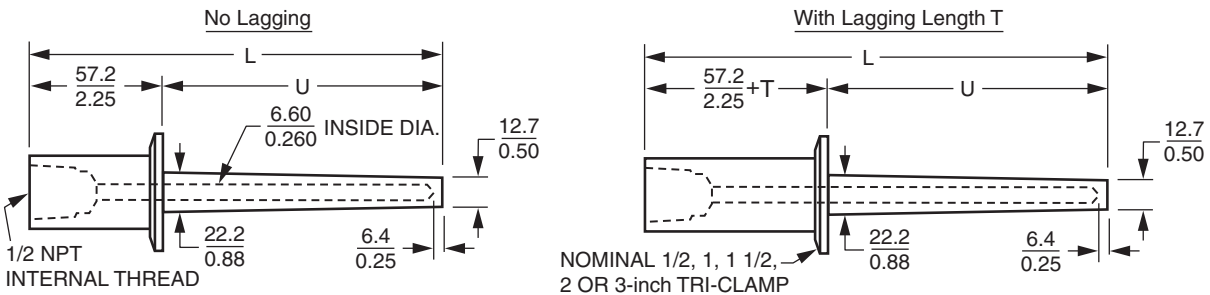

NOTES

- 1 Dimensions U and T (insertion length and lagging extension) are Model Code selections.
- 2 To determine the overall length L, use the following equations:  
 $L = 2.25 + T + U$  (inches); or  $L = 57.2 + T + U$  (millimeters)
- 3 For stepped shank wells, the U length must be greater than 2.5 in (64 mm).
- 4 Since straight shanks are not recommended for U-lengths greater than 6 in (152 mm), a stepped shank will be provided at U-lengths greater than 6 in (152 mm).

**NOTES**



## ORDERING INSTRUCTIONS

1. Model Number
2. Wake Frequency Calculations.  
See Recommended Well Applications section, and contact Global Customer Support.
3. Tag and Application

## OTHER FOXBORO PRODUCTS

The Foxboro product lines offer a broad range of measurement and instrument products, including solutions for pressure, flow, analytical, temperature, positioning, controlling, and recording. For a list of these offerings, visit our web site at:

[www.fielddevices.foxboro.com](http://www.fielddevices.foxboro.com)