

SRP981 气动阀门定位器 Pneumatic Positioner

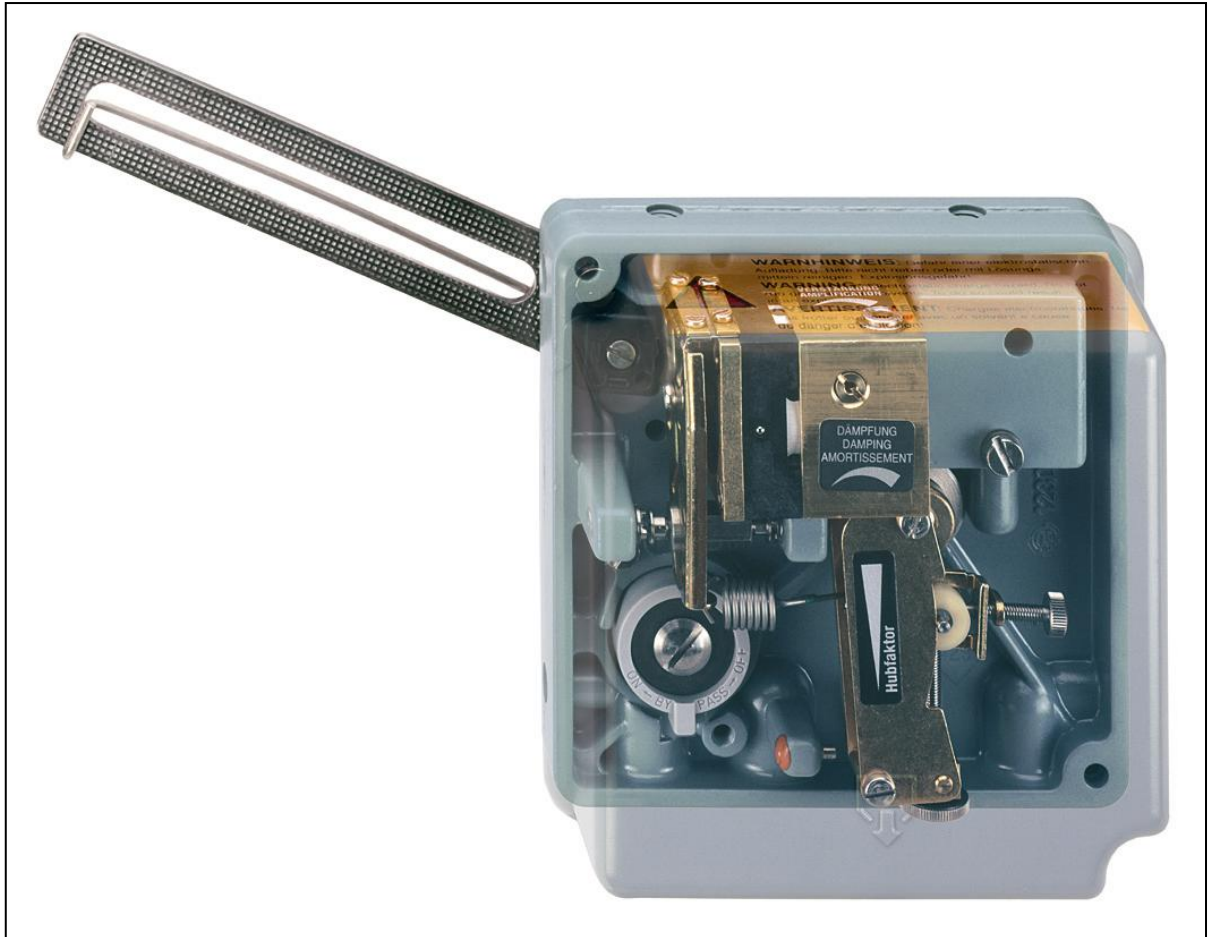

快速指导..... (中文版)

Quick Guide (English)







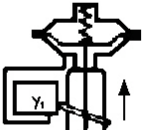

SRP981 气动阀门定位器

此说明书是用于使定位器快速启动的指导。如果需要更多具体的信息，请参见标准文件“主说明书”和“产品规格单”。这些文件可以在我公司的网站找到。

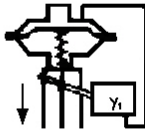
1 安装到线形执行机构上

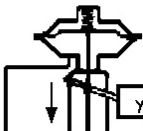
单作用执行机构隔膜阀





检查执行机构是否在工艺要求的安全位置上。（在弹簧力作用下执行机构是开或关？）。安装位置的选择依照当输入信号增大时的作用方向和所要求阀杆运动的方向来决定，请参见下表。

| Actuator closes with spring force | Changeover plate setting | Actuator opens with spring force | Changeover plate setting |
|--|--|--|---|
|  |  |  |  |
|  |  |  |  |

箭头表示输入信号增大时阀杆运动的方向。
输入信号的作用方向可通过转换板13来设置：
N = 正常的作用方向（输入信号增大，产生对执行机构的控制压力增大。）
U = 相反的作用方向（输入信号增大，产生对执行机构的控制压力减少）

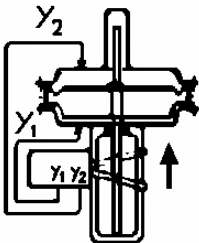
双作用执行机构隔膜阀

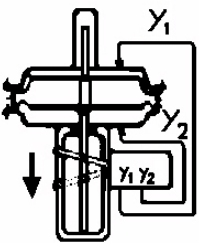
对于双作用定位器，转换板13总是设定在“N”的位置上。输入信号后执行机构主轴的运动方向是由定位器安装的位置和定位器对执行机构输出信号的管路来决定的。

| | Changeover plate setting | | Changeover plate setting |
|---|---|---|---|
|  |  |  |  |



保证反馈杆11在50%的行程时是水平的。

将盖子盖紧，使连接设备的的气孔面朝下（见标志‘M’）

M

12

11

2 安装到角行程执行机构上

- a) 从带有附件的外壳上移开透明盖板。
- b) 将带有附件的外壳安装到角行程执行器或电枢上；如有必要，请使用执行机构制造商提供的安装硬件。
- c) 移动执行机构到期望的开始位置。（旋转角度 = 0°）

d) 依照执行机构的旋转方向安装凸轮24。线性凸轮紧紧的扣住执行机构的传动轴，于是在外壳内侧与凸轮之间X距离为2mm,然而在等百分比凸轮的情况下，X的尺寸为大约17.5 mm。

在反等百分比凸轮的情况下，X的尺寸为大约18 mm。

当使用等百分比凸轮和反向等百分比凸轮时，量程弹簧（黄色）EW420493013必须被安装在定位器上

- e) 紧固反馈杆30以使角行程执行机构安装到定位器的轴15上。

f) 将定位器安装到带有附件的外壳上。连接弹簧31到反馈杆30上并使凸轮从动件32抵住凸轮。把定位器用螺丝固定到带有附件的外壳上。安装线性凸轮和等百分比凸轮时，检查标记33是否指向凸轮从动件32的中心；否则需调整。

安装等百分比凸轮时，检查凸轮从动件是否在凸轮轮角起点的前面；否则需调整

- g) 最后安装反馈杆到定位器的轴上，安装时行程在0%处，例如旋转角度为0°。首先通过孔34将反馈杆30的5 mm A/F六角固定螺丝松动，然后压行程系数杆17到止位螺钉18（见第5页）并紧固六角固定螺丝。

注意！

如果执行机构移动到了底端位置，且凸轮的安装位置与执行机构的旋转方向不相符，在这种情况下，请以反向位置安装凸轮24。

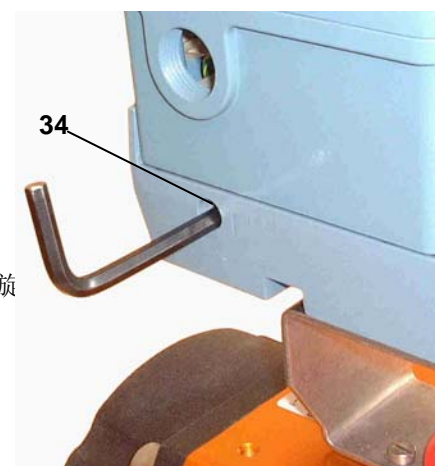
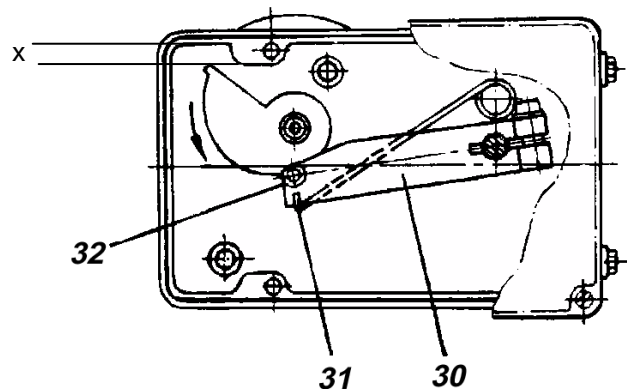
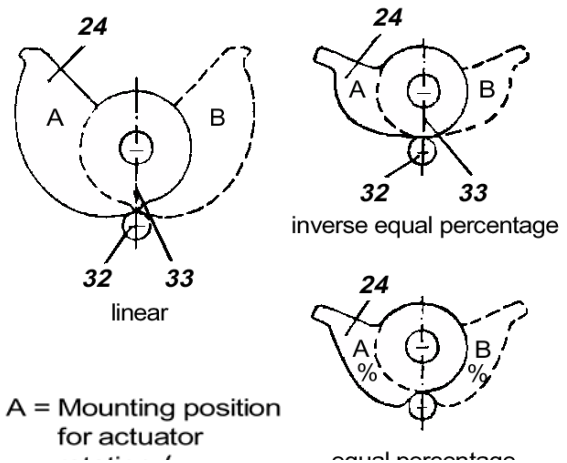
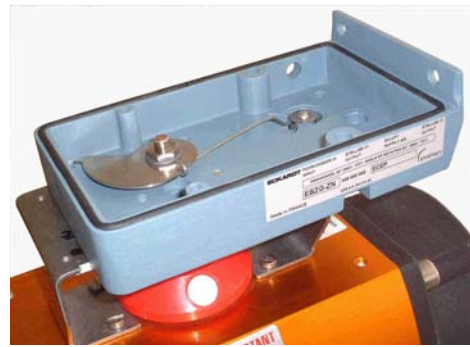

3 气动连接

气源: 1,4 to 6 bar (但不能大于执行机构的最大压力), 无油、灰尘和水!

4 气动输入信号(w)

6 内螺纹 G1/8 用于输出 II (y2)
(只在双作用定位器上)

7 内螺纹 G 1/8 用于供气

8 内螺纹 G 1/8 用于输出 I (y1)

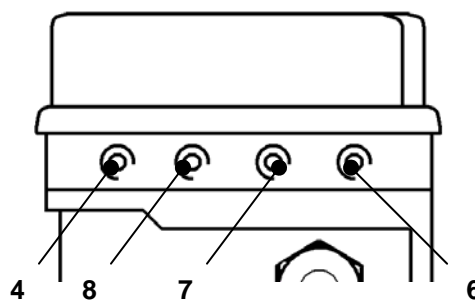

4 可选电气连接

必须遵守文件 EX EVE0001 的安全要求以及 SRP981 定位器的 PSS EVE0101 和 MI EVE0101 文件的要求

4.1 可选“限位开关”

限位开关是既可在出厂前安装又可更新的附件。此设备由感应槽型传感器或微动开关组成。

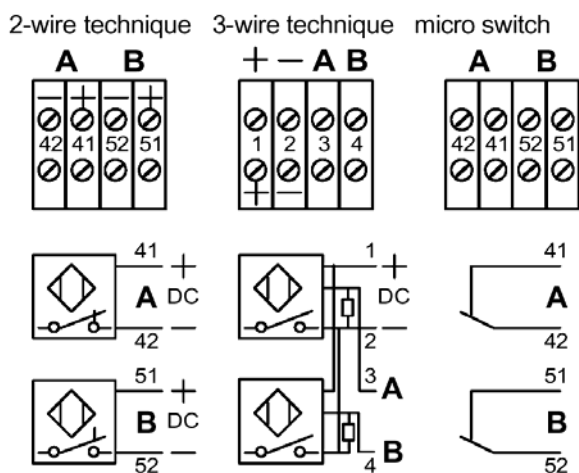

警告: 微动开关的连接, 请参阅 MI (主说明书) 和文件 EX EVE0001 中的相关安全要求

4.2 可选“位置变送器4-20 mA”

电气位置变送器是既可在出厂前安装又可更新的附件。它可将执行机构的直行程或角行程运动转换成为一个标准的4-20 mA电信号。

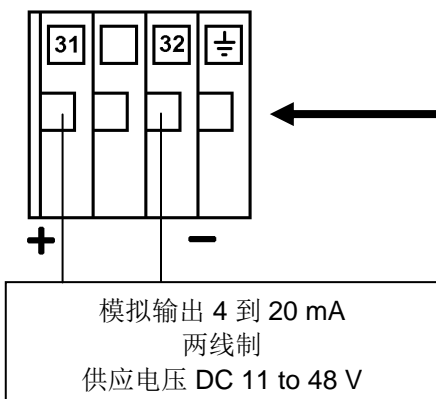

5 设置和启动

5.1 在定位器上设置零点和行程

(参见第5页中的数量)

在启动之前，向左右方向交替按挡板40几次以使挡板正确的对齐。

- 设定输入信号w的最小值（行程起点）
- 旋拧零点螺钉41直到执行机构开始从它的零点移动。
- 设定输入信号w的最大值（行程终点）。
- 旋拧行程系数螺钉42直到执行机构精确的到达它的终点位置。

向右旋拧:减少行程

向左旋拧:增大行程

重复操作（a到d步骤）2至3次以保证准确定位。

注意:

改变增益将影响零点和行程的设置。

如果以现有安装的弹簧无法调节行程，那么可以在第5页表格中的选择适合的弹簧。

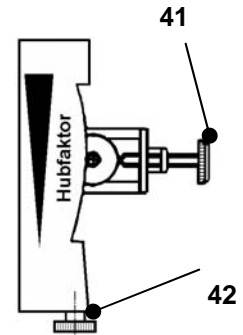

5.2 设置阻尼

可以通过调整阻尼螺丝46的方式来减缓定位器的气体输出。双作用定位器被安装了阻尼螺丝47和48以分别校正变量y1和变量y2。在正常设定时，阻尼螺丝与放大器本体大约在一个齐平位置上。

当阻尼螺丝被完全拧开时，气体输出能力减少大约为系数2.5。

5.3 设置和位置变送器4-20 mA启动

连接执行机构的附件和设备的启动必须遵照文件 MI EVE0101 A 来完成。在 50%的行程时，控制杆必须是平行的

必须保证位置变送器的电气连接。然后所有 LED's 指示灯才会点亮。

校准测量范围的起点(4 mA)

- 将执行机构移动到开始的位置。
- 按下 S1 “配置 4 mA 输出” 按钮，时长大于 2 秒种。此时，LED1 点亮。2 秒钟后，两个 LED's 指示灯再次点亮，4 mA 的值被存储下来。

校准测量范围的终点(20mA)

- 将执行机构移动到终点的位置。
- 按下 S2 “配置 20 mA 输出” 按钮，时长大于 2 秒种。此时，LED2 点亮。2 秒钟后，两个 LED's 指示灯再次点亮，20 mA 的值被存储下来。

在终点位置任意校准电流值。

- 将执行机构移动到终点的位置，您期望在此位置校准电流。
- 同时按下两个按钮大于 2 秒钟时间。然后两个 LED's 指示灯以较慢的频率交替闪烁。
- 通过按 S1 “配置 4 mA 输出” 按键，输出电流值将减少，通过按 S2 “配置 20 mA 输出” 按键，输出电流值将增大。短暂持续按下按键会产生很小的电流值变化，长时间按下按键会以一个快速模式产生很大的电流值变化。电流值可以自由的减少到 3.3 mA,最高增加到 22.5 mA.
- 不需任何的按键附加操作，新的电流值会自动被存储起来。几秒钟后，两个 LED's 指示灯再次点亮，说明该设备回到了正常操作模式。

位置变送器的检修

所安装的微型控制器持续监测位置变送器的各个部件。当两个 LED's 指示灯同时熄灭或同时高速平行闪烁，故障就被检测并指示出来了。

如果出现重大故障，例如电位计没有被连接，那么除了 LED's 指示出故障以外（快速闪烁），一个大于 24 mA 的输出电流将被显示出来。

在此情况下，检查是否发生下列事件：

- 电位计是否被正确的连接到电路板上。
- 电位计的工作量程是否有错。

当两个 LED's 熄灭时，应检查电源电压（最小电压，正负极）。

5.4 弹簧量程

五种不同量程范围的弹簧可以匹配行程和输入信号范围。

下列表格中给出了在正常应用情况下（4-20 mA 电信号和我公司的标准反馈杆）的行程范围。

| 弹簧量程 | | 行程范围 mm | 备注 |
|-------------|-------|----------|----|
| 识别号 | 颜色 | | |
| EW420493013 | 黄色 | 8 - 34 | |
| EW420494019 | 绿色 | 17 - 68 | 内置 |
| EW502558017 | - 无 - | 28 - 105 | |
| EW420496011 | 灰色 | 40 - 158 | |
| EW420495014 | 蓝色 | 55 - 200 | |

5.5 功能设计

Single acting positioner SRP981

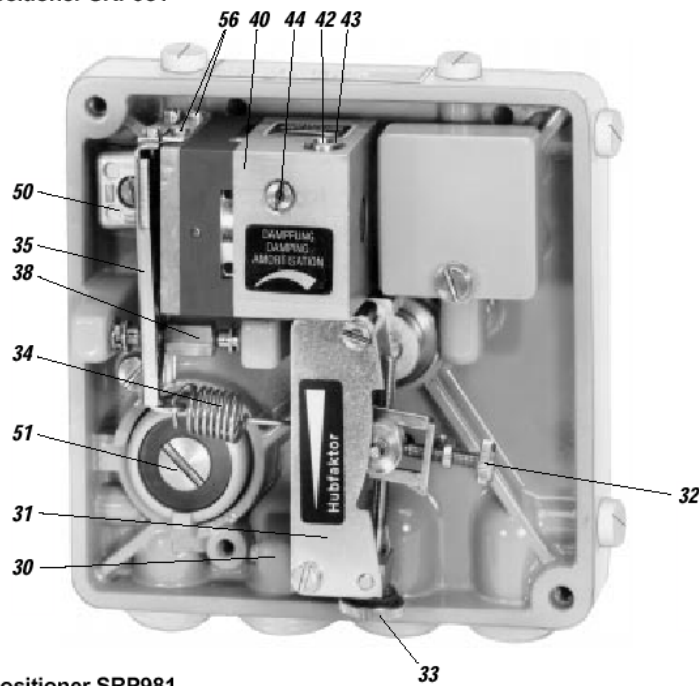

Double acting positioner SRP981

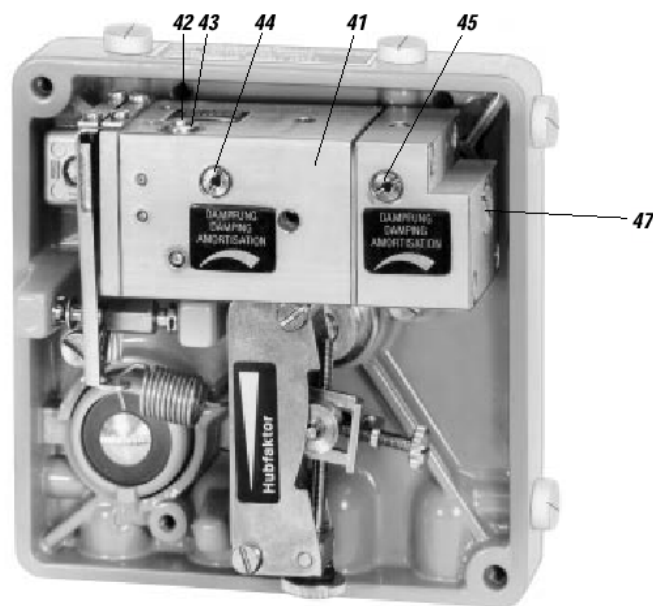

Invensys Systems, Inc.
38 Neponset Street
Foxboro, MA 02035
United States of America

schneider-electric.com

Global Customer Support
Toll free: 1-866-746-6477
Global: 1-508-549-2424
Website:
<http://support.ips.invensys.com>

Copyright 2010-2016 Invensys Systems, Inc.
All rights reserved.
Invensys, Foxboro, and I/A Series are trademarks of Invensys Limited, its subsidiaries, and affiliates. All other trademarks are the property of their respective owners.

DOKT 556 806 014
FD-QG-PO-007-CH

SRP981 PNEUMATIC POSITIONER

These instructions are to be used as a guide for quick start-up. For more detailed information please refer to the standard documents “Master Instructions” and “Product Specification Sheet”. These can be found on our Website.

1 MOUNTING TO LINEAR ACTUATORS

Single-acting diaphragm actuators

Check whether the actuator is in the safety position required by the process. (Does the actuator open or close with spring force?) The mounting side is selected from the table below in accordance with the direction of action and the required direction of movement of the spindle for an increasing input signal.

| Actuator closes with spring force | Changeover plate setting | Actuator opens with spring force | Changeover plate setting |
|-----------------------------------|--------------------------|----------------------------------|--------------------------|
| | | | |
| | | | |

The arrow indicates the direction of movement of the spindle at increasing input signal.

The direction of action of the input signal can be set on the changeover plate **13** :
 N = Normal direction of action (increasing input signal produces increasing control pressure to the actuator)
 U = Reverse direction of action (increasing input signal produces decreasing control pressure to the actuator)

Double-acting diaphragm actuators

For double-acting positioners the changeover plate **13** always stays in the “N” setting. The assignment of the input signal to the direction of movement of the actuator spindle is determined by the selection of the mounting side of the positioner and the piping of the positioner outputs to the actuator:

| | Changeover plate setting | | Changeover plate setting |
|--|--------------------------|--|--------------------------|
| | | | |

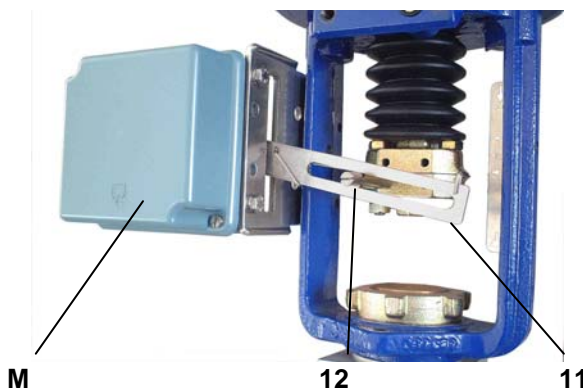

Ensure that the feedback lever **11** is horizontal at 50 % stroke.

Fasten housing cover in such a way that air vent of attached device faces downwards (see Mark ‘M’).

2 MOUNTING TO ROTARY ACTUATORS

- a) Remove the transparent cover plate from the housing of the attachment kit.
- b) Mount the housing of the attachment kit on rotary actuator or armature; use mounting hardware supplied by the actuator manufacturer if necessary.
- c) Move actuator into the desired starting position (rotation angle = 0°).



- d) Mount cam **24** in accordance with the direction of rotation of the actuator.

The linear cam is fastened to the actuator drive shaft in such a manner that the distance x between the inside of the housing and the came amounts 2 mm, whereas in case of equal percentage cam the dimension x is approx. 17.5 mm.

In case of inverse equal percentage cam the dimension x is approx. 18 mm.

When employing equal percentage and the inverse equal percentage cams, the range spring (yellow) EW420493013 must be installed in the positioner.

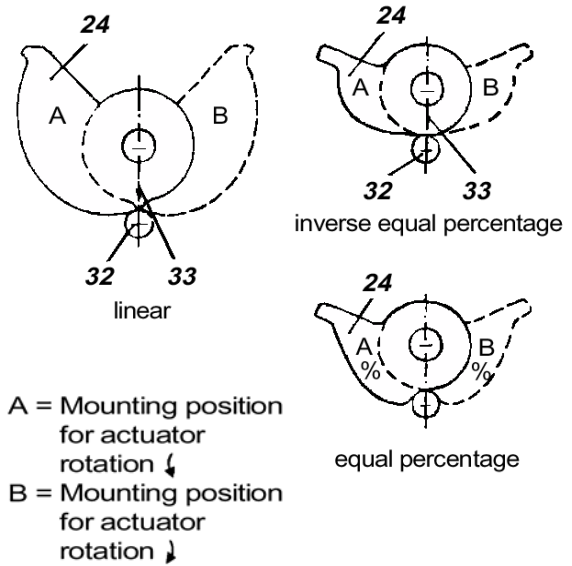

- e) Fasten feedback lever **30** for the rotary actuator onto shaft **15** of positioner.

- f) Mount positioner on housing of attachment kit. Attach spring **31** to feedback lever **30** and cam follower **32** against cam.

Screw positioner to housing of attachment kit. With the linear cam and the inverse equal percentage cam check whether mark **33** points to the center of the cam follower **32**; adjust if necessary.

With the equal percentage cam check whether the cam follower lies directly ahead of the start of the cam lobe; adjust if necessary.

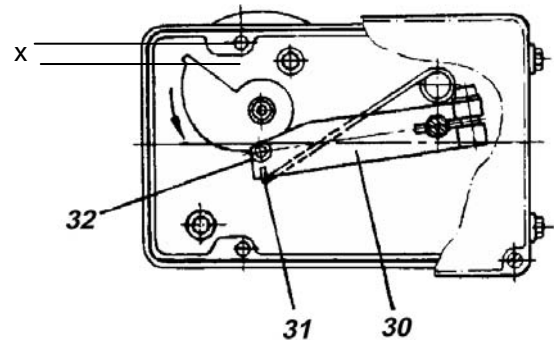

- g) Final mounting of feedback lever on shaft of positioner is performed at a stroke of 0 %, i.e. a rotation angle of 0°. First loosen 5 mm A/F Allen screw of feedback lever **30** through hole **34**, then press stroke factor lever **17** against stop screw **18** (see page 5) and tighten Allen screw firmly.

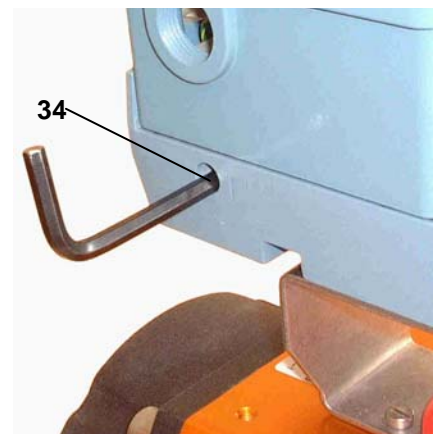

Note !

If actuator moves to an end position, the mounting position of cam does not coincide with the direction of rotation of the actuator. In this case install the cam **24** in the reverse position.

3 PNEUMATIC CONNECTIONS

Air supply (s): 1,4 to 6 bar (but not more than the max. pressure of actuator), free of oil, dust and water !

- 4 Pneumatic input signal (w)
- 6 Internal thread G 1/8 for output II (y2)
(only on double-acting positioners)
- 7 Internal thread G 1/8 for supply air
- 8 Internal thread G 1/8 for output I (y1)

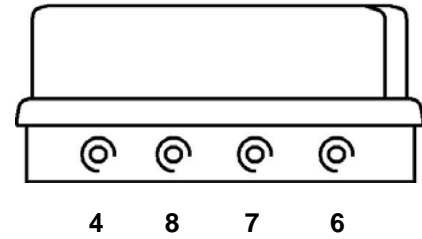

Air supply according to ISO 8573-1
 - Solid particle size and density class 2
 - Oil rate class 3
 Pressure dew point 10 K below ambient temperature

4 ELECTRICAL CONNECTIONS OF OPTION

The safety requirements of the document EX EVE0001 as well as the requirements of the PSS EVE0101 and MI EVE0101 for the SRP981 must be observed

4.1 Option “Limit switch”

The limit switches is an accessory either installed in the factory or retrofit. This unit can consist of either inductive slot type sensors or micro switches.

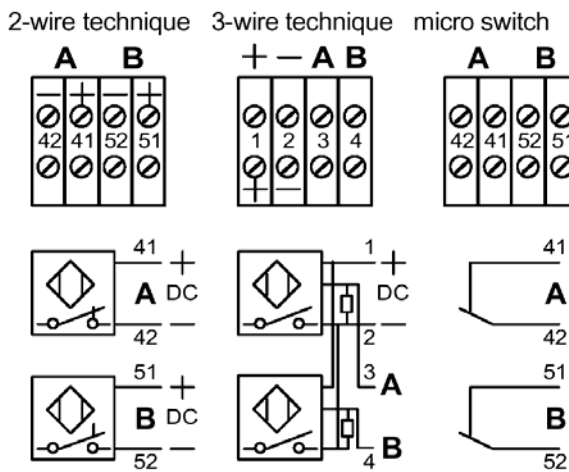

Warning : For the connection of micro-switches please refer you to the MI (Master Instruction) and respect the safety requirements of the document EX EVE0001.

4.2 Option “Position Transmitter 4-20 mA”

The electrical position transmitter is an accessory either installed in the factory or retrofit. It converts the stroke or rotary movement of an actuator into an electrical standard signal 4-20 mA.

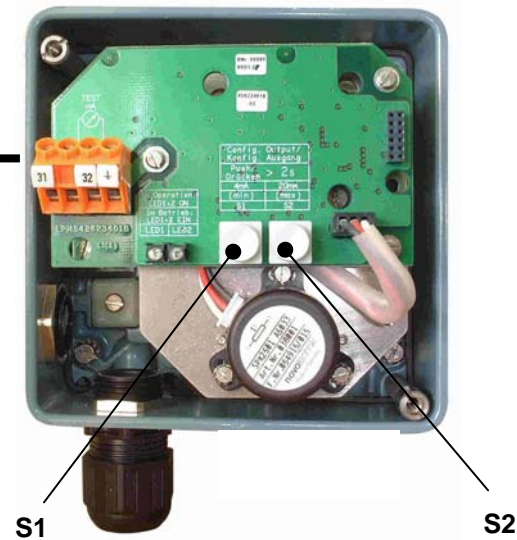
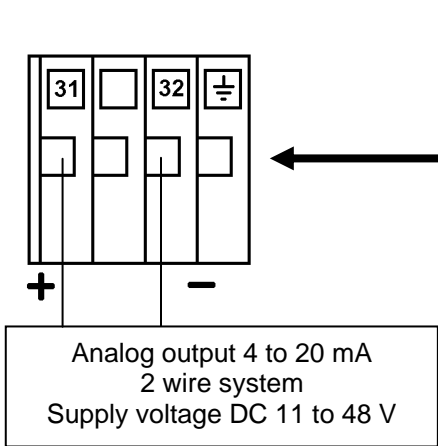

5 SETTINGS AND START UP

5.1 Setting of zero point and stroke on the positioner

(see page 5 for the reference of the number)

Before starting with the set-up push the flapper lever **40** several times alternately to the left and right in order to align the flappers correctly.

- Set the minimum value of the input signal w (start of stroke).
- Turn zero screw **41** until actuator just begins to move from its end position.
- Set maximum value of the input signal w (end of stroke).
- Turn the stroke factor screw **42** until actuator precisely reaches its end position:

Right turn: decrease of travel

Left turn: increase of travel

Repeat the operations (a to d) 2 or 3 times in order to insure an accurate positioning.

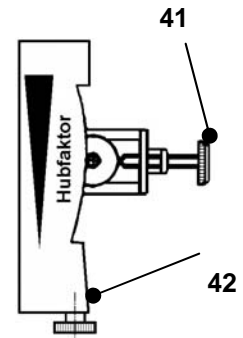

Note:

Changes of the gain will influence the settings of zero and span.

If the stroke cannot be adjusted with the installed spring, a suitable spring can be determined with the table on page 5.

5.2 Setting the damping

The air output capacity of the positioner can be reduced by means of the damping throttle **44**. Double-acting positioners are equipped with a damping throttle **44** for correcting the variable y_1 and a damping throttle **45** for correcting the variable y_2 . In its normal setting the damping throttle is approximately flush with the amplifier housing.

The air output capacity is reduced by a factor of approximately 2.5 when the damping throttle is turned completely.

5.3 Setting and Start Up of position transmitter 4-20 mA

Attachment and start-up of the unit to the actuator must be performed according MI EVE0101 A. At 50% stroke, the control lever must be horizontal.

The electronic connection of the position transmitter must be assured. Both LEDs are then light up.

Adjusting the start of the measuring range (4 mA)

- Move the actuator to the starting position.
- Press push button S1 „Config Output 4 mA“ longer than 2 seconds. During this time LED 1 lights up. After 2 seconds both LEDs are light up again, the value for 4mA is stored.

Adjusting the end of the measuring range (20 mA)

- Move the actuator to the end position.
- Press push button S2 „Config Output 20 mA“ longer than 2 seconds. During this time LED 2 lights up. After 2 seconds both LEDs are light up again, the value for 20 mA is stored.

Random adjustment of the current values at the end points

- a) Move the actuator to the end position, where you want to adjust the current.
- b) Press both buttons simultaneously for about 2 seconds. Then both LEDs are alternating flashing in a slow frequency.
- c) With push button S1 „Config Output 4 mA“ the output current value can be decreased and with push button S2 „Config Output 20 mA“ the output current value can be increased. Pressing the buttons for a short moment results in a small change and pressing the button for a longer time results in a fast mode for a bigger change. The value of the current can be freely decreased between about 3.3 and increased up to 22.5 mA.
- d) Without any additional manipulations of the push buttons the new value is automatically saved. After a few seconds, the device returns into the normal operating mode, indicated by both LEDs that are then light up again.

Trouble shooting of the position transmitter

The components of the position transmitter are under constant surveillance by the installed micro controller. Errors are detected and indicated when both LEDs are off or both LEDs are parallel flashing at a fast frequency.

In the event of a fatal error, e.g. potentiometer not connected, an output current of more then 24 mA will be shown in addition to the error indication given by the LEDs (fast flashing).

In this case check the following:

- a) if the potentiometer is correctly connected to the electronic board.
- b) if the potentiometer is within its working span.

When both LEDs are off, the supply voltage should be checked (minimum tension, polarity).

5.4 Spring range

Five different springs for the travel ranges are available for matching to the stroke and input signal range. In the following table the stroke range is given for a normal application (4-20 mA and with our standard feedback lever).

| Spring range | | Stroke range in mm | Remarks |
|--------------|-------------|-----------------------|----------|
| Ident N° | Colour | | |
| EW420493013 | Yellow | 8 - 34 | |
| EW420494019 | green | 17 - 68 | Built-in |
| EW502558017 | - without - | 28 - 105 | |
| EW420496011 | gray | 40 - 158 | |
| EW420495014 | blue | 55 - 200 | |

5.5 Functional designation

Single acting positioner SRP981

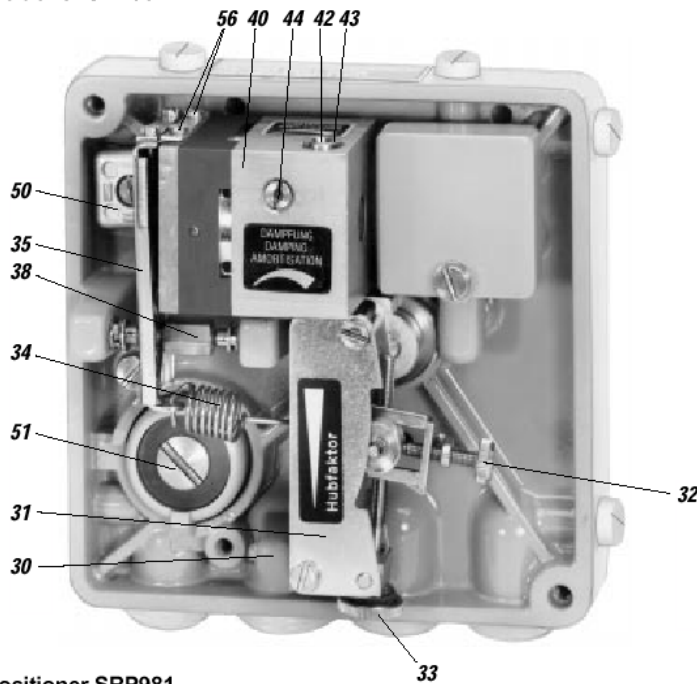

Double acting positioner SRP981

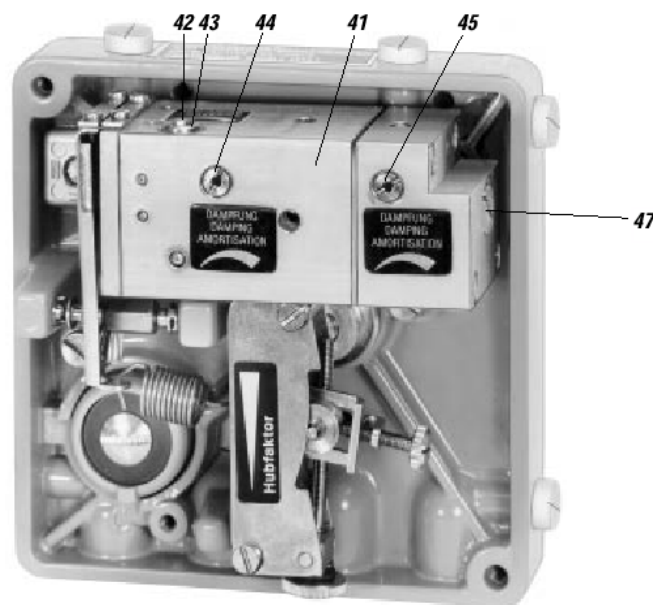

Invensys Systems, Inc.
38 Neponset Street
Foxboro, MA 02035
United States of America

schneider-electric.com

Global Customer Support
Toll free: 1-866-746-6477
Global: 1-508-549-2424
Website:
<http://support.ips.invensys.com>

Copyright 2010-2016 Invensys Systems, Inc.
All rights reserved.
Invensys, Foxboro, and I/A Series are trademarks of Invensys Limited, its subsidiaries, and affiliates. All other trademarks are the property of their respective owners.

DOKT 556 806 014
FD-QG-PO-007-EN

Life Is On

Foxboro
by Schneider Electric

Invensys Systems, Inc.
38 Neponset Street
Foxboro, MA 02035
United States of America

schneider-electric.com

Global Customer Support
Toll free: 1-866-746-6477
Global: 1-508-549-2424
Website:
<http://support.ips.invensys.com>

Copyright 2010-2016 Invensys Systems, Inc.
All rights reserved.
Invensys, Foxboro, and I/A Series are trademarks of Invensys Limited, its subsidiaries, and affiliates. All other trademarks are the property of their respective owners.

DOKT 556 806 014
FD-QG-PO-007-CH-EN

0316