

SRI983 Electro-Pneumatic Positioner
- Explosion Proof / Intrinsically Safe



The SRI983 Positioner is for operation of pneumatic valve actuators from control systems and electrical controllers with electric control signals. It is used to reduce the adverse effects of valve friction, for higher thrust and shorter positioning time.

FEATURES

- Independent adjustment of stroke range and zero
- Adjustable amplification and damping
- Split range up to 3-fold possible
- One version for 4-20 mA input
- Supply pressure up to 6 bar (90 psig)
- Low vibration effect in all directions
- Mounting according to IEC 534, part 6 (NAMUR)
- Rotation adapter for angles up to 120 °
- Mounting onto any linear or rotary actuator
- Explosion protection:
II 2 G Ex d and II 1 G Ex ia according to ATEX,
or explosion proof, intrinsic safety acc. to FM and
CSA, and CU TR
- EMC in accordance with the international standards
and laws (CE)

*Equipment should be installed, operated, serviced, and maintained only by qualified personnel.
No responsibility is assumed by Schneider Electric for any consequences arising from the use of this material.*

TABLE OF CONTENTS

CHAP: CONTENT	PAGE
1 GENERAL	3
1.1 Identification	3
1.2 Additional equipment	3
1.3 Function	4
2 MOUNTING	5
2.1 Dimensions	5
2.2 Attachment kit for diaphragm actuators .	6
2.2.1 Dimensions	6
2.2.2 Determination of mounting side.....	7
2.2.3 Attachment to diaphragm actuators	7
2.3 Attachment kit for rotary actuators	8
2.3.1 Dimensions	8
2.3.2 Attachment to rotary actuators	9
2.3.3 Reversing direction of rotation.....	10
2.4 Manual bypass switch	11
3 ELECTRICAL CONNECTIONS	11
4 START-UP	12
4.1 Setting the gain.....	12
4.2 Setting of zero point and stroke.....	12
4.3 Setting the damping.....	13
4.4 Subdivision of input range (split-range)	13
4.5 Determination of rotation angle factor U_{ϕ} .	14
4.6 Determination of stroke factor U_x	14
4.6.1 Stroke factor ranges of the range springs .	14
4.6.2 Characteristics of the range springs.....	15
5 MAINTENANCE	16
5.1 Basic adjustment of single acting positioner (pneumatic part).....	16
5.2 Basic adjustment of the double acting positioner (pneumatic part).....	17
5.3 Cleaning the throttle	18
5.4 Check and adjust I-p converter	18
6 TROUBLESHOOTING	19
7 REPLACING SUBASSEMBLIES	19
7.1 Replacing the amplifier	19
7.2 Replacing the amplifier diaphragm in the single acting positioner	20
7.3 Replacing the amplifier diaphragm in the double acting positioner.....	21

CHAP: CONTENT	PAGE
8 SAFETY REQUIREMENTS	22
8.1 Accident prevention	22
8.2 Electrical safety	22
8.2.1 General requirements.....	22
8.2.2 Regulations for Connection	22
8.2.3 Explosion protection	22
8.2.4 EMC and CE.....	22
PHOTOGRAPHS	23



1 GENERAL

The electro-pneumatic positioner is used for direct operation of pneumatic valve actuators by means of electrical controllers or control systems with an analog output signal of 4-20 mA or split ranges.

Fig. 1: Control circuit with single-acting positioner

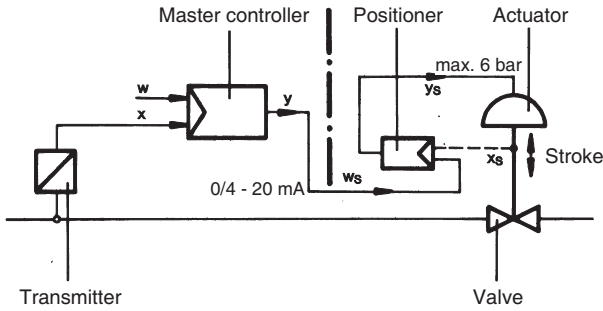

Positioner and pneumatic actuator form a control loop with the command variable w_s (output signal y of the master controller), the correcting variable y_s and the stroke position x_s of the actuator.

In this manner disturbing influences such as gland friction and medium forces within the valve are compensated by the positioner.

In addition, the positioning force of the actuator can significantly be increased by an output pressure of max. 6 bar.

The electro-pneumatic positioner can be mounted on both diaphragm actuators and rotary actuators.

For spring loaded actuators a single-acting positioner is used, whilst for actuators without spring loading a double acting positioner is used.

The double acting positioner operates with two opposing control pressures.

1.1 Identification

The nameplate of the positioner is located at the side wall of the housing. Nameplates are in accordance with selected model. Examples:

Explosion protection acc. to ATEX

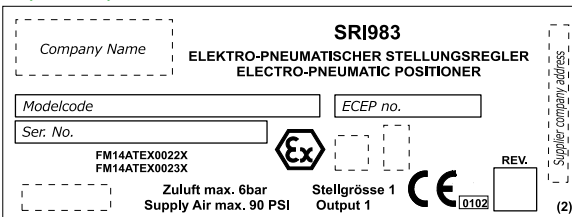

Explosion protection EAC approved

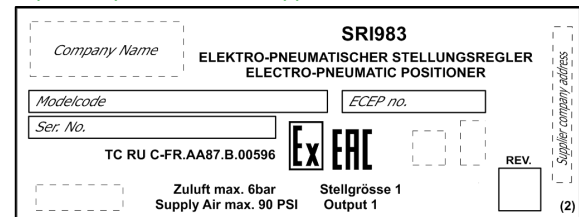

1.2 Additional equipment

Single acting positioners are available with two built-in gauges for the indication of the input value **10** and the actuating pressure **11** (output).

Fig. 4: Single-acting positioner with built-in gauges

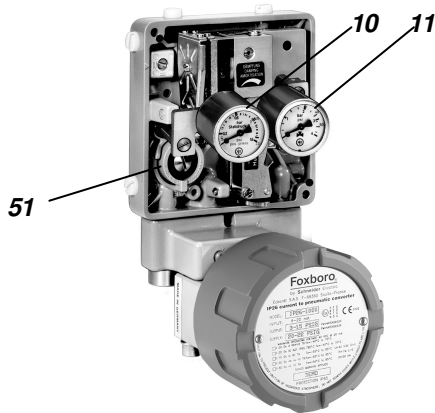

Manual bypass switch **51** for single-acting positioner only

For attachment to rotary actuators and rotary armatures an attachment-kit for rotary movement (Code EBZG-PN, -NN, -JN, -ZN, -RN) is required.

Fig. 5: Housing of the attachment kit for rotary movements

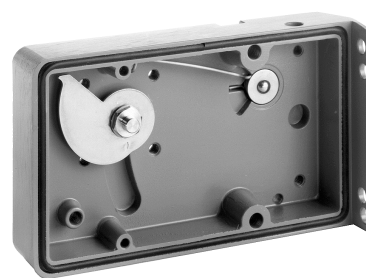

By means of a total of five range springs the positioner can be matched to nearly all operating situations, such as up to 4-way (or with 4 to 20 mA up to 3-way) range subdivision, very high and very short strokes and angles of rotation or special cams. A standard range spring 420 494 019 is installed.

Other range springs are available (see pages 14 and 15).

1.3 Function

The positioner operates according to the force comparison principle:

The input current signal w flows through coil **93**, which magnetizes the magnetic system **94**. The resulting magnetic field in gap **95** enforces a permanent magnet **96** proportional to input current.

Magnet **96** forms the rotating system together with impact plate **97**. Impact plate **97** more or less covers nozzle **98** whereby the dynamic pressure at nozzle **98** pursues a restorable force equalizing the force at magnet **96** in balance. Nozzle **98** is supplied with air via throttle **92** from output pressure w' of the amplifier **99** driven by the change in pressure ahead of nozzle **98**.

At the same time the pressure signal w' is passed to the input diaphragm **70**. The stroke of the input diaphragm is transferred to the flapper lever **54**. The resultant change in the distance between the nozzle **36** and the flapper **37** alters the back pressure at the nozzle. This pressure acts in a single acting positioner on an amplifier **40**. Its output pressure y results in a stroke movement of diaphragm actuator with spring resetting (see Fig. 6).

In the double acting positioner this pressure acts on a double acting amplifier **41**, where opposed output pressures y_1 and y_2 cause a stroke movement in the diaphragm actuator without spring resetting (see Fig. 7).

The stroke movement is tapped at the actuator spindle **16** of the feedback lever **9** and transferred to the stroke factor lever **31**. The stroke factor lever **31** and the flapper lever **54** are connected by the range spring **34**.

Equilibrium of forces is set at the flapper lever **54** if the torque produced at the input diaphragm **70** is equal to the torque reaction of the range spring **34** produced by the stroke setting. Thus an actuator setting proportional to the signal input is retained constantly.

A dynamic adaption to the actuator (sensitivity, stability) can be accomplished by the throttling screw **42** and the damping throttles **44**, **44** and **45** in the double acting positioner. The stroke range and zero point are set via the zero screw **32** and the stroke factor screw **33**.

A rising or falling actuator pressure at rising input signal is set in the single acting positioner by means of the changeover plate **50**.

Fig. 6: Single acting electro-pneumatic positioner

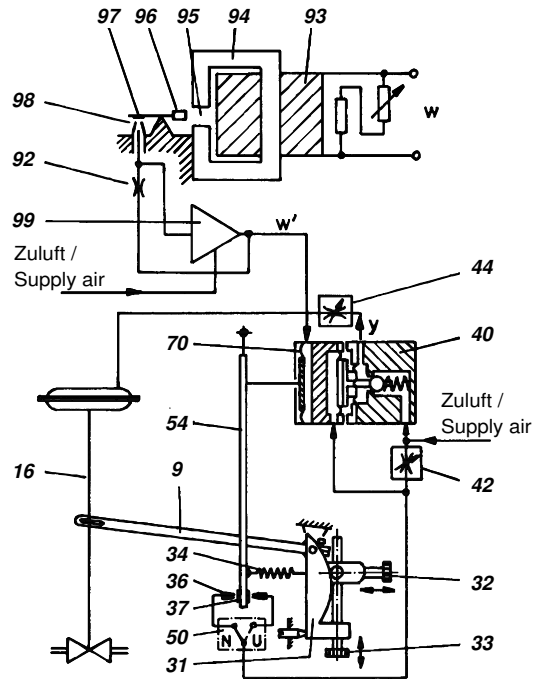
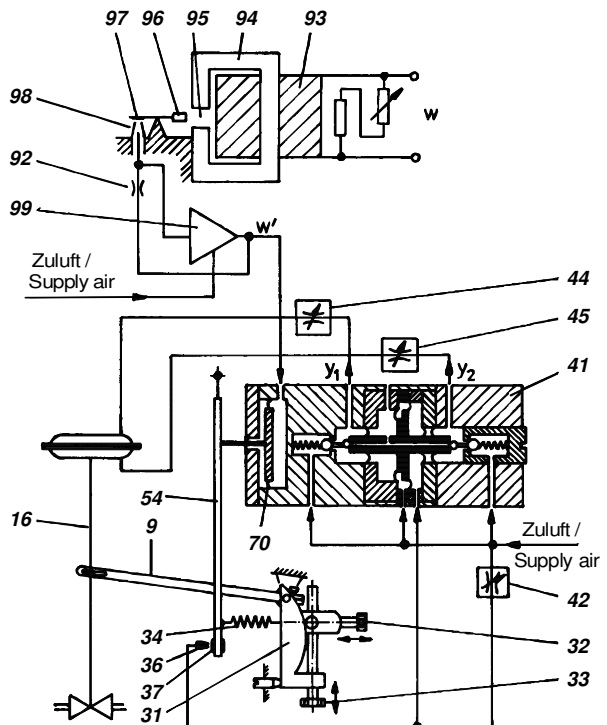
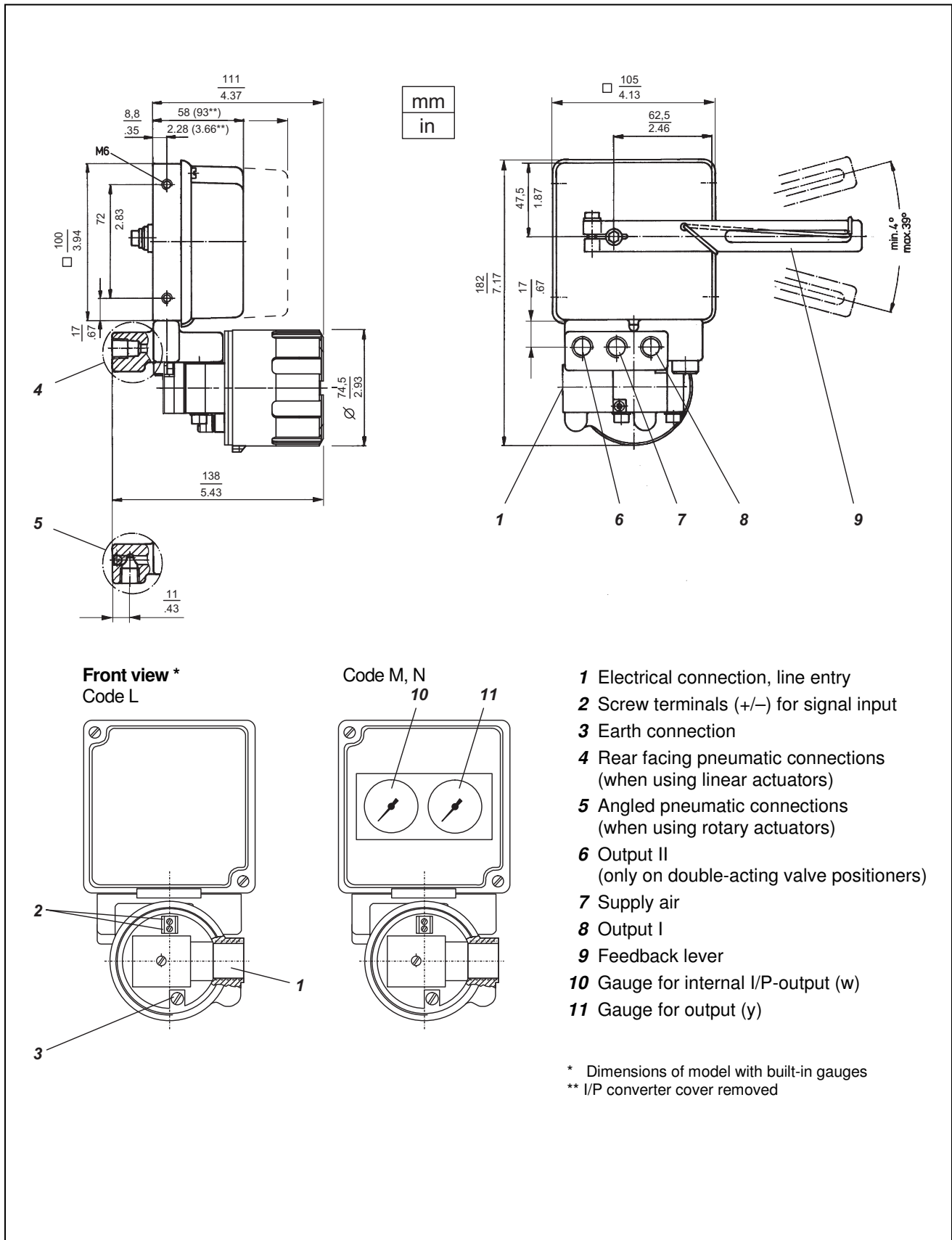

Fig. 7: Double acting electro-pneumatic positioner



2 MOUNTING

2.1 Dimensions



Front view *
Code L

Code M, N

- 1** Electrical connection, line entry
- 2** Screw terminals (+/-) for signal input
- 3** Earth connection
- 4** Rear facing pneumatic connections (when using linear actuators)
- 5** Angled pneumatic connections (when using rotary actuators)
- 6** Output II (only on double-acting valve positioners)
- 7** Supply air
- 8** Output I
- 9** Feedback lever
- 10** Gauge for internal I/P-output (w)
- 11** Gauge for output (y)

* Dimensions of model with built-in gauges
** I/P converter cover removed

ATTACHMENT KIT FOR DIAPHRAGM ACTUATORS

Attachment to casting yoke
according to IEC 534-6 (NAMUR)
Code EBZG-GN

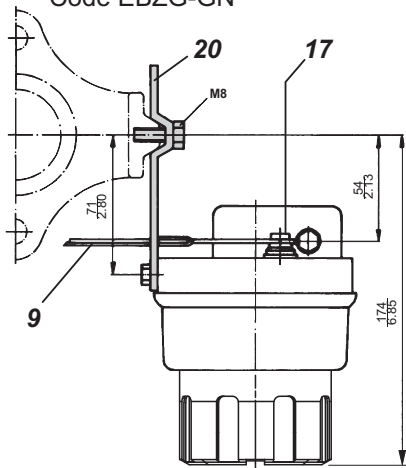

Attachment to pillar yoke
according to IEC 534-6 (NAMUR)
Code EBZG-FN

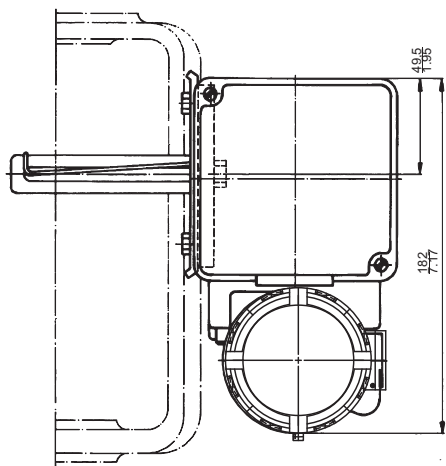
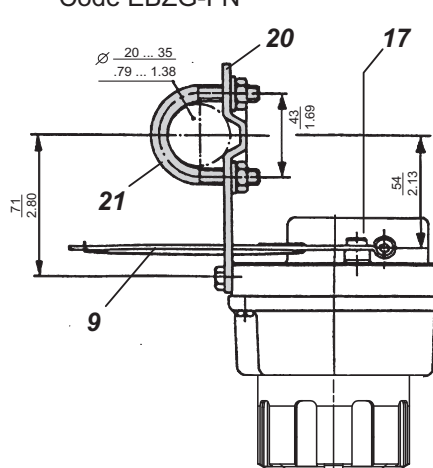

Mounting bracket
according to IEC 534-6 (NAMUR)
for Code EBZG-GN, FN

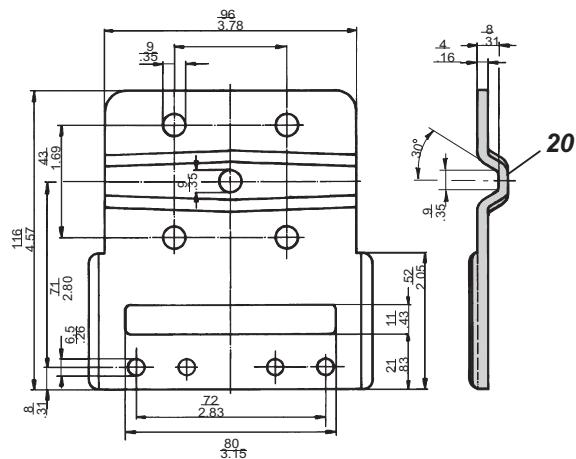

Feedback lever
Code EBZG-AN, -FN, -GN
Code EBZG-BN (extended version)

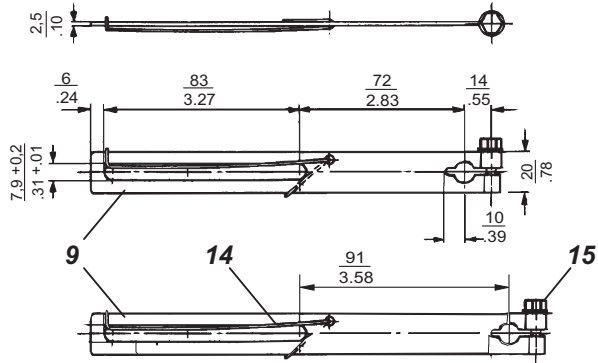

mm
in

Carrier bolt
for attachment to valve stem

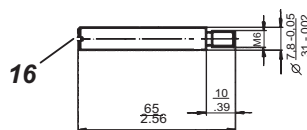

2.2.2 Determination of mounting side

Single acting diaphragm actuators

Check whether the actuator is in the safety position required by the process (Does the actuator open or close with spring force?).

The mounting side is selected from the table below in accordance with the direction of action and the required direction of movement of the spindle for an increasing input signal.

Actuator closes with spring force	Changeover plate setting	Actuator opens with spring force	Changeover plate setting

The arrow indicates the direction of movement of the spindle at increasing input signal.

The direction of action of the input signal can be set on the changeover plate **50** (see page 23):

N= Normal direction of action (increasing input signal produces increasing control pressure to the actuator)

U= Reverse direction of action (increasing input signal produces decreasing control pressure to the actuator)

Double acting diaphragm actuators

For double acting positioners the changeover plate **50** always stays in the "N" setting. The assignment of the input signal to the direction of movement of the actuator spindle is determined by the selection of the mounting side of the positioner and the piping of the positioner outputs to the actuator:

If the actuator spindle is to ascend with an increasing input signal, output y1 is connected at top of the actuator and output y2 is connected at bottom.

The positioner is mounted at the right hand side.

If the actuator spindle is to retract with an increasing input signal, output y1 is connected at bottom and output y2 at top of the actuator.

The positioner is mounted at the left hand side.

	Changeover plate setting		Changeover plate setting

The arrow indicates the direction of movement of the spindle with an increasing input signal.

2.2.3 Attachment to diaphragm actuators

Attachment of the positioner is made using the attachment kit for diaphragm actuators according to DIN IEC 534-6 at right or left hand side of the actuator.

a) Screw the carrier bolt **16** into actuator coupling (see Fig. 12).

b) Screw mounting bracket **20** flush with the positioner with two M6 socket head cap screws (5 mm A/F).

c) Fasten positioner with mounting bracket **20** to the diaphragm actuator.

For diaphragm actuators with cast yokes:

Fasten mounting bracket **20** with screw M 8 to the threaded hole in the cast yoke.

This ensures that the feedback lever **9** is horizontal at 50 % stroke.

For diaphragm actuators with pillars:

Fasten mounting bracket **20** with two U-bolts **21** to the pillar in such a manner that feedback lever **9** which is loosely attached to shaft **17** of positioner and carrier bolt **16** is horizontal at 50 % stroke.

d) Set actuator to a 0 % stroke position.

Attach feedback lever **9** to shaft **17** of the positioner and carrier bolt **16** in such a manner that compensating spring **14** is above carrier bolt **16** when the mounting side is on the right, or below carrier bolt **16** when the mounting side is on the left.

Align and lock carrier bolt.

e) Press stroke factor lever **31** against stop screw **30** and create a frictional connection between feedback lever **9** and shaft **17** of positioner by tightening hexagon cap screw **15** (10 mm A/F) of feedback lever.

f) Connect positioner output y1 to single acting diaphragm actuators and connect outputs y1 and y2 to double acting diaphragm actuators.

g) Set up electrical connections.

h) Connect supply air of min. 1.4 bar to max. 6 bar, but no more than the maximum permissible operating pressure of the diaphragm actuator.

i) **Fasten housing cover in such a way that air vent of attached device faces downwards** (see Mark 'M' in Fig. 12).

Fig. 12: Actuator with pillars (mounting side left)

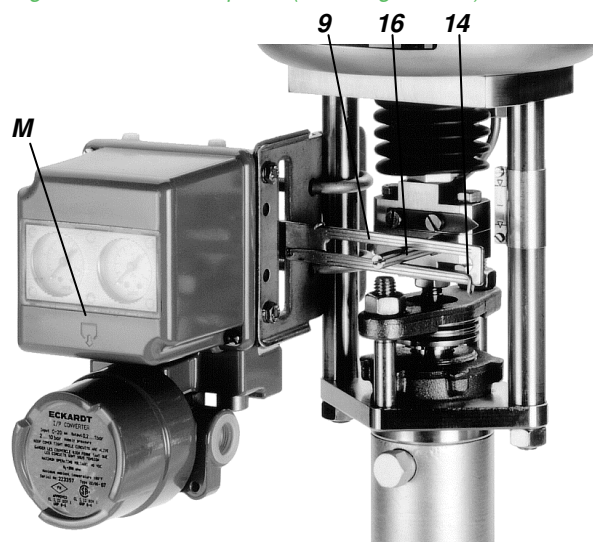

ATTACHMENT KIT FOR ROTARY ACTUATORS

With shaft
(according to VDI/DE 3845)
Code EBZG-ZN

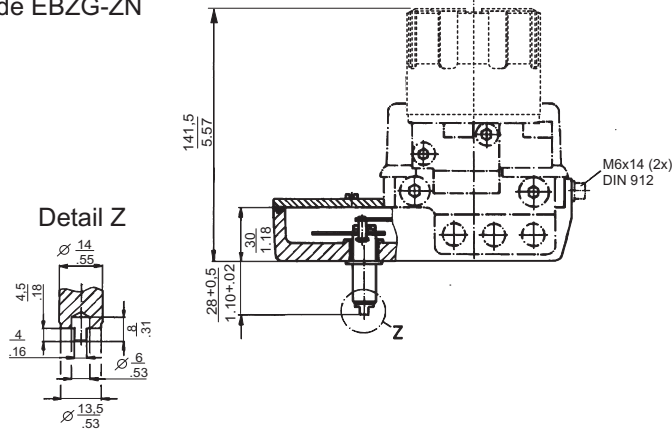

Housing dimensions
Attachment kit with shaft Code EBZG-ZN
resp. without flange Code EBZG-NN

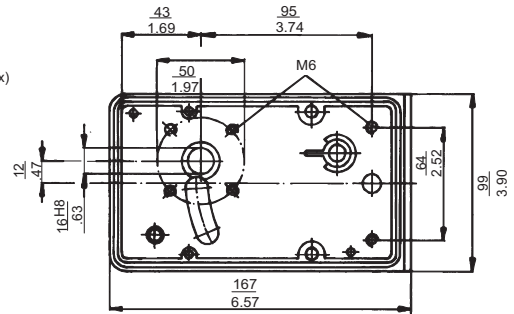

Without flange
Code EBZG-NN, -PN

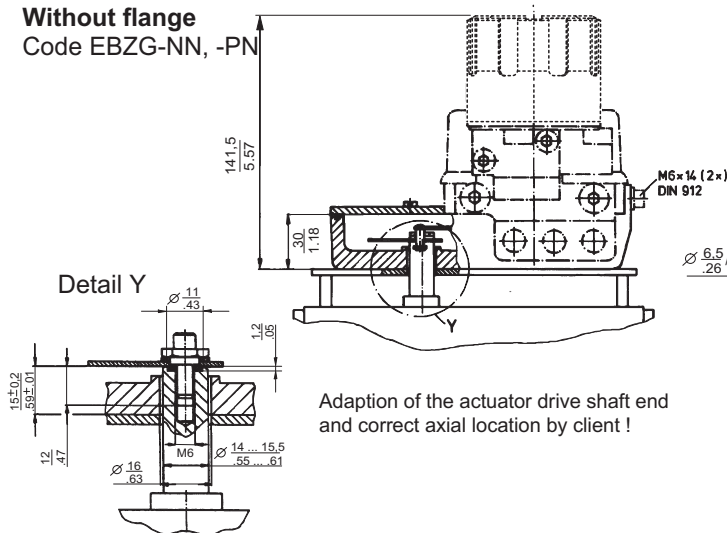

Housing dimensions
Attachment kit without flange
Code EBZG-PN

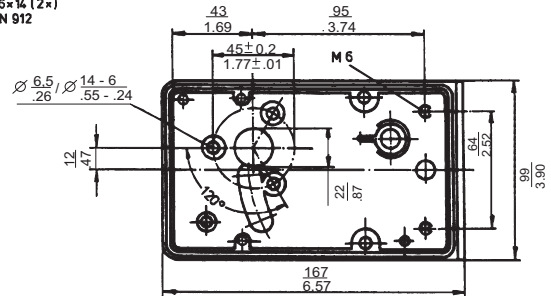

With flange
Code EBZG-JN

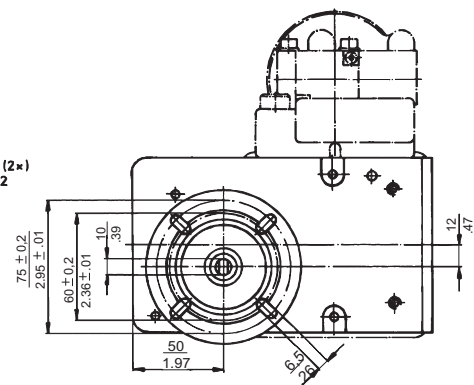
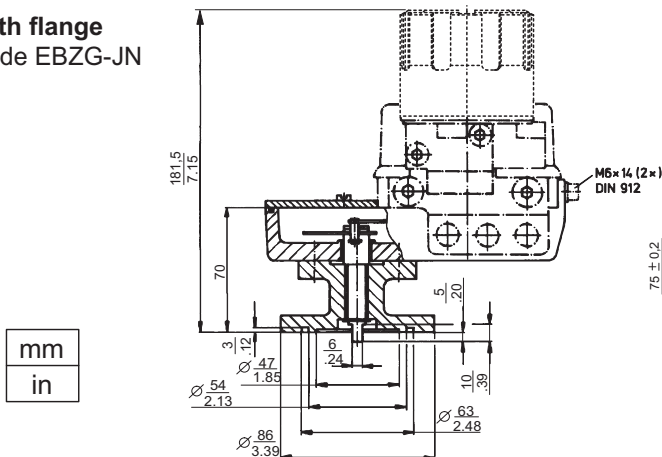

Rotation angle max 120°; torque requirement 14 Nm

2.3.2 Attachment to rotary actuators

For attachment of the positioner to rotary actuators or rotary armatures an attachment kit is required. The linear cam enables sensing of rotation angles up to 120 °, whereas the equal percentage and the inverse equal percentage cams sense rotation angles up to 90 ° (linear characteristic between 70 ° and 90 °).

Attachment

- a) Remove the transparent cover plate from the housing **26** of the attachment kit.
- b) Mount the housing of the attachment kit on rotary actuator or armature; use mounting hardware supplied by the actuator manufacturer if necessary.

Fig. 14: Rotary actuator with attachment kit



- c) Move actuator into the desired starting position (rotation angle = 0 °).
- d) Mount cam **24** in accordance with the direction of rotation of the actuator (see Fig. 15). The linear cam is fastened to the actuator drive shaft in such a manner that the dimension x or y (Fig. 16) amounts 2 mm, whereas in case of equal percentage cam the dimension x is approx. 17.5 mm, and the dimension y is approx. 21.5 mm. In case of inverse equal percentage cam the dimension x is approx. 18 mm, and the dimension y is approx. 23 mm. When employing equal percentage and the inverse equal percentage cams, the range spring 420 493 013 (included in spring set FESG-FN) must be installed in the positioner.

Fig. 15: Mounting position of the cams

A = Mounting position for actuator rotation ↙

B = Mounting position for actuator rotation ↘

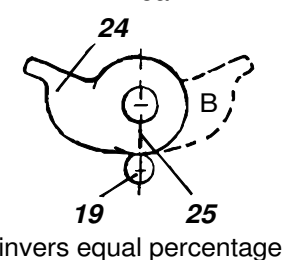
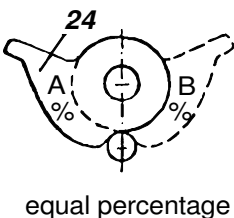
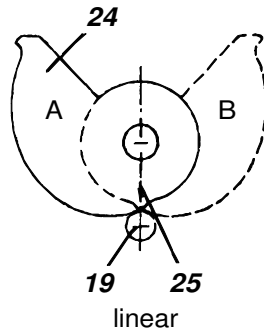

Fig. 16: Rotary actuator with attachment kit for rotary movement and double-acting positioner

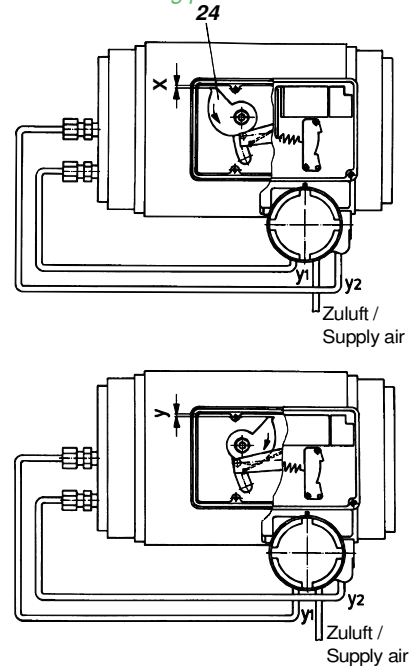
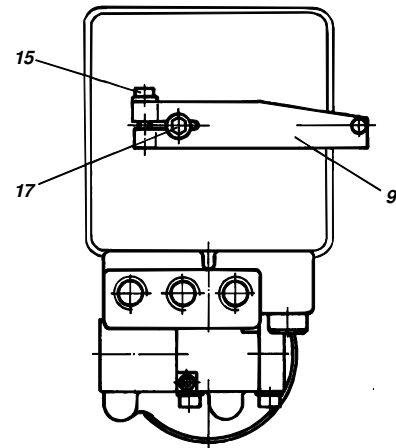
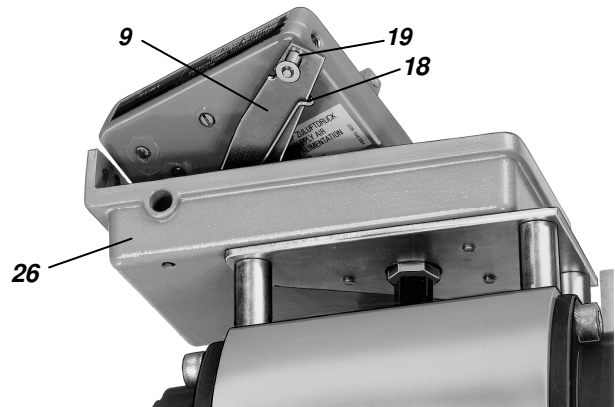

Fig. 17: Attaching feedback lever to the positioner



- e) Fasten feedback lever **9** for the rotary actuator onto shaft **17** of positioner as shown in Fig. 17.
- f) Mount positioner on housing **26** of attachment kit. Attach spring **18** to feedback lever **9** and cam follower **19** against cam (see Fig. 18).

Fig. 18: Alignment of cam



Screw positioner to housing of attachment kit. With the linear cam and the inverse equal percentage cam check whether mark **25** points to the center of the cam follower **19** (see Fig. 15); adjust if necessary.

With the equal percentage cam check whether the cam follower lies directly ahead of the start of the cam lobe; adjust if necessary.

- g) Final mounting of feedback lever **9** on shaft of positioner is performed at a stroke of 0 %, i.e. a rotation angle of 0°. First loosen 5 mm A/F Allen screw **15** of feedback lever **9** through hole **29** (see Fig. 19), then press stroke factor lever **31** against stop screw **30** (see page 23) and tighten Allen screw **15** firmly.
- h) With single acting actuators connect positioner output y1 to actuator; with double acting actuators connect y1 and y2 to actuator.
Connect chamber in which pressure is to build up with an increasing input signal to y1.
- i) Connect command variable w (input, 4-20 mA).
- k) Connect supply air of min. 1.4 bar to max. 6 bar, but do not exceed the maximum permissible operating pressure of the actuator.

Fig. 19: Tightening feedback lever

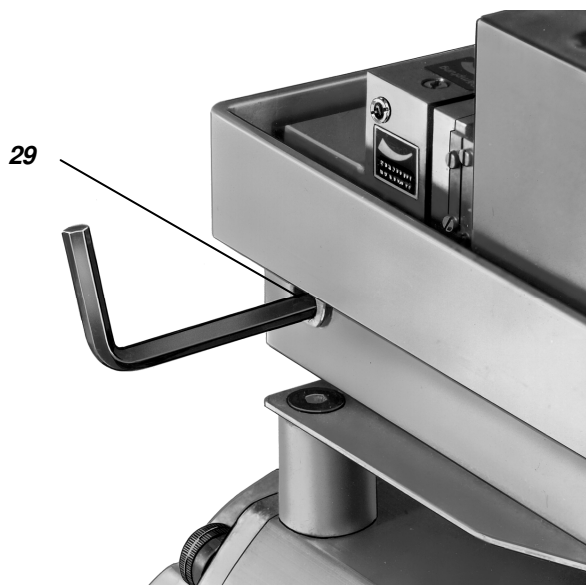

Note!

If actuator moves to an end position, the mounting position of cam does not coincide with the direction of rotation of the actuator. In this case install the cam **24** in the reverse position.

- l) Attach pointer **27** on the headed screw **28** in such a manner that 0° is indicated when the rotary actuator is in its starting position (w = 0).
- m) Attach the transparent cover plate.

2.3.3 Reversing direction of rotation

Single acting actuator:

Move changeover plate **50** (see page 23) to 'U' position and reverse cam **24**.

Double acting actuators:

Exchange positioner outputs (see Fig. 16) and reverse cam. The changeover plate **50** (see page 23) remains in 'N' position.

Fig. 20: Attachment kit for rotary movement and positioner

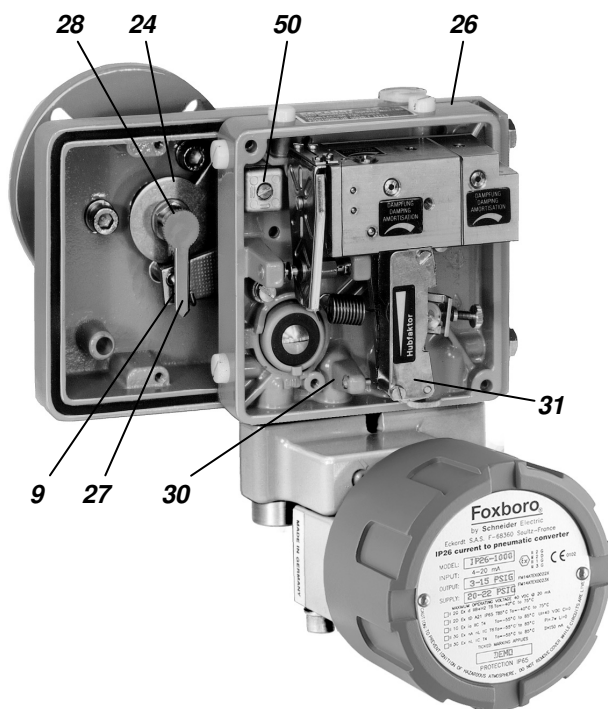

2.4 Manual bypass switch

The single acting pneumatic positioner can also be supplied with a bypass switch **51** (see page 23) if it is intended for use with actuators with a signal range of 0.2 to 1 bar. In the "ON" position the actuating signal of the master controller is supplied via the positioner; in the "OFF" position it is connected direct to the actuator.

Fig. 21: Bypass circuit

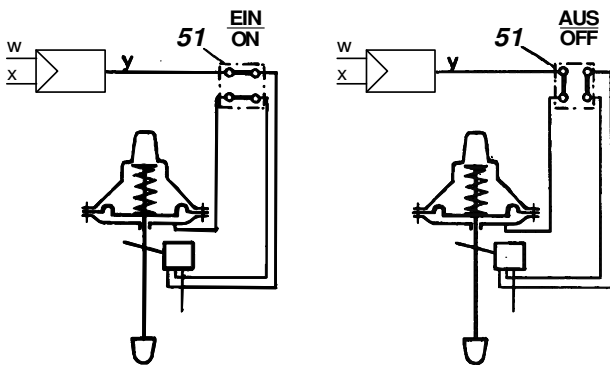

Note!

The bypass switch may only be operated in the normal direction of action (changeover plate **50** in position "N", see page 23), i. e. when the "OFF" position is set.

It should also be noted that the stored pressure in the actuator chamber may have a feedback effect on the preceding controllers when the "OFF" position is set, and could overload them.

The pressure in the actuator chamber should therefore be reduced accordingly before the changeover. The spring range of the actuator should not exceed the maximum signal value of the master controller, in order to ensure that the valve can open and close fully.

3 ELECTRICAL CONNECTIONS

During installation, the installation requirements by DIN VDE 0100 and/or DIN VDE 0800, as well as locally applicable requirements must be observed.

In addition, the requirements of VDE 0165 must be observed for systems associated with hazardous areas. Further important instructions are mentioned in page 22 (safety requirements, explosion protection).

If an earth connection or potential equalization is required, connect to earth connection **3**.

The units must be operated in a stationary position.

The line (cable) is guided through a screwed gland. This is suitable for line diameters of 6 to 12 mm.

The electrical connections for the command variable w is made at the + and – screw terminals **2**, which are suitable for wire cross-sections of up to 2.5 mm² (see Fig. 22).

Fig. 22: Electrical connections **2** and earth connection **3**

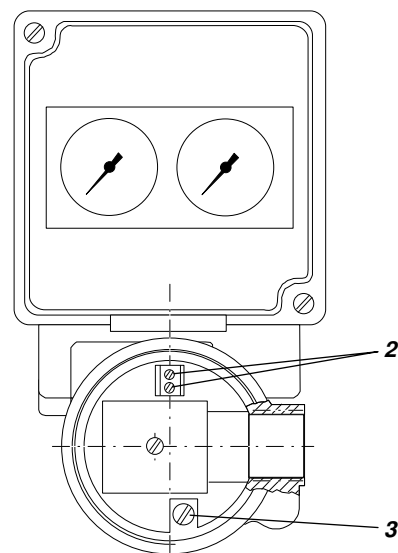

4 START-UP

Before commissioning electro-pneumatic positioners must be matched to the stroke and rotation angle of the actuator and to the input signal range.

The instruments can be connected to the 4 to 20 mA input signals or split ranges.

The supply air connected should be min. 1.4 bar and max. 6 bar, but should not exceed the maximum operating pressure of the diaphragm actuator.

4.1 Setting the gain

(see page 23)

The gain and thus the sensitivity of the positioner are set by means of the throttling screw **42**. The throttling screw is screwed in all the way in the factory, i.e. it is set to maximum gain. This gain varies with the supply air pressure, as shown in the following table:

Supply air	max. gain	
	Single-acting positioner	Double-acting positioner
1.4 bar	approx. 150	approx. 100
4 bar	approx. 90	approx. 150
6 bar	approx. 60	approx. 180

The linear gain is indicated. These values are based on the built-in range spring 420 494 019.

From this basic setting the gain can be matched to the dynamic requirements of the control system (counter-clockwise rotation of the throttling screw **42** results in less gain).

Note:

The zero point must be adjusted following each change of gain.

In order to ensure reliable pressure reduction in the actuator, the throttling screw **42** should not be opened beyond 1/4 turn at 6 bar. A limiting screw **43** is therefore incorporated.

The basic setting at the factory permits a maximum opening of the throttling screw **42** of approx. 1 turn.

4.2 Setting of zero point and stroke

(see page 23)

Before commencing settings press the flapper lever **35** several times alternately to the left and right in order to align the flappers correctly.

- Set the minimum value of the command variable w (start of stroke).
- Turn zero screw **32** until actuator just begins to move from its end position.
- Set maximum value of the command variable w (end of stroke).
- Turn the stroke factor screw **33** until actuator precisely reaches its end position:
Right turn: decrease of travel
Left turn: increase of travel

Recheck zero and stroke settings.

Note:

When stop screw **30** is correctly positioned and feedback lever is correctly mounted, there is no interaction between the adjustments of zero and stroke.

If the stroke cannot be adjusted with the installed spring, the correct spring can be approximately determined in accordance with the following criteria:

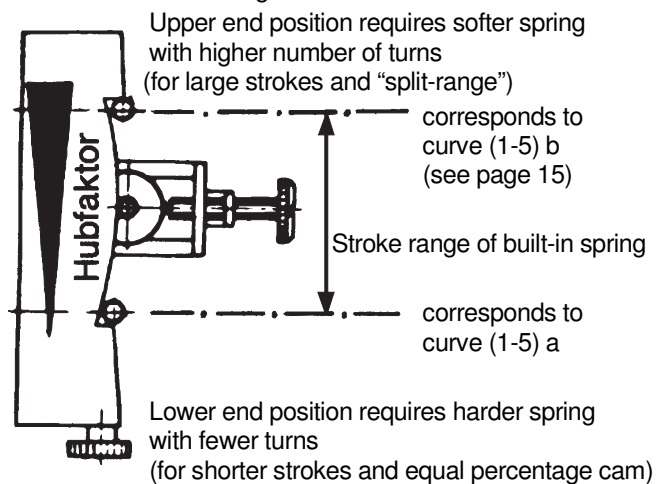

There are 5 differently rated springs available for matching the stroke and input signal range.

The particular spring **34** required can be determined precisely via stroke factor U_x .

4.3 Setting the damping

(see page 23)

The air output capacity of the positioner can be reduced by means of the damping throttle **44**.

Double-acting positioners are equipped with a damping throttle **44** for correcting the variable y_1 and a damping throttle **45** for correcting the variable y_2 .

In its normal setting the damping throttle is approximately flush with the amplifier housing.

The air output capacity is reduced by a factor of approx. 2.5 when the damping throttle is turned completely in.

A reduction of the air output capacity should only be done for very small actuator volumes since the control system would otherwise be too slow.

4.4 Subdivision of input range (split-range)

If several actuators are to be controlled by the same command variable and the complete stroke is to be executed in only one specific sub range of this command variable at a time, a positioner, the zero point and stroke range of which must be set to the desired sub-range of the command variable, must be provided for each actuator.

For actuation of several positioners by a master controller the positioners are connected in series.

Fig. 24: Example of 2-way sub division

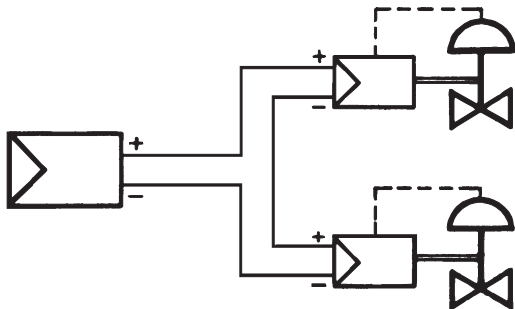

It should be noted that the permissible load of the controller may not be exceeded.

The input resistance of the positioner at 20 °C is approx. 200 Ohms.

Selection of the correct range spring can be made in accordance with the stroke factor range or the graph of the range springs (see page 15).

If the zero point has to be increased by more than 10 mA in case of multiple subdivision the adjustment must be made as follows: (see page 23)

- Shut off supply air.
- Remove tension from range spring **34** by turning zero screw **32**.
- Loosen hexagon cap screw (A/F 10) of feedback lever and turn stroke factor lever **31** away from stop screw **30**. This applies pretension to range spring **34**. In this position retighten hexagon cap screw of feedback lever.

Fig. 25: Pretension of the range spring

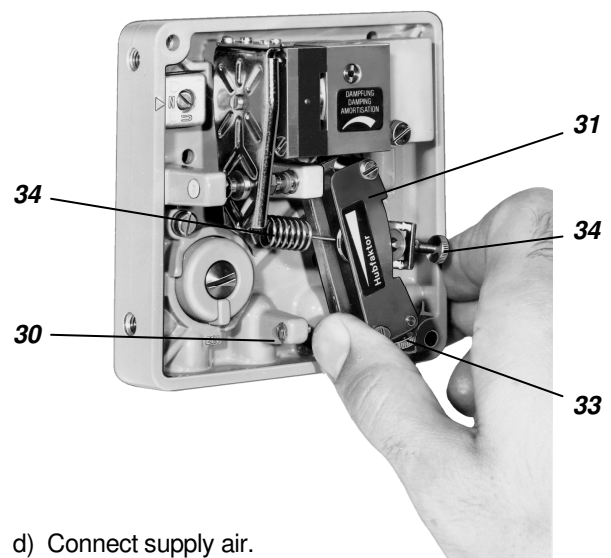

- Connect supply air.
- Set the minimum value of command variable w (start of stroke).
- Turn zero screw **32**, until the actuator begins to move from its end position. If this is not possible, the pretension of the range spring must be increased as described in c).
- Set maximum value of command variable w (end of stroke).
- Turn stroke factor screw **33** until the actuator precisely reaches its end position.

Note!

With this setting the zero point and stroke range are mutually dependent. Settings e) to h) must therefore be repeated as often as necessary until both settings are correct.

Furthermore it should be noted that the deflection of the stroke factor lever **31** from the starting position may not exceed a maximum of 39 °, since the stroke factor lever might otherwise touch the housing cover before reaching its end value.

4.5 Determination of rotation angle factor U_{ϕ}

In conjunction with the attachment kit for rotary actuators (Code EBZG-PN, -MN, -JN, -ZN, -RN) the rotation angle factor U_{ϕ} can be determined as follows:

$$U_{\phi} = \phi / \Delta w = \text{Rotation angle} / \text{Input signal range [mA]}$$

The rotation angle factors U_{ϕ} of the individual range springs are stated in the following table.

The rotation angles are also taken into account in the graph of the range springs (see page 15).

4.6 Determination of stroke factor U_x

The stroke factor U_x is the ratio of the entire range of the output variable (stroke x) to the entire range of the input variable (command variable w).

For diaphragm actuators PA-200 to PA700/702:

$$U_x = x / \Delta w = \text{Stroke in mm} / \text{Input signal range [mA]}$$

The stroke factor can be used to determine for each application whether or with which spring the desired setting can be made.

Five different range springs are available for matching to the stroke and input signal range.

4.6.1 Stroke factor ranges of the range springs

The stroke factor U_x determined as described above should lie within the ranges of the respective range springs indicated in the following table, as close as possible to the lower value.

	Range spring			Cam ¹⁾		Stroke factor ranges		Remarks
	Ident No.	old ID	Color	linear	Equal perc. and inverse equal perc.	Stroke factor U_x	Stroke Range ²⁾	
				max. 120°	max. 90°	mm / mA	mm	
1	420 493 013	FES 627/1	yellow	1.7 to 4.7 (max. 7)	2.4 to 8 (max. 10)	0.4 to 1.2 (max. 1.7)	8 to 34	²⁾
2	420 494 019	FES 628/1	green	3.5 to 9.5 (max. 14)	5 to 15 (max. 20)	0.85 to 2.3 (max. 3.35)	17 to 68	built-in
3	502 558 017	FES 612/1	- without -	5.8 to 14.5 (max. 21.75)	8.2 to 24 (max. 28)	1.4 to 3.5 (max. 5.25)	28 to 105	²⁾
4	420 496 011	FES 715/1	gray	8.4 to 21.5 (max. 32.75)	12 to 35 (max. 43)	2 to 5.5 (max. 7.9)	40 to 158 ³⁾	²⁾
5	420 495 014	FES 629/1	blue	11.5 to 27.5 (max. 41.5)	–	2.75 to 7 (max. 10)	55 to 200 ³⁾	²⁾

¹⁾ For equal percentage and inverse equal percentage cams the rotation angle factors are a function of their corresponding rotation angles

²⁾ Included in FESG-FN (Id No. 420 496 011)

4.6.2 Characteristics of the range springs

The stroke x_0 is based on the standard feedback lever $l_0=117.5$ mm.

Fig. 26: Feedback lever

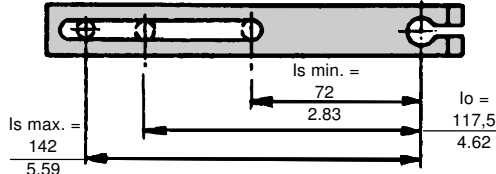

If another length (l_s) is used, the actual stroke x_s must be converted to stroke x_0 :

$$x_0 = 117.5 \cdot x_s / l_s \text{ [mm]}$$

Selection of measuring spring and setting of measuring span

Determination of suitable spring for split range:

- Enter desired set point value w for travel start in the diagram field.
- Determine x_0 if l_s unequal 117.5 mm.
- Enter intersection w/x_0 .
- Connect points determined at a) and c). This results in a straight line.
- If the straight line does not run through the origin, move this parallel here.
- Use the spring the characteristic line (a) of which is located directly below the presently determined characteristic line.

Example (shown in graph) Split range operation

Valve 1:

- $w = 0 \dots 10$ mA
- $x_s = 30$ mm (stroke range)
- $l_s = 140$ mm
- $x_0 = 117.5 \cdot 30 / 140 = 25.2$ mm

Intersection $w = 10$ mA with $x_0 = 25.2$ mm \rightarrow S1

Selected: Spring 4 (FES 715/1) because the characteristic curve based on the beginning of the determined straight line located directly below.

Valve 2:

- $w = 10 \dots 20$ mA
- $x_s = 50$ mm (stroke range)
- $l_s = 140$ mm
- $x_0 = 117.5 \cdot 50 / 140 = 42$ mm

Intersection $w = 20$ mA with $x_0 = 42$ mm \rightarrow S2

Selected: Spring 5 (FES 629/1) because the characteristic curve based on the beginning of the determined straight line located directly below.

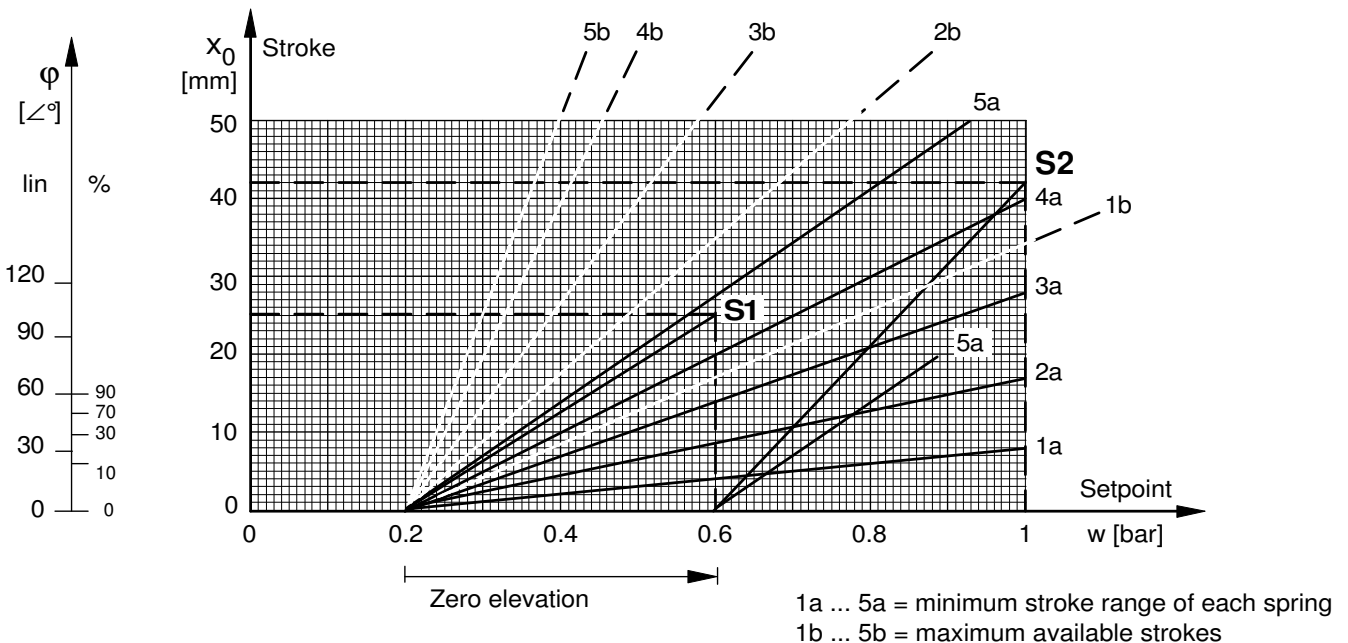

Lifting up of zero point for 4-20 mA and split range
1a, 2a, 3a, 4a, 5a = stroke starting of the respective spring
1b, 2b, 3b, 4b, 5b = max. stroke

- l_0 = Standard feedback effective length
- For feedback effective length $l_s = 117.5$ mm and $\Delta w = 20$ mA
- Theoretical value

5 MAINTENANCE

5.1 Basic Adjustment of Single-acting Positioner (pneumatic part)

Basic setting is only necessary after dismantling the device or changing modules.

All the settings for adapting the positioner to the actuator are described in page 12 (start-up).

The following tools are required for basic adjustment:

Screwdriver

1 open-end spanner 7 mm A/F

1 feeler 0.6 mm

1 test gauge 1.6 bar

1 DC signal generator

The feedback lever must be detached from the shaft of positioner if adjustment is done in the attached state.

For the following adjustments see page 23.

- a) Set changeover plate **50** to "N".
- b) Turn throttling screw **42** to the right as far as possible (maximum boost).
- c) Unhook range spring **34** from flapper lever **35**.
- d) Check whether the flappers **37** are concentric with the nozzles **36**. If not, align booster **40**. The fastening screws of the booster are accessible at the rear side of the positioner.
- e) Push flapper lever **35** alternately to the left and right several times to align the ball-guided flappers parallel to the nozzles.
- f) Push flapper lever **35** to the left. By turning the hexagonal rod **38** 7 mm A/F set the distance between the right-hand nozzle and the right-hand flapper to approx. 0.6 mm with the aid of a feeler. Then fasten the hexagonal rod tight.
- g) Connect the positioner as shown in the test circuit, fig. 28, and preset supply air to 1.4 bar.
- h) Press flapper lever **35** to the left. If the output *y* does not rise to supply air pressure, there are leaks or the flapper is not correctly positioned (repeat 'e').
- i) Hook range spring **34** into flapper lever and preset DC signal *w* = 10 mA. Proceed as follows to make zero setting independent of the stroke setting:
- k) Press stroke factor lever **31** against stop screw **30**.
- l) Set a large stroke factor (approx. 2 mm in front of top stop) with stroke factor screw **33**.
- m) Set zero screw **32** so that the output pressure *y* = approx. 0.6 bar and note this value.

- n) Set a small stroke factor (approx. 2 mm in front of bottom stop) with the stroke factor screw **33**. The output pressure *y* may not change by more than ± 150 mbar in relation to setting m).
- o) The stop screw **30** should be adjusted in case of greater deviations. Repeat settings l) to n) after every adjustment of the stop screw **30** until the deviation is less than ± 150 mbar.
- p) Secure stop screw **30** with varnish.

Put changeover plate **50** back in its original position. Re-install positioner or reattach the feedback lever to positioner shaft.

See page 12 for start-up.

Fig. 28: Test circuit for single acting positioner

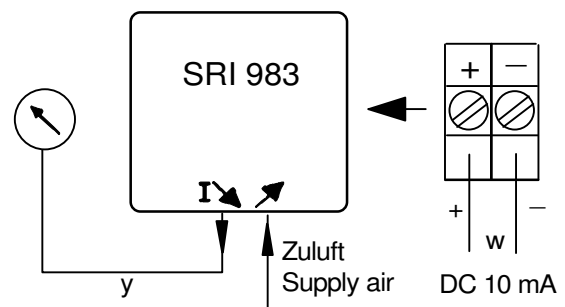

5.2 Basic Adjustment of the Double-acting Positioner (pneumatic part)

Basic setting is only necessary after dismantling the device or changing modules.

All settings for adapting the positioner to the actuator are described in page 12 (start-up).

The following tools are required for basic adjustment:

Screwdriver

1 open end spanner 7 mm A/F

1 feeler 0.6 mm

2 test gauges 6 bar

1 DC signal generator

The feedback lever must be detached from the shaft of the positioner if adjustment is done in the attached mode.

For the following adjustments see page 23.

- a) Leave changeover plate **50** set to "N".
- b) Turn throttling screw **42** to the right as far as possible (maximum boost).
- c) Unhook range spring **34** from flapper lever **35**.
- d) Check whether flappers **37** are concentric with nozzles **36**. If not, align booster **41**. The fastening screws of the booster are accessible at the rear side of the positioner.
- e) Push flapper lever **35** alternately to the left and right several times to align ball-guided flappers parallel to nozzles.
- f) Push flapper lever **35** to the left. By turning the hexagonal rod **38** 7 mm A/F set the distance between the right-hand nozzle and the right-hand flapper to approx. 0.6 mm with the aid of a feeler. Then fasten hexagonal rod tight.
- g) Connect positioner as shown in the test circuit, fig. 29, and preset supply air to 6 bar.
- h) Press flapper lever **35** to the right and left. The pressures y_1 and y_2 must change in opposition between 0 and supply air pressure.
- i) Hook range spring **34** into flapper lever and preset DC signal $w = 10$ mA.
- k) Set zero screw **32** so that pressures y_1 and y_2 are equal.
- l) Set adjustment screw **47** so that pressures y_1 and y_2 are set to approx. 4.2 bar (70 % of the supply air pressure). Repeat settings k) and l) alternately if necessary.
- m) Preset 1.4 bar supply air.
Set zero screw **32** so that pressures y_1 and y_2 are equal. They should be approx. 0.7 bar (50 % of the supply air pressure) (check measurement only).

Proceed as follows to make the zero setting independent of the stroke setting:

- n) Press stroke factor **31** lever against the stop screw **30**.
- o) Set a large stroke factor (approx. 2 mm in front of the top stop) with the stroke factor screw **33**.
- p) Set the zero screw **32** so that output pressures y_1 and y_2 are equal.
- r) Set a small stroke factor (approx. 2 mm in front of the bottom stop) with the stroke factor screw. The output pressures y_1 and y_2 may not change by more than ± 150 mbar in relation to setting p).
- s) The stop screw **30** should be adjusted in case of greater deviations. Repeat settings o) to r) after every adjustment of stop screw **30** until the deviation is less than ± 150 mbar.
- t) Secure stop screw **30** with varnish.

Reinstall the positioner or reattach the feedback lever to positioner shaft.

See page 12 for start-up.

Fig. 29: Test circuit for double acting positioner

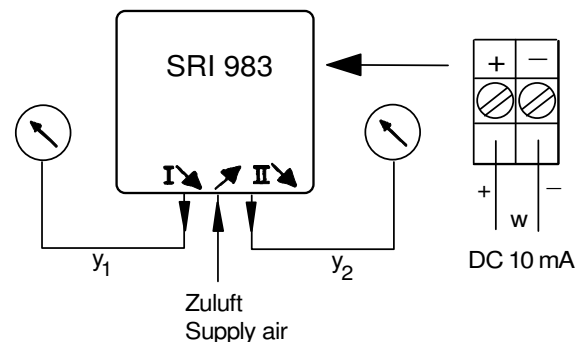

5.3 Cleaning the throttle

(see page 23)

- Remove the limiting screw **43**.
- Pull the throttling screw **42** down out of the limiting screw.
- Place the throttling screw **42** in a solvent (e. g. benzene) and blow through it carefully. It is still better to clean it in an ultrasonic bath.
- Turn the throttling screw **42** right in again as far as its stop (clockwise).
- Turn the limiting screw **43** right in as far as its stop (clockwise) and then back again counterclockwise by about half a turn.
- Secure the limiting screw **43** with sealing paint.

5.4 Check and adjust I-p converter

An adapter is required for checking and adjusting the I-p converter which can be done by you as shown in Fig. 32.

The following tools are required:

Screw driver,

5 mm A/F Allen keys,

1 test gauge 0 to 1.4 bar,

1 DC signal generator 4 to 20 mA,

Supply air 1.4 ± 0.1 bar.

- Remove the I-p converter **91** from connecting manifold **90** (two screws M 6), connect it to the adapter Fig. 32 and wire as shown in Fig. 30.
- Preset supply air 1.4 ± 0.1 bar.
- The test gauge must read 0.2 bar at current signal 0 mA. Otherwise set the adjustment screw **92** so that this value is indicated.
- Increase the current signal slowly from 4 to 20 mA. The test gauge reading must change proportionately to the current signal.

Current signal	Test gauge reading
0 mA	approx. 0.2 bar
20 mA	approx. 1 bar

- Adjust range with potentiometer **93**.

If these values are not achieved, there is a defect and the I-p converter should be replaced. Please contact the customer support for repair.

Fig. 30: Test circuit for I-p converter

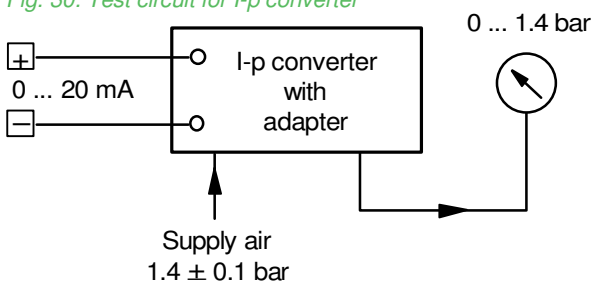

Fig. 31: I-p converter, cover removed

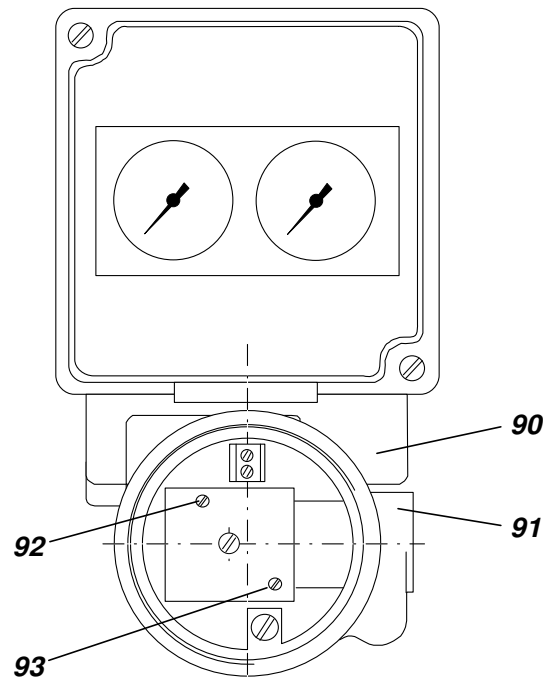
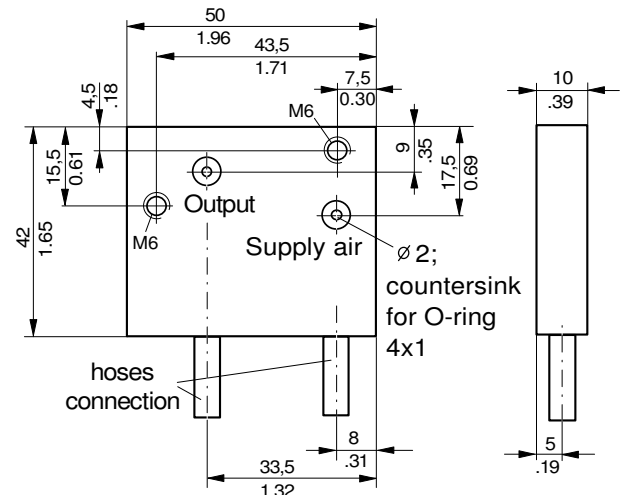

Fig. 32: Test adapter for I-p converter



6 TROUBLESHOOTING

Fault	Possible causes	Remedies
Actuator does not react to the applied input signal nor to a change in the input signal.	pneumatic connections switched	check connections
	electrical connections switched	reverse electrical connections
	feedback lever loose	tighten feedback lever
	Positioner mounted on the wrong side	check mounting side see table section 2.2.2
	changeover plate in the wrong position	check position see table in section 2.2.2
	booster defective	change booster (see 7.1)
	I-p converter defective	See note in section 5.4 and proceed accordingly
Output pressure does not reach full value	supply pressure too low	check supply air
	flappers not parallel to nozzles	align flappers (see 5.1 d, e or 5.2 d, e)
	pre-throttle in booster blocked	clean pre-throttle (see 5.3)
	I-p converter defective	see note in section 5.4 and proceed accordingly
	filter in supply connection blocked	change filter
Actuator runs to the end position	positioner mounted on wrong side	check mounting side see table section 2.2.2
	feedback lever loose	tighten feedback lever
	pneumatic connections switched (double-acting version)	check connections (see 2.2.2 or 2.3.2)
	boost too high	reduce boost (see 4.1)
Unstable behavior - positioner circuit oscillates	gland friction on valve too great	loosen gland slightly or renew
	for piston actuators: static friction on cylinder too great	reduce boost (see 4.1)
Stroke range cannot be set	range spring unsuitable	change range spring (see 4.5 and 4.6)
	positioner does not exhaust pressure completely	check supply air (max. 6 bar)
		check boost (see 4.1)
		adjust distance between nozzle and flapper (see 5.1 e, f or 5.2 e, f)

7 REPLACING SUBASSEMBLIES

7.1 Replacing the amplifier

(see page 23)

- a) Remove the housing cover.
- b) Unhook the range spring **34** from the flapper lever **35**.
- c) Unscrew and remove the amplifier **40** or dual amplifier **41**. The two mounting bolts are accessible from the rear of the positioner.
- d) Install a new amplifier.
Do not forget the O-rings between the amplifier and the base plate (manifold).
Before tightening the mounting bolts align the amplifier in such a way that the flappers **37** are concentrically aligned with the nozzles **36**.
- e) Hook the range spring **34** onto the flapper lever **35**.
- f) Perform a basic adjustment (see 5.1 or 5.2).

7.2 Replacing the amplifier diaphragm in the single acting positioner

- a) Remove the amplifier **40** (see 7.1)
- b) Dismantle the amplifier.
Remove the screw **54**.
Remove the two screws **56**.
Remove the strip **55** and flapper lever **35**.

Fig. 33: Amplifier

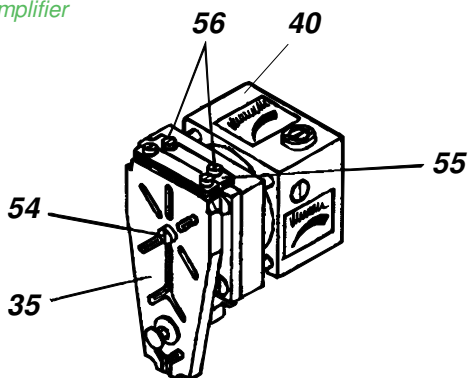

When the four screws **63** are removed, the amplifier can be dismantled into the following components:

- 64** Housing block A
- 65** Pipe
- 66** Spring
- 67** Diaphragm disk subassembly
- 68** Amplifier diaphragm
- 69** Housing block B
- 70** Input diaphragm subassembly
- 71** Cover

- c) Reassembly of amplifier:
Reassemble the components and subassemblies in the correct position in the sequence specified. Replace faulty parts.

Put housing block A **64** with the open side facing upwards. Insert pipe **65** in the hole in the housing block A. Place spring **66** in position in the diaphragm disk subassembly **67**. Insert diaphragm disk subassembly **67** in housing block **64** so that the pipe **65** passes through the holes in the diaphragm disk subassembly **67**. Place amplifier diaphragm **68** on the diaphragm disk subassembly **67** (with the projection facing downwards), pipe **65** should be inserted in the hole of the amplifier diaphragm **68**.

Place housing block B **69** in its correct position, so that the pipe **65** is inserted in the relevant hole in housing block B **69**. Press housing block B **69** against housing block A **64**.

Note:

When these two components are pressed together housing block B **69** should be plane-parallel with housing block A **64**.

If not, check why they are misaligned. Is pipe **65** in its correct position in the holes of housing block A **64** and housing block B **69**?

Insert input diaphragm subassembly **70** in housing block B **69**. Install cover **71** in the right way round (threaded holes on the amplifier setting side), and screw the amplifier together. Tighten the four screws **63** uniformly.

- d) Screw on the flapper lever **35** again.
- e) Install the amplifier (see 7.1)
- f) Perform a basic adjustment (see 5.1)

Fig. 34: Amplifier dismantled

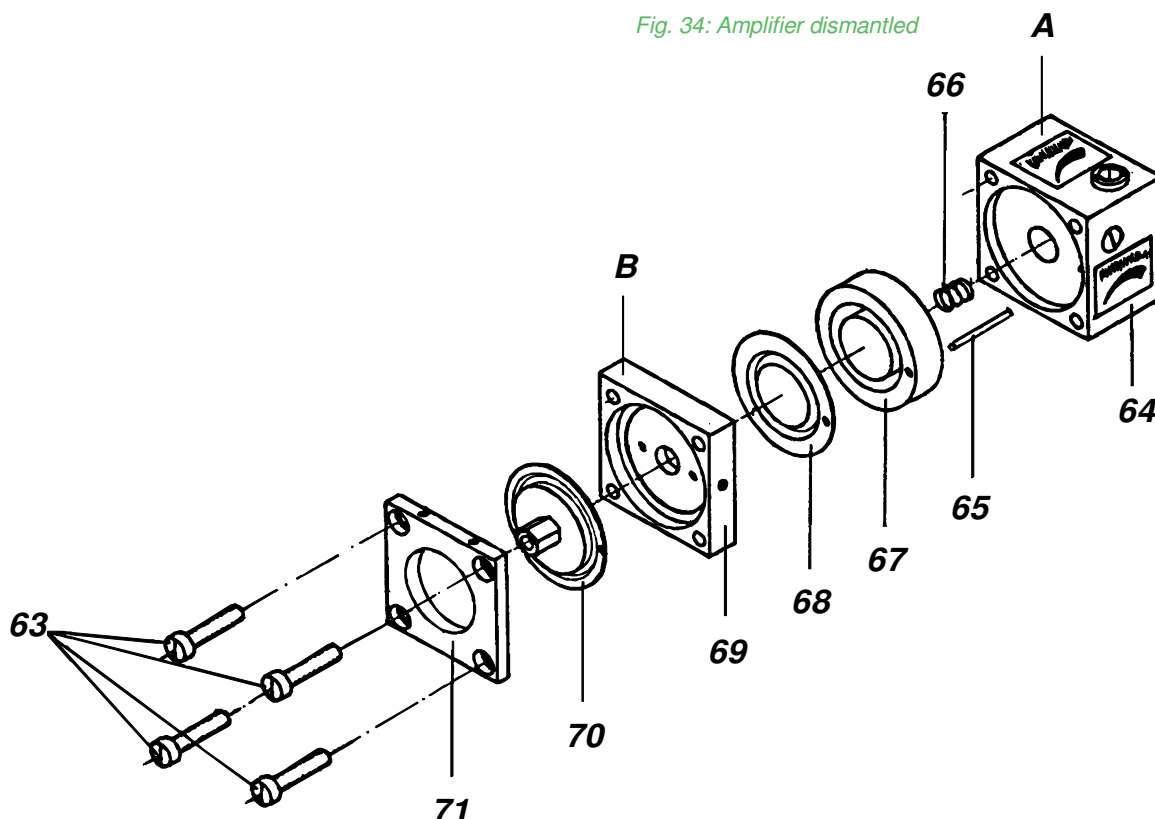

7.3 Replacing the amplifier diaphragm in the double acting positioner

Remove the dual amplifier **41** (see 7.1)

Replace the input diaphragm

- Remove screw **54**.
- Remove two screws **56**, the strip **55** and the flapper lever **35**.

Fig. 35: Dual amplifier

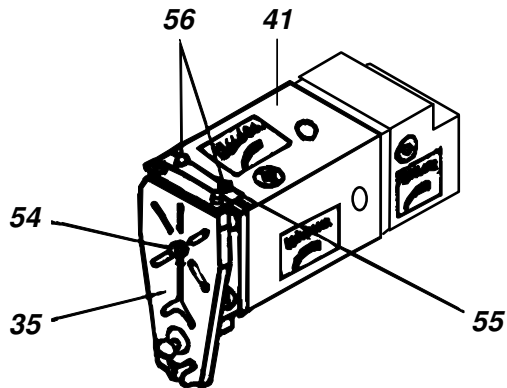

- Remove four screws **72** and the cover **71**.
- Remove and replace the input diaphragm subassembly **70**.
- Reassemble the input diaphragm in the reverse order.

Replace the diaphragm assembly

- Remove four screws **73** and housing block A **74**.
- Remove spring washer **75**.
- Through the holes **76**, the diaphragm assembly **77** can be pressed out of the housing block B **78**, for example by means of a small screwdriver. The diaphragm assembly is a self-contained component and should not be dismantled further.

- Insert the new diaphragm assembly **77** in its correct position in housing block B **78**.

Important note:

The pipe **79** passes through the first disk **80** and is inserted in a hole in the second disk **81**.

If the two disks **80** and **81** are not absolutely flush when the diaphragm assembly is pressed together by hand, the pipe is not in its correct position in the hole. In this case disk **81** should be turned until the pipe is correctly inserted in the hole.

- Install housing block A **74** in its correct position and screw on with the four screws **73**.
- Measure the gap between the housing blocks **74** and **78** with the aid of a feeler gauge.
- The spring washer **75** selected should have a wire diameter which corresponds to the gap measured as described in f), or which is no more than 0.1 mm smaller in diameter.
- Remove the four screws **73** again and remove housing block A **74**.
Install the spring washer **75** selected, replace housing block A **74** in its correct position, and tighten the screws **73** firmly and uniformly. Align the spring washer so that it does not project over the edges of the housing blocks **74** and **78**.

Reinstall the amplifier (see 7.1) and perform basic adjustment (see 5.2).

Fig. 36: Dual amplifier dismantled

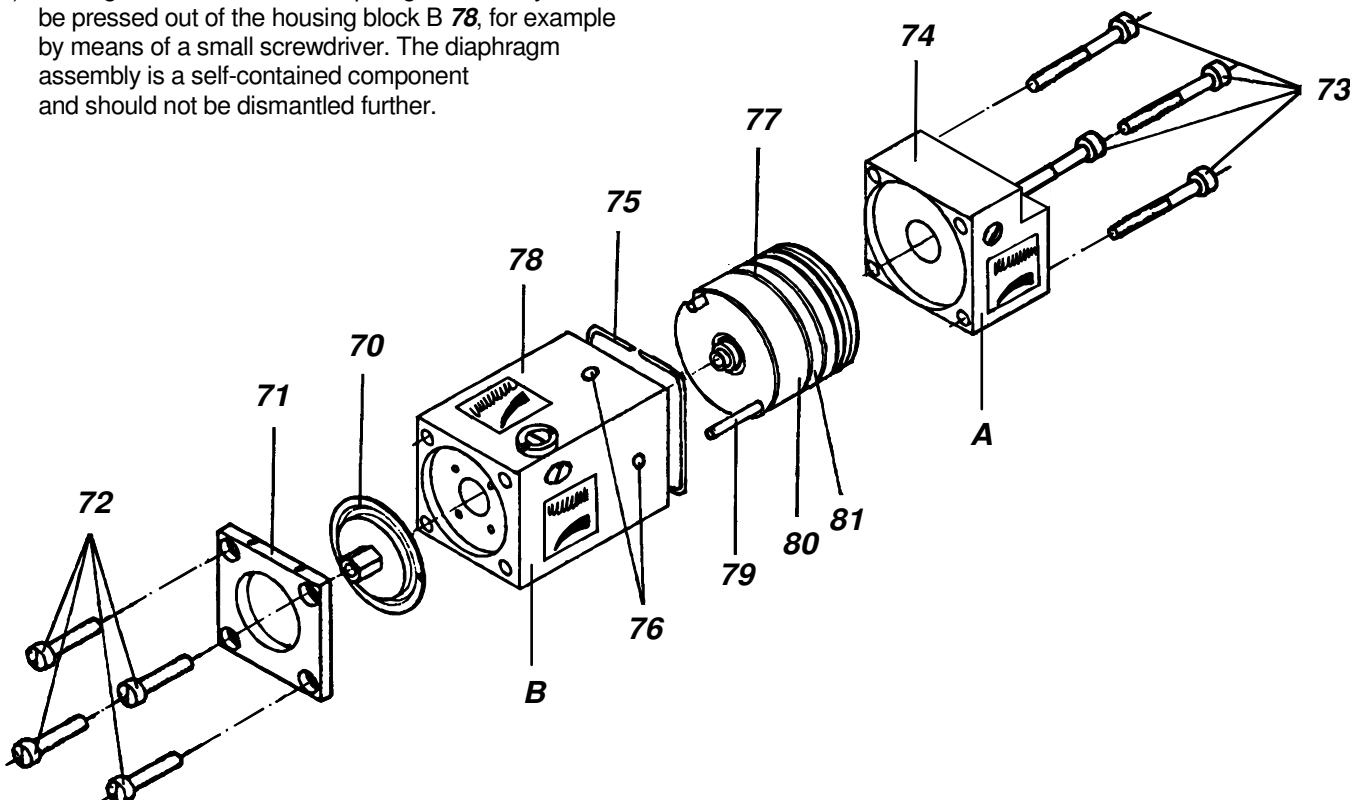

8 SAFETY REQUIREMENTS

8.1 Accident prevention

This device complies with the regulations for the prevention of accidents Power-Driven Work Aids (VBG 5) of October 1st, 1985.

8.2 Electrical safety

8.2.1 General requirements

When the housing is open, repair and maintenance operations must always be carried out by service personnel if any power sources are connected to the device.

8.2.2 Regulations for Connection

The device is to be used according to its purpose and is to be connected in compliance with its connection plan (see section 3). The locally effective national directives for electrical installations are to be observed, e.g. in the Federal Republic of Germany DIN VDE 0100 resp. DIN VDE 0800.

The units may only be operated with safety extra-low voltage SELV or SELV-E.

The protective measures provided in the units can become ineffective if the unit is not used in accordance with the operation instructions.

The limitation of the circuit for fireproofing is to be customer guarded according to EN 61010-1, Appendix F (IEC 61010-1 resp.).

8.2.3 Explosion protection

For technical data concerning explosion protection please refer to product specification PSS EVE0103A.

Please observe the effective national rules and installation instructions concerning installations in hazardous locations, for instance in the Federal Republic of Germany these are ExeV and DIN VDE 0165.

Attention!

Observe the corresponding national requirements for repairing explosion-protected devices.

Use only original spare parts when making repairs.

The following applies to the Federal Republic of Germany: Repairs on parts on which the explosion protection depends must either be done by the manufacturer or must be checked by an authorized expert and approved by his test mark or a certificate.

8.2.4 EMC and CE

For references pertaining to electro-magnetic compatibility EMC and regarding CE certification see product specifications PSS EVE0103 A.

Detail: Nozzles/ flappers system

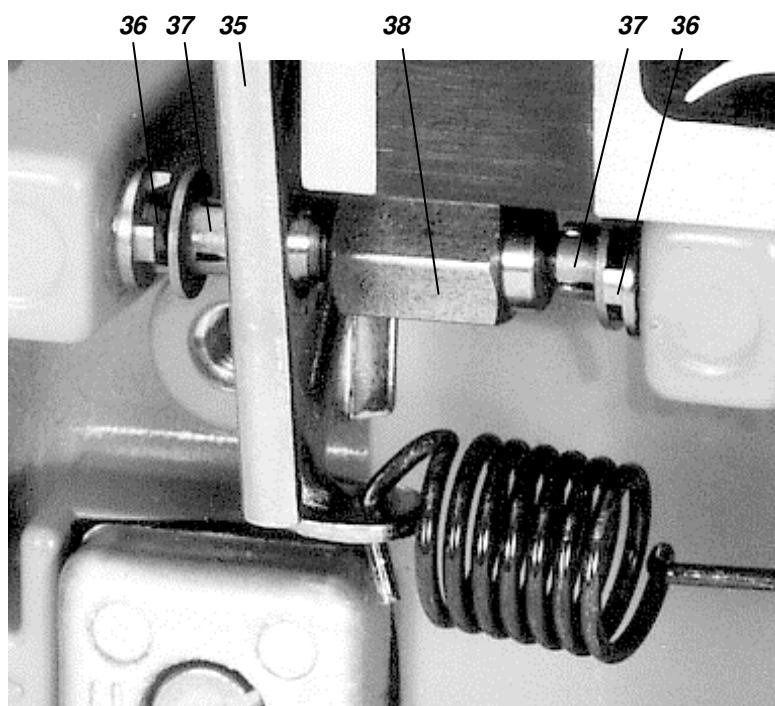

Single acting Positioner SRI983

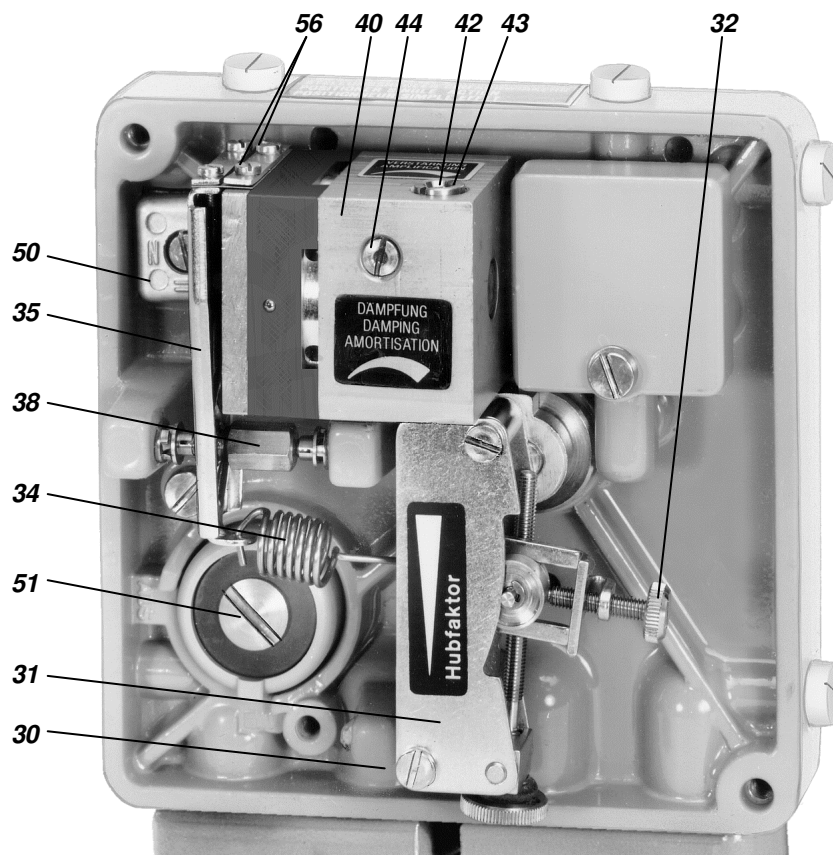

Double acting Positioner SRI983

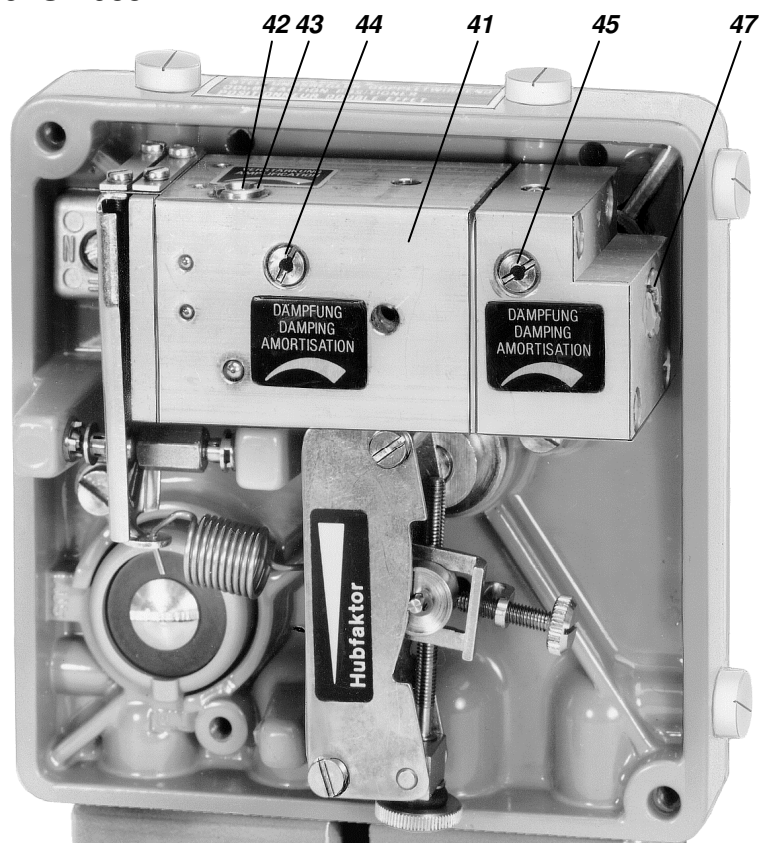

Schneider Electric Systems USA, Inc.
38 Neponset Avenue
Foxboro, MA 02035
United States of America
<http://www.schneider-electric.com>

Global Customer Support
Inside U.S.: 1-866-746-6477
Outside U.S.: 1-508-549-2424
<https://pasupport.schneider-electric.com>

Copyright 2010-2019 Schneider Electric
Systems USA, Inc. All rights reserved.

Schneider Electric is a trademark of
Schneider Electric Systems USA, Inc., its
subsidiaries, and affiliates. All other trademarks
are the property of their respective owners.

