

**SRD991 Intelligent Positioner with HART, PROFIBUS-PA,  
FOUNDATION Fieldbus H1 or Without Communication**



The intelligent positioner SRD991 is designed to operate pneumatic valve actuators and can be operated from control systems (e.g. the Foxboro I/A Series System), controllers or PC-based configuration- and operational tools such as FDT/DTM Software. The positioner is available with different communication protocols. The multi lingual full text graphical LCD in connection with the 3 push buttons allows a comfortable and easy local configuration and operation. For installations in contact with explosive atmospheres, certificates are available.

**DEVICE FEATURES**

**Intelligent**

- Auto-start with self-calibration
- Self diagnostics, status- and diagnostic messages
- Easy operation with three key pads
- Multi-Lingual full text graphical LCD
- VALcare™ or Valve Monitor DTM for valve diagnostics and predictive maintenance

**With communication**

- HART, FOUNDATION Fieldbus H1, PROFIBUS-PA
- Configuration by means of local keys, hand-held terminal (HART), PC with FDT-DTM or I/A Series system

**Without communication**

- Input signal 4 to 20 mA

**COMMON FEATURES**

- Stroke 8 to 260 mm (0.3 to 10.2 in) with standard lever; larger stroke with special lever
- Angle range up to 95° (up to 300° as option)
- Supply air pressure up to 6 bar (90 psig), with spool valve up to 7 bar (105 psig)
- Single or double-acting
- Mounting on linear actuators according to NAMUR – IEC 50534-6-1 – VDI/VDE 3847
- Mounting on rotary actuators acc. to VDI/VDE 3845 or IEC60534-6-2
- Protection class IP 66 and NEMA 4X
- Approved for SIL applications
- Explosion protection: Intrinsic safety according to ATEX / IECEx, FM, CSA, INMETRO, NEPSI, EAC, and more

*Equipment should be installed, operated, serviced, and maintained only by qualified personnel.  
No responsibility is assumed by Schneider Electric for any consequences arising from the use of this material.*

**LABELS**

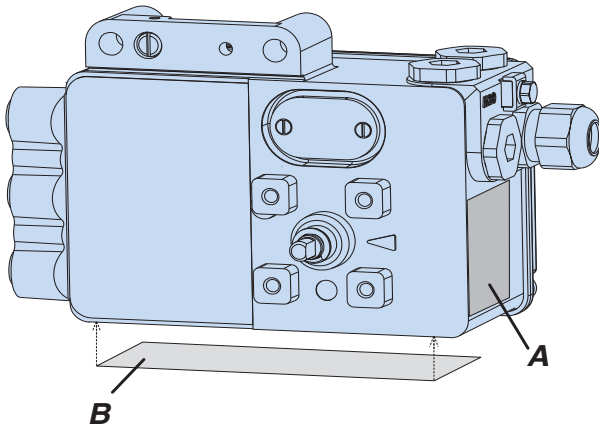

- A** Nameplate
- B** Nameplate
- C** Warning labels, terminal wiring, key and LED-designation
- D** Brief description inside cover

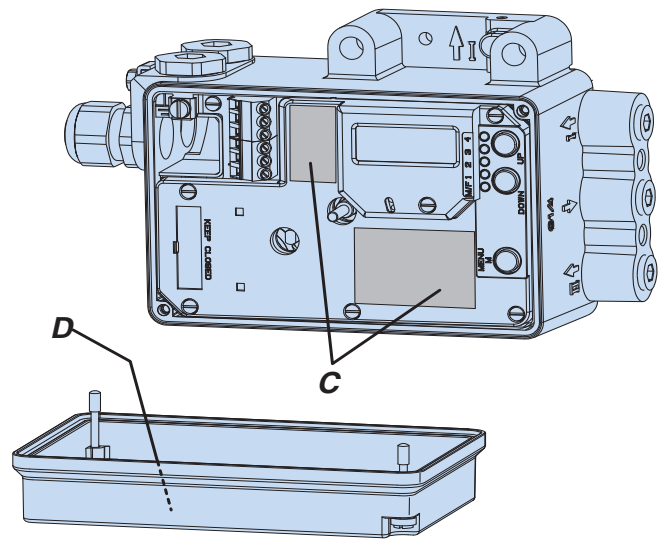

**Nameplate B** (Example)  
Without Ex protection, with options

<b>ECKARDT</b> <b>invensys</b>		REV. <input type="checkbox"/>
SRD		ZUSÄTZLICHE EIN- / AUSGÄNGE ADDITIONAL INPUTS / OUTPUTS
ZULUFT / SUPPLY : max. / bar / psi		STELL.RÜCKMELDUNG POSITION RETURN
<input type="checkbox"/> EINFACH / SINGLE	<input type="checkbox"/> DOPPELT / DOUBLE	GRENZWERTGEBER (INDUKTIVE KONTAKTE)
EINGANG / INPUT		LIMIT SWITCH (INDUCTIVE CONTACTS)
<input type="checkbox"/> 4...20 mA	<input type="checkbox"/> HART	SICHERHEITS- AUSFÜHRUNG SECURITY-VERSION
<input type="checkbox"/> PROFIBUS PA	<input type="checkbox"/> FF-Fieldbus H1	GW1   LS1
	Tu -40°...+80°	GW2   LS2
Made in France by Eckardt SAS, F-68360 Soultz		31 32   81 82
		41 42   51 52
		(1)

SRD [ Device specification, Model Code ]  
SER.No [ Serial number ]  
ECEP [ Number for special engineered version ]

**Nameplate B** (Example)  
With Ex protection acc. to ATEX, T4 / T6, with options

<b>ECKARDT</b> <b>invensys</b>		REV. <input type="checkbox"/>
SRD		ZUSÄTZLICHE EIN- / AUSGÄNGE ADDITIONAL INPUTS / OUTPUTS
ZULUFT / SUPPLY : max. / bar / psi		TYP AI 638 (OP) REV.2.0 TYP AI 638 (LT) REV.2.0
<input type="checkbox"/> EINFACH / SINGLE	<input type="checkbox"/> DOPPELT / DOUBLE	BINÄRAUSGÄNGE BINARY OUTPUTS
EINGANG / INPUT		GRENZWERTGEBER (INDUKTIVE KONTAKTE)
<input type="checkbox"/> 4...20 mA (GI)	<input type="checkbox"/> HART (GH)	LIMIT SWITCH (INDUCTIVE CONTACTS)
<input type="checkbox"/> PROFIBUS PA	<input type="checkbox"/> FOXCOM IT2 (GF)	SICHERHEITS- AUSFÜHRUNG SECURITY-VERSION
<input type="checkbox"/> acc.FISCO (GP)	<input type="checkbox"/> FF-Fieldbus H1	GW1   LS1
<input type="checkbox"/> acc.FISCO (GQ)	<input type="checkbox"/> acc.FISCO (GQ)	GW2   LS2
PTB 00 ATEX 2128 TYPE AI 638 GP REV.2.0		1   81 82
II 2 G EEx ia/lb IIB / IIC T6 / T4		2   83 84
U <sub>i</sub> I <sub>i</sub> P <sub>i</sub> C <sub>i</sub> L <sub>i</sub> Tu min. Tu max.		U <sub>i</sub> I <sub>i</sub> P <sub>i</sub> L <sub>i</sub> C <sub>i</sub>
siehe Betriebsanleitung/see Instruction Manual		siehe Betriebsanleitung see Instruction Manual
Made in France by Eckardt SAS, F-68360 Soultz		(1)

**Nameplate A** (Example)  
acc. to FM, with options

<b>ECKARDT</b> <b>invensys</b>	
SER.No	
SUPPLY MAX.: psi bar	<input type="checkbox"/> SINGLE <input type="checkbox"/> DOUBLE
<input type="checkbox"/> 4...20mA	<input type="checkbox"/> HART <input type="checkbox"/> FOXCOM IT2 <input type="checkbox"/> PROFIBUS PA* <input type="checkbox"/> FF-FIELDBUS H1*(acc. FISCO)
I.S. CL I, Div 1, Gp ABCD; CL II, Div 1, Gp EFG; CL III, Div 1; T6/T4 See 534 396 049 ( ) CL I, Div 2, Gp ABCD; CL II, Div 2, Gp FG; CL III, Div 2.	
Max Amb: T6 at +55°C / 131°F; T4 at +80°C/176°F; Ta min -40°C/-40°F	
WARNING: Substitution of components may impair intrinsic safety and the suitability for Class I, Division 2 Do not disconnect equipment unless power has been switched off or the area is known to be non-hazardous.	
REV.	
Made in France by Eckardt SAS, F-68360 Soultz	

ZUSÄTZLICHE EIN- / AUSGÄNGE ADDITIONAL INPUTS / OUTPUTS ENTREES / SORTIES ADDITIONELLES	
ModelCode: x x P x x x	ModelCode: x x x U x x
BINÄRAUSGÄNGE BINARY OUTPUTS SORTIES BINAIRES	GRENZWERTGEBER (INDUKTIVE KONTAKTE) LIMIT SWITCH (INDUCTIVE CONTACTS)
CHANNEL CANAL	VALEURS LIMITES (CAPTEURS INDUCTIFS)
1   81 82	SICHERHEITS- AUSFÜHRUNG SECURITY-VERSION VERSION SECURITE
2   83 84	LS1   LS2
	VL1   VL2
	41 42   51 52
556729108 (2)	

**Measurement point label** (Example)  
Directly fixed or attached

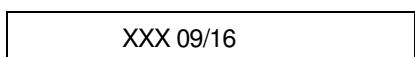

**Additional manufacturing data** are stored in the software and are read via communication interface.

**TABLE OF CONTENTS**

CHAP: CONTENT	PAGE	CHAP: CONTENT	PAGE	
<b>LABELS</b> .....	<b>2</b>	<b>8</b>	<b>START-UP</b> .....	<b>23</b>
<b>0</b>	<b>SUMMARY</b>	General .....	23	
	HART Communication and 4-20 mA.....	8.1	Setting by means of local keys.....	23
	FOUNDATION Fieldbus Communication	8.2	Operating modes (LCD / LED) .....	24
	PROFIBUS PA Communication.....		Operation with local keys .....	25
			Table: Menu structure .....	26
<b>1</b>	<b>METHOD OF OPERATION</b> .....	8.3	Configuration of 0 % and 100% .....	28
1.1	General.....	8.4	Description of menus.....	30
1.2	Block diagram .....	8.5	Setting of the travel indicator.....	45
1.3	Operation .....			
<b>2</b>	<b>OPERATING MODES</b> .....	<b>9</b>	<b>DECOMMISSIONING</b> .....	<b>45</b>
<b>3</b>	<b>FUNCTIONAL DESIGNATIONS</b> .....	<b>10</b>	<b>MAINTENANCE</b> .....	<b>46</b>
3.1	Pneumatic accessories .....	10.1	Service Connector and IrCom.....	46
<b>4</b>	<b>MOUNTING TO ACTUATORS</b> .....	10.2	Supply filter replacement.....	46
4.1	Linear, NAMUR Mounting (left hand).....	10.3	Removal of the electronics unit .....	46
4.2	Linear, NAMUR Mounting (right hand)...			
4.3	Linear, Direct Mounting .....	<b>11</b>	<b>TROUBLE-SHOOTING GUIDE</b> .....	<b>47</b>
4.4	Rotary actuators.....	<b>12</b>	<b>SAFETY REQUIREMENTS</b> . . . . .	<b>52</b>
<b>5</b>	<b>PNEUMATIC CONNECTIONS</b> .....	<b>13</b>	<b>SYSTEM CONFIGURATION</b> .....	<b>52</b>
<b>6</b>	<b>ELECTRICAL CONNECTION</b> .....	<b>14</b>	<b>DIMENSIONS</b> .....	<b>54</b>
<b>7</b>	<b>OPTIONS</b> .....			
7.1	“Limit switch” .....			
7.2	“Additional In-/Outputs” .....			
7.3	“Built-in pressure sensors” .....			

**Installation and start-up of instrument to be carried out only by qualified personnel, familiar with installation and start-up procedures and operation of this product!**

**Accident prevention**

The connected instrument contains mechanically moved parts, e.g. feedback lever, which could cause injuries. The operators have to be instructed accordingly.

**Electrical safety**

This instrument satisfies the conditions for safety class III, overvoltage category I according to EN 61010-1 or IEC1010-1.

Any work on electrical parts must be done by qualified personnel if any supply is connected to the instrument. The instrument must be used for its designated purpose and connected in accordance with its connection diagram (see page 20).

Locally applicable installation regulations for electrical equipment must be observed, e.g. in the Federal Republic of Germany DIN VDE 0100 resp. DIN VDE 0800.

The instrument must be operated with safety extra low voltage SELV or SELV-E.

Safety precautions taken in the instrument may be rendered ineffectual if the instrument is not operated in accordance with the Master Instructions.

Limitation of power supplies for fire protection must be observed due to EN 61010-1, appendix F or IEC 1010-1.

## Summary – HART and 4-20 mA without Communication

Start-up according to following steps:

### Mounting to Actuator (Valve)

The SRD991 can be mounted to linear or rotary actuators. More see page 11.

### Connection and Start-up

Upon connection of supply air and a current source of e.g. DC 12 mA to the input terminals (pay attention to polarity, see page 20) an initial start-up can be carried out without any further equipment.

With the local push buttons, basic parameters can be changed, such as type of actuator, side of installation, valve opens/closes with increasing set point value, and characteristics curve of the valve (values set ex-factory: stroke actuator, installation left, valve opens with increasing set-point value, linear characteristics curve).

Thereafter an AUTOSTART can be performed; during which the SRD991 determines independently the geometric data of the actuator as well as control parameters, to ensure an optimized operation with the attached valve. More see page 23.

HART version:

The positioner can be operated either locally or via hand-held terminal or PC (via modem). More see page 52.

### System configuration

**Version 4-20 mA without communication:** Connection as traditional point-to-point connection according to the known regulations of the measuring & control techniques.

**HART version:** When using 'Communication' (an a.c. signal which modulates on the 4-20 mA signal), it must be ensured that the connected outputs, buffer amplifier and barriers are compatible with the frequency ranges used. In addition to the load, the AC impedance requirements must be met. Therefore, it is recommended that only the specified amplifier, barrier and configuration device be used. More see page 52.

To prevent crosstalk between lines and reduce disturbances through electromagnetic influences, it is recommended that twisted-pair shielded lines be used, with a diameter of AWG 22 - 14 (0.3 to 2.5 mm<sup>2</sup>) and a max. capacity of 100 pF/m.

The line capacities and connected devices may not exceed the maximum values listed for a particular HART protocol.

All components which are connected to the SRD in an explosion hazardous area, require an Ex Approval. The applicable limit values must not be exceeded. These limit values also have to be adhered to when connecting additional capacitances, inductances, voltage or current sources.

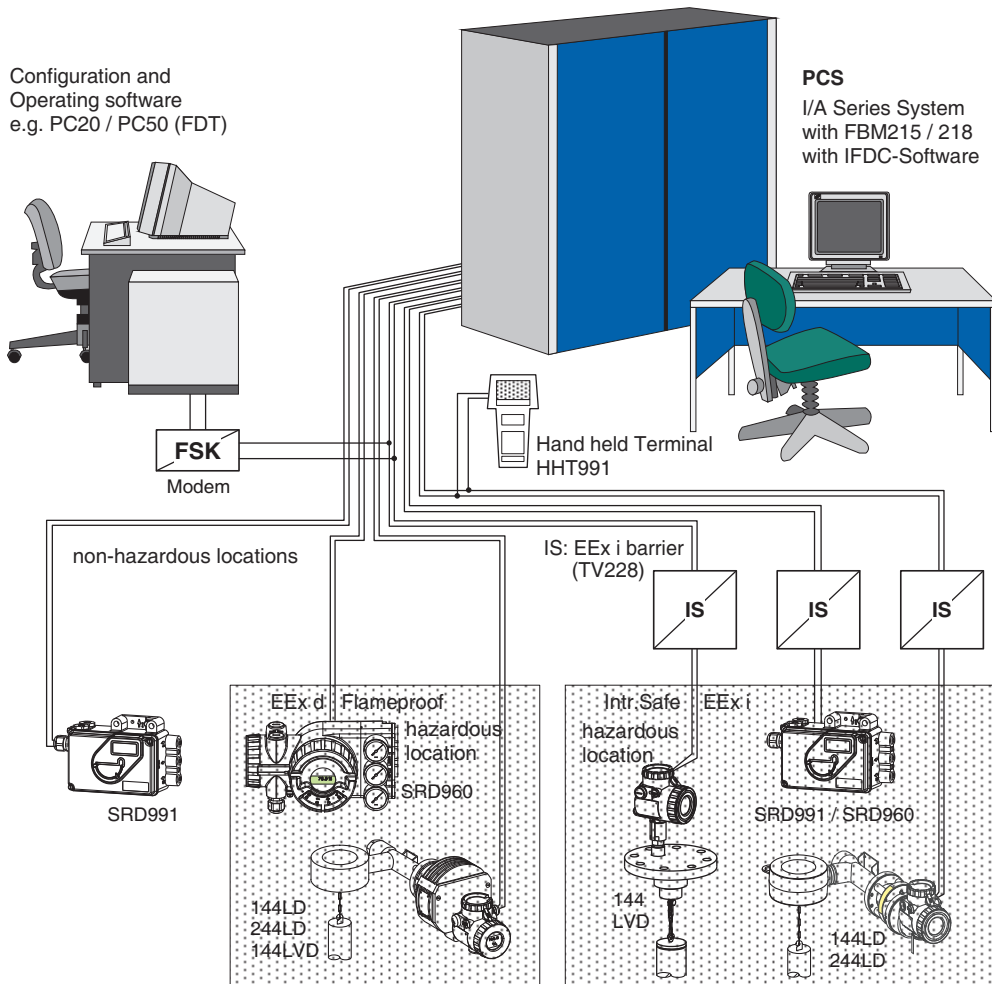

### Summary – FOUNDATION Fieldbus

Start-up according to following steps:

#### Mounting to Actuator (Valve)

The SRD991 can be mounted to linear or rotary actuators. More see page 11.

#### Connection and Start-up

Upon connection of supply air and a voltage source of e.g. DC 24 V to the input terminals (polarity is random, see page 20) an initial start-up can be carried out without any further equipment.

With the local push buttons, basic parameters can be changed, such as type of actuator, side of installation, valve opens/closes with increasing set point value, and characteristics curve of the valve (values set ex-factory: stroke actuator, mounting side: left, valve opens with increasing set point value, linear characteristics curve).

Thereafter an AUTOSTART can be performed; during which the SRD991 determines independently the geometric data of the actuator as well as control parameters, to ensure an optimized operation with the attached valve. More see page 23.

#### Bus Connection

The SRD 991 in the version FOUNDATION Fieldbus is bus compatible, which means that to a 2-core lead, the instruments have to be attached in parallel according to IEC 1158-2. The lead serves as voltage feeder as well as for digital communication.

A FOUNDATION Fieldbus can consist of one or several segments, each with an individual length of up to 1900 m. An Ex-barrier should not have a further distance than 100 m from a bus terminal. To a segment up to 32 instruments can be attached. A maximum of up to 240 instruments can be addressed (including repeater = connector of segments). To activate each instrument individually, an individual address has to be entered.

From the factory, the address 29h (41) is always stored. This address can be changed automatically with the NI Configurator.

#### System Integration

With the NI-Configurator changes in the configuration of the SRD991 can be carried out. The required files (\*.FFO, \*.SYM, \*.CFF) can be downloaded from the Internet.

There, a further document is made available, which explains the communication data and parameters in detail.

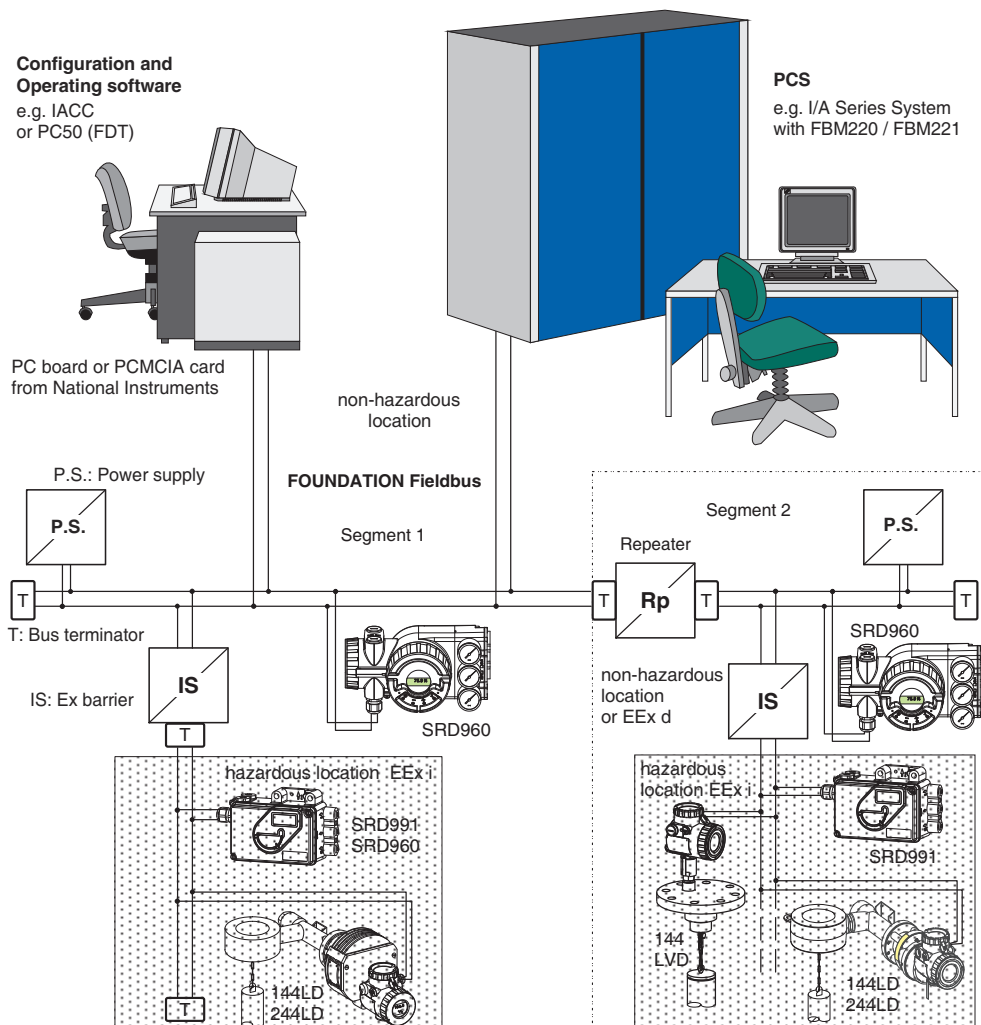

More information about FOUNDATION Fieldbus at [www.fieldbus.org](http://www.fieldbus.org)

## Summary – PROFIBUS-PA

Start-up according to following steps:

### Mounting to Actuator (Valve)

The SRD991 can be mounted to linear or rotary actuators. More see page 11.

### Connection and Start-up

More see page 19.

Upon connection of supply air and a voltage source of e.g. DC 24 V to the input terminals (polarity is random, see page 20) an initial start-up can be carried out without any further equipment.

With the local push buttons, basic parameters can be changed such as type of actuator, side of installation, valve opens/closes with increasing set point value, and characteristics curve of the valve (values set ex-factory: stroke actuator, mounting side: left, valve opens with increasing set point value, linear characteristics curve).

Thereafter an AUTOSTART can be performed; during which the SRD991 determines independently the geometric data of the actuator as well as control parameters, to ensure an optimized operation with the attached valve. More see page 23.

### Bus Connection

The SRD 991 in the version PROFIBUS-PA is bus compatible, which means that to a 2-core lead the instruments have to be attached in parallel according to IEC 1158-2. The lead serves as voltage feeder as well as for digital communication. To activate each instrument individually, an individual address has to be entered.

From the factory the address 126 is always stored <sup>1)</sup>; since this address cannot be used during operation, a new address has to be entered in every instrument. This can be done via the local keys, with the FDT/DTM software or a commercial configurator.

To a PROFIBUS-PA-segment with a length of up to 1900 m, up to 32 instruments can be attached. A maximum of up to 126 instruments can be addressed with PROFIBUS.

### System Integration

During operation the SRD991 will communicate with a PROFIBUS master class 1. The required GSD file ("instrument specific dates") can be downloaded from the Internet.

There, a further document is made available, which explains the communication data and parameters in detail.

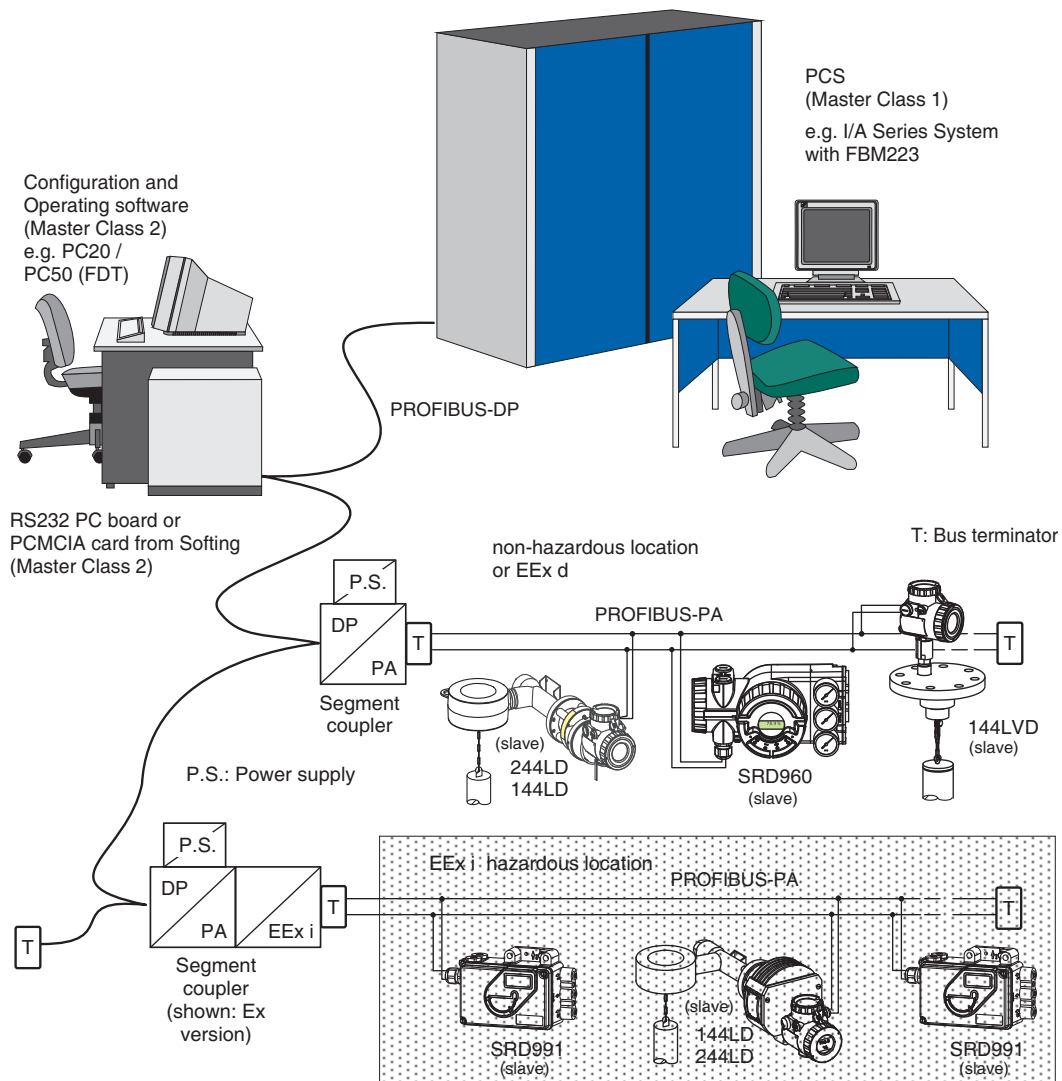

More information about FOUNDATION Fieldbus at [www.fieldbus.org](http://www.fieldbus.org)

## 1 METHOD OF OPERATION

### 1.1 General

The intelligent positioner SRD991 **1** and the pneumatic actuator **2** form a control loop with the set point value  $w$  (from master controller or control system), the output pressure  $y$  and the position  $x$  of the actuator on valve **3**.

Fig.: Fieldbus version

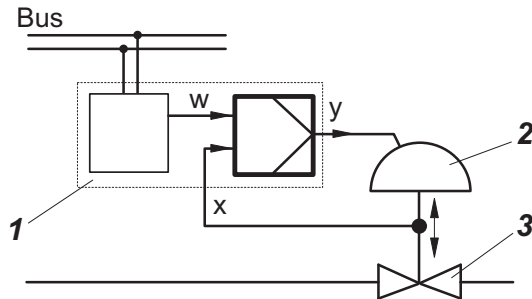

For the supply air, we recommend the FRS923 filter regulator.

The positioner can be attached to both linear and rotary actuators.

Actuators with spring force are controlled by a single acting positioner. Actuators without spring force are controlled by a double acting positioner.

HART version:

The positioner can be operated locally by means of local keys, Hand Held Terminal, remotely via PC based configuration or a corresponding control system, e.g. I/A Series System.

PROFIBUS-PA or FOUNDATION Fieldbus version:

The positioner can be operated locally by means of local keys, remotely via a corresponding control system, or can be operated via PC-based configuration and operating tools e.g. FDT / DTM software.

### 1.2 Block diagram

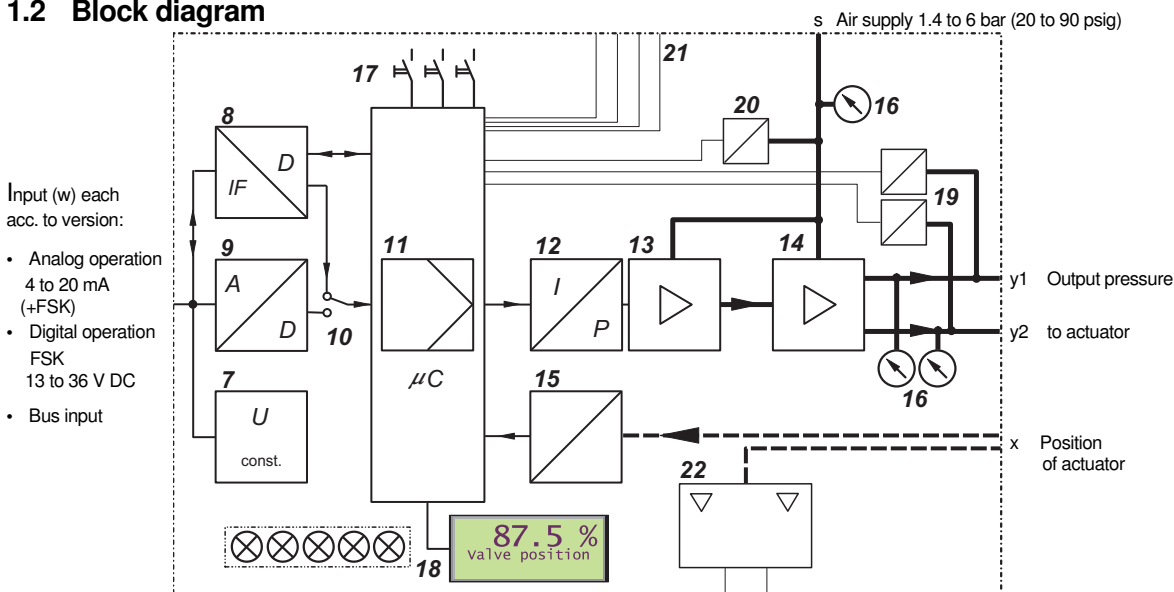

### 1.3 Operation

With the intelligent positioner with input signal 4-20 mA or superimposed HART signal, the supply takes place via the power signal adjacent to the input.

By means of voltage converter **7**, derivation of the internal supply of the electronics takes place. The power value is measured, in A/D transformer **9** converted, and directed via switch **10** to digital controller **11**.

With PROFIBUS-PA or FOUNDATION Fieldbus, the SRD is powered by means of the bus cable. The positioner is operated from a control system by sending a set point (set-point value) to the positioner. The digital signal is directed via the interface component **8** to the digital controller **11**. By means of the voltage converter **7** the internal supply of the electronics is established, fed via the bus cable.

The output of controller **11** drives the electro-pneumatic converter (IP-module) **12**, controlling a pre-amplifier **13**, the single acting (or double acting) pneumatic power amplifier **14**. The output of the amplifier **14** is the output pressure  $y$  to the actuator.

The pneumatic amplifiers are supplied with supply air  $s$  1.4 to 6 bar (20 to 90 psig).

The position  $x$  of the actuator is sent to the control unit **11** by the position sensor **15** (conductive plastic potentiometer). Optional gauges **16**, pressure sensors **19**, **20**, inputs / outputs **21** (two binary outputs; a 4-20 mA output and alarm; control inputs for 'Open/Close' and 'Hold last value') enable additional diagnostic indications and possible intervention. The mechanical limit switch **22** (optional) enables independent alarm signals.

Adjusting, start-up of the positioner as well as the demand for internal information can be made using the local keys **17** with indication given by LCD **18** or LEDs.

## 2 OPERATING MODES

Operation of the positioner is divided into individual 'operating modes'. Operating modes may change depending on, for example, key commands or internal calculations.

The different operating modes are described in abbreviated form below.

### INITIALIZE:

Upon power-up or Reset (pressing of the 3 keys simultaneously), several self-tests are conducted. Individual steps in the self-test process are indicated by the LCD or green LEDs.

If no error occurs the device moves to OUT OF SERVICE, if it is still in a delivery condition; AUTOSTART has to be performed. If AUTOSTART was done already, the device will go to IN OPERATION.

If faults are detected, the code of the faulty self-test will remain (see page 47). If error reoccurs after reset, please check troubleshooting guide or contact customer service.

### DEVICE FAULT:

In the event that the LCD shows a message (or red LED lights up constantly and all green LEDs are off), a device fault is signaled. These faults are detected during cyclical self-test.

The device can no longer be operated. This could be caused by a jammed menu key, defective program memory, etc. (see chapter "Trouble-shooting").

If a device error occurs repeatedly, please contact customer service.

### IN OPERATION:

After performing an AUTOSTART, the device moves to IN OPERATION and will always, even after restarting or re-setting, move back to the safety position (de-energized valve position) or FAILSAFE. If set point values are fed via communication, the SRD will go to IN OPERATION.

### FAILSAFE:

(with FF H1 and Profibus PA communication)

Positioner carries out actions as configured in menu "failure handling". Additionally, the cyclical self-diagnosis takes place.

If the instrument is IN OPERATION, but no set point values arrive via communication, the SRD will go to FAILSAFE mode, after a defined time period; either with

- maintaining last value
- output pressureless, or
- predetermined position.

As soon as set point values arrive via communication again, the instrument is immediately back IN OPERATION.

### OUT OF SERVICE:

The SRD991 in delivered condition is configured in such a way that it will remain OUT OF SERVICE after power-up until moving to IN OPERATION via the manually initiated function AUTOSTART.

In the device state OUT OF SERVICE, the menu entering mode remains active at all times. If a device has been IN OPERATION already and is removed from an actuator and mounted to another, it is recommended to take the device out of operation via RESET CONFIG (Menu 9.1) prior to disconnecting the device from the first actuator.

This enables the next actuator to be started in the delivered condition (see chapter 8).

### CALIBRATE:

During an AUTOSTART function the device is in condition CALIBRATION. The actuator is moved up- and downward several times, and the device could be busy for a few minutes.

Subsequently, the device moves to IN OPERATION.

### MESSAGE:

The SRD991 continuously supervises important device functions. In the event that limit values are exceeded or operational problems occur, messages are signaled via the LCD or the special LED blinking mode.

The message with the highest priority will be indicated first. With key DOWN additional messages can be called up, with key UP the measuring values can be retrieved. It is possible at all times to reach the menu by pressing the menu keys to possibly eliminate the problem by performing suitable menu functions. Further references may be found in chapter "Trouble-shooting".

### SIMULATE (FOUNDATION FIELDBUS version only)

During function IN OPERATION, the valve position queried via the communication, can be simulated with a value that has been entered via communication into the instrument during position SIMULATION. Thereby the positioner continues with normal operation and regulates to the "accurate" set value.

For the SRD, this function has to be additionally released or blocked via menu 10.

LCD description, definition of the LEDs and possible operator interventions are described in chapter START-UP.



**3 FUNCTIONAL DESIGNATIONS**

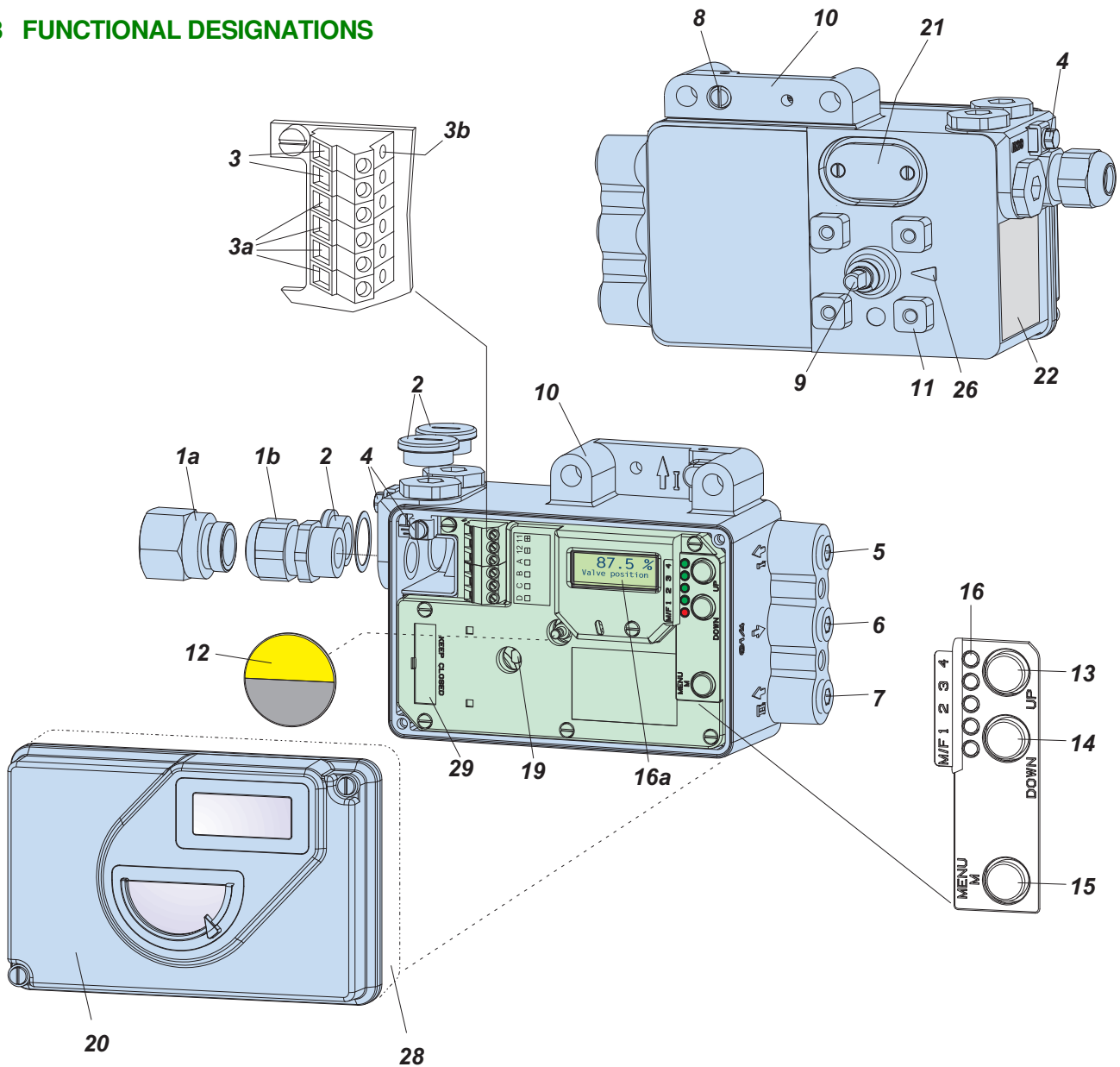

- 1a** Adapter, e.g. 1/2"-14 NPT
- 1b** Cable gland
- 2** Plug, interchangeable with Pos. **1**
- 3** Screw terminals <sup>1)</sup> (11 / 12) for input (w) or for bus connection IEC 1158-2 <sup>3)</sup>
- 3a** Screw terminals <sup>1)</sup> for additional inputs / outputs
- 3b** Test sockets Ø 2 mm, integrated in terminal block
- 4** Ground connection
- 5** Female thread <sup>G)</sup> 1/4 -18 NPT or output I (y1)
- 6** Female thread <sup>G)</sup> 1/4 -18 NPT for air supply (s)
- 7** Female thread <sup>G)</sup> 1/4 -18 NPT or output II (y2)
- 8** Direct attachment hole for output I (y1)
- 9** Feedback shaft
- 10** Connection manifold for attachment to stroke actuators (Not with VDI/VDE 3847 version)
- 11** Connection base for attachment to rotary actuators
- 12** Travel indicator

- 13** Key **UP**
- 14** Key **DOWN**
- 15** Key **M** (Menu)
- 16** Status display (1 red LED, 4 green LEDs) <sup>2)</sup>
- 16a** LCD with true text in 3 different languages
- 19** Fixing shaft for limit switch
- 20** Cover with window to **12**
- 21** Air vent, dust and water protected
- 22** Data label
- 26** Arrow is perpendicular to shaft **9** at angle 0 degree
- 27** Ball valve for protection class NEMA 4X
- 28** High cover with built-in limit switch
- 29** Plug for service connector
- 30** IrCom interface

G) With marked letter "G" in the housing the pneumatic connecting threads are cut as G 1/4 instead of 1/4-18 NPT

1) Alternatively Cage clamps (WAGO) instead of screw terminals

2) Depending on the version, the device is equipped with or without LEDs

### 3.1 Pneumatic Accessories

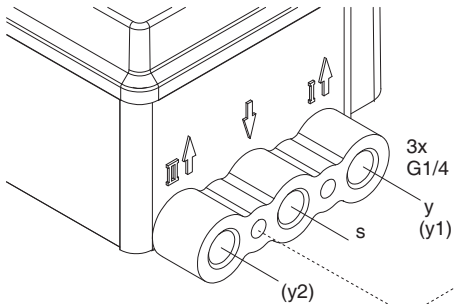

When mounting, check the proper seating of the O-rings and bolt on the accessories with the two M8 bolts. Unused outputs are closed by means of plastic plugs.

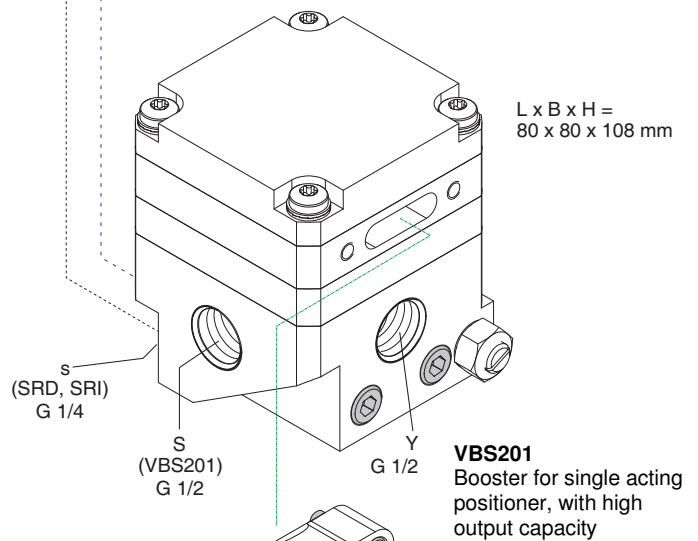
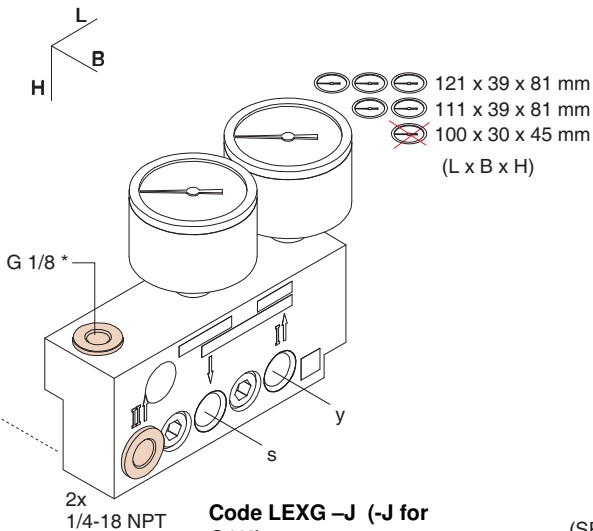
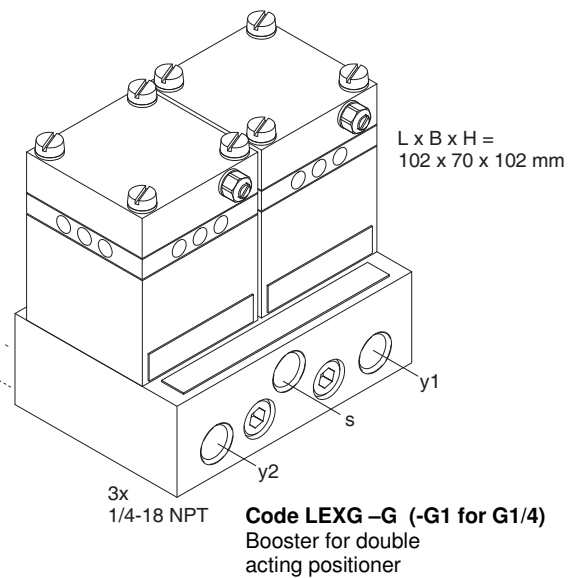
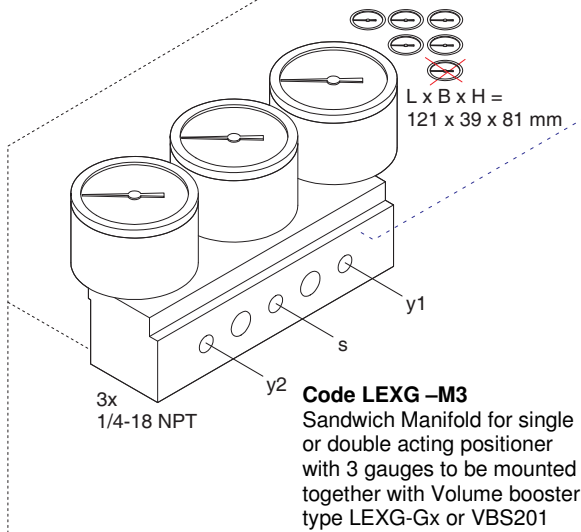
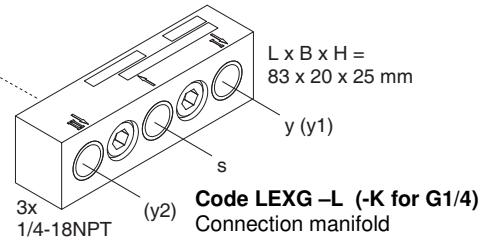

**Code LEXG-M (-M for G1/4)**  
Connection manifold for double acting positioner with pressure gauges for supply air s and output y1 and y2

**Code LEXG-N (-N for G1/4)**  
as -M, M1, but without pressure gauges

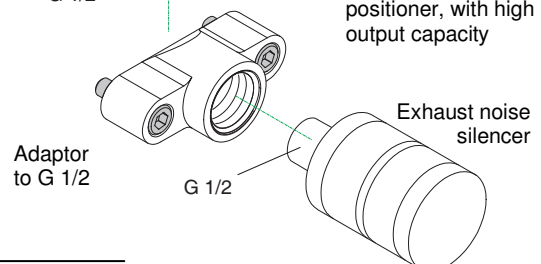

\* Unused threads for pressure are closed by means of lock screw Part No. 425 024 013

## 4 MOUNTING TO ACTUATORS

### 4.1 NAMUR Mounting linear actuator, left hand

Applicable to actuators with cast yoke or pillar yoke acc. to NAMUR (DIN IEC 534-6).

Mounting the positioner with pneumatic connections on the left side and electrical connections on the lower right side.

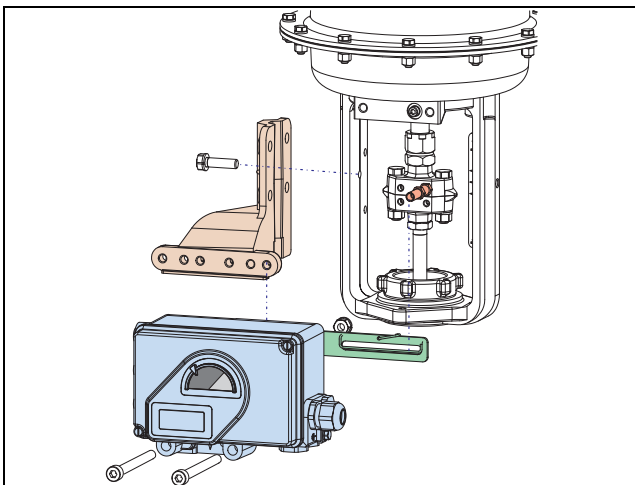

Attachment of the positioner to the actuator is made to the left using the mounting bracket and feedback lever for a NAMUR mount. Use:  
attachment kit EBZG -H for a cast yoke, or  
attachment kit EBZG -K for a pillar yoke.

The side outputs I (or I and II, see page 19) are used.  
The rear output I is closed by means of a lock screw  
522 588 013.

Pneumatic connections: Do not use Teflon tape for sealant. The fine fibers could disturb the function of the SRD. Use only Loctite® #243 for sealant<sup>1)</sup>.

Screw-type glands for electrical connections are positioned on the lower or right side. Any unused threaded holes are closed by plugs.

If housing cover has an air vent, this air vent must face down when mounted.

#### 4.1.1 Preparation of the positioner

Rotate the shaft stub of shaft **9** so that the flat on the shaft stub is perpendicular to the arrow **26** on the housing at mid travel range (detail see page 16). Fasten the feedback lever **A** to the shaft by means of spring washer and nut M8.

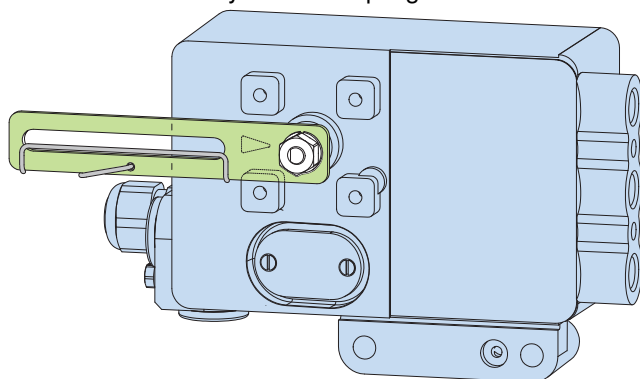

#### 4.1.2 Preparation of the actuator

Screw the carrier bolt to the stem connector (see page 16) and lock it by means of a counter nut.

A carrier bolt with an adjustable length is used to be able to screw on various coupling pieces.

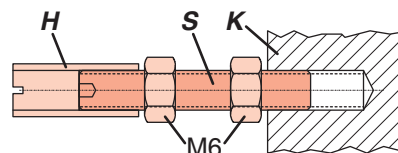

It consists of a stud **S**, which is screwed into the coupling piece **K** (with 3 mm Allen key) and locked with a lock nut **M6**. The threaded sleeve **H** is screwed onto it and locked with a lock nut **M6**. Make sure that the bolt is adjusted to the right length!

Fasten the mounting bracket to the left side of the yoke. For a cast yoke use a screw M8 x 30, for a pillar yoke use two U-bolts and four nuts.

#### 4.1.3 Mounting of the positioner

Fasten the positioner to the mounting bracket using two spring washers and two screws M8 x 80.

Note, the carrier bolt **B** is in the slot of the feedback lever **A** and the compensating spring **F** touches the carrier bolt.

Fig.: Feedback lever

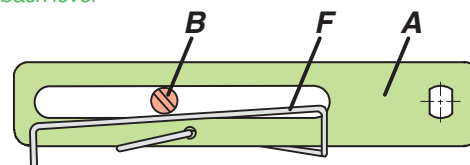

For optimum utilization of the positioner operating range, it is recommended that the arrangement is adjusted according to the following procedure before fixing. At an actuator position in the middle of travel range, the feedback lever position should be perpendicular to the actuator stem<sup>2)</sup> and the angle range should be between  $-10^\circ$  to  $+10^\circ$  and  $-45^\circ$  to  $+45^\circ$ .

Fasten the positioner to the mounting bracket so that a suitable angle range is selected.

It is recommended that the pneumatic and electrical connections are made after adjusting the position.

1) Apply only to male thread

2) Fine adjustment with menu "5.11 Valve corr."

### 4.1.4 NAMUR Mounting Dimensions – left hand –

LCD orientation can be changed by means of local push buttons under Menu 9.10.2 to „flipped“, to ensure a correct orientation of the display.

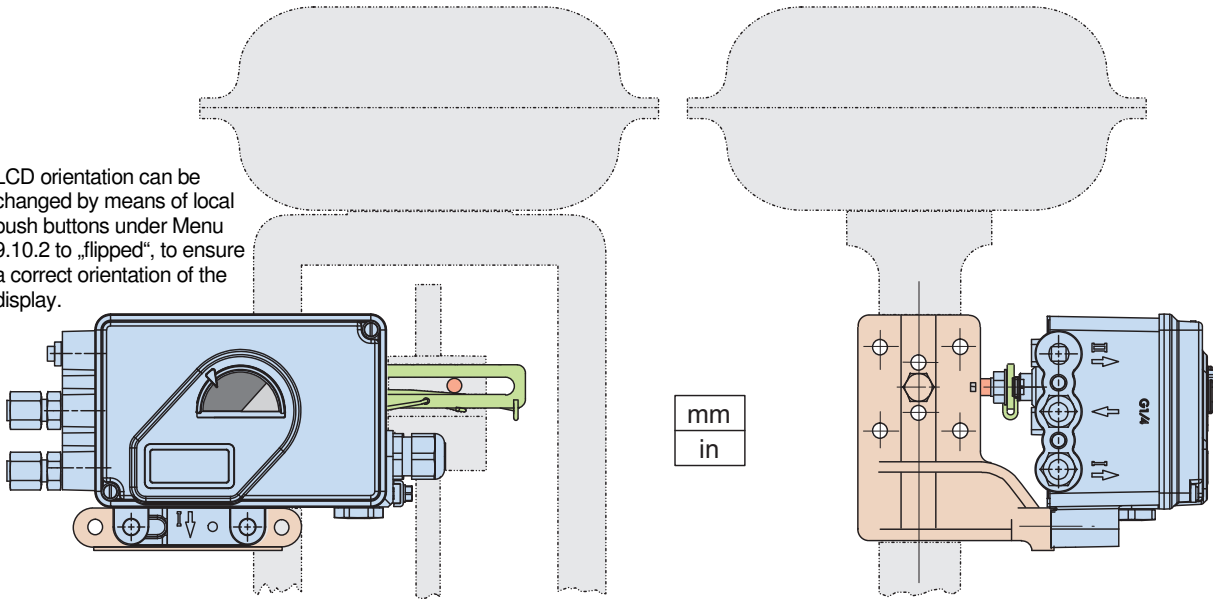

**Attachment to casting yoke**  
(with attachment kit  
Code EBZG-H)

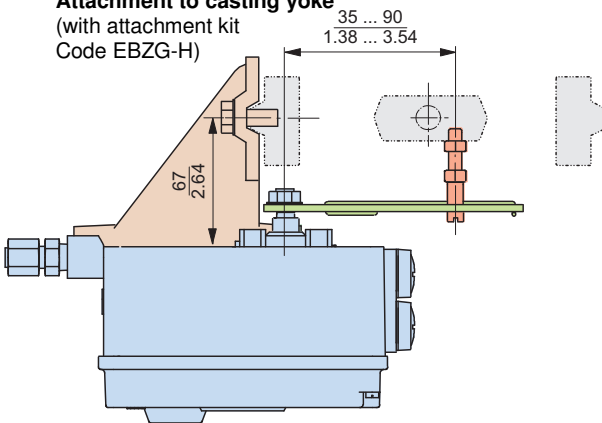

**Attachment to pillar yoke**  
(with attachment kit  
Code EBZG-K)

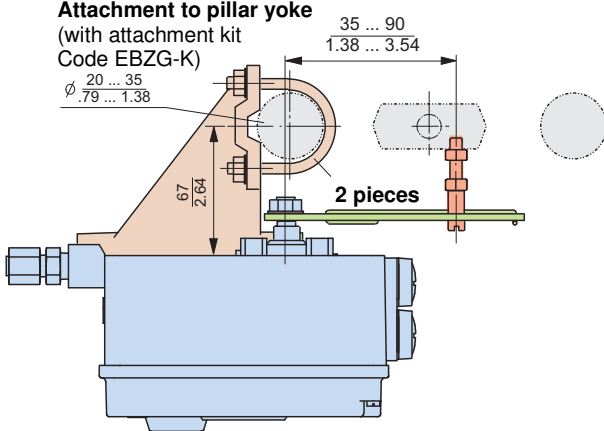

**Carrier bolt** for connection to valve stem

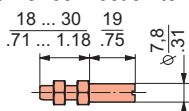

**Mounting bracket**

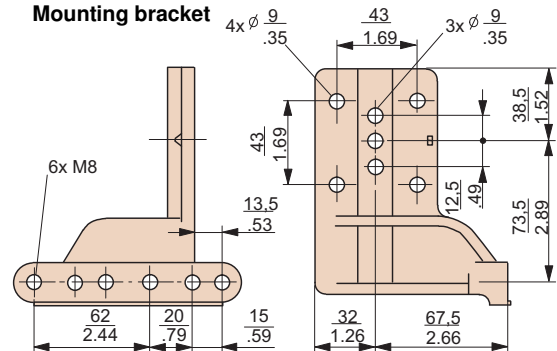

**Feedback lever** Code EBZG-A for 8 to 70 mm travel

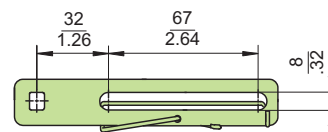

**Feedback lever** Code EBZG-B for 60 to 120 mm travel

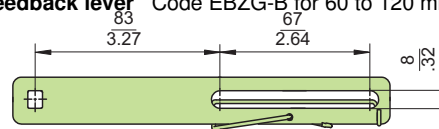

## 4.2 NAMUR Mounting linear actuator, right hand

Right-hand mounting is done if for instance left-hand mounting is not possible for structural reasons.

Applicable to actuators with cast yoke or pillar yoke acc. to NAMUR (DIN IEC 534-6).

Mounting the positioner with pneumatic connections on the right side and electrical connections on the left side.

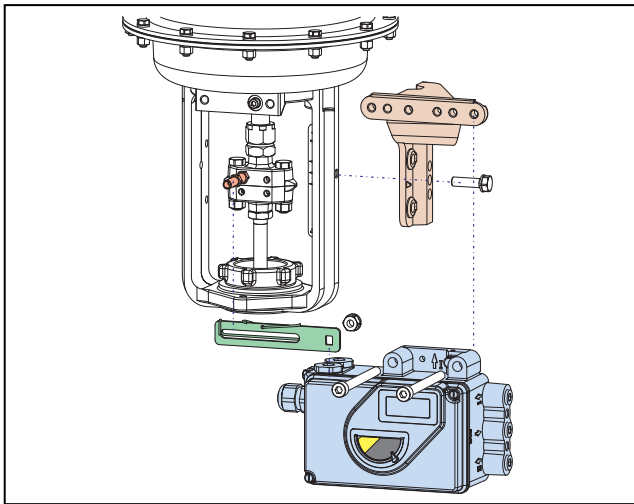

Attachment of the positioner to the actuator is made to the right using the mounting bracket and feedback lever for a NAMUR mount. Use:

attachment kit EBZG -H for a cast yoke, or attachment kit EBZG -K for a pillar yoke.

The side outputs I (or I and II, see page 19) are used.

The rear output I is closed by means of a lock screw 522 588 013.

Pneumatic connections: Do not use Teflon tape for sealant. The fine fibers could disturb the function of the SRD. Use only Loctite® #243 for sealant<sup>1)</sup>.

Screw-type glands for electrical connections are positioned on the left side. Any unused threaded holes are closed by plugs.

If housing cover has an air vent, this air vent must face-down when mounted.

### 4.2.1 Preparation of the positioner

Rotate the shaft stub of shaft **9** so that the flat on the shaft stub is perpendicular to the arrow **26** on the housing at mid travel range (detail see page 16). Fasten the feedback lever **A** to the shaft by means of spring washer and nut M8.

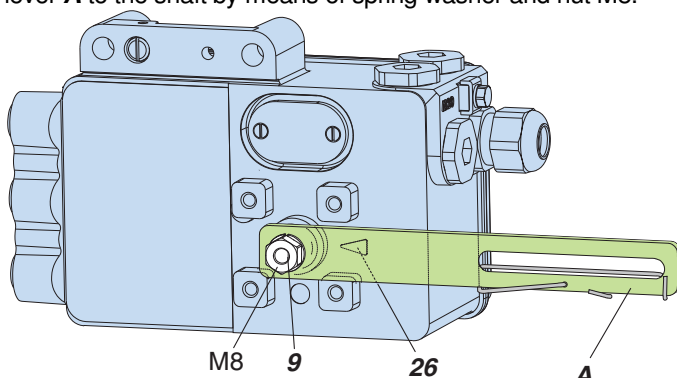

### 4.2.2 Preparation of the actuator

Screw the carrier bolt to the stem connector (see page 16) and lock it by means of a counter nut.

A carrier bolt with an adjustable length is used to be able to screw on various coupling pieces.

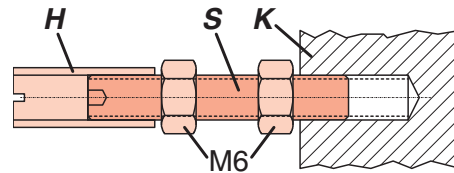

It consists of a stud **S**, which is screwed into the coupling piece **K** (with 3 mm Allen key) and locked with a lock nut M6. The threaded sleeve **H** is screwed onto it and locked with a lock nut M6. Make sure that the bolt is adjusted to the right length!

Fasten the mounting bracket to the left side of the yoke.

For a cast yoke use a screw M8 x 30,

for a pillar yoke use two U-bolts and four nuts.

### 4.2.3 Mounting of the positioner

Fasten the positioner to the mounting bracket using two spring washers and two screws M8 x 80.

Note, the carrier bolt **B** is in the slot of the feedback lever **A** and the compensating spring **F** touches the carrier bolt.

Fig.: Feedback lever

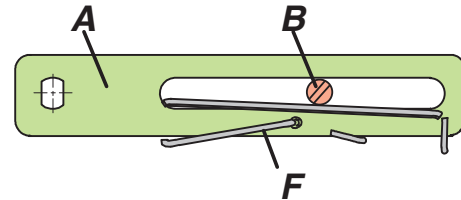

For optimum utilization of the positioner operating range, it is recommended the arrangement be adjusted according to the following procedure before fixing. At an actuator position in the middle of travel range, the feedback lever position should be perpendicular to the actuator stem<sup>2)</sup> and the angle range should be between  $-10^{\circ}$  to  $+10^{\circ}$  and  $-45^{\circ}$  to  $+45^{\circ}$ .

Fasten the positioner to the mounting bracket so that a suitable angle range is selected.

It is recommended that the pneumatic and electrical connections are made after adjusting the position.

1) Apply only to male thread

2) Fine adjustment with menu "5.11 Valve corr."

4.2.4 NAMUR Mounting Dimensions – right hand –

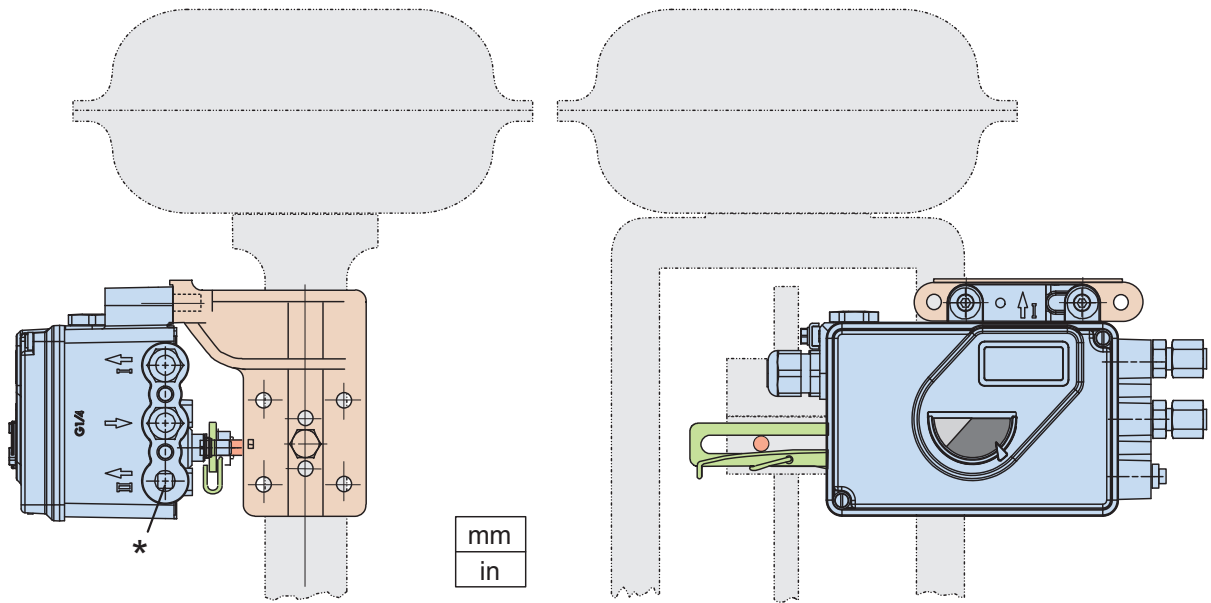

**Attachment to casting yoke**  
(with attachment kit EBZG-H)

Mounting bracket, feedback lever and  
carrier bolt see page 16

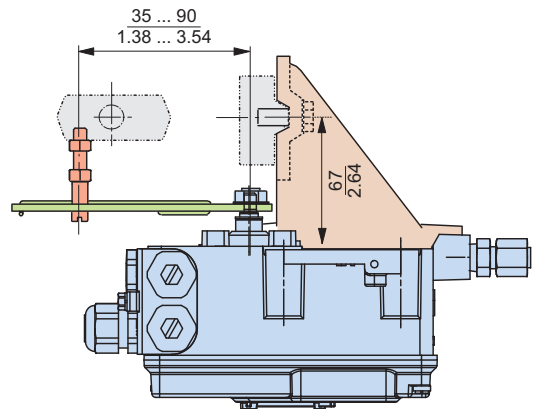

**Attachment to pillar yoke**  
(with attachment kit EBZG-K)

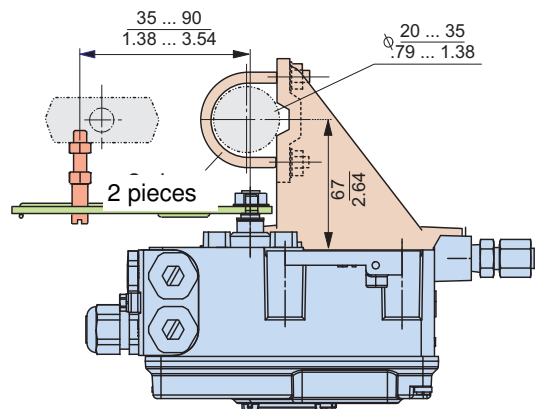

### 4.3 Linear actuator, direct mounting

Actuators with appropriately prepared yoke enable mounting of the SRD directly to the actuator yoke.

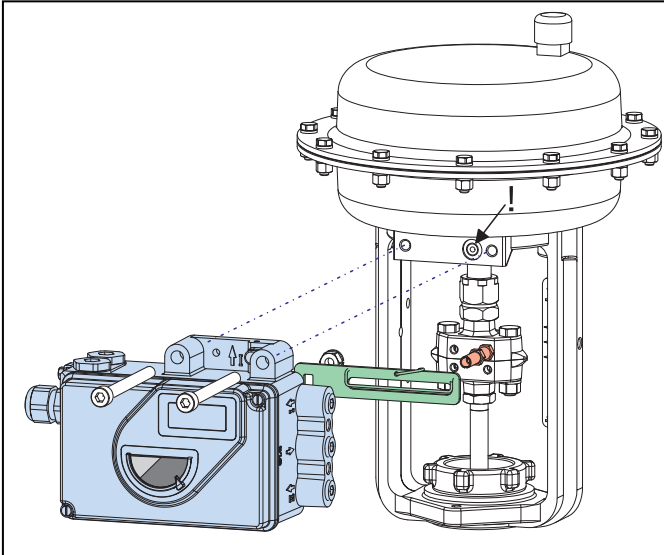

The attachment of the positioner is accomplished by bolting it directly to the actuator yoke using the feedback lever for a direct mount (with attachment kit EBZG -D).

The rear output I and the side outputs I and II are used as follows (see page 19) :

- Actuator single acting, spring force closes:  
The rear output I is used (remove lock screw in hole **D**).  
The side output I is closed by means of a lock screw (see page 19).
- Actuator single acting, spring force opens:  
The side output I is used.  
The rear output I is closed by means of a lock screw.
- Actuator double acting:  
The rear output I and the side output II is used.  
The side output I is closed by means of a lock screw (see page 19).

Pneumatic connections: Do not use Teflon tape for sealant. The fine fibers could disturb the function of the SRD. Use only Loctite® #243 for sealant<sup>1)</sup>.

Screw-type glands for electrical connections are positioned on the side. Any idle female threads are closed by means of plugs.

If housing cover has an air vent, this air vent must face down when mounted.

#### 4.3.1 Preparation of the positioner

Rotate the shaft stub of shaft **9** so that the flat on the shaft stub is perpendicular to the arrow **26** on the housing at mid travel range (detail see page 17). Fasten the feedback lever **A** to the shaft by means of spring washer and nut M8.

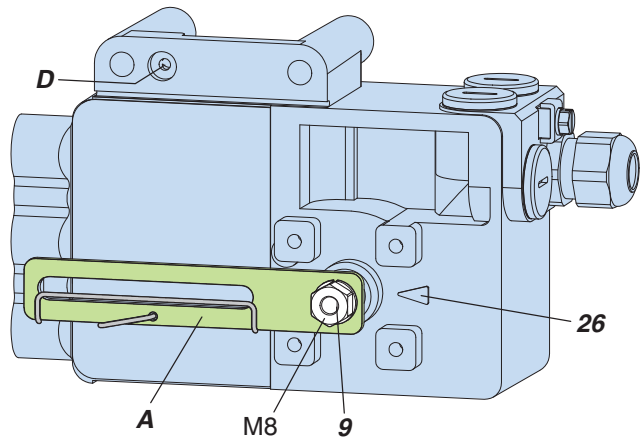

#### 4.3.2 Preparation of the actuator

Screw in the carrier bolt **B** on the coupling piece **K** on the drive spindle **S** at the lower left and lock it by means of a nut M6.

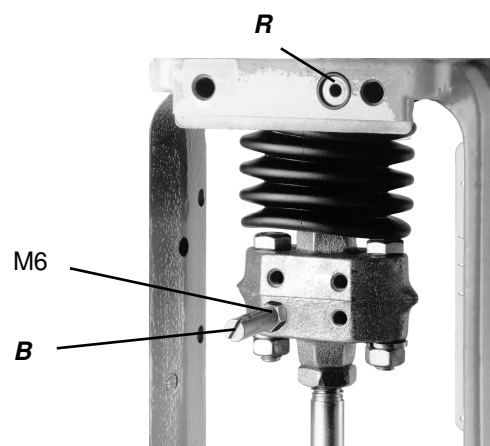

#### 4.3.3 Mounting of the positioner

Fasten the positioner to the upper part of the yoke using 2 spring washers and 2 screws M8 x 80, as shown above. The rear output I of positioner has contact to the air duct **R** in the yoke.

**Attention:** Note the correct position of the O-ring on the yoke for the rear connection !!

Note, the carrier bolt **B** is in the slot of the feedback lever **A** and the compensating spring **F** touches the carrier bolt.

Fig.: Feedback lever

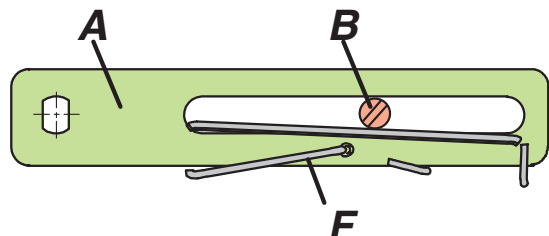

1) Apply only to male thread

4.3.4 Mounting dimensions – direct mounting –

**mm**  
**in**

**Feedback lever** Code EBZG-A for 8..70 mm travel

32 67  
1.26 2.64

8  
.32

**Feedback lever** FoxPak/FoxTop in Code EBZG-E

23 45  
0.91 1.77

8  
.32

**Carrier bolt** for connection to valve stem

19 28  
.75 1.1

7.8  
.31

M6

**Detail:** shaft stub **9** is perpendicular to the arrow **26** on the housing(at mid travel range)

35 ... 90  
1.38 ... 3.54

62 14  
2.44 .55

2x M8

O-Ring 10 x 2

0 ... 50  
... 1.97

Connection to yoke using the direct connection hole for rear output I (y/y1)



## 4.4 Mounting to rotary actuators

Applicable to rotary actuators that meet the VDI/VDE 3845 standard for mounting. Installation position of positioner: Mount the positioner so that the pneumatic connections are in the same direction as the longitudinal drive axis of the actuator as shown in the illustration below.

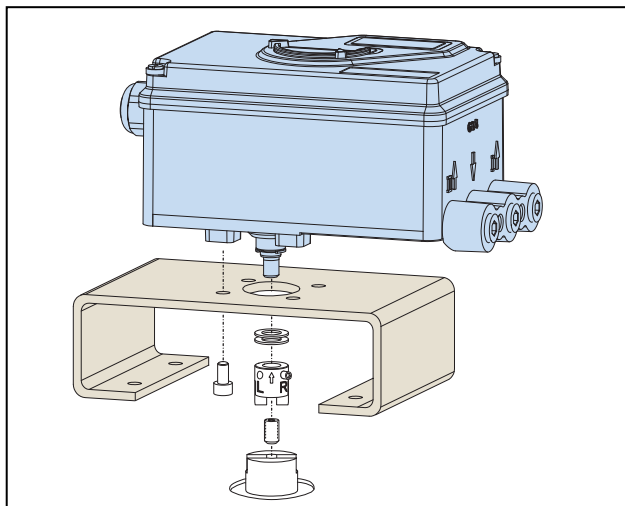

**Attention:** The feedback shaft **9** of the SRD has no mechanical stop, therefore may spin 360 degrees. The permissible rotation angle range is between +50 and -50 degrees around the arrow at the housing concerning the flat area of the feedback shaft (also see detail page 17 bottom). Since a rotary actuator has a rotary angle of about 90 degrees, the mounting as described in the following must be carried out very precisely.

Attachment of the positioner to the actuator is made by using the rotary adaptor kit EBZG -R.

Either the side outputs I (or I and II) are used and the rear output I is closed by means of the lock screw 522 588 013.

Pneumatic connections: Do not use Teflon tape for seal- ant. The fine fibers could disturb the function of the SRD. Use only Loctite® #243 for sealant <sup>1)</sup>.

Screw-type glands for electrical connections are used as needed. Any unused threaded holes are closed by plugs.

**Caution!** Prevent accumulation of water in the instrument in this mounting position by sealing cable entry against water. Provide a continuous supply of dry instrument air.

### 4.4.1 Preparation of positioner

Valve must be in failsafe position and the direction of rotation of the actuator drive shaft must be known. These items are extremely important for proper functioning. These items can be checked as follows in case they are not clear:

- In the single-acting actuator the force of the installed spring closes. The pressure-less actuator is in failsafe position. Through manually feeding compressed air it can be seen whether the actuator drive shaft rotates to the left or to the right.
- In the double-acting actuator (without spring reset) both air chambers are basically equal. Failsafe position can be either "open" or "close". Therefore, indication of the failsafe position has to be determined by engineering. Then the direction of rotation may be determined by manual feeding of compressed air.

Bolt **2** is screwed into actuator drive shaft **1** for subsequent centering of the rotary adaptor **3**. The attachment console is mounted to the stroke actuator (see illustration).

*Attachment diagram for bracket*

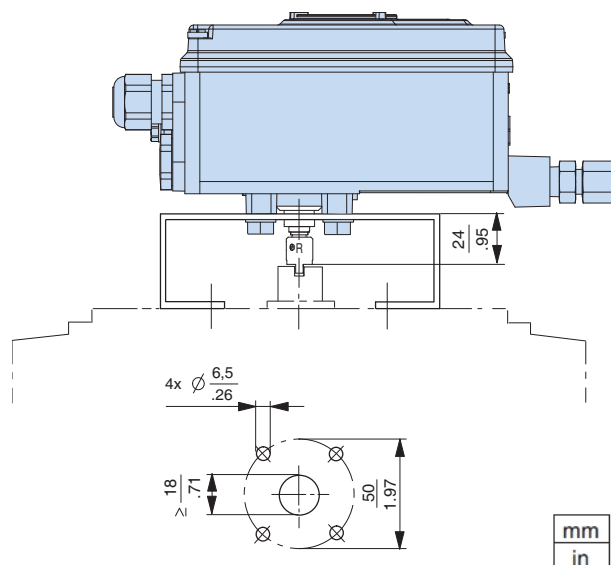

*Rotary adaptor*

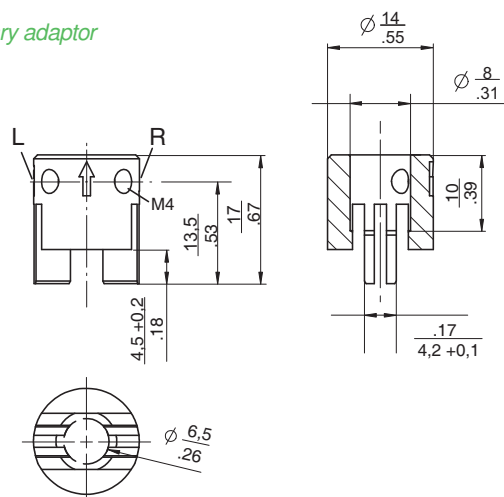

1)..Apply only to male thread

#### 4.4.2 Preparation of the actuator

First the rotary adaptor is being prepared:

For attachment to a counter-clockwise or left turning actuator, secure the stud screw **4** in the threaded hole "L" of the rotary adaptor; hole "R" remains open. See Fig. 27.

For attachment to a clockwise or right turning actuator, secure the stud screw **4** in the threaded hole "R" of the rotary adaptor; hole "L" remains open. See Fig. 28.

Now place the rotary adaptor **3** with two washers **5** on the feedback shaft **9** of the positioner against the stop.

Note:

When the product temperature rises the drive shaft **1** becomes longer. Therefore, the rotary adaptor **3** must be mounted so that approx. 1 mm (0.04 in.) of clearance is between the drive shaft **1** and the rotary adaptor **3**. This is achieved by placing an appropriate number of washers **5** on the feedback shaft stub **9** before attaching the rotary adaptor. Two washers should result in a clearance of 1 mm.

Figure 27: Mounting if actuator is left-rotating.

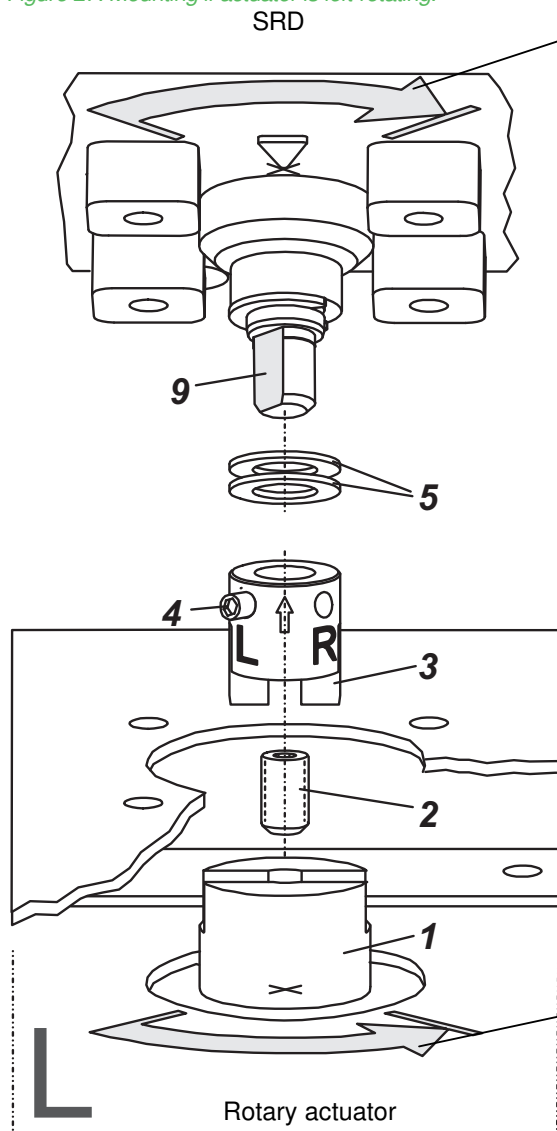

Now screw and tighten the bolt in the coupling against the flat part of the feedback shaft (do not screw against thread!).

Finally turn the feedback shaft in such a way that the arrow of the coupling points to the arrow of the SRD housing. Beginning and end positions of the actuator drive shaft **1** and feedback shaft **9** are marked in figure 27 (left-rotating actuator) and in figure 28 (right-rotating actuator) by arrows for the respective direction of rotation.

The feedback shaft is now in the normal position corresponding to the failsafe position of the actuator.

#### 4.4.3 Mounting of positioner

SRD and actuator are in failsafe position.

Attach the SRD on the console so that the catch of coupling **3** is guided into the groove of shaft **1**. Use bolt **2** to center and align the positioner to the actuator.

Be careful not to shift shafts **1** and **9** and that both shafts are exactly flush.

Fasten the positioner to the bracket by means of 4 lock washers and 4 screws M6 x 12.

Figure 28: Mounting if actuator is right-rotating.

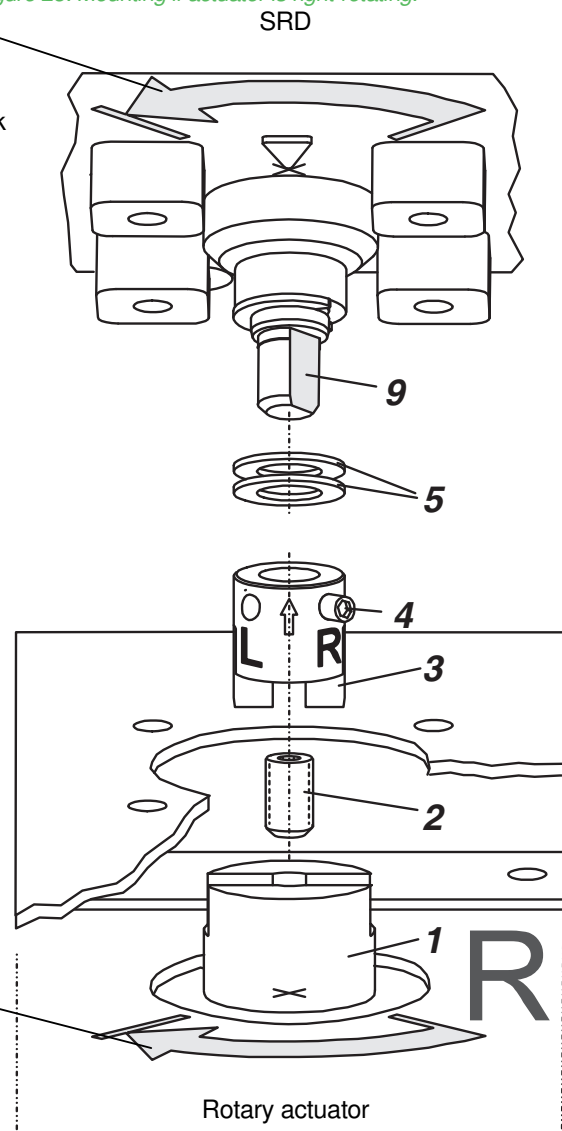

### 5 PNEUMATIC CONNECTIONS

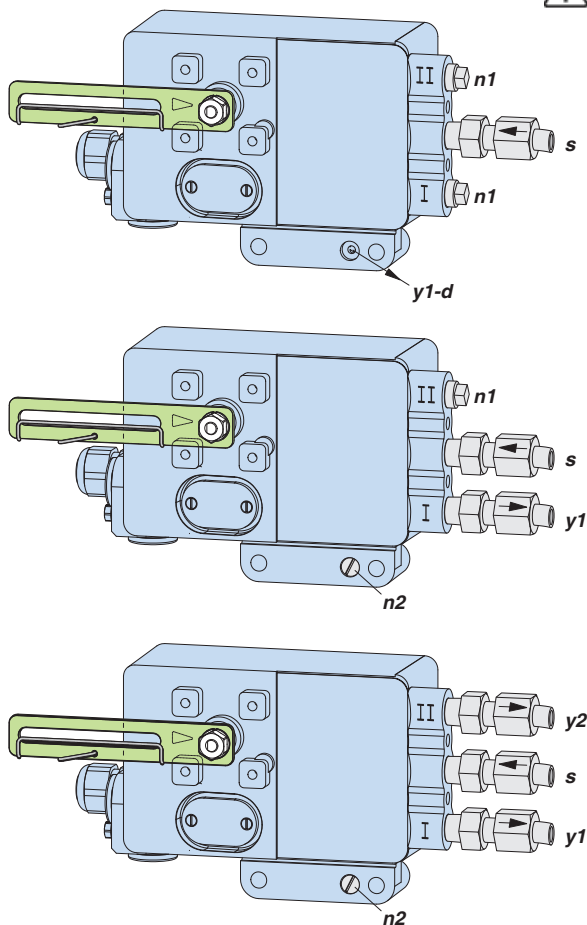

### WARNING

To avoid any personal injury resulting from bursting of parts, do not exceed maximum supply pressure of positioner and actuator. To avoid any personal injury or property damage from sudden or fast movement, during air connection: Do not put your finger or other part at any time inside the valve or in any moving part of the actuator. Do not put your finger or other part at any time in the feedback lever mechanism. Do not touch the rear part of the positioner at any time. Connect air supply only after connection Y1 (and Y2 for double acting) are done.

Following alignment and mounting of the positioner to the valve, pneumatic tubing has to be provided.

#### Explanation of abbreviations:

- s** Supply air
- y1-d** Output 1 for direct mounting, depressurized at currentless electronics. When using this output **y1** has to be closed by means of hex screw.
- y1** Output 1, depressurized at currentless electronics. When using this output, **y1-d** has to be closed by means of sealing screw and O-ring.
- Y2** Output 2 for double-acting actuator. Full pressure at currentless electronics. Closed at single acting actuator.
- n1** Hex screw  
Part No. 522 588 013 (NPT thread, stainless steel)  
Part No. 556 446 016 (NPT thread, plastic)
- n2** Sealing screw with O-ring

Unused pneumatic connections must be closed off.

#### FAIL SAFE POSITION FOR DOUBLE ACTING

Fail safe position of the double acting valve is given by the fail safe action of the pneumatic of the positioner itself. In case positioner is de-energized:

- Output **Y1** is 0
- Output **Y2** is 100% of air supply pressure

Therefore do pneumatic piping of **Y2** to the chamber of the actuator that should be pressurized to do the requested fail safe. In any case put air supply only when the output **Y2** is connected.

#### Supply

- Supply air pressure ..... 1.4 to 6 bar (20 to 90 psig)
  - Air supply ..... according to ISO 8573-1
  - Solid particle size and density class 2
  - Oil rate ..... class 3
  - Pressure dew point 10 K under ambient temperature
- For air supply, we recommend the FRS923 filter regulator.

### 6 ELECTRICAL CONNECTION



### WARNING

To avoid any electrical shock, respect the maximum input supply voltage for the device and options. To avoid any personal injury or property damage from sudden or fast movement, during electrical connection: Do not put your finger or other part at any time inside the valve or in any moving part of the actuator. Do not put your finger or other part at any time in the feedback lever mechanism. Do not touch the rear part of the positioner at any time.

Unused cable glands should be closed off. Feed in the bus cable through the gland **1**. The gland is suitable for cable diameters of 6 to 12 mm (0.24 to 0.47 in). Observe the tightness of the cable entry. Make the electrical connection of the input line at the screw terminals **3b**, whereby with Fieldbus devices no polarity has to be observed. The terminals are suitable for wire cross-sections of 0.3 to 2.5 mm<sup>2</sup> (22 -14 AWG).

- The shield of the bus connection is
  - with conductive cable glands (recommended) directly connected with the housing
  - with non-conductive cable glands to be placed onto the

inner screw terminal 4. Note: When connecting shielded cable connect the cable shield on both sides! (on the positioner as well as on the system side). For selection of cable, see recommendation for cable types acc. to IEC 1158-2.

For connection to a local ground the internal and external ground terminal 4 can be used.

In the connecting terminals test sockets for measuring purposes are integrated. With version HART at clamps 11+ and 12- a hand held terminal or modem for communication can be attached.

## ELECTRICAL CONNECTIONS

The safety requirements of document EX EVE0001 as well as the requirements of PSS EVE0105 and MI EVE0105 for SRD991 must be observed!

### 6.1 Set point Electric Terminal A

#### 6.1.1 SRD991-xD (w/o communication) SRD991-xH (HART)

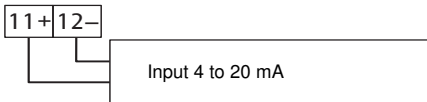

#### 6.1.2 SRD991-xP (PROFIBUS PA) SRD991-xQ (FIELDBUS FF)

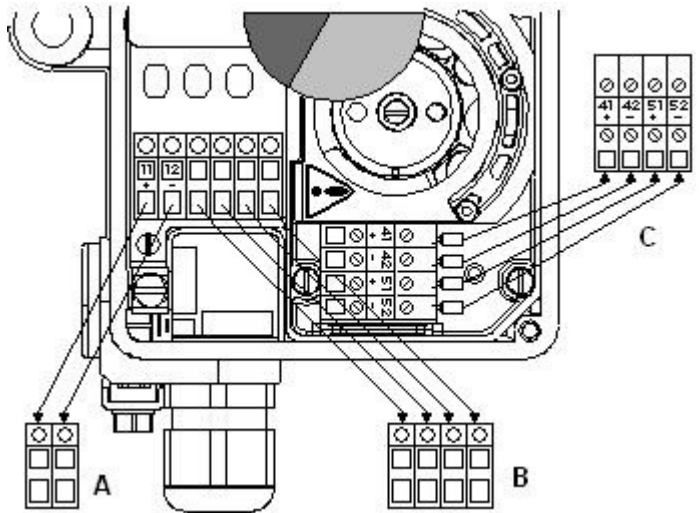
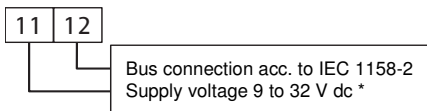

### 6.2 Option Board Electric Terminal B

#### 6.2.1 Two binary inputs (SRD991-xxB)

Binary inputs with internal supply for connection of sensors or switches (switch **closed** for a normal operation)

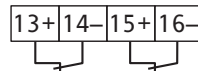

#### 6.2.2 Position feedback 4-20 mA and 1 Alarm (SRD991-xxF)

Analog output 4 to 20 mA and Binary output  
Two-wire system acc. to DIN 19234

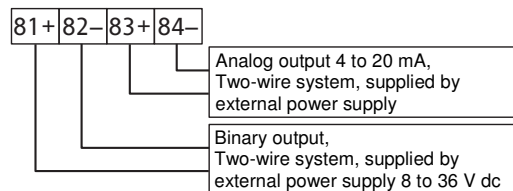

#### 6.2.3 Two binary in-/outputs (SRD991-xxE)

Two-wire system acc. to DIN 19234

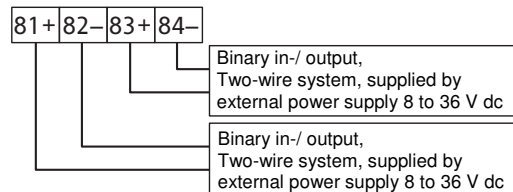

### 6.3 Inductive Limit Switches Terminal C

#### 6.3.1 SRD991-xxxT or U

Two-wire proximity sensors,  
acc. to DIN 19234 or NAMUR

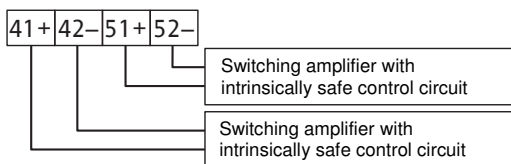

#### 6.3.2 SRD991-xxxR

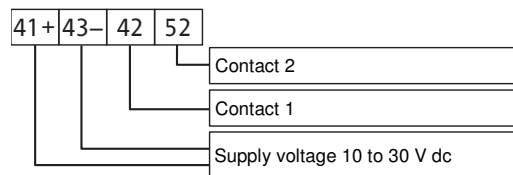

#### 6.3.3 SRD991-xxxV

**Warning:** For connection of micro switches please refer to MI (Master Instruction) and obey the safety requirements described in document EX EVE0001.

\* For intrinsically safe circuits please refer to certificate / data label for max. operating voltages etc.

## 7 OPTIONS

### 7.1 “Limit switch”



#### WARNING

To avoid any personal injury do not touch control vanes during operation.

Remove three screws **A** including tooth lock washer from plastic cover.

Attach limit indicator **B** so that the flattened shaft end **19** contacts the groove of the limit indicator shaft in the positioner.

Attach limit indicator by means of three longer screws **C** and washers.

Test: the coupling shaft at back of positioner should easily be turnable, thereby also moving the vanes of the limit indicator. If this is not the case, loosen screws **C** and flush-align the shafts of positioner and limit switch (turn coupling shaft several times).

Replace short travel indicator **12** by long travel indicator. Screw high cover **28** (or standard cover with insert frame) on housing.

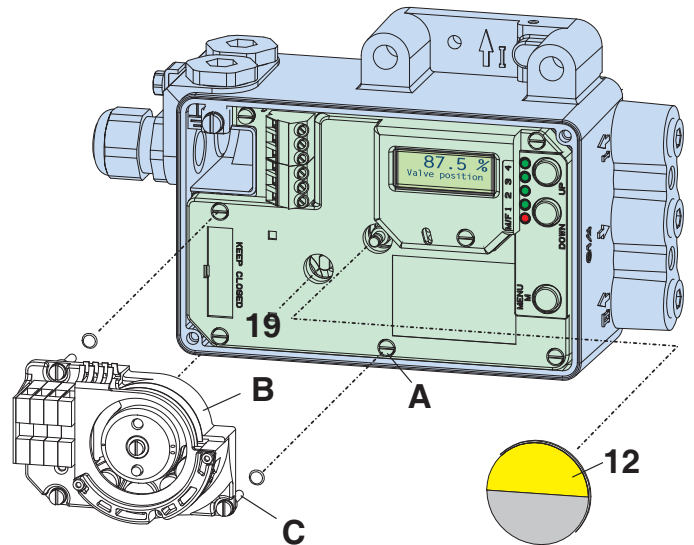

#### Switch functions

Feedback lever, feedback shaft and the control vanes are all connected to each other, without an intermediate transmission. The control vanes are therefore moving simultaneously with the same angle rate as the feedback lever. The length of the control vane corresponds with the swing angle of 120°.

Both control vanes are located on different planes. Each control vane can be seen independently from the other, because each has its own sensor.

By adjusting the screws, the control vanes can be adjusted relatively to the angle rate, so that e.g. one vane dives into and another comes out of the sensor (see illustration).

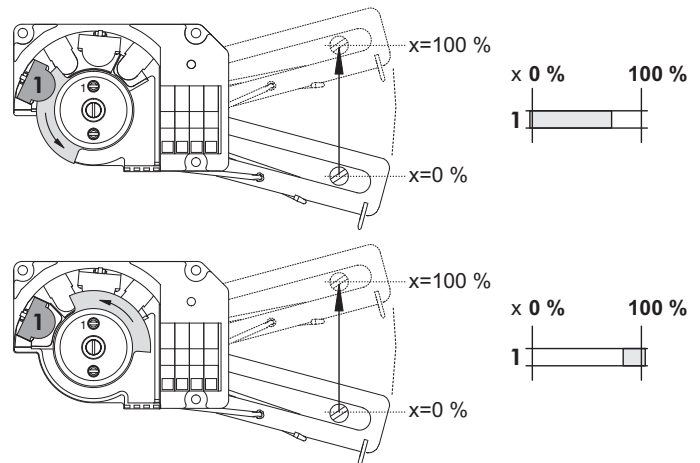

#### Setting limit switch trigger points

First loosen screw **S** until disc **D** is no longer blocked by bolt **B**. Then turn disc by 90°, until set screws **1** and **2** are accessible.

Set trigger point switch GW1:

Turn screw **1** at mark (•), until desired switch behavior is reached.

Set trigger point switch GW2:

Turn screw **2** at mark (••), until desired switch behavior is reached.

To fix switch points turn disc again by 90°, until the bolt catches, then fasten tight the center screw **S**.

Levels of control vanes (illustration without cover)

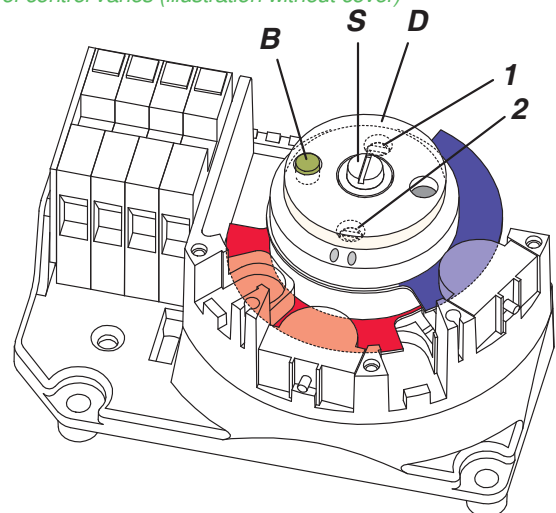

## 7.2 Additional Inputs / Outputs

### General

All versions of the SRD991 are prepared to retrofit this option.

Take current off SRD and turn off supply air. Unscrew cover and remove electronics unit **40** (see page 47).

Attach option board **8** to connection ledge (observe orientation, see illustration). Refasten electronics unit **40**.

After initialization acknowledge message 10 by simultaneous pressing of keys UP + DOWN.

### Option “Position feedback and alarm”

The analog output for position feedback indicates the valve position 0 to 100 % as current signal 4 to 20 mA<sup>1)</sup>. Signal range is 3.8 to 20.5 mA, at fault approx. 0.5 mA.

The binary output for Alarm will be activated in the following cases (see Messages, page 50):

- Calibration error  
(for example due to break-up of calibration) Message 3
- Output outside of limits determined during Autostart  
(Check mounting of feedback lever) Message 5
- Circuit to potentiometer is disturbed  
(cable plugged?) Message 5
- Circuit to IP module is disturbed  
(cable plugged?) Message 6
- No actuator movement; Message 7
- Remaining control deviation (packing is too tight?)  
Message 11

Signal range: 1 mA resp. 4 to 6 mA, at fault < 50 µA.

In the event of disturbances in the electronics of the SRD the Watchdog circuit is activated. The binary output for alarm signalizes this as “cable failure”.

### 7.3 “Built-in pressure sensors”

The pressure sensors **50** are part of the electronics **40**, therefore, the electronics has to be exchanged for conversion to this option.

Disconnect electric power and air supply. Remove cover and electronic unit **40** (see page 46).

Remove, if present, the M3 bolts with sealing washers from both chimneys **52**. Press in a sealing plug **51** Part No. 534 346 013 into the top of each chimney **52** until the collar makes contact. DO NOT GREASE!

To install an electronics unit with pressure sensors, carefully guide the tubes **50** of the pressure sensors vertically into the sealing plugs **51**. Do not twist or tilt the unit. Fasten screws on the electronics unit.

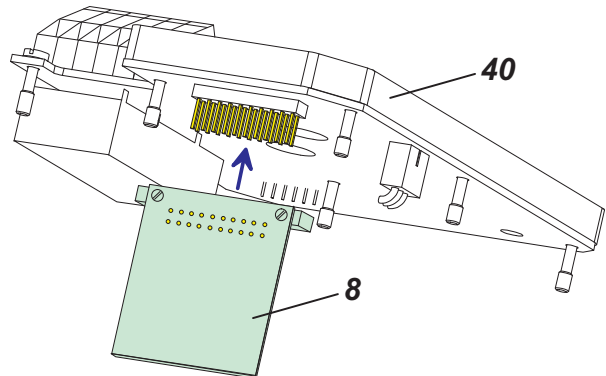

### Option “Two binary outputs”

Both binary outputs AB1 resp. AB2 switch to high current as soon as the valve position is below resp. exceeds the associated limit value. If the binary outputs AB1 resp. AB2 are to be inverted (higher current no alarm, lower current alarm), the association upper/ lower alarm has to be exchanged.

Signal range 1 mA resp. 5 to 6 mA, at fault < 50 µA.

### Option “Binary inputs”

The binary inputs EB1 and EB2 for two external switches resp. sensors initiate the following actions:<sup>2)</sup>

EB1	EB2	Action <sup>2)</sup>
closed	closed	IN SERVICE
open	closed	Position to be operated full power to 0%
closed	open	Position to be operated full power to 100 %
open	open	Hold last value

An input not used is to be short-circuited (wire bridge between + and -).

**Attention:** Even if opening limit or closing limit are set: these actions are superimposed, and the actuator actually moves to 0% resp. 100 %.

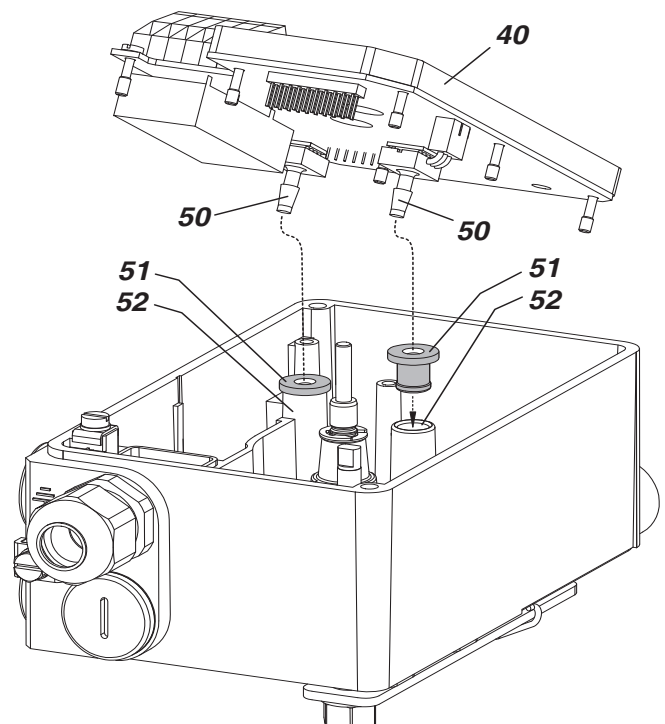

1) The direction of action of the position response message is set:  
valve position 0 % = 4 mA; valve position 100 % = 20 mA  
2) Factory setting. Via communication actions may be turned off or used otherwise.  
EB1 and EB2 can thus also be used as diagnostics inputs.

## 8 START-UP

### WARNING

To avoid any personal injury or property damage from sudden or fast movement, during configuration and Autostart:

Do not put your finger or other part at any time inside the valve or in any moving part of the actuator. Do not put your finger or other part at any time in the feedback lever mechanism. Do not touch the rear part of the positioner at any time.

Ensure you that pneumatic connection is made according chap 5.

#### General

First of all, the nameplate should be checked, especially with respect to indications referring to Ex / non- Ex, input signal, communication, output signal, single / double acting, additional inputs / outputs.

### 8.1 Setting by means of local keys

The SRD991 can be adjusted by means of a local keypad when the cover is off.

- M** (Menu) start menu / end menu
- UP / DOWN** counting up/down of menu numbers resp. parameter numbers
- UP + DOWN simultaneously:** confirm at start, or when entering, storing, or verifying
- M + UP + DOWN simultaneously:** Reset = new start of SRD, thereafter initialization <sup>1)</sup>

#### Indication with LCD

In totally intuitive text:

SRD Main Menu
1 Mounting
2 Autostart
3 Valve Action

Before starting the positioner the SRD has to be mounted to the actuator; power and air supply must be connected. The supply air connection must have sufficient capacity and pressure of 1.4 to 6 bar (20 to 90 psig) and should not exceed the maximum operating pressure of the actuator.

**Attention:** Configuration using local keys or the communication interface may interfere with operation of the actual process! During configuration it is recommended that there is no flow through the valve.

For **Initial Start-up** see next page.

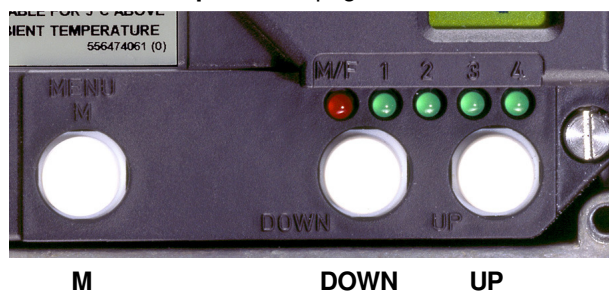

If there is no response using the local key pad (message 1 appears, see page 50) make sure that the Write Protection is not set! Remove the write protection using the FDT/DTM configuration software.

#### Indication with LEDs

The LEDs serve as indication in the following different methods:

M	1	2	3	4	
1/2	1/2	-	-	-	M and LED 1 flash

- 1 constant light, ON
- 1/4 flashing: short ON, long OFF
- 1/2 flashing: ON and OFF same duration
- 3/4 flashing: long ON, short OFF
- OFF

1) The stored data of the positioner is not affected, and remains unchanged

## 8.2 OPERATION

### After Power ON

**INIT:** After power-on of the input signal, or after reset, the SRD initializes, and the various components of the electronics are checked and started. (The stored data of the positioner not affected, and remains unchanged).

The current status is stated on the LCD in clear text or indicated as LED code (see page 48).

Initialization after positioner start-up takes approx. 3 sec, then the SRD goes

- Into operation (Autostart has already been done) or
- To configuration, Menu 9.9 (with LCD the text language is selected before (changing e.g. to French language) ...

9.9 Menu Lang
9.9.1 English
9.9.2 Deutsch
9.9.3 (Francais)

Select with keys  
UP or DOWN and confirm  
with UP+DOWN (together)

... and the display orientation is selected ...

9.10 LCD Orient
9.10.1 Normal
9.10.2 Flipped

... then automatically continued to configuration:

SRD Main Menu
1 Mounting
2 Autostart
3 Valve Action

### Configuration

**MENU:** The various specifications for configuration are arranged in menus:

M	LEDs flash				Menu	Description
	1	2	3	4		
1/2	1/2				1	Actuator system, mounting side
1/2		1/2			2	Autostart, Short Autostart
1/2			1/2		3	Valve function
1/2				1/2	4	Characteristic of set point
1/2	1/2	1/2			5	Limits and Alarms <sup>1)</sup>
1/2	1/2		1/2		6	Parameter for position controller
1/2	1/2			1/2	7	Manual setting of pneumatic output
1/2		1/2	1/2		8	Manual setting of valve position
1/2		1/2		1/2	9	Calibration functions for workshop
1/2			1/2	1/2	10	PROFIBUS-PA: Bus Address FOUNDATION F.: Simulate

1/2 = ON and OFF flashing same duration  
Details of Menus and Parameters see following pages.

### In Operation

After accomplished Autostart, the SRD automatically goes IN OPERATION. (Additional parameters can be configured through pressing of menu key M.)

On the LCD display the process variable is indicated.

87.5 %
Valve Position

(With LED version, all LEDs are off during operation.)

Through pressing of keys UP or DOWN, additional information can be retrieved from the SRD:

Valve position  
Travel position  
Input current  
Digital set point  
Stem set point  
Input pressure  
Output pressure1  
Temperature  
Travel sum  
Valve cycles  
Operation hours  
TAG Number  
TAG Name  
SRD Version

(Certain data is available only with the corresponding options.)

### Manual Operation

Through twice pressing of keys UP+DOWN (together), the SRD goes into manual operation mode, where the valve position can be set manually. Exit of menu by pressing twice of key M.

### Diagnostics during Operation

If the diagnostics determines an occurrence, this is indicated in the bottom line: (resp. blinking code with LEDs).

87.5 %
Valve position
Ctrl diff error

**MESSAGE:** The SRD recognizes an occurrence which the user must eliminate by taking suitable steps (see page 50) in order to continue with operation. This can be e.g. a wrong configuration or missing supply air.

**ERROR:** During self-testing the SRD recognized an error and is no longer operable, see page 48.

1) Versions without LCD: This menu can be configured only with version HART or version "without communication".



**Operation with local keys**

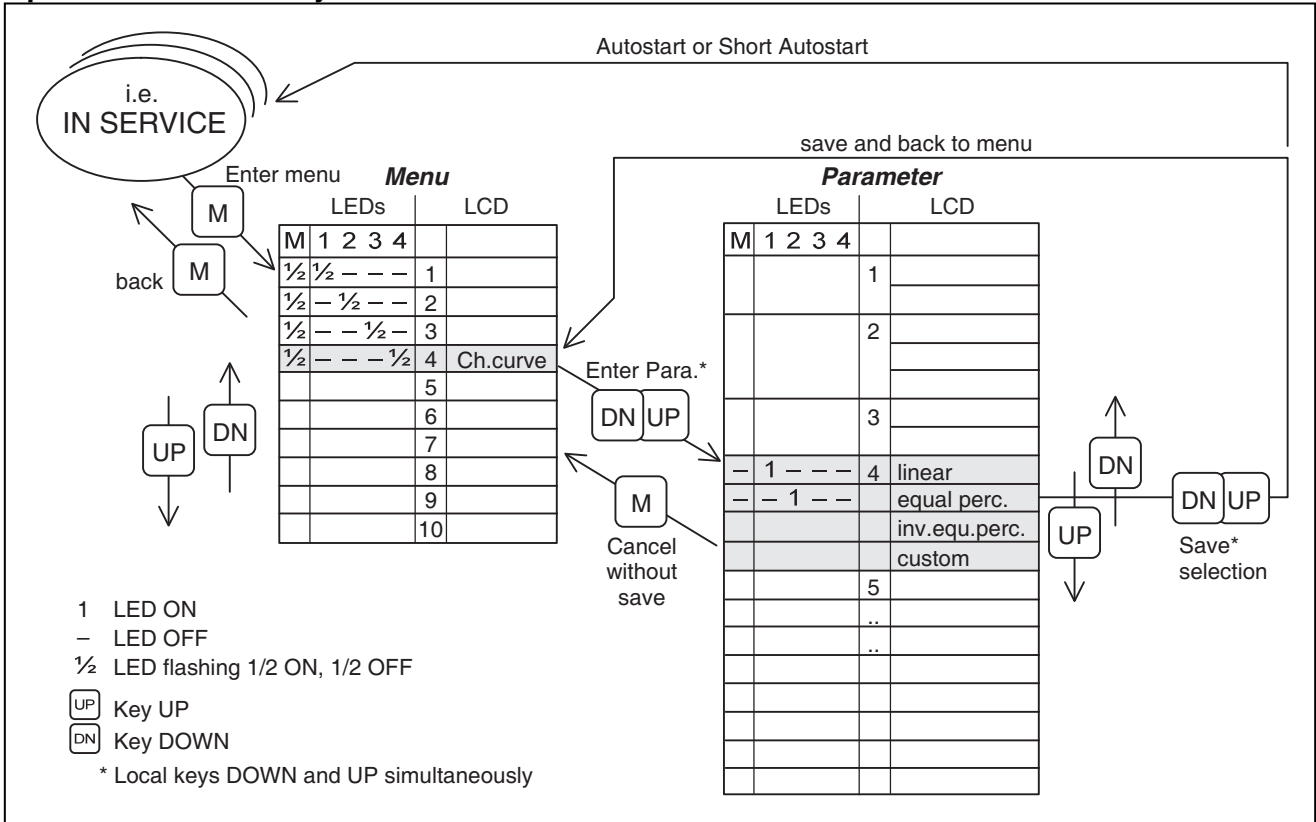

**... with LCD**

- Enter the **Menu** mode by pressing the M key, and Menu 1 appears (see also page 31).
- Select the desired Menu item by pressing the UP or DOWN key, see table. Each press of the key moves one menu item forward (or back).
- Pressing the UP+DOWN (together) key confirms the selected menu item and enters the **Parameter** change mode for the selected menu item.  
To set a parameter see table **Parameter** on next page.
- Leave **Menu** mode by pressing M key again.  
If device remains in menu mode it still is OUT OF SERVICE and AUTOSTART has to be initiated.  
If the instrument is IN OPERATION, the display with the valve position appears.  
If a menu was selected and no further keys are pressed thereafter, the SRD switches automatically back to operation after some minutes.

**... with LED**

- Enter the **Menu** mode by pressing the M key. The red LED flashes alternately with the green LED1, which indicates the Menu item 1.
- Select the desired Menu item by pressing the UP or DOWN key, see table. Each press of the key moves one menu item forward (or back).  
The flashing green LEDs indicate the selected menu item.  
LED test before configuration: Move from menu item 1 to 4 and inspect that each LED lights.
- Pressing the UP+DOWN key (together) confirms the selected menu item and enters the **Parameter** change mode for the selected menu item.  
The red LED goes off and the remaining green LED indicates the parameter or state to be set <sup>1)</sup>.  
To set a parameter see table **Parameter** on next page.
- Leave **Menu** mode by pressing M key again.  
Red and green LEDs extinguish when device is IN SERVICE. If device remains in menu mode it still is OUT OF SERVICE and AUTOSTART has to be initiated.  
If a menu was selected and no further keys are pressed thereafter, the SRD switches automatically back to operation after some minutes.

1) Exception in Menu 6 (and at PROFIBUS Menu 10). No parameter indicated at first, but flashing rhythm with long green and short red phases. This points to a sub-menu.  
Then entry into parameter selection as described.

**MENU STRUCTURE FOR SRD991 / SRD960**

SRD Main Menu

Menu	Factory configuration	Description
<b>1 Mounting</b>		
1.1 Stroke left	✓	Linear actuator, left-hand or direct mounting
1.2 Stroke right		Linear actuator, right-hand mounting
1.3 Rot cclockw		Rotary actuator, opening counter-clockwise
1.4 Rot clockw		Rotary actuator, opening clockwise
1.5 Linear Pot.		For Top Mounting (only for SRD991)
<b>2 Autostart</b>		
2.1 Endpoints		Adaptation of the mechanical stops only
2.2 Standard		Autostart recommended for standard application
2.3 Enhanced		Enh. Autostart. Optimized control behaviour compared to Standard Autostart
2.4 Smooth Resp.		Enh. Autostart. Damped control behaviour for e.g. smaller actuators
2.5 Fast Resp.		Enh. Autostart. Undamped control behaviour for e.g. larger actuators
<b>3 Valve Action</b>		
3.1 SRD		
3.1.1 Direct	✓	Valve opens with increasing setpoint value
3.1.2 Reverse		Valve closes with increasing setpoint value
3.2 Feedback		
3.2.1 Direct	✓	Increasing Current with increasing valve position
3.2.2 Reverse		Decreasing Current with increasing valve position
3.3 Accessories		
3.3.1 None		No accessories mounted
3.3.2 Booster		Booster mounted
<b>4 Character</b>		
4.1 Linear	✓	Linear characteristic
4.2 Eq Perc 1:50		Equal percentage characteristic 1:50
4.3 Quick open		Inverse equal percentage characteristic 1:50 (quick opening)
4.4 Customer		Custom characteristic (Configuration via DTM)
<b>5 Limits/alarms</b>		
<i>(Not locally available with LED versions of communication FF and Profibus)</i>		
5.1 Lower limit	0 %	Closing limit is set to input value
5.2 Cutoff low	1 %	0%-tight sealing point is set to input value
5.3 Cutoff high	100 %	100%-tight sealing point is set to input value
5.4 Upper limit	100 %	Opening limit is set to input value
5.5 Splitr 0 %	4 mA	Split range 0 %: input value corresponds to 0 %
5.6 Splitr 100 %	20 mA	Split range 100 %: input value corresponds to 100 %
5.7 Lower Alarm	-10 %	Lower position alarm on output 1 is set to input value
5.8 Upper Alarm	110 %	Upper position alarm on output 2 is set to input value
5.9 Valve 0 %	4 mA	Configuration of rated-stroke of 0 % at 4 mA
5.10 Valve 100 %	20 mA	Configuration of rated-stroke of 100 % at 20 mA
5.11 Valve corr.		Tuning of position for mounting adaption
5.12 Stroke	x° / 20 mm	Configuration of nominal travel
5.13 Units	SI	Configuration of temperature and pressure unit SI or Anglo US
<b>6 Parameters</b>		
6.1 Gain closing	15	P: Proportional gain for 'close valve'
6.2 Gain opening	2	P: Proportional gain for 'open valve'
6.3 Res time cl	7.5	I: Integration time for 'close valve'
6.4 Res time op	2.7	I: Integration time for 'open valve'
6.5 Rate time cl	0.0	D: Derivative time for 'close valve'
6.6 Rate time op	0.0	D: Derivative time for 'open valve'
6.7 Trav time cl	0.35	Positioning time for 'close valve'
6.8 Trav time op	0.35	Positioning time for 'open valve'
6.9 Control gap	0.1	Permitted dead band for control difference
6.10 Fine tuning		Fine tuning of control for booster applications

7 Output		Manual setting of IP Module for testing of pneumatic output
8 Setpoint		<i>Manual setting of valve position</i>
8.1 12.5 % Steps		Setpoint changes of 12.5 % steps by using push buttons Up or Down
8.2 1 % Steps		Setpoint changes of 1 % steps by using push buttons Up or Down
8.3 0.1 % Steps		Setpoint changes of 0.1 % steps by using push buttons Up or Down
8.4 Do PST		Start the Partial Stroke Test
9 Workbench		
9.1 Reset Config		Resetting of configuration to setting "ex factory"
9.2 Calib. 4 mA		Calibrate input current to 4 mA
9.3 Calib. 20 mA		Calibrate input current to 20 mA
9.4 Calib. -45°		Calibrate position measuring value to -45°
9.5 Calib. +45°		Calibrate position measuring value to +45°
9.6 Reset all 1		Resetting of configuration and Calibration (!) to "ex factory" setting for <b>single-acting</b> output
9.7 Reset all 2		Resetting of configuration and Calibration (!) to "ex factory" setting for <b>double-acting</b> output
9.8 Go Online		Setting position into mode Online (Service function only)
9.9 Menu Lang		Language on LCD:
9.9.1 English	✓	Standard English
9.9.2 Deutsch		Standard German
9.9.3 Français		Preselected / freely definable
9.10 LCD orient		LCD Orientation:
9.10.1 Normal	✓	Normal orientation of writing on LCD
9.10.2 Flipped		Reverse orientation of writing on LCD
10 Profibus PA - Bus Address		<i>Profibus only.</i>
10.1 Address LSB		Ratio from Dec. 0 / Hex 00 to Dec. 15 / Hex 0F
10.2 Address MSB		Ratio from Dec. 0 / Hex 00 to Dec. 112 / Hex 70
10.3 Address	126	Display of Bus Address from Dec. 1 to 127 (Hex 00 to 7F)
10 FOUNDATION Fieldbus H1		<i>FF only.</i>
10.1 Simulate		
Disabled	✓	Simulate disabled
Enabled		Simulate enabled
10.2 Profile		
Link Master		Link Master active
Basic field dev	✓	Link Master de-activated
10.3 Address	248	Bus Address, change by using push buttons Up or Down

**Additional Parameters**

The following parameters are accessible via communication only:

Parameter	ex factory
Control difference limit value	5 %
Control difference response time	1 min
Sealing hysteresis	0.5 %
Failsafe-Aktion	OFF
Power-up action	IN SERVICE
Parameter write protection	OFF
Alarm limit for total strokes	90 Mio.
Alarm limit for total cycles	90 Mio.
Dead band for valve cycles	1 %
Set value source: Model Code xFxx	digital
Set value source: all others	analog
Upper pre-alarm	100 %
Lower pre-alarm	0 %
Hysteresis for position alarms	0.5 %

Complete parameter list see FDT/DTM Software.

### 8.3 Configuration of 0 and 100% Linear actuators

Configuration requested					
MENU 1: "Mounting"				MENU 3: "Valve Action"	
1.1	1.2	1.3	1.4	3.1	3.2

Valid for single and double acting

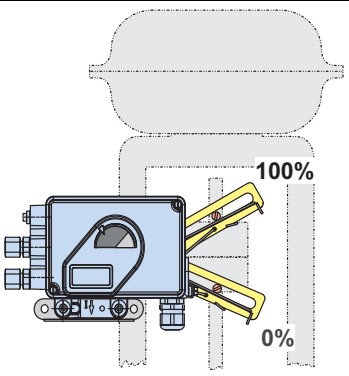
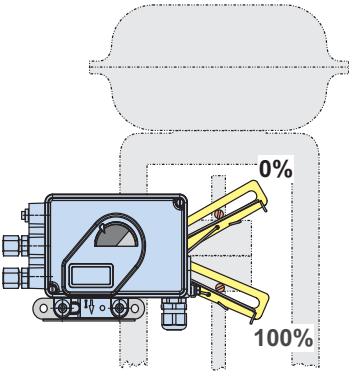
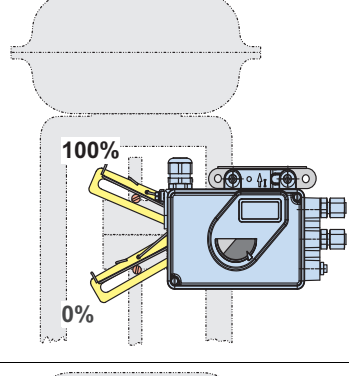
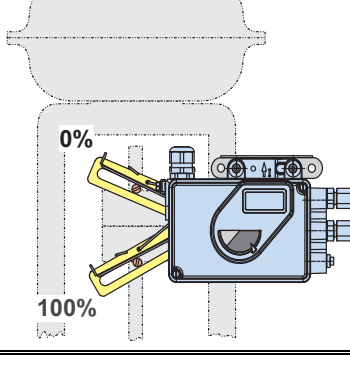
Configuration of 0 and 100%	Input Signal Range	Linear Left	Linear Right	Rot cclockw	Rot clockwise	Direct	Reverse
	4 mA = 0% 20 mA = 100%	✓				✓	
	4 mA = 100% 20 mA = 0%	✓					✓
	4 mA = 0% 20 mA = 100%		✓			✓	
	4 mA = 100% 20 mA = 0%		✓				✓
	4 mA = 0% 20 mA = 100%		✓			✓	
	4 mA = 100% 20 mA = 0%		✓				✓
	4 mA = 0% 20 mA = 100%	✓				✓	
	4 mA = 100% 20 mA = 0%	✓					✓

**Configuration of 0 and 100% (continued)**  
**Rotary actuators**

Configuration requested					
MENU 1: "Mounting"				MENU 3: "Valve Action"	
1.1	1.2	1.3	1.4	3.1	3.2

Valid for single and double acting

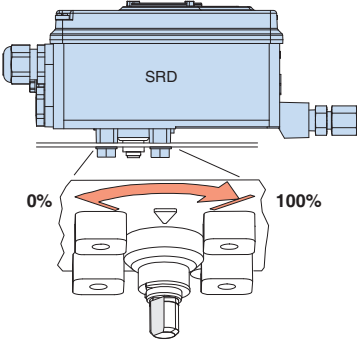
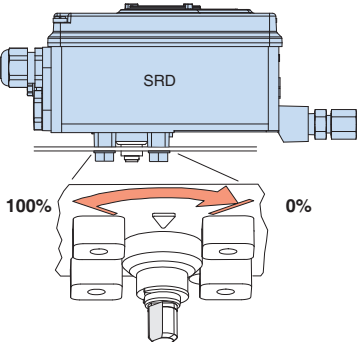
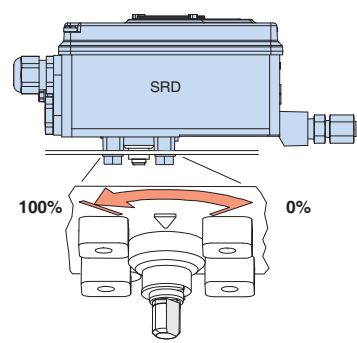
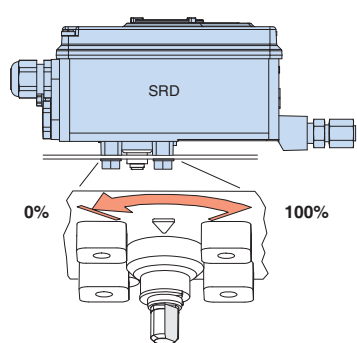
Configuration of 0 and 100%	Request Action	Linear Left	Linear Right	Rot cclockw	Rot clockwise	Direct	Reverse
	4 mA = 0% 20 mA = 100%			✓		✓	
	4 mA = 100% 20 mA = 0%			✓			✓
	4 mA = 0% 20 mA = 100%				✓	✓	
	4 mA = 100% 20 mA = 0%				✓		✓
	4 mA = 0% 20 mA = 100%				✓	✓	
	4 mA = 100% 20 mA = 0%				✓		✓
	4 mA = 0% 20 mA = 100%			✓		✓	
	4 mA = 100% 20 mA = 0%			✓			✓

### 8.4 Description of menus

Because of optimized local operation, for configuration neither PC nor control system is required.

In case operation via local keys is not possible check if write protection is set. Change via FDT/DTM software.

#### Menu 1: Actuator system, Mounting side

SRD Main Menue
<b>1 Mounting</b>
2 Autostart
3 Valve Action

Confirm with keys UP+DOWN

1 Mounting
<b>1.1 Stroke left</b>
1.2 Stroke right
1.3 Rot cclockw

(Further with UP key:)

1 Mounting
1.1 Stroke left
<b>1.2 Stroke right</b>
1.3 Rot cclockw

1 Mounting
1.1 Stroke left
1.2 Stroke right
<b>1.3 Rot cclockw</b>

1 Mounting
1.2 Stroke right
1.3 Rot cclockw
<b>1.4 Rot clockw</b>

### WARNING

To avoid any personal injury or property damage from sudden or fast movement, during configuration:

**Do not put your finger or other part at any time inside the valve or in any moving part of the actuator. Do not put your finger or other part at any time in the feedback lever mechanism. Do not touch the rear part of the positioner at any time.**

M	1	2	3	4	
1/2	1/2	-	-	-	M and LED 1 flash

For an optimal actuator adaptation the SRD has to be configured whether it is a rotary or a linear actuator.

The positioner of the **rotary** actuator can work directly with the linear position sensor value. In case of a **stroke** actuator an error  $\tan(\alpha)$  arises due to the angle of the resulting in 1% non-linearity at travel of 30°. The SRD is able to correct the travel via the tan function and thus avoid bigger linearity errors.

The rotation direction of the adapter shaft for the tap changes depending on the mounting side of the stroke actuator. "Valve closed" in one case means "Valve open" in another one.

There are rotary actuator types opening in the counter clockwise direction and others opening in the clockwise direction. This also has to be signaled to the SRD so that 0% "Valve closed" and 100% "Valve open" are correctly assigned.

-	1	-	-	-	LED 1 lights up
---	---	---	---	---	-----------------

For stroke actuators mounted at left of the spindle resp. directly mounted.

-	-	1	-	-	LED 2 lights up
---	---	---	---	---	-----------------

For stroke actuators mounted at right of the spindle.

-	-	-	1	-	LED 3 lights up
---	---	---	---	---	-----------------

For rotary actuators opening the valve during counter clockwise (left) rotation.

-	-	-	-	1	LED 4 lights up
---	---	---	---	---	-----------------

For rotary actuators opening the valve during clockwise (right) rotation.

**Menu 2: Autostart**

SRD Main Menu
1 Mounting
<b>2 Autostart</b>
3 Valve Action

2 Autostart
2.1 Endpoints
<b>2.2 Standard</b>
2.3 Enhanced

2 Autostart
2.3 Enhanced
2.4 Smooth resp
<b>2.5 Fast resp.</b>

2 Autostart
SRD991 Vers.xx
Get end points

2 Autostart
SRD991 Vers.xx
Get motor gain

2 Autostart
SRD991 Vers.xx
Control params

2 Autostart
SRD991 Vers.xx
Get valve speed

M	1	2	3	4	
½	-	½	-	-	M and LED 2 flash

Selection between different Autostart modes (change with key UP or DOWN):

**Autostart:**

To automatically adapt the positioner to the valve. Geometric data of the actuator is determined and optimally assigned to control parameters. If the "Standard" Autostart does not result in stable regulation, another Autostart mode - depending upon actuator - should be selected. At **initial start-up**, an Autostart should always be performed.

**Attention:** Autostart overwrites previous control parameters!

**2.2 Ready for "Standard" Autostart:**

-	1	-	-	1	LED 1 and LED 4 lights up
---	---	---	---	---	---------------------------

With key UP or DOWN to other Autostart modes:

**2.1 Ready for "End points" Autostart:**

Serves for automatic adjustment of the SRD to the mechanical end points.

-	-	1	1	-	LED 2 and LED 3 lights up
---	---	---	---	---	---------------------------

**2.3 Ready for "Enhanced" Autostart**

To the optimization of the controller parameters in relation to standard mode:

-	-	1	-	1	LED 2 and LED 4 lights up
---	---	---	---	---	---------------------------

**2.4 Ready for "Smooth response" Autostart:**

Extended, damped controller parameters for e.g. smaller drives

-	1	-	1	-	LED 1 and LED 3 lights up
---	---	---	---	---	---------------------------

**2.5 Ready for "Fast response" Autostart:**

Extended, undamped controller parameters for e.g. larger drives

-	1	1	-	-	LED 1 and LED 2 lights up
---	---	---	---	---	---------------------------

**⚠ WARNING**

**To avoid any personal injury or property damage from sudden or fast movement, during Autostart:**

**Do not put your finger or other part at any time inside the valve or in any moving part of the actuator. Do not put your finger or other part at any time in the feedback lever mechanism. Do not touch the rear part of the positioner at any time.**

After selection and start (by pressing the UP+DOWN keys) the function taking several minutes can be followed at LCD or the green LEDs. Duration on a valve position can take some time depending on actuator volume, air supply, pressure, etc.

-	1	-	-	-	LED 1 lights up
---	---	---	---	---	-----------------

Moving direction, mechanical starting and ending positions are determined by one or several passages of valve position range.

-	-	1	-	-	LED 2 lights up
---	---	---	---	---	-----------------

Ramps are entered and control system parameter is determined (ratio position/valve size).

-	-	-	1	-	LED 3 lights up
---	---	---	---	---	-----------------

Jumps are entered for determination of control parameters.

D	-	-	-	1	LED 4 lights up
---	---	---	---	---	-----------------

Determination of positioning speeds.

-	-	-	-	-	All LEDs are off
---	---	---	---	---	------------------

Determined values are saved; previous values are superscribed. The SRD is IN SERVICE again with the detected new parameters.

**Menu 3: Mode of Action of SRD  
(and additional Position Feedback)**

SRD Main Menu
1 Mounting
<b>2 Autostart</b>
3 Valve Action

3 Valve Action
<b>3.1 SRD</b>
3.2 Feedback
3.3 Accessories

3.1 SRD
<b>3.1.1 Direct</b>
3.1.2 Reverse

3 Valve Action
3.1 SRD
<b>3.2 Feedback</b>
3.3 Accessories

3 Valve Action
3.1 SRD
3.2 Feedback
<b>3.3 Accessories</b>

**Menu 4: Characteristic of setpoint**

SRD Main Menu
2 Autostart
3 Valve Action
<b>4 Character</b>

4 Character
<b>4.1 Linear</b>
4.2 Eq Perc 1:50
4.3 Quick open

4 Character
4.1 Linear
<b>4.2 Eq Perc 1:50</b>
4.3 Quick open

M	1	2	3	4
1/2	-	-	1/2	-
M and LED 3 flash				

Function of the positioner is set at:  
It will set the mode of action of the positioner and the optionally present feedback. Without the card "position feedback", the menu item "Feedback" is not displayed.

**3.1 Select "SRD":**

1/4	3/4	-	-	-
M short flash, LED 1 long flash				

-	1	-	-	-
LED 1 lights up				

3.1.1 "Normal" if increasing input signal is to initiate increasing output signal.

-	-	-	-	1
LED 4 lights up				

3.1.2 "Reverse" if increasing input signal is to initiate decreasing output signal.

**3.2 Select "Feedback": (if present)**

1/4	-	3/4	-	-
M short flash, LED 2 long flash				

-	1	-	-	-
LED 1 lights up				

3.2.1 "Normal" for increasing current with increasing valve position.

-	-	-	-	1
LED 4 lights up				

3.2.2 "Reverse" for decreasing current with increasing valve position.

**3.3 Select "Accessories"**  
3.3.2 Select "Booster" if Booster is present, otherwise 3.3.1 "None".

M	1	2	3	4
1/2	-	-	-	1/2
M and LED 4 flash				

A relationship between the input signal and valve position is set.

-	1	-	-	-
LED 1 lights up				

4.1 "Linear". See Fig. 4.1

-	-	1	-	-
LED 2 lights up				

4.2 "Equal percentage": Results in an equal percentage characteristic line with a position ratio of 1:50 for a valve of linear characteristic. See Fig. 4.2

-	-	-	1	-
LED 3 lights up				

4.3 "Quick open" (Inverse equal percentage): Results in an inversely equal percentage characteristic line with a position ratio of 50:1 for a valve of linear characteristic. See Fig. 4.3

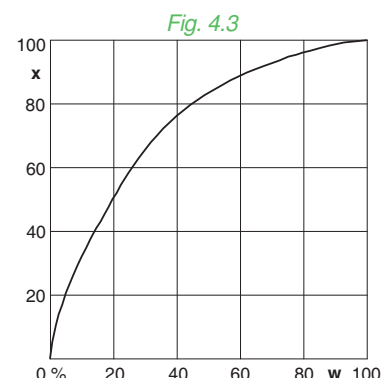
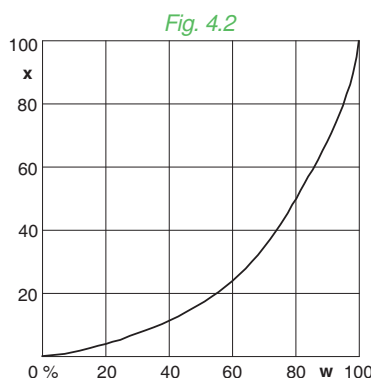
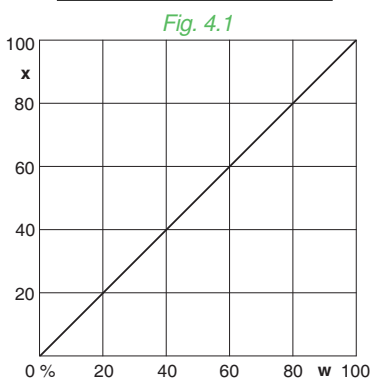



- 4 Valve Char.
- 4.2 Eq Perc 1:50
- 4.3 Quick open
- 4.4 Custom

- - - - 1 LED 4 lights up

"User defined characteristic". A characteristic line entered via communication (not via local keys) with 2 to 22 supporting points is activated. A linear characteristic is factory set.

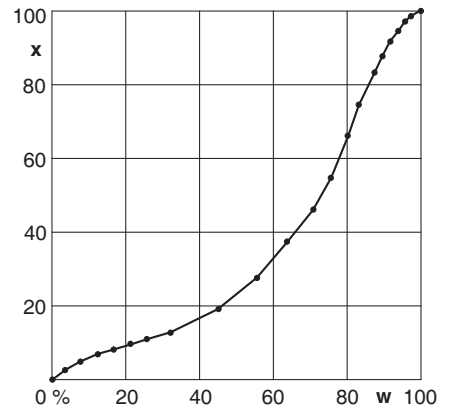

**Menu 5: Limit and Alarms of valve**

- SRD Main Menu
- 3 Valve Action
- 4 Character
- 5 Limits/Alarms

**Note:**

With versions with LCD, the values can be adjusted stepwise locally in "clear text" with keys UP or DOWN.  
 With versions with LED and HART or "without communication", the corresponding current of the valve is rated via analog output and entered with keys UP+DOWN.  
 With versions LED and fieldbus, the values can be entered only via communication.  
 With versions with communication, the values can be configured also with corresponding software.

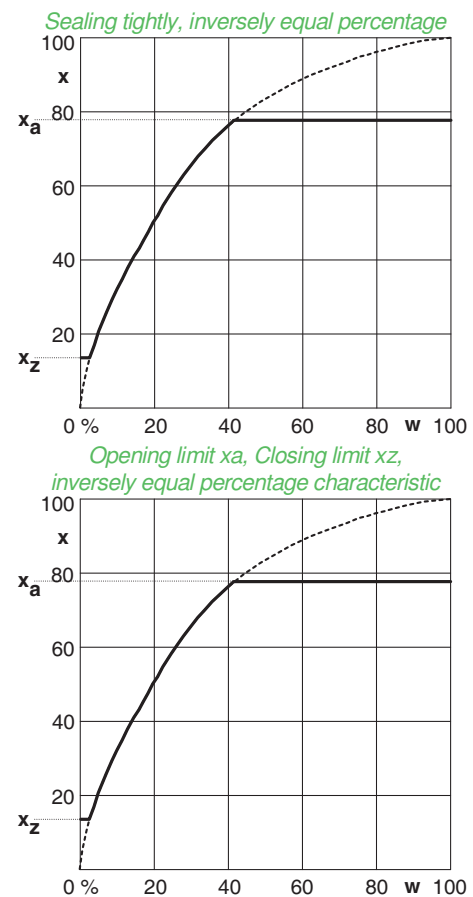
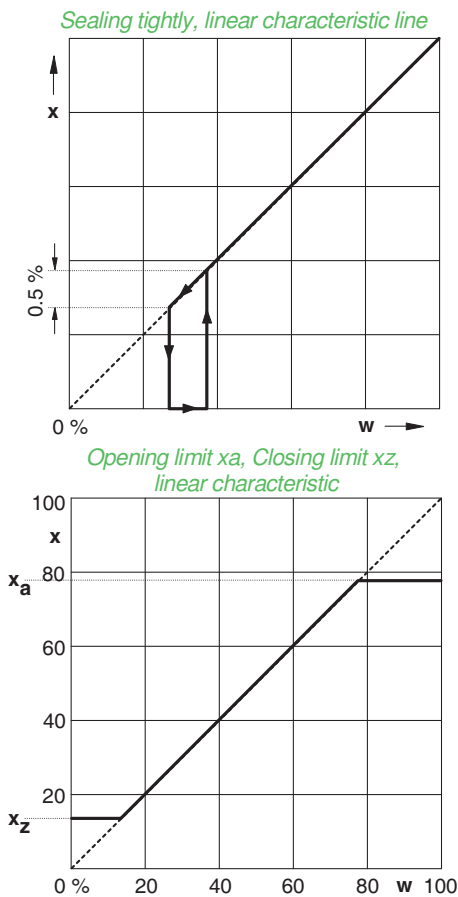

5	Limits/Alarms
5.1	Lower limit
5.2	Cutoff low
5.3	Cutoff high

5.1	Lower Limit
2.0	%

### 5.1 Setting Lower limit ("closing limit")

-	1	-	-	-	LED 1 lights up
---	---	---	---	---	-----------------

The positioner provides that IN SERVICE the valve position does not close any further than defined by the closing limit. If the set point value is lower than this limit, message 12 (see page 50) is produced.

By pressing of UP or DOWN keys, the value is adjusted and confirmed with keys UP+DOWN. The keys have auto repeat: By pressing and holding of a key UP or DOWN, the value is counted upward, after some time in larger steps.

*Example: Lower limit is set to 2 %.*

5	Limits/Alarms
5.1	Lower limit
5.2	Cutoff low
5.3	Cutoff high

5.2	Cutoff low
3.0	%

### 5.2 Setting Cutoff low ("0% seal-tight point")

-	-	1	-	-	LED 2 lights up
---	---	---	---	---	-----------------

If a 0% seal-tight point is given, in case the set point is deviated lower (e.g. 3 %), the SRD provides the pneumatic output to press the valve into its seat with full force in order to tightly seal valve.

As soon as the command value is 1%\* higher than this seal-tight value, the position again follows the command value.

\* This is the "Seal-tight hysteresis" factory set at 1 %. The value may be changed via communication.

5	Limits/Alarms
5.1	Lower limit
5.2	Cutoff low
5.3	Cutoff high

5.3	Cutoff high
97.0	%

### 5.3 Setting Cutoff high ("100% seal-tight point")

-	-	-	1	-	LED 3 lights up
---	---	---	---	---	-----------------

If a 100% seal-tight point is pre-set and in case a certain set value is exceeded (e.g. 97 %), the SRD provides that the pneumatic output presses the valve 100% into its seat with full force.

This function makes sense for 3-way valves.

Also both seal-tight points can be used in order to tightly close the respective shut-off path during partial operation.

By pressing of UP or DOWN keys, the value is adjusted and confirmed with keys UP+DOWN. The keys have Autorepeat: By pressing and holding of a key UP or DOWN, the value is counted upward, after some time in larger steps.

*Example: Cutoff high is set to 97 %.*

5	Limits/Alarms
5.2	Cutoff low
5.3	Cutoff high
5.4	Upper limit

### 5.4 Setting Upper limit ("opening limit")

-	-	-	-	1	LED 4 lights up
---	---	---	---	---	-----------------

The SRD provides that IN SERVICE the valve position does not open any further than defined by the opening limit. If the set value is exceeded, message 13 (see page 50) is produced.

#### Definitions

**Stroke, stroke range** of the membrane actuator is defined for rotary actuator as **angle, angle range**.

**0 % position** is the mechanical impact at actually closed valve (caution if using hand wheel and mechanically adjustable stroke limitation!)

**100 % position** is the mechanical impact at actually open valve.

**Closing limit** is a lower limit set via software. In normal operation the valve will not close more than set here. Attention: In the event of failure of the auxiliary energy no controlling is possible, therefore the springs in the actuator will move the valve into safety position (for single-acting actuator).

**Opening limit** is a upper limit set via software. In normal operation the valve will not close more than set here. Attention: In the event of failure of the auxiliary energy no controlling is possible, therefore the springs in the actuator will move the valve into safety position (for single-acting actuator).

**Normal operation** (= IN SERVICE) means that the position is controlled to the 4 to 20 mA input signal.

**Split Range**

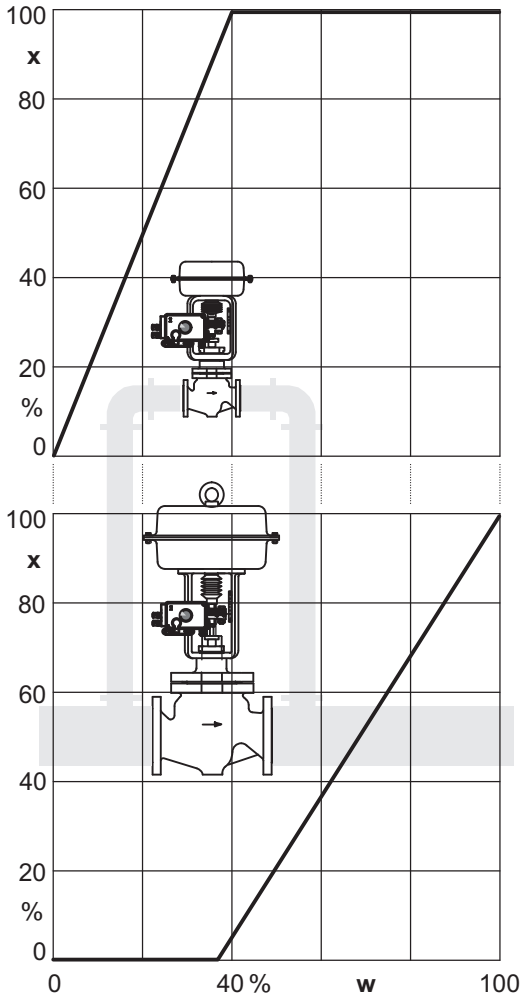

**Split-Range, PV\_Scale Splitting**

Split Range is useful if an additional control range is demanded which cannot be covered by one valve only. A valve of smaller nominal size can be applied overtaking the smallest quantities; a parallel mounted valve of bigger nominal size takes on the larger quantities.

With conventional positioners, this function is realized through serial connection of the instruments and allocation of individual regulating ranges (see illustration). With SRD with analog set point value (version HART or “without communication”), this can be adjusted with menus 5.5 and 5.6.

The other versions of the SRD receive the set value via digital means; the input data signal cannot be splitted. The function can be realized either in the primary control system, in which set point values are calculated for each valve, or via the variables PV\_SCALE. With PV\_Scale the digital input set point value can be assigned to the valve span.

*Example: At low current, only the smaller valve positions; from approx. 40 % the large valve is added*

**SRD991 with HART or “Without Communication”**

(With the other versions of the SRD, these menus cannot be selected.)

```

5 Limits/Alarms
5.4 Upper limit
5.5 Splitr 0 %
5.6 Splitr 100 %
    
```

**5.5 Split Range 0 %**

-	1	-	1	-	LED1 and LED 3 lights up
---	---	---	---	---	--------------------------

LED: The value that was adjusted e.g. with a loop calibrator at the input of the SRD, is entered with confirmation of keys UP+DOWN as 0 % value.  
LCD: By pressing of keys UP or DOWN the value is adjusted and confirmed with keys UP+DOWN.

```

5 Limits/Alarms
5.4 Upper limit
5.5 Splitr 0 %
5.6 Splitr 100 %
    
```

**5.6 Split Range 100 %**

-	-	-	1	1	LED 3 and LED 4 lights up
---	---	---	---	---	---------------------------

LED: The value that was adjusted e.g. with a loop calibrator at the input of the SRD, is entered with confirmation of keys UP+DOWN as 0 % value.  
LCD: By pressing of keys UP or DOWN the value is adjusted and confirmed with keys UP+DOWN.

```

5.6 Splitr 100 %

10.4 mA
    
```

The keys have Auto repeat: By pressing and holding of a key UP or DOWN, the value is counted upward, after some time in larger steps.

*Example: Input current of 10.4 mA has to correspond to a valve position of 100 %.*

5	Limits/Alarms
5.6	Splitr 100 %
5.7	Lower Alarm
5.8	Upper Alarm

5	Limits/Alarms
5.6	Splitr 100 %
5.7	Lower Alarm
5.8	Upper Alarm

5.8	Upper Alarm
91.3 %	

### 5.7 Setting Lower Alarm

-	1	1	-	-	LED 1 and LED 2 lights up
---	---	---	---	---	---------------------------

When falling below the set value underneath the entered alarm limit, an alarm is activated. Message 12 (see page 50) is generated.

To switch off the alarm setting, enter the value -10%.

### 5.8 Setting Upper Alarm

-	-	1	-	1	LED 2 and LED 4 lights up
---	---	---	---	---	---------------------------

When surpassing the set value above the entered alarm limit, an alarm is activated. Message 13 is generated.

To switch off the alarm setting, enter the value +110%.

By pressing of keys UP or DOWN, the value is adjusted and with keys UP+DOWN confirmed. The keys have auto repeat: By pressing and holding of a key UP or DOWN, the value is counted upward, after some time in larger steps.

*Example: Upper Alarm set to 91.3 %.*

### 5.9 Valve Limits (Not with versions FF / PB with LED display).

At Autostart, the SRD determines the real limits of the actuator (which generally are a little larger then specified on the specification sheet).

An actuator with 30 mm stroke could display a real stroke of 33 mm. In order to produce a precise relationship between the input signal and the stroke, the tolerances of the actuator can be compensated with menus 5.9 and 5.10. At unchanged 0 %, the actuator could be moved until exactly 30 mm are reached. Through execution of function 5.10, the current position can be declared as 100 % and at a set point value of 50 %, the actuator will run on exactly 15 mm.

For new configuration of the strokes at 0% or 100%, the valve must be run in the corresponding position and then must be confirmed.

5	Limits/Alarms
5.9	Valve 0 %
5.10	Valve 100 %
5.11	Valve corr.

5	Limits/Alarms
5.9	Valve 0 %
5.10	Valve 100 %
5.11	Valve corr.

5.10	Valve 100 %
98.4 %	
Confirm	

### 5.9 Setting Valve 0 %

-	1	1	-	1	LED 1, LED 2 and LED 4 lights up
---	---	---	---	---	----------------------------------

The actual position of the actuator is declared as 0 %.

### 5.10 Setting Valve 100 %

-	-	1	1	1	LED 2, LED 3 and LED 4 lights up
---	---	---	---	---	----------------------------------

The actual position of the actuator is declared as 100 %.

By pressing of keys UP or DOWN, the value is adjusted and with keys UP+DOWN confirmed. The keys have auto repeat: By pressing and holding of a key UP or DOWN, the value is counted upward, after some time in larger steps.

*Example: The actual valve position 98.4 % is to be counted as 100 %.*

```

5 Limits/Alarms
5.11 Valve corr.
5.12 Stroke
5.13 Units

```

### 5.11 Valve correction

Because of inaccuracies at mounting, it may be possible that at input value 50 % (= 12 mA) the stroke valve is not exactly at half of stroke, regarding scale at valve. To correct this, apply 12 mA and select this function. Move valve position to half of stroke by pressing of UP or DOWN keys, and confirm. End points of stroke and  $\tan(\alpha)$  values are automatically adapted and makes positioning even more precisely.

```

5 Limits/Alarms
5.11 Valve corr.
5.12 Stroke
5.13 Units

```

### 5.12 Setting Stroke with stroke actuators (only with LCD)

The SRD measures with its feedback lever always only an angle and by means of its tangent function, a linear stroke of 0 to 100 % is calculated there from. In order to indicate as well a real stroke in mm, the full stroke at 100 % can be entered in this menu. The LCD display will then indicate the actual position in mm (or inch).

By pressing of keys UP or DOWN, the value is adjusted and with keys UP+DOWN confirmed. The keys have auto repeat: By pressing and holding of a key UP or DOWN, the value is counted upward, after some time in larger steps.

```

5.12 Stroke
      30.0 mm
      1 in = 25.4 mm

```

*Example: Stroke range of valve is to be 30 mm.*

```

5 Limits/Alarms
5.11 Valve corr.
5.12 Stroke
5.13 Units

```

### 5.13 Indication of Units (only with LCD)

Selection of indication as SI units, or Anglo US (°C / °F) (mm / inch)

**Menu 6: Parameter for Position controller**

Along with the determination of the actuator geometry and control parameters the suitable setting parameters for the position controller are determined via function AUTOSTART in Menu 2. Assessment of a control behavior generally is very subjective. Partially a quick response is requested without consideration of the overshoot width, partially a very smooth swinging is requested with minor overshoot.

We basically recommend first to perform the execution of the automatic setting via AUTOSTART in Menu 2 in order to achieve a stable control behavior. Corrections may then be made from the determined values. In rare cases AUTOSTART cannot find the optimal setting for the respective application. See "Remarks for controller optimization" following table 4.

SRD Main Menu
4 Valve Char.
5 Limits/Alarms
6 Parameters

6 Parameters
6.1 Gain closing
6.2 Gain opening
6.3 Res time cl
6.4 Res time op
6.5 Rate time cl
6.6 Rate time op
6.7 Trav time cl
6.8 Trav time op
6.9 Control gap
6.10 Fine tuning

M	1	2	3	4	
1/2	1/2	-	1/2	-	M, LED 1, and LED 3 flash

Several control parameters are combined in Menu 6 each availing of a sub-menu. The values may be adjusted in each of these and pressing of UP+DOWN be entered in the position controller as constant. Controller type is a PID controller.

Parameter-Designation	Valve is opening	Valve is closing	Unit
Proportionate amplification Kp	Kp↑	Kp↓	-
Integration time constant	Tn↑	Tn↓	sec
Derivate time constant	Tv↑	Tv↓	sec
Positioning time	T63↑	T63↓	sec
Dead band for control diff.	GAP	GAP	% of span

6.9 The dead band prevents (at the expense of accuracy) that the valve in the controlled condition constantly moves around the set point. This reduces harm to the mechanical parts of the actuator and, in particular, the valve packing.

6.10 With boosters: If unsatisfactory behavior occurs with small set point jumps, the value can be increased successively from 0.0 to 0.1 or 0.2.

**Selection of sub-menus:**

M	1	2	3	4	
1/4	-	3/4	-	-	M, LED 2 flash: Kp
1/4	3/4	3/4	-	-	M, LED 1 and LED 2 flash: Kp
1/4	-	-	3/4	-	M, LED 3 flash: Tn
1/4	3/4	-	3/4	-	M, LED 1 and LED 3 flash: Tn
1/4	-	-	-	3/4	M, LED 4 flash: Tv
1/4	3/4	-	-	3/4	M, LED 1 and LED 4 flash: Tv
1/4	-	3/4	3/4	-	M, LED 2 and LED 3 flash: T63
1/4	3/4	3/4	3/4	-	M, LED 1, LED 2 and LED 3 flash: T63
1/4	-	3/4	-	3/4	M, LED 2 and LED 4 flash: GAP
1/4	-	3/4	3/4	3/4	M, LED 2, LED 3, LED 4 flash: Fine tuning

Following selection of the sub-menu the codes for the parameter values can be adjusted and saved by pressing UP+DOWN.

## Remarks to Controller Tuning

If AUTOSTART does not find the optimum setting the following may be the result:

- A) Slow response to set point, long positioning time or long neutral time
- B) Continuous oscillation following set point jump
- C) Wide and high overshoot

For the assessment of the control 12.5 % jumps in both directions may be performed in Menu 8. The valve dynamics may be observed at LCD or the mechanical indicator.

Prior to changing parameters for valve dynamics a number of items are to be checked, see below. The pneumatic output can be operated directly without controller via Menu 7 and the valve movement may be assessed.

In case of behavior A) check:

1. Is the Proportionate gain  $K_p \uparrow$  (Menu 6.1) or  $K_p \downarrow$  (Menu 6.2) too small?

Remedy: Increase parameters.

2. Is the air pressure high enough to possibly overcome the actuator spring force and friction?  
Remedy: Increase air pressure.
3. Is the actuator volume high, possibly requiring an increased air capacity for fast valve movement?  
Remedy: Attach booster, see accessories, or spool valve option.
4. Was AUTOSTART performed in Menu 2 and did messages 8 resp. 9 occur (messages, see table page 50)?  
Remedy: "AUTOSTART" in Menu 2 resp. observe information in table, page 50.
5. Has the parameter for the positioning time been set at a value too high?  
Remedy: decrease both parameters "T63" in Menu 6.7 and 6.8
6. Is valve packing too tight resulting in a very high friction?
7. Is the supply air filter blocked?  
Remedy - see page 46.
8. Has the supply air been contaminated by small oil drops, particulate or are pneumatic parts possibly blocked?  
Remedy: exchange pneumatic parts; possibly use a suitable air supply station.

Behaviors B) and C) check:

1. Is the air capacity possibly too high, e.g. through spool valve or booster?  
Remedy: Work, if necessary, without booster or use version without spool valve.
2. Has the air supply pressure been set too high?  
Remedy: reduce pressure, install pressure reducer.

Changing valve dynamics during behavior A):

If valve has a high friction (for example, often the case in small rotary actuators due to low air supply pressure or due to a valve seat packing which is too tight) then the valve position gets stuck after a set point jump and possibly is re-controlled via the resetting time  $T_n$ , possibly after quite some time has elapsed.

Basically, the following is possible:

- a) to accept a remaining deviation
- b) to accept some response procedures (such as remaining in over-response for a short time, and remaining below set point and trailing).

When deciding a), " $T_n$ " should become ineffective, table value (15). Compensating " $P(kp)$ " should be increased until the set point jumps reach the set point within a short period of time and without significant over-response (adapt to both movement directions).

When deciding b) start as in a) above. Thereafter " $T_n$ " is re-switched and decreased until the set point deviation has been re-controlled within a short period of time and without long after-response (adapt in both movement directions).

It is recommended to maintain the  $T_n$ 's for both directions about the same.

If a post oscillation occurs after a set point jump, " $T_n$ " is selected too small, possibly " $P(kp)$ " was selected too large.

The positioning time " $T63$ ", also called valve damping, does not have an effect during AUTOSTART in Menu 2, however, set point jumps in Menu 8 reach the position controller in a damped condition which then is not easily stimulated to oscillation. This behavior is also true for the set point input.

This enables setting the controller to higher " $P(kp)$ " values without producing oscillations in the process. On one side this helps the position control to level disturbances due to friction, changes in load or air supply pressure changes faster. On the other hand it helps the superimposed valve control circuit that neutral times in the valve control route do not have such a big effect (stability in valve control circuit).

Changing valve dynamics during behavior B):

Increase " $T_n$ " for both movement directions, possibly turn off and proceed as described in behavior A) alternative b).

**WARNING** To avoid any personal injury or property damage from sudden or fast movement, during use of Menu 7 pneumatic output: **Do not put your finger or other part at any time inside the valve or in any moving part of the actuator. Do not put your finger or other part at any time in the feedback lever mechanism. Do not touch the rear part of the positioner at any time.**

**Menu 7: Pneumatic output**  
(for trouble-shooting)

- SRD Main Menu
- 5 Limits/Alarms
- 6 Parameters
- 7 Output

- 7 Output
- \_\_\_\_\_ ]

etc.

M	1	2	3	4	
½	½	-	-	½	M, LED 1 and LED 4 flash

Serves to check the pneumatic parts of the positioner and the right valve piping by directly applying current to the IP module with the UP and DOWN keys (no control; software limit values such as “stroke limits” or “tight closing” are ignored).

The current of the IP module is increased by about 3% in 32 steps. By measuring the output pressure generally the following characteristic line of the IP module is achieved. The ramp also may be more steep or flat depending on the air supply pressure.

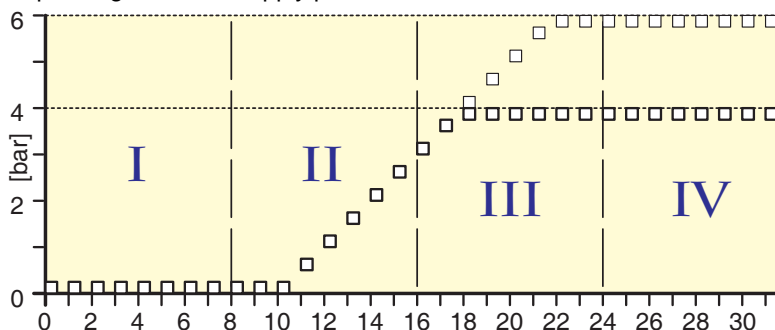

The pneumatic works precisely, if the actuator begins movement in section II and runs latest in section IV into the end position.

If no reaction is shown, check: - does air supply exist? - is plug connected to IP module? If these items are okay, possibly the electronics or a pneumatic part is defective. See also page 47.

After leaving this menu (by pressing the M key or UP+DOWN) the actual set point is automatically restarted.

**WARNING** To avoid any personal injury or property damage from sudden or fast movement, during use of Menu 8 manual setting of valve position: **Do not put your finger or other part at any time inside the valve or in any moving part of the actuator. Do not put your finger or other part at any time in the feedback lever mechanism. Do not touch the rear part of the positioner at any time.**

**Menu 8: Manual setting of valve position**

- SRD Main Menu
- 6 Parameters
- 7 Output
- 8 Setpoint

- 8 Setpoint
- 8.1 12.5% Steps
- 8.2. 1% Steps
- 8.3 0.1 % Steps

- 8 Setpoint
- \_\_\_\_\_ ] 12.5 %
- Pos. 12.5 %

etc.

- 8 Setpoint
- 8.2. 1% Steps
- 8.3 0.1 % Steps
- 8.4 Do PST

M	1	2	3	4	
½	-	½	½	-	M, LED 2, and LED 3 flash

For the purpose of checking the control reaction of the actuator to a set point jump can be observed via the indicator. As far as the device is IN SERVICE the UP/DOWN keys can initiate jumps of 12.5 % (or 1 %, or 0.1 %) each.

The starting value for Menu 8 is always the current set point value.

If the control behavior is to be improved, this can be reached by performing a complete Autostart (see Menu 2) or through manual tuning (see Menu 6).

After leaving this menu the existing set point value at the input is automatically restarted.

This menu point can also be called up under normal operating conditions, by twice pressing of key M.

**8.4 Do PST**

With this function, the Partial Stroke Test is started, with the given parameters by DTM. After the test is passed, back to the menu.

If the PST is not passed, the error message "PST error" appears on LCD.



**Menu 9: Calibration functions** (for workshop)

SRD Main Menu
7 Outoput
8 Setpoint
9 Workbench

9 Workbench
9.1 Reset Config
9.2 Calib 4 mA
9.3 Calib 20 mA

The following calibration functions must only be performed by trained personnel.

SRD991 with HART or "Without Communication"

9 Workbench
9.1 Reset Config
9.2 Calib 4 mA
9.3 Calib 20 mA

9 Workbench
9.1 Reset Config
9.2 Calib 4 mA
9.3 Calib 20 mA

9 Workbench
9.4 Calib -45°
9.5 Calib +45°
9.6 Reset all 1

9 Workbench
9.4 Calib -45°
9.5 Calib +45°
9.6 Reset all 1

M	1	2	3	4	
1/2	-	1/2	-	1/2	M, LED 2, and LED 4 flash

Factory calibrations are carried out with sufficient accuracy and remain unchanged during life time. However, an alignment may become necessary in some cases after servicing hardware components.

**9.1 Reset Configuration to "ex factory" settings**

-	1	-	-	-	LED 1 lights up
---	---	---	---	---	-----------------

It is possible to restore the configuration existing at time of delivery via this function. This may become necessary if it is unclear what had been changed per menu or in the event that a positioner was taken from one actuator and mounted to another actuator.

Following this function the device is turned to condition OUT OF SERVICE. This has to be followed by Autostart for the purpose of adapting the calibration to the actuator and to start IN SERVICE.

The parameters of the factory setting are listed in table Menu Structure (page 27).

The calibration of the input current or position sensor makes sense, if after exchange of the electronic, the valve position is inaccurately displayed.

**Calibration of input current** (Only with SRD with analog set point; does not apply to fieldbus instruments.)

Serves to equalize possible inaccuracies in the complete current loop.

**9.2 Calibration of input current to 4 mA**

-	-	1	-	-	LED 2 lights up
---	---	---	---	---	-----------------

The present input current value is taken over as "4 mA" when pressing keys UP+DOWN.

**9.3 Calibration of input current to 20 mA**

-	1	1	-	-	LED 1 and LED 2 lights up
---	---	---	---	---	---------------------------

The present input current value is taken over as "20 mA" when pressing keys UP+DOWN.

**Calibration of position sensor** (angle calibration)

The angle pertaining to the vertical tap position (arrow mark) is factory calibrated for the position tap. If the position sensor or the electronics board is exchanged the mechanical and electric tolerances have to be aligned through recalibration. See Service Instruction manual.

**9.4 Calibration of position sensor value to -45°**

-	-	-	1	-	LED 3 lights up
---	---	---	---	---	-----------------

The present position value is taken over as angle -45° when pressing keys UP+DOWN.

**9.5 Calibration of position sensor value to +45°**

-	1	-	1	-	LED 1 and LED 3 lights up
---	---	---	---	---	---------------------------

The present position value is taken over as angle +45° when pressing keys UP+DOWN.

9 Workbench
9.6 Reset all 1
9.7 Reset all 2
9.8 Go Online

9 Workbench
9.6 Reset all 1
9.7 Reset all 2°
9.9 Go Online

9 Workbench
9.6 Reset all 1
9.2 Reset all 2
9.8 Go Online

**Resetting of Configuration and Calibration to “ex factory” settings**

For the exchange of the electronic, the device must be configured whether the pneumatic output is single acting or double acting so that the controller shows the correct behavior during the next start-up.

**Caution:** The current calibration for inputs and outputs, the angle calibration and all other calibrations are reset to their factory defined condition!

**9.6 Resetting of Configuration and Calibration to “ex factory” settings – for single acting pneumatic output**

-	-	-	-	1	LED 4 lights up
---	---	---	---	---	-----------------

The factory calibration for single acting pneumatic output is restored when pressing UP+DOWN keys simultaneously.

**9.7 Resetting of Configuration and Calibration to “ex factory” settings – for double acting pneumatic output**

-	1	-	-	1	LED 1 and LED 4 lights up
---	---	---	---	---	---------------------------

The factory calibration for double acting pneumatic output is restored when pressing UP+DOWN keys simultaneously.

**9.8 Go Online without Autostart**

In principle, the first startup runs an Autostart in which the SRD is optimally adapted to the actuator, then the SRD goes online and begins to regulate. This service function sets the SRD directly online, without an Autostart. Use only for test purposes. *Not recommended for regular use.*

**Configuration functions for all versions with LCD**

9 Workbench
9.7 Reset all 2
9.8 Go Online
9.9 Menu Lang

9.9 Menu Lang
9.9.1 English
9.9.2 Deutsch
9.9.3 (Francais)

9 Workbench
9.8 Go Online
9.9 Menu Lang
9.10 LCD Orient

9.10 LCD Orient
9.10.1 Normal
9.10.2 Flipped

9.10.2 Flipped
9.10.1 Normal
9.10 LCD orient

**9.9 Selection of menu language <sup>1)</sup>**

One of three of the programmed languages can be selected (only with version with LCD)

Ex-factory the active language is always English. Changing to one of the other two languages can also take place during operation.

The third menu language can be selected and was already programmed in the factory according to customer order. If a different third menu language is desired, then the language file can be downloaded from our website.

Thereafter download the file from the PC via FDT/DTM-Software onto the SRD. See also references on the internet page.

**9.10 LCD Orientation <sup>1)</sup>**

Display normal or turned by 180°

1) The menus 9.8 and 9.9 appear automatically at initial start-up, i.e. if the SRD is connected the first time to the electrical supply.

**SRD991 with PROFIBUS PA:**  
**Menu 10: Bus Address**

SRD Main Menu
8 Setpoint
9 Workbench
<b>10 Bus address</b>

10 Bus address
<b>10.1 Address LSB</b>
10.2 Address MSB
10.3 Address

10 Bus address
10.1 Address LSB
<b>10.2 Address MSB</b>
10.3 Address

10.2 Address MSB
Dec: 48 Hex: 30
Upper 3 bits ±16

10 Bus address
10.1 Address LSB
10.2 Address MSB
<b>10.3 Address</b>

10.3 Address
Dec:126 Hex: 7E

M	1	2	3	4	
½	-	-	½	½	M, LED 3 and LED 4 flash

Here the bus address of the SRD can be indicated and changed. The bus address is in the value range of 0 to 127; for the display 7 bits are required. Each bit has a specific value (bit 1=1, bit 2=2, bit 3=4, bit 4=8, bit 5=16, bit 6=32, bit 7=64). The bus address is then the total of the individual values.

To display this with 4 LEDs, selection must be made between the lower and upper 4 bits (whereby the highest bit 8 has no usage and is always 0)

**10.1 Selection of lower 4 bits:**

¼	¾	-	-	-	M short flash, LED 1 long flash
---	---	---	---	---	---------------------------------

With UP or DOWN key to selection of upper 4 bits:

**10.2 Selection of upper 4 bits:**

¼	-	-	-	¾	M short flash, LED 4 long flash
---	---	---	---	---	---------------------------------

Upon selection, the bits are displayed. When pressing UP or DOWN keys, the value is always changed by 1. Pressing keys UP+DOWN, the newly entered address will be activated.

The bus address is the total of the individual values:

Values of the **lower** 4 bits and the **upper** 4 bits:

	[1]	[2]	[4]	[8]	Value of the bits	-	[16]	[32]	[64]	-	Value of the bits
-	-	-	-	-	0	-	-	-	-	-	0
-	1	-	-	-	1	-	1	-	-	-	16
-	-	1	-	-	2	-	-	1	-	-	32
-	1	1	-	-	3	-	1	1	-	-	48
-	-	-	1	-	4	-	-	-	1	-	64
-	1	-	1	-	5	-	1	-	1	-	80
-	-	1	1	-	6	-	-	1	1	-	96
-	1	1	1	-	7	-	1	1	1	-	112
-	-	-	-	1	8						
-	1	-	-	1	9						
-	-	1	-	1	10						
-	1	1	-	1	11						
-	-	-	1	1	12						
-	1	-	1	1	13						
-	-	1	1	1	14						
-	1	1	1	1	15						

Note: Addresses 0 and 127 should not be used. Address 126 (delivery condition) is not permitted for cyclical operation. For further information see TI EVE0105 P.

In the version with LCD indicator, the address is displayed in decimal and hexadecimal number system.

**10.3 Address**

With LCD indicator, this function is recommended, whereby the address can be completely entered, without separation in LSB and MSB. The keys have auto repeat: By pressing and holding of a key UP or DOWN, the value is counted upward, after some time in larger steps.

**SRD991 with FOUNDATION Fieldbus:**  
**Menu 10: FF Configuration**

SRD Main Menu
8 Setpoint
9 Workbench
<b>10 FF Config</b>

10 FF Config
<b>10.1 Simulate</b>
10.2 Profile
10.3 Address

10.1 Simulate
<b>10.1.1 Disabled</b>
10.1.2 Enabled

10 FF Config
10.1 Simulate
<b>10.2 Profile</b>
10.3 Address

10.2 Profil
<b>10.2.1 Link Mast</b>
10.1.2 Basic fie

10 FF Config
10.1 Simulate
10.2 Profile
<b>10.3 Address</b>

M	1	2	3	4	
1/2	-	-	1/2	1/2	M, LED 3 and LED 4 flash

Special settings for Foundation Fieldbus device.

**10.1 Simulate enable / disable**

1/4	3/4	-	-	-	M short flash, LED 1 long flash
-----	-----	---	---	---	---------------------------------

The SRD991 sends during normal operation its actual Position Value<sup>1)</sup> back to the control system.  
If, however, "Simulate" is released in the SRD and in addition via communication Simulate is activated, then a simulation value coming from the control system is sent back as an actual value to the control system. In this way within the control system, e.g. the reaction to specific valve adjustments can be tested without having to adjust the valve – the SRD regulates toward the "accurate" set point value.

For further information about the Simulate see TI EVE0105 Q.

**10.1.1 Simulate Disabled**

-	1	-	-	-	LED 1 lights up
---	---	---	---	---	-----------------

Disable simulate. The real valve position will be indicated.

**10.1.2 Simulate Enabled**

-	-	-	-	1	LED 4 lights up
---	---	---	---	---	-----------------

Release simulate.

**10.2 Foundation Fieldbus Profile: Activate Link Master**

1/4	-	3/4	-	-	M short flash, LED 2 long flash
-----	---	-----	---	---	---------------------------------

**10.2.1 Link Master active**

-	1	-	-	-	LED 1 lights up
---	---	---	---	---	-----------------

This SRD becomes the Link Master if Control System is down.

**10.2.2 Basic field device**

-	-	-	-	1	LED 4 lights up
---	---	---	---	---	-----------------

This SRD becomes not the Link Master if Control System is down.

**10.3 Bus Address**

1/4	-	-	3/4	-	M short flash, LED 3 long flash
-----	---	---	-----	---	---------------------------------

Change address by using push buttons UP or DOWN.

By using the UP or DOWN keys the desired condition can be selected and entered through pressing keys UP+DOWN.

1) With the option "Position Feedback", the position-actual-value will be displayed, as before, as analog value 4 to 20 mA.

## 8.5 Setting of the travel indicator

The mechanical travel indicator is coupled to the feedback shaft of the positioner by a gear. The gear has two selectable ratios <sup>1)</sup> 1:2 and 1:6.

### Selecting gear ratio:

For rotation angles of the feedback shaft less than 30 ° select a ratio 1:6. This gear selection amplifies the feedback shaft rotation angle six times and for example, a 20 ° angle is shown as 120 °.

For rotation angles greater than 30 ° select a ratio of 1:2. This gear selection amplifies the shaft rotation angle by a factor of two and for example, a 45 ° angle is shown as 90 °.

For rotary actuators the rotation angle is equal to the rotation angle of the actuator. Consequently, a 90 ° rotation angle will result in a 180 ° display angle for the 1:2 gear ratio.

For linear actuators the rotation angle is determined by travel span and feedback lever length. In this case, an exact 180 ° display angle can only be achieved for a 30 ° rotation angle using a 1 : 6 gear ratio. If any other rotation angle results, either the closed or full open position can be set to be indicated at, for example 0 ° or 180 °. However, if the closed position is chosen for display, then the full open display position angle is dependent on travel span, feedback lever length and gear ratio. If the full open position is chosen for display, then the closed position angle becomes dependent.

### Setting gear ratio:

Remove the travel indicator **12**. Pull out the pin **12b** for a ratio 1:2 or push in the pin for a ratio 1:6. Use a smooth turning operation to free the gears and to set the pin **12b** against the stop. See illustration.

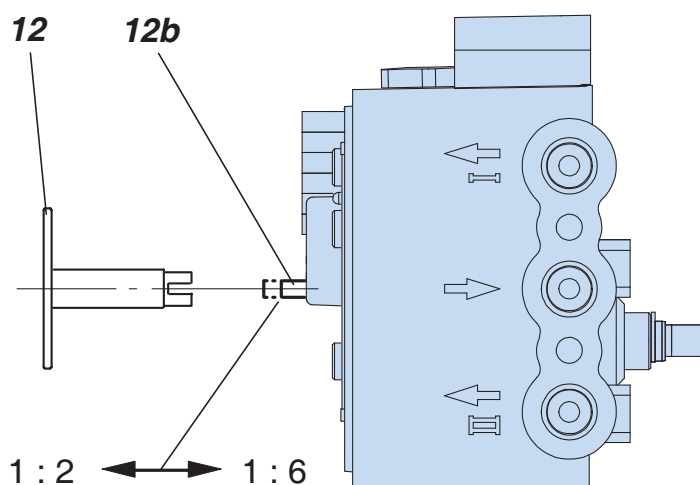

Turn the travel indicator **12** to the desired position, put it on the gear shaft against the stop and pinch the wire ring for secure coupling.

## 9 DECOMMISSIONING

Before decommissioning the unit, disconnect the supply air and the electrical input signal.

After disconnecting the electrical input signal, the last confirmed configuration of the positioner is preserved in the memory.

### Exchange of device

If a temporary decommissioning of the SRD and a later mounting to another actuator has to be carried out, before disconnecting, we recommend to Reset Configuration in Menu 9.1. So the default settings "Ex-Factory" are re-activated. This facilitates a later re-commissioning.

<sup>1)</sup> The values are rounded for making easier calculations.  
The exact ratios are 1:1.83 and 1:6.28.

## 10 MAINTENANCE

### General

The SRD991 requires no periodical maintenance. When replacing components during repair work, the safety requirements on page 52 must be observed!

### 10.1 Service connector and IrCom

All basic instruments of the SRD991 are equipped with a service plug. There via RS232 a PC with FDT/DTM Software can be connected via modem EDC82 (galv. separated, not Ex).

This universal interface, together with the PC software, allows the configuration of all SRD991 versions independent of the protocol – thus versions HART, FOUNDATION Fieldbus, PROFIBUS PA, and also the version “without communication” can be configured from the PC, without having to acquire expensive modems. For details see TI to EDC82.

The service plug (IDC connector) is accessible, if the cover **A** is pushed to the side.

The connector links EDC82 modem with SRD, and from EDC82 a 9 pole subD cable links to RS232 interface of PC.

### 10.2 Supply filter replacement

An obstructed supply filter can be replaced. Unscrew the air supply fitting, remove the filter and exchange the filter with a new one.

### 10.3 Removal of the electronics unit\*



#### WARNING

To avoid any personal injury resulting from bursting of parts, **take off air supply** before any removal of electronic board.

Pull off the travel indicator **12**. To remove the electronics unit **40**, loosen the 7 screws on the front.

Lift the electronic vertically upward.

Disconnect the plugs **41** and **42** (see illustration) from the board. Do not use tools to remove plugs, because components could be damaged. Tight-fitting plugs can be easily removed by tilting them diagonally inward before pulling them off.

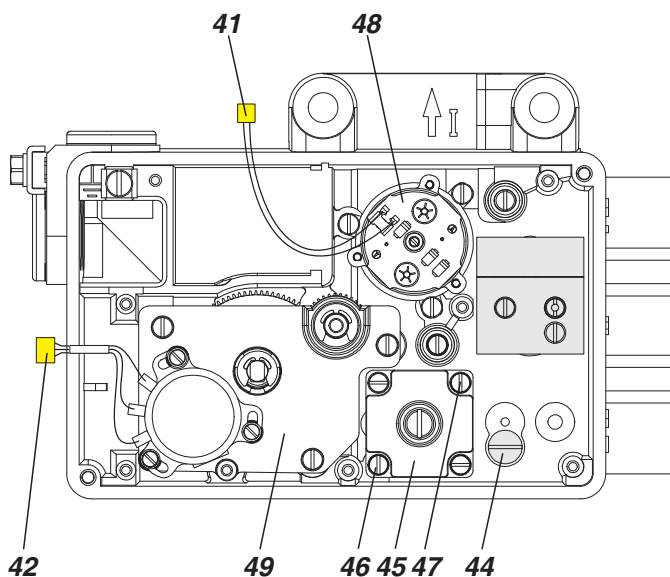
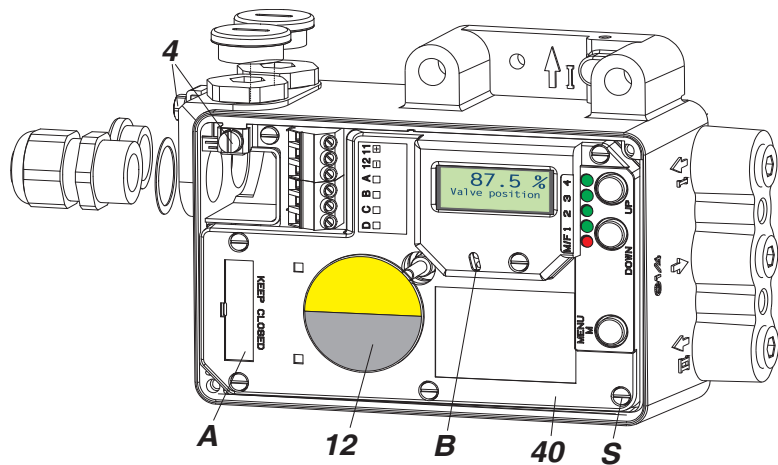

Connect the plugs **41** and **42** to the new electronics unit **40** and attach the new unit by using the 7 screws on the front (attention with the cables).

\* For SRD991 with 'pressure sensors' option, see page 22 Pressure sensors

## 11 TROUBLE-SHOOTING GUIDE

The components of the positioner are under constant surveillance by the installed micro controller. Errors detected are displayed in LCD or indicated by the LEDs.

Certain conditions (such as "Stroke limitation active") are displayed in LCD or indicated by the LEDs as message.

LED indication for diagnosis, errors

The following combinations are possible:

After start / reset: (X X X X = error code)

M 1 2 3 4

- X X X X Error detected during Init s. 11.1

Device in normal operation:

M 1 2 3 4

1 - - - - Cyclical self-test detects errors s. 11.2

- - - - - diagnosis without LED inform s. 11.3

3/4 x x x x flashing: message s. 11.4

### 11.1 Errors detected during initialization

After start-up or reset several initialization phases are passed through which are shown in LCD or in the green LEDs. If this phase stops an error was detected.

If after renewed reset <sup>1)</sup> the indicator stops at error code the device is probably defective; please contact customer service. Stating the error code will be of help to the Repair and Service Dept.

### 11.2 Errors detected during self-test

During cyclical self-test certain components of the SRD are under constant surveillance. At trouble detection in the electronics, output y1 becomes pressureless ('fail safe position').

If after reset <sup>1)</sup> the display shows the error again the device is probably defective; please contact customer service.

LED Error Codes (with LCD in true text)

red M	LEDs green				Description
	1	2	3	4	
-	1	1	1	1	Micro controller functional test
-	1	1	1	-	Micro controller RAM test
-	1	1	-	1	Micro controller ROM test
-	1	1	-	-	initialize operating system
-	1	-	1	1	initialize monitor
-	1	-	1	-	initialize interfaces
-	1	-	-	1	initialize timer
-	1	-	-	-	initialize EEPROM
-	-	1	1	1	initialize data
-	-	1	1	-	initialize ADC
-	-	1	-	1	initialize communication
-	-	1	-	-	initialize local operation
-	-	-	1	1	start background process
-	-	-	1	-	check options and start
-	-	-	-	1	start operating system

1 = LED constant light

red M	LEDs green				Description
	1	2	3	4	
1	-	-	-	-	Red LED lights up const. RAM / EPROM fault Actuate "Reset", send device-t to manufacturer if error re-appears

1 = LED constant light

1) Execute Reset by simultaneous pressing M+UP+DOWN keys, or by turn-off and restart of input signal

### 11.3 Diagnosis without LED or LCD inform

Fault	Possible cause	Solution
Positioner not operational using key pads	No input signal at 11, 12	Connect input signal
	Local operation blocked (write protection)	Remove blockage via communication
	No automatic power up (Reset)	Reset SRD with keys
	A key got jammed	Release cover screws, check menu functions, retighten cover
	Failure in the positioner	Contact customer service
Autostart not completed (> 45 min)	Actuator volume too large	stop Autostart and carry out extended Autostart, see chapter 8.4, Menu 2 or apply booster
	Failure in the positioner, otherwise Message 8, 9	carry out Autostart again, see chapter. 8.1 and 8.4, Menu 2 carry out Reset configuration send device to manufacturer
	Autostart remains stagnant for a longer time (>10 min) in step 1 or 2 (LED 1 or 2 lights up), otherwise message 8	Feedback lever (at stroke actuator) incorrectly mounted. Verify installation of feedback lever, see chapter 4; flat part points to arrow on housing Coupling piece (at rotary actuator) incorrectly turned (R and L mixed up): Verify direction of rotation, see chapter 4; flat part points to arrow on housing
	Autostart remains stagnant for a longer time (>10 min) in step 3 (LCD: shows "Control params") (LED: #3 lights up)	At large volume actuators the Autostart can possibly remain stagnant for a longer time (>10 min) in step 3, prior to continuing in step 4
Actuator does not react to a change in the input signal	No Autostart performed.	Perform Autostart.
	Positioner is not IN OPERATION	Switch positioner IN OPERATION, see chap. 8.2 resp. Autostart or via Configurator
	Set point source is configured wrong	Correct configuration via Configurator
Actuator does not attain the closed or opened position	Autostart not carried out	carry out Autostart
	Supply pressure too low	check supply air pressure
	Travel limit is set Message 12, 13	check settings, see chapter 8.4, Menu 5
	Angle position linearization, positioner action or characteristic curve is set incorrectly (e.g. 'Custom', but values are missing)	check settings, see chapter 8.4, Menus 1, 3, 4
Unstable behavior, position control circuit oscillates	Autostart incomplete, therefore, control parameters not suitable	carry out complete Autostart, see chapter 8.4,
	Small actuator volume but high air capacity	increase damping at pneumatic output, see chapter 8.4, Menu 6 reduce gain (P parameters)
	Friction on valve packing too great IP module or Pneumatic amplifier	loosen packing gland slightly or replace change module, pneumatic amp
Actuator leakage		Check the actuator and report
Actuator reacts too sluggishly	Air capacity insufficient	attach booster
	Gain set too low	increase damping at pneumatic output, see chapter 8.4, Menu 6
	Positioning time T63 set too high	reduce positioning time, see chapter 8.4 Menu 6
No communication possible	Input voltage too low	Eliminate voltage drop
	Faulty protocol, communicator and device type do not match	Check configuration of devices
	Wrong electronics unit	change device

For tuning controller parameters see remarks on page 38.



**11.4 Messages** SRD with option "Built-in pressure sensors", flashing is superimposed by a flickering

LEDs	Description of message / LCD text	Remedy
------	-----------------------------------	--------

M	1	2	3	4	
¾	¼	-	-	-	<b>Write protected</b>
Message 1: write protection	Parameter and functions are write-protected		Can be changed via Configurator, FDT/DTM Software or Profile 3.0 (PROFIBUS)		

M	1	2	3	4	
¾	-	¼	-	-	<b>Bad config CRC</b>
Message 2: Parameter	Invalid, undefined parameter values		Reset of configuration to factory setting in Menu 9.1		

M	1	2	3	4	
¾	¼	¼	-	-	<b>Calib invalid</b>
Message 3: Calibration	Incomplete calibration or entering value resp. calibration value outside of permissible tolerance range		Repeat calibrations in Menus 9.2 to 9.5		

M	1	2	3	4	
¾	-	-	¼	-	<b>Ill loop current</b>
Message 4: Input current outside of operating range	Check nameplate (INPUT) for correct version Message appears at: Analog or HART: input current under approx. 3.8 mA or above approx. 22 mA Fieldbus: input current under approx. 9 mA or above approx. 12 mA		Check supply voltage (Analog) or check Bus voltage (Fieldbus), exchange SRD if necessary		

M	1	2	3	4	
¾	¼	-	¼	-	<b>Pot problem</b>
Message 5: Position sensor	Position sensor input recognizes error		Check 3-pole plug at electronic board Check cable to sensor Check sensor (Potentiometer: 5k +20% -0%)		
Positioner already calibrated, dismantled and supplied. If you supply (4-20 mA or with a fieldbus) a not mounted positioner and bring the potentiometer out of range, the message will appear and remain till the potentiometer goes again in range and the error is validated with push button.	Position not within permissible rotation angle range. Lower deviation of the original 0% and exceeding of the original 100%, which have been determined by Autostart.		Check feedback lever mounting (flat area points to arrow on housing)		
	During Autostart a change of the direction of movement was found		Acknowledge with UP+DOWN keys, then o.k.		
			Check further possible reasons: valve seat worn-out; spindle lock out-of-line; carrier unit on spindle lock is damaged (for determination of valve position).		

M	1	2	3	4	
¾	-	¼	¼	-	<b>IP motor problem</b>
Message 6: I/P-converter output	Connection I/P converter to electronic board faulty		Check 2-pole plug at electronic board Check cable to the I/P converter Check I/P converter to detect short circuit or interruption		

M	1	2	3	4	
¾	¼	¼	¼	-	<b>No supply press</b>
Message 7: Air supply / pneumatic error	Detection: spring closes: w > 2 %, but position < 1 % spring opens: w < 98 %, but position > 99 % without spring: no actuator changes in direction of position		Check air supply pressure Lead cable separated Possibly poor control parameters are set Pneumatic parts blocked		

LEDs	Description of message / LCD text	Remedy
------	-----------------------------------	--------

M	1	2	3	4	
3/4	-	-	-	1/4	<b>Autostart err 1</b>
Message 8: AUTOSTART defective	Air supply too low Feedback lever (linear actuator) or Coupling (rotary actuator) incorrectly linked. Potentiometer moves out of operating range of ± 47 % of 0° position		Check air supply Check mounting. Flat area points to arrow on housing		
	Coupling (rotary actuator) incorrectly linked (R and L interchanged)		Check mounting		
	Pneumatic output to actuator closed or untight/ When direct mounting onto FlowTop or FlowPak, the screw plug y1-d is not removed.		Check pneumatic connections		
	Mechanical stops not determinable		Check spring movement of actuator / check air supply / Check mounting		
	When using a booster or spool valve, no control parameters can be determined, since air capacity is too high.		Device version is not suitable for this actuator; select version with smaller air capacity or remove booster.		
	Control parameter too high since air capacity is too high (in general, oscillation in valve movement)		Use a booster or the version with spool valve. Reduce control parameter prop.-gain (Menu 6.1 and 6.2)		
	Possibly incomprehensible configuration data		Reset configuration, see Menu 9.1		

M	1	2	3	4	
3/4	1/4	-	-	1/4	<b>Autostart err 2</b>
Message 9: AUTOSTART defective	Configuration to single-acting instead of double-acting actuator		Initialize factory calibration for double-acting in Menu 9.7		

M	1	2	3	4	
3/4	-	1/4	-	1/4	<b>Optionboard err</b>
Message 10: Disturbances at Option board	Configured status of the SRD deviates from existing version (e.g. Option board has been inserted subsequently).		Check if correct option board has been connected Confirm message and thereby new instrument version.		
	Bad contact		Connections to terminals are interchanged Check connections Tighten electronics		
	Defective		Exchange option board		

M	1	2	3	4	
3/4	1/4	1/4	-	1/4	<b>Ctrl diff error</b>
Message 11: Remaining control deviation	Actuator problems (high friction or blocked)		Check actuator		
	Insufficient air supply		Check air supply / air filter		
	Insufficient parameters for position controls, for example, amplification too small		Check control parameter, check pneumatic components		
	IP module or pneumatic amplifier defect		Check in Menu 7; replace if necessary		

M	1	2	3	4	
3/4	-	-	1/4	1/4	<b>Lower stroke lim</b>
Message 12: configured closing limit has been reached	If this is desired, the message may be ignored, of course.		If not, the setting has to be checked in Menu 5.1 or via communication		

M	1	2	3	4	
3/4	1/4	-	1/4	1/4	<b>Upper stroke lim</b>
Message 13: configured opening limit has been reached	If this is desired, the message may be ignored, of course.		If not, the setting has to be checked in Menu 5.4 or via communication		

LEDs	Description of message / LCD text	Remedy
------	-----------------------------------	--------

M	1	2	3	4	<b>Maintenance</b>			
3/4	-	1/4	1/4	1/4	<table border="1"> <tr> <td data-bbox="129 423 368 512">Message 14: Maintenance required</td> <td data-bbox="368 423 903 512">Operating point of controller is outside of permissible tolerance</td> <td data-bbox="903 423 1439 512">Pneumatic components have to be checked and if necessary readjusted. Filters are possibly blocked and have to be replaced</td> </tr> </table>	Message 14: Maintenance required	Operating point of controller is outside of permissible tolerance	Pneumatic components have to be checked and if necessary readjusted. Filters are possibly blocked and have to be replaced
Message 14: Maintenance required	Operating point of controller is outside of permissible tolerance	Pneumatic components have to be checked and if necessary readjusted. Filters are possibly blocked and have to be replaced						

M	1	2	3	4	<b>Unforeseen</b>			
3/4	1/4	1/4	1/4	1/4	<table border="1"> <tr> <td data-bbox="129 598 368 633">Message 15:</td> <td data-bbox="368 598 903 633">Not defined</td> <td data-bbox="903 598 1439 633"></td> </tr> </table>	Message 15:	Not defined	
Message 15:	Not defined							

## 12 SAFETY REQUIREMENTS

### 12.1 EMC and CE

For notes regarding Electromagnetic compatibility EMC and CE labels see Product Specifications Sheet PSS EVE0105 A.

In order to ensure EMC protection, the black electronic cover made of conductive plastic has to be screwed to the housing, see page 46.

### 12.2 Explosion protection

(Only if ordered)

Technical data for explosion protection see Product Specifications Sheet PSS EVE0105 A or Certificates of Conformity EX EVE0105 A.

For installations located in explosive atmospheres, all relevant national regulations and installation conditions must be observed, e.g. in the Federal Republic of Germany ElexV and DIN VDE 0165.

#### Attention:

When repairing explosion-protected equipment, observe the national regulations.

Repairs involving parts must be manufacturer's original parts.

The following applies to the Federal Republic of Germany: Repairs involving parts required for explosion protection must either be carried out by the manufacturer or by authorized personnel and confirmed by certificate.

## 13 SYSTEM CONFIGURATION

The safety requirements (see above) must be observed!

### 13.1 HART Communication

When using the 'communication' (an alternating current signal, which is modulated onto the 4-20 mA signal), it must be observed that the connected outputs are suitable for the used frequency ranges. Apart from the load, also the alternating current impedances have to be observed.

It is recommended therefore to use only suitable instruments.

To eliminate crosstalk between leads and to reduce disturbances through electromagnetic influences, it is recommended to use twisted paired shielded leads (0.3 to 2.5 mm<sup>2</sup>, max. 100 pF/m).

The capacities of the leads and the connected instruments must not exceed the maximum values for HART.

All components which are connected to the SRD in an explosion hazardous area, require an Ex-Approval. The applicable limit values must not be exceeded. These limit values also have to be adhered to when connecting additional capacitances, inductances, voltages, and currents.

#### Measuring HART Communication Signal

If a reliable communication signal can't be received, it is advisable to check the level with an oscilloscope. The first data block always comes from the Configurator and the second block is the reply from the SRD.

HART	measured at configurator:	measured at SRD:
Configurator transmits	at least 350 mVpp	at least 120 mVpp
SRD991 transmits	at least 120 mVpp	at least 400 mVpp

### 13.2 With Communication PROFIBUS-PA

The operation of the positioner takes place digital, as per PROFIBUS-PA Profile Class B acc. to EN 50170 and DIN 19245 part 4. Data transmission via bit synchronous current modulation with a speed of 31250 bits via twisted and shielded two-wire connections acc. to IEC 1158-2, with cable shields on both sides and bus terminators according to recommendation IEC 1158-2.

The positioner has to be connected to a segment coupler, which has to be conforming to IEC 1158-2. For operation in explosion hazardous areas, a segment coupler in explosion proof version has to be used. Supply as well as communication takes place via the bus.

All components which are connected to the SRD in an explosion hazardous area, require an Ex-Approval. The applicable limit values must not be exceeded in any event. These limit values also have to be adhered to when connecting additional capacitances, inductances, voltages and currents. The FISCO model is thereby used as a basis.

Further information for observance: "Technical Guide for PROFIBUS-Connection Technique" PROFIBUS-User Organisation, Order no. 2.141

### 13.3 With Communication FOUNDATION Fieldbus

The operation of the positioner takes place digital, as per FOUNDATION Fieldbus Specification Rev. 1.4. Data transmission via bit synchronous current modulation with a speed of 31250 bits of via twisted and shielded two-wire connections acc. to IEC 1158-2, with cable shields on both sides and bus terminators according to recommendation IEC 1158-2.

The positioner has to be connected to components which are conforming to IEC 1158-2. For operation in explosion hazardous areas, an Ex-separator has to be used. Supply as well as communication takes place via the bus.

All components which are connected to the SRD in an explosion hazardous area, require an Ex-Approval. The applicable limit values must not be exceeded in any event. These limit values also have to be adhered to when connecting additional capacitances, inductances, voltages and currents. The FISCO model is thereby used as a basis.

Further information for observance:  
"Wiring and Installation 31.25 kBit/s, Voltage Mode, Wire Medium Application Guide" by FOUNDATION fieldbus

### 13.4 System configuration

#### Electrical connection

Connection compartment see page 20

#### Electrical connection for SRD991 in intrinsic safe (Ex i) version

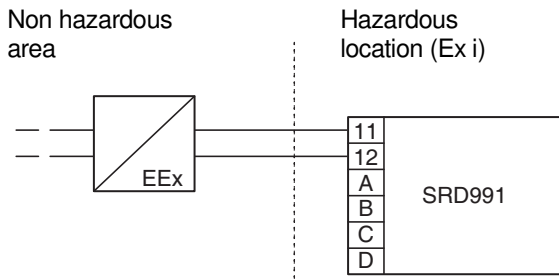

#### Terminals:

	Input		Options			
	11	12	A	B	C	D
Input signal / Setpoint value						
HART 4-20mA	11+	12-				
Fieldbus acc. to IEC 1158-2	11**	12**				
Options / Additional In-/Outputs						
Position feedback			81+	82-	83+	84-
Binary in / output			81+	82-	83+	84-
Binary input			13+	14-	15+	16-
Limit signal switch			41+	42-	51+	52-
Potentiometer						
Sensor						

\*\* any Polarity

#### Connection values

##### HART / 4-20 mA

Terminals ..... 11+ / 12-  
Signal range ..... 4 to 20 mA  
Input voltage ..... DC 12 to 36 V (without load)

##### FOUNDATION Fieldbus

Terminals ..... 11 / 12  
Bus connection ..... Fieldbus interface acc. to IEC 1158-2  
Supply voltage ..... DC 9 to 32 V <sup>1)</sup>  
max. Supply voltage ..... DC 36 V  
Operating current ..... 10.5 mA ± 0.5 mA

#### PROFIBUS-PA

Terminals ..... 11 / 12  
Bus connection ..... Fieldbus interface acc. to IEC 1158-2  
Supply voltage ..... DC 9 to 32 V <sup>2)</sup>  
max. Supply voltage ..... DC 36 V  
Operating current ..... 10.5 mA ± 0.5 mA

#### Communication HART and ATEX Certification

**Electrical classification** <sup>2) 3)</sup>  
see Certificates of Conformity EX EVE0105 A

#### Communication PROFIBUS-PA and FOUNDATION Fieldbus H1

**Electrical classification** <sup>2) 3)</sup>  
see Certificates of Conformity EX EVE0105 A

#### 4-20 mA Intelligent without Communication with ATEX Certification

**Electrical classification** <sup>2) 3)</sup>  
see Certificates of Conformity EX EVE0105 A

1) When used in Ex-hazardous areas, the max. supply voltages, etc. on nameplate resp. certificate of conformity, has to be observed!  
2) With appropriate order only  
3) National requirements must be observed

14 DIMENSIONS

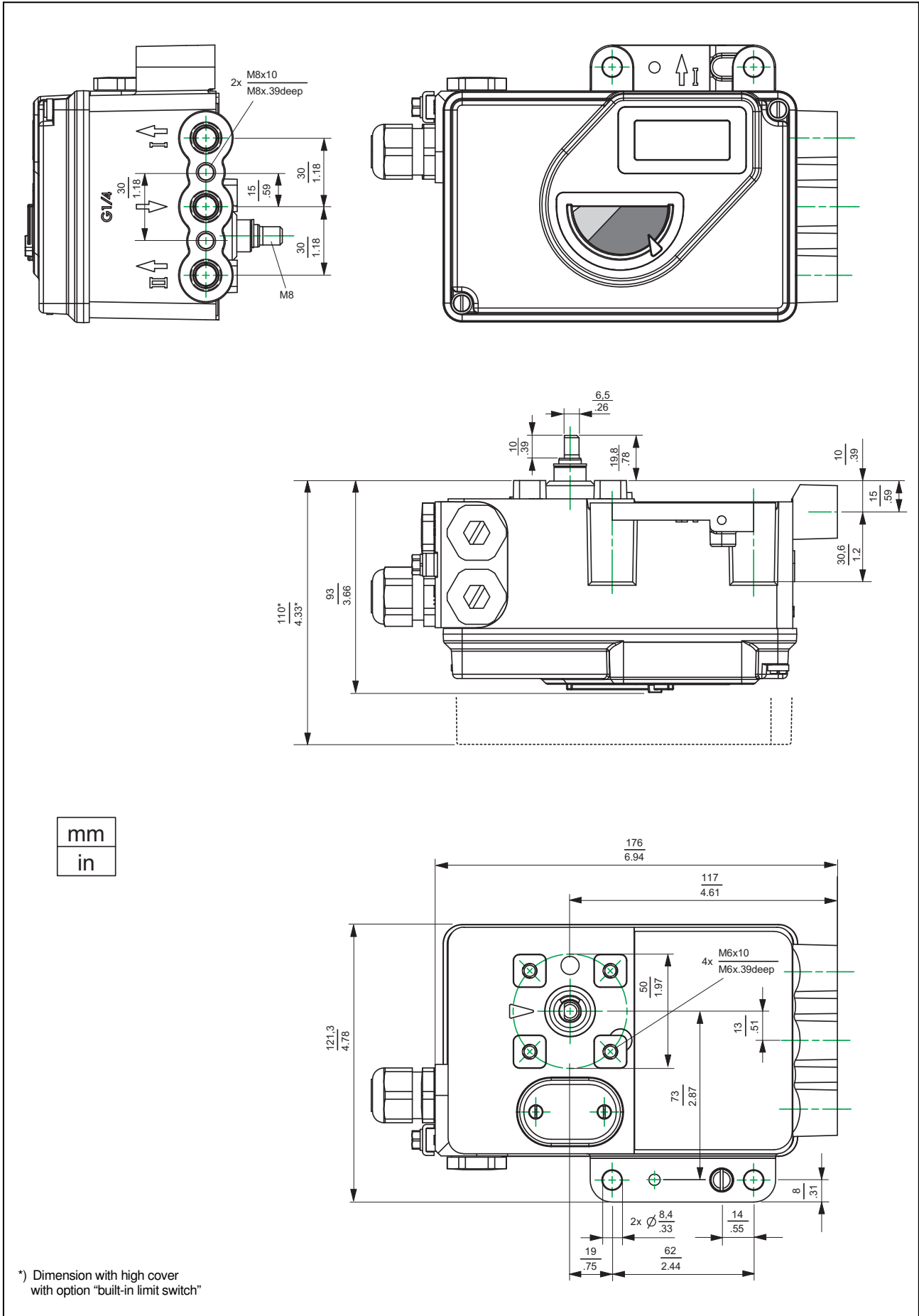

**DIMENSIONS INOX** SRD991 in stainless steel housing

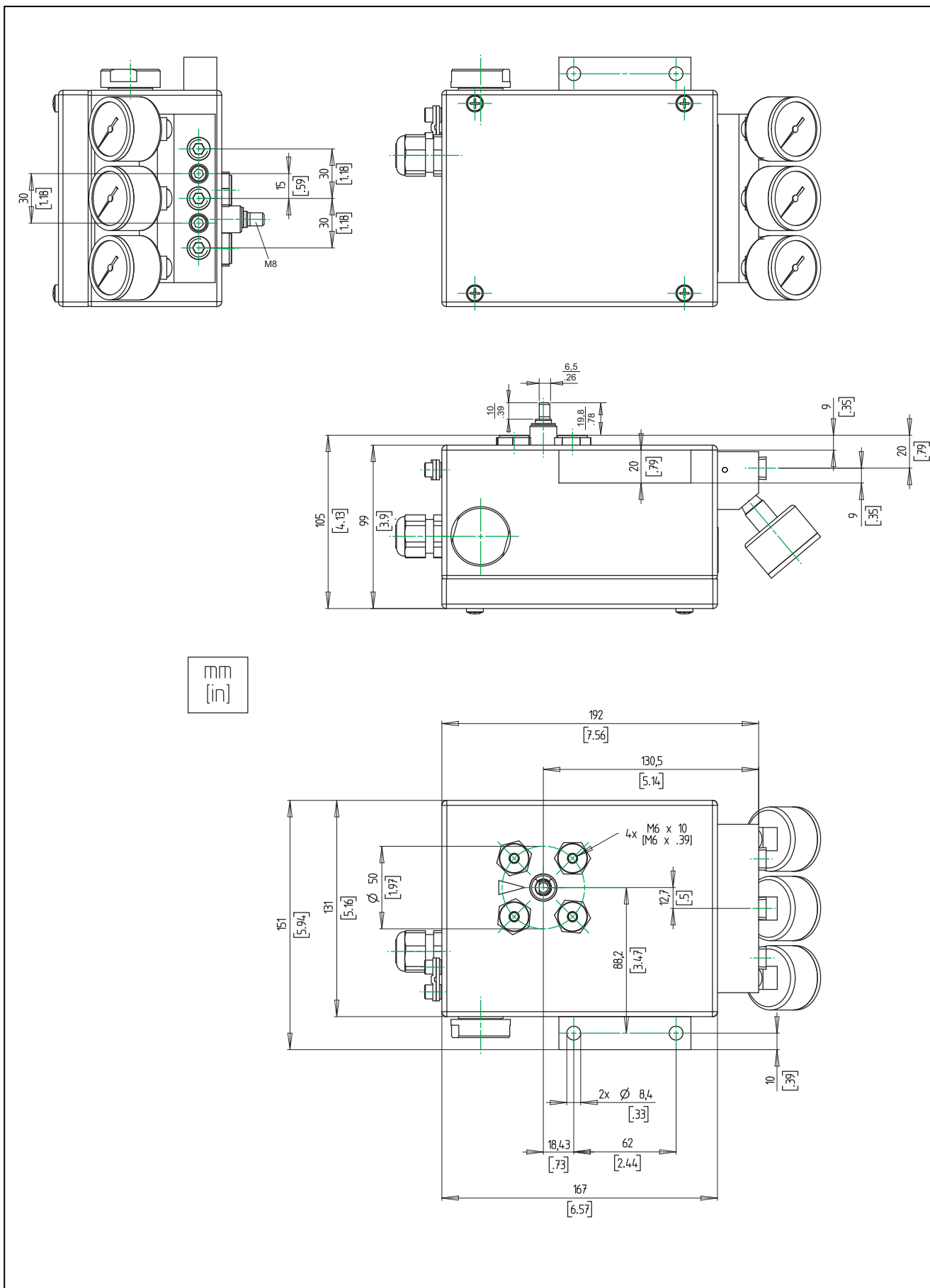

Schneider Electric Systems USA, Inc.  
38 Neponset Avenue  
Foxboro, MA 02035  
United States of America  
<http://www.schneider-electric.com>

Global Customer Support  
Inside U.S.: 1-866-746-6477  
Outside U.S.: 1-508-549-2424  
<https://pasupport.schneider-electric.com>

Copyright 2010-2018 Schneider Electric  
Systems USA, Inc. All rights reserved.

\*\*Schneider Electric is a trademark\*\* of  
Schneider Electric Systems USA, Inc., its  
subsidiaries, and affiliates. All other trademarks  
are the property of their respective owners.

