

LG01 Guided Wave Radar Level Meter



The LevelWave LG01 is designed to perform continuous level measurement in a wide range of industries and applications. Foxboro is known for more than 50 years of experience in level measurement as a leading supplier of extremely robust, durable and reliable level measurements. Unaffected by changes in temperature, specific gravity, pressure and with no need to recalibrate, offering a highly available measurement at low maintenance cost. With the LevelWave LG01 you achieve a highly modular system which is designed for the requirements of the modern industry.

FEATURES

- 2-wire Loop powered TDR technology
- 360° rotatable housing with snap solution
- Housing and cover with bayonet connectors
- Horizontal or vertical housing position
- Remote electronics (up to 100 m / 328 ft)
- Weather protection cap
- Measuring range up to 40 m / 130 ft
- Measurements down to 1.1 DK possible
- Quick Noise Scanning (QNS) function
- HART Communication, 4 to 20 mA
- Configuration via FDT-DTM
- Continuous self-diagnostics, Status and diagnostic messages, acc. to NE 107
- Process temperature from -50 to +300 °C
- Process pressure from -1 to 40 bar
- SIL2-compliant acc. to IEC 61508 for safety related systems
- Local multilingual full graphic LCD, configurable in %, mA or physical units
- Display with external keypad

Life Is On

Foxboro[™]
by Schneider Electric

Contents

| | | |
|----------|--|-----------|
| 1 | General safety information | 5 |
| <hr/> | | |
| 1.1 | Scope of the document..... | 5 |
| 1.2 | Device description | 5 |
| 1.3 | Standards and approvals..... | 5 |
| 1.4 | Device categories | 6 |
| 1.4.1 | Ex ia-approved devices | 6 |
| 1.4.2 | Ex ia/db, Ex db ia, Ex ia/tb and Ex ia tb-approved devices | 6 |
| 1.4.3 | Ex ic-approved devices..... | 6 |
| 1.5 | ATEX nameplates..... | 7 |
| 2 | Installation | 9 |
| <hr/> | | |
| 2.1 | Precautions..... | 9 |
| 2.1.1 | General notes | 9 |
| 2.1.2 | Electrostatic discharge..... | 9 |
| 2.2 | Operating conditions..... | 10 |
| 2.2.1 | Ambient and flange temperature | 10 |
| 2.2.2 | Maximum surface temperature of the housing for dust applications | 16 |
| 2.2.3 | Process pressure | 16 |
| 3 | Electrical connections | 17 |
| <hr/> | | |
| 3.1 | General notes | 17 |
| 3.2 | Terminal compartment..... | 17 |
| 3.2.1 | How to open the terminal compartment..... | 17 |
| 3.2.2 | How to close the terminal compartment | 18 |
| 3.3 | Terminal tightening capacity | 19 |
| 3.4 | Equipotential bonding system..... | 19 |
| 3.5 | Ex ia equipment..... | 20 |
| 3.5.1 | How to connect the electrical cables | 20 |
| 3.5.2 | Maximum intrinsically-safe values for the electrical circuit | 20 |
| 3.5.3 | Supply voltage | 20 |
| 3.5.4 | Electrical schematic | 21 |
| 3.6 | Ex ia/db, Ex db ia, Ex ia/tb and Ex ia tb equipment..... | 22 |
| 3.6.1 | General notes | 22 |
| 3.6.2 | How to connect the electrical cables | 22 |
| 3.6.3 | Supply voltage | 23 |
| 3.6.4 | Electrical schematic | 24 |
| 3.7 | Ex ic equipment | 25 |
| 3.7.1 | How to connect the electrical cables | 25 |
| 3.7.2 | Maximum intrinsically-safe values for the electrical circuit | 25 |
| 3.7.3 | Supply voltage | 25 |
| 3.7.4 | Electrical schematic | 26 |
| 4 | Start-up | 27 |
| <hr/> | | |

| | |
|---|----|
| 5 Service | 28 |
| 5.1 Periodic maintenance | 28 |
| 5.2 Keep the device clean | 28 |
| 5.3 Manufacturer | 28 |
| 5.4 Returning the device to the manufacturer | 28 |
| 5.4.1 General information | 28 |
| 5.4.2 Form (for copying) to accompany a returned device | 30 |

1 General safety information

1.1 Scope of the document

These instructions are applicable only to the explosion-protection version of the TDR level transmitter. For all other data, use the Handbook. If you do not have these documents, please contact the nearest office or download them from the manufacturer's internet site.



INFORMATION!

The information in these supplementary instructions only contains the data applicable to explosion protection. The technical data for the non-Ex version in the Handbook shall be valid in its current version, provided that it is not rendered invalid or replaced by these supplementary instructions.



WARNING!

Installation, commissioning and maintenance may only be carried out by "Personnel trained in explosion protection".

1.2 Device description

This device is a 2-wire level transmitter that uses TDR (Time Domain Reflectometry) / Guided Radar technology. It measures the level, distance, volume and mass of liquids, liquid gases, pastes, powders, slurries and granular products. Measurements are displayed via a DTM (device type manager) for remote communication or an optional integrated display screen with wizard-driven setup and online help functions.

The level transmitter is approved for use in potentially explosive atmospheres when equipped with the appropriate options.

1.3 Standards and approvals



DANGER!

In compliance with European Directive 2014/34/EU (ATEX 114), the ATEX version of the device described in these Supplementary Instructions agrees with European Standards EN 60079-0:2012 +A11, EN 60079-1:2014, EN 60079-11:2012, EN 60079-26:2015 and EN 60079-31:2014. The Ex ia, Ex ia/db, Ex db ia, Ex ia/tb, Ex ia tb and Ex ic versions are certified for use in hazardous areas by the DEKRA Certification B.V. under the EU-Type Examination Certificate DEKRA 13ATEX0180 X.



WARNING!

Carefully read the ATEX approval certificate. Obey the boundary conditions.

1.4 Device categories

1.4.1 Ex ia-approved devices

The Ex ia-approved device is suitable for use in potentially explosive atmospheres of all flammable substances in Gas Groups IIA, IIB and IIC. It is certified for applications requiring Category 1/2 G (gases, vapours or mists) and EPL Ga/Gb equipment or 2 G and EPL Gb equipment when fitted with the appropriate options.

The Ex ia-approved device is suitable for use in potentially explosive atmospheres of all flammable substances in Dust Groups IIIA, IIIB and IIIC. It is certified for applications requiring Category 1/2 D (dust) and EPL Da/Db equipment or 2 D and EPL Db equipment when fitted with the appropriate options.

1.4.2 Ex ia/db, Ex db ia, Ex ia/tb and Ex ia tb-approved devices

The Ex ia/db- and Ex db ia-approved device is suitable for use in potentially explosive atmospheres of all flammable substances in Gas Groups IIA, IIB and IIC. It is certified for applications requiring Category 1/2 G (gases, vapours or mists) and EPL Ga/Gb equipment or 2 G and EPL Gb equipment when fitted with the appropriate options.

The Ex ia/tb and Ex ia tb-approved device is suitable for use in potentially explosive atmospheres of all flammable substances in Dust Group IIIA, IIIB and IIIC. It is certified for applications requiring Category 1/2 D (dust) and EPL Da/Db equipment or 2 D and EPL Db equipment when fitted with the appropriate options.

1.4.3 Ex ic-approved devices

The Ex ic-approved device is suitable for use in potentially explosive atmospheres of all flammable substances in Gas Groups IIA, IIB and IIC. It is certified for applications requiring Category 3 G (gases, vapours or mists) and EPL Gc equipment when fitted with the appropriate options.

The Ex ic-approved device is suitable for use in potentially explosive atmospheres of all flammable substances in Dust Group IIIA, IIIB and IIIC. It is certified for applications requiring Category 3 D (dust) and EPL Dc equipment when fitted with the appropriate options.

1.5 ATEX nameplates

Signal converter housing (compact and remote (field) versions)

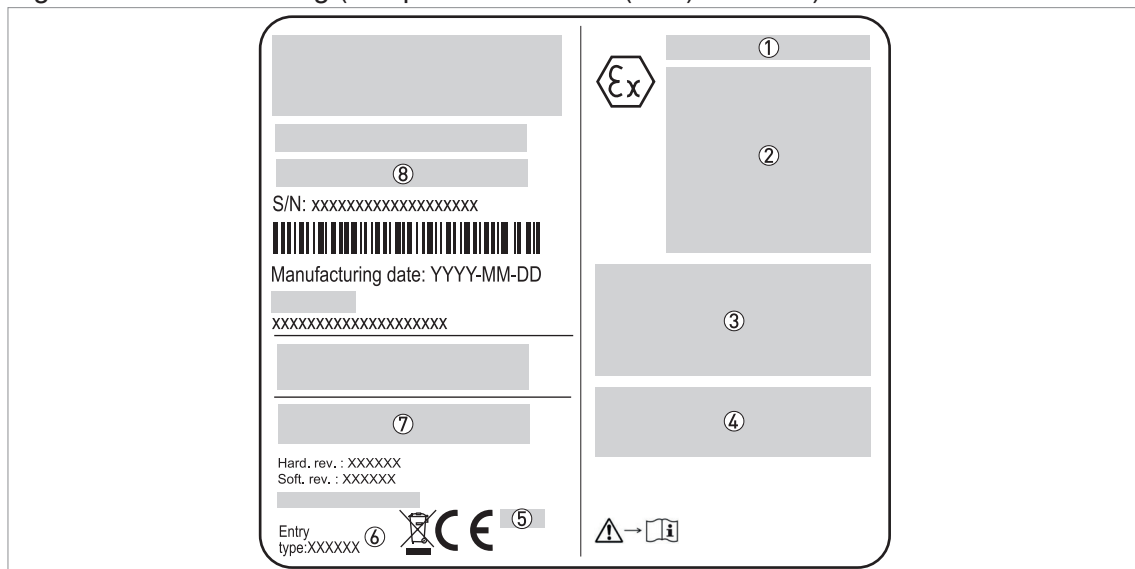

Figure 1-1: Nameplate on the signal converter housing (compact and remote (field) versions)

- ① ATEX certification number
- ② Equipment approval category (explosive atmosphere – gas), types of device protection including approved Gas Groups and temperature classes (T6...T3 or T2 – depends on the probe type) and equipment protection level
Equipment category (explosive atmosphere – dust), types of device protection including approved Gas Groups, maximum surface temperature degree of ingress protection (if fitted with the appropriate cable glands) and equipment protection level
- ③ **4...20 mA passive – HART output option (Ex ia or Ex ic approvals):** Intrinsically-safe circuit data
4...20 mA passive – HART output option (Ex ia/db, Ex db ia, Ex ia/tb and Ex ia tb approvals): Maximum voltage in accordance with EN 60079-0. Refer to ④ for the input voltage range.
Fieldbus (FF or PROFIBUS PA) options: Entity or FISCO power supply parameters
- ④ **4...20 mA passive – HART output option (Ex ia/db, Ex db ia, Ex ia/tb and Ex ia tb approvals):** Minimum waiting time after power-off before it is safe to open the terminal compartment
- ⑤ Notified body number (production site)
- ⑥ Cable entry type and size (M20×1.5 or ½ NPT)
- ⑦ Input voltage range and maximum current (4...20 mA passive – HART) / basic current (FF or PROFIBUS PA)
- ⑧ Type code – for more data, refer to "Order code" in the handbook

Probe housing (remote (field) version)

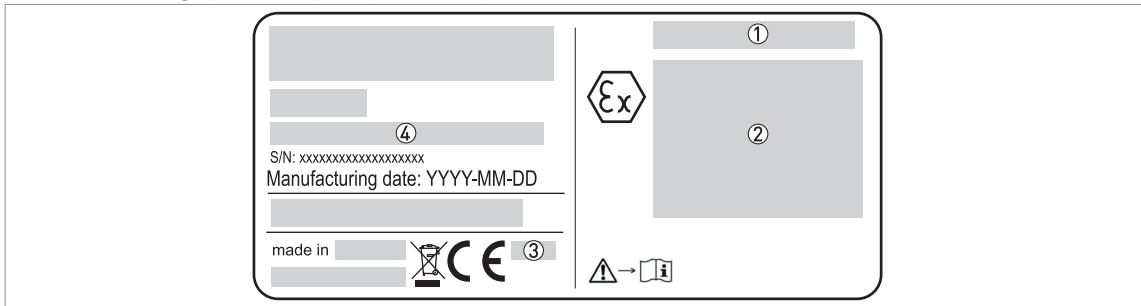

Figure 1-2: Nameplate on the probe housing (remote (field) version)

- ① ATEX certification number
- ② Equipment approval category (explosive atmosphere – gas), types of device protection including approved Gas Groups, temperature classes (T6...T3 or T2 – depends on the probe type) and equipment protection level
Equipment category (explosive atmosphere – dust), types of device protection for explosive atmospheres with dust, zones, maximum surface temperature, equipment protection level and degree of ingress protection (if fitted with the appropriate cable glands)
- ③ Notified body number (production site)
- ④ Type code – for more data, refer to "Order code" in the handbook

2 Installation

2.1 Precautions

2.1.1 General notes



WARNING!

When you install the device, obey the conditions in the EU-Type Examination certificate. These conditions include:

- The special conditions for safe use.
- The Essential Health and Safety Requirements.

You can download the certificate from our internet site.



DANGER!

This installation must agree with EN 60079-14: Explosive atmospheres – Part 14: Electrical installations design, selection and erection.



DANGER!

The device contains a PTFE boundary wall between the process and the signal converter. Do not use the device in the process if the PTFE part is not resistant to corrosion by the tank product.

2.1.2 Electrostatic discharge



DANGER!

Risk of electrostatic discharge from:

- the painted surfaces of the aluminium housing
- the plastic protective sheathes (PVC, PVDF or PP) on single rod probes, and
- the coated single cable probes (PFA, PP, PTFE, FEP)



DANGER!

Take the necessary antistatic precautions if:

- you handle the device in potentially explosive atmospheres,
- you install the device in potentially explosive atmospheres or
- you use the device in potentially explosive atmospheres.

Install the device correctly to prevent electrostatic discharge. Make sure that all equipment is correctly grounded.

Make sure that the housing and adjacent objects do not rub together.

If dirt collects on the device, clean it with a damp cloth.

Do not install in a location where the electrostatic charge can increase. This includes:

- locations near ventilation systems,
- locations where there is a risk of an increase in electrostatic charge caused by compressed air and dust,
- locations near machines that use friction,
- locations near systems that apply electrons as a spray (e.g. near electrostatic painting systems), and
- locations near other machines and systems that can have large electrostatic charges.

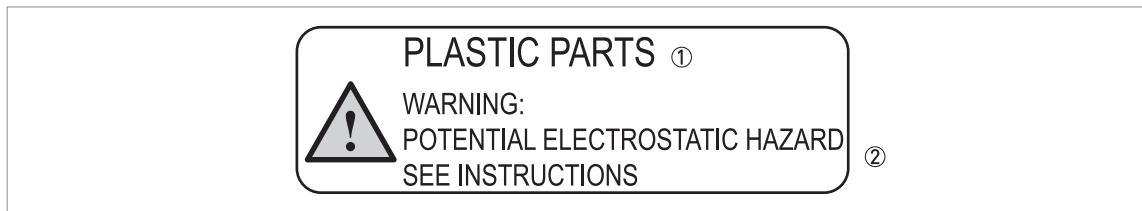

Figure 2-1: ESD warning sticker (below the device nameplate)

- ① Text: Plastic Parts
- ② Text: Warning! Potential electrostatic hazard – see instructions

2.2 Operating conditions

The allowable ambient temperature and corresponding flange temperature range for the device depends on the temperature classes marked on the nameplate.

2.2.1 Ambient and flange temperature

The ATEX equipment category, IEC equipment protection level and temperature class give the ambient temperature and related flange temperature ranges for the device.



WARNING!

The gasket temperature must be in the approved limits. For more data, refer to "Pressure and temperature ranges" in the Installation chapter of the handbook.

Definitions

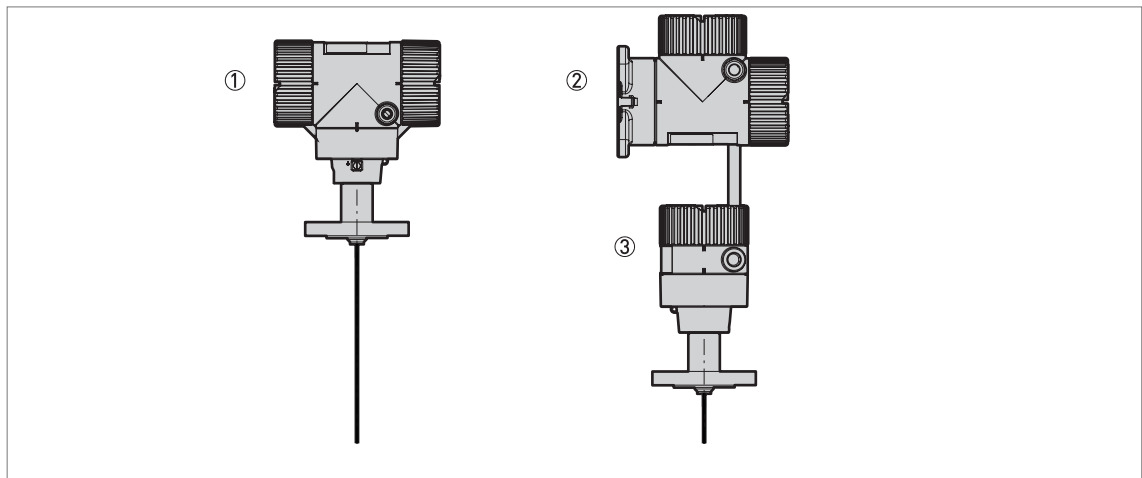

Figure 2-2: Definitions

- ① Compact version: Signal converter, process connection and probe
- ② Remote (Field) version: remote converter
- ③ Remote (Field) version: probe housing, process connection and probe



WARNING!

Compact version only: If the device is used in a potentially explosive atmosphere that contains dust, do not install the device on the side of the tank.

If the device must operate at a high process temperature, make sure that the maximum flange temperature and maximum ambient temperature are not more than the values given in the table.



INFORMATION!

If the device is equipped with the Metaglas® option, use the values that follow.

Compact version

Equipment category 2 G or EPL Gb: Ex ia and Ex db ia devices

Equipment category 3 G or EPL Gc: Ex ic devices

| Temperature class | Maximum ambient temperature | | | | | | Max. flange temperature | |
|-------------------|--|------|--|------|-----------------------|------|-------------------------|--------|
| | Ø2 mm / Ø0.08" single cable probe (HT version) | | Ø2 mm / Ø0.08" single cable probe (other versions) | | All other probe types | | | |
| | [°C] | [°F] | [°C] | [°F] | [°C] | [°F] | [°C] | [°F] |
| T6 | +54 | +129 | +52 | +125 | +53 | +127 | +60 | +140 |
| | +51 | +124 | +42 | +107 | +45 | +113 | +85 | +185 |
| T5 | +69 | +156 | +67 | +152 | +68 | +154 | +75 | +167 |
| | +66 | +151 | +57 | +134 | +60 | +140 | +100 | +212 |
| T4 | +79 | +174 | +77 | +170 | +78 | +176 | +85 | +185 |
| | +76 | +169 | +67 | +152 | +70 | +158 | +110 | +230 |
| | +73 | +163 | +57 | +134 | +62 | +143 | +135 | +275 |
| T3 | +71 | +160 | +51 | +124 | +57 | +134 | +150 | +302 |
| | +68 | +154 | - | - | - | - | +180 ① | +356 ① |
| | +65 | +149 | - | - | - | - | +200 ① | +392 ① |
| T2 | +60 | +140 | - | - | - | - | +250 ① | +482 ① |
| | +54 | +129 | - | - | - | - | +300 ① | +572 ① |

① Make sure that gasket temperature is in the specified limits. For more data, refer to the handbook.

| Temperature class | Minimum ambient temperature | | | | | | Min. flange temperature | |
|-------------------|--|------|--|------|-----------------------|------|-------------------------|-------|
| | Ø2 mm / Ø0.08" single cable probe (HT version) | | Ø2 mm / Ø0.08" single cable probe (other versions) | | All other probe types | | | |
| | [°C] | [°F] | [°C] | [°F] | [°C] | [°F] | [°C] | [°F] |
| T6...T2 | -40 | -40 | -40 | -40 | -40 | -40 | -40 ① | -40 ① |
| | -39 | -38 | -36 | -32 | -37 | -34 | -50 ① | -58 ① |

① Make sure that gasket temperature is in the specified limits. For more data, refer to the handbook.

Remote (Field) versions (probe housing only)

Equipment category 1/2 G or EPL Ga/Gb: Ex ia and Ex db ia devices

| Temperature class | Maximum ambient temperature | | | | | | Max. flange temperature | |
|-------------------|--|------|--|------|-----------------------|------|-------------------------|------|
| | Ø2 mm / Ø0.08" single cable probe (HT version) | | Ø2 mm / Ø0.08" single cable probe (other versions) | | All other probe types | | | |
| | [°C] | [°F] | [°C] | [°F] | [°C] | [°F] | [°C] | [°F] |
| T6 | +51 | +123 | +49 | +120 | +49 | +120 | +60 | +140 |
| T5 | +70 | +158 | +70 | +158 | +70 | +158 | +60 | +140 |
| T4 | +80 | +176 | +80 | +176 | +80 | +176 | +60 | +140 |

| Temperature class | Minimum ambient temperature | | | | | | Min. flange temperature | |
|-------------------|--|------|--|------|-----------------------|------|-------------------------|------|
| | Ø2 mm / Ø0.08" single cable probe (HT version) | | Ø2 mm / Ø0.08" single cable probe (other versions) | | All other probe types | | | |
| | [°C] | [°F] | [°C] | [°F] | [°C] | [°F] | [°C] | [°F] |
| T6...T2 | -40 | -40 | -40 | -40 | -40 | -40 | -20 | -4 |



INFORMATION!

Remote converter

The maximum ambient temperature, T_a , permitted depends on the temperature class:

- $T_a = +60^\circ\text{C}$ for class T6
- $T_a = +70^\circ\text{C}$ for class T5
- $T_a = +80^\circ\text{C}$ for class T4

Remote (Field) version (probe housing only)

Equipment category 2 G or EPL Gb: Ex ia and Ex ia/db devices

Equipment category 3 G or EPL Gc: Ex ic devices

| Temperature class | Maximum ambient temperature | | | | | | Max. flange temperature | |
|-------------------|--|------|--|------|-----------------------|------|-------------------------|--------|
| | Ø2 mm / Ø0.08" single cable probe (HT version) | | Ø2 mm / Ø0.08" single cable probe (other versions) | | All other probe types | | | |
| | [°C] | [°F] | [°C] | [°F] | [°C] | [°F] | [°C] | [°F] |
| T6 | +51 | +123 | +49 | +120 | +49 | +120 | +60 | +140 |
| | +48 | +118 | +39 | +102 | +43 | +109 | +85 | +185 |
| T5 | +66 | +150 | +64 | +147 | +64 | +147 | +75 | +167 |
| | +65 | +149 | +54 | +129 | +58 | +136 | +100 | +212 |
| T4 | +79 | +174 | +77 | +170 | +78 | +176 | +85 | +185 |
| | +75 | +167 | +64 | +147 | +68 | +154 | +110 | +230 |
| | +71 | +160 | +51 | +124 | +59 | +138 | +135 | +275 |
| T3 | +69 | +156 | +43 | +109 | +54 | +129 | +150 | +302 |
| | +65 | +149 | - | - | - | - | +180 ① | +356 ① |
| | +62 | +143 | - | - | - | - | +200 ① | +392 ① |
| T2 | +54 | +129 | - | - | - | - | +250 ① | +482 ① |
| | +47 | +116 | - | - | - | - | +300 ① | +572 ① |

① Make sure that gasket temperature is in the specified limits. For more data, refer to the handbook.

| Temperature class | Minimum ambient temperature | | | | | | Min. flange temperature | |
|-------------------|--|------|--|------|-----------------------|------|-------------------------|-------|
| | Ø2 mm / Ø0.08" single cable probe (HT version) | | Ø2 mm / Ø0.08" single cable probe (other versions) | | All other probe types | | | |
| | [°C] | [°F] | [°C] | [°F] | [°C] | [°F] | [°C] | [°F] |
| T6...T2 | -40 | -40 | -40 | -40 | -40 | -40 | -40 ① | -40 ① |
| | -39 | -38 | -35 | -31 | -36 | -32 | -50 ① | -58 ① |

① Make sure that gasket temperature is in the specified limits. For more data, refer to the handbook.



INFORMATION!

Remote converter

The maximum ambient temperature, T_a , permitted depends on the temperature class:

- $T_a = +60^\circ\text{C}$ for class T6
- $T_a = +70^\circ\text{C}$ for class T5
- $T_a = +80^\circ\text{C}$ for class T4

2.2.2 Maximum surface temperature of the housing for dust applications



WARNING!

Equipment category 1/2 D, 2 D, 3 D or EPL Da/Db, Db, Dc: Ex ia, Ex ia/tb, Ex ia tb and Ex ic devices only

If the ambient and flange temperatures of the device are not more than values given in the table for Ex ia, Ex ia/tb, Ex ia tb and Ex ic devices, the surface temperature of the housing (compact or remote version) will not be more than +90°C / +194°F. In these conditions, the maximum surface temperature of other parts (process connection etc.) can be more than the maximum housing surface temperature, but it will not be more than the process temperature.

For more data, refer to the table for Ex ia, Ex ia tb, Ex ia/tb, and Ex ic devices in the "Ambient and flange temperature" section.

2.2.3 Process pressure

| Equipment category and Equipment protection level (EPL) | Allowable process pressure | |
|---|----------------------------|----------------------|
| | [kPa] | [psi] |
| 1/2 G or Ga/Gb | 80...110 | 11.6...16 |
| Others | As per non-Ex device | As per non-Ex device |

3 Electrical connections

3.1 General notes



WARNING!

- De-energize the circuit.
- Use the applicable cable glands for the cable entry openings in the housing (M20×1.5 or ½ NPT). For the cable entry size, refer to the device nameplate.
- If ambient temperature >65°C / >149°F, use heat-resistant cables, cable glands and cable entry plugs certified for continuous operation above +80°C / +176°F.

3.2 Terminal compartment

3.2.1 How to open the terminal compartment



WARNING!

If dirt collects on the housing, clean the device with a damp cloth before you remove the terminal compartment cover.

How to open the Ex i terminal compartment

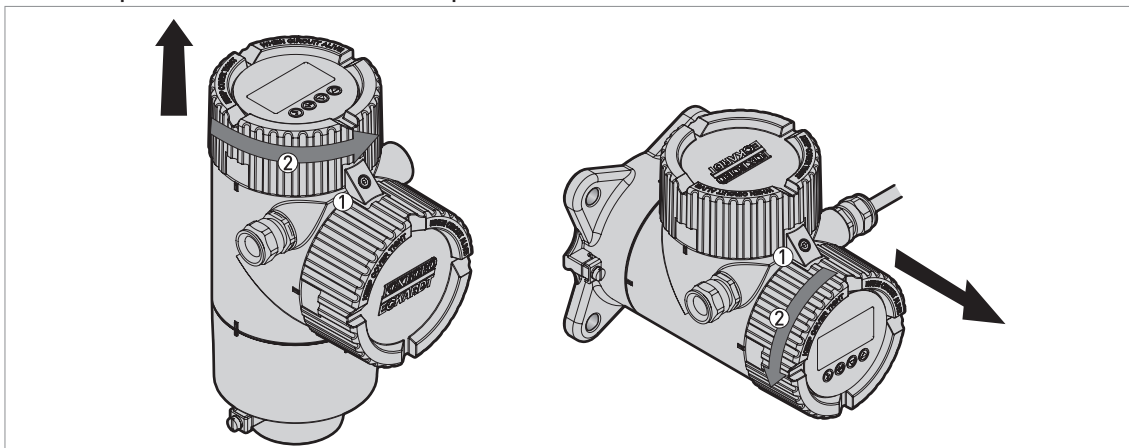

Figure 3-1: How to open the Ex i terminal compartment

How to open the Ex d / Ex t terminal compartment

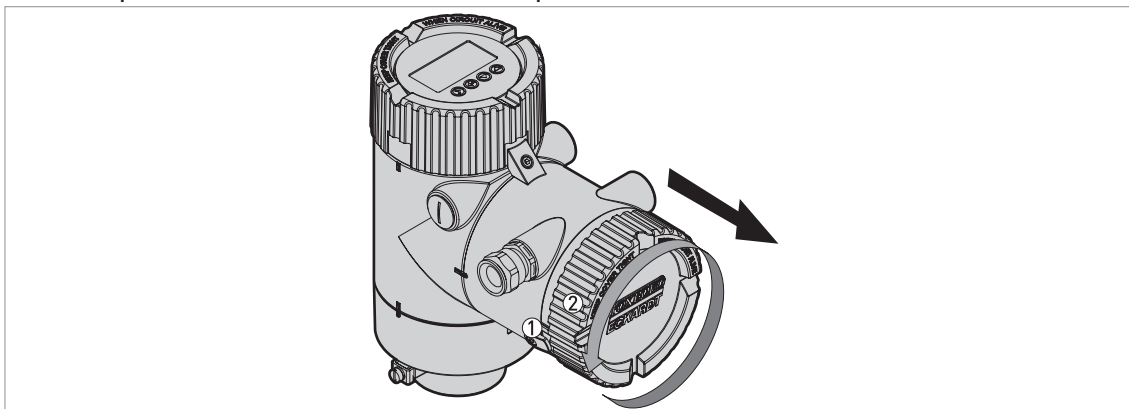

Figure 3-2: How to open the Ex d / Ex t terminal compartment

- ① Cover stop
- ② Terminal compartment cover

Equipment needed (not supplied)

- For Ex i-approved devices: 3 mm Allen wrench.
- For Ex d- / Ex t-approved devices: 2.5 mm Allen wrench.



INFORMATION!

Ex i applications

If you remove the terminal compartment cover, the device has a degree of ingress protection IP20.



WARNING!

Ex d / Ex t applications

Do not remove the terminal compartment cover while the electrical power is connected.



- De-energize the circuit.
- **Ex i-approved devices:** Remove the cover stop ①.
 - ➡ Use a 3 mm Allen wrench.
- **Ex d- / Ex t-approved devices:** After the time given in the table that follows, remove the cover stop ①.
 - ➡ Use a 2.5 mm Allen wrench.
- Remove the terminal compartment cover ②.

| Temperature class | Waiting time before opening |
|-------------------|-----------------------------|
| | [minutes] |
| T6, T5 | 10 |
| T4, T3, T2 | Not necessary |

3.2.2 How to close the terminal compartment



Ex i applications

- Attach the terminal compartment cover ②. Turn the terminal compartment cover carefully to prevent damage to the thread and the gasket.
- Make sure that the terminal compartment cover is tight.
- Use a 3 mm Allen wrench to attach the cover stop ①.
- Make sure that the cover stop ① screw is tight.



DANGER!

Ex d / Ex t applications

Make sure that the terminal compartment is correctly sealed. An explosion can cause death or injury to personnel and/or damage to equipment. Obey the instructions that follow:



Ex d / Ex t applications

- Attach the terminal compartment cover ②. Turn the terminal compartment cover carefully to prevent damage to the thread and the gasket.
- Make sure that the terminal compartment cover is tight.
- Use a 2.5 mm Allen wrench to attach the cover stop ①.
- Make sure that the cover stop ① screw is tight.

3.3 Terminal tightening capacity

The terminal tightening capacity for the current output terminal and the signal cable is:

| Output option | Type of wire | Terminal tightening capacity | |
|-------------------------------------|--------------|------------------------------|-------|
| | | [mm ²] | [AWG] |
| 4...20 mA + HART | Rigid | 2.5 | 13 |
| | Flexible | 2.5 | 13 |
| PROFIBUS PA or FOUNDATION™ fieldbus | Rigid | 3.3 | 12 |
| | Flexible | 3.3 | 12 |

3.4 Equipotential bonding system

Compact version

There is a terminal at the bottom of the converter that can be used as an equipotential bonding conductor. Connect the device to the equipotential bonding system for the hazardous location.

Remote (Field) version

There is a terminal on the wall support and a terminal at the bottom of the probe housing that can be used as equipotential bonding conductors. Connect the device to the equipotential bonding system for the hazardous location.

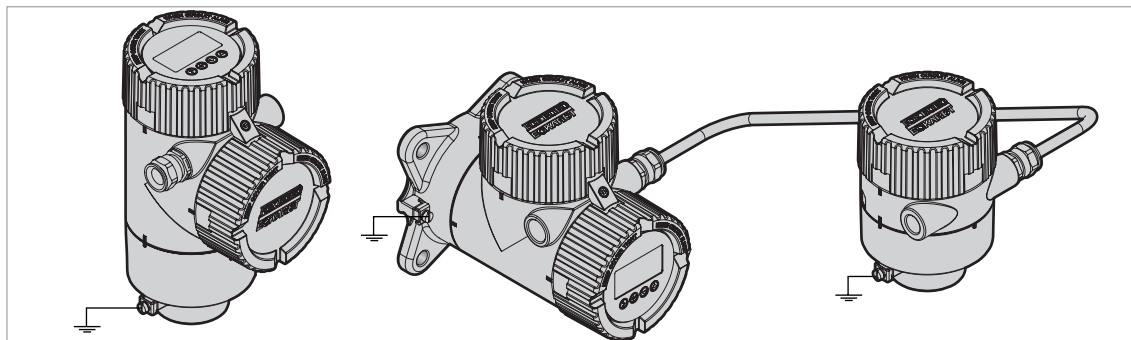

Figure 3-3: Ex i applications: Terminals for the equipotential bonding system

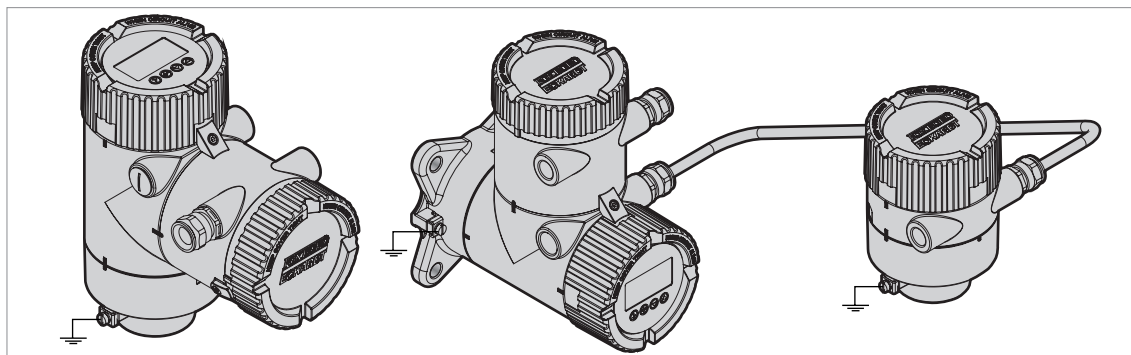

Figure 3-4: Ex d / Ex t applications: Terminals for the equipotential bonding system

3.5 Ex ia equipment

3.5.1 How to connect the electrical cables

Refer to the handbook for data about the device terminals.

Cable glands are supplied on customer demand. If you supply the cable glands, this part must have a degree of ingress protection $IP \geq 6X$ (EN 60529). We recommend that you use a part that has a degree of ingress protection $IP \geq 66$. Make sure that the cable gland is sealed.



Obey the instructions that follow:

- Electrical wires must agree with applicable standards (e.g. EN 60079-14).
- Use the electrical connection procedure in the Handbook.
- Put the electrical wires in position and safely attach them to prevent damage. The electrical wires must also be a sufficient distance from hot surfaces.
- Make sure that unused electrical wires are safely connected to the ground potential of the hazardous area. If this is not possible, make sure that each of the unused electrical wires are safely isolated (other electrical wires, ground etc.) and rated for a test voltage $\geq 500 V_{RMS}$.
- If it is necessary, make sure the electrical wire insulation gives good protection from corrosion.
- Connect only to separate certified, intrinsically-safe circuits. Make sure that the electrical circuit characteristics are not more than the values that follow.
- Do not remove more than 6 mm / 0.2" of insulation from the wire.

3.5.2 Maximum intrinsically-safe values for the electrical circuit

| Output option | | Intrinsically-safe values for the electrical circuit | | | | |
|-------------------------------------|--------|--|------------|-------------|--------|------------|
| | | U_i | I_i | P_i | C_i | L_i |
| | | [V] | [mA] | [W] | [nF] | [μ H] |
| 4...20 mA passive - HART | | ≤ 30 | ≤ 300 | ≤ 1 | $= 16$ | $= 27$ |
| PROFIBUS PA FOUNDATION™ fieldbus | Entity | ≤ 24 | ≤ 300 | ≤ 1.2 | $= 1$ | $= 2$ |
| | FISCO | ≤ 17.5 | ≤ 380 | ≤ 5.32 | $= 1$ | $= 2$ |

3.5.3 Supply voltage

Level transmitter with the 4...20 mA output option

| | Minimum voltage at output terminals [V DC] | Maximum voltage at output terminals [V DC] |
|--------------------------|--|--|
| Current output terminals | 11.5 ① | 30 ① |

① For a current output of 22 mA

Level transmitter with the PROFIBUS PA or FOUNDATION fieldbus output option

| | | Minimum voltage at output terminals [V DC] | Maximum voltage at output terminals [V DC] |
|------------------|--------|--|--|
| Output terminals | Entity | 9 | 24 |
| | FISCO | 9 | 17.5 |

3.5.4 Electrical schematic

Level transmitter with the 4...20 mA passive – HART output option

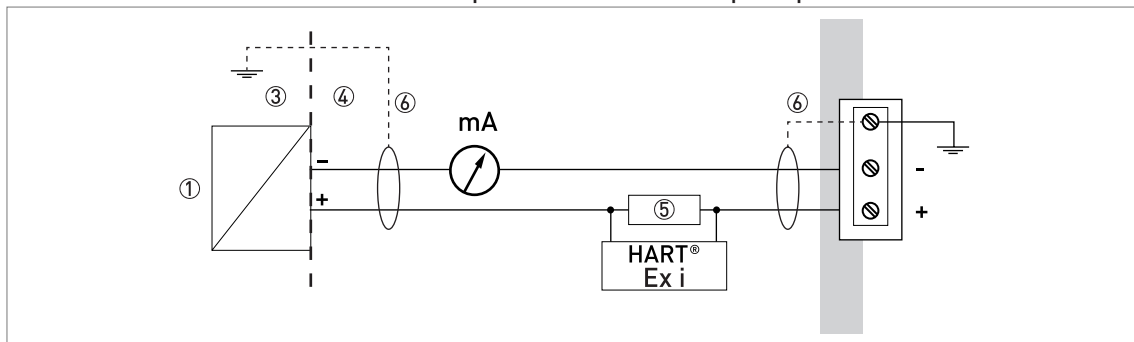

Figure 3-5: Electrical schematic for Ex ia-approved equipment with the 4...20 mA passive – HART output option

Level transmitter with the FOUNDATION™ fieldbus or PROFIBUS PA output option

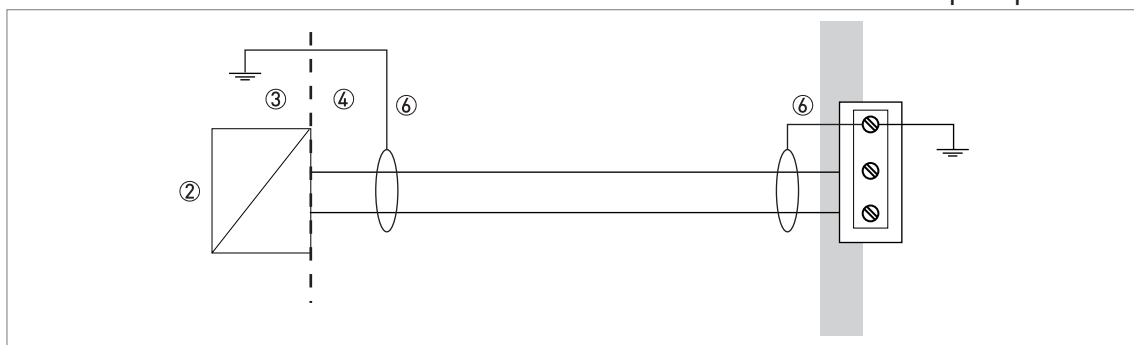

Figure 3-6: Electrical schematic for Ex ia-approved equipment with the FOUNDATION™ fieldbus or PROFIBUS PA output option

- ① Intrinsically-safe power supply
- ② Approved barrier with entity parameters or FISCO power supply
- ③ Non-Ex zone
- ④ Ex zone
- ⑤ Resistor for HART® communication
- ⑥ Grounding wire – if the electrical cable is shielded (braided wire etc.). NOTE: Shielded electrical cable is mandatory for fieldbus output options.

Remote (Field) version

The signal cable (between the converter electronics and the probe electronics) is supplied by the manufacturer for ATEX applications. The signal cable cannot be changed by the user. For more data, speak to the supplier.

3.6 Ex ia/db, Ex db ia, Ex ia/tb and Ex ia tb equipment

3.6.1 General notes

Ex ia/db-, Ex db ia-, Ex ia/tb- and Ex ia tb-approved equipment have two separate compartments. The electronics in the electronics block compartment are Ex ia-approved and the terminals compartment is Ex d / Ex t-approved.

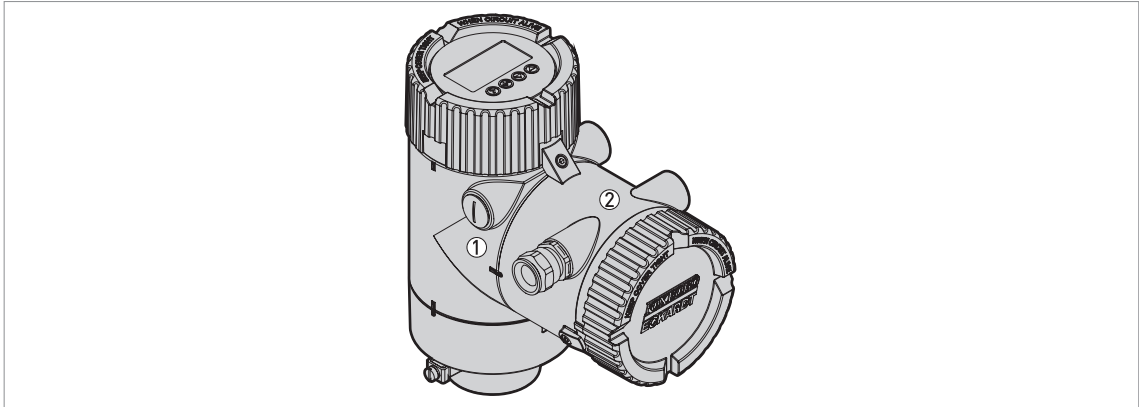

Figure 3-7: Compact version: Compartments in Ex ia/db-, Ex db ia-, Ex ia/tb- and Ex ia tb-approved equipment

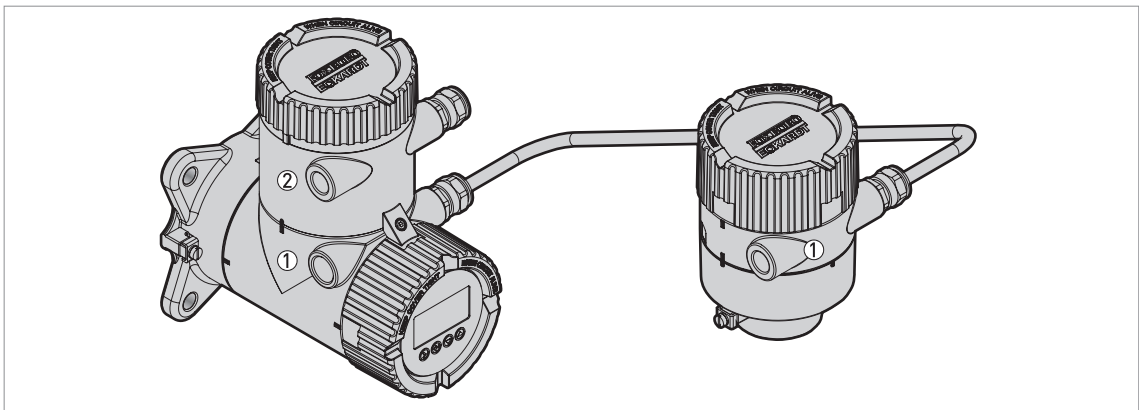

Figure 3-8: Remote (Field) version: Compartments in Ex db ia- and Ex ia tb-approved equipment

- ① Electronics block (Ex ia) compartment
- ② Terminal (Ex d / Ex t) compartment



INFORMATION!

The flamepath dimensions are better than the values specified in the European Standard EN 60079-1 (minimum length 13.9 mm and maximum gap 118 µm).

3.6.2 How to connect the electrical cables

Cable glands are supplied on customer demand. If you supply the cable glands, this part must have a degree of ingress protection IP \geq 6X (EN 60529).



WARNING!

Use only Ex d-approved cable glands and plugs for Ex d applications. Use only Ex t-approved cable glands and plugs for Ex t applications.

Do not remove more than 6 mm / 0.2" of insulation from the wire.



- Do not remove more than 6 mm / 0.2" of insulation from the wire.
- Connect the load resistor to the positive terminal of the power supply
- Ground the negative connection.
- If the load resistor has to be connected to the negative terminal, the loop resistance must not be more than 350 ohms.

**CAUTION!**

4...20 mA passive - HART output option: Do not ground the positive connection.

3.6.3 Supply voltage

**INFORMATION!**

For maximum intrinsically-safe values, refer to Maximum intrinsically-safe values for the electrical circuit on page 20.

Level transmitter with the 4...20 mA output option

| | Minimum voltage at output terminals [V DC] | Maximum voltage at output terminals [V DC] |
|--------------------------|--|--|
| Current output terminals | 13.5 ① | 36 ① |

① For a current output of 22 mA

Level transmitter with the PROFIBUS PA or FOUNDATION fieldbus output option

| | | Minimum voltage at output terminals [V DC] | Maximum voltage at output terminals [V DC] |
|------------------|--------|--|--|
| Output terminals | Entity | 9 | 24 |
| | FISCO | 9 | 17.5 |

For more data, refer to *Maximum intrinsically-safe values for the electrical circuit* on page 20.

3.6.4 Electrical schematic



DANGER!
Keep the grounding wire a minimum distance of 2 mm / 0.83" away from the output terminal.



CAUTION!
Make sure that you connect the load resistor to the positive side.

Level transmitter with the 4...20 mA passive – HART output option

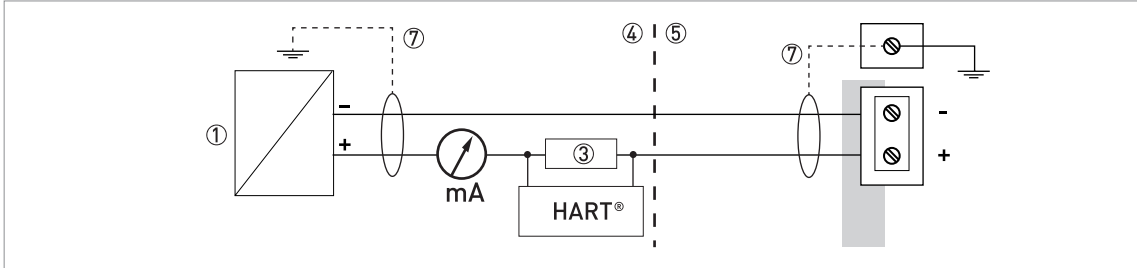

Figure 3-9: Electrical schematic for Ex ia/db / Ex ia tb-approved equipment (with galvanic isolation)

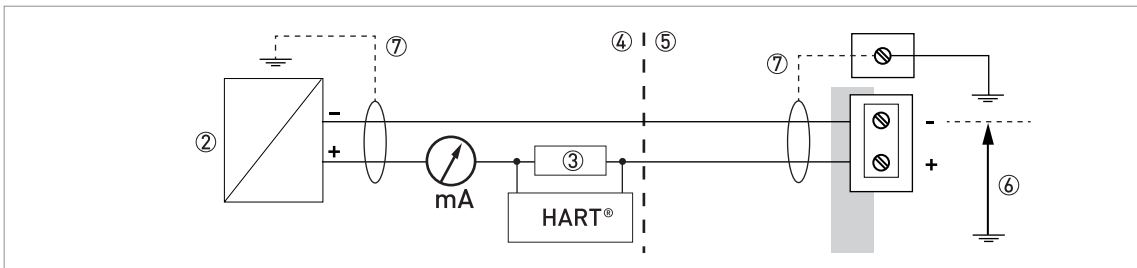

Figure 3-10: Electrical schematic for Ex ia/db / Ex ia tb-approved equipment (without galvanic isolation)

- ① Galvanically-isolated power supply
- ② Power supply
- ③ Resistor for HART® communication
- ④ Non-Ex zone
- ⑤ Ex zone
- ⑥ $|U| < 13\text{ V}$
- ⑦ Grounding wire – if the electrical cable is shielded (braided wire etc.)

Level transmitter with the FOUNDATION™ fieldbus or PROFIBUS PA output option

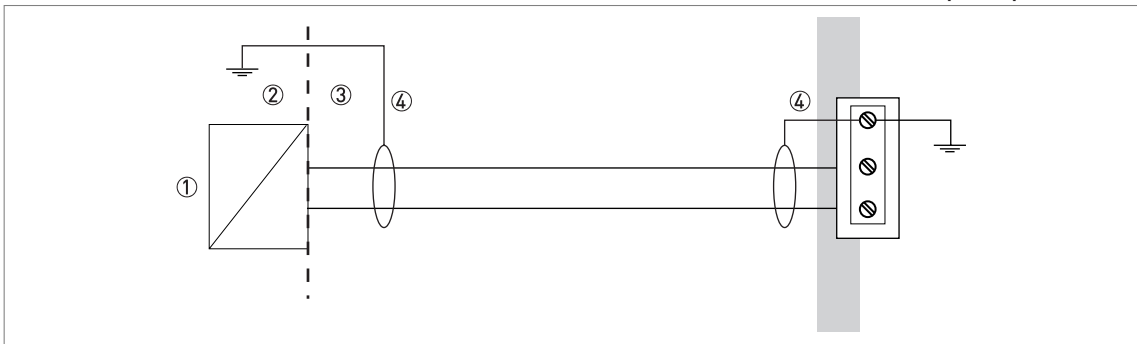

Figure 3-11: Electrical schematic for Ex ia/db / Ex ia tb-approved equipment with the FOUNDATION™ fieldbus or PROFIBUS PA output option

- ① Approved barrier with entity parameters or FISCO power supply. For more data, refer to *Maximum intrinsically-safe values for the electrical circuit* on page 20.
- ② Non-Ex zone
- ③ Ex zone
- ④ Grounding wire. NOTE: Shielded electrical cable is mandatory for fieldbus output options.

Remote (Field) version

The signal cable (between the converter electronics and the probe electronics) is supplied by the manufacturer for ATEX applications. The signal cable cannot be changed by the user. For more data, speak to the supplier.

3.7 Ex ic equipment

3.7.1 How to connect the electrical cables

Refer to the handbook for data about the device terminals.

Cable glands are supplied on customer demand. If you supply the cable glands, this part must have a degree of ingress protection $IP \geq 6X$ (EN 60529). We recommend that you use a part that has a degree of ingress protection $IP \geq 66$. Make sure that the cable gland is sealed.



Obey the instructions that follow:

- Electrical wires must agree with applicable standards (e.g. EN 60079-14).
- Use the electrical connection procedure in the Handbook.
- Put the electrical wires in position and safely attach them to prevent damage. The electrical wires must also be a sufficient distance from hot surfaces.
- Make sure that unused electrical wires are safely connected to the ground potential of the hazardous area. If this is not possible, make sure that each of the unused electrical wires are safely isolated (other electrical wires, ground etc.) and rated for a test voltage $\geq 500 V_{RMS}$.
- If it is necessary, make sure the electrical wire insulation gives good protection from corrosion.
- Connect only to separate certified, intrinsically-safe circuits. Make sure that the electrical circuit characteristics are not more than the values that follow.
- Do not remove more than 6 mm / 0.2" of insulation from the wire.

3.7.2 Maximum intrinsically-safe values for the electrical circuit

| Output option | | Intrinsically-safe values for the electrical circuit | | | | |
|-------------------------------------|--------|--|------------|----------|--------|------------|
| | | U_i | I_i | P_i | C_i | L_i |
| | | [V] | [mA] | [W] | [nF] | [μ H] |
| 4...20 mA passive - HART | | ≤ 30 | ≤ 300 | ≤ 1 | $= 16$ | $= 27$ |
| PROFIBUS PA FOUNDATION™ fieldbus | Entity | ≤ 32 | ① | ① | $= 1$ | $= 2$ |
| | FISCO | ≤ 17.5 | ① | ① | $= 1$ | $= 2$ |

① I_i and P_i values are not applicable.

3.7.3 Supply voltage

Level transmitter with the 4...20 mA output option

| | Minimum voltage at output terminals [V DC] | Maximum voltage at output terminals [V DC] |
|--------------------------|--|--|
| Current output terminals | 11.5 ① | 30 ① |

① For a current output of 22 mA

Level transmitter with the PROFIBUS PA or FOUNDATION fieldbus output option

| | | Minimum voltage at output terminals [V DC] | Maximum voltage at output terminals [V DC] |
|------------------|--------|--|--|
| Output terminals | Entity | 9 | 32 |
| | FISCO | 9 | 17.5 |

3.7.4 Electrical schematic

Level transmitter with the 4...20 mA passive – HART output option

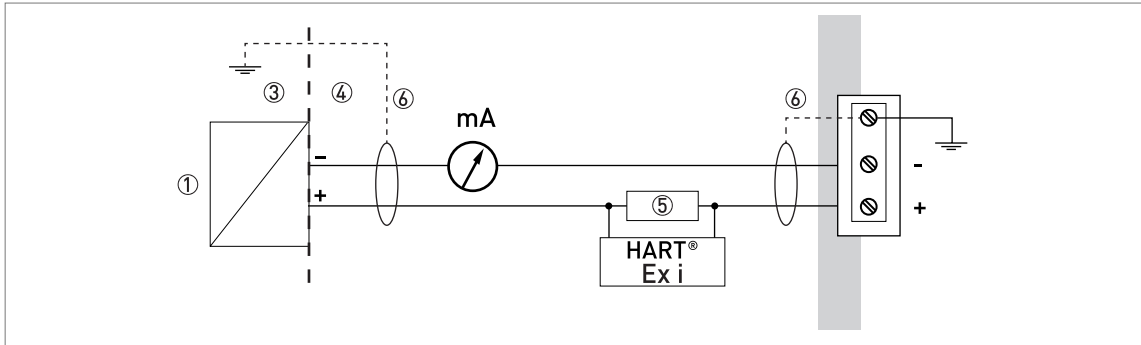

Figure 3-12: Electrical schematic for Ex ic-approved equipment with the 4...20 mA passive – HART output option

Level transmitter with the FOUNDATION™ fieldbus or PROFIBUS PA output option

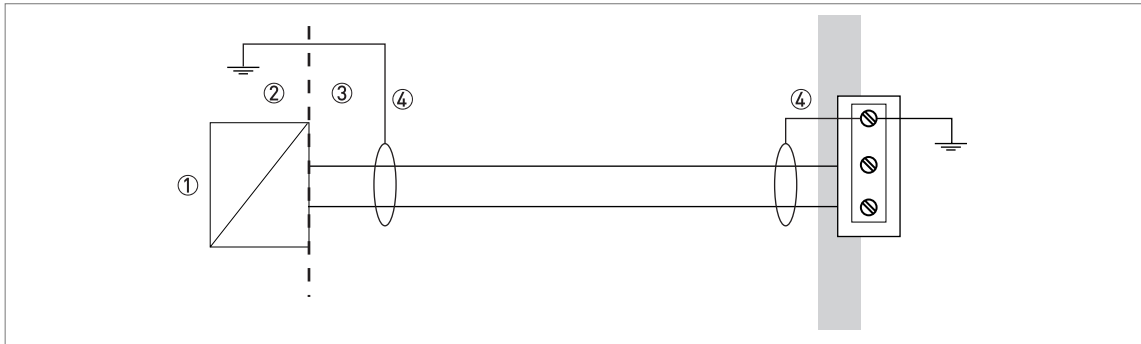

Figure 3-13: Electrical schematic for Ex ic-approved equipment with the FOUNDATION™ fieldbus or PROFIBUS PA output option

- ① Approved barrier with entity parameters or FISCO power supply
- ② Non-Ex zone
- ③ Ex zone
- ④ Grounding wire – if the electrical cable is shielded (braided wire etc.). NOTE: Shielded electrical cable is mandatory for fieldbus output options.

Remote (Field) version

The signal cable (between the converter electronics and the probe electronics) is supplied by the manufacturer for ATEX applications. The signal cable cannot be changed by the user. For more data, speak to the supplier.

4 Start-up



WARNING!

Make sure that it is safe to supply electrical power. Do a start-up check:



- Are the wetted components (gasket, flange and probe) resistant to corrosion by the tank product?
- Does the information given on the nameplate agree with the application?
- Did you connect the equipotential bonding system correctly?
- **Ex d applications:** Are the cable glands, plugs and adaptors Ex d-approved?
- **Ex t applications:** Are the cable glands, plugs and adaptors Ex t-approved?
- **Ex ia applications:** Are you using an intrinsically-safe barrier within the correct parameters? For more data, refer to *Ex ia equipment* on page 20. The electrical circuit characteristics must not be more than the maximum intrinsically-safe values.
- **Ex ic applications:** Are you using an intrinsically-safe barrier within the correct parameters? For more data, refer to *Ex ic equipment* on page 25. The electrical circuit characteristics must not be more than the maximum intrinsically-safe values.
- Did you install the correct cable glands? Is the terminal compartment correctly sealed?

5 Service

5.1 Periodic maintenance

No maintenance is necessary.



INFORMATION!

For more data about regular inspections and maintenance procedures for devices with Ex and other approvals, refer to the related supplementary instructions.

5.2 Keep the device clean



DANGER!

If dirt collects on the device, clean it with a damp cloth.

The device contains a PTFE boundary wall between the process and the signal converter. If the PTFE part is not resistant to corrosion by your cleaning agents, do not clean the device with them.

If you use the incorrect cleaning agent (i.e. the device is not resistant to corrosion by your cleaning agent), do not use the device in a hazardous location. If aid is necessary, speak or write to the supplier.

5.3 Manufacturer

Eckardt S.A.S.
20 rue de la Marne
68360 Soultz
France

If you need to return your device for inspection or repair, speak or write to your supplier and obey the instructions that follow.

5.4 Returning the device to the manufacturer

5.4.1 General information

This device has been carefully manufactured and tested. If installed and operated in accordance with these operating instructions, it will rarely present any problems.



WARNING!

Should you nevertheless need to return a device for inspection or repair, please pay strict attention to the following points:

- *Due to statutory regulations on environmental protection and safeguarding the health and safety of the personnel, the manufacturer may only handle, test and repair returned devices that have been in contact with products without risk to personnel and environment.*
- *This means that the manufacturer can only service this device if it is accompanied by the following certificate (see next section) confirming that the device is safe to handle.*

**WARNING!**

If the device has been operated with toxic, caustic, radioactive, flammable or water-endangering products, you are kindly requested:

- *to check and ensure, if necessary by rinsing or neutralising, that all cavities are free from such dangerous substances,*
- *to enclose a certificate with the device confirming that it is safe to handle and stating the product used.*

5.4.2 Form (for copying) to accompany a returned device

**CAUTION!**

To avoid any risk for our service personnel, this form has to be accessible from outside of the packaging with the returned device.

| | | | |
|---|---|-------------------------------|--|
| Company: | | Address: | |
| Department: | | Name: | |
| Tel. no.: | | Fax no. and/or Email address: | |
| Manufacturer's order no. or serial no.: | | | |
| The device has been operated with the following medium: | | | |
| This medium is: | radioactive | | |
| | water-hazardous | | |
| | toxic | | |
| | caustic | | |
| | flammable | | |
| | We checked that all cavities in the device are free from such substances. | | |
| | We have flushed out and neutralized all cavities in the device. | | |
| We hereby confirm that there is no risk to persons or the environment through any residual media contained in the device when it is returned. | | | |
| Date: | | Signature: | |
| Stamp: | | | |

Schneider Electric Systems USA, Inc.
38 Neponset Avenue
Foxboro, MA 02035
United States of America

schneider-electric.com

Global Customer Support
Toll free: 1-866-746-6477
Global: 1-508-549-2424
Website:
<https://pasupport.schneider-electric.com>

Copyright 2019 Schneider Electric Systems USA, Inc. All rights reserved.
Foxboro and Schneider Electric are trademarks of Schneider Electric Systems USA, Inc., its subsidiaries, and affiliates. All other trademarks are the property of their respective owners.