

Instruction

MI 021-534 en

FEBRUARY 2020

Model 9700A Magnetic Flow Sensor

Quick Start

1	Safety instructions	3
<hr/>		
2	Installation	4
<hr/>		
2.1	Scope of delivery.....	4
2.2	Device description	5
2.3	Nameplate	6
2.4	Storage	6
2.5	Transport	7
2.6	Pre-installation requirements	7
2.7	General requirements	8
2.7.1	Vibrations	8
2.7.2	Magnetic field.....	8
2.8	Installation conditions	9
2.8.1	Inlet and outlet	9
2.8.2	Bends in 2 or 3 dimensions.....	9
2.8.3	T-section	10
2.8.4	Bends	10
2.8.5	Open discharge	11
2.8.6	Pump	11
2.8.7	Control valve	11
2.8.8	Air venting and vacuum forces	12
2.8.9	Flange deviation.....	13
2.8.10	Mounting position.....	13
2.9	Mounting.....	14
2.9.1	Torques and pressures.....	14
2.9.2	Temperatures	17
<hr/>		
3	Electrical connections	18
<hr/>		
3.1	Safety instructions.....	18
3.2	Grounding	18
3.3	Virtual reference for IMT33A (4, N and H version).....	20
3.4	Connection diagrams	20
<hr/>		
4	Technical data	21
<hr/>		
4.1	Dimensions and weights	21
4.2	Vacuum load	26
<hr/>		
5	Notes	27
<hr/>		

Warnings and symbols used



DANGER!

This information refers to the immediate danger when working with electricity.



DANGER!

These warnings must be observed without fail. Even partial disregard of this warning can lead to serious health problems and even death.



WARNING!

Disregarding this safety warning, even if only in part, poses the risk of serious health problems. There is also the risk of damaging the device or parts of the operator's plant.



CAUTION!

Disregarding these instructions can result in damage to the device or to parts of the operator's plant.



NOTICE!

These instructions contain important information for the handling of the device.



HANDLING

- This symbol designates all instructions for actions to be carried out by the operator in the specified sequence.

➔ **RESULT**

This symbol refers to all important consequences of the previous actions.

Safety instructions for the operator



CAUTION!

Installation, assembly, start-up and maintenance may only be performed by appropriately trained personnel. The regional occupational health and safety directives must always be observed.



LEGAL NOTICE!

The responsibility as to the suitability and intended use of this device rests solely with the user. The supplier assumes no responsibility in the event of improper use by the customer. Improper installation and operation may lead to loss of warranty. In addition, the "Terms and Conditions of Sale" apply which form the basis of the purchase contract.



NOTICE!

Further information can be found on the website.

2.1 Scope of delivery

**NOTICE!**

Do a check of the packing list to make sure that you have all the elements given in the order.

**NOTICE!**

Inspect the packaging carefully for damages or signs of rough handling. Report damage to the carrier and to the local office of the manufacturer.

**NOTICE!**

The remote version will arrive in two cartons. One carton contains the signal transmitter and one carton contains the flow tube.

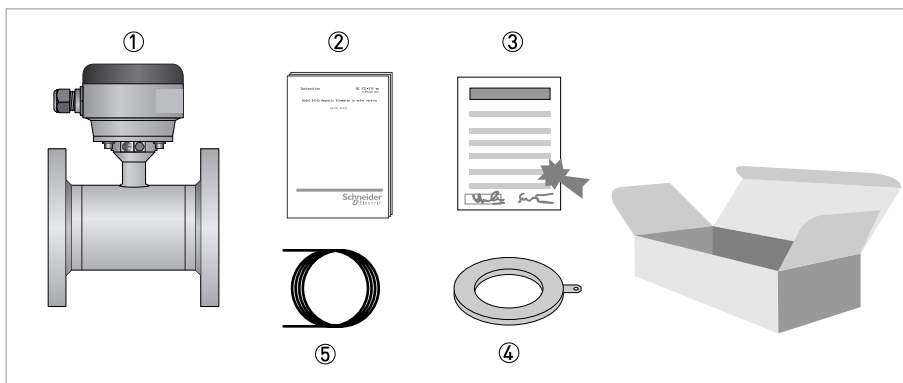

Figure 2-1: Scope of delivery

- ① Ordered flowmeter
- ② Product documentation
- ③ Factory calibration report
- ④ Grounding rings (optional)
- ⑤ Signal cable (remote versions only)

**NOTICE!**

Assembly materials and tools are not part of the delivery. Use the assembly materials and tools in compliance with the applicable occupational health and safety directives.

2.2 Device description

Electromagnetic flowmeters are designed exclusively to measure the flow and conductivity of electrically conductive, liquid media.

Your measuring device is supplied ready for operation. The factory settings for the operating data have been made in accordance with your order specifications.

The following versions are available:

- Compact version (the signal converter is mounted directly on the flow sensor)
- Remote version (electrical connection to the flow sensor via field current and signal cable)

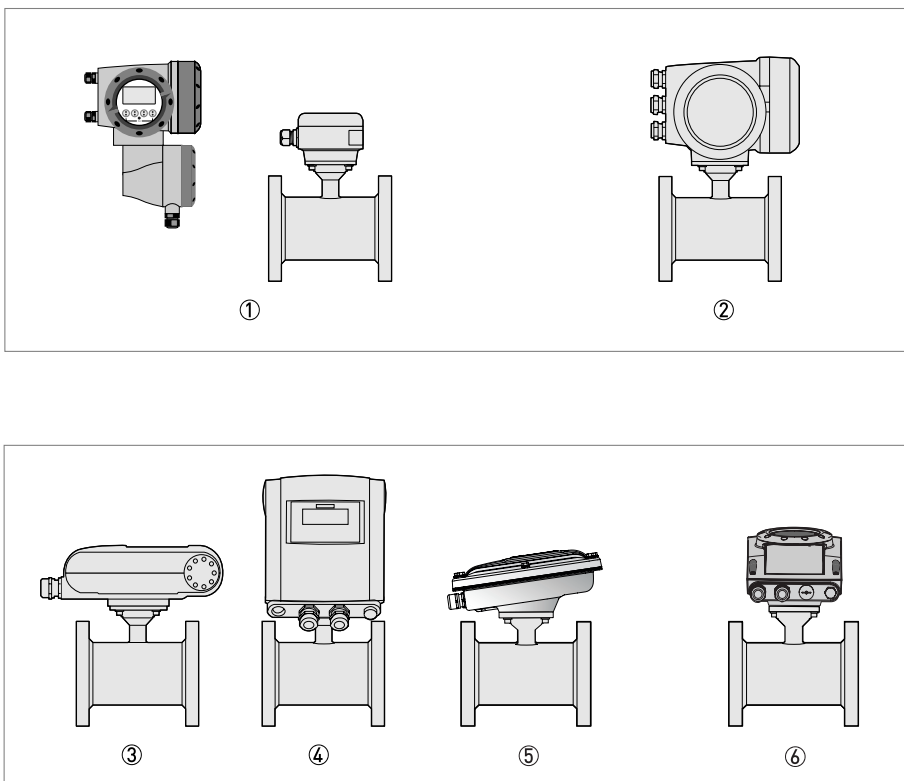

Figure 2-2: Device versions

- ① Remote version
- ② Compact version with signal transmitter IMT33A
- ③ Compact version with signal transmitter IMT31A (0°)
- ④ Compact version with signal transmitter IMT31A (45°)
- ⑤ Compact version with stainless steel signal transmitter IMT31A (10°)
- ⑥ Compact version with signal transmitter IMT30A (10°)

2.3 Nameplate



NOTICE!

Check the device nameplate to ensure that the device is delivered according to your order. Additional information (e.g. correct supply voltage), can be found in the documentation of the transmitter.

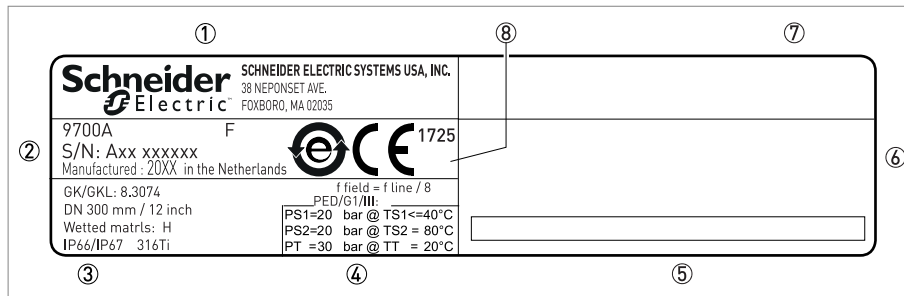

- ① Name and address of the manufacturer
- ② Type designation of the flowmeter, serial number and manufacturing date
- ③ Calibration data
- ④ PED data
- ⑤ Tag number
- ⑥ Additional information
- ⑦ Applicable product certification marking
- ⑧ CE sign with number(s) of notified body/bodies and Disposal logo

2.4 Storage

- Store the device in a dry and dust-free location.
- Avoid lasting direct exposure to the sun.
- Store the device in its original packaging.
- Storage temperature: -50...+70°C / -58...+158°F

2.5 Transport

Signal converter

- No special requirements.

Compact version

- Do not lift the device by the signal converter housing.
- Do not use lifting chains.
- To transport flange devices, use lifting straps. Wrap these around both process connections.

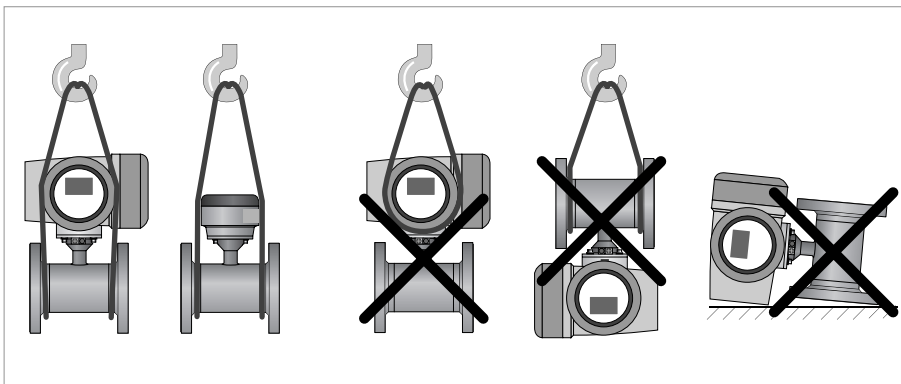

Figure 2-3: Transport

2.6 Pre-installation requirements

Make sure that you have all necessary tools available:

- Allen key (4 mm)
- Small screwdriver
- Wrench for cable glands
- Wrench for wall mounting bracket (remote version only)
- Torque wrench for installing flowmeter in pipeline

2.7 General requirements

**NOTICE!**

The following precautions must be taken to ensure reliable installation.

- Make sure that there is adequate space to the sides.
- Protect the transmitter from direct sunlight and install a sun shade if necessary.
- Transmitters installed in control cabinets require adequate cooling, e.g. by fan or heat exchanger.
- Do not expose the transmitter to intense vibration. The flowmeters are tested for a vibration level in accordance with IEC 60068-2-64.
- Avoid magnetic field! Keep at least 5 DN distance between electromagnetic flow tubes.

2.7.1 Vibrations

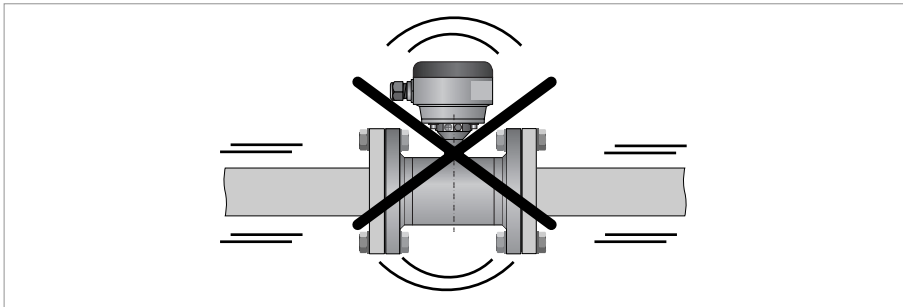

Figure 2-4: Avoid vibrations

2.7.2 Magnetic field

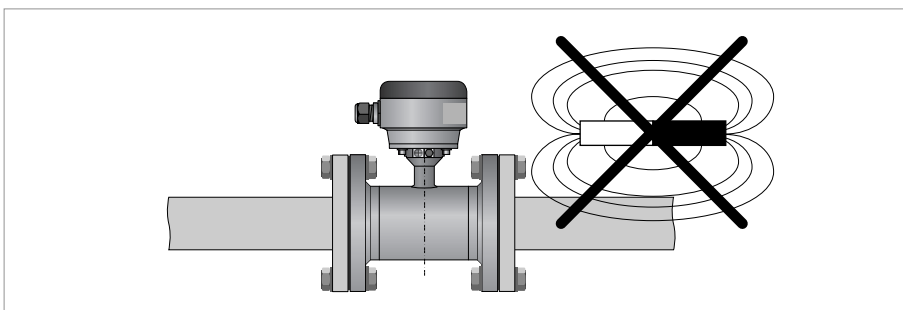

Figure 2-5: Avoid magnetic field

2.8 Installation conditions

2.8.1 Inlet and outlet

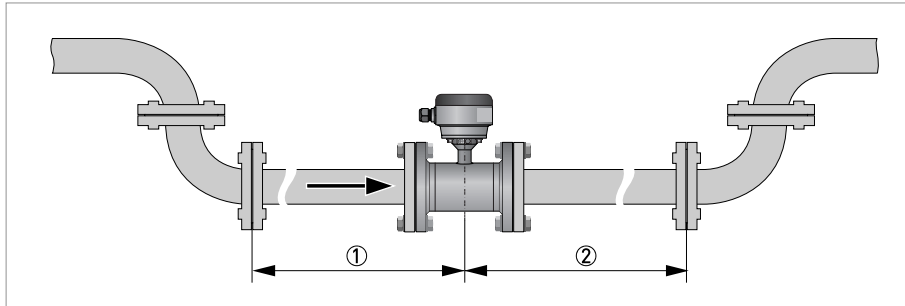

Figure 2-6: Recommended inlet and outlet

- ① Refer to chapter "Bends in 2 or 3 dimensions"
- ② ≥ 2 DN



NOTICE!

9700A flow tube up to DN10 - 3/8":

The inlet and outlet sections are enclosed inside the tube.

2.8.2 Bends in 2 or 3 dimensions

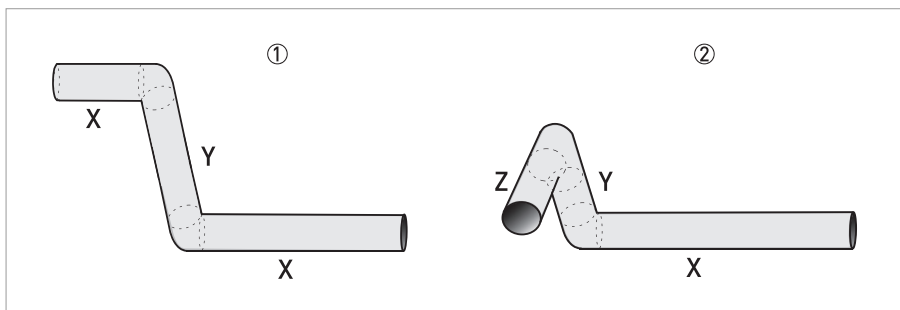

Figure 2-7: 2 and/or 3 dimensional bends upstream of the flowmeter

- ① 2 dimensions = X/Y
 - ② 3 dimensions = X/Y/Z
- Inlet length: using bends in 2 dimensions: ≥ 5 DN; when having bends in 3 dimensions: ≥ 10 DN



NOTICE!

2 dimensional bends occur in a vertical **or** horizontal plane (X/Y) only, while 3 dimensional bends occur in both vertical **and** horizontal plane (X/Y/Z).

2.8.3 T-section

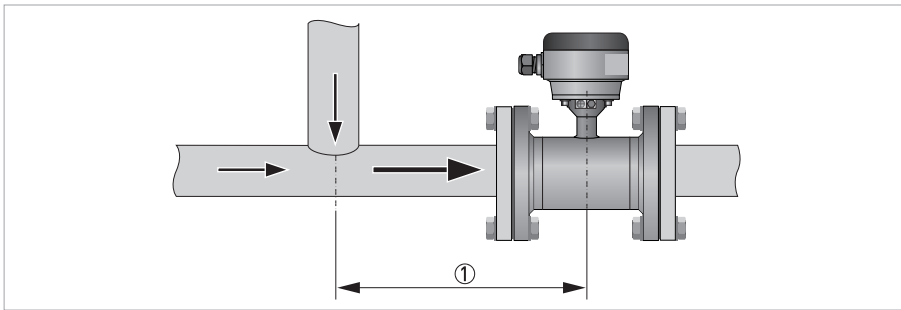

Figure 2-8: Distance behind a T-section

① ≥ 10 DN

2.8.4 Bends

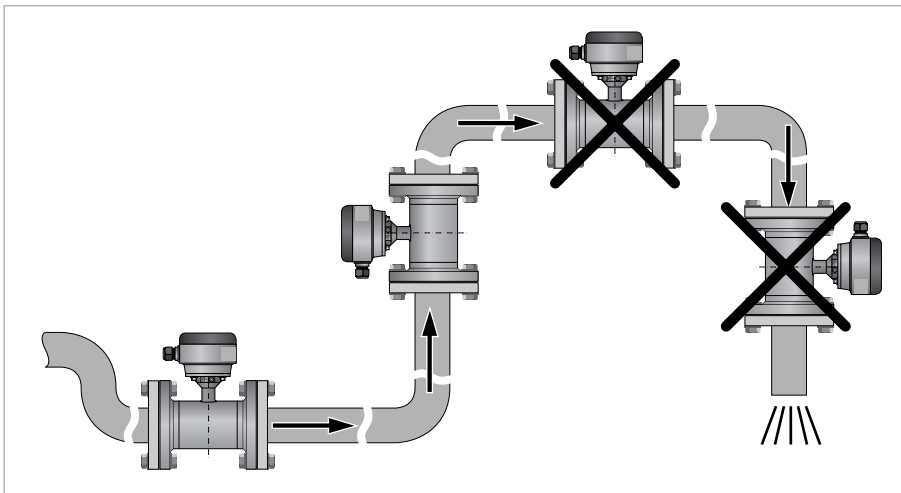

Figure 2-9: Installation in bending pipes (90°)

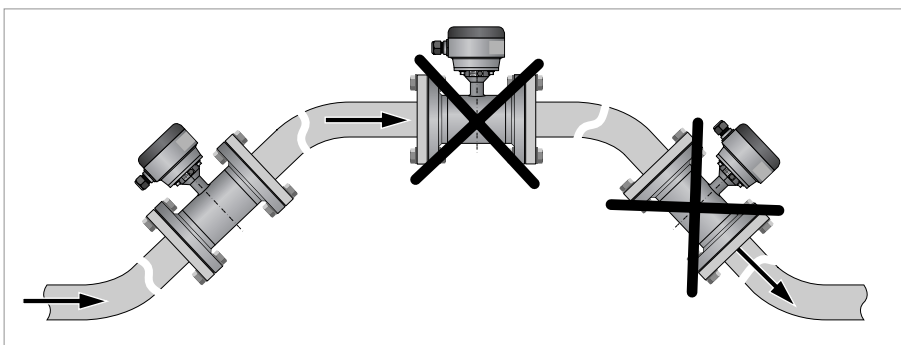

Figure 2-10: Installation in bending pipes (45°)



CAUTION!

Avoid draining or partial filling of the flow tube

2.8.5 Open discharge

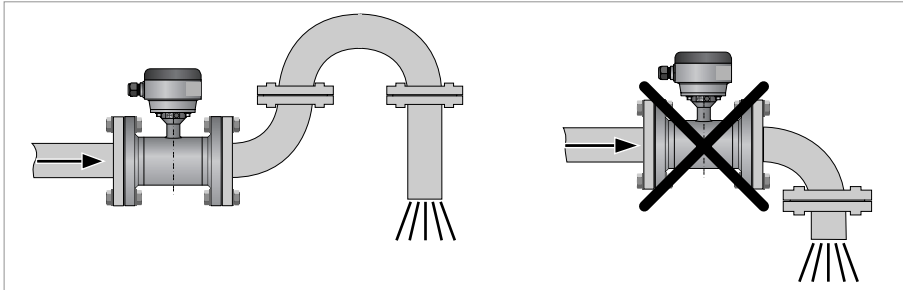

Figure 2-11: Installation in front of an open discharge

2.8.6 Pump

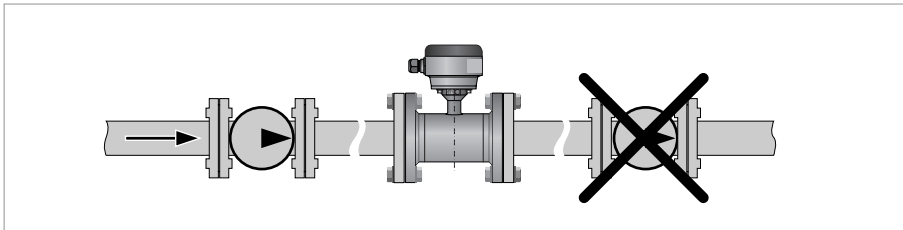

Figure 2-12: Installation behind a pump

2.8.7 Control valve

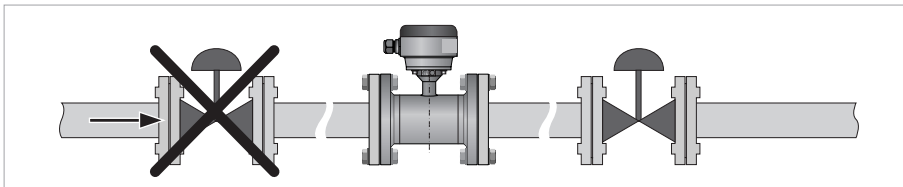

Figure 2-13: Installation in front of a control valve

2.8.8 Air venting and vacuum forces

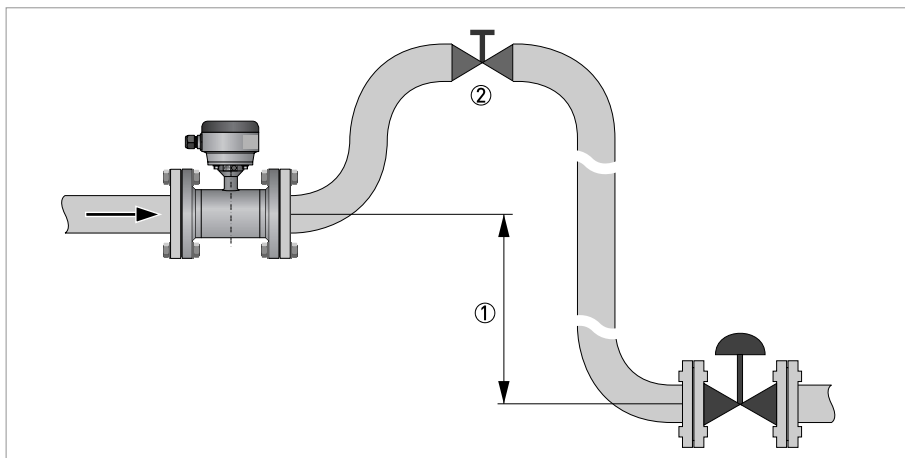

Figure 2-14: Air venting

- ① ≥ 5 m / 17 ft
- ② Air ventilation point

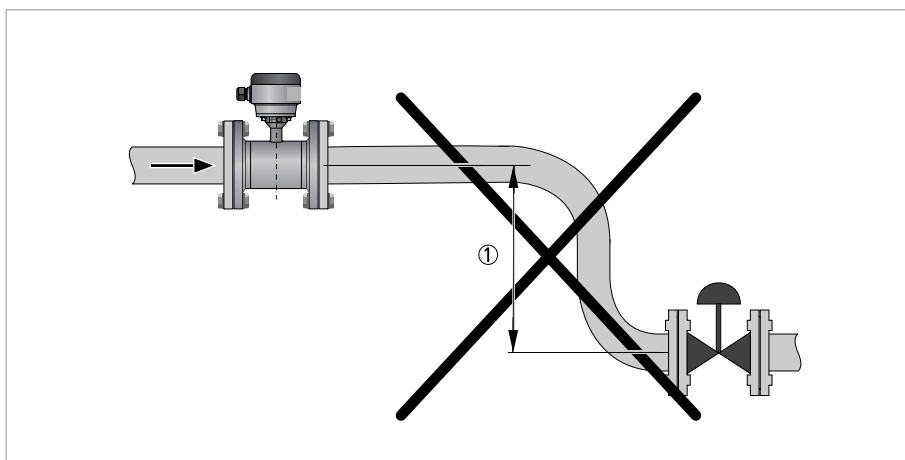

Figure 2-15: Vacuum

- ① ≥ 5 m / 17 ft

2.8.9 Flange deviation



CAUTION!

Max. permissible deviation of pipe flange faces:
 $L_{max} - L_{min} \leq 0.5 \text{ mm} / 0.02''$

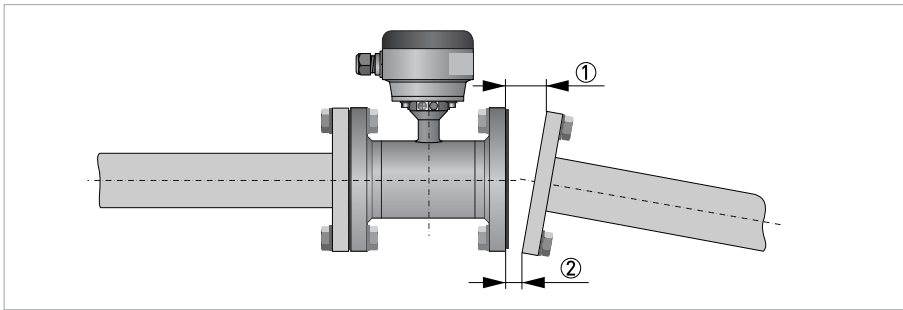

Figure 2-16: Flange deviation

- ① L_{max}
- ② L_{min}

2.8.10 Mounting position

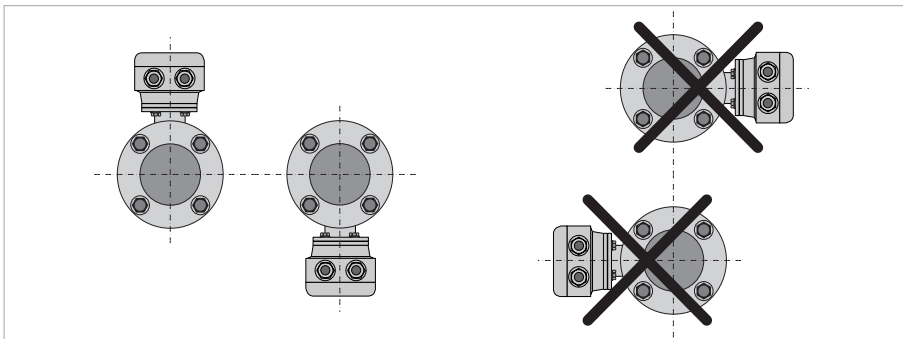

Figure 2-17: Mounting position

- Install flow tube in line with the pipe axis.
- Pipe flange faces must be parallel to each other.

2.9 Mounting

**CAUTION!**

Please take care to use the proper gasket to prevent damaging the liner of the flowmeter. In general, the use of spiral wound gaskets is not advised, as it could severely damage the liner of the flowmeter.

2.9.1 Torques and pressures

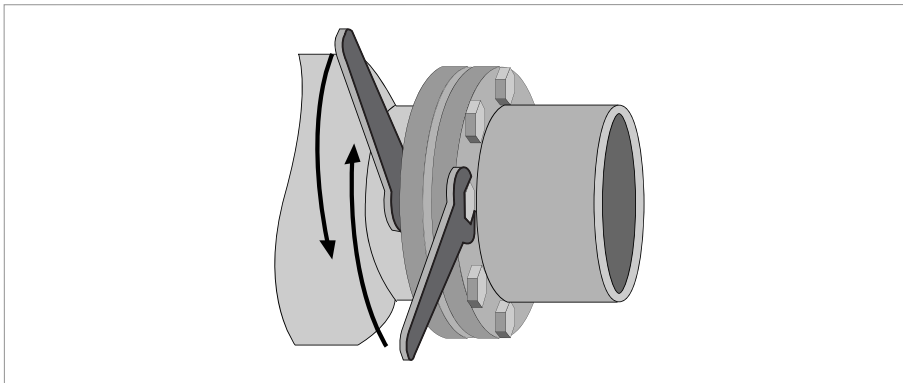

Figure 2-18: Tightening of bolts



Tightening of bolts

- Always tighten the bolts uniformly and in diagonally opposite sequence.
- Do not exceed the maximum torque value.
- Step 1: Apply approx. 50% of max. torque given in table.
- Step 2: Apply approx. 80% of max. torque given in table.
- Step 3: Apply 100% of max. torque given in table.

**NOTICE!**

Other sizes / pressure ratings on request.

Nominal size DN [mm]	Pressure rating	Bolts ②	Max. torque [Nm] ①				
			PFA	PTFE	ETFE	PU	Soft rubber
2.5	PN 40	4 x M 12		32	-	-	-
4	PN 40	4 x M 12		32	-	-	-
6	PN 40	4 x M 12		32	-	-	-
10	PN 40	4 x M 12	7.6	7.6	-	4.6	-
15	PN 40	4 x M 12	9.3	9.3	-	5.7	-
20	PN 40	4 x M 12	16	16	-	9.6	-
25	PN 40	4 x M 12	22	22	22	11	-
32	PN 40	4 x M 16	37	37	37	19	-
40	PN 40	4 x M 16	43	43	43	25	-
50	PN 40	4 x M 16	55	55	55	31	36
65	PN 16	4 x M 16	51	51	51	42	18
65	PN 40	8 x M 16	38	38	38	21	-
80	PN 40	8 x M 16	47	47	47	25	33
100	PN 16	8 x M 16	39	39	39	30	30
125	PN 16	8 x M 16	53	53	53	40	43
150	PN 16	8 x M 20	68	68	68	47	68
200	PN 10	8 x M 20	84	84	84	68	50
200	PN 16	12 x M 20	68	68	68	45	-
250	PN 10	12 x M 20	78	78	78	65	48
250	PN 16	12 x M 24	116	116	116	78	-
300	PN 10	12 x M 20	88	88	88	76	59
300	PN 16	12 x M 24	144	144	144	105	-
350	PN 10	16 x M 20	97	97	97	75	67
400	PN 10	16 x M 24	139	139	139	104	97
450	PN 10	20 x M 24	-	127	127	93	89
500	PN 10	20 x M 24	-	149	149	107	103
600	PN 10	20 x M 27	-	205	205	138	144
700	PN 10	20 x M 27	-	238	238	163	-
800	PN 10	24 x M 30	-	328	328	219	-
900	PN 10	28 x M 30	-	308	308	205	-
1000	PN 10	28 x M 35	-	392	392	261	-
③ *							

① The specified torque values are dependent on variables (temperature, bolt material, gasket material, lubricants, etc.) which are not within the control of the manufacturer. Therefore the values should be regarded as indicative only.

② F= ASTM gr B7 Studbolts - F=0.14 - Carbon steel flanges

③ * Information DN > 1000; please contact the factory.

Nominal size [inch]	Flange class [lb]	Bolts ②	Max. torque [in-lb] ①				
			PFA	PTFE	ETFE	PU	Soft rubber
1/10	150	4 x 1/2"		39	-	-	-
1/6	150	4 x 1/2"		39	-	-	-
1/4	150	4 x 1/2"		39	-	-	-
3/8	150	4 x 1/2"	39	39	-	-	-
1/2	150	4 x 1/2"	34	34	-	-	-
3/4	150	4 x 1/2"	50	50	-	-	-
1	150	4 x 1/2"	67	67	67	-	-
1 1/4	150	4 x 1/2"	97	97	97	-	-
1 1/2	150	4 x 1/2"	138	138	138	-	-
2	150	4 x 5/8"	225	225	225	-	158
3	150	4 x 5/8"	380	380	380	-	283
4	150	8 x 5/8"	300	300	300	-	207
6	150	8 x 3/4"	540	540	540	-	328
8	150	8 x 3/4"	979	979	979	818	418
10	150	12 x 7/8"	1104	1104	1104	923	601
12	150	12 x 7/8"	1478	1478	1478	1237	676
14	150	12 x 1"	1835	1835	1835	1538	909
16	150	16 x 1"	1767	1767	1767	1481	1141
18	150	16 x 1 1/8"	-	2605	2605	2183	1100
20	150	20 x 1 1/8"	-	2365	2365	1984	1618
24	150	20 x 1 1/4"	-	3419	3419	2873	1479
28	150	28 x 1 1/4"	-	2904	2904	-	2155
32	150	28 x 1 1/2"	-	4560	4560	-	-
36	150	32 x 1 1/2"	-	-	③ *	-	-
40	150	36 x 1 1/2"	-	-	*	-	-

① The specified torque values are dependent on variables (temperature, bolt material, gasket material, lubricants, etc.) which are not within the control of the manufacturer. Therefore the values should be regarded as indicative only.

② F= ASTM gr B7 Studbolts - F=0.14 - Carbon steel flanges

③ Information * ; please contact the factory



NOTICE!

Other sizes / pressure ratings on request.



CAUTION!

- Pressures are applicable at 20° C / 68° F.
- For higher temperatures, the pressure ratings are as per ASME B16.5.

2.9.2 Temperatures

CAUTION!

Protect the device from direct sunlight.

Temperature range	Process [°C]		Ambient [°C]		Process [°F]		Ambient [°F]	
	min.	max.	min.	max.	min.	max.	min.	max.

PTFE & PFA

Separate flow sensor	-40	180	-40	65	-40	356	-40	149
Compact with IMT33A	-40	140	-40	65	-40	284	-40	149
Compact with IMT31A	-40	120	-40	65	-40	248	-40	149
Compact with IMT30A	-40	120	-40 ①	65 ①	-40	248	-40 ①	149 ①

ETFE

Separate flow sensor	-40	120	-40	65	-40	248	-40	149
Compact with IMT33A	-40	120	-40	65	-40	248	-40	149
Compact with IMT31A	-40	120	-40	65	-40	248	-40	149
Compact with IMT30A	-40	120	-40	65	-40	248	-40	149

Hard rubber

Separate flow sensor ②	-5	80	-40	65	23	176	-40	149
Compact with IMT33A ②	-5	80	-40	65	23	176	-40	149
Compact with IMT31A ②	-5	80	-40	65	23	176	-40	149
Compact with IMT30A	-5	80	-40	65	23	176	-40	149

PU

Separate flow sensor	-5	65	-40	65	23	149	-40	149
Compact with IMT33A	-5	65	-40	65	23	149	-40	149
Compact with IMT31A	-5	65	-40	65	23	149	-40	149
Compact with IMT30A	-5	65	-40	65	23	149	-40	149

① Max. ambient temperature is 60°C / 140°F, but process temperature is then limited to 60°C / 140°F.

② Hard rubber liner is available for Ex-versions only.

NOTICE!

Ambient temperatures below -25°C / -13°F may affect the readability of the display

3.1 Safety instructions

**DANGER!**

All work on the electrical connections may only be carried out with the power disconnected.
Take note of the voltage data on the nameplate!

**DANGER!**

Observe the national regulations for electrical installations!

**DANGER!**

For devices used in hazardous areas, additional safety notes apply; please refer to the Ex documentation.

**WARNING!**

Observe without fail the local occupational health and safety regulations.
Any work done on the electrical components of the measuring device may only be carried out by properly trained specialists.

**NOTICE!**

Look at the device nameplate to ensure that the device is delivered according to your order.
Check for the correct supply voltage printed on the nameplate.

3.2 Grounding

**DANGER!**

The device must be grounded in accordance with regulations in order to protect personnel against electric shocks.

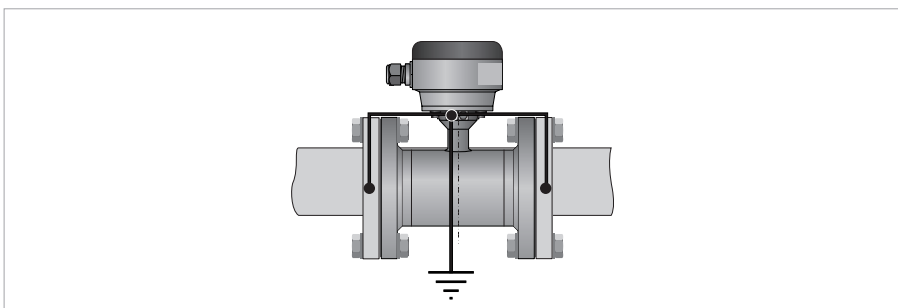

Figure 3-1: Grounding

Metal pipelines, not internally coated. Grounding without grounding rings.

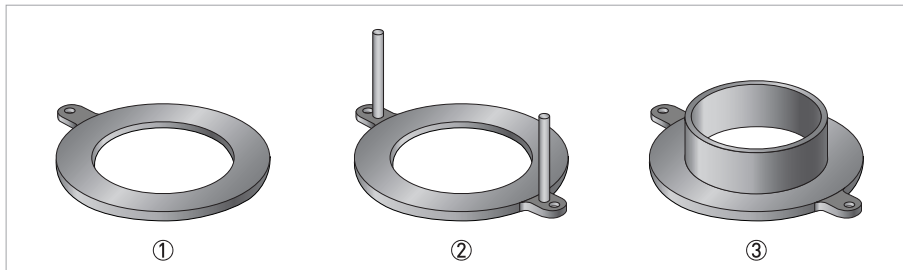

Figure 3-2: Different types of grounding rings

- ① Grounding ring number 1
- ② Grounding ring number 2
- ③ Grounding ring number 3

Grounding ring number 1:

- Thickness : 3 mm / 0.1" (tantalum: 0.5 mm / 0.02")

Grounding ring number 2:

- Thickness : 3 mm / 0.1"
- Prevents damage to the flanges during transport and installation
- Especially for flow sensors tube with PTFE liner

Grounding ring number 3:

- Thickness : 3 mm / 0.1"
- With cylindrical neck (length 30 mm / 1.25" for DN10...150 / 3/8...6")
- Offers liner protection against abrasive fluids

3.3 Virtual reference for IMT33A (4, N and H version)

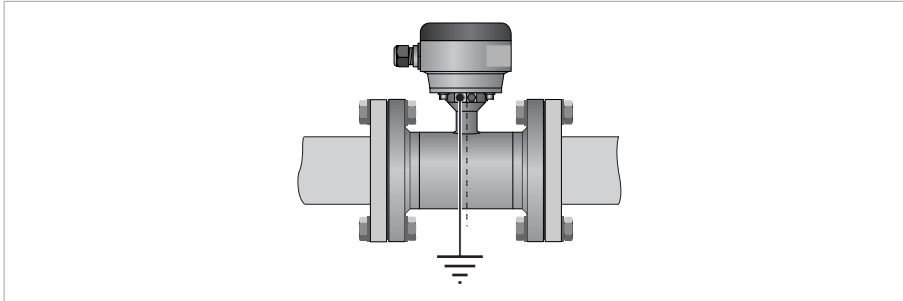

Figure 3-3: Virtual reference

Minimum requirements:

- Size: \geq DN10 / 3/8"
- Electrical conductivity: \geq 200 μ S/cm
- Signal cable: max. 50 m / 164 ft, type DS

3.4 Connection diagrams



NOTICE!

For the connection diagrams the documentation of the applicable transmitter.

4.1 Dimensions and weights

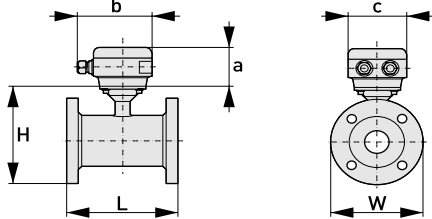
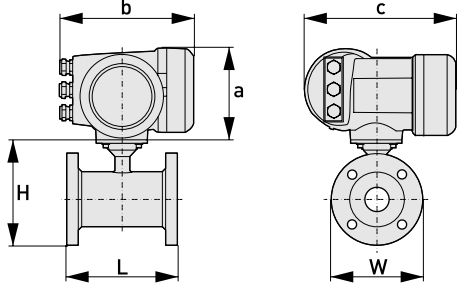
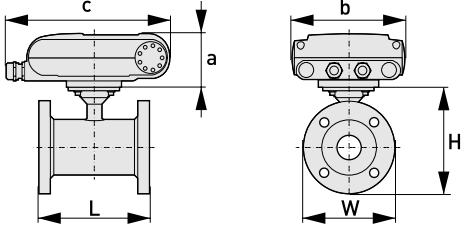
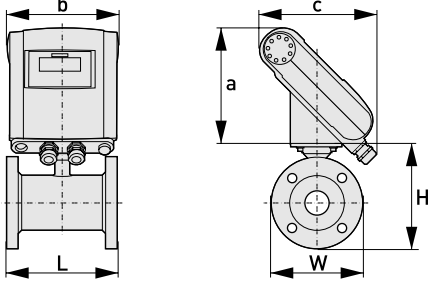
<p>Remote version</p>		<p>a = 88 mm / 3.5"</p> <p>b = 139 mm / 5.5" ①</p> <p>c = 106 mm / 4.2"</p> <p>Total height = H + a</p>
<p>Compact version with: IMT33A</p>		<p>a = 155 mm / 6.1"</p> <p>b = 230 mm / 9.1" ①</p> <p>c = 260 mm / 10.2"</p> <p>Total height = H + a</p>
<p>Compact version with: IMT31A (0°)</p>		<p>a = 82 mm / 3.2"</p> <p>b = 161 mm / 6.3"</p> <p>c = 257 mm / 10.1" ①</p> <p>Total height = H + a</p>
<p>Compact version with: IMT31A (45°)</p>		<p>a = 186 mm / 7.3"</p> <p>b = 161 mm / 6.3"</p> <p>c = 184 mm / 7.3" ①</p> <p>Total height = H + a</p>

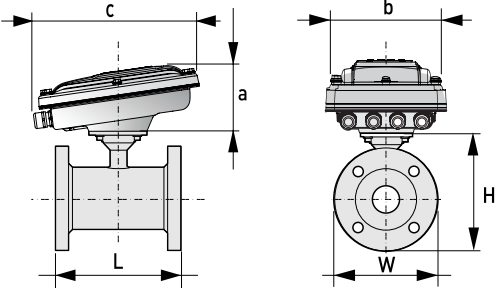
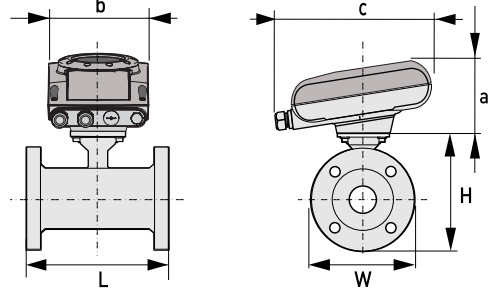
<p>Compact version with stainless steel IMT31A (10°)</p>		<p>a = 100 mm / 4" b = 187 mm / 7.36" ① c = 270 mm / 10.63" Total height = H + a</p>
<p>Compact version with: IMT30A (10°)</p>		<p>a = 100mm / 4" b = 157 mm / 6.18" ① c = 260 mm / 10.24" Total height = H + a</p>

① The value may vary depending on the used cable glands.



NOTICE!

- All data given in the following tables are based on standard versions of the flow tube only.
- Especially for smaller nominal sizes of the flow tube, the signal transmitter can be bigger than the tube.
- Note that for other pressure ratings than mentioned, the dimensions may be different.
- For full information on signal transmitter dimensions see relevant documentation.

EN 1092-1

Nominal size		Dimensions [mm]				Approximately weight [kg]
DN	PN [bar]	L		H	W	
		DIN	ISO 13359			
10	40	150	-	106	90	6
15	40	150	200	106	95	6
20	40	150	200	158	105	7
25	40	150	200	140	115	4
32	40	150	200	157	140	5
40	40	150	200	166	150	5
50	40	200	200	186	165	9
65	16	200	200	200	185	9
80	40	200	200	209	200	12
100	16	250	250	237	220	15
125	16	250	250	266	250	19
150	16	300	300	300	285	27
200	10	350	350	361	340	34
250	10	400	450	408	395	48
300	10	500	500	458	445	58
350	10	500	550	510	505	78
400	10	600	600	568	565	101
450	10	600	-	618	615	111
500	10	600	-	671	670	130
600	10	600	-	781	780	165
700	10	700	-	898	895	248
800	10	800	-	1012	1015	331
900	10	900	-	1114	1115	430
1000	10	1000	-	1225	1230	507
1200	6	1200	-	1417	1405	555
1400	6	1400	-	1619	1630	765
1600	6	1600	-	1819	1830	1035
1800	6	1800	-	2027	2045	1470
2000	6	2000	-	2259	2265	1860

150 lb flanges

Nominal size		Dimensions [inch]				Approximately weight [lb]
ASME	PN [psi]	L		H	W	
		DIN	ISO 13359			
3/8"	284	5.91	-	5.08	3.50	12
1/2"	284	5.91	7.87	5.08	3.50	12
3/4"	284	5.91	7.87	5.28	3.88	18
1"	284	5.91	7.87	5.39	4.25	7
1 1/4"	284	5.91	7.87	5.98	4.62	7
1 1/2"	284	5.91	7.87	6.10	5.00	11
2"	284	7.87	7.87	7.05	5.98	18
2 1/2"	284	7.87	7.87	7.72	7.00	24
3"	284	7.87	7.87	8.03	7.50	26
4"	284	9.84	9.84	9.49	9.00	40
5"	284	9.84	9.84	10.55	10.0	49
6"	284	11.81	11.81	11.69	11.0	64
8"	284	13.78	13.78	14.25	13.5	95
10"	284	15.75	17.71	16.3	16.0	143
12"	284	19.69	19.69	18.78	19.0	207
14"	284	27.56	21.65	20.67	21.0	284
16"	284	31.50	23.62	22.95	23.5	364
18"	284	31.50	-	24.72	25.0	410
20"	284	31.50	-	26.97	27.5	492
24"	284	31.50	-	31.38	32.0	675

**CAUTION!**

- Pressures at 20° C / 68° F.
- For higher temperatures, the pressure and temperature ratings are as per ASME B16.5.

300 lb flanges

Nominal size		Dimensions [inch]				Approximately weight [lb]
ASME	PN [psi]	L		H	W	
		DIN	ISO 13359			
3/8"	741	5.91	-	5.24	3.75	15
1/2"	741	5.91	7.87	5.24	3.75	15
3/4"	741	5.91	7.87	5.67	4.62	20
1"	741	5.91	7.87	5.71	4.87	11
1 1/2"	741	7.87	7.87	6.65	6.13	13
2"	741	9.84	7.87	7.32	6.50	22
3"	741	9.84	7.87	8.43	8.25	31
4"	741	11.81	9.84	10.00	10.0	44
6"	741	12.60	11.81	12.44	12.5	73
8"	741	15.75	13.78	15.04	15.0	157
10"	741	19.69	17.71	17.05	17.5	247
12"	741	23.62	-	20.00	20.5	375
14"	741	27.56	-	21.65	23.0	474
16"	741	31.50	-	23.98	25.5	639
20"	741	31.50	-	28.46	30.5	937
24"	741	31.50	-	33.39	36.0	1345

**CAUTION!**

- Pressures at 20° C / 68° F.
- For higher temperatures, the pressure and temperature ratings are as per ASME B16.5.

4.2 Vacuum load

Diameter	Max. pressure	Vacuum load in mbar abs. at a process temperature of									
		[mm]	[bar]	40°C	60°C	70°C	80°C	90°C	100°C	120°C	140°C
Liner in PTFE											
DN10...20	50	0	0	0	0	0	0	0	500	750	1000
DN200...300	50	500	750	1000	1000	1000	1000	1000	1000	1000	1000
DN350...600	50	800	1000	1000	1000	1000	1000	1000	1000	1000	1000
Liner in PFA											
DN25...150	50	0	0	0	0	0	0	0	0	0	0
Liner in ETFE											
DN200...2000	150	100	100	100	100	100	100	100	100	-	-
Liner in Hard rubber											
DN200...300	150	250	400	400	400	-	-	-	-	-	-
DN350...2000	150	500	600	600	600	-	-	-	-	-	-
Liner in PU											
DN200...1800	1500	500	600	-	-	-	-	-	-	-	-
Liner in Soft rubber											
DN50...600	40	1000	1000	-	-	-	-	-	-	-	-

Diameter	Max. pressure	Vacuum load in psia at a process temperature of									
		[inch]	[psi]	104°F	140°F	158°F	176°F	194°F	212°F	248°F	284°F
Liner in PTFE											
3/8...3/4"	725	0	0	0	0	0	0	0	7.3	10.9	14.5
8...12"	725	7.3	10.9	14.5	14.5	14.5	14.5	14.5	14.5	14.5	14.5
14...24"	725	11.6	14.5	14.5	14.5	14.5	14.5	14.5	14.5	14.5	14.5
Liner in PFA											
1...6"	725	0	0	0	0	0	0	0	0	0	0
Liner in ETFE											
8...72"	2176	1.5	1.5	1.5	1.5	1.5	1.5	1.5	1.5	-	-
Liner in Hard rubber											
8...12"	2176	3.6	5.8	5.8	5.8	-	-	-	-	-	-
14...80"	2176	7.3	8.7	8.7	8.7	-	-	-	-	-	-
Liner in PU											
8...72"	21756	7.3	8.7	-	-	-	-	-	-	-	-
Liner in Soft rubber											
2...24"	580	14.5	14.5	-	-	-	-	-	-	-	-



Schneider Electric Systems USA, Inc. Global Customer Support
38 Neponset Avenue Inside U.S.: 1-866-746-6477
Foxboro, MA 02035 Outside U.S.: 1-508-549-2424
United States of America <https://pasupport.schneider-electric.com>
<http://www.se.com>

Copyright 2020 Schneider Electric Systems USA, Inc.
All rights reserved.

The Schneider Electric brand and any trademarks of
Schneider Electric SE or its subsidiaries are the property
of Schneider Electric SE or its subsidiaries.
All other trademarks are the property of their respective
owners.

