

Instruction

MI 021-520 en

FEBRUARY 2020

Model 9500A Magnetic Flow Tube

Quick Start

1	Safety instructions	3
<hr/>		
2	Installation	4
<hr/>		
2.1	Scope of delivery.....	4
2.2	Device description	5
2.3	Nameplate	6
2.4	Storage	6
2.5	Transport	7
2.6	Pre-installation requirements	7
2.7	General requirements	8
2.7.1	Vibrations	8
2.7.2	Magnetic field.....	8
2.8	Installation conditions	9
2.8.1	Inlet and outlet	9
2.8.2	Bends in 2 or 3 dimensions.....	9
2.8.3	T-section	10
2.8.4	Bends	10
2.8.5	Open discharge	11
2.8.6	Pump	11
2.8.7	Control valve	11
2.8.8	Air venting and vacuum forces	12
2.8.9	Flange deviation.....	13
2.8.10	Mounting position.....	13
2.9	Mounting.....	14
2.9.1	Torques and pressures.....	14
3	Electrical connections	18
<hr/>		
3.1	Safety instructions.....	18
3.2	Grounding	18
3.3	Virtual reference for IMT33A (4, N and H version).....	20
3.4	Connection diagrams	20
4	Technical data	21
<hr/>		
4.1	Dimensions and weights	21
4.2	Vacuum load	25
5	Notes	26
<hr/>		

Warnings and symbols used



DANGER!

This information refers to the immediate danger when working with electricity.



DANGER!

These warnings must be observed without fail. Even partial disregard of this warning can lead to serious health problems and even death.



WARNING!

Disregarding this safety warning, even if only in part, poses the risk of serious health problems. There is also the risk of damaging the device or parts of the operator's plant.



CAUTION!

Disregarding these instructions can result in damage to the device or to parts of the operator's plant.



NOTICE!

These instructions contain important information for the handling of the device.



HANDLING

- This symbol designates all instructions for actions to be carried out by the operator in the specified sequence.

➔ **RESULT**

This symbol refers to all important consequences of the previous actions.

Safety instructions for the operator



CAUTION!

Installation, assembly, start-up and maintenance may only be performed by appropriately trained personnel. The regional occupational health and safety directives must always be observed.



LEGAL NOTICE!

The responsibility as to the suitability and intended use of this device rests solely with the user. The supplier assumes no responsibility in the event of improper use by the customer. Improper installation and operation may lead to loss of warranty. In addition, the "Terms and Conditions of Sale" apply which form the basis of the purchase contract.



NOTICE!

Further information can be found on the website.

2.1 Scope of delivery

**NOTICE!**

Do a check of the packing list to make sure that you have all the elements given in the order.

**NOTICE!**

Inspect the packaging carefully for damages or signs of rough handling. Report damage to the carrier and to the local office of the manufacturer.

**NOTICE!**

The remote version will arrive in two cartons. One carton contains the signal transmitter and one carton contains the flow tube.

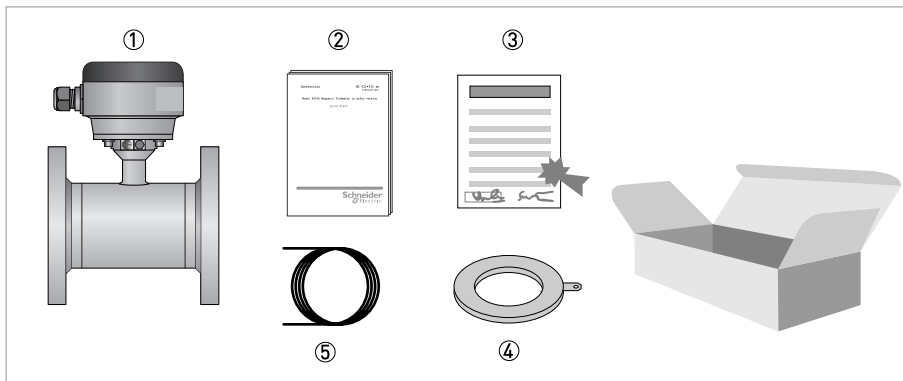

Figure 2-1: Scope of delivery

- ① Ordered flowmeter
- ② Product documentation
- ③ Factory calibration report
- ④ Grounding rings (optional)
- ⑤ Signal cable (remote versions only)

**NOTICE!**

Assembly materials and tools are not part of the delivery. Use the assembly materials and tools in compliance with the applicable occupational health and safety directives.

2.2 Device description

Your measuring device is supplied ready for operation. The factory settings for the operating data have been made in accordance with your order specifications.

The following versions are available:

- Compact version (the transmitter is mounted directly on the flow tube)
- Remote version (a measuring tube with connection box and a separate transmitter)

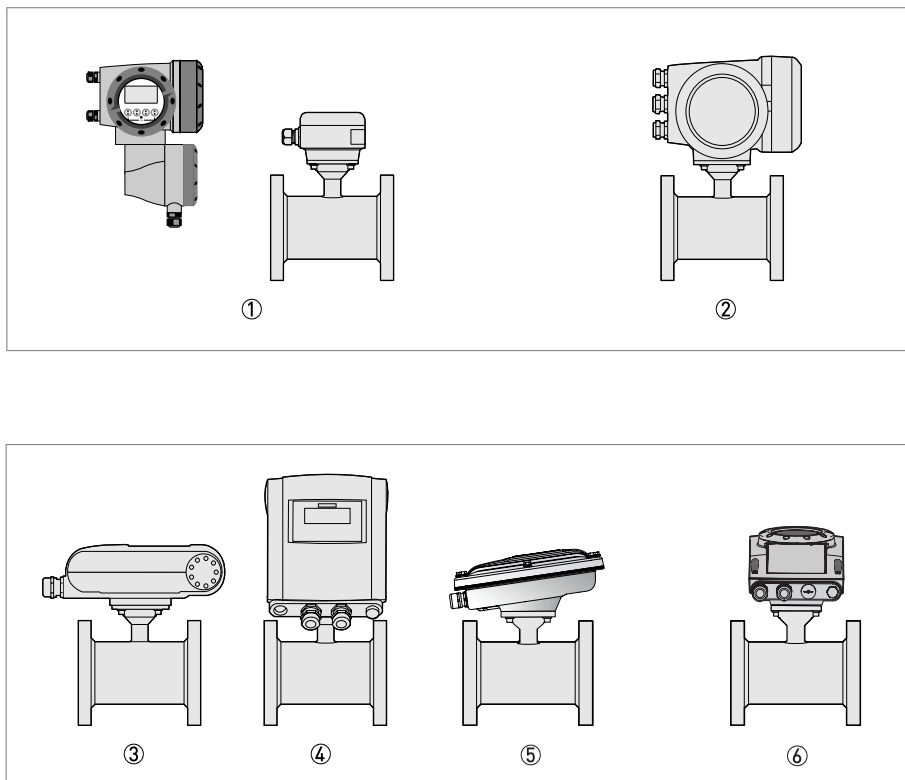

Figure 2-2: Device versions

- ① Remote version
- ② Compact version with signal transmitter IMT33A
- ③ Compact version with signal transmitter IMT31A (0°)
- ④ Compact version with signal transmitter IMT31A (45°)
- ⑤ Compact version with stainless steel signal transmitter IMT31A (10°)
- ⑥ Compact version with signal transmitter IMT30A (10°)

2.3 Nameplate



NOTICE!

Check the device nameplate to ensure that the device is delivered according to your order. Additional information (e.g. correct supply voltage), can be found in the documentation of the transmitter.

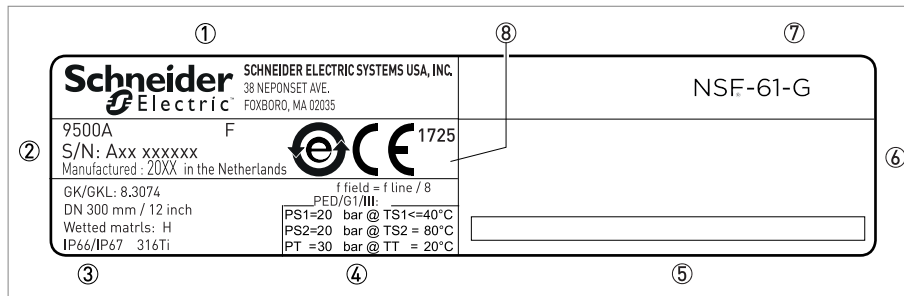

Figure 2-3: Example of nameplate

- ① Name and address of the manufacturer
- ② Type designation of the flowmeter, serial number and manufacturing date
- ③ Calibration data
- ④ PED data
- ⑤ Tag number
- ⑥ Additional information
- ⑦ NSF product certification marking
- ⑧ Disposal logo and CE sign with number(s) of notified body / bodies

2.4 Storage

- Store the device in a dry and dust-free location.
- Avoid lasting direct exposure to the sun.
- Store the device in its original packaging.
- Storage temperature: -50...+70°C / -58...+158°F

2.5 Transport

Signal converter

- No special requirements.

Compact version

- Do not lift the device by the signal converter housing.
- Do not use lifting chains.
- To transport flange devices, use lifting straps. Wrap these around both process connections.

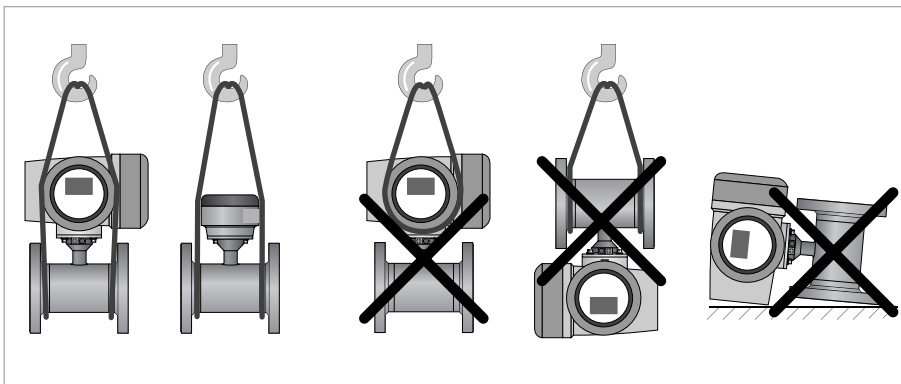

Figure 2-4: Transport

2.6 Pre-installation requirements

Make sure that you have all necessary tools available:

- Allen key (4 mm)
- Small screwdriver
- Wrench for cable glands
- Wrench for wall mounting bracket (remote version only)
- Torque wrench for installing flowmeter in pipeline

2.7 General requirements

**NOTICE!**

The following precautions must be taken to ensure reliable installation.

- *Make sure that there is adequate space to the sides.*
- *Protect the transmitter from direct sunlight and install a sun shade if necessary.*
- *Transmitters installed in control cabinets require adequate cooling, e.g. by fan or heat exchanger.*
- *Do not expose the transmitter to intense vibration. The flowmeters are tested for a vibration level in accordance with IEC 60068-2-64.*
- *Avoid magnetic field! Keep at least 5 DN distance between electromagnetic flow tubes.*

2.7.1 Vibrations

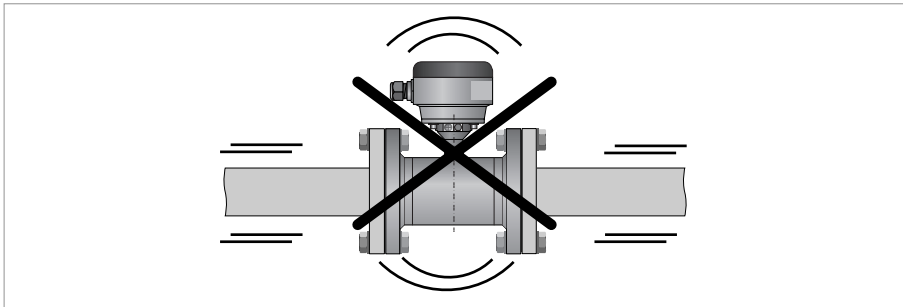

Figure 2-5: Avoid vibrations

2.7.2 Magnetic field

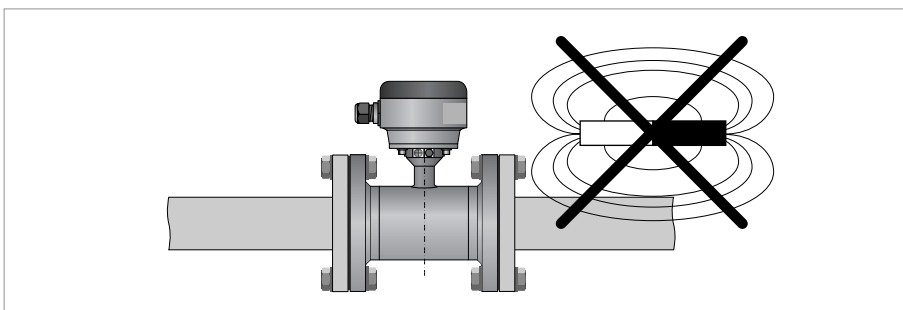

Figure 2-6: Avoid magnetic field

2.8 Installation conditions

2.8.1 Inlet and outlet

Use straight inlet and outlet pipe sections to prevent flow distortion or swirl, caused by bends and T- sections.

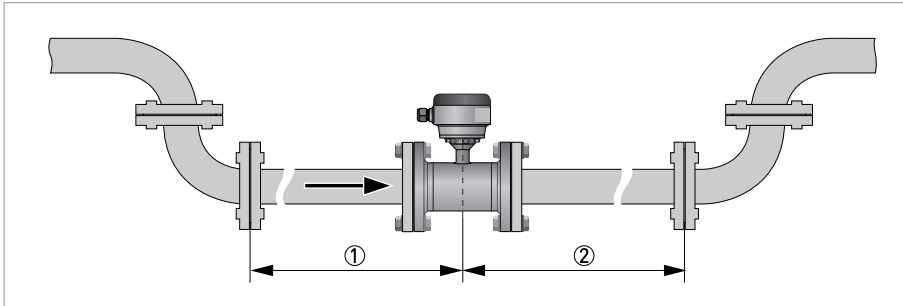

Figure 2-7: Recommended inlet and outlet section

- ① Refer to chapter "Bends in 2 or 3 dimensions"
- ② ≥ 2 DN

2.8.2 Bends in 2 or 3 dimensions

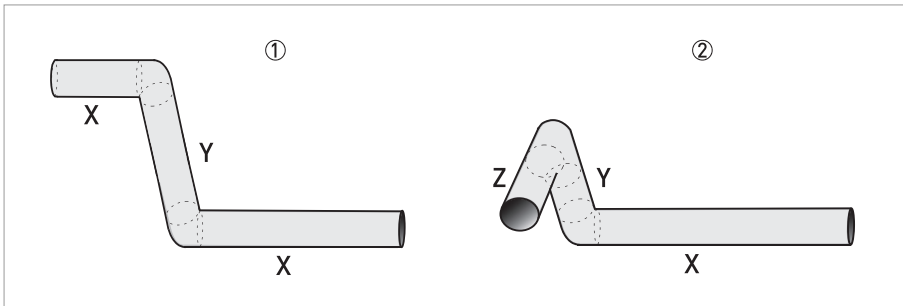

Figure 2-8: 2 and/or 3 dimensional bends upstream of the flowmeter

- ① 2 dimensions = X/Y
 - ② 3 dimensions = X/Y/Z
- Inlet length: using bends in 2 dimensions: ≥ 5 DN; when having bends in 3 dimensions: ≥ 10 DN



NOTICE!

2 dimensional bends occur in a vertical **or** horizontal plane (X/Y) only, while 3 dimensional bends occur in both vertical **and** horizontal plane (X/Y/Z).

2.8.3 T-section

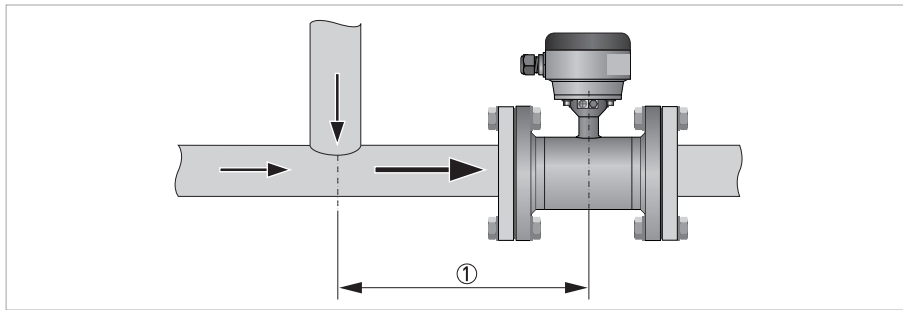

Figure 2-9: Distance behind a T-section

① ≥ 10 DN

2.8.4 Bends

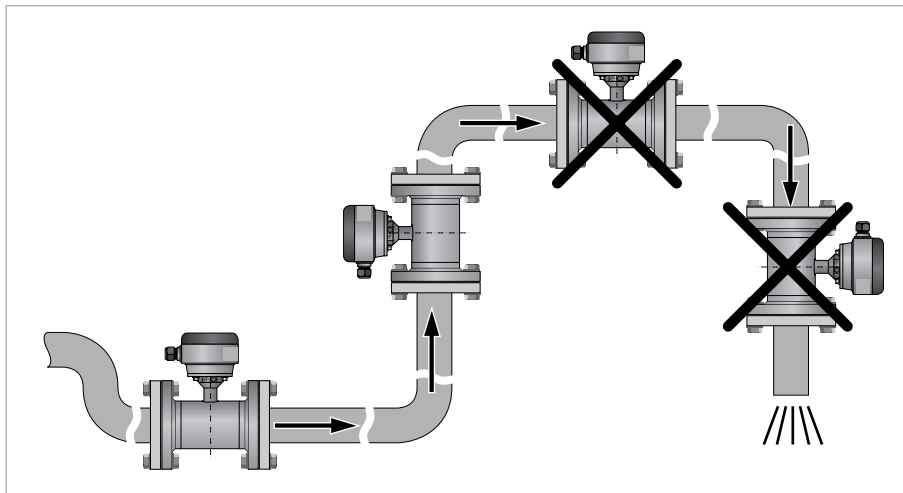

Figure 2-10: Installation in bending pipes (90°)

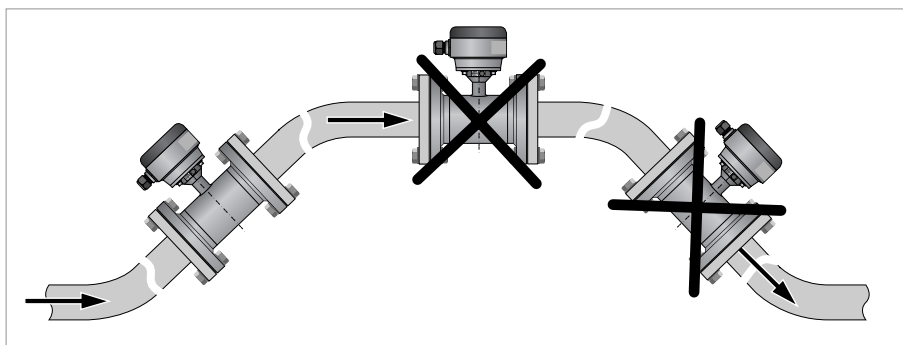

Figure 2-11: Installation in bending pipes (45°)



CAUTION!

Avoid draining or partial filling of the flow tube

2.8.5 Open discharge

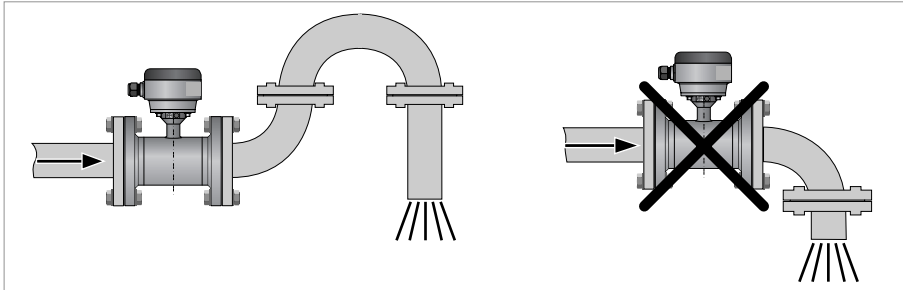

Figure 2-12: Installation in front of an open discharge

2.8.6 Pump

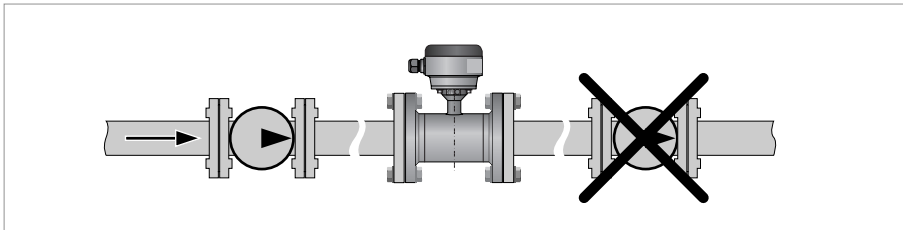

Figure 2-13: Installation behind a pump

2.8.7 Control valve

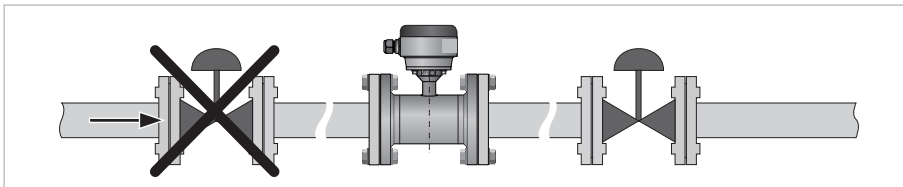

Figure 2-14: Installation in front of a control valve

2.8.8 Air venting and vacuum forces

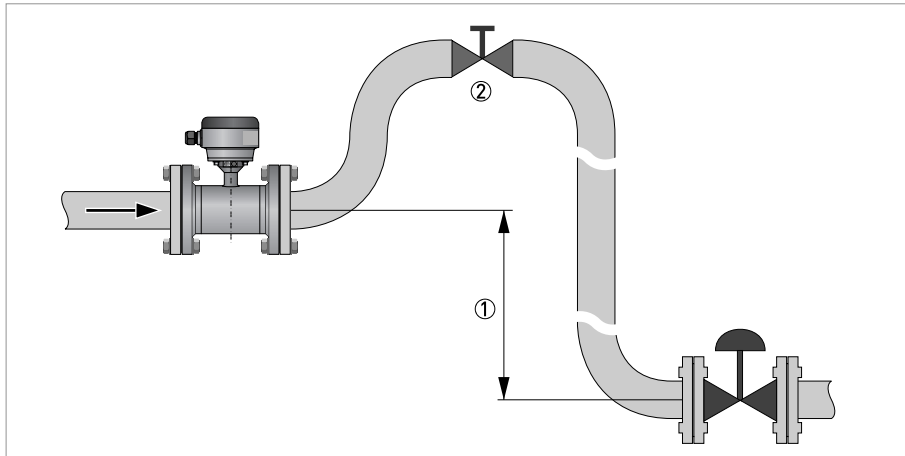

Figure 2-15: Air venting

- ① $\geq 5\text{ m} / 17\text{ ft}$
- ② Air ventilation point

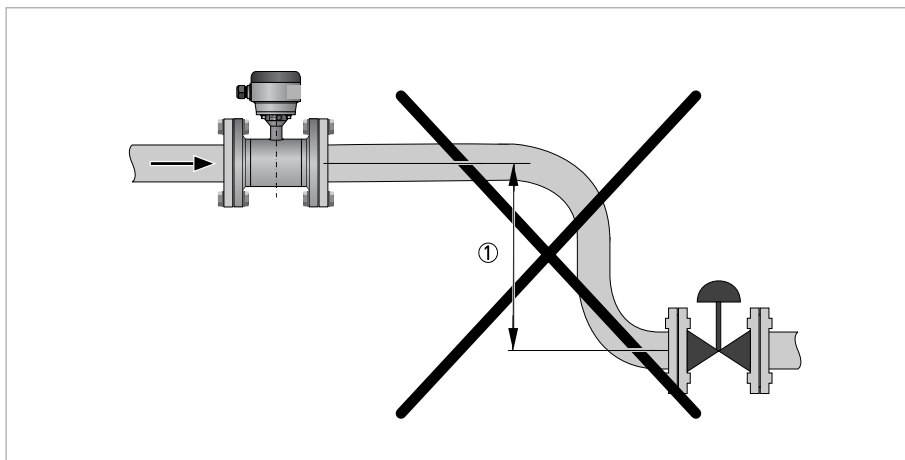

Figure 2-16: Vacuum

- ① $\geq 5\text{ m} / 17\text{ ft}$

2.8.9 Flange deviation



CAUTION!

Max. permissible deviation of pipe flange faces:
 $L_{max} - L_{min} \leq 0.5 \text{ mm} / 0.02''$

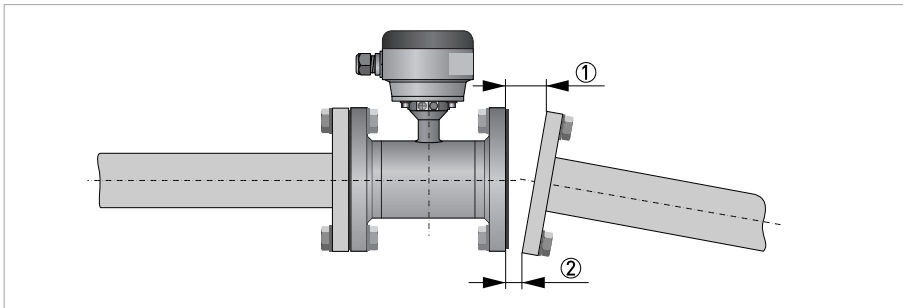

Figure 2-17: Flange deviation

- ① L_{max}
- ② L_{min}

2.8.10 Mounting position

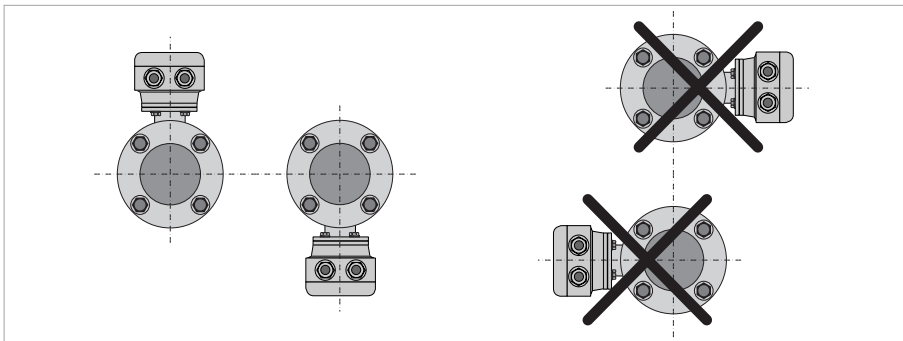

Figure 2-18: Mounting position

- Install flow tube in line with the pipe axis.
- Pipe flange faces must be parallel to each other.

2.9 Mounting

**CAUTION!**

Please take care to use the proper gasket to prevent damaging the liner of the flowmeter. In general, the use of spiral wound gaskets is not advised, as it could severely damage the liner of the flowmeter.

2.9.1 Torques and pressures

The maximum pressure and torques values for the flowmeter are theoretical and calculated for optimum conditions and use with carbon steel flanges.

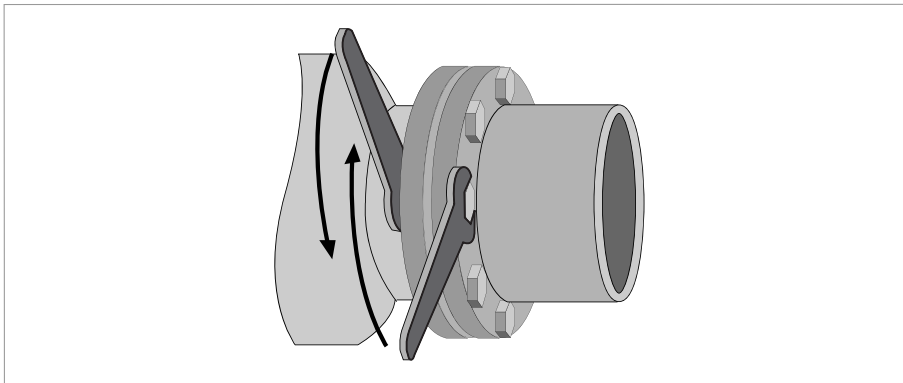

Figure 2-19: Tightening of bolts



- Always tighten the bolts uniformly and in diagonally opposite sequence.
- Do not exceed the maximum torque value.
- Step 1: Apply approx. 50% of max. torque given in table.
- Step 2: Apply approx. 80% of max. torque given in table.
- Step 3: Apply 100% of max. torque given in table.

Nominal size DN [mm]	Pressure rating	Bolts	Max. torque [Nm] ^①	
			Polyolefin	Hard rubber
25	PN 40	4 x M 12	-	11
32	PN 40	4 x M 16	-	19
40	PN 40	4 x M 16	-	25
50	PN 40	4 x M 16	-	31
65	PN 16	② x M 16	-	42
65	PN 40	8 x M 16	-	21
80	PN 40	8 x M 16	-	25
100	PN 16	8 x M 16	-	30
125	PN 16	8 x M 16	-	40
150	PN 16	8 x M 20	-	47
200	PN 10	8 x M 20	68	68
200	PN 16	12 x M 20	45	45
250	PN 10	12 x M 20	65	65
250	PN 16	12 x M 24	78	78
300	PN 10	12 x M 20	76	76
300	PN 16	12 x M 24	105	105
350	PN 10	16 x M 20	75	75
400	PN 10	16 x M 24	104	104
450	PN 10	20 x M 24	93	93
500	PN 10	20 x M 24	107	107
600	PN 10	20 x M 27	138	138
700	PN 10	24 x M 27	163	163
800	PN 10	24 x M 30	219	219
900	PN 10	28 x M 30	205	205
1000	PN 10	28 x M 33	261	261

① The specified torque values are dependent on variables (temperature, bolt material, gasket material, lubricants, etc.) which are not within the control of the manufacturer. Therefore the values should be regarded as indicative only.

② DN65 / PN16 is available with standard 8 bolt holes.

Nominal size [inch]	Flange class [lb]	Bolts	Max. torque [lb.ft] ①	
			Polyolefin	Hard rubber
1	150	4 x 1/2"	-	3.2
1 1/2	150	4 x 1/2"	-	9
2	150	4 x 5/8"	-	17
3	150	4 x 5/8"	-	29
4	150	8 x 5/8"	-	23
6	150	8 x 3/4"	-	38
8	150	8 x 3/4"	51	51
10	150	12 x 7/8"	58	58
12	150	12 x 7/8"	77	77
14	150	12 x 1"	69	69
16	150	16 x 1"	67	67
18	150	16 x 1 1/8"	105	105
20	150	20 x 1 1/8"	94	94
24	150	20 x 1 1/4"	133	133
28	150	28 x 1 1/4"	119	119
32	150	28 x 1 1/2"	191	191
36	150	32 x 1 1/2"	198	198
40	150	36 x 1 1/2"	198	198

① The specified torque values are dependent on variables (temperature, bolt material, gasket material, lubricants, etc.) which are not within the control of the manufacturer. Therefore the values should be regarded as indicative only.

Nominal size [inch]	Flange class [lb]	Bolts	Max. torque [lb.ft] ①	
			Polyolefin	Hard rubber
1	300	4 x 5/8"	-	5
1 1/2	300	4 x 3/4"	-	20
2	300	8 x 5/8"	-	13
3	300	8 x 3/4"	-	30
4	300	8 x 3/4"	-	47
6	300	12 x 3/4"	-	38
8	300	12 x 7/8"	60	60
10	300	16 x 1"	75	75
12	300	16 x 1 1/8"	113	113
14	300	20 x 1 1/4"	71	71
16	300	20 x 1 1/4"	92	92
18	300	24 x 1 1/4"	108	108
20	300	24 x 1 1/4"	121	121
24	300	24 x 1 1/2"	189	189

① The specified torque values are dependent on variables (temperature, bolt material, gasket material, lubricants, etc.) which are not within the control of the manufacturer. Therefore the values should be regarded as indicative only.



CAUTION!

- Pressures are applicable at 20°C / 68°F.
- For higher temperatures, the pressure ratings are as per ASME B16.5.

3.1 Safety instructions



DANGER!

All work on the electrical connections may only be carried out with the power disconnected. Take note of the voltage data on the nameplate!



DANGER!

Observe the national regulations for electrical installations!



DANGER!

For devices used in hazardous areas, additional safety notes apply; please refer to the Ex documentation.



WARNING!

Observe without fail the local occupational health and safety regulations. Any work done on the electrical components of the measuring device may only be carried out by properly trained specialists.



NOTICE!

Look at the device nameplate to ensure that the device is delivered according to your order. Check for the correct supply voltage printed on the nameplate.

3.2 Grounding



DANGER!

The device must be grounded in accordance with regulations in order to protect personnel against electric shocks.

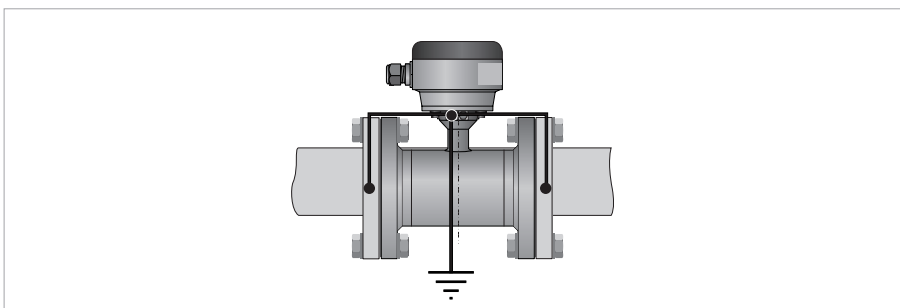

Figure 3-1: Grounding

Metal pipelines, not internally coated. Grounding without grounding rings.

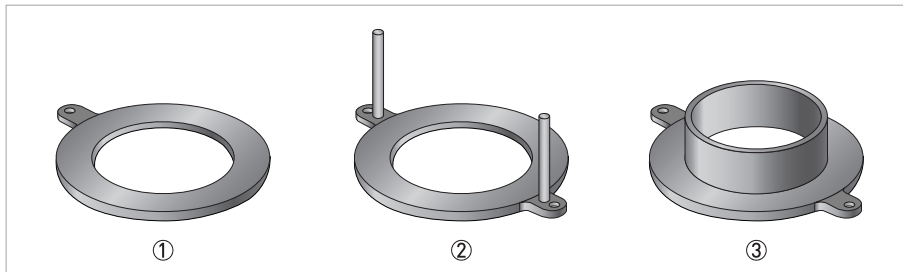

Figure 3-2: Different types of grounding rings

- ① Grounding ring number 1
- ② Grounding ring number 2
- ③ Grounding ring number 3

Grounding ring number 1:

- Thickness : 3 mm / 0.1" (tantalum: 0.5 mm / 0.02")

Grounding ring number 2:

- Thickness : 3 mm / 0.1"
- Prevents damage to the flanges during transport and installation
- Especially for flow sensors tube with PTFE liner

Grounding ring number 3:

- Thickness : 3 mm / 0.1"
- With cylindrical neck (length 30 mm / 1.25" for DN10...150 / 3/8...6")
- Offers liner protection against abrasive fluids

3.3 Virtual reference for IMT33A (4, N and H version)

The virtual reference option on the transmitter IMT33A provides complete isolation of the measurement circuit.

Benefits of virtual reference:

- Grounding rings or grounding electrodes can be omitted.
- Safety increases by reducing the number of potential leakage points.
- The installation of the flowmeters is much easier.

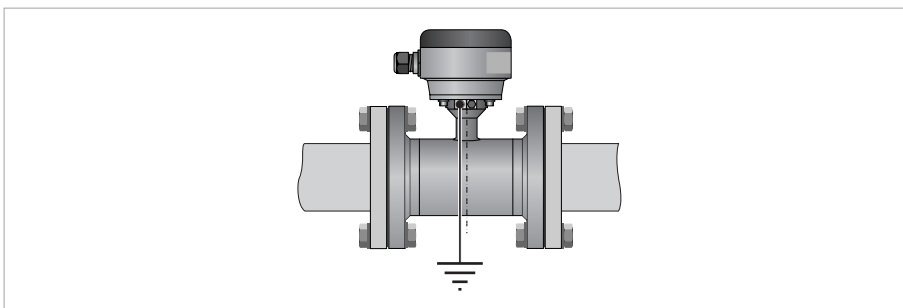

Figure 3-3: Virtual reference

Minimum requirements:

- Size: \geq DN10 / 3/8"
- Electrical conductivity: \geq 200 μ S/cm
- Signal cable: max. 50 m / 164 ft, type DS

3.4 Connection diagrams



NOTICE!

For the connection diagrams the documentation of the applicable transmitter.

4.1 Dimensions and weights

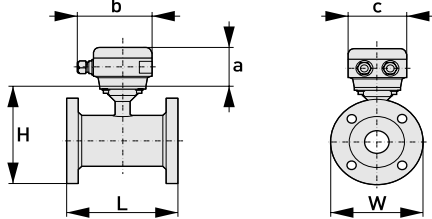
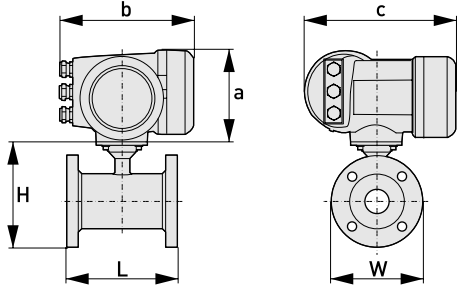
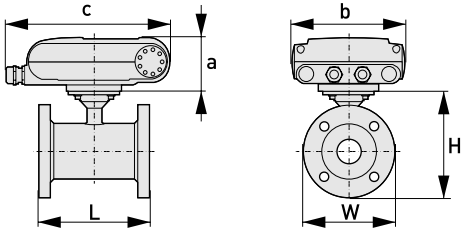
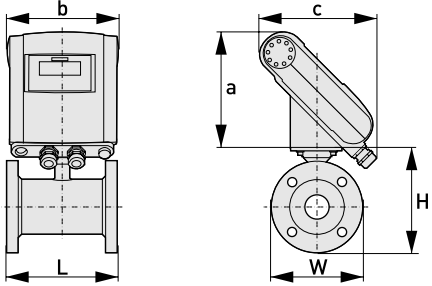
Remote version		<p>a = 88 mm / 3.5"</p> <p>b = 139 mm / 5.5" ①</p> <p>c = 106 mm / 4.2"</p> <p>Total height = H + a</p>
Compact version with: IMT33A		<p>a = 155 mm / 6.1"</p> <p>b = 230 mm / 9.1" ①</p> <p>c = 260 mm / 10.2"</p> <p>Total height = H + a</p>
Compact version with: IMT31A (0°)		<p>a = 82 mm / 3.2"</p> <p>b = 161 mm / 6.3"</p> <p>c = 257 mm / 10.1" ①</p> <p>Total height = H + a</p>
Compact version with: IMT31A (45°)		<p>a = 186 mm / 7.3"</p> <p>b = 161 mm / 6.3"</p> <p>c = 184 mm / 7.3" ①</p> <p>Total height = H + a</p>

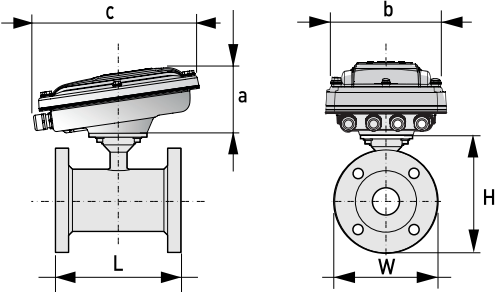
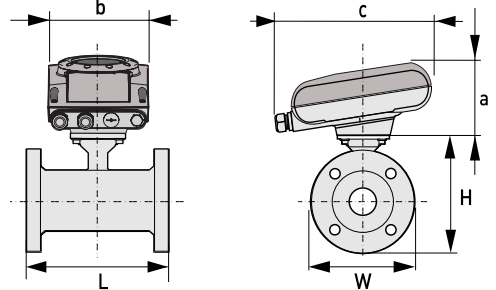
<p>Compact version with: stainless steel IMT31A (10°)</p>		<p>a = 100 mm / 4" b = 187 mm / 7.36" ① c = 270 mm / 10.63" Total height = H + a</p>
<p>Compact version with: IMT30A (10°)</p>		<p>a = 101 mm / 3.98" b = 157 mm / 6.18" c = 260 mm / 10.24" ① Total height = H + a</p>

① The value may vary depending on the used cable glands.

**NOTICE!**

- All data given in the following tables are based on standard versions of the flow tube only.
- Especially for smaller nominal sizes of the flow tube, the signal transmitter can be bigger than the tube.
- Note that for other pressure ratings than mentioned, the dimensions may be different.
- For full information on signal transmitter dimensions see relevant documentation.

EN 1092-1

Nominal size DN [mm]	Dimensions [mm]				Approx. weight [kg]
	Standard length	ISO Insertion length	H	W	
25	150	200	140	115	5
32	150	200	157	140	6
40	150	200	166	150	7
50	200	200	186	165	11
65	200	200	200	185	9
80	200	200	209	200	14
100	250	250	237	220	15
125	250	250	266	250	19
150	300	300	300	285	27
200	350	350	361	340	34
250	400	450	408	395	48
300	500	500	458	445	58
350	500	550	510	505	78
400	600	600	568	565	101
450	600	-	618	615	111
500	600	-	671	670	130
600	600	-	781	780	165
700	700	-	898	895	248
800	800	-	1012	1015	331
900	900	-	1114	1115	430
1000	1000	-	1225	1230	507
1200	1200	-	1417	1405	555
1400	1400	-	1619	1630	765
1600	1600	-	1819	1830	1035
1800	1800	-	2027	2045	1470
2000	2000	-	2259	2265	1860

ASME B16.5 / 150 lb flanges

Nominal size [inch]	Dimensions [inch]			Approx. weight [lb]
	L	H	W	
1"	5.91	5.39	4.25	9
1¼"	5.91	5.75	4.63	13
1½"	5.91	6.10	5.00	15
2"	7.87	7.05	5.98	18
2½"	7.87	7.72	7	22
3"	7.87	8.03	7.50	26
4"	9.84	9.49	9.00	44
5"	9.84	10.55	10.00	49
6"	11.81	11.69	11.00	64
8"	13.78	14.25	13.50	95
10"	15.75	16.30	16.00	143
12"	19.69	18.78	19.00	207
14"	27.56	20.67	21.00	284
16"	31.50	22.95	23.50	364
18"	31.50	24.72	25.00	410
20"	31.50	26.97	27.50	492
24"	31.50	31.38	32.00	675

ASME B16.5 / 300 lb flanges

Nominal size [inch]	Dimensions [inch]			Approx. weight [lb]
	L	H	W	
1"	5.91	5.71	4.87	11
1¼"	7.87	6.30	5.25	17
1½"	7.87	6.65	6.13	20
2"	9.84	7.32	6.50	22
2½"	9.84	7.95	7.5	25
3"	9.84	8.43	8.25	31
4"	11.81	10.00	10.00	44
6"	12.60	12.44	12.50	73
8"	15.75	15.04	15.00	157
10"	19.69	17.05	17.50	247
12"	23.62	20.00	20.50	375
14"	27.56	21.65	23.00	474
16"	31.50	23.98	25.50	639
20"	31.50	28.46	30.50	937
24"	31.50	33.39	36.00	1345

4.2 Vacuum load

Diameter	Vacuum load in mbar abs. at a process temperature of			
[mm]	20°C	40°C	60°C	80°C
Hard rubber				
DN25...300	250	250	400	400
DN350...1000	500	500	600	600
DN1200...2000	600	600	750	750
Polyolefin				
DN200...1000	0	0	0	0

Diameter	Vacuum load in psia at process temperature of			
[inch]	68°F	104°F	140°F	176°F
Hard rubber				
1...12	3.6	3.6	5.8	5.8
14...40	7.3	7.3	8.7	8.7
48...80	8.7	8.7	10.9	10.9
Polyolefin				
8...40	0	0	0	0





Schneider Electric Systems USA, Inc. Global Customer Support
38 Neponset Avenue Inside U.S.: 1-866-746-6477
Foxboro, MA 02035 Outside U.S.: 1-508-549-2424
United States of America <https://pasupport.schneider-electric.com>
<http://www.se.com>

Copyright 2020 Schneider Electric Systems USA, Inc.
All rights reserved.

The Schneider Electric brand and any trademarks of
Schneider Electric SE or its subsidiaries are the property
of Schneider Electric SE or its subsidiaries.
All other trademarks are the property of their respective
owners.

