

**Instruction**

**MI 021-535 en**

FEBRUARY 2020

**Model 8400A Magnetic Flowmeter in wafer version**

**Master Instruction**

All rights reserved. It is prohibited to reproduce this documentation, or any part thereof, without the prior written authorisation of Schneider Electric Systems USA, Inc.

Copyright 2019-2020 Schneider Electric Systems USA, Inc.

1	Safety instructions	5
1.1	Intended use	5
1.2	Certification	5
1.3	Safety instructions from the manufacturer	6
1.3.1	Copyright and data protection	6
1.3.2	Disclaimer	6
1.3.3	Product liability and warranty	7
1.3.4	Information concerning the documentation	7
1.3.5	Warnings and symbols used	8
1.4	Safety instructions for the operator	8
2	Device description	9
2.1	Scope of delivery	9
2.2	Device description	10
2.3	Nameplate (example)	11
3	Installation	12
3.1	General notes on installation	12
3.2	Storage	12
3.3	Transport	12
3.4	Pre-installation requirements	13
3.5	General requirements	13
3.5.1	Vibration	13
3.5.2	Magnetic field	13
3.6	Installation conditions	14
3.6.1	Inlet and outlet	14
3.6.2	Bends in 2 or 3 dimensions	14
3.6.3	T-section	15
3.6.4	Bends	15
3.6.5	Open feed or discharge	16
3.6.6	Flange deviation	16
3.6.7	Pump	16
3.6.8	Control valve	17
3.6.9	Air venting and vacuum forces	17
3.6.10	Mounting position	18
3.7	Mounting	18
3.7.1	Torques and pressures	18

4 Electrical connections	20
<hr/>	
4.1 Safety instructions.....	20
4.2 Grounding .....	20
4.3 Virtual reference for IMT33A (4, N and H version).....	22
4.4 Connection diagrams .....	22
5 Service	23
<hr/>	
5.1 Spare parts availability.....	23
5.2 Availability of services .....	23
5.3 Returning the device to the manufacturer.....	23
5.3.1 General information.....	23
5.3.2 Preapproval form - Customer returned process-wetted products.....	24
5.4 Disposal .....	25
6 Technical data	26
<hr/>	
6.1 Measuring principle.....	26
6.2 Technical data.....	27
6.3 Measuring accuracy .....	31
6.4 Dimensions and weights .....	32
7 Notes	35
<hr/>	

## 1.1 Intended use

**CAUTION!**

*Responsibility for the use of the measuring devices with regard to suitability, intended use and corrosion resistance of the used materials against the measured fluid lies solely with the operator.*

**NOTICE!**

*The manufacturer is not liable for any damage resulting from improper use or use for other than the intended purpose.*

This electromagnetic flowmeter is designed exclusively to measure the flow of electrically conductive, liquid media.

**WARNING!**

*If the device is not used according to the operating conditions (refer to chapter Technical data), the intended protection could be affected.*

## 1.2 Certification

CE marking



The manufacturer certifies successful testing of the product by applying the CE marking.

**This device fulfils the statutory requirements of the relevant EU directives.**

For full information of the EU directives and standards and the approved certifications, please refer to the EU Declaration of Conformity or the website of the manufacturer.

**DANGER!**

*For devices used in hazardous areas, additional safety notes apply. Please refer to the Ex documentation.*

## 1.3 Safety instructions from the manufacturer

### 1.3.1 Copyright and data protection

The contents of this document have been created with great care. Nevertheless, we provide no guarantee that the contents are correct, complete or up-to-date.

The contents and works in this document are subject to copyright. Contributions from third parties are identified as such. Reproduction, processing, dissemination and any type of use beyond what is permitted under copyright requires written authorisation from the respective author and/or the manufacturer.

The manufacturer tries always to observe the copyrights of others, and to draw on works created in-house or works in the public domain.

The collection of personal data (such as names, street addresses or e-mail addresses) in the manufacturer's documents is always on a voluntary basis whenever possible. Whenever feasible, it is always possible to make use of the offerings and services without providing any personal data.

We draw your attention to the fact that data transmission over the Internet (e.g. when communicating by e-mail) may involve gaps in security. It is not possible to protect such data completely against access by third parties.

We hereby expressly prohibit the use of the contact data published as part of our duty to publish an imprint for the purpose of sending us any advertising or informational materials that we have not expressly requested.

### 1.3.2 Disclaimer

The manufacturer will not be liable for any damage of any kind by using its product, including, but not limited to direct, indirect or incidental and consequential damages.

This disclaimer does not apply in case the manufacturer has acted on purpose or with gross negligence. In the event any applicable law does not allow such limitations on implied warranties or the exclusion of limitation of certain damages, you may, if such law applies to you, not be subject to some or all of the above disclaimer, exclusions or limitations.

Any product purchased from the manufacturer is warranted in accordance with the relevant product documentation and our Terms and Conditions of Sale.

The manufacturer reserves the right to alter the content of its documents, including this disclaimer in any way, at any time, for any reason, without prior notification, and will not be liable in any way for possible consequences of such changes.

### 1.3.3 Product liability and warranty

The operator shall bear responsibility for the suitability of the device for the specific purpose. The manufacturer accepts no liability for the consequences of misuse by the operator. Improper installation or operation of the devices (systems) will cause the warranty to be void. The respective "Standard Terms and Conditions" which form the basis for the sales contract shall also apply.

### 1.3.4 Information concerning the documentation

To prevent any injury to the user or damage to the device it is essential that you read the information in this document and observe applicable national standards, safety requirements and accident prevention regulations.

If this document is not in your native language and if you have any problems understanding the text, we advise you to contact your local office for assistance. The manufacturer can not accept responsibility for any damage or injury caused by misunderstanding of the information in this document.

This document is provided to help you establish operating conditions, which will permit safe and efficient use of this device. Special considerations and precautions are also described in the document, which appear in the form of icons as shown below.

## 1.3.5 Warnings and symbols used

Safety warnings are indicated by the following symbols.

**DANGER!**

*This information refers to the immediate danger when working with electricity.*

**DANGER!**

*This warning refers to the immediate danger of burns caused by heat or hot surfaces.*

**DANGER!**

*These warnings must be observed without fail. Even partial disregard of this warning can lead to serious health problems and even death. There is also the risk of seriously damaging the device or parts of the operator's plant.*

**WARNING!**

*Disregarding this safety warning, even if only in part, poses the risk of serious health problems. There is also the risk of damaging the device or parts of the operator's plant.*

**CAUTION!**

*Disregarding these instructions can result in damage to the device or to parts of the operator's plant.*

**NOTICE!**

*These instructions contain important information for the handling of the device.*

**LEGAL NOTICE!**

*This note contains information on statutory directives and standards.*

• **HANDLING**

This symbol designates all instructions for actions to be carried out by the operator in the specified sequence.

➔ **RESULT**

This symbol refers to all important consequences of the previous actions.

## 1.4 Safety instructions for the operator

**WARNING!**

*In general, devices from the manufacturer may only be installed, commissioned, operated and maintained by properly trained and authorized personnel.*

*This document is provided to help you establish operating conditions, which will permit safe and efficient use of this device.*



## 2.1 Scope of delivery



**NOTICE!**

*Do a check of the packing list to make sure that you have all the elements given in the order.*



**NOTICE!**

*Inspect the packaging carefully for damages or signs of rough handling. Report damage to the carrier and to the local office of the manufacturer.*



**NOTICE!**

*The remote version will arrive in two cartons. One carton contains the signal transmitter and one carton contains the flow tube.*

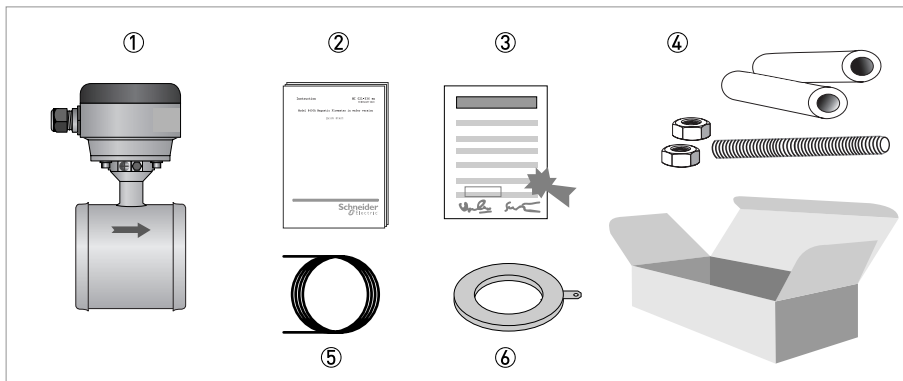

Figure 2-1: Scope of delivery

- ① Ordered flowmeter
- ② Product documentation
- ③ Factory calibration report
- ④ Mounting material (rubber sleeves). Optional; studs and bolts.
- ⑤ Signal cable (remote versions only)
- ⑥ Grounding rings (optional)



**NOTICE!**

*Assembly materials and tools are not part of the delivery. Use the assembly materials and tools in compliance with the applicable occupational health and safety directives.*

## 2.2 Device description

Electromagnetic flowmeters are designed exclusively to measure the flow and conductivity of electrically conductive, liquid media.

Your measuring device is supplied ready for operation. The factory settings for the operating data have been made in accordance with your order specifications.

### The following versions are available:

- Compact version (the signal transmitter is mounted directly on the flow tube)
- Remote version (a flow tube with a connection box and a separate signal transmitter, connected via field current- and signal cable)

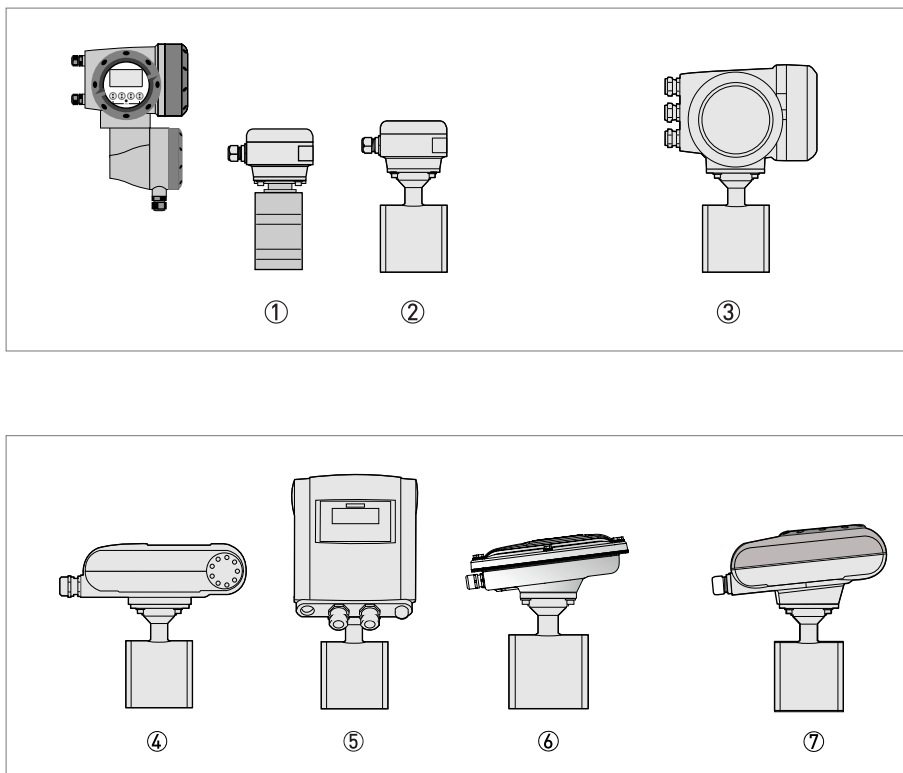

Figure 2-2: Device versions

- ① Remote version (DN10...40 - 3/8...1 1/2")
- ② Remote version (DN50...150 - 2...6")
- ③ Compact version with signal transmitter IMT33A
- ④ Compact version with signal transmitter IMT31A (0°)
- ⑤ Compact version with signal transmitter IMT31A (45°)
- ⑥ Compact version with stainless steel signal transmitter IMT31A (10°)
- ⑦ Compact version with signal transmitter IMT30A (10°)

## 2.3 Nameplate (example)



### NOTICE!

Check the device nameplate to ensure that the device is delivered according to your order. Additional information (e.g. correct supply voltage), can be found in the documentation of the transmitter.

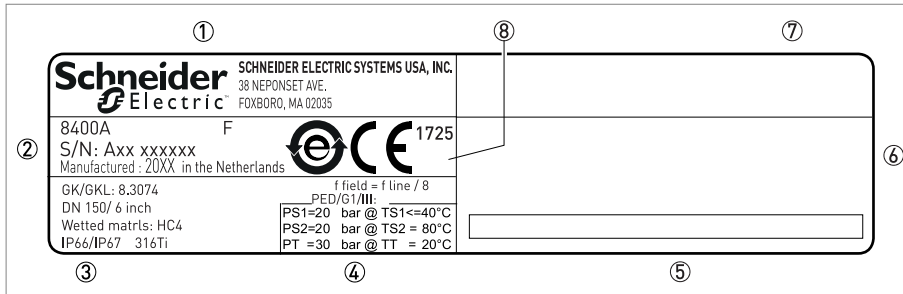

Figure 2-3: Example of nameplate

- ① Name and address of the manufacturer
- ② Type designation of the flowmeter and manufacturing date
- ③ Calibration data, size and protection class
- ④ PED data
- ⑤ Tag number
- ⑥ Additional information
- ⑦ Ambient temperature range
- ⑧ CE sign with number(s) of notified body/bodies / Disposal logo

### 3.1 General notes on installation

**NOTICE!**

*Inspect the packaging carefully for damages or signs of rough handling. Report damage to the carrier and to the local office of the manufacturer.*

**NOTICE!**

*Do a check of the packing list to make sure that you have all the elements given in the order.*

**NOTICE!**

*Look at the device nameplate to ensure that the device is delivered according to your order. Check for the correct supply voltage printed on the nameplate.*

### 3.2 Storage

- Store the device in a dry and dust-free location.
- Avoid lasting direct exposure to the sun.
- Store the device in its original packaging.
- Storage temperature: -50...+70°C / -58...+158°F

### 3.3 Transport

#### Signal converter

- No special requirements.

#### Compact version

- Do not lift the device by the signal converter housing.
- Do not use lifting chains.
- To transport the device, use lifting straps.

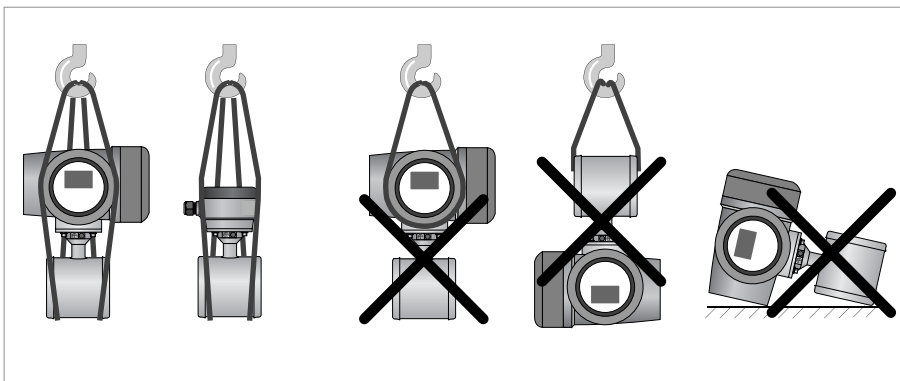

Figure 3-1: Transport

### 3.4 Pre-installation requirements

Make sure that you have all necessary tools available:

- Allen key (4 mm)
- Small screwdriver
- Wrench for cable glands
- Wrench for wall mounting bracket (remote version only)
- Torque wrench for installing flowmeter in pipeline

### 3.5 General requirements



**NOTICE!**

*The following precautions must be taken to ensure reliable installation.*

- *Make sure that there is adequate space to the sides.*
- *Protect the signal converter from direct sunlight and install a sun shade if necessary.*
- *Signal converters installed in control cabinets require adequate cooling, e.g. by fan or heat exchanger.*
- *Do not expose the signal converter to intense vibration. The flowmeters are tested for a vibration level in accordance with EN/IEC 60068-2-64.*

#### 3.5.1 Vibration

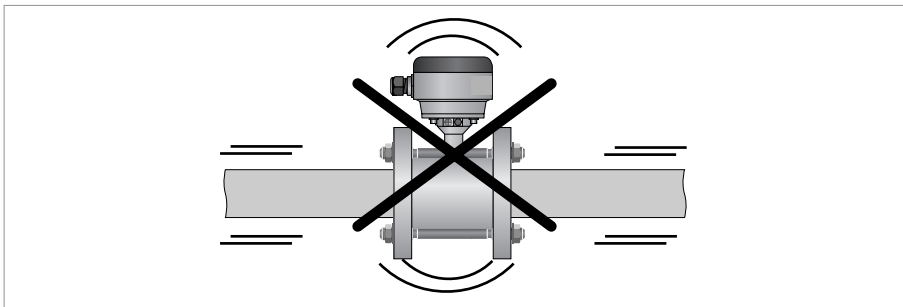

Figure 3-2: Avoid vibrations

#### 3.5.2 Magnetic field

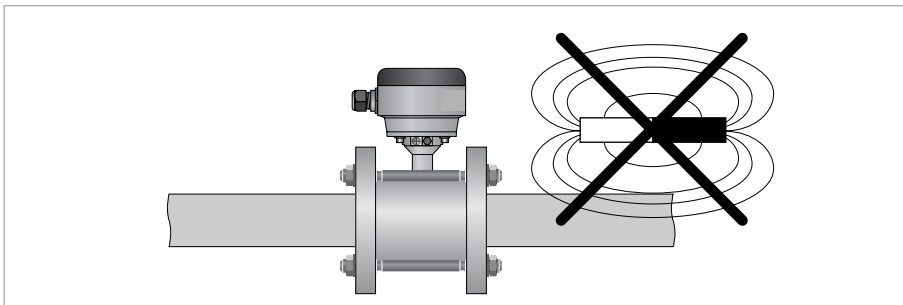

Figure 3-3: Avoid magnetic fields

## 3.6 Installation conditions

### 3.6.1 Inlet and outlet

Use straight inlet and outlet pipe sections to prevent flow distortion or swirl, caused by bends and T- sections

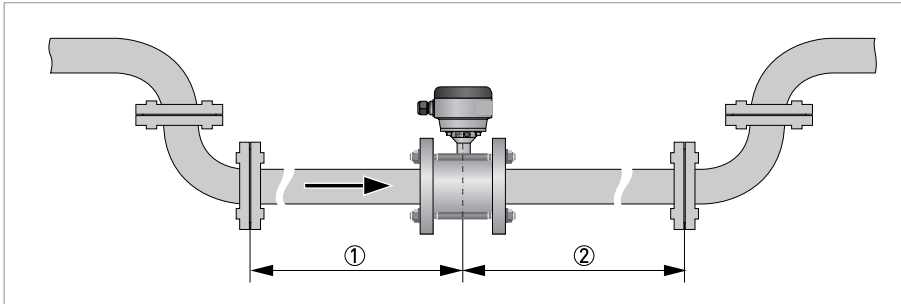

Figure 3-4: Recommended inlet and outlet section

- ① Refer to chapter "Bends in 2 or 3 dimensions"
- ②  $\geq 2$  DN

### 3.6.2 Bends in 2 or 3 dimensions

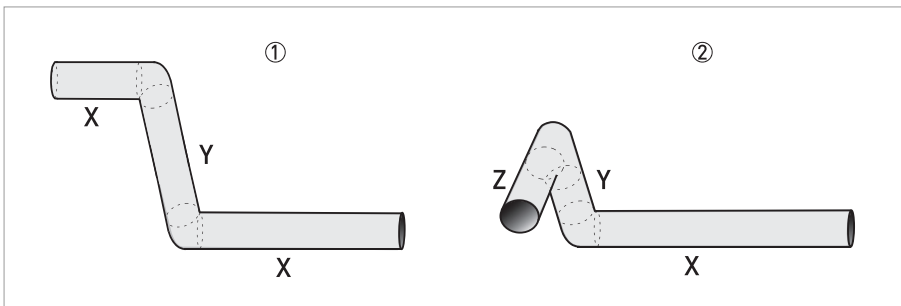

Figure 3-5: 2 and/or 3 dimensional bends upstream of the flowmeter

- ① 2 dimensions = X/Y
  - ② 3 dimensions = X/Y/Z
- Inlet length: using bends in 2 dimensions:  $\geq 5$  DN; when having bends in 3 dimensions:  $\geq 10$  DN



**NOTICE!**

2 dimensional bends occur in a vertical **or** horizontal plane (X/Y) only, while 3 dimensional bends occur in both vertical **and** horizontal plane (X/Y/Z).

### 3.6.3 T-section

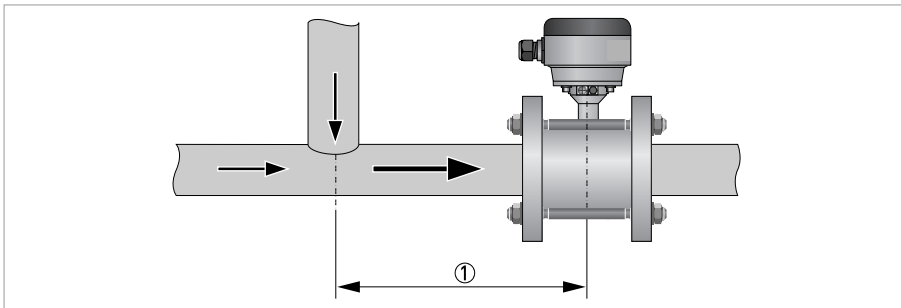

Figure 3-6: Distance behind a T-section

①  $\geq 10$  DN

### 3.6.4 Bends

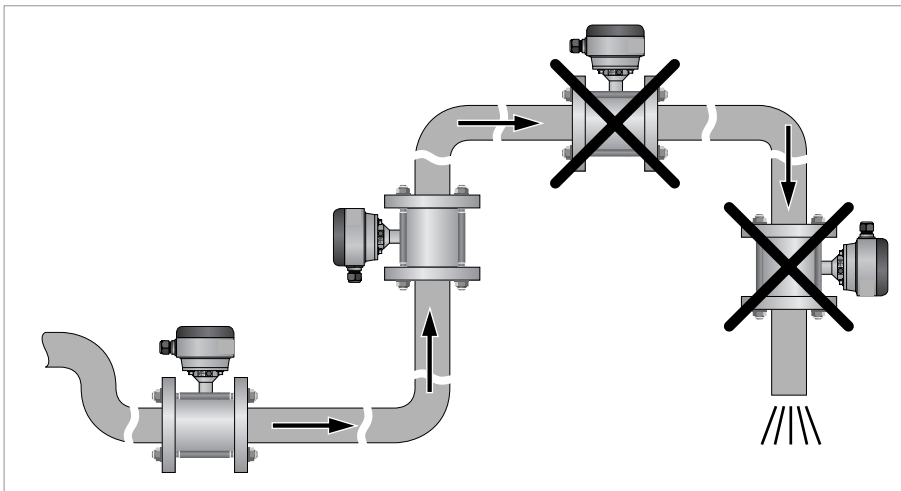

Figure 3-7: Installation in bending pipes (90°)

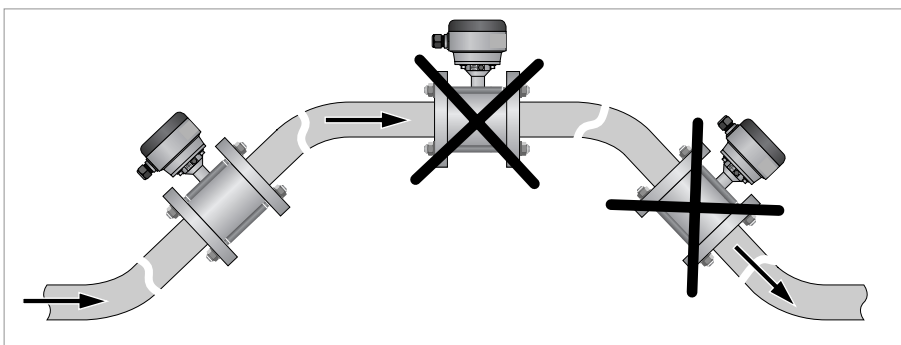

Figure 3-8: Installation in bending pipes (45°)



**CAUTION!**

*Avoid draining or partial filling of the flow tube*

3.6.5 Open feed or discharge

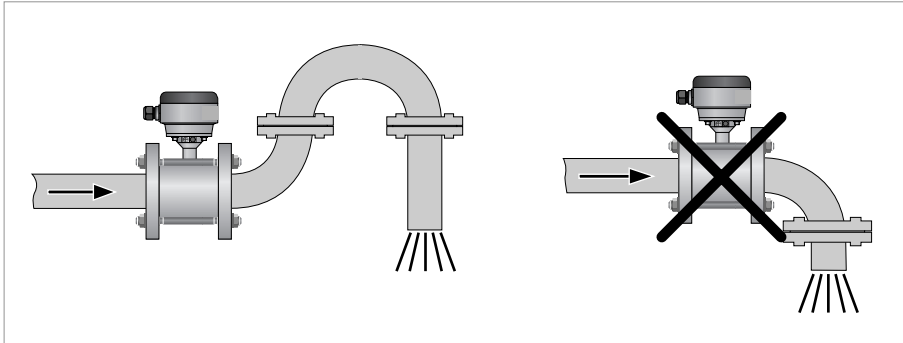

Figure 3-9: Installation in front of an open discharge

3.6.6 Flange deviation



**CAUTION!**

Max. permissible deviation of pipe flange faces:

$$L_{max} - L_{min} \leq 0.5 \text{ mm} / 0.02''$$

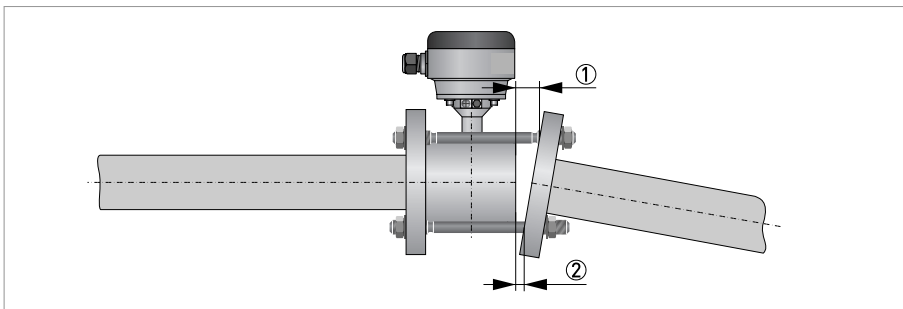

Figure 3-10: Flange deviation

- ① L<sub>max</sub>
- ② L<sub>min</sub>

3.6.7 Pump

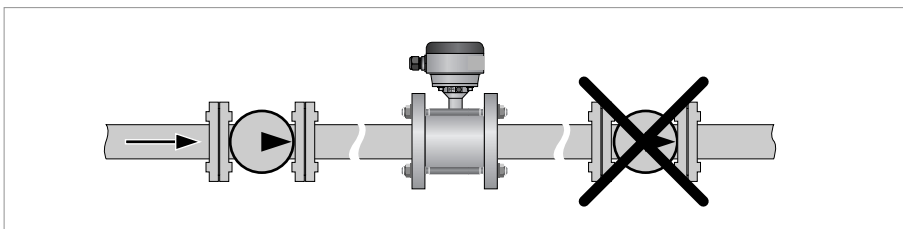

Figure 3-11: Installation behind a pump



### 3.6.8 Control valve

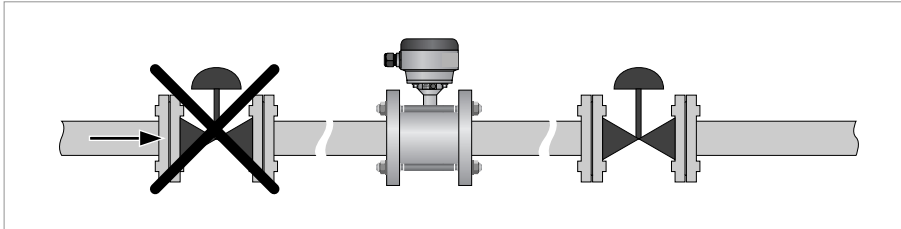

Figure 3-12: Installation in front of a control valve

### 3.6.9 Air venting and vacuum forces

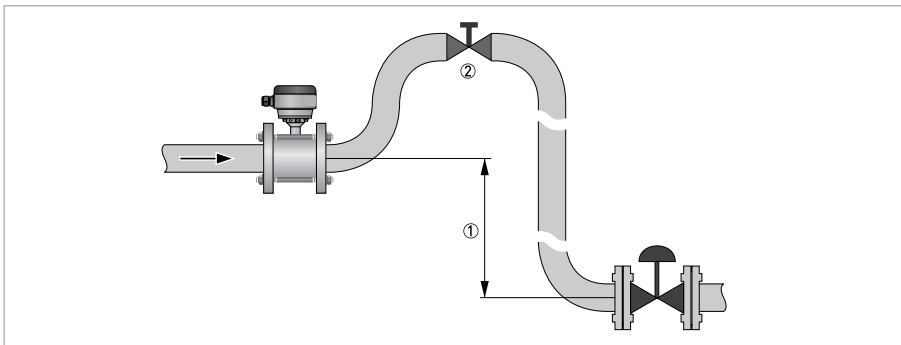

Figure 3-13: Air venting

- ①  $\geq 5$  m / 17 ft
- ② Air ventilation point

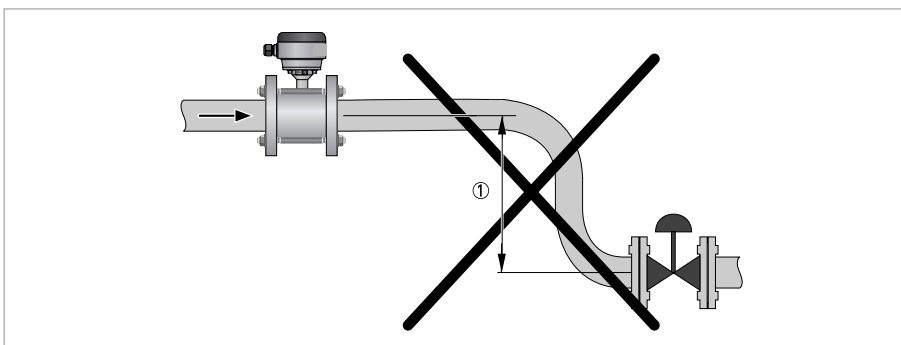

Figure 3-14: Vacuum

- ①  $\geq 5$  m / 17 ft

### 3.6.10 Mounting position

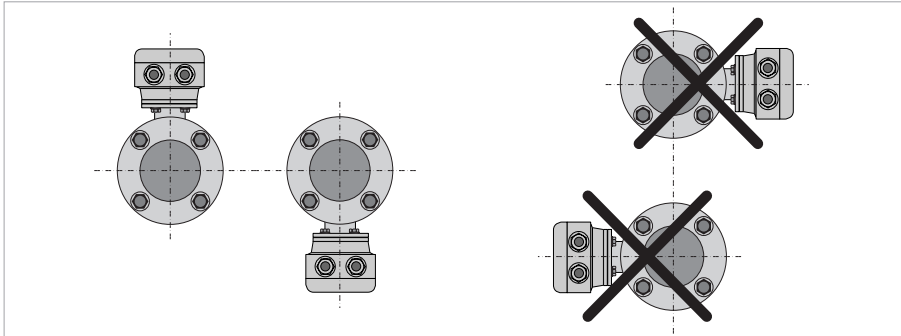

Figure 3-15: Mounting position

## 3.7 Mounting

### 3.7.1 Torques and pressures

The maximum pressure and torques values for the flowmeter are theoretical and calculated for optimum conditions and use with carbon steel flanges.

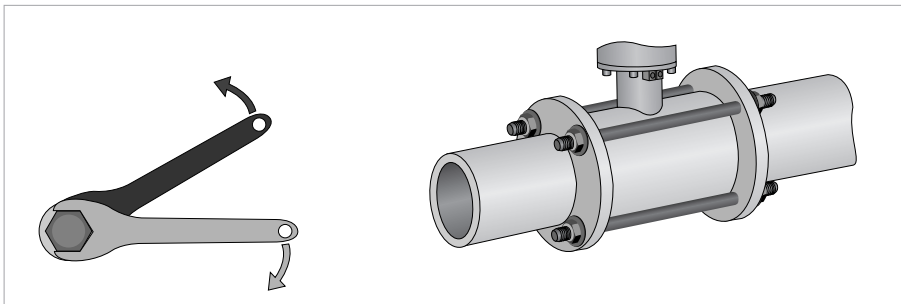

Figure 3-16: Tightening of bolts



#### Tightening of bolts

- Always tighten the bolts uniformly and in diagonally opposite sequence.
- Do not exceed the maximum torque value.
- Step 1: Apply approx. 50% of max. torque given in table.
- Step 2: Apply approx. 80% of max. torque given in table.
- Step 3: Apply 100% of max. torque given in table.

## EN 1092-1

Nominal size DN [mm]	Counter flanges		Max. operating pressure [bar]	Bolts	Max. torque [Nm] ②
	Flange size DN [mm]	Flange class [lb]			
10	15 ①	PN 16/40	≤16	4 x M12	16
15	15	PN 16/40	≤16	4 x M12	16
25	25	PN 16/40	≤16	4 x M12	16
40	40	PN 16/40	≤16	4 x M16	25
50	50	PN 16/40	≤16	4 x M16	45
80	80	PN 16/40	≤16	4 x M16	25
100	100	PN 16	≤16	8 x M16	33
100	100	PN 40	≤16	8 x M20	33
150	150	PN 16	≤16	8 x M20	82
150	150	PN 40	≤16	8 x M24	82

① For DN10 and 15 sizes use DN15 counter (pipe) flanges.

② The specified torque values are dependent on variables (temperature, bolt material, gasket material, lubricants, etc.) which are not within the control of the manufacturer. Therefore the values should be regarded as indicative only.

## ASME B16.5

Nominal size DN [inch]	Counter flanges		Max. operating pressure [psig]	Bolts	Max. torque [lbs.ft] ②
	Flange size DN [inch]	Flange class [lb]			
3/8"	1/2" ①	150/300 lb	230	4 x 1/2"	11.6
1/2"	1/2"	150/300 lb	230	4 x 1/2"	11.6
1"	1"	150/300 lb	230	4 x 1/2"	10.8
1 1/2"	1 1/2"	150/300 lb	230	4 x 1/2"	18.1
2"	2"	150/300 lb	230	4 x 5/8"	32.5
3"	3"	150 lb	230	4 x 5/8"	40.5
3"	3"	300 lb	230	8 x 5/8"	20.5
4"	4"	150/300 lb	230	8 x 5/8"	26
6"	6"	150 lb	230	8 x 3/4"	72.3
6"	6"	300 lb	230	12 x 3/4"	47.7

① For DN3/8" and 1/2" use DN1/2" counter (pipe) flanges.

② The specified torque values are dependent on variables (temperature, bolt material, gasket material, lubricants, etc.) which are not within the control of the manufacturer. Therefore the values should be regarded as indicative only.

**CAUTION!**

- Pressures are applicable at 20° C / 68° F.
- For higher temperatures, the pressure ratings are as per ASME B16.5.

## 4.1 Safety instructions



**DANGER!**

All work on the electrical connections may only be carried out with the power disconnected.  
Take note of the voltage data on the nameplate!



**DANGER!**

Observe the national regulations for electrical installations!



**WARNING!**

Observe without fail the local occupational health and safety regulations.  
Any work done on the electrical components of the measuring device may only be carried out by properly trained specialists.



**NOTICE!**

Look at the device nameplate to ensure that the device is delivered according to your order.  
Check for the correct supply voltage printed on the nameplate.

## 4.2 Grounding



**DANGER!**

The device must be grounded in accordance with regulations in order to protect personnel against electric shocks.

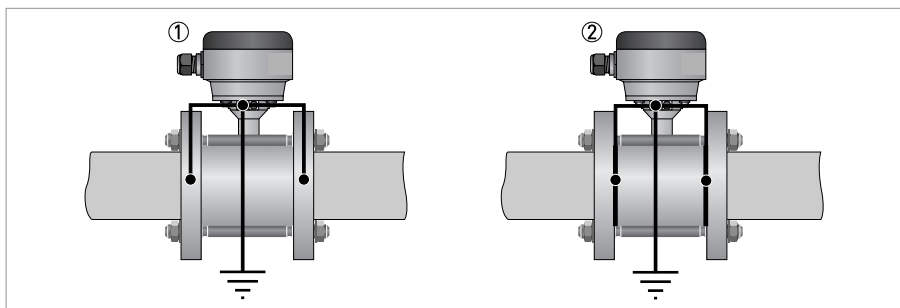

Figure 4-1: Grounding

- ① Metal pipelines, not internally coated. Grounding without grounding rings!
- ② Metal pipelines with internal coating and non-conductive pipelines. Grounding with grounding rings!

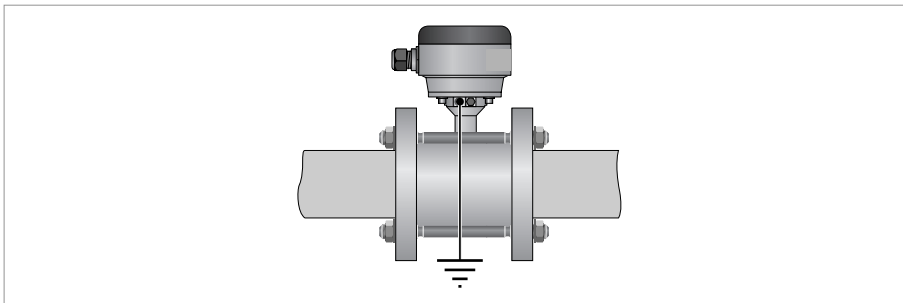

Figure 4-2: Build-in grounding rings for DN10-15 / 3/8 - 1/2 "



**NOTICE!**

*For diameter DN10 / 3/8" and DN15 / 1/2", grounding rings are integrated as standard in the tube construction.*

### Grounding rings



Figure 4-3: Grounding ring number 1

**Grounding ring number 1 (optional for DN25...150 / 1...6"):** Thickness: 3 mm / 0.1"

### 4.3 Virtual reference for IMT33A (4, N and H version)

The virtual reference option on the flow converter provides complete isolation of the measurement circuit.

**Benefits of virtual reference:**

- Grounding rings or grounding electrodes can be omitted.
- Safety increases by reducing the number of potential leakage points.
- The installation of the flowmeters is much easier.

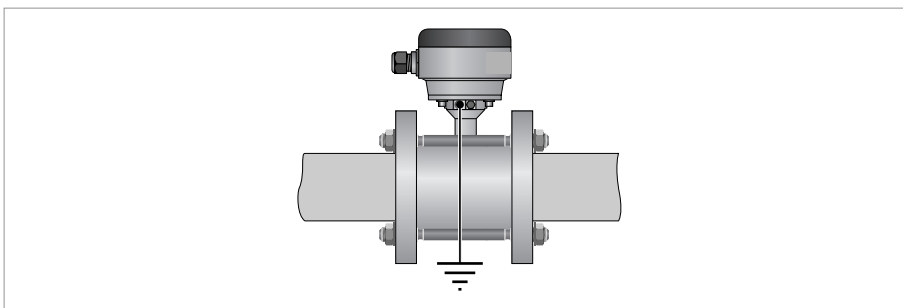

Figure 4-4: Virtual reference

**Minimum requirements:**

- Size:  $\geq$  DN10 / 3/8"
- Electrical conductivity:  $\geq$  200  $\mu$ S/cm
- Electrode cable: max. 50 m / 164 ft, type DS

### 4.4 Connection diagrams



**NOTICE!**

*For the connection diagrams, please refer to the documentation of the applicable converter.*

## 5.1 Spare parts availability

The manufacturer adheres to the basic principle that functionally adequate spare parts for each device or each important accessory part will be kept available for a period of 3 years after delivery of the last production run for the device.

This regulation only applies to spare parts which are subject to wear and tear under normal operating conditions.

## 5.2 Availability of services

The manufacturer offers a range of services to support the customer after expiration of the warranty. These include repair, maintenance, technical support and training.



### **NOTICE!**

*For more precise information, please contact your local sales office.*

## 5.3 Returning the device to the manufacturer

### 5.3.1 General information

This device has been carefully manufactured and tested. If installed and operated in accordance with these operating instructions, it will rarely present any problems.



### **WARNING!**

*Should you nevertheless need to return a device for inspection or repair, please pay strict attention to the following points:*

- *Due to statutory regulations on environmental protection and safeguarding the health and safety of the personnel, the manufacturer may only handle, test and repair returned devices that have been in contact with products without risk to personnel and environment.*
- *This means that the manufacturer can only service this device if it is accompanied by the following certificate (see next section) confirming that the device is safe to handle.*



### **WARNING!**

*If the device has been operated with toxic, caustic, radioactive, flammable or water-endangering products, you are kindly requested:*

- *to check and ensure, if necessary by rinsing or neutralising, that all cavities are free from such dangerous substances,*
- *to enclose a certificate with the device confirming that it is safe to handle and stating the product used.*

## 5.3.2 Preapproval form - Customer returned process-wetted products

**LEGAL NOTICE!**

*In compliance with U.S. Federal OSHA Standard 29CFR1910.1200 process information must be reviewed previous to receiving authorization to return material to Schneider Electric Systems USA, Inc.*

**NO PRODUCT EXPOSED TO HYDROFLUORIC ACID OR MERCURY WILL BE ACCEPTED!**

Date: \_\_\_\_\_

**Customer information**

Customer's name:

Address:

Phone no:

Fax no.:

Contact's name:

**Rep information**

Rep's name:

Address:

Phone no:

Fax no.:

Contacts' name:

Product being returned:

Model No.:

Serial no.:

**Under warranty?**

**YES**

**NO**

**Copies of MSDS sheets for all processes including cleaning solutions may be required.**

Type of process (what chemicals/materials were processed through the unit):

Explain what steps were taken to decontaminate the unit: (was unit steam cleaned, rinsed out with water, chemically cleaned etc.)

Form completed by:

\_\_\_\_\_

Print name

\_\_\_\_\_

Signature

Date: \_\_\_\_\_



**CLEANING STATEMENT**

(Note: Your item will not be serviced unless the following cleaning statement has been signed):

I certify that the above referenced item has been properly purged and cleaned, complies with U.S. Department of Transportation shipping requirements and DOES NOT present a health and/or safety hazard (as defined by OSHA) to our Customer Repair personnel.

Print name: \_\_\_\_\_

Signature: \_\_\_\_\_

Print title: \_\_\_\_\_

Date: \_\_\_\_\_

Please fax the completed form to the Customer Satisfaction Center +1-508-549-4999

**5.4 Disposal****LEGAL NOTICE!**

*Disposal must be carried out in accordance with legislation applicable in your country.*

**Separate collection of WEEE (Waste Electrical and Electronic Equipment) in the European Union:**

According to the directive 2012/19/EU, the monitoring and control instruments marked with the WEEE symbol and reaching their end-of-life **must not be disposed of with other waste**. The user must dispose of the WEEE to a designated collection point for the recycling of WEEE or send them back to our local organisation or authorised representative.

## 6.1 Measuring principle

An electrically conductive fluid flows inside an electrically insulated pipe through a magnetic field. This magnetic field is generated by a current, flowing through a pair of field coils.

Inside of the fluid, a voltage  $U$  is generated:

$$U = v * k * B * D$$

in which:

$v$  = mean flow velocity

$k$  = factor correcting for geometry

$B$  = magnetic field strength

$D$  = inner diameter of flowmeter

The signal voltage  $U$  is picked off by electrodes and is proportional to the mean flow velocity  $v$  and thus the flow rate  $Q$ . A signal transmitter is used to amplify the signal voltage, filter it and convert it into signals for totalizing, recording and output processing.

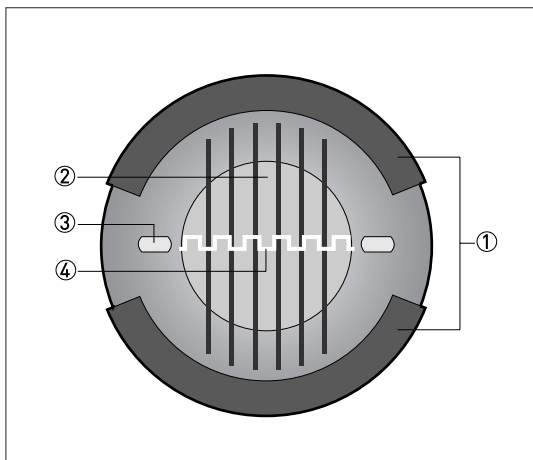

Figure 6-1: Measuring principle

- ① Field coils
- ② Magnetic field
- ③ Electrodes
- ④ Induced voltage (proportional to flow velocity)

## 6.2 Technical data



### NOTICE!

- *The following data is provided for general applications. If you require data that is more relevant to your specific application, please contact us or your local sales office.*
- *Additional information (certificates, special tools, software,...) and complete product documentation can be downloaded free of charge from the website.*

### Measuring system

Measuring principle	Faraday's law of induction
Application range	Electrically conductive fluids
<b>Measured value</b>	
Primary measured value	Flow velocity
Secondary measured value	Volume flow

### Design

Features	Wafer design
	PFA liner and Hastelloy® electrodes
	Lightweight and compact
Modular construction	The measurement system consists of a flow tube and a signal transmitter. It is available as compact and as separate version. Additional information can be found in the documentation of the signal transmitter.
Compact version	With signal transmitter IMT30A: 8400A + IMT30A 4
	With signal transmitter IMT31A: 8400A + IMT31A 4
	With signal transmitter IMT33A: 8400A + IMT33A 4
Remote version	In wall (W) mount version with signal transmitter IMT30A: 8400A + IMT30A N
	In wall (W) mount version with signal transmitter IMT31A: 8400A + IMT31A N
	In field (F) or wall (W) mount version with signal transmitter IMT33A: 8400 + IMT33A N or H
Nominal diameter	DN10...150/ 3/8...6"

### Measuring accuracy

Maximum measuring error	IMT30A: down to 0.5% of the measured value $\pm$ 1 mm/s
	IMT31A: down to 0.4% of the measured value $\pm$ 1 mm/s
	IMT33A: down to 0.3% of the measured value $\pm$ 2 mm/s
	The maximum measuring error depends on the installation conditions
	For detailed information refer to <i>Measuring accuracy</i> on page 31.
Repeatability	$\pm$ 0.1% of the measured value (mv); minimum 1 mm/s
Calibration	2 point calibration by direct volume comparison

### Operating conditions

<b>Temperature</b>	
Process temperature	-25...+120°C/ -13...+248°F
Ambient temperature	-25...+65°C/ -13...+149°F
Protect the electronics against self-heating at ambient temperatures above +55°C/ +131°F	
Storage temperature	-50...+70°C/ -58...+158°F
<b>Measuring range</b>	-12...+12 m/s / -40...+40 ft/s
<b>Pressure</b>	
Ambient pressure	Atmospheric
Operating pressure	Up to 16 bar/230 psi
Vacuum load	0 mbar/psi absolute
Pressure loss	Negligible
Pressure ranges for secondary containment	Pressure resistant up to 40 bar/580 psi
	Burst pressure up to approximately 160 bar/2320 psi
<b>Chemical properties</b>	
Physical condition	Electrically conductive liquids
Electrical conductivity	Standard: $\geq 5 \mu\text{S}/\text{cm}$
	Demineralised water: $\geq 20 \mu\text{S}/\text{cm}$
Permissible gas content (volume)	IMT30A: $\leq 3\%$
	IMT31A: $\leq 3\%$
	IMT33A: $\leq 5\%$
Permissible solid content (volume)	IMT30A: $\leq 10\%$
	IMT31A: $\leq 10\%$
	IMT33A: $\leq 70\%$

### Installation conditions

Installation	Assure that the flow tube is always fully filled
	For detailed information refer to the manual of the flow tube and signal transmitter
Flow direction	Forward and reverse
	Arrow on the flow tube indicates positive flow direction
Inlet run	$\geq 5 \text{ DN}$
Outlet run	$\geq 2 \text{ DN}$
Dimensions and weights	For detailed information refer to <i>Dimensions and weights</i> on page 32.

## Materials

Flow tube housing	DN10...40 / 3/8...1½": malleable iron (GTW-S-38-12)
	DN50...150 / 2...6": sheet steel
Measuring tube	Austenitic stainless steel
Liner	PFA
Protective coating	On exterior of the meter: housing, signal transmitter (compact version) and/or connection box (field version).
	Standard coating
Connection box	Only for remote versions
	Standard: die-cast aluminium
	Option: stainless steel
Measuring electrodes	Hastelloy® C
Grounding rings	Standard: for DN10...15 / 3/8...½": integrated in flow tube construction
	Optional: for DN25...150 / 1...6"
	Stainless steel 316L (1.4404)
	Grounding rings can be omitted with virtual reference option for the signal transmitter IMT33A
Mounting material	DN40...150 / 1½...6"
	Standard: rubber centering sleeves
	Option: galvanised steel or stainless steel stud bolts and nuts

## Process connections

Counter flanges	
EN 1092-1	DN10...80: PN 16 or PN 40 DN100...150: PN 16 (standard); PN 40 on request
ASME	3/8...6": 150 lb / RF 3/8...4": 300 lb / RF
JIS	DN10...100: JIS 20K (≤ 16 bar); DN150: JIS 10K (≤ 10 bar)

## Electrical connections

	For full detail refer to the relevant documentation of the signal transmitter
Signal cable (for remote systems only)	
Type A (DS)	<b>In combination with the signal transmitter IMT30A, IMT31A and IMT33A</b>
	Standard cable, double shielded. Max. length: 600 meter / 1968 feet (depends on electrical conductivity and flow tube)
Type B (BTS)	<b>Only in combination with the signal transmitter IMT33A</b>
	Optional cable, triple shielded. Max. length: 600 meter / 1968 feet (depends on electrical conductivity and flow tube).
I/O	For full details of I/O options, including data streams and protocols, see technical datasheet of the relevant signal transmitter.

## Approvals and certifications

<b>CE</b>	
This device fulfils the statutory requirements of the EU directives. The manufacturer certifies successful testing of the product by applying the CE mark.	
	For full information of the EU directive & standards and the approved certifications; please refer to the EU Declaration of Conformity or the website of the manufacturer.
<b>Hazardous areas</b>	
FM	<b>In combination with signal transmitter IMT33A 4 or H</b>
	Class I, Div. 2, Groups A, B, C and D.
	Class II, Div. 2, Groups F and G.
	Class III, Div. 2
CSA	<b>In combination with signal transmitter IMT33A 4 or H</b>
	Class I, Div. 2; Groups A; B; C and D
	Class II, Div. 2; Groups F and G
cCSAus OL	Valid for signal transmitter IMT31A 4/N and IMT33A 4/N/H
<b>Other approvals and standards</b>	
Custody transfer	Only in combination with signal transmitter IMT33A
	<b>Cold water</b>
	MID Annex MI-001 type examination certificate
	<b>Liquids other than water</b>
	MID Annex MI-005 type examination certificate
Protection category acc. to IEC 60529	Standard: IP66/67, NEMA 4/4X/6.
	IP67/69 with IMT31A (stainless steel) signal transmitter
Shock test	IEC 60068-2-27
	30 g for 18 ms
Vibration test	IEC 60068-2-24
	f = 20...2000 Hz, rms = 4.5 g, t = 30 min

## 6.3 Measuring accuracy

Every electromagnetic flowmeter is calibrated by direct volume comparison. The wet calibration validates the performance of the flowmeter under reference conditions against accuracy limits.

The accuracy limits of electromagnetic flowmeters are typically the result of the combined effect of linearity, zero point stability and calibration uncertainty.

### Reference conditions

- Medium: water
- Temperature: +5...+35°C / +41...+95°F
- Operating pressure: 0.1...5 barg / 1.5...72.5 psig
- Inlet section:  $\geq 5$  DN
- Outlet section:  $\geq 2$  DN

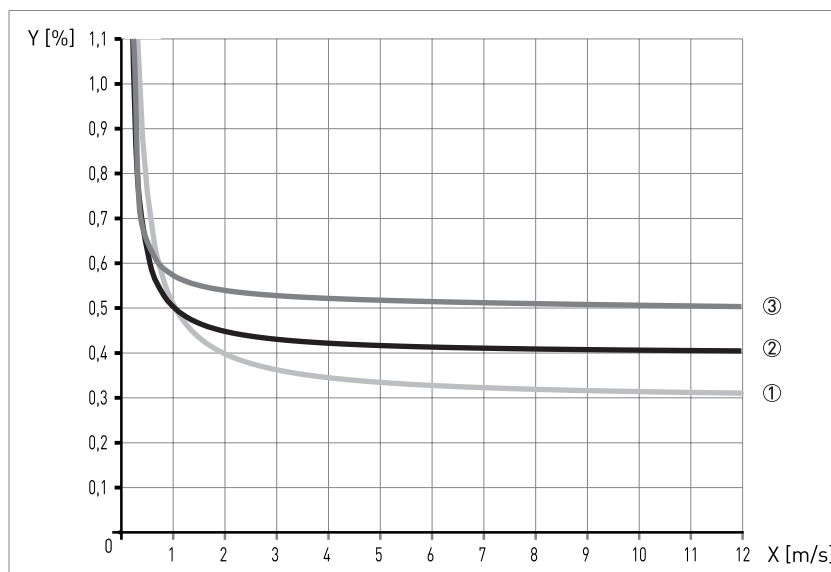

Figure 6-2: Flow velocity vs. accuracy

X [m/s]: flow velocity

Y [%]: deviation from the actual measured value (mv)

### Accuracy

Flow tube diameter	Signal transmitter type	Accuracy	Curve
DN10...150 (3/8...6")	IMT30A	0.5% of mv + 1 mm/s	③
DN10...150 (3/8...6")	IMT31A	0.4% of mv + 1 mm/s	②
DN10...150 (3/8...6")	IMT33A	0.3% of mv + 2 mm/s	①

6.4 Dimensions and weights

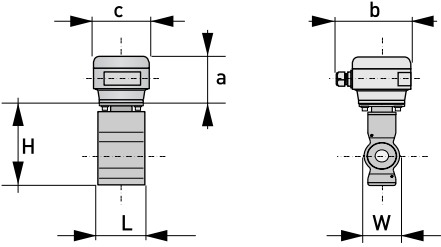
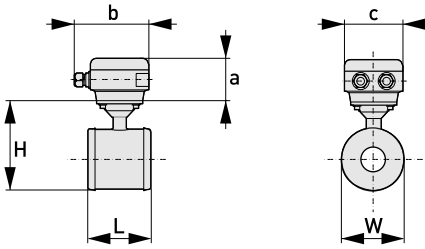
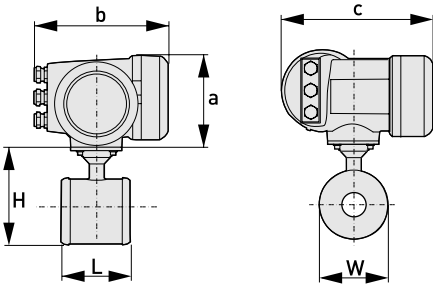
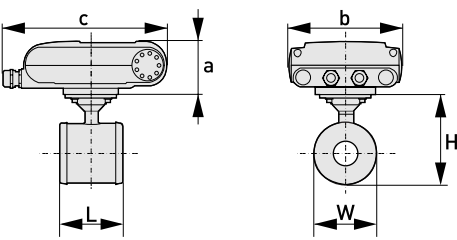
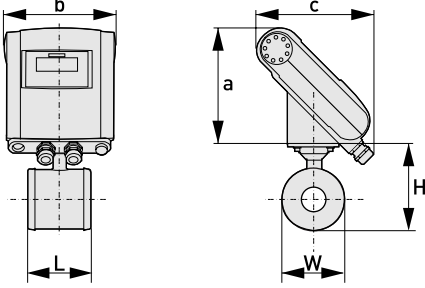
<p><b>Remote version:</b> DN10...40 / 3/8...1½"</p>		<p>a = 88 mm / 3.5"</p> <p>b = 139 mm / 5.5" ①</p> <p>c = 106 mm / 4.2"</p> <p>Total height = H + a</p>
<p><b>Remote version:</b> DN50...150 / 2...6"</p>		<p>a = 88 mm / 3.5"</p> <p>b = 139 mm / 5.5" ①</p> <p>c = 106 mm / 4.2"</p> <p>Total height = H + a</p>
<p><b>Compact version with</b> IMT33A</p>		<p>a = 155 mm / 6.1"</p> <p>b = 230 mm / 9.1" ①</p> <p>c = 260 mm / 10.2"</p> <p>Total height = H + a</p>
<p><b>Compact version with</b> IMT31A (0°)</p>		<p>a = 82 mm / 3.2"</p> <p>b = 161 mm / 6.3"</p> <p>c = 257 mm / 10.1" ①</p> <p>Total height = H + a</p>
<p><b>Compact version with</b> IMT31A (45°)</p>		<p>a = 186 mm / 7.3"</p> <p>b = 161 mm / 6.3"</p> <p>c = 184 mm / 7.3" ①</p> <p>Total height = H + a</p>

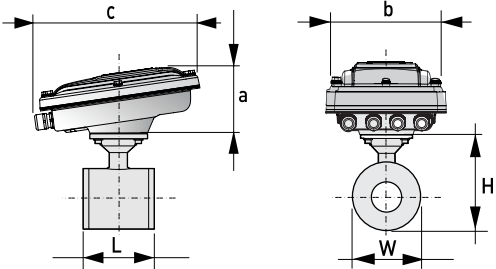
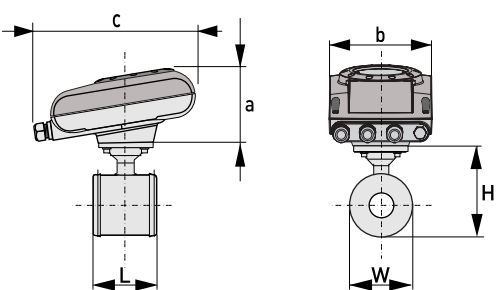

<b>Compact stainless steel version with IMT31A (10°)</b>		<p>a = 100 mm / 4"</p> <p>b = 187 mm / 7.36" ①</p> <p>c = 270 mm / 10.63"</p> <p>Total height = H + a</p>
<b>Compact version with IMT30A</b>		<p>a = 101 mm / 3.98"</p> <p>b = 157 mm / 6.18"</p> <p>c = 260 mm / 10.24" ①</p> <p>Total height = H + a</p>

① The value may vary depending on the used cable glands.

**NOTICE!**

- All data given in the following tables are based on standard versions of the flow tube only.
- Especially for smaller nominal sizes of the flow tube, the signal transmitter can be bigger than the tube.
- Note that for other pressure ratings than mentioned, the dimensions may be different.
- For full information on signal transmitter dimensions see relevant documentation.

**EN 1092-1**

Nominal size DN	Dimensions [mm]			Approx. weight [kg]
	L	H	W	
10	68	137	47	1.7
15	68	137	47	1.7
25	54	147	66	1.7
40	78	162	82	2.6
50	100	151	101	4.2
80	150	180	130	5.7
100	200	207	156	10.5
150	200	271	219	15.0

**ASME B16.5**

Nominal size ASME	Dimensions [inch]			Approx. weight [lb]
	L	H	W	
3/8"	2.68	5.39	1.85	3.7
1/2"	2.68	5.39	1.85	3.7
1"	2.13	5.79	2.6	3.7
1 1/2"	3.07	6.38	3.23	5.7
2"	3.94	5.94	3.98	9.3
3"	5.91	7.08	5.12	12.6
4"	7.87	8.15	6.14	23.1
6"	7.87	10.67	8.62	33.1



Schneider Electric Systems USA, Inc. Global Customer Support  
38 Neponset Avenue Inside U.S.: 1-866-746-6477  
Foxboro, MA 02035 Outside U.S.: 1-508-549-2424  
United States of America <https://pasupport.schneider-electric.com>  
<http://www.se.com>

Copyright 2020 Schneider Electric Systems USA, Inc.  
All rights reserved.

The Schneider Electric brand and any trademarks of  
Schneider Electric SE or its subsidiaries are the property  
of Schneider Electric SE or its subsidiaries.  
All other trademarks are the property of their respective  
owners.

