

Instruction

MI 021-536 en

FEBRUARY 2020

Model 8400A Magnetic Flowmeter in wafer version

Quick Start

1	Safety instructions	3
<hr/>		
2	Installation	4
<hr/>		
2.1	Scope of delivery.....	4
2.2	Device description	5
2.3	Nameplate (example)	6
2.4	Storage	6
2.5	Transport	7
2.6	Pre-installation requirements	7
2.7	General requirements	8
2.7.1	Vibration	8
2.7.2	Magnetic field.....	8
2.8	Installation conditions	9
2.8.1	Inlet and outlet	9
2.8.2	Bends in 2 or 3 dimensions.....	9
2.8.3	T-section	10
2.8.4	Bends	10
2.8.5	Open feed or discharge.....	11
2.8.6	Control valve	11
2.8.7	Pump	11
2.8.8	Air venting and vacuum forces	12
2.8.9	Flange deviation.....	13
2.8.10	Mounting position.....	13
2.9	Mounting.....	14
2.9.1	Torques and pressures.....	14
<hr/>		
3	Electrical connections	16
<hr/>		
3.1	Safety instructions.....	16
3.2	Grounding	16
3.3	Virtual reference for IMT33A (4, N and H version).....	18
3.4	Connection diagrams	18
<hr/>		
4	Technical data	19
<hr/>		
4.1	Dimensions and weights	19
<hr/>		
5	Notes	22
<hr/>		

Warnings and symbols used



DANGER!

This information refers to the immediate danger when working with electricity.



DANGER!

These warnings must be observed without fail. Even partial disregard of this warning can lead to serious health problems and even death.



WARNING!

Disregarding this safety warning, even if only in part, poses the risk of serious health problems. There is also the risk of damaging the device or parts of the operator's plant.



CAUTION!

Disregarding these instructions can result in damage to the device or to parts of the operator's plant.



NOTICE!

These instructions contain important information for the handling of the device.



HANDLING

- This symbol designates all instructions for actions to be carried out by the operator in the specified sequence.

➔ **RESULT**

This symbol refers to all important consequences of the previous actions.

Safety instructions for the operator



CAUTION!

Installation, assembly, start-up and maintenance may only be performed by appropriately trained personnel. The regional occupational health and safety directives must always be observed.



LEGAL NOTICE!

The responsibility as to the suitability and intended use of this device rests solely with the user. The supplier assumes no responsibility in the event of improper use by the customer. Improper installation and operation may lead to loss of warranty. In addition, the "Terms and Conditions of Sale" apply which form the basis of the purchase contract.



NOTICE!

Further information can be found on the website.

2.1 Scope of delivery

**NOTICE!**

Do a check of the packing list to make sure that you have all the elements given in the order.

**NOTICE!**

Inspect the packaging carefully for damages or signs of rough handling. Report damage to the carrier and to the local office of the manufacturer.

**NOTICE!**

The remote version will arrive in two cartons. One carton contains the signal transmitter and one carton contains the flow tube.

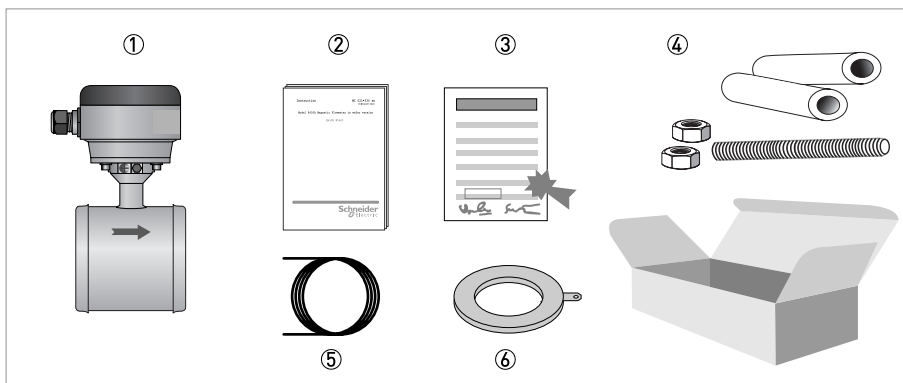

Figure 2-1: Scope of delivery

- ① Ordered flowmeter
- ② Product documentation
- ③ Factory calibration report
- ④ Mounting material (rubber sleeves). Optional; studs and bolts.
- ⑤ Signal cable (remote versions only)
- ⑥ Grounding rings (optional)

**NOTICE!**

Assembly materials and tools are not part of the delivery. Use the assembly materials and tools in compliance with the applicable occupational health and safety directives.

2.2 Device description

Electromagnetic flowmeters are designed exclusively to measure the flow and conductivity of electrically conductive, liquid media.

Your measuring device is supplied ready for operation. The factory settings for the operating data have been made in accordance with your order specifications.

The following versions are available:

- Compact version (the signal transmitter is mounted directly on the flow tube)
- Remote version (a flow tube with a connection box and a separate signal transmitter, connected via field current- and signal cable)

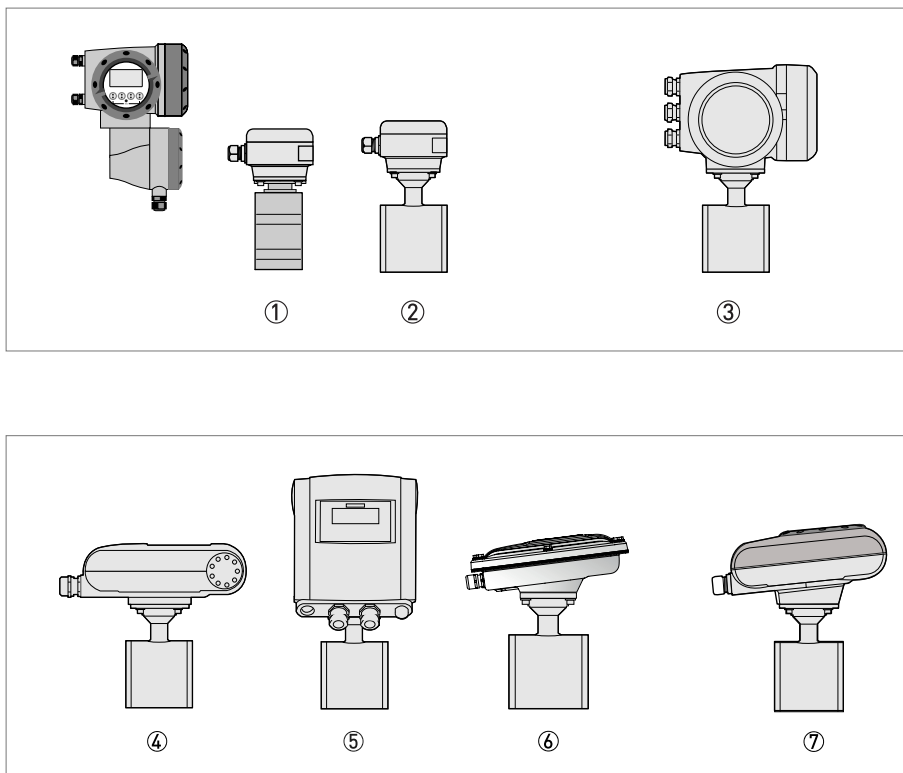

Figure 2-2: Device versions

- ① Remote version (DN10...40 - 3/8...1 1/2")
- ② Remote version (DN50...150 - 2...6")
- ③ Compact version with signal transmitter IMT33A
- ④ Compact version with signal transmitter IMT31A (0°)
- ⑤ Compact version with signal transmitter IMT31A (45°)
- ⑥ Compact version with stainless steel signal transmitter IMT31A (10°)
- ⑦ Compact version with signal transmitter IMT30A (10°)

2.3 Nameplate (example)



NOTICE!

Check the device nameplate to ensure that the device is delivered according to your order. Additional information (e.g. correct supply voltage), can be found in the documentation of the transmitter.

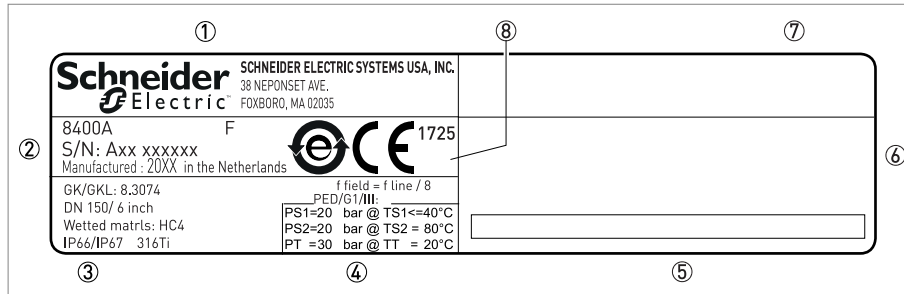

Figure 2-3: Example of nameplate

- ① Name and address of the manufacturer
- ② Type designation of the flowmeter and manufacturing date
- ③ Calibration data, size and protection class
- ④ PED data
- ⑤ Tag number
- ⑥ Additional information
- ⑦ Ambient temperature rang
- ⑧ CE sign with number(s) of notified body/bodies / Disposal logo

2.4 Storage

- Store the device in a dry and dust-free location.
- Avoid lasting direct exposure to the sun.
- Store the device in its original packaging.
- Storage temperature: -50...+70°C / -58...+158°F

2.5 Transport

Signal converter

- No special requirements.

Compact version

- Do not lift the device by the signal converter housing.
- Do not use lifting chains.
- To transport the device, use lifting straps.

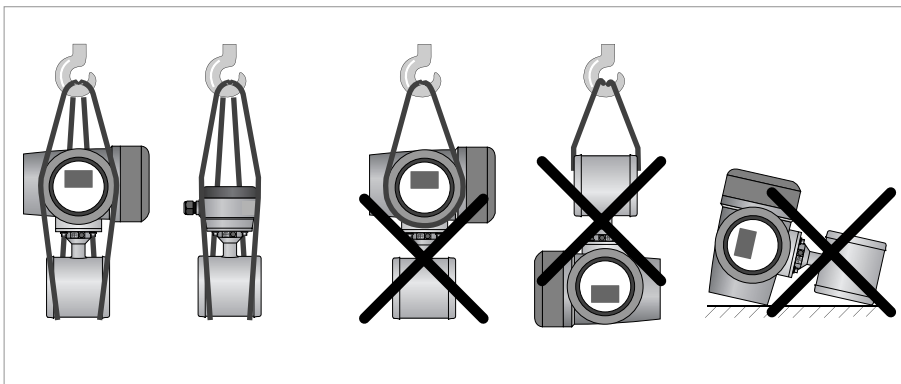

Figure 2-4: Transport

2.6 Pre-installation requirements

Make sure that you have all necessary tools available:

- Allen key (4 mm)
- Small screwdriver
- Wrench for cable glands
- Wrench for wall mounting bracket (remote version only)
- Torque wrench for installing flowmeter in pipeline

2.7 General requirements

**NOTICE!**

The following precautions must be taken to ensure reliable installation.

- Make sure that there is adequate space to the sides.
- Protect the signal converter from direct sunlight and install a sun shade if necessary.
- Signal converters installed in control cabinets require adequate cooling, e.g. by fan or heat exchanger.
- Do not expose the signal converter to intense vibration. The flowmeters are tested for a vibration level in accordance with EN/IEC 60068-2-64.

2.7.1 Vibration

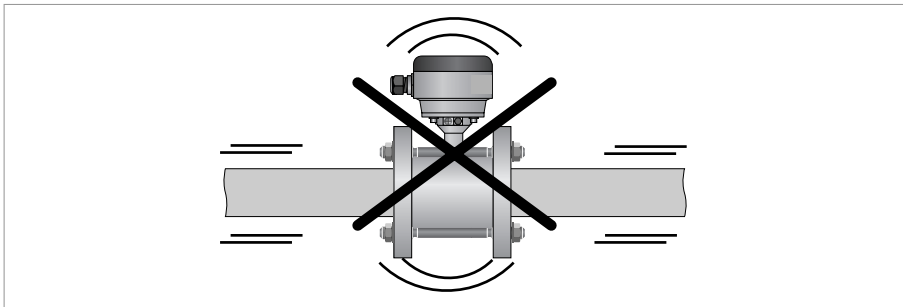

Figure 2-5: Avoid vibrations

2.7.2 Magnetic field

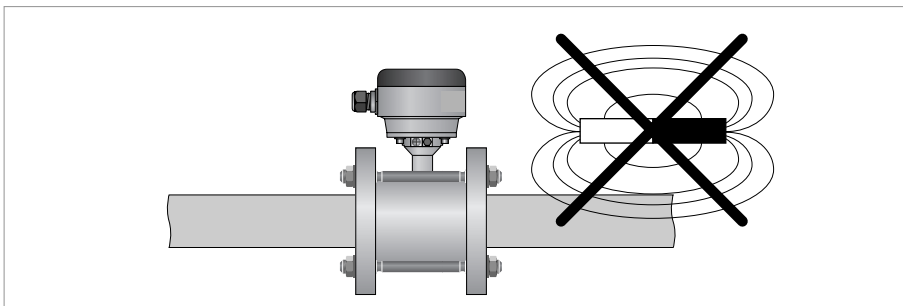

Figure 2-6: Avoid magnetic fields

2.8 Installation conditions

2.8.1 Inlet and outlet

Use straight inlet and outlet pipe sections to prevent flow distortion or swirl, caused by bends and T- sections

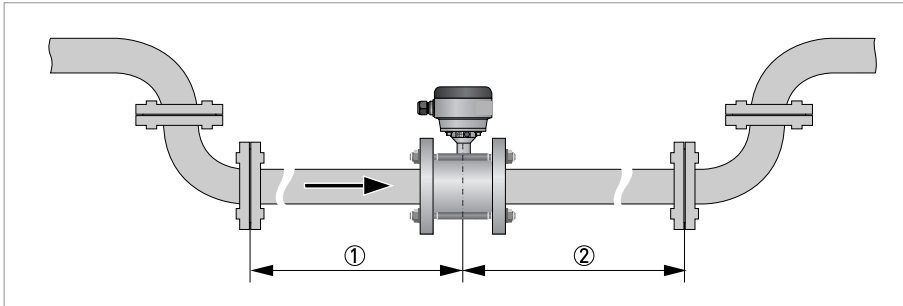

Figure 2-7: Recommended inlet and outlet section

- ① Refer to chapter "Bends in 2 or 3 dimensions"
- ② ≥ 2 DN

2.8.2 Bends in 2 or 3 dimensions

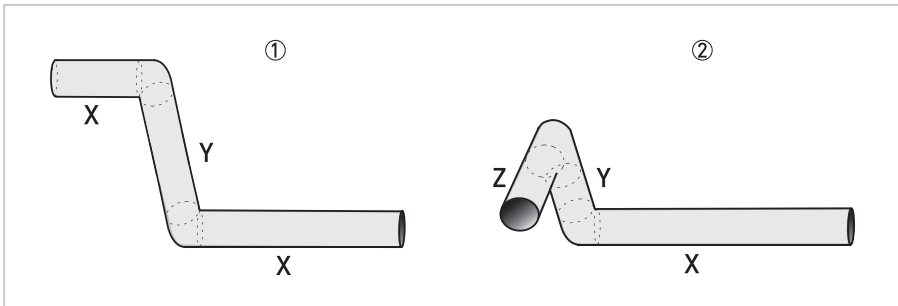

Figure 2-8: 2 and/or 3 dimensional bends upstream of the flowmeter

- ① 2 dimensions = X/Y
 - ② 3 dimensions = X/Y/Z
- Inlet length: using bends in 2 dimensions: ≥ 5 DN; when having bends in 3 dimensions: ≥ 10 DN



NOTICE!

2 dimensional bends occur in a vertical **or** horizontal plane (X/Y) only, while 3 dimensional bends occur in both vertical **and** horizontal plane (X/Y/Z).

2.8.3 T-section

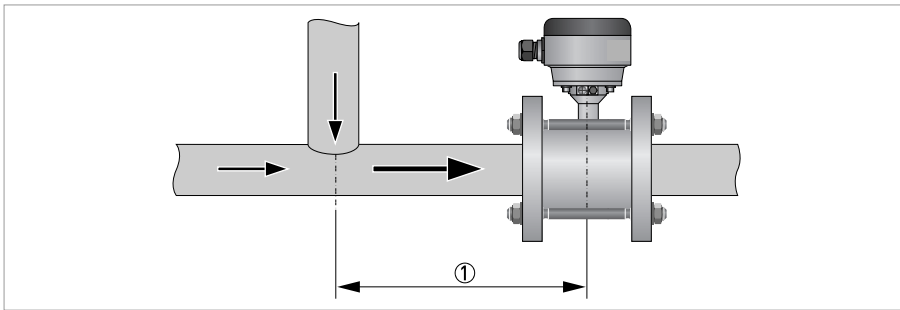

Figure 2-9: Distance behind a T-section

① ≥ 10 DN

2.8.4 Bends

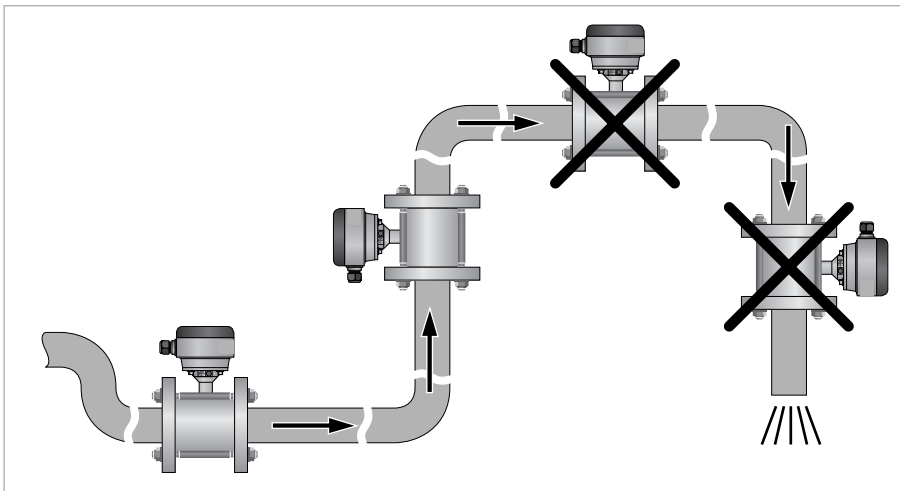

Figure 2-10: Installation in bending pipes (90°)

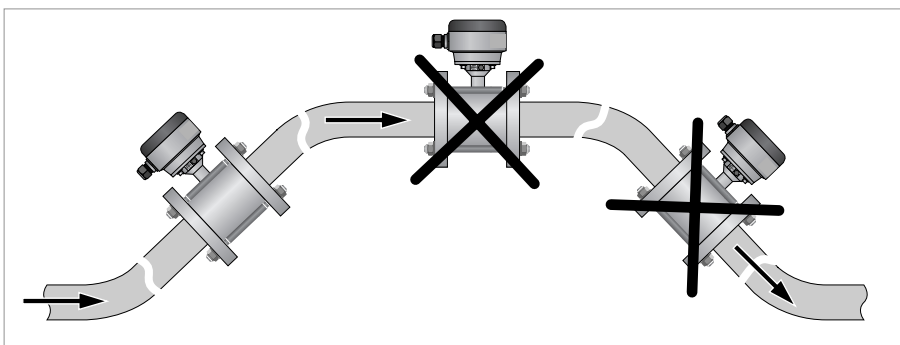

Figure 2-11: Installation in bending pipes (45°)



CAUTION!

Avoid draining or partial filling of the flow tube

2.8.5 Open feed or discharge

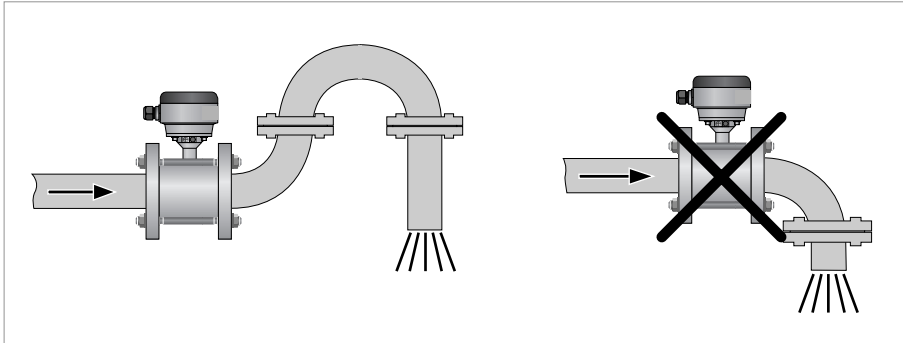

Figure 2-12: Installation in front of an open discharge

2.8.6 Control valve

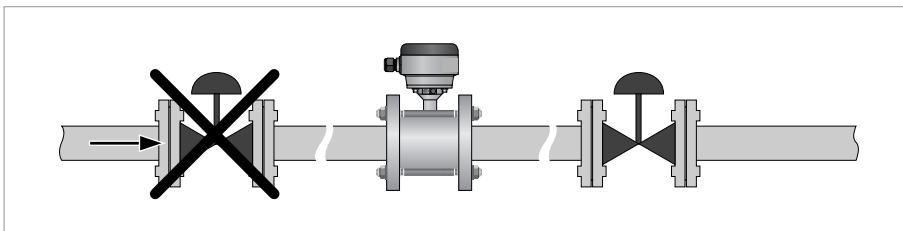

Figure 2-13: Installation in front of a control valve

2.8.7 Pump

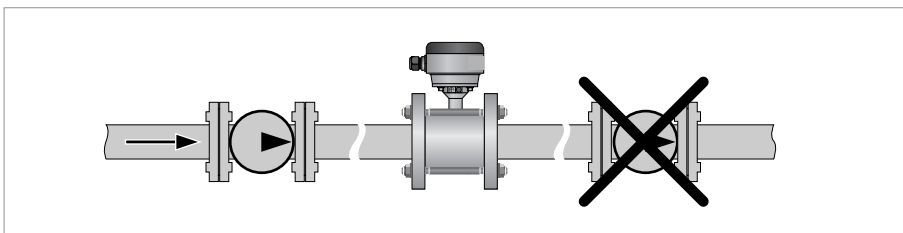

Figure 2-14: Installation behind a pump

2.8.8 Air venting and vacuum forces

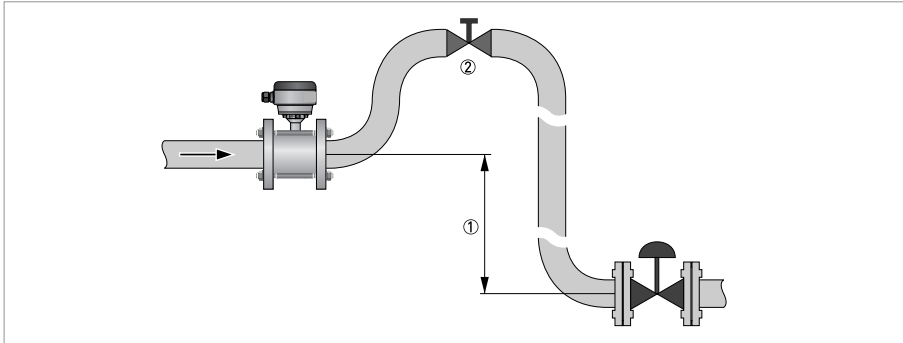

Figure 2-15: Air venting

- ① ≥ 5 m / 17 ft
- ② Air ventilation point

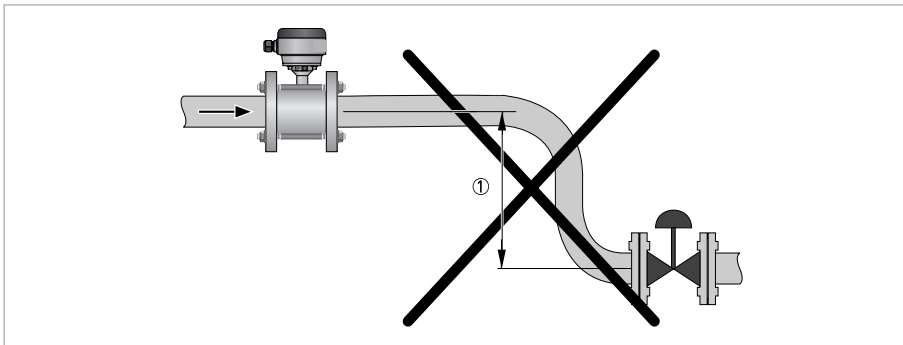

Figure 2-16: Vacuum

- ① ≥ 5 m / 17 ft

2.8.9 Flange deviation

**CAUTION!**

Max. permissible deviation of pipe flange faces:

$$L_{max} - L_{min} \leq 0.5 \text{ mm} / 0.02''$$

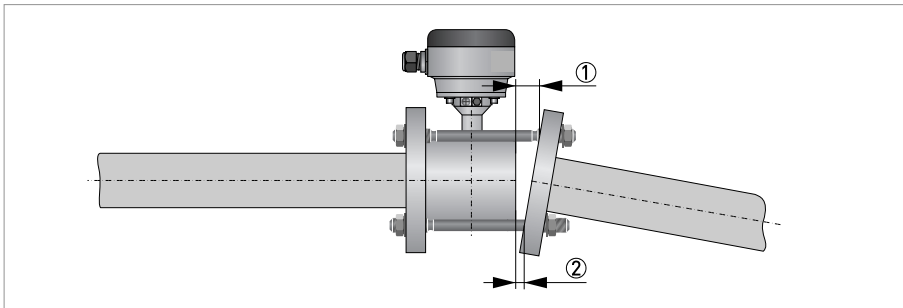

Figure 2-17: Flange deviation

- ① L_{max}
- ② L_{min}

2.8.10 Mounting position

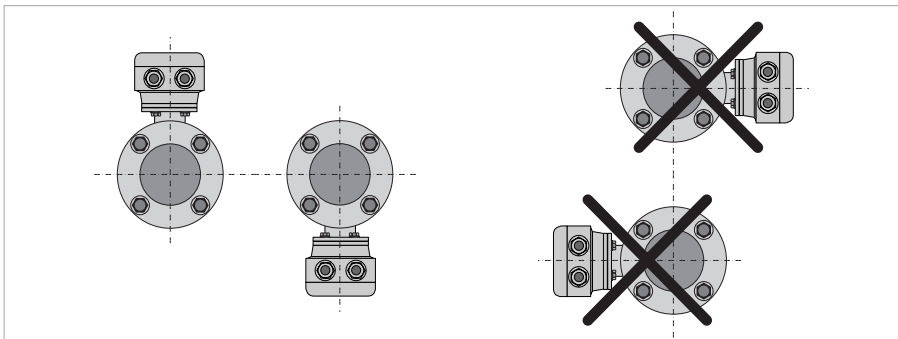

Figure 2-18: Mounting position

2.9 Mounting

2.9.1 Torques and pressures

The maximum pressure and torques values for the flowmeter are theoretical and calculated for optimum conditions and use with carbon steel flanges.

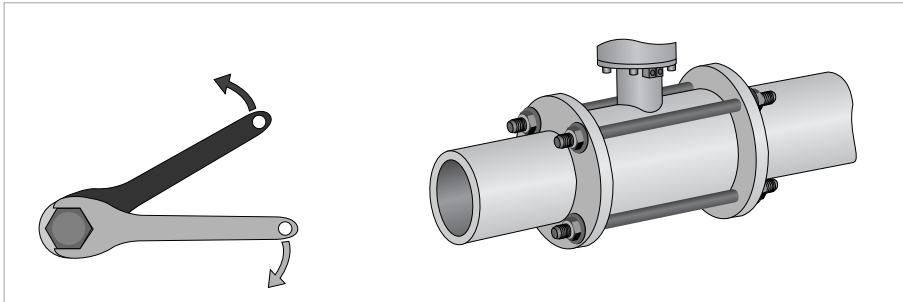

Figure 2-19: Tightening of bolts



Tightening of bolts

- Always tighten the bolts uniformly and in diagonally opposite sequence.
- Do not exceed the maximum torque value.
- Step 1: Apply approx. 50% of max. torque given in table.
- Step 2: Apply approx. 80% of max. torque given in table.
- Step 3: Apply 100% of max. torque given in table.

EN 1092-1

Nominal size DN [mm]	Counter flanges		Max. operating pressure [bar]	Bolts	Max. torque [Nm] ②
	Flange size DN [mm]	Flange class [lb]			
10	15 ①	PN 16/40	≤16	4 x M12	16
15	15	PN 16/40	≤16	4 x M12	16
25	25	PN 16/40	≤16	4 x M12	16
40	40	PN 16/40	≤16	4 x M16	25
50	50	PN 16/40	≤16	4 x M16	45
80	80	PN 16/40	≤16	4 x M16	25
100	100	PN 16	≤16	8 x M16	33
100	100	PN 40	≤16	8 x M20	33
150	150	PN 16	≤16	8 x M20	82
150	150	PN 40	≤16	8 x M24	82

① For DN10 and 15 sizes use DN15 counter (pipe) flanges.

② The specified torque values are dependent on variables (temperature, bolt material, gasket material, lubricants, etc.) which are not within the control of the manufacturer. Therefore the values should be regarded as indicative only.

ASME B16.5

Nominal size DN [inch]	Counter flanges		Max. operating pressure [psig]	Bolts	Max. torque [lbs.ft] ②
	Flange size DN [inch]	Flange class [lb]			
3/8"	1/2" ①	150/300 lb	230	4 x 1/2"	11.6
1/2"	1/2"	150/300 lb	230	4 x 1/2"	11.6
1"	1"	150/300 lb	230	4 x 1/2"	10.8
1 1/2"	1 1/2"	150/300 lb	230	4 x 1/2"	18.1
2"	2"	150/300 lb	230	4 x 5/8"	32.5
3"	3"	150 lb	230	4 x 5/8"	40.5
3"	3"	300 lb	230	8 x 5/8"	20.5
4"	4"	150/300 lb	230	8 x 5/8"	26
6"	6"	150 lb	230	8 x 3/4"	72.3
6"	6"	300 lb	230	12 x 3/4"	47.7

① For DN3/8" and 1/2" use DN1/2" counter (pipe) flanges.

② The specified torque values are dependent on variables (temperature, bolt material, gasket material, lubricants, etc.) which are not within the control of the manufacturer. Therefore the values should be regarded as indicative only.

**CAUTION!**

- Pressures are applicable at 20° C / 68° F.
- For higher temperatures, the pressure ratings are as per ASME B16.5.

3.1 Safety instructions



DANGER!

All work on the electrical connections may only be carried out with the power disconnected.
Take note of the voltage data on the nameplate!



DANGER!

Observe the national regulations for electrical installations!



WARNING!

Observe without fail the local occupational health and safety regulations.
Any work done on the electrical components of the measuring device may only be carried out by properly trained specialists.



NOTICE!

Look at the device nameplate to ensure that the device is delivered according to your order.
Check for the correct supply voltage printed on the nameplate.

3.2 Grounding



DANGER!

The device must be grounded in accordance with regulations in order to protect personnel against electric shocks.

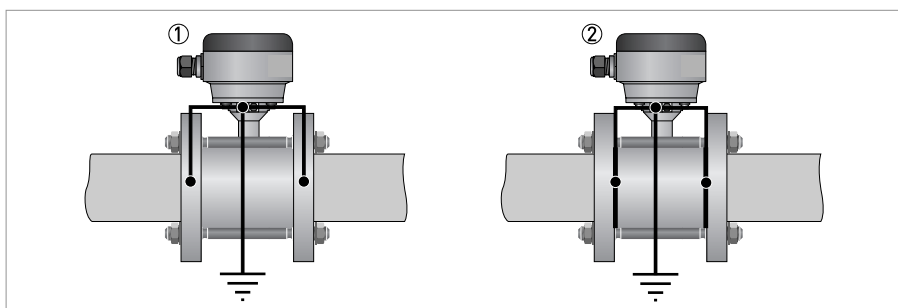

Figure 3-1: Grounding

- ① Metal pipelines, not internally coated. Grounding without grounding rings!
- ② Metal pipelines with internal coating and non-conductive pipelines. Grounding with grounding rings!

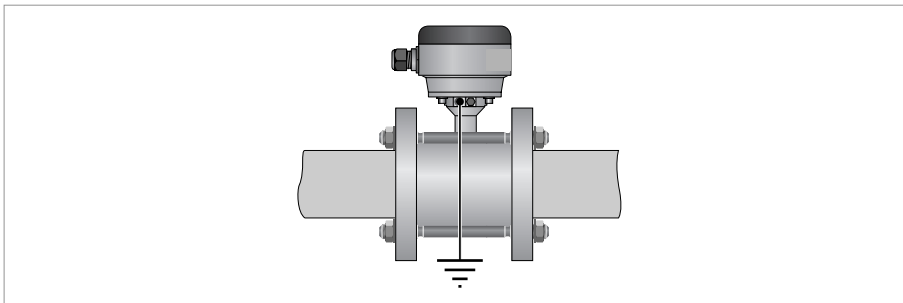

Figure 3-2: Build-in grounding rings for DN10-15 / 3/8 - 1/2 "



NOTICE!

For diameter DN10 / 3/8" and DN15 / 1/2", grounding rings are integrated as standard in the tube construction.

Grounding rings



Figure 3-3: Grounding ring number 1

Grounding ring number 1 (optional for DN25...150 / 1...6"): Thickness: 3 mm / 0.1"

3.3 Virtual reference for IMT33A (4, N and H version)

The virtual reference option on the flow converter provides complete isolation of the measurement circuit.

Benefits of virtual reference:

- Grounding rings or grounding electrodes can be omitted.
- Safety increases by reducing the number of potential leakage points.
- The installation of the flowmeters is much easier.

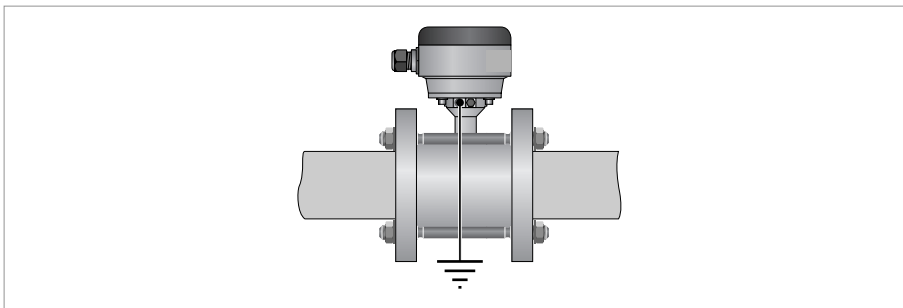

Figure 3-4: Virtual reference

Minimum requirements:

- Size: \geq DN10 / 3/8"
- Electrical conductivity: \geq 200 μ S/cm
- Electrode cable: max. 50 m / 164 ft, type DS

3.4 Connection diagrams



NOTICE!

For the connection diagrams the documentation of the applicable transmitter.

4.1 Dimensions and weights

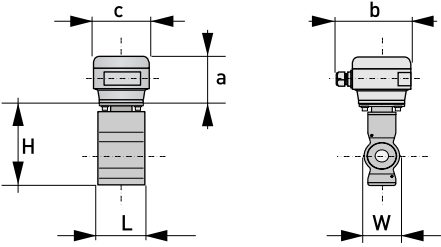
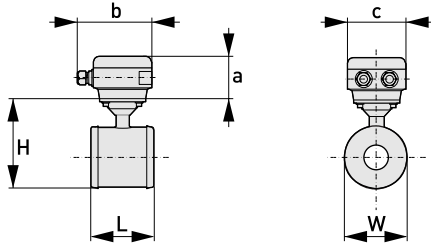
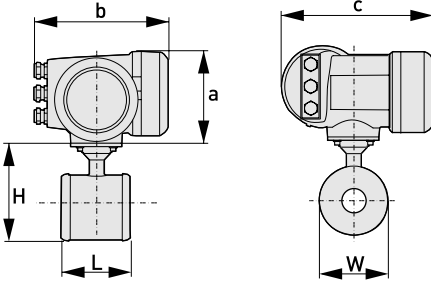
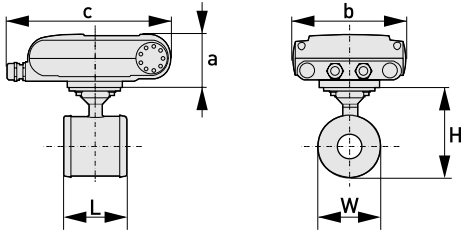
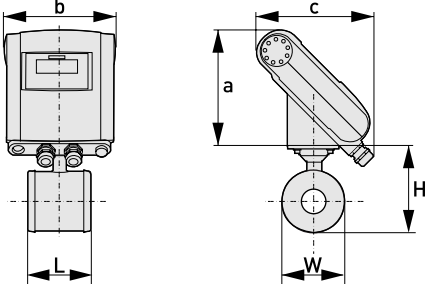
Remote version: DN10...40 / 3/8...1½"		a = 88 mm / 3.5" b = 139 mm / 5.5" ① c = 106 mm / 4.2" Total height = H + a
Remote version: DN50...150 / 2...6"		a = 88 mm / 3.5" b = 139 mm / 5.5" ① c = 106 mm / 4.2" Total height = H + a
Compact version with IMT33A		a = 155 mm / 6.1" b = 230 mm / 9.1" ① c = 260 mm / 10.2" Total height = H + a
Compact version with IMT31A (0°)		a = 82 mm / 3.2" b = 161 mm / 6.3" c = 257 mm / 10.1" ① Total height = H + a
Compact version with IMT31A (45°)		a = 186 mm / 7.3" b = 161 mm / 6.3" c = 184 mm / 7.3" ① Total height = H + a

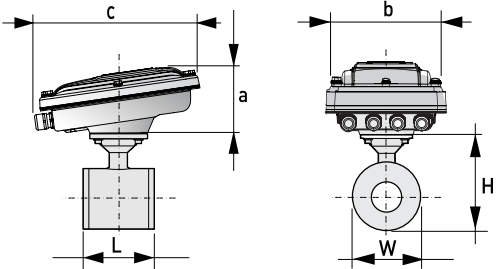
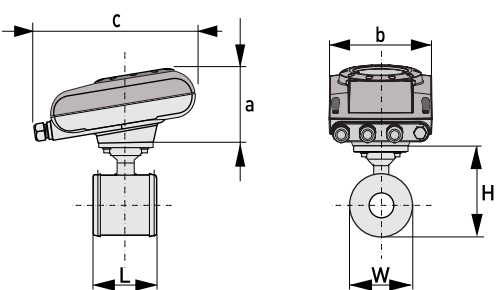
<p>Compact stainless steel version with IMT31A (10°)</p>		<p>a = 100 mm / 4" b = 187 mm / 7.36" ① c = 270 mm / 10.63" Total height = H + a</p>
<p>Compact version with IMT30A</p>		<p>a = 101 mm / 3.98" b = 157 mm / 6.18" c = 260 mm / 10.24" ① Total height = H + a</p>

① The value may vary depending on the used cable glands.

**NOTICE!**

- All data given in the following tables are based on standard versions of the flow tube only.
- Especially for smaller nominal sizes of the flow tube, the signal transmitter can be bigger than the tube.
- Note that for other pressure ratings than mentioned, the dimensions may be different.
- For full information on signal transmitter dimensions see relevant documentation.

EN 1092-1

Nominal size DN	Dimensions [mm]			Approx. weight [kg]
	L	H	W	
10	68	137	47	1.7
15	68	137	47	1.7
25	54	147	66	1.7
40	78	162	82	2.6
50	100	151	101	4.2
80	150	180	130	5.7
100	200	207	156	10.5
150	200	271	219	15.0

ASME B16.5

Nominal size ASME	Dimensions [inch]			Approx. weight [lb]
	L	H	W	
3/8"	2.68	5.39	1.85	3.7
1/2"	2.68	5.39	1.85	3.7
1"	2.13	5.79	2.6	3.7
1 1/2"	3.07	6.38	3.23	5.7
2"	3.94	5.94	3.98	9.3
3"	5.91	7.08	5.12	12.6
4"	7.87	8.15	6.14	23.1
6"	7.87	10.67	8.62	33.1





Schneider Electric Systems USA, Inc. Global Customer Support
38 Neponset Avenue Inside U.S.: 1-866-746-6477
Foxboro, MA 02035 Outside U.S.: 1-508-549-2424
United States of America <https://pasupport.schneider-electric.com>
<http://www.se.com>

Copyright 2020 Schneider Electric Systems USA, Inc.
All rights reserved.

The Schneider Electric brand and any trademarks of
Schneider Electric SE or its subsidiaries are the property
of Schneider Electric SE or its subsidiaries.
All other trademarks are the property of their respective
owners.

