

Instruction

MI 021-548 en

AUGUST 2019

**6500W + IMT65W Battery powered electromagnetic
water meter**

Quick Start

CONTENTS

1	Safety instructions	4
1.1	Instruction for transportation and handling of batteries.....	5
2	Installation	6
2.1	Scope of delivery.....	6
2.2	Device description	7
2.3	Nameplate (example)	8
2.4	Storage	9
2.5	Transport.....	9
2.6	Pre-installation requirements	9
2.7	General requirements	10
2.7.1	Vibration	10
2.7.2	Magnetic field.....	10
2.8	Installation conditions	10
2.8.1	Inlet and outlet.....	11
2.8.2	T-section	11
2.8.3	Open feed or discharge.....	11
2.8.4	Bends	12
2.8.5	Pump	12
2.8.6	Control valve	13
2.8.7	Air venting and vacuum forces	13
2.8.8	Installation in a metering pit and subsurface applications.....	14
2.8.9	Mounting position.....	16
2.8.10	Flange Deviation.....	16
2.9	Mounting.....	17
2.9.1	Torques and pressures.....	17
2.10	Mounting of the signal transmitter	20
2.10.1	Remote signal transmitter housing.....	20
2.10.2	Closing of the signal transmitter housing	21
2.10.3	Mounting of the Multi-Power unit.....	22
3	Electrical connections	23
3.1	Safety instructions.....	23
3.2	Grounding	23
3.3	Cable overview.....	24
3.4	Connection of the tube cable.....	25
3.5	Connection of the signal cable	26
3.5.1	IP68 housing (compact version).....	26
3.5.2	IP68 housing (remote version).....	27

4 Start-up	29
4.1 Types of batteries	29
4.2 Connecting the internal battery	30
4.3 Battery settings.....	31
4.4 Power supply - battery	31
4.5 Power supply - Multi-Power	32
4.5.1 Connection of the Multi-Power unit	33
5 Technical data	35
5.1 Dimensions and weights	35
6 Notes	38

1 SAFETY INSTRUCTIONS

Warnings and symbols used



DANGER!

This information refers to the immediate danger when working with electricity.



DANGER!

These warnings must be observed without fail. Even partial disregard of this warning can lead to serious health problems and even death.



WARNING!

Disregarding this safety warning, even if only in part, poses the risk of serious health problems. There is also the risk of damaging the device or parts of the operator's plant.



CAUTION!

Disregarding these instructions can result in damage to the device or to parts of the operator's plant.



NOTICE!

These instructions contain important information for the handling of the device.



HANDLING

- This symbol designates all instructions for actions to be carried out by the operator in the specified sequence.

➔ **RESULT**

This symbol refers to all important consequences of the previous actions.

Safety instructions for the operator



CAUTION!

Installation, assembly, start-up and maintenance may only be performed by appropriately trained personnel. The regional occupational health and safety directives must always be observed.



LEGAL NOTICE!

The responsibility as to the suitability and intended use of this device rests solely with the user. The supplier assumes no responsibility in the event of improper use by the customer. Improper installation and operation may lead to loss of warranty. In addition, the "Terms and Conditions of Sale" apply which form the basis of the purchase contract.



NOTICE!

Further information can be found on the website.

1.1 Instruction for transportation and handling of batteries

**WARNING!**

Lithium batteries are primary power sources with high energy content. If mistreated, they may present a potential risk.

**NOTICE!**

*The lithium batteries supplied, are **non-rechargeable**. Do NOT recharge the empty lithium batteries. Dispose of them according the local legislation in your country.*

**NOTICE!**

The manufacturer assumes no liability for customer failure.

Please observe the following instructions:

- Transport only in special packaging with special labels and transportation documents.
- Do not short-circuit, recharge, overcharge or connect with false polarity.
- Do not expose to temperature beyond the specified temperature range or incinerate the battery.
- Do not crush, puncture or open cells or disassemble battery packs.
- Do not weld or solder to the body of the battery.
- Do not expose contents of battery to water.
- Remove the battery from device before returning to the manufacturer for service or warranty reasons.
- Dispose battery packs in accordance with local regulations; where possible, recycle used batteries.

2 INSTALLATION

2.1 Scope of delivery

**NOTICE!**

Do a check of the packing list to make sure that you have all the elements given in the order.

**NOTICE!**

Inspect the packaging carefully for damages or signs of rough handling. Report damage to the carrier and to the local office of the manufacturer.

**NOTICE!**

The remote version will arrive in two cartons. One carton contains the signal transmitter and one carton contains the flow tube.

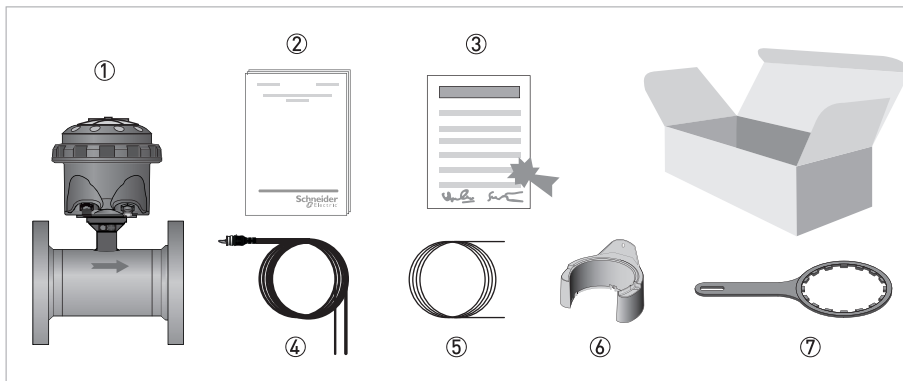

Figure 2-1: Scope of delivery

- ① Ordered water meter (compact or remote version)
- ② Product documentation
- ③ Combined signal/power cable (delivered according order)
- ④ Wall holder (remote version)
- ⑤ Special wrench for loosening the locking ring of the cover

**NOTICE!**

Assembly materials and tools are not part of the delivery. Use the assembly materials and tools in compliance with the applicable occupational health and safety directives.

**NOTICE!**

Special cable and/or cable assemblies are delivered according to the ordered signal transmitter type.

**CAUTION!**

The signal transmitter housing is delivered with attached IP67 dust caps to protect the connections of the signal transmitter. After removing the caps and connecting the signal- and tube cables, the signal transmitter housing and connections are IP68 rated.

2.2 Device description

Your measuring device is supplied ready for operation. The factory settings for the operating data have been made in accordance with your order specifications.

The following versions are available:

- Compact version (the signal transmitter is mounted directly on the measuring tube) in polycarbonate (IP68) housing
- Remote version (measuring tube with a stainless steel connection box and a signal transmitter) in a remote, polycarbonate housing

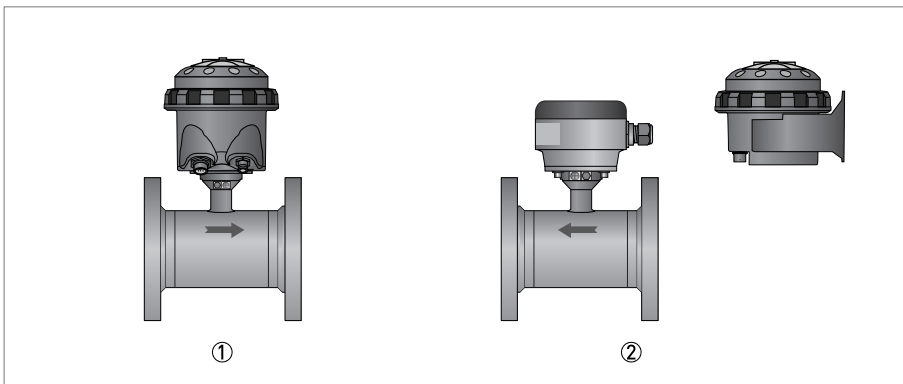

Figure 2-2: Device versions

- ① Compact version
- ② Remote version

Both versions are available with an optional integrated P&T sensor.

2 INSTALLATION

2.3 Nameplate (example)

**NOTICE!**

Check the device nameplate to ensure that the device is delivered according to your order.

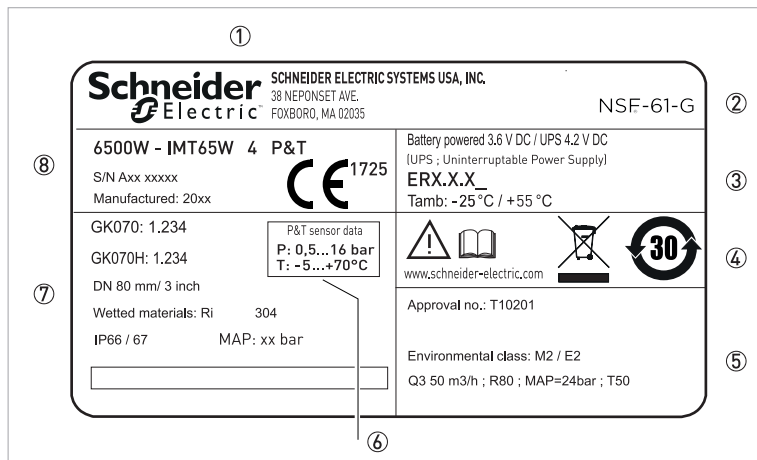

Figure 2-3: Example of nameplate

- ① Name and address of the manufacturer
- ② Additional logo and/or certifications
- ③ Battery voltage UPS and Electronic Revision number
- ④ Disposal logo and supplier website
- ⑤ Optional (MI-001): Additional information including approval number, Q3, ratio
- ⑥ Specific pressure and temperature data
- ⑦ Meter constant, diameter, wetted materials, protection class
- ⑧ Type designation of the flowmeter, serial number, date of manufacturing and CE sign with number of notified body (option: text P&T only for versions with integrated pressure and temperature sensor)

2.4 Storage

- Store the device in a dry, dust-free location.
- Avoid continuous direct sunlight.
- Store the device in its original packaging.
- Storage temperature: -30...+70°C / -22...+158°F

2.5 Transport

Signal transmitter

- No special requirements.

Compact version

- Do not lift the device by the signal transmitter housing.
- Do not use lifting chains.
- To transport flange devices, use lifting straps. Wrap these around both process connections.

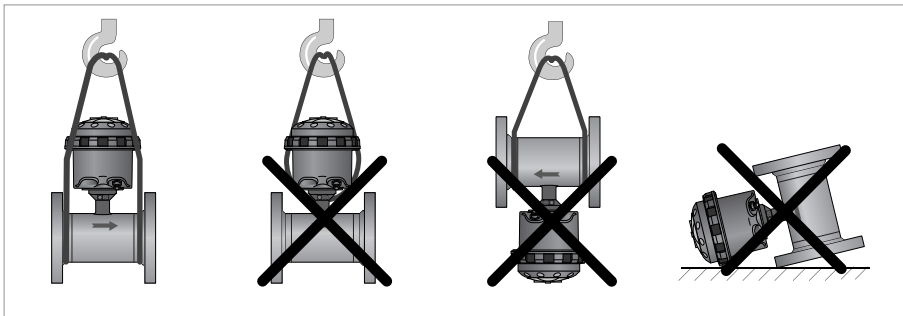

Figure 2-4: Transport

2.6 Pre-installation requirements

Make sure that you have all necessary tools available:

- Small screwdriver
- Wrench for cable glands (remote version only)
- Wrench for wall mounting bracket (remote version only)
- Torque wrench for installing flowmeter in pipeline

2 INSTALLATION

2.7 General requirements



NOTICE!

The following precautions must be taken to ensure reliable installation.

- *Make sure that there is adequate space to the sides.*
- *Protect the signal transmitter from direct sunlight and install a sun shade if necessary.*
- *Signal transmitters installed in control cabinets require adequate cooling, e.g. by fan or heat exchanger.*
- *Do not expose the signal transmitter to intense vibration. The flowmeters are tested for a vibration level in accordance with IEC 60068-2-64.*

2.7.1 Vibration

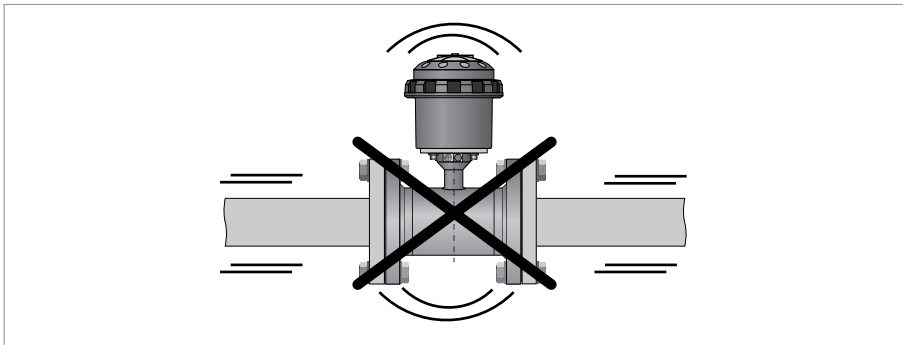

Figure 2-5: Avoid vibrations

2.7.2 Magnetic field

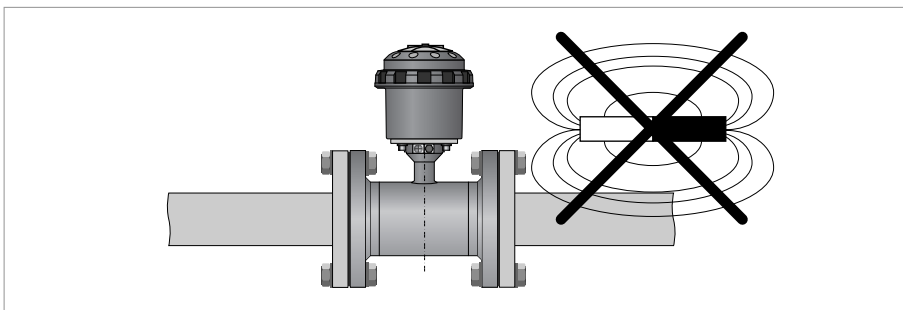

Figure 2-6: Avoid magnetic fields

2.8 Installation conditions



CAUTION!

To prevent damage to the Rilsan® coating, the 6500W tube must be installed carefully. Take precautions during transport and installation to protect the in- and outlet of the tube.

2.8.1 Inlet and outlet

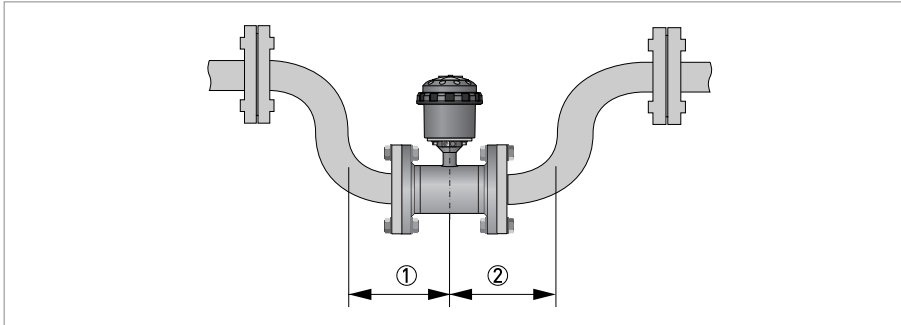

Figure 2-7: Minimal inlet and outlet

- ① Inlet: ≥ 0 DN
- ② Outlet: ≥ 0 DN

2.8.2 T-section

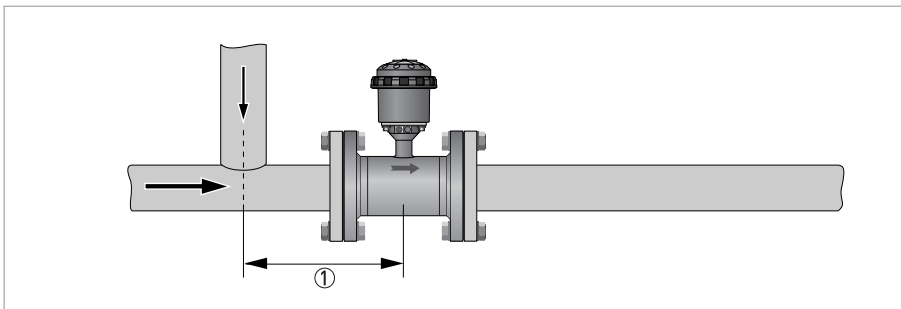

Figure 2-8: Distance behind a T-section

- ① ≥ 0 DN

2.8.3 Open feed or discharge

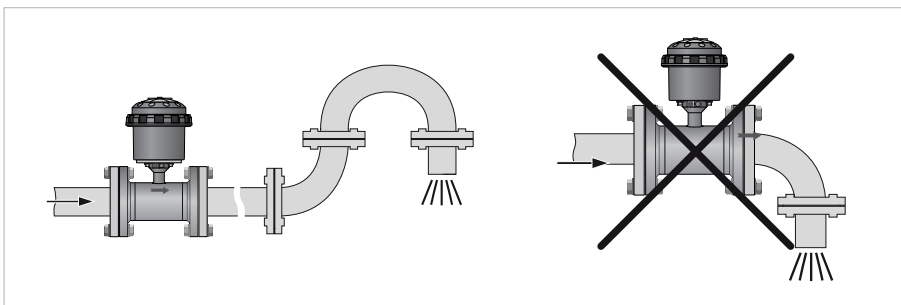

Figure 2-9: Installation in front of an open discharge

2 INSTALLATION

2.8.4 Bends

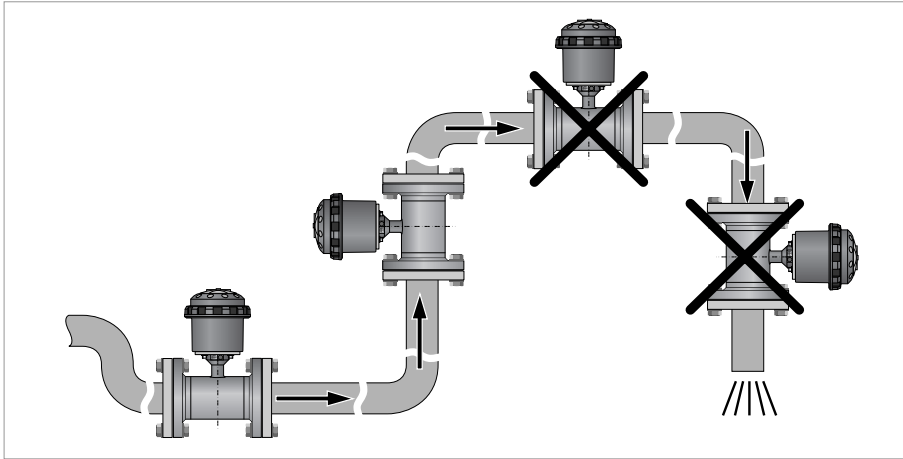

Figure 2-10: Installation in bending pipes (90°)

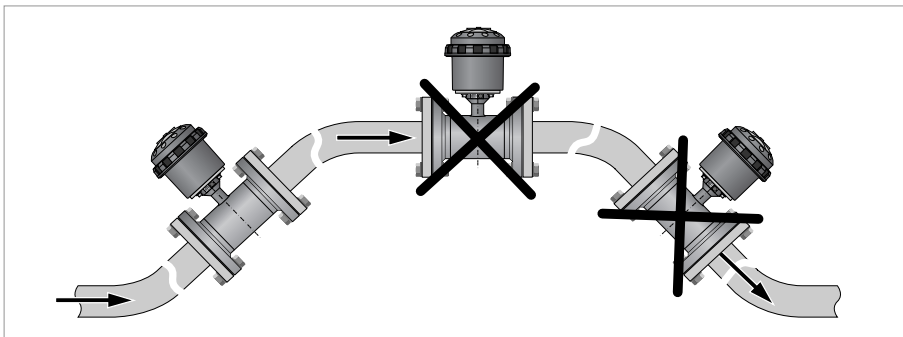

Figure 2-11: Installation in bending pipes (45°)



CAUTION!

Avoid draining or partial filling of the flow tube

2.8.5 Pump

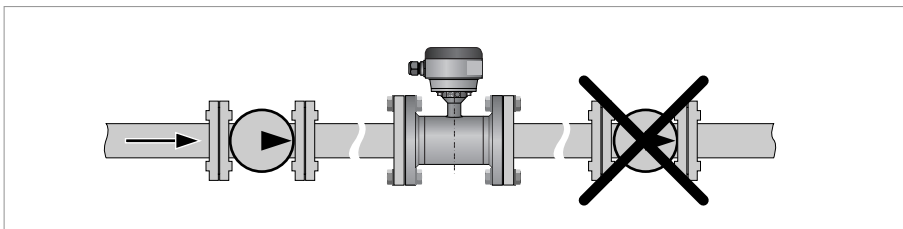

Figure 2-12: Recommended installation: behind a pump

2.8.6 Control valve

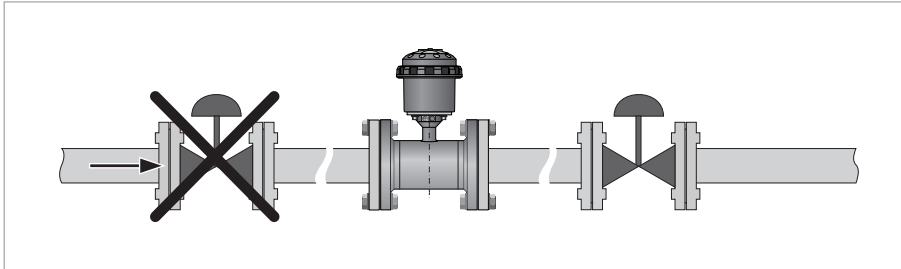

Figure 2-13: Recommended installation: in front of a control valve

2.8.7 Air venting and vacuum forces

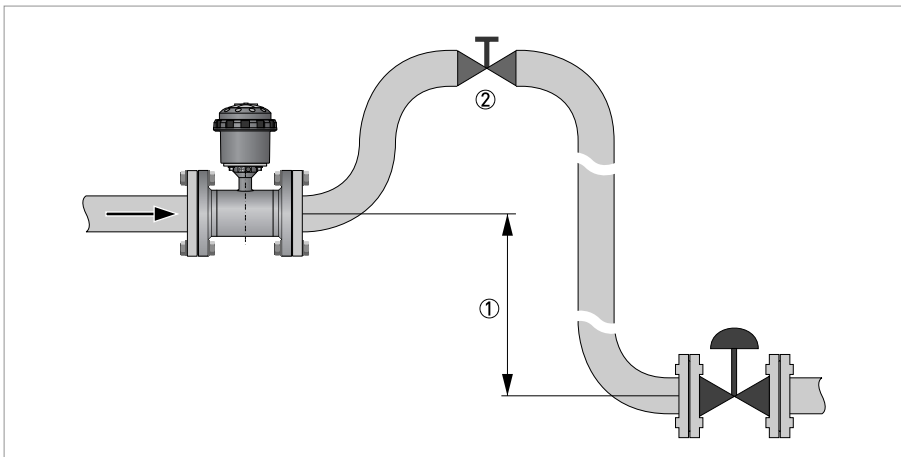
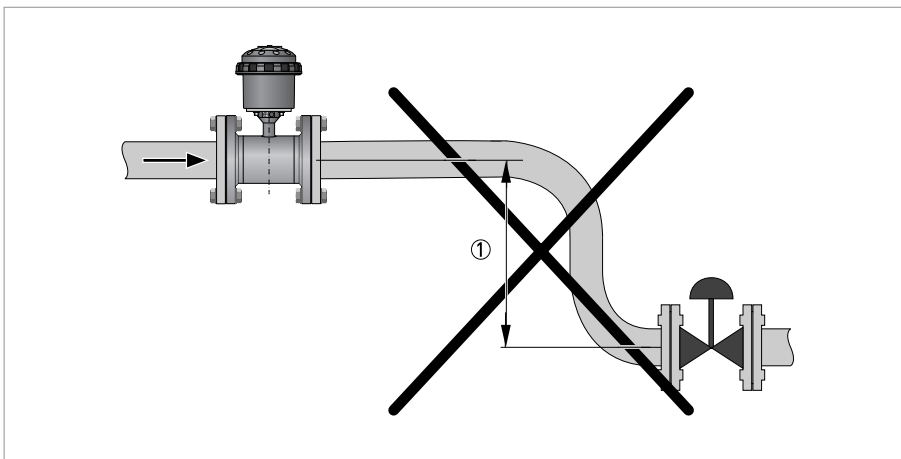

Figure 2-14: Air venting

- ① ≥ 5 m
- ② Air ventilation point



2 INSTALLATION

Figure 2-15: Vacuum

① ≥ 5 m

2.8.8 Installation in a metering pit and subsurface applications

The 6500W flow tube is IP68 rated (NEMA 4X/6P) to IEC/EN 60529. It is suitable for continuous submersion in flooded measurement chambers and can withstand a 10 meter / 33 ft water column.

The compact and remote version of the IMT65W signal transmitter is IP68 rated (NEMA 4/4X/6) and suitable for periodic submersion in flooded measurement chambers.

The signal transmitters have a polycarbonate housing and IP68 rated (military) plug and play connectors. Submersion under water is possible down to a depth of 10 meter / 33 ft. In applications with prolonged or continuous submersion, it is advised to use the 6500W + IMT65W remote version. The remote IMT65W signal transmitter and GPRS data logger unit can be installed on the wall of the measuring pit near the lid for visual read out of the display.

Submersion applications

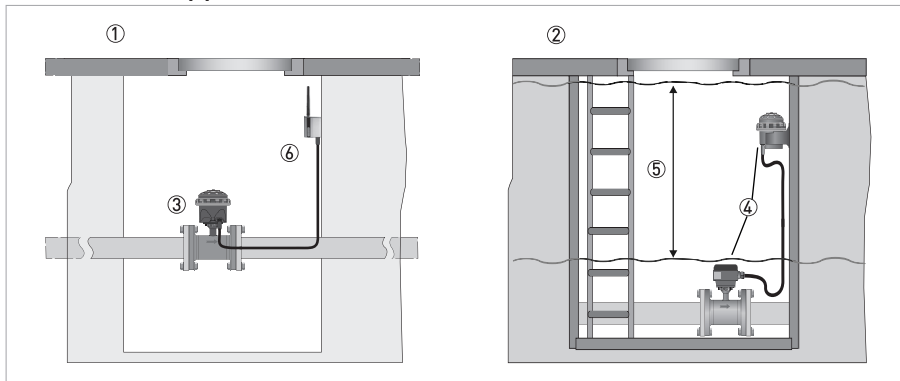

Figure 2-16: Examples of installation in measuring pit

- ① Periodic submersion
- ② Continuous submersion
- ③ Compact version
- ④ Remote version
- ⑤ Maximum water column 10 meter / 33 ft
- ⑥ GPRS / data logger unit (location)



CAUTION!

When installing flowmeter and GPRS/GSM module, follow supplier instructions.

Subsurface application

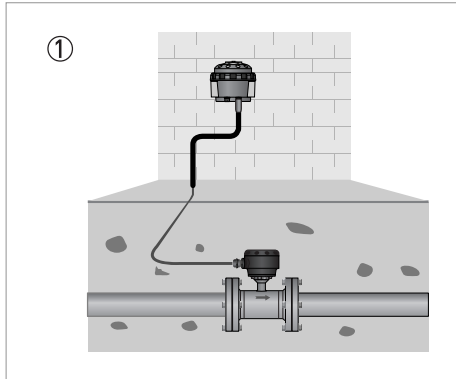

Figure 2-17: Application with buried (subsoil) tube and a field version transmitter

① 6500W + IMT65W remote version

Note: figure shows a cable ≤ 25 m / 82 ft

2 INSTALLATION

2.8.9 Mounting position

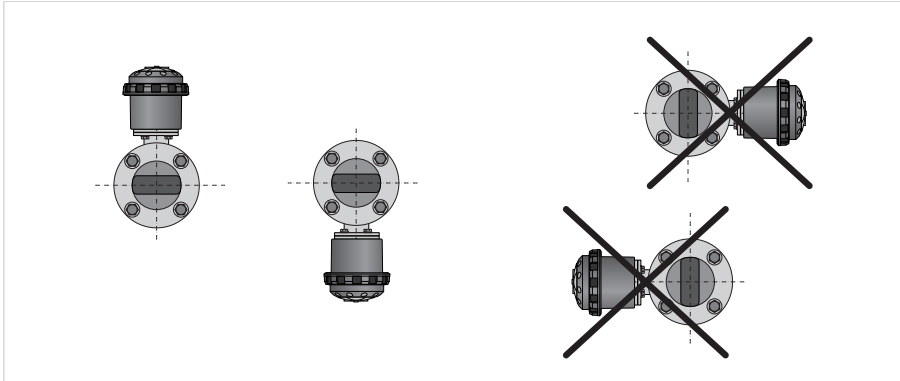

Figure 2-18: Mounting position

- Mount flow tube either with the signal transmitter aligned upwards or downwards.
- Install flow tube in line with the pipe axis.
- Pipe flange faces must be parallel to each other.

2.8.10 Flange Deviation

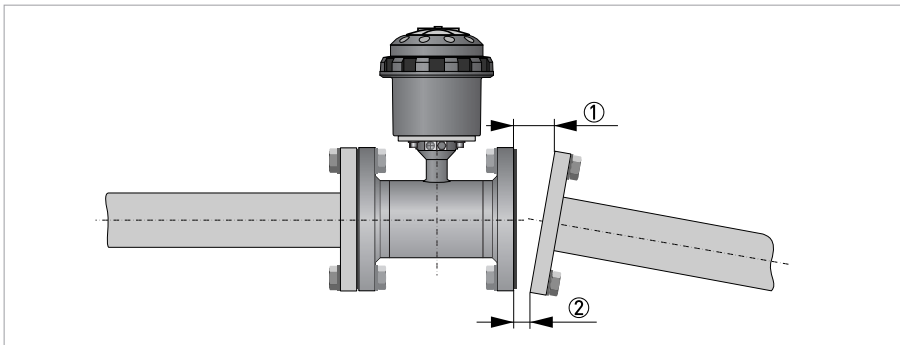

Figure 2-19: Flange deviation

- ① L_{max}
- ② L_{min}



CAUTION!

Max. permissible deviation of pipe flange faces: $L_{max} - L_{min} \leq 0.5 \text{ mm} / 0.02''$.



CAUTION!

Use the proper tools to ensure the integrity of the meter and prevent damage to the Rilsan[®] coating.

2.9 Mounting

2.9.1 Torques and pressures

The maximum pressure and torque values for the flowmeter are theoretical and calculated for optimum conditions and use with carbon steel flanges.

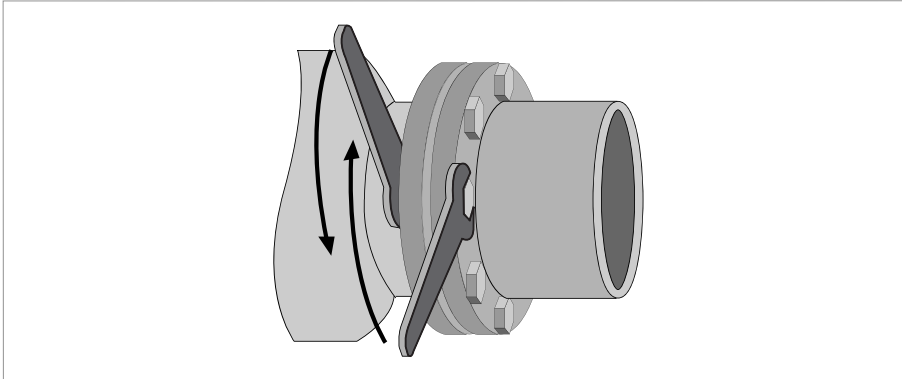

Figure 2-20: Tightening of bolts



Tightening of bolts

- Always tighten the bolts uniformly and in diagonally opposite sequence.
- Do not exceed the maximum torque value.
- Step 1: Apply approx. 50% of max. torque given in table.
- Step 2: Apply approx. 80% of max. torque given in table.
- Step 3: Apply 100% of max. torque given in table.

2 INSTALLATION

Nominal size DN [mm]	Pressure rating	Bolts	Max. torque [Nm] ^①
25	PN 16	4 x M 12	12
40	PN 16	4 x M 16	30
50	PN 16	4 x M 16	36
65	PN 16	8 x M 16	50
80	PN 16	8 x M 16	30
100	PN 16	8 x M 16	32
125	PN 16	8 x M 16	40
150	PN 10	8 x M 20	55
150	PN 16	8 x M 20	55
200	PN 10	8 x M 20	85
200	PN 16	12 x M 20	57
250	PN 10	12 x M 20	80
250	PN 16	12 x M 24	100
300	PN 10	12 x M 20	95
300	PN 16	12 x M 24	136
350	PN 10	16 x M 20	96
400	PN 10	16 x M 24	130
450	PN 10	20 x M 24	116
500	PN 10	20 x M 24	134
600	PN 10	20 x M 27	173

① The torque values also depend on variables (temperature, bolt material, gasket material, lubricants, etc.) outside the control of the manufacturer. Therefore these values should be regarded as indicative only.

Nominal size [inch]	Flange class [lb]	Bolts	Max. torque [lbs.ft] ^①
1	150	4 x 1/2"	4
1½	150	4 x 1/2"	11
2	150	4 x 5/8"	18
2.5	150	8 x 5/8"	27
3	150	4 x 5/8"	33
4	150	8 x 5/8"	22
5	150	8 x 3/4"	33
6	150	8 x 3/4"	48
8	150	8 x 3/4"	66
10	150	12 x 7/8"	74
12	150	12 x 7/8"	106
14	150 ②	12 x 1"	87
16	150 ②	16 x 1"	84
18	150 ②	16 x 1 1/8"	131
20	150 ②	20 x 1 1/8"	118
24	150 ②	20 x 1 1/4"	166

① The torque values also depend on variables (temperature, bolt material, gasket material, lubricants, etc.) outside the control of the manufacturer. Therefore these values should be regarded as indicative only.

② No full rating (max. 150 psi / 10 bar).

2 INSTALLATION

2.10 Mounting of the signal transmitter



NOTICE!

Assembly materials and tools are not part of the delivery. Use the assembly materials and tools in compliance with the applicable occupational health and safety directives.

2.10.1 Remote signal transmitter housing

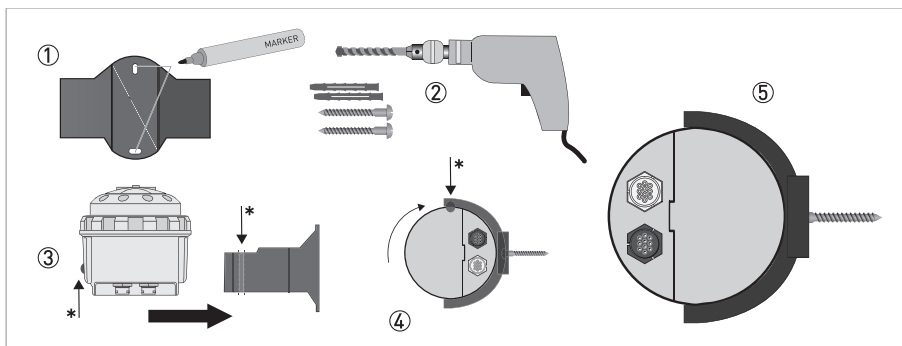

Figure 2-21: Mounting of the wall holder

- ① Mark the fixation points.
- ② Drill the holes and mount the holder with the right screws (e.g. M6 x 50 with washer) and plugs.
Do not exceed a tightening torque of 2 Nm / 1.5 lb-ft when fastening the screws. This can damage the wall holder.
- ③ Slide the IP68 remote version housing into the holder as shown.
Make sure that the positioning cam * is placed in the guiding provided for that purpose (power and data connectors positioned on the backside).
- ④ Turn the housing 180° counter clockwise (until the power and data connectors are on the front side).
Make sure that the holder snaps into the lock of the wall holder.
- ⑤ Bottom view of the IP68 remote version in to the wall holder.

2.10.2 Closing of the signal transmitter housing

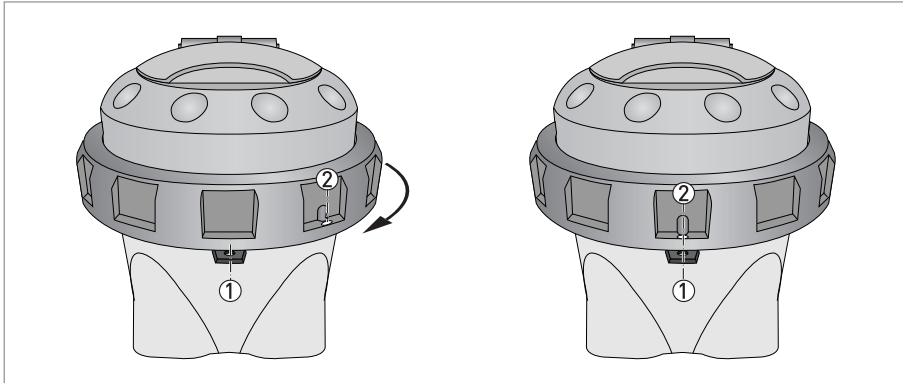

Figure 2-22: Closing of the signal transmitter housing



- Before closing the case of the signal transmitter, ensure that all surfaces in contact with the seals are clean.
- Position the upper part of the case and tighten the lock ring, up until the positions of points ① and ② are inline (do not tighten the ring any further).
- Use the special wrench to tighten the ring as advised above.
- If applicable, place a new utility seal (see section Utility Seal).

2 INSTALLATION

2.10.3 Mounting of the Multi-Power unit

The mounting of the Multi-Power unit is possible in the following options:

- Surface mounting with 2 screws on a wall or other sufficient hard surface
- On-pipe mounting with 2 Tie-Wraps

For mounting on a horizontal or vertical surface, always use the proper tools and mounting materials (e.g. drill, plug and screws). The distance between the two mounting holes is 184 mm / 7.2". Always mount the Multi-Power unit on the intended location before connecting to the tube and/or switching on the main power. When attaching the wall holder unit to the wall, do not exceed a tightening torque of 1 Nm / 0.74 lb-ft when fastening the screws. This can damage the mounting eyelets.

Mounting on the pipe line construction can easily be done by using 2 Tie-Wraps. The bottom of the housing of the Multi-Power unit is designed for mounting on a pipe line. Choose the correct size and properties of the Tie-Wraps (specifications according ambient temperature and other conditions, size, width max. 14 mm / 1/2"). Consider releasable types of Tie-Wraps when mobility and/or replacing of mounting is expected.

The Multi-Power unit is IP68 rated.



CAUTION!

Prevent water ingress to the AC or DC cable when not connected.

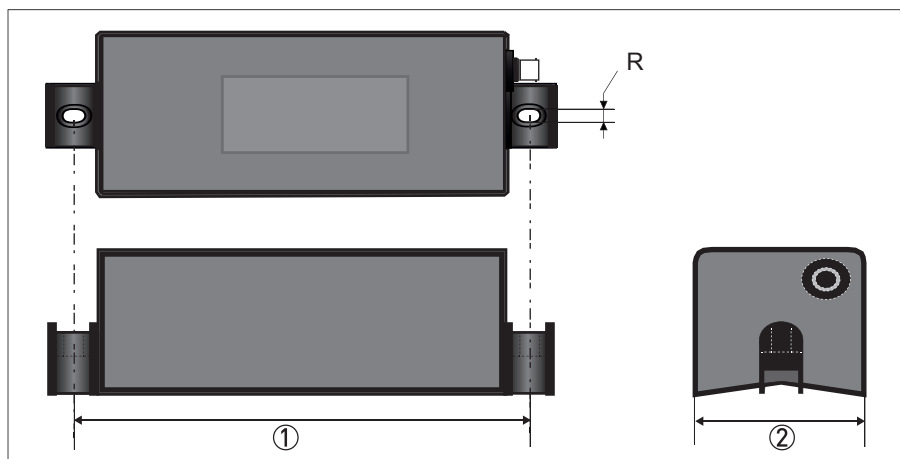

Figure 2-23: Dimensions Multi-Power

① distance = 184 mm / 7.2".

② width of unit = 74 mm / 2.9"

R = size of mounting hole ; 6 mm / 1/4"

3.1 Safety instructions



DANGER!

*All work on the electrical connections may only be carried out with the power disconnected.
Take note of the voltage data on the nameplate!*



DANGER!

Observe the national regulations for electrical installations!



WARNING!

*Observe without fail the local occupational health and safety regulations.
Any work done on the electrical components of the measuring device may only be carried out by
properly trained specialists.*



NOTICE!

*Look at the device nameplate to ensure that the device is delivered according to your order.
Check for the correct supply voltage printed on the nameplate.*

3.2 Grounding

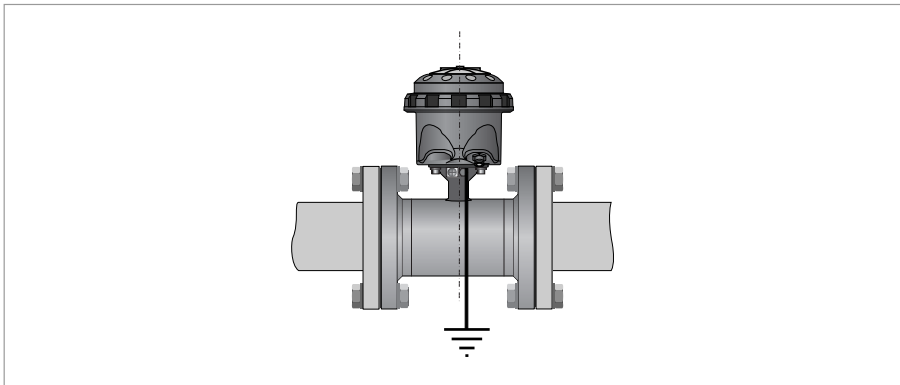

Figure 3-1: Grounding



NOTICE!

Grounding without grounding rings. The flow tube is equipped with a reference electrode.

3.3 Cable overview

The following overview describes the different cables available for the compact and remote version.

The tube cable for the IP68 remote (field) version has an 8 pin male connector.
The I/O cable (pulse /modbus) is available in a Multi-Power version and has an additional power cable connection.

Overview I/O cables, with or without a power cable, with female connector:

IP 68 Cable versions

I/O version	Multi-Power cable	PIN
Modbus cable	N	4
Pulse cable	N	8
Data logger	N	8
Modbus cable	Y	10
Pulse cable	Y	8
Data logger	Y	8

Electrical values

- **Pulse output**
2x Pulse output passive - (maximum 3 outputs possible, see status output):
 $f \leq 100 \text{ Hz}$; $I \leq 10 \text{ mA}$; $U: 2.7 \dots 24 \text{ VDC}$ ($P \leq 100 \text{ mW}$)
- **Status output**
2x Status output passive - (1 status output can be used as a third pulse output):
 $I \leq 10 \text{ mA}$; $U: 2.7 \dots 24 \text{ VDC}$ ($P \leq 100 \text{ mW}$)
- **Communication**
Modbus RTU output - (detailed information available in Supplementary Manual)

3.4 Connection of the tube cable

The compact version of the 6500W + IMT65W is already internally connected to the tube and has different options to connect pulse, Modbus and/or external supply cables. See the following sections for the different options and available cables.

For the 6500W + IMT65W remote version, a standard cable is delivered with the device. On the tube side the cable is as standard potted at the factory. The tube cable has a IP68 rated RVS snap-on connection to connect the tube with the IP68 field signal transmitter. The cables have the following colour coded leads:

Standard tube cable

Wire colour	Terminal	Function
Brown	1	Reference electrode
White	2	Standard electrode signal
Violet	3	Standard electrode signal
Blue	7	Field current
Green	8	Field current
Yellow	9	No function
Drain wires	Screws	Shielding



NOTICE!

The standard WSC2 tube cable (double shielded), includes both electrode and field current leads and has a maximum length of 25 m / 82 ft. (other lengths on request).

Tube cable with integrated P&T option

Wire colour	Contact on connector	Terminal	Function
Brown	H	1	Reference electrode / P&T sensor
White	D	4	P&T sensor
Grey	F	5	P&T sensor
Pink	B	6	P&T sensor
Blue	A	7	Field current
Green	G	8	Field current
White/White	C	2	Standard electrode signal
White/Red	E	3	Standard electrode signal
Drain wires	Housing	Screws	Shielding



CAUTION!

Make sure the device functions properly, always use the signal cables included in the delivery

3 ELECTRICAL CONNECTIONS

3.5 Connection of the signal cable

3.5.1 IP68 housing (compact version)

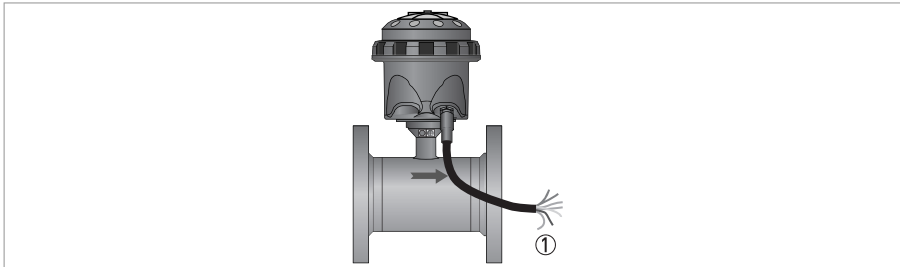

Figure 3-2: Output cable at IP68 compact version

① Color coded leads of the output cable

Pulse output cable

Wire color	Contact on connector	Function
Yellow	A	Status output 1 or threshold for P or T or pulse output C
White	G	Status output 2 or threshold for P or T
Blue	H	Ground
Brown	B	Pulse output A
Green	F	Pulse output B
Pink	C	External battery +
Grey	E	External battery -

Note; with or without shielding

Modbus cable

Note: see the next chapter for the combined power and modbus / pulse cable options.

3.5.2 IP68 housing (remote version)

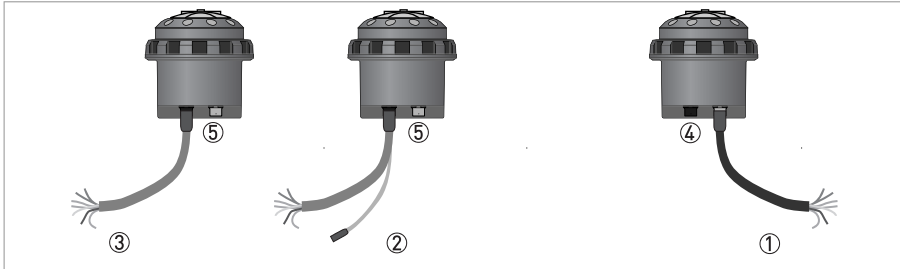

Figure 3-3: Different output cable, IP68 remote version

- ① Color coded leads of tube cable
- ② Y - cable with additional power cable
- ③ I/O cable (pulse, modbus)
- ④ I/O connection
- ⑤ RVS tube cable connection

Tube cable:

For more information; refer to *Connection of the tube cable* on page 25 for the available connection options.

For connection of I/O (modbus, pulse output signals) with or without additional power supply cable connection, several cable connection options are available. The cables have the following color code leads.

Output pulse cable

Wire color	Contact on connector	Function
Yellow	A	Status output 1 or threshold for P or T or pulse output C
White	G	Status output 2 or threshold for P or T
Blue	H	Ground
Brown	B	Pulse output A
Green	F	Pulse output B
Pink	C	External battery +
Grey	E	External battery -

3 ELECTRICAL CONNECTIONS

Combined power and pulse output cable (Y-cable)

Wire color	Contact on connector	Function
Yellow	A	Status output 1 or threshold for P or T or pulse output C
White	G	Status output 2 or threshold for P or T
Grey	H	Ground
Brown	B	Pulse output A
Green	F	Pulse output B
Brown	C	External power +3.6V
White	E	External power (Ground)
Shield	D	Shielding

Combined power and Modbus cable (Y-cable)

Wire color	Contact on connector	Function
Shield	C	Shielding
Brown	B	-
White	A	Ground
Green	E	Down link wire A←
Yellow	K	Down link wire B←
Pink	H	Up link wire A→
Grey	J	Up link wire B→
Brown	F	External power +3.6V
White	G	External power (Ground)
Shield	D	Shielding

This cable has two pairs of wires, one for uplink and one for downlink. Both are connected within the connector. When disconnecting the cable on the tube side, the two paired wires will stay connected so there is disconnection of the RS-485.

Because of this connection (switching link wire), it makes no difference where the up- and downlink are connected.

**NOTICE!**

For proper use and installation, it is recommended to follow the advised color coded wire connections in the table above. A 120 Ω line terminator is required when the 6500W + IMT65W signal transmitter is the last device in line and/or is part of the bus connection.

Specific information is described in the supplementary Modbus manual, available on the manufacturer website.

4.1 Types of batteries

Two types of batteries with different capacities are available. They can be exchanged by one of the other types

As standard the IMT65W signal transmitter is delivered with a lithium dual D cell (3.6V 38 Ah).

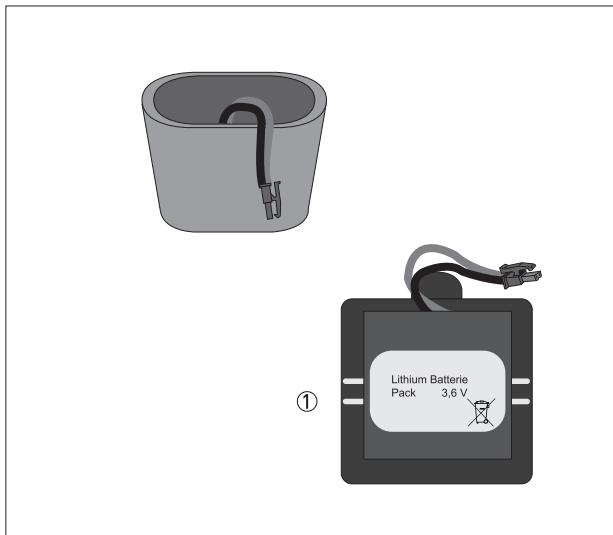

Figure 4-1: Battery and battery holder

① Internal dual D-cell battery (without / in holder ②)

4.2 Connecting the internal battery

**CAUTION!**

Please connect the battery before first use. The signal transmitter is delivered with a disconnected battery.

**NOTICE!**

For transport purposes, signal transmitters which are verified to MI-001 or OIML R49 have also disconnected batteries. Please connect battery before placing the local utility seal.

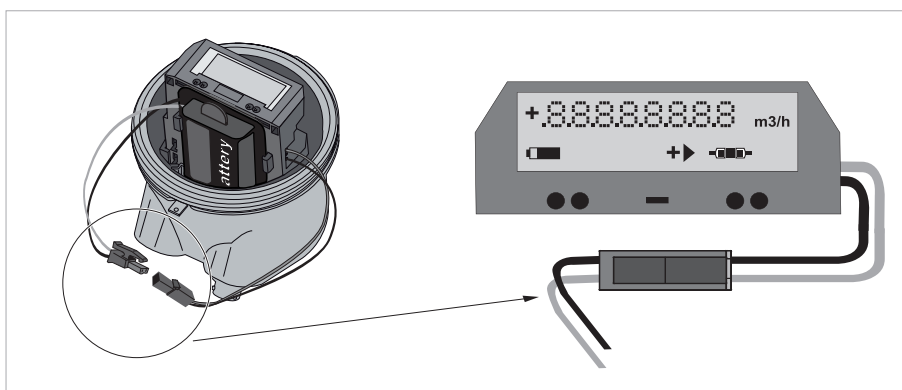

Figure 4-2: Connecting the battery



- Remove the cover.
- Fasten the battery connector of the power cable to the internal connector in the signal transmitter.
- Check if the display lights up.
- Put back the cover.

**WARNING!**

Make sure that the battery cable is not jammed by the cover.



- For closing the case of the device in the IP68 housing refer to *Closing of the signal transmitter housing* on page 21.

For information on the different battery types refer to *Types of batteries* on page 29

**NOTICE!**

The device now operates with default menu settings. refer to *Battery settings* on page 31 for configuration of these menu settings.

4.3 Battery settings

After changing the batteries:

- Reset the battery lifetime counter (Menu number B2)
- Select the battery type, if a different type of battery is used. (Menu number B0)
- Change the total battery capacity, if a different type of battery is used. (Menu number B1)

No.	Function	Options	Description
B0	Battery type	0 = No battery	A wrong setting influences the battery lifetime calculation.
		2 = Two internal batteries	
		4 = Multi-Power (2 batteries)	
B1	Total battery capacity	xxx.xx = 019.00 (19.000 Ah)	Total of all batteries in Ah. After a change to a different battery type, change the setting (19 one battery, 38 two batteries)
B2	Reset battery lifetime counter	0 = Off	Set the value to 1 to reset the battery lifetime counter. After a reset, the menu setting automatically goes back to 0.
		1 = Reset	
B3	Modbus operating in case of power supply failure	0 = Off	Default = Off
		1 = On	

4.4 Power supply - battery

The standard version of the 6500W + IMT65W has an internal battery pack with a Lithium double D cell (3.6V-38 Ah). There is no loss of totalizer data when exchanging and/or replacing the battery/power supply.

More information regarding the exchange / replacing of battery, typical lifetimes of batteries, see the manual.

4 START-UP

4.5 Power supply - Multi-Power

Beside regular battery power supplies, the 6500W + IMT65W can also be connected to an external Multi-Power unit.

The external Multi-Power unit has an internal Lithium battery pack (3.6 V -38 Ah) and can be connected with a combined power and output cable (Y-cable) for power input. The unit is delivered with a special power cable for connection to a 10...30 V DC supply (a.o. through wind- and/or solar energy supplies) and a cable for connecting to mains supply (110...230 V AC / 50 - 60 Hz)

The Multi-Power unit has two, not rechargeable internal batteries (3.6 V -38 Ah) for battery backup mode. There is no loss of totalizer data when connecting / disconnecting the Multi-Power unit.



WARNING!

Fire, explosion and severe burn hazard. Do not recharge, disassemble, or heat above 70°C / 158°F. Do NOT incinerate or expose contents to water



Figure 4-3: Multi-Power supply

Dimensions: L x W x H = 203 x 75 x 78 mm

* The information in the illustration, can deviate from the actual marking!

4.5.1 Connection of the Multi-Power unit

Optionally, beside an internal battery, the 6500W + IMT65W can be connected to an external Multi-Power unit for mains power and/or DC power operation with battery back-up.

The input power for the Multi-Power can be realized by connection to an AC/DC supply source

- AC mains supply source : 110...230 V AC - 50/60 Hz
- DC supply source : 10...30 V DC

Automatically a start-up routine is followed, when the 6500W + IMT65W with the Multi-Power is connected properly to a live AC and/or DC supply. First the DC input is checked and if present and AC/DC converter active, the power source is DC. When AC power is present and AC/DC converter active, the power source is AC/DC. If both are not available (interrupted) the internal dual D-cell battery pack (3.6V - 38 Ah) automatically takes over the power supply.

To save energy, the 6500W + IMT65W will automatically switch to the low power consuming battery backup mode and will continue to totalize volumes but temporarily stop to transfer the data.

The Multi-Power unit is IP68 rated and totally sealed and potted to prevent ingress of water. Therefore the integrated batteries cannot be changed.

Power input / output

The 3.6V **DC power output** of the Multi-Power can easily be connected with the cable assembly that is delivered with the Multi-Power unit. The UTS snap-on connector of the cable fits in only one way to the female connector on the Multi-Power unit.

As described, **the power input** of the Multi-Power can either be chosen an AC and/or DC input. To prevent water ingress and/or shock hazard, both cable ends are IP68 sealed. If possible, it is advised to connect both AC and DC inputs on the main power source.

When one of the input cables remain disconnected, make sure that this cable is correctly installed to prevent damage to the IP68 sealed end.

4 START-UP

DC power cable (green cable)

Wire color	Connection
Red	DC (+)
Blue	DC (+)
Yellow/Green	FE (functional earth)

AC power cable (grey cable)

Wire color	Connection
Black 1	AC (-)
Black 2	AC (-)
Green/Yellow	PE (protective earth)

Cable $\emptyset = 0.75 \text{ mm}^2$



DANGER!

Observe the notes as described in this section with respect to the installation and connection of the AC and/or DC supply !



CAUTION!

*Rout non connected cables back to the power distribution box. Install cables correctly even when no power is to be connected!
Take measures to prevent water ingress and shock hazard on AC and/or DC cables when not connected.*

5.1 Dimensions and weights

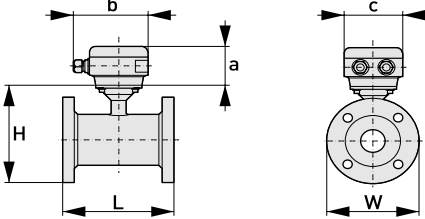
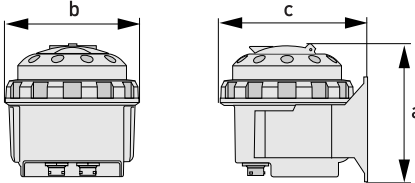
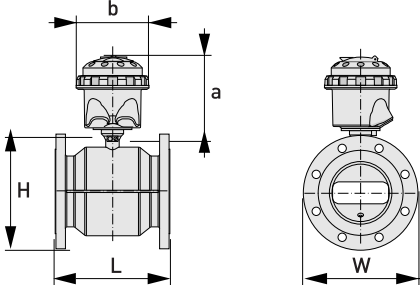
<p>Remote flow tube</p>		<p>a = 88 mm / 3.5" b = 139 mm / 5.5" ① c = 106 mm / 4.2" Total height = H + a</p>
<p>Remote signal transmitter in polycarbonate housing (IP68)</p>		<p>a = 171 mm / 6.7" b = 161 mm / 6.3" c = 177 mm / 7"</p>
<p>Compact version in polycarbonate housing (IP68)</p>		<p>a = 159 mm / 6.3" b = 161 mm / 6.3" Total height = H + a</p>

① The value may vary depending on the used cable glands.

5 TECHNICAL DATA



NOTICE!

- All data given in the following tables are based on standard versions of the flow tube only.
- Especially for smaller nominal sizes of the flow tube, the signal transmitter can be bigger than the tube.
- Note that for other pressure ratings than mentioned, the dimensions may be different.
- For full information on signal transmitter dimensions see relevant documentation.

EN 1092-1

Nominal size DN [mm]	Dimensions [mm]			Approx. weight [kg]
	L	H	W	
25	150	151	115	5
40	150	166	150	6
50	200	186	165	13
65	200	200	185	11
80	200	209	200	17
100	250	237	220	17
125	250	266	250	21
150	300	300	285	29
200	350	361	340	36
250	400	408	395	50
300	500	458	445	60
350	500	510	505	85
400	600	568	565	110
450	600	618	615	125
500	600	671	670	120
600	600	781	780	180

ASME B16.5 / 150 lb

Nominal size [inches]	Dimensions [inches]			Approx. weight [lb]
	L	H	W	
1	5.91	5.83	4.3	18
1½	5.91	6	4.9	21
2	7.87	7.05	5.9	34
3	7.87	8.03	7.5	42
4	9.84	9.49	9.0	56
5	9.84	10.55	10.0	65
6	11.81	11.69	11.0	80
8	13.78	14.25	13.5	100
10	15.75	16.3	16.0	148
12	19.7	18.8	19.0	210
14	27.6	20.7	21	290
16	31.5	22.9	23.5	370
18	31.5	24.7	25	420
20	31.5	27	27.5	500
24	31.5	31.4	32	680

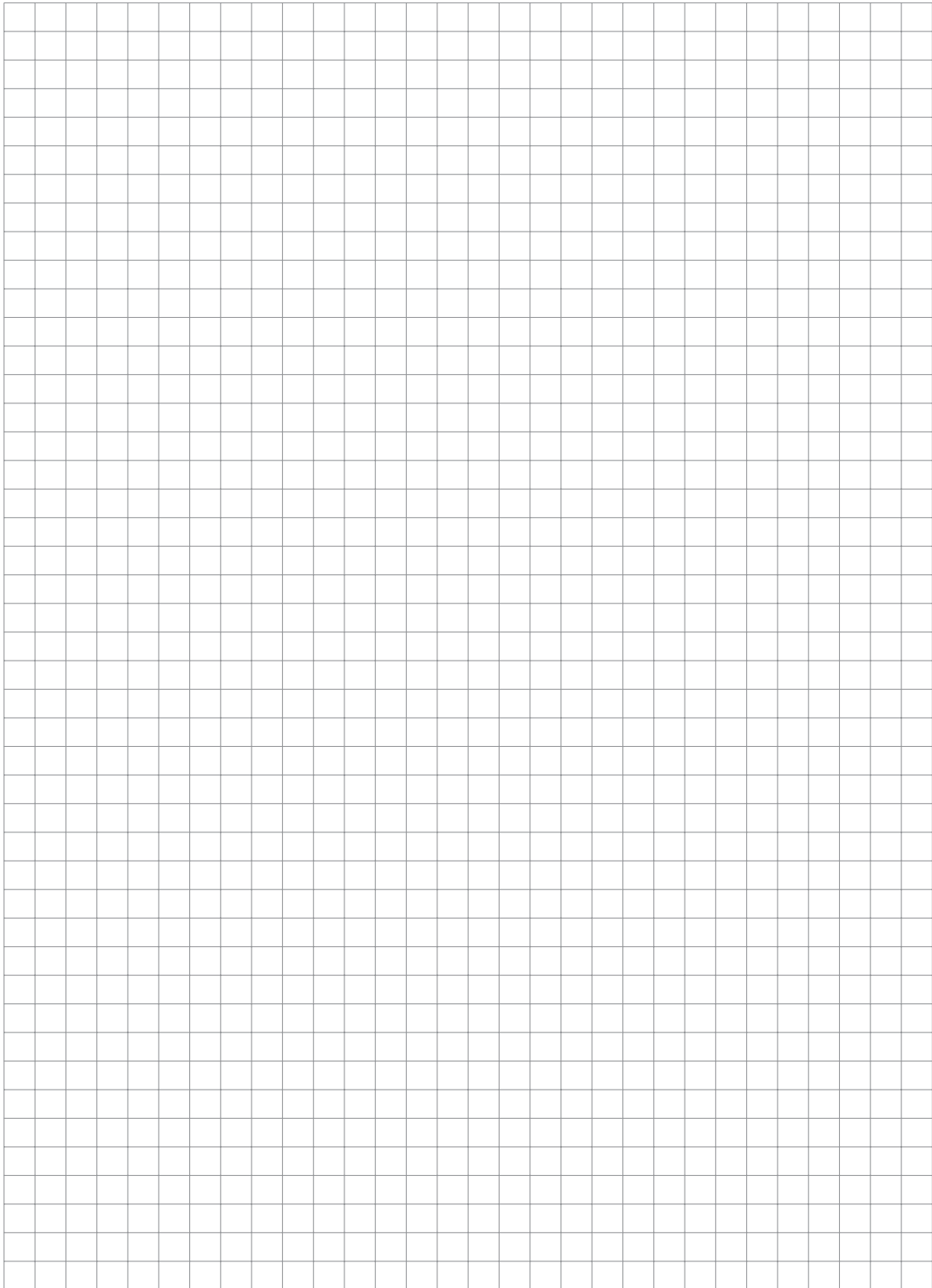

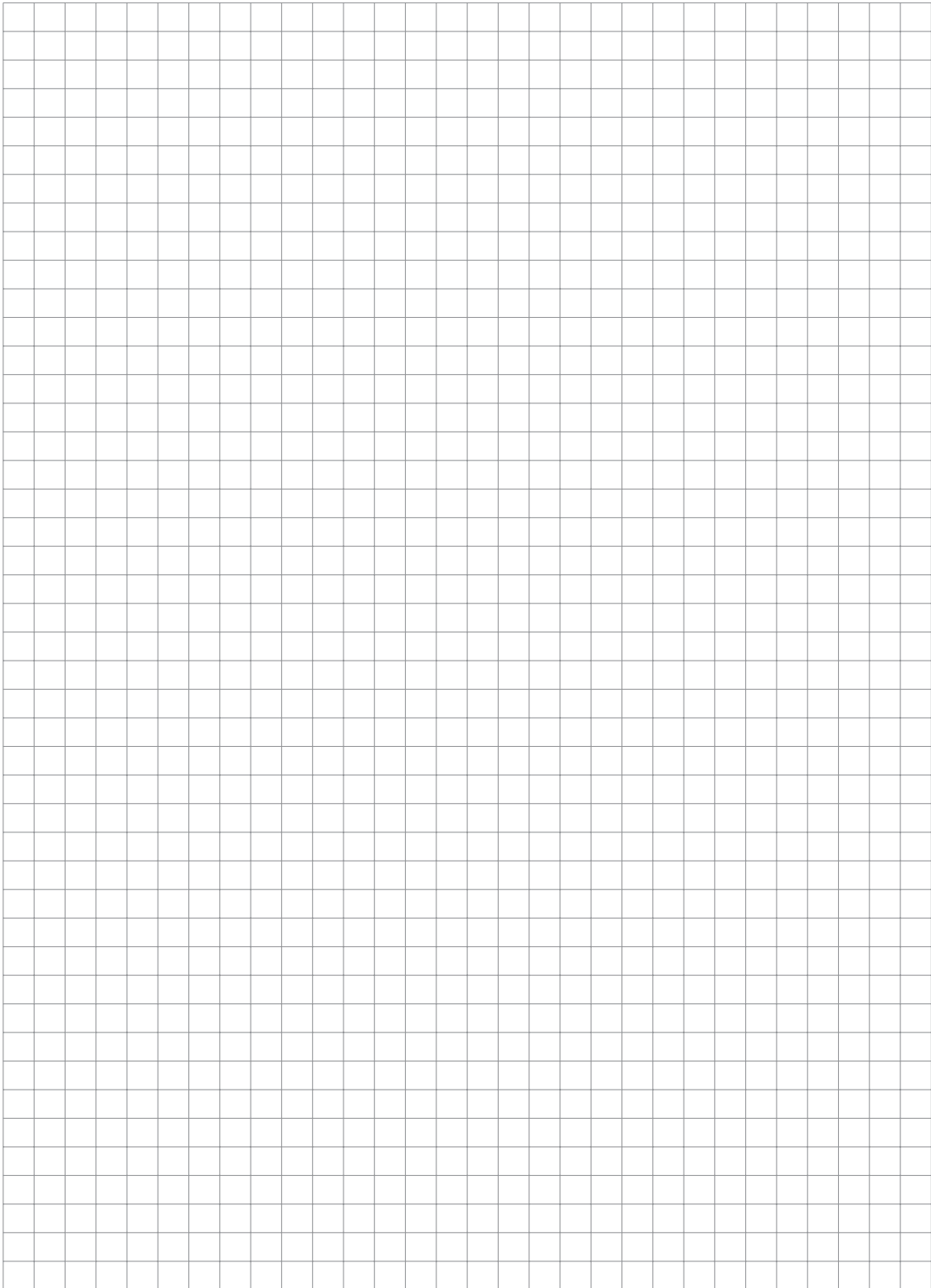

Schneider Electric Systems USA, Inc. Global Customer Support
38 Neponset Avenue Inside U.S.: 1-866-746-6477
Foxboro, MA 02035 Outside U.S.: 1-508-549-2424
United States of America <https://pasupport.schneider-electric.com>
<http://www.se.com>

Copyright 2019 Schneider Electric Systems USA, Inc.
All rights reserved.

The Schneider Electric brand and any trademarks of
Schneider Electric SE or its subsidiaries are the property
of Schneider Electric SE or its subsidiaries.
All other trademarks are the property of their respective
owners.

