

Model CFT34A Coriolis Flow Transmitter

Supplementary Instructions

Description of Modbus Interface

1	General information	5
<hr/>		
1.1	Scope of the document.....	5
1.2	Revision history	5
1.3	Abbreviations, conventions, terms and definitions.....	6
1.3.1	Terms and definitions	6
1.3.2	Abbreviations	6
1.3.3	Conventions.....	7
2	Modbus interface	8
<hr/>		
3	Modbus network	9
<hr/>		
3.1	Signals	9
3.2	Cable	9
3.3	Bus termination.....	10
3.4	Bus polarisation.....	10
3.5	Network	10
3.5.1	Grounding arrangements	10
3.5.2	Shield.....	10
3.5.3	Topologies	11
4	Interface	12
<hr/>		
4.1	Additional circuit.....	12
4.2	Communication status	13
4.3	Technical data.....	14
5	Commissioning	15
<hr/>		
5.1	Electrical connection.....	15
5.2	Setup communication.....	15
5.3	Address assignment.....	16
5.3.1	Broadcast support	16
5.4	DTM based device configuration	16
5.5	Display menu	17

6 Modbus	18
6.1 RTU frame format.....	18
6.1.1 Transmission delay.....	18
6.1.2 FastRTU.....	18
6.1.3 Response timeout.....	19
6.2 Timing and performance.....	19
6.3 Data representation.....	20
6.3.1 Data addresses.....	20
6.3.2 Data types.....	20
6.3.3 Data model.....	22
6.3.4 Data mapping.....	23
6.3.5 Endianness / byte order.....	24
6.4 Supported Function Codes.....	28
6.5 Device Identification.....	29
6.6 Modbus Serial Diagnostics.....	30
6.7 Modbus Exceptions.....	31
6.7.1 Improved Exception Handling.....	32
6.8 Custom Register Assignment.....	33
6.9 Interactions with the transmitter.....	35
7 Data list	36
7.1 Device.....	36
7.1.1 Control and status.....	36
7.1.2 Identification.....	38
7.2 Measured values and status.....	39
7.3 Auxiliary values.....	47
7.4 Totalisers.....	49
7.4.1 Status and values.....	49
7.4.2 Configuration.....	52
7.4.3 Set and control.....	54
7.5 Sensor setup and calibration.....	55
7.6 Sensor diagnostics.....	57
7.7 Configuration of units.....	57
7.8 Concentration.....	60
7.8.1 Basic settings.....	61
7.8.2 Data set 1.....	62
7.8.3 Data set 2.....	64
7.9 Configuration of NE 107 status groups.....	65
7.10 Modbus.....	67
7.10.1 Communication settings.....	67
7.10.2 Endianness / Byte order.....	68
7.10.3 Improved exception handling.....	70
7.10.4 Custom register assignment.....	71
7.10.5 Serial diagnostic counters.....	74

8 Appendix	76
<hr/>	
8.1 Modbus map	76
8.1.1 Input Registers / Holding Registers	76
8.1.2 Coils / Discrete inputs.....	84
8.2 Troubleshooting.....	84
8.2.1 No response to Modbus requests.....	84
8.2.2 Communication errors.....	85
8.2.3 Exception responses.....	86
8.2.4 "Illegal Data Address"	86
8.2.5 "Illegal Data Value"	86
8.2.6 "Server Device Failure"	87
8.2.7 Service questionnaire	87

1.1 Scope of the document

This additional instruction applies to the Modbus versions of the CFT34A with electronic revision ER 2.0.x.

It completes the documentation for the standard versions.
The information given in this instruction contains only the data relevant to the Modbus interface version.

The technical details given in the documentation for the standard versions remain unchanged unless they will be excluded or replaced by this supplementary instruction.

If you do not have these documents, please contact the nearest office or download them from the manufacturer's internet site.



NOTICE!

MODBUS® is a registered trademark of Schneider Electric USA, Inc., used under license by Modbus Organization, Inc.

1.2 Revision history

The "**Electronic revision (ER)**" is consulted to document the revision status of the electronics according to NAMUR NE 53.
This can be used to determine changes to the electronic equipment and effect on compatibility.

The "**Interface revision (IR)**" is used to track any modifications relevant for the Modbus interface (i.e. functionality and data set).

This document refers to a specific Modbus interface revision.

Interface revision	Electronic revision	Documentation
IR 3.0.x	ER 2.0.x	Master Instruction
		Supplementary Instructions Modbus Edition 12/2020

Table 1-1: Revision history

The interface revision is valid for ER 2.0.x or newer unless replaced by a new IR.

1.3 Abbreviations, conventions, terms and definitions

1.3.1 Terms and definitions

Term	Definition
Big-Endian	Formerly known as Motorola format describes the byte-order where the MSB is stored or transmitted at the lowest address and the LSB at the highest. "MSB first"
Byte	Consists of eight bits. The term octet explicitly denotes a sequence of eight bits but is not used in this document due to dependency and consistency with the Modbus specifications.
Master	The master is the only device that initiates a Modbus transaction. Only one master is connected to the bus. The master is also called client.
Coil	Modbus prime element representing a single bit.
Data item	An abstract name for parameter, measurement value etc. (Modbus Application Protocol Specification)
Transmitter	Used as a synonym for the Modbus server device for which this document is valid.
Little-Endian	Formerly known as Intel format describes the byte-order where the MSB is stored or transmitted at the highest address and the LSB at the lowest. "LSB first"
Modbus Data Map	Is a table representing all information about data items: reference number, PDU address, data size, data type, engineering unit etc.
Process Variable	Primary, secondary or calculated measurement values.
Register	Modbus prime element representing 16 bits.
RS-485	Also known as EIA/TIA-485-A.
Slave	The slave is a passive device on the bus. Multiple slaves can be connected to a bus depending on which PHY is used. The slave is also called server.

Table 1-2: Terms and definitions

1.3.2 Abbreviations

Abbreviation	Description
ADU	Application Data Unit
ASCII	American Standard Code for Information Interchange
CRA	Custom Register Assignment
CRC	Cyclical Redundancy Check
CRL	Custom Register List
CRM	Custom Register Mapping
DCS	Distributed Controls System
DTM	Device Type Manager
ER	Electronic Revision
FC	Function Code
FDT	Field Device Tool
HMI	Human Machine Interface

Abbreviation	Description
IEC	International Electrotechnical Commission
IEEE	Institute of Electrical and Electronics Engineers
IEH	Improved Exception Handling
IR	Interface Revision
LSB	Least Significant Byte
MB	Modbus
MEI	Modbus Encapsulated Interface
MSB	Most Significant Byte
PDU	Protocol Data Unit
PHY	Physical Layer
PLC	Programmable Logic Controller
RTU	Remote Terminal Unit

Table 1-3: Used abbreviations

1.3.3 Conventions

All numbers in this document are given in decimal numeral system unless otherwise stated. Numbers given in hexadecimal numeral system are labelled by a "0x" prefix and numbers given in binary numeral system are labelled by a "0b" prefix.

The decimal marker is a dot (decimal point).

Numerical ranges (from A to B) are represented with an ellipsis "...".

Examples

- 12345.67
- 0x 1234 = 4660
- 23...38



NOTICE!

Default values stated in this document may vary due to specific order requests.

Modern digital communication interfaces are composed of several different protocols and standards. The same also applies to Modbus which can appear in different forms. The ISO/OSI model is commonly used to visualise the structure of such an interface.

The transmitter provides a serial line Modbus interface. The data is being transferred using TIA/EIA-485-A, henceforth called RS-485, and Modbus RTU (Remote Terminal Unit) transmission mode. This form of Modbus can be called "Modbus RTU over RS-485" but is referred to as "Modbus" in the further course of this document.

The protocols and standards involved and their position in the ISO/OSI model are listed in the following table.

Layer		Implementation	Specification
7	Application	Modbus application protocol	Modbus application protocol specification V1.1b3
3...6		Not used	-
2	Data link	Modbus serial line protocol RTU	Modbus over serial line specification and implementation guide V1.02
1	Physical	(Modbus) RS-485	Modbus over serial line specification and implementation guide V1.02 TIA/EIA-485-A standard (RS-485)

Table 2-1: Modbus ISO/OSI model

Both Modbus specifications are available on the official website of the Modbus Organization, Inc.: www.modbus.org

The CFT34A with Modbus interface is designed to be connected as a server/slave device onto a 2-wire Modbus serial line network (bus). This configuration consists of a balanced twisted pair for bi-directional data transmission (half-duplex communication) and a third wire for signal ground.

3.1 Signals

The RS-485 specification defines two data lines for communication: A and B. For Modbus, the signal names are "D0", "D1" and "Common".

The following table shows typical names used by transceivers and adapters.

Modbus signal names	Other typical signal names				Logic level
D0	A/A'	TX-	Data-	TXD0	Negative with respect to D1 for a binary "1".
D1	B/B'	TX+	Data+	TXD1	Positive with respect to D0 for a binary "1".
Common	C/C'	Signal ground	GND	REF	-

Table 3-1: Modbus RS-485 signal names

The third wire ("Common") is used to provide higher noise immunity and data reliability. It is strongly recommended to use the "Common" even if it is not necessary for the actual data transmission.

For the actual terminal connection refer to *Electrical connection* on page 15.

3.2 Cable

The cables used to build the Modbus network should have the following characteristics:

- (braided) shield
- balanced/twisted pair (for D0 and D1) and a third wire (for the "Common")
- wire gauge of AWG 24 (0.2 mm²) or larger diameter
- appropriate characteristic impedance (> 100 Ω)

The maximum cable length depends on the network configuration (for details refer to *Topologies* on page 11) and transmission rate (baud rate). Theoretically, a cable length of up to 1200 m / 4000 ft is conceivable.

3.3 Bus termination

A bus termination or line termination is used to minimise reflections on the signal lines. The termination must be installed at both ends of the bus. It is not allowed to have any additional termination (i.e. on a derivation cable).

The Modbus interface provides an optional, integrated bus termination (resistor with 136Ω , 0.5 W) that can be enabled with a DIP switch (for details refer to *Additional circuit* on page 12).

3.4 Bus polarisation

The Modbus RTU transmission mode requires quiet periods on the network for synchronisation, respectively for detection of separate messages. During that time, both signal lines are not driven by any device on the network which makes them sensitive for electromagnetic interferences. With bus polarisation, also known as line polarisation or failsafe biasing, both signal lines are no longer floating but tapped to a known potential.

- Signal **D1** is connected to a pull-up resistor
- Signal **D0** is connected to a pull-down resistor

The bus polarisation must be implemented at only one location of the whole network.

The Modbus interface provides an optional, integrated bus polarisation (resistors with 562Ω , 0.2 W) that can be enabled with a DIP switch (for details refer to *Additional circuit* on page 12).

3.5 Network

3.5.1 Grounding arrangements

"Common" should be connected directly to protective ground, preferably at only one point for the entire bus.

3.5.2 Shield

At one end of each cable its shield should be connected to protective ground.

3.5.3 Topologies

The preferred configuration for a Modbus network is line topology with the devices connected directly to the bus cable (daisy chain). Devices may connect to the main bus cable (trunk) via short derivation cables (stubs). Stubs should be as short as possible and avoided wherever possible.

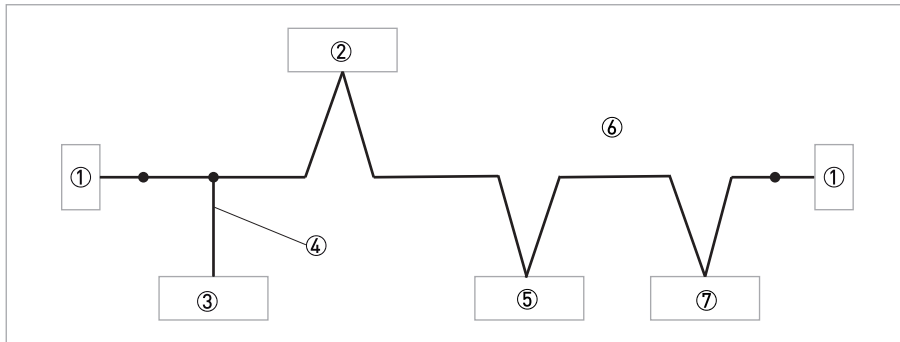

Figure 3-1: Network topology

- ① Bus termination
- ② Master
- ③ Slave 1
- ④ Stub / derivation cable
- ⑤ Slave 2
- ⑥ Bus / trunk
- ⑦ Slave N



NOTICE!

Other network topologies such as ring, star or mesh are not recommended.

4.1 Additional circuit

The Modbus interface uses a galvanic isolated RS-485 transceiver and a simple circuitry to enable or disable the bus termination and bus polarisation via DIP switches. The arrangement is shown in the following figure.

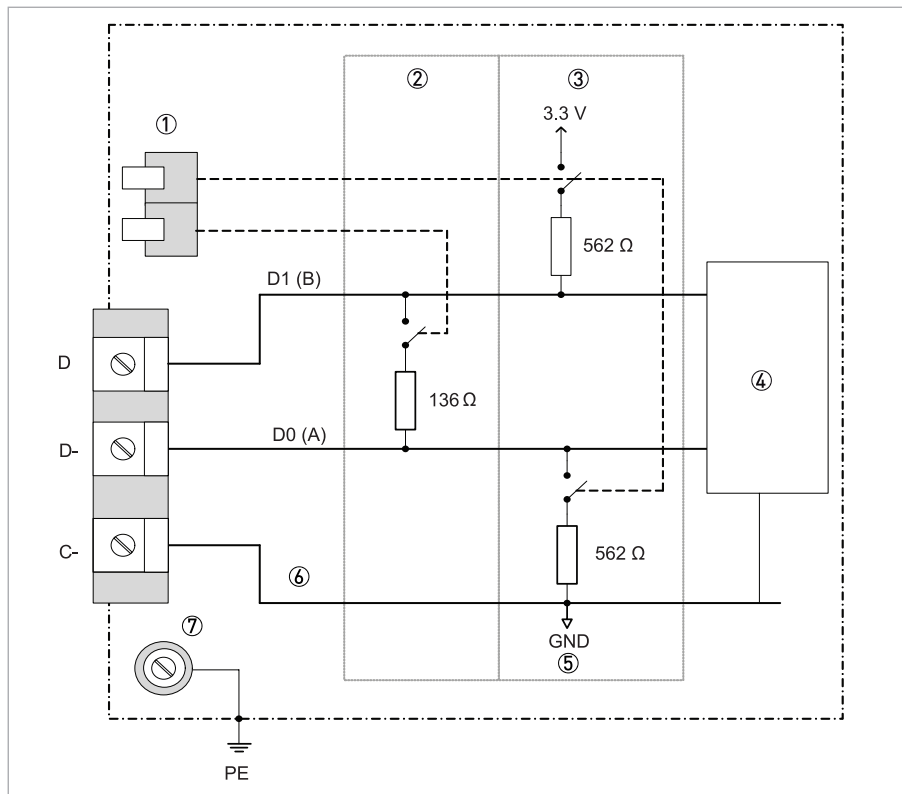

Figure 4-1: Simplified circuit diagram of the Modbus interface

- ① DIP switches
- ② Bus termination
- ③ Bus polarisation / biasing
- ④ Galvanic isolated transceiver RS-485
- ⑤ Ground
- ⑥ Common
- ⑦ Shield

4.2 Communication status

The transmitter has several LEDs that may help during commissioning and troubleshooting.

Two LEDs are mounted nearby the display and are visible with closed housing.

LED	Name	Colour	Description
S1 "MS"	Module status	Green	Modbus communication module is operational.
		Red	Modbus communication module encountered an error. Check status message page on the display.
S2 "NS"	Network status	Yellow	In the last approx. 2 seconds the transmitter has actively participated in the communication.
		Off	In the last approx. 2 seconds the transmitter has not actively participated in the communication.

Table 4-1: Status LEDs on display

Additional three LEDs are intended for expert users during troubleshooting. They are only visible with open housing and can be accessed by removing the front cover and after detaching display module.

The electronics are covered by a black plastic cap with two openings. One of the openings allows access to the DIP switch and makes the three LEDs visible, as shown in the following figure.

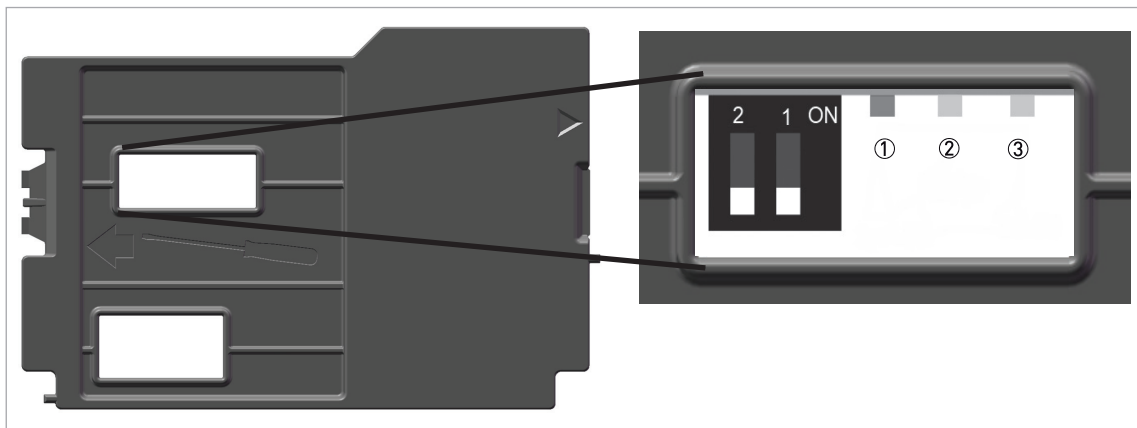

Figure 4-2: Position of DIP switch and LEDs behind the display

- ① SysLED
- ② RxLED
- ③ TxLED

Position	Function	Description
1	Bus polarisation	Enable (on) or disable (off) the integrated bus polarisation (for details refer to <i>Bus polarisation</i> on page 10). Default position is off .
2	Bus termination	Enable (on) or disable (off) the integrated bus termination (for details refer to <i>Bus termination</i> on page 10). Default position is off .

Table 4-2: DIP switch

Name	Colour	Description
SysLED ①	Pulsing heartbeat red	Normal operation
	Constant red	Fatal error, Modbus communication module is not operational.
	Flashing red at 4 Hz	Bootloader running (firmware update).
	Off	Transmitter not powered.
RxLED ②	(Flashing) yellow	Communication on the Modbus network.
	Off	No communication / transmitter not powered.
TxLED ③	(Flashing) yellow	Transmitter is sending out a Modbus message.
	Off	No communication / transmitter not powered.

Table 4-3: Diagnosis LEDs

4.3 Technical data

Baud rates	1200...115200
Receiver input tolerance (baud rate deviation)	3%
RS-485 receiver input resistance	96 k Ω = 1/8 unit load
RS-485 driver short-circuit output current	200 mA
Optionally switchable bus termination	136 Ω , 0.5 W (for details refer to <i>Bus termination</i> on page 10)
Optionally switchable bus polarisation	2 x 562 Ω , 0.2W (for details refer to <i>Bus polarisation</i> on page 10)
Galvanic isolation	> 500 VAC RMS
EMC standards	2014/30/EU
	NAMUR NE 21
	IEC 61326-2-3
	IEC 61000-6-2
	IACS 2016 / IEC 60533
DNV-GL-CG-0339	Environmental test specification for electrical, electronic and programmable equipment and systems

Table 4-4: Technical data



NOTICE!

Theoretically, the number of bus participants is 256 (8 x 32) corresponding to 1/8 unit loads, but the bus termination and polarisation reduce the possible maximum number.

5.1 Electrical connection

The transmitter is connected to the Modbus network using terminals D and D-:

Terminals	Description	
A	Terminals A and B of the transmitter are dependant on the options selected at order. Refer to the standard master instruction of the transmitter for connection details.	
A-		
A+		
B		
B-		
C	Not connected	
C-	Modbus	Common (signal ground)
D		D1 (B)
D-		D0 (A)

Table 5-1: Terminals assignment

For the description of the Modbus signals refer to *Signals* on page 9.

5.2 Setup communication

The transmitter and the Modbus master must be set to the same communication parameters.

Parameter	Default value	Legal values	Display menu
Baud rate (bps)	19200	1200, 2400, 4800, 9600, 19200, 38400, 57600, 115200	C4.2
Frame format	8E1	8E1 (8 data bits, even parity, 1 stop bit), 8O1 (8 data bits, odd parity, 1 stop bit), 8N2 (8 data bits, no parity, 2 stop bits), 8N1 (8 data bits, no parity, 1 stop bit)	C4.3

Table 5-2: Basic communication parameters



NOTICE!

All devices connected to the Modbus network must use the same baud rate and frame format!

5.3 Address assignment

The Modbus serial line protocol specifies a Modbus network with a single master and multiple slaves.

The Modbus master has no specific address while each slave must have a unique address in the range from 1 to 247; address 0 is reserved for broadcast messages. The master can use this address to send a request to all slaves connected to the network.

The transmitter is delivered with slave address 1 as default.

The slave address can be configured either via Modbus (for details refer to *Communication settings* on page 67) or the display menu C4.1.

**NOTICE!**

It is of great importance to ensure at the time of the procedure of devices addressing, that there are not two devices with the same address. In such a case, an abnormal behaviour of the whole serial bus can occur. It is then impossible for the master to communicate with all present slaves on the bus!

5.3.1 Broadcast support

**NOTICE!**

Feature for increased interoperability!

The support of broadcast messages is enabled by default but can be disabled if desired. With this option disabled, the transmitter does not process any broadcast requests.

The broadcast support can be configured either via Modbus (for details refer to *Communication settings* on page 67) or the display menu C4.6.

5.4 DTM based device configuration

A Modbus device DTM is available which allows easy and comfortable communication with the transmitter. The Modbus DTM is available for download on the manufacturer website.

The PC running the DTM acts as a Modbus master. Since Modbus allows only one master at a time, it must be ensured that other Modbus masters (i.e. a PLC) are not active:

- Disable the actual Modbus master before connecting the PC onto the network.
- Remove the transmitter from the network and establish a direct connection (point-to-point).

5.5 Display menu

The display can be used for configuration of Modbus related parameters. The entire menu structure is described in the standard master instruction in section "Function tables".

Function	Description
A Quick Setup	
A3 Configuration	
A3.1 Tag	Measuring point identifier, will be shown in the display header. Tag = Modbus UserApplicationName (for details refer to <i>Device Identification</i> on page 29).
A3.2 Slave Address	Address of the Modbus interface (for details refer to <i>Address assignment</i> on page 16).
A3.3 Baud Rate	Baud rate of the Modbus interface (for details refer to <i>Setup communication</i> on page 15).
A3.4 Frame Format	Frame format: number of data bits, number of stop bits, parity (for details refer to <i>Setup communication</i> on page 15).
A3.5 Flow Direction	Defines polarity of flow direction. Select: Forwards (according to the arrow on the flow sensor) / Backwards (in the opposite direction of the arrow)
C Setup	
C4 Modbus (RS-485)	
C4.1 Slave Address	Address of the Modbus interface (for details refer to <i>Address assignment</i> on page 16).
C4.2 Baud Rate	Baud rate of the Modbus interface (for details refer to <i>Setup communication</i> on page 15).
C4.3 Frame Format	Frame format: number of data bits, number of stop bits, parity (for details refer to <i>Setup communication</i> on page 15).
C4.4 Transmission Mode	Normal RTU transmission mode or FastRTU (for details refer to <i>FastRTU</i> on page 18).
C4.5 Transmission Delay	Additional delay before transmitter is sending out a Modbus response (for details refer to <i>Transmission delay</i> on page 18).
C4.6 Broadcast Support	Enable or disable the support of broadcast telegrams.
C4.7 Endianness of Strings	Select byte order for data type STRING.
C4.8 Endianness of 2-byte Data	Select byte order for 2-byte data types (INT, UINT, WORD).
C4.9 Endianness of 4-byte Data	Select byte order for 4-byte data types (DINT, UDINT, DWORD, REAL).
C4.10 Endianness of 8-byte Data	Select byte order for 8-byte data types (LINT, ULINT, LWORD, LREAL).
C4.11 Interface Revision	Version of the Modbus Interface (for details refer to <i>Device Identification</i> on page 29)
C4.12 Information	Serial number of the I/O board, software version number and production date of the circuit board.

Table 5-3: Display - Modbus menu structure

6.1 RTU frame format

6.1.1 Transmission delay

**NOTICE!**

Feature for enhanced versatility!

Some Modbus masters may have only a limited computing power and need some time to switch from transmission state to reception state after sending out a request message. If a Modbus slave is much faster, it may respond to that request while the master is not yet in receive mode. For this reason, a configurable transmission delay can be used to extend the time between the detection of a request and transmission of a response.

The transmission delay is 0 (disabled) by default but can be selected in the range from 0 to 50 milliseconds either via Modbus (for details refer to *Communication settings* on page 67) or the display menu C4.5.

6.1.2 FastRTU

**NOTICE!**

Feature for improved performance!

The Modbus RTU framing specifies two timing parameters that are used for message separation:

- Inter-frame delay of at least 3.5 character-times between two separate messages.
- Inter-character timeout of maximum 1.5 character-times between two consecutive characters of a message.

Both parameters depend on the baud rate, but for baud rates greater than 19200 baud, fixed values shall be used to relieve less performant devices.

- Inter-frame delay of 1.75 milliseconds.
- Inter-character timeout of 0.75 milliseconds.

This leads to long silent intervals between messages which makes high baud rates less efficient regarding the ratio of actual data transmission and idle time. The Modbus interface supports a FastRTU mode which ignores the limitation for 19200 baud and above. With FastRTU enabled, the transmitter calculates both timing parameters for all baud rates.

$$\text{character-time} = \frac{11 \text{ bit}}{\text{char}} \times \frac{1}{\text{baud rate}} = \frac{11 \text{ bit}}{\text{char}} \times \frac{1}{115200 \frac{\text{bit}}{\text{s}}} = 95,486 \frac{\mu\text{s}}{\text{char}}$$

$$\text{inter-frame delay} = t_{3,5} = 3,5 \text{ char} \times \text{character-time} = 3,5 \text{ char} \times \frac{95,486 \mu\text{s}}{\text{char}} = 334,2 \mu\text{s}$$

Figure 6-1: Equation - Bus timings at 115200 baud

Baud rate	FastRTU	Inter-character timeout	Inter-frame delay
115200	Disabled	750 μs (fixed value)	1750 μs (fixed value)
115200	Enabled	143 μs	334 μs

Table 6-1: Example of timing calculations

The transmission mode is set to normal RTU by default but can be switched to FastRTU either via Modbus (for details refer to *Communication settings* on page 67) or on the display menu C4.4.

6.1.3 Response timeout

The transmitter is implemented to respond to Modbus requests within 800 milliseconds. Normally, requests are being answered much faster. If the processing of a request exceeds 800 milliseconds, the transmitter responds with an exception "SERVER DEVICE BUSY" (for details refer to *Modbus Exceptions* on page 31).

Most Modbus masters available have a configurable parameter which defines the time how long the master waits for a response. This parameter is usually called response timeout.

The recommended response timeout is 1000 milliseconds. The Modbus master can expect to get a response from the transmitter within that time.

Since most of the requests are processed much faster, the response timeout can be decreased to a value based on response delays observed for those particular requests.

6.2 Timing and performance

This section provides information about the performance of the transmitter.

Event	Description	Duration
Power-on	Duration from power-on until the Modbus interface is available.	< 7 seconds
Apply changes	Duration required to store and apply modified parameters to internal non-volatile memory (for details refer to <i>Custom Register Assignment</i> on page 33).	< 3 seconds
Modbus response time	Typical time the transmitter needs to process a Modbus request. Depends on the requested action!	< 10 milliseconds

Table 6-2: Timings

6.3 Data representation

The following subsections describe how the data is represented on the Modbus interface.

6.3.1 Data addresses

The Modbus data addresses stated in this document are zero-based (0...65535).

Some Modbus masters ask for data numbers instead of addresses which start from one (1...65536). Such masters subtract one from the data number automatically during preparation of a request message. Please add one to all addresses stated in this document if such a Modbus master is used.

6.3.2 Data types

The Modbus interface provides data in the form of bits and bytes like any other digital communication system. A data type describes how the data is to be interpreted and processed. But the Modbus specification only distinguishes between two different types:

- Binary element: Single bit (Discrete Input or Coil)
- Register: 16-bit word (Input Register or Holding Register)

To cover the requirements of process industry, the transmitter supports additional data types according to IEC 61131-3 listed in the following table. For the description of the mapping onto the 16-bit Modbus register structure refer to *Data mapping* on page 23.

Name	Description	Size (no. of bits)	Allocated registers	Maximum range
Individual bits (bit mask operations)				
BOOL	Boolean (true/false)	1	1	{0, 1}
WORD	Bit array or bit string of 16 bits	16	1	{0, 1} ¹⁶
DWORD	Bit array or bit string 32 bits	32	2	{0, 1} ³²
LWORD	Bit array or bit string 64 bits	64	4	{0, 1} ⁶⁴
Integer / non-fractional numbers				
INT	Signed 16-bit integer	16	1	-32 768...32 767
DINT	Signed 32-bit integer	32	2	-{2 ³¹ }...{2 ³¹ }-1
LINT	Signed 64-bit integer	64	4	-{2 ⁶³ }...{2 ⁶³ }-1
UINT	Signed 16-bit integer	16	1	0...65 535
UDINT	Signed 32-bit integer	32	2	0...{2 ³² }-1
ULINT	Signed 64-bit integer	64	4	0...{2 ⁶⁴ }-1
Rational numbers				
REAL	Single-precision floating point number (IEEE 754), usually called "float"	32	2	~ ±{3.402823x10 ³⁸ }

Name	Description	Size (no. of bits)	Allocated registers	Maximum range
LREAL	Double-precision floating point number (IEEE 754), usually called "double"	64	4	$\sim \pm(1.79769 \times 10^{308})$
Characters				
STRING	Sequence of printable ASCII coded characters (7-bit US-ASCII) with no delimiter	n*8	n/2	$(32 \dots 126)^n$ ASCII code ①

Table 6-3: Supported data types

① Only printable ASCII characters are supported (0x20 to 0x7E)

Data items of type STRING have a fixed size and unused characters are filled with 0x 20 ('_', space).

6.3.3 Data model

The Modbus interface provides access to two separate memory areas (refer to following figure):

- **1-bit binary elements:**
Each element is either a Discrete Input or a Coil and allocates one bit. This area can be accessed using Modbus Function Codes for bit access (for details refer to *Supported Function Codes* on page 28).
- **16-bit registers:**
Each register is either an Input Register or a Holding Register and allocates 16 bits. This area can be accessed using Modbus Function Codes for 16-bit access (for details refer to *Supported Function Codes* on page 28).

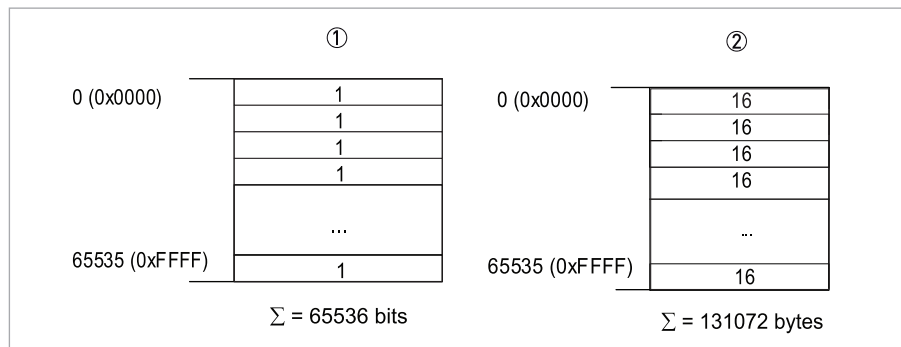

Figure 6-2: Modbus data model - Memory areas

- ① 1 bit binary elements
- ② 16 bit registers

The data model does not distinguish between Discrete Inputs or Coils as well as Input Registers or Holding Registers which makes the choice of the correct Function Code less restrictive.

Example:

The Function Codes Read Holding Registers and Read Input Registers are substitutable since they are both accessing the same memory area.

The data in those areas may have different access restrictions (e.g. a measurement value can only be read) any write operation will cause a Modbus exception SERVER DEVICE FAILURE (for details refer to *Modbus Exceptions* on page 31). Information about access restrictions are stated in the description of the data items (for details refer to *Data list* on page 36).

6.3.4 Data mapping

This section describes the mapping of data items onto the 16-bit Modbus register structure. A data item is the abstract and neutral name for parameters, measurement values, status information, etc.

The mapping of data items onto the register structure follows the most common industry standard which remains as 16-bit structure even if larger data items (i.e. 32-bit) are present.

Each data item is characterised by a data type. For the introduction of the supported data types refer to *Data types* on page 20. There is already stated how many registers are allocated for the particular data types.

There are two simple rules for accessing data items:

- Each data item allocates one or more register(s) depending on the data type.
- Data items that allocate multiple registers must be read or written completely (e.g. it is not allowed to read segments of a data item).

An overview of the entire mapping is shown in the Modbus map (for details refer to *Modbus map* on page 76).

Examples

First, two examples for **valid data item access** are considered.

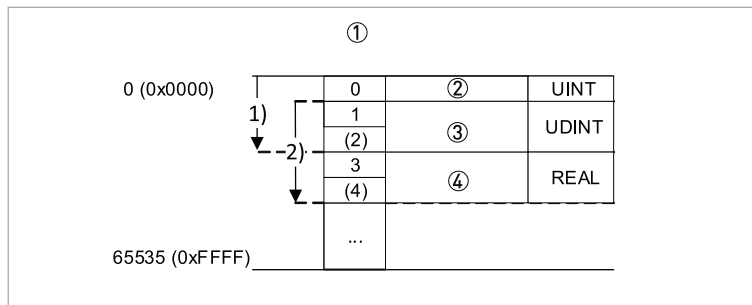

Figure 6-3: Modbus data mapping - Example (valid access)

- ① 16 bit registers
- ② Data item A
- ③ Data item B
- ④ Data item C

- Request 1) "Read data items A and B"
Start address = 0
Quantity = 3
The transmitter returns a response with the data of three registers allocated by data items A and B.
- Request 2) "Read data items B and C"
Start address = 1
Quantity = 4
The transmitter returns a response with the data of four registers allocated by data items B and C.

Furthermore, two examples for **invalid data item access** are considered.

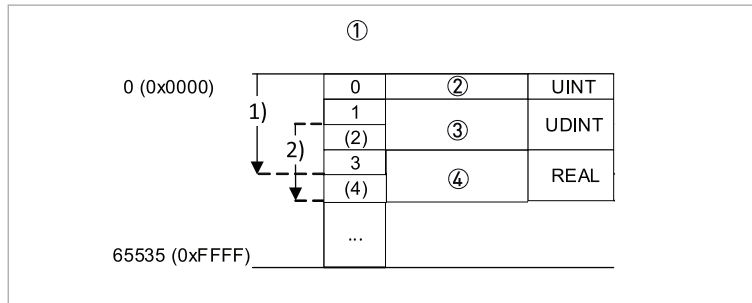

Figure 6-4: Modbus data mapping - Example (invalid access)

- ① 16 bit registers
- ② Data item A
- ③ Data item B
- ④ Data item C

- Request 1) "Read data items A, B and C incomplete"
Start address = 0
Quantity = 4
The request ends in the middle of data item C. The transmitter returns a Modbus Exception ILLEGAL DATA ADDRESS.
- Request 2) "Read Data Items B incomplete and C"
Start address = 2
Quantity = 3
The request starts in the middle of a data item. The transmitter returns a Modbus Exception ILLEGAL DATA ADDRESS.

6.3.5 Endianness / byte order

The endianness or byte order describes the sequential order in which bytes are arranged in a Modbus telegram. The Modbus Application Protocol Specification prescribes Big-Endian (Motorola) format.

The Modbus interface provides a configurable endianness for the data (payload) that is being exchanged via Modbus Function Codes in order to achieve compatibility with a wide range of Modbus masters.

The endianness of 2-byte data types, 4-byte data types, 8-byte data types and strings can be selected individually. There are data items available with constant well-known values that can be used to test for a matching endianness (for details refer to *Endianness / Byte order* on page 68).

In the following the interdependences between data types, endianness and mapping of bytes onto the Modbus register structure is described. The letters A to H are used to identify single bytes of the data items.

2-byte data types

This part describes the endianness of all 2-byte bit strings or numeric values (data types WORD, INT, UINT).

Significance		MSB	LSB
Byte Code		A	B
Example	raw data	0x 9C	0x 40
	WORD	0x 9C 40 = 0b 1001 1100 0100 0000	
	INT	- 25 536	
	UINT	40 000	

Table 6-4: Structure of a 2-byte bit string or numeric value

The following two different byte orders are specified for a 2-byte data types:

Byte no. in telegram	Register	Byte orders	
		AB	BA
0	N	A	B
1		B	A

Table 6-5: 2-byte bit string or numeric value on Modbus Registers

4-byte data types

This part describes the endianness of all 4-byte bit strings or numeric values (data types DWORD, DINT, UDINT, REAL).

Significance		MSB	LSB+2	LSB+1	LSB
Byte Code		A	B	C	D
Example	raw data	0x C7	0x F1	0x 20	0x 59
	DWORD	0x C7 F1 20 59 = 0b 1100 0111 1111 0001 0010 0000 0101 1001			
	DINT	- 940 498 855 ≈ - 940 million			
	UDINT	3 354 468 441 ≈ 3 billion			
	REAL	- 123 456.7			

Table 6-6: Structure of a 4-byte bit string or numeric value

The following four different byte orders are specified for a 4-byte data types:

Byte no. in telegram	Register	Byte orders			
		ABCD	CDAB	BADC	DCBA
0	N	A	C	B	D
1		B	D	A	C
2	N+1	C	A	D	B
3		D	B	C	A

Table 6-7: 4-byte bit string or numeric value on Modbus Registers

8-byte data types

This part describes the endianness of all 8-byte bit strings or numeric values (data types LWORD, LINT, ULINT, LREAL)

Significance		MSB	LSB+6	LSB+5	LSB+4	LSB+3	LSB+2	LSB+1	LSB
Byte Code		A	B	C	D	E	F	G	H
Example	raw data	0x C0	0x FE	0x 24	0x 0C	0x 9F	0x BE	0x 76	0x C9
	LWORD	0x C0 FE 24 0C 9F BE 76 C9 = 0b 1100 0000 1111 1110 0010 0100 0000 1100 1001 1111 1011 1110 0111 0110 1100 1001							
	LINT	- 4 540 151 737 704 614 199 ≈ - 4.5 quintillion							
	ULINT	13 906 592 336 004 937 417 ≈ 14 quintillion							
	LREAL	-123 456.789							

Table 6-8: Structure of a 8-byte bit string or numeric value

The following four different byte orders are specified for a 8-byte data types:

Byte no. in telegram	Register	Byte orders			
		ABCDEFGH	GHEFCDAB	BADCFEHG	HGFEDCBA
0	N	A	G	B	H
1		B	H	A	G
2	N+1	C	E	D	F
3		D	F	C	E
4	N+2	E	C	F	D
5		F	D	E	C
6	N+3	G	A	G	B
7		H	B	H	A

Table 6-9: 8-byte bit string or numeric value on Modbus Registers

String data types

This part describes the endianness of x-byte strings (data type STRING) where 'x' refers to the string length.

The example shows a string with an odd length filled with space.

Byte Code		A	B	C	D	E	F	G	H
Example	String	"PROFILE "							
	Character	'P'	'R'	'O'	'F'	'I'	'L'	'E'	' '
	ASCII code	0x4B	0x52	0x4F	0x48	0x4E	0x45	0x47	0x20

Table 6-10: Structure of a string

The following two different byte orders are specified for a x-byte string:

Byte no. in telegram	Register	Byte orders	
		Normal	Swapped
0	N	A	B
1		B	A
2	N+1	C	D
3		D	C
4	N+2	E	F
5		F	E
6	N+3	G	H
7		H	G

Table 6-11: x-byte string on Modbus Registers

6.4 Supported Function Codes

The transmitter supports the most common Modbus Function Codes.

Function code	Name	Description
01 (0x 01)	Read Coils	Read N binary elements
02 (0x 02)	Read Discrete Inputs	Read N binary elements
03 (0x 03)	Read Holding Register	Read N registers
04 (0x 04)	Read Input Register	Read N registers
05 (0x 05)	Write Single Coil	Write one binary element
06 (0x 06)	Write Single Register	Write one register
08 (0x 08)	Diagnostics	For details refer to <i>Modbus Serial Diagnostics</i> on page 30.
15 (0x 0F)	Write Multiple Coils	Write N binary elements
16 (0x 10)	Write Multiple Register	Write N registers

Function code	Name	Description
23 (0x 17)	Read/Write Multiple Registers	Write N registers and read N registers
43 (0x 2B)	Encapsulated Interface Transport	MEI-Type "Read Device Identification", for details refer to <i>Device Identification</i> on page 29

Table 6-12: List of supported Modbus Function Codes

6.5 Device Identification

The transmitter supports the Modbus Device Identification via:

- Function Code: "Encapsulated Interface Transport" (0x 2B)
- Modbus Encapsulated Interface (MEI) type: "Read Device Identification" (0x 0E)

The conformity level is 0x 82:

- Basic Device Identification and Regular Device Identification
- Stream access or individual access

The total size for all objects of both categories is 156 bytes.

Name	Object Id	Category	Data type	Fixed length	Content
VendorName	0x 00	Basic	STRING	24	"Schneider Electric"
ProductCode	0x 01	Basic	STRING	8	"18193"
MajorMinorRevision	0x 02	Basic	STRING	12	"IR_3.0.0" For details refer to <i>Revision history</i> on page 5.
VendorUrl	0x 03	Regular	STRING	32	"www.se.com"
ProductName	0x 04	Regular	STRING	16	"CFT34A"
ModelName	0x 05	Regular	STRING	32	Depends on the connected flow sensor.
UserApplicationName	0x 06	Regular	STRING	32	"CFT34A TAG" Can be changed via display in menu A3.1 or Modbus register access.

Table 6-13: Modbus Device Identification

The data is also available via normal Modbus register access (for details refer to *Identification* on page 38).

The "Basic" device Identification is designed to be used to test for compatibility between implementation on the Modbus master side and the devices connected:

The combination of VendorName and ProductCode identifies a specific product and the MajorMinorRevision (Interface revision, for details refer to *Revision history* on page 5) a specific version of that product.

6.6 Modbus Serial Diagnostics

The Modbus Function Code "Diagnostics" (0x08) is intended for Modbus serial devices only. The Modbus interface supports almost all sub-function codes defined by the Modbus Application Protocol Specification.

Sub-function name	Sub-function code	Description
Return Query Data	0 (0x 00 00)	Returns the data passed in the request data field. Response = Request
Restart Communication Option	1 (0x 00 01)	0x 00 00 or 0x FF 00 in the data field of the request will cause the Modbus interface to restart. The "Listen Only Mode" will be left.
Force Listen Only Mode	4 (0x 00 04)	0x 00 00 in the data field will activate the "Listen Only Mode".
Clear Counters and Diagnostic Register	10 (0x 00 0A)	Clears the diagnostic counters. Also accessible via Modbus register access (for details refer to <i>Serial diagnostic counters</i> on page 74).
Return Bus Message Count	11 (0x 00 0B)	Returns the number of messages detected on Modbus since power-on or last reset. In case of overflow, the counter proceeds with "1". Also accessible via Modbus register access for details refer to <i>Serial diagnostic counters</i> on page 74).
Return Bus Communication Error Count	12 (0x 00 0C)	Returns the number of corrupted messages (i.e. checksum error) detected on Modbus since power-on or last reset. In case of overflow, the counter proceeds with "1". Also accessible via Modbus register access for details refer to <i>Serial diagnostic counters</i> on page 74).
Return Bus Exception Error Count	13 (0x 00 0D)	Returns the number of exception responses returned by the transmitter since power-on or last reset. In case of overflow, the counter proceeds with "1". Also accessible via Modbus register access (for details refer to <i>Serial diagnostic counters</i> on page 74).
Return Server Message Count	14 (0x 00 0E)	Returns the number of messages addressed to the transmitter since power-on or last reset. In case of overflow, the counter proceeds with "1". Also accessible via Modbus register access (for details refer to <i>Serial diagnostic counters</i> on page 74).
Return Server No Response Count	15 (0x 00 0F)	Returns the number of messages detected by the transmitter for which no response was returned since power-on or last reset. In case of overflow, the counter proceeds with "1". Also accessible via Modbus register access for details refer to <i>Serial diagnostic counters</i> on page 74).
Return Server Busy Count	17 (0x 00 11)	Returns the number of messages for which the transmitter returned a BUSY exception since power-on or last reset. In case of overflow, the counter proceeds with "1". Also accessible via Modbus register access (for details refer to <i>Serial diagnostic counters</i> on page 74).
Return Bus Character Overrun Count	18 (0x 00 12)	Returns the number of messages for which the transmitter returned a NAK exception response since power-on or last reset. In case of overflow, the counter proceeds with "1". This counter is not used. Also accessible via Modbus register access (for details refer to <i>Serial diagnostic counters</i> on page 74).
Clear Overrun Counter and Flag	20 (0x 00 14)	0x 00 00 in the data field will clear the overrun error counter. Also accessible via Modbus register access (for details refer to <i>Serial diagnostic counters</i> on page 74).

Table 6-14: Modbus Serial Diagnostics sub-functions

6.7 Modbus Exceptions

The Modbus interface has six different ways to handle an invalid request:

- Communication Error: no response will be returned.
- Application Errors: exception response will be returned
 - Exception Code 01 "Illegal Function"
 - Exception Code 02 "Illegal Data Address"
 - Exception Code 03 "Illegal Data Value"
 - Exception Code 04 "Server Device Failure"
 - Exception Code 06 "Server Device Busy"

The exception codes 01, 02, 03 are used for Modbus Application Protocol specific errors only. They are not used for any error conditions during data processing. The specification of the particular Function Codes state when these exception codes shall be used. Any errors during data processing are being reported with exception codes 04 or 06.

Code	Name	Description
01	ILLEGAL FUNCTION	The requested function code is not supported.
02	ILLEGAL DATA ADDRESS	The address or quantity in the request telegram is not valid: - The requested address does not point on the start address of a data item. - The requested quantity does not comprise one or more complete data items. For details refer to <i>Data model</i> on page 22 and refer to <i>Data mapping</i> on page 23.
03	ILLEGAL DATA VALUE	An error during request telegram validation detected (i.e. specification violation).
04	SERVER DEVICE FAILURE	An error occurred during processing of the request. If the request comprises access to multiple data items, the processing is stopped on the first error. The Modbus interface checks: access rights, invalid values, etc. Detailed information on the error can be retrieved using the "Improved Exception Handling" feature (for details refer to <i>Improved Exception Handling</i> on page 32).
06	SERVER DEVICE BUSY	The transmitter was not able to process the request in time (for details refer to <i>Response timeout</i> on page 19).

Table 6-15: Modbus Exception Codes

Errors due to communications faults (CRC errors, Parity errors etc.) are logged but no response is returned because the data in the received telegram is deemed unreliable. The Modbus master system can read the error logs by using the diagnostics command (for details refer to *Modbus Serial Diagnostics* on page 30).

6.7.1 Improved Exception Handling

The "Improved Exception Handling" is an extension to the classic Modbus exception handling for providing application specific response/error codes. It is specified in a way that the classic Modbus exception handling is still entirely supported and compliant to the specification. The "Improved Exception Handling" is an optional feature that can be useful during parameterisation of the transmitter.

If the transmitter responds with the Modbus exception code 04 "Server Device Failure", three dedicated exception data items are updated with current error information. Those data items can be read right afterwards to retrieve detailed information about the previous transaction.

Address	13	14	15
Name	Error Code	Error Sub-code	Erroneous Data Item
Data	General error code (error class).	Detailed error code, depends on "Error Code".	Register start address of first erroneous data item.
Data type	UINT	UINT	UINT

Table 6-16: Structure of the "Improved Exception Handling" error registers (Data items)

The three data items are being reset (value = 0) after processing a Modbus request successfully.

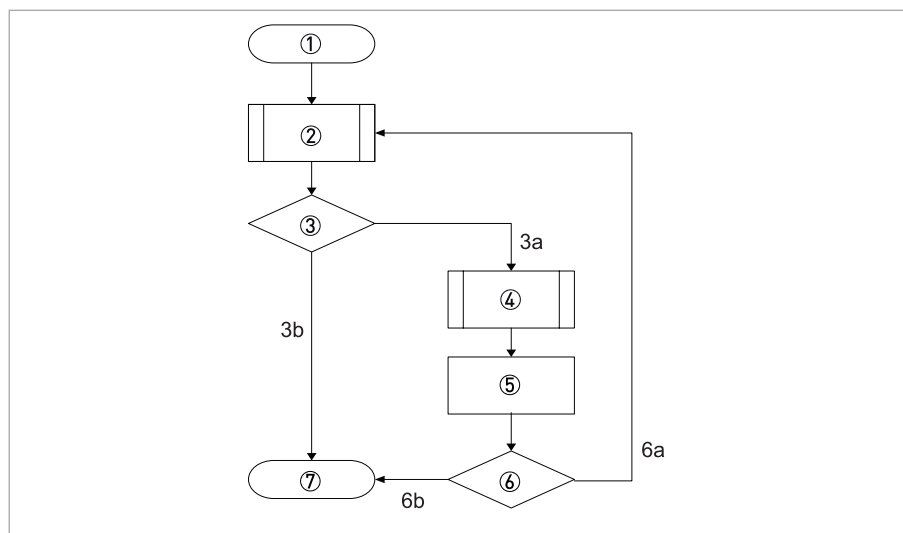

Figure 6-5: Using "Improved Exception Handling" - Modbus master perspective

- ① Start
- ② Modbus transaction
- ③ Evaluate response
 - 3a [Exception-Code 4]
 - 3b [else]
- ④ Read IEH Data Item(s)
- ⑤ Handle exception based on given information
- ⑥ Decision
 - 6a [Retry with adjusted request]
 - 6b [Abort]
- ⑦ End

6.8 Custom Register Assignment

A key feature of Modbus is the possibility to read or write contiguous registers with a single request. This works best if the data items of interest are available in such sequences of contiguous registers. The transmitter provides a huge number of different data statically mapped onto the Modbus register structure (for details refer to *Modbus map* on page 76). Not all the data is available in contiguous register sequences.

The "Custom Register Assignment", or "Custom Registers" for short, is a feature that provides a certain range of registers whose content is configurable. This range starts with register address 1000 and may reach up to register 1499 depending on the configuration. The configuration is done via 32 parameters starting at address 1500. For the description of the data items used by the "Custom Register Assignment" refer to *Custom register assignment* on page 71.

With this feature, up to 32 data items (e.g. measurement values, status information, sensor parameters, ...) can be mapped to a sequence of registers in any arbitrary choice and order. The structure of the register list results from the data types (number of allocated registers respectively) of the selected data items.

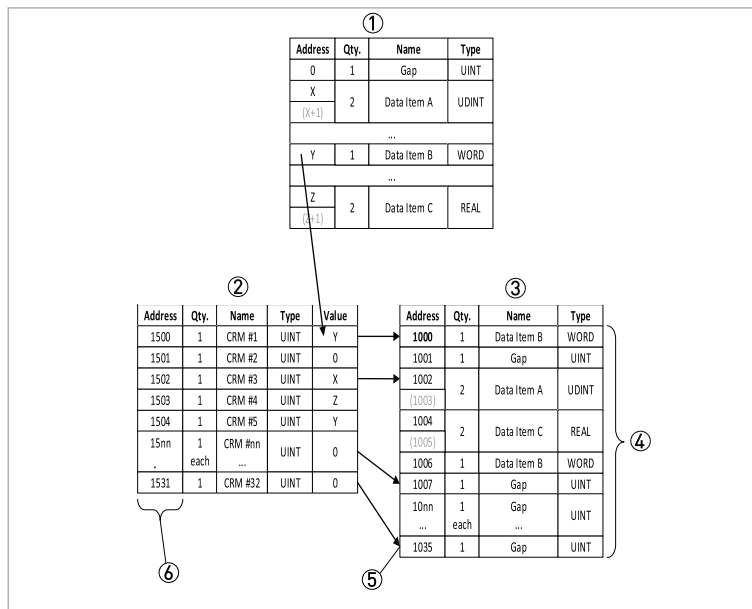

Figure 6-6: Modbus Custom Register Assignment

- ① Static Modbus Map (example)
- ② Custom Register Mapping (configuration)
- ③ Custom Register List
- ④ 32 data items total starting at address 1000
- ⑤ Reserved address space up to 1499
- ⑥ Configuration of up to 32 entries by referencing register start addresses from the static Modbus Map

The way Customer Register Assignment works is shown in the figure above as an example. The Custom Register Mapping is configured to map some data items from the static Modbus map onto the Custom Register List. Data items can be mapped multiple times (e.g. refer to Data Item B). The "Gap" data item is used as default configuration but is also intended for creating gaps in the "Custom Register List" (i.e. for alignment purpose).

Modifications of the Custom Register Mapping are being applied using the "Apply Changes" command (for details refer to *Control and status* on page 36). The final Custom Register List is internally updated then.

Erroneous configuration (i.e. invalid addresses selected or maximum address space exceeded) of the configuration is reflected via "Data Status" (for details refer to *Control and status* on page 36) and "Custom Register Mapping Status" (for details refer to *Custom register assignment* on page 71).

The Modbus DTM comes with a plugin to configure the Custom Register Assignment. It is recommended to use the DTM to setup the CRA because the GUI provides a convenient way to select the data items of interest while seeing the result at the same time.

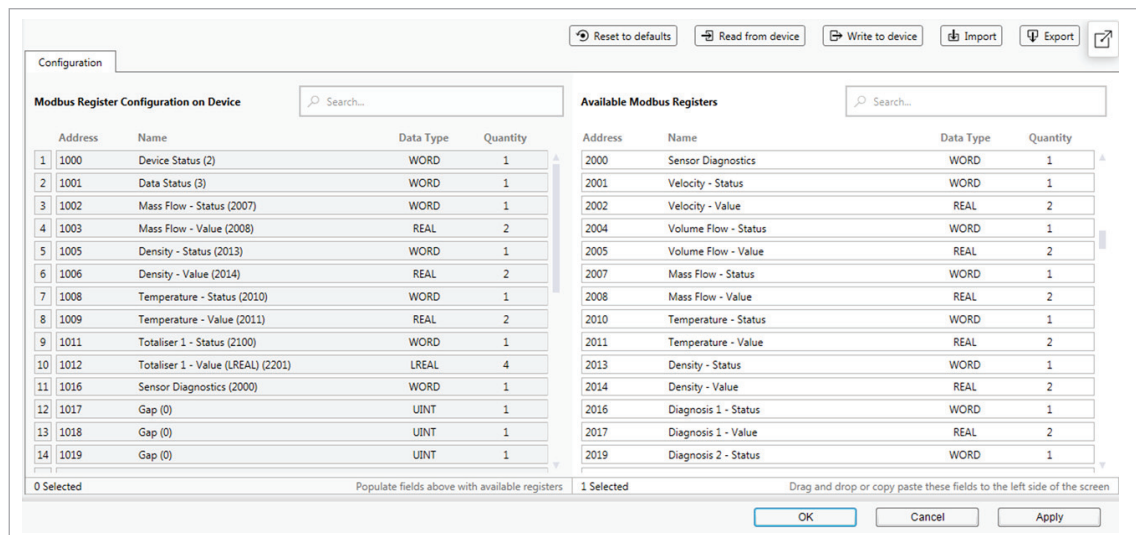

Figure 6-7: DTM Plugin for Modbus Custom Register Assignment

6.9 Interactions with the transmitter

There are three ways a Modbus master can interact with the transmitter:

- Reading data (passive, non-manipulative)
- Writing data (active, manipulative)
 - Changing configuration:
The modification of a configuration parameters is a two-stage process. If the new value was accepted, it can be read back accordingly. However, the data is not yet persistently stored or applied.
Another command must be sent in order to apply or discard such volatile data (for details refer to *Control and status* on page 36).
The "Data Status" can be evaluated in order to check if there is any volatile data pending.
 - Triggering actions:
Any actions requested will be performed immediately.

The tables in this section describe the data available on the Modbus interface. The Modbus map (for details refer to *Modbus map* on page 76) provides a complete overview of all data.

The tables contain the following columns:

- Address: Register start address of the data item
- Type: Data type of data item (for details refer to *Data types* on page 20)
- Qty: Quantity of registers allocated by the data item
- Display Fct. No.: Reference to display menu
- Fn.: Foot note

The transmitter provides many values which are related to physical quantities. If applicable, the physical quantity is stated for each data item.

Some of the data items provide its value in a fixed physical quantity. This is indicated by the term "Fix Unit". For some other data items, the unit can be configured. The description states a unit class (e.g. mass) and the value is provided in the unit selected for that unit class (e.g. mass unit = kg). For further details about units refer to *Configuration of units* on page 57.

There are data items that are not associated with a single unit class, but the unit class depends on other configuration parameters. Example: The totalisers provide values either as mass or as volume depending on the "measurement" selected (for details refer to *Configuration* on page 52).

7.1 Device

7.1.1 Control and status

This section describes the basic control of the transmitter and possibilities for monitoring the states.

It is highly recommended to monitor the "Device Status" and "Data Status".

Detailed information about the access authentication via operator password are stated in the section "Operation / Configuration management / Locking of configuration" in the standard documentation of the transmitter.

Detailed information about the "Reset to Factory" feature is described in the section "Operation / Configuration management" in the standard documentation of the transmitter.



NOTICE!

The Modbus communication parameters are also set to factory defaults!

Register Address	Type	Qty.	Name	Description	Values	Display Fct. No.	Fn.
1 (0x0001)	UINT	1	Device Control Command	Control the device by using one of the commands defined.	0 = Not used / no action (default) 1 = Apply latest changes of configuration 3 = Discard any configuration changes made since the last "Apply Changes" 4 = Resets the device to factory configuration 5 = Restart entire device	C6.3.3, A2.1, C6.2	①
2 (0x0002)	WORD	1	Device Status	Status of the device according to NE 107. (read-only)	<NE 107> Bit 0: Information (I) Bit 2: Maintenance Required (M) Bit 4: Function Check (C) Bit 5: Out of Specification (S) Bit 7: Failure (F)	-	-
3 (0x0003)	WORD	1	Data Status	Indicates status and validity of persistent data (read-only)	Bit 0: Volatile Data (changes not yet applied) Bit 1: Data Storage in progress Bit 2: Data Consistency Error Bit 3: ASL Lock Status Bit 4: Erroneous Custom Register Configuration	-	-
4 (0x0004)	UINT	1	Configuration Change Counter	Counts how often the persistent parameters have been changed via Modbus. (read-only)	Default: 0	-	-
5 (0x0005)	UDINT	2	Operating Time	Operating time of the device in seconds since production. (read-only)	Default: 0 Fix unit: [s]	B2.1	-
7 (0x0007)	UDINT	2	Uptime Counter	Device operating time since last power-on or device restart. (read-only)	Default: 0 Fix unit: [s]	-	-
4300 (0x10CC)	UINT	1	Operation Mode	Set the actual operation mode of the flow sensor.	1 = Stop Mode 3 = Measure Mode (default) 5 = Standby Mode	A8.0.0	②
8300 (0x206C)	UINT	1	Operator Password	Sets the password required to enable "access authentication". Value = 0 disables the feature.	Default: 0 Range: 0 ...9999	C6.3.4	②

Table 7-1: Modbus Data - Device - Control and status

① Not all of the commands can be executed via the display.

② Execute the "Apply Changes" command to apply and to save changes (refer to Device Control Command).

The individual actions of the Device Control Command (refer to table before) are also mapped to coils so that they can be issued using Modbus coil access.

Coil Address	Name	Description	Values	Display Fct. No.	Fn.
1000 (0x03E8)	Restart Device	Restart device. The Modbus interface is available again after a few seconds.	0 = Not used / no action (default) 1 = Perform action	-	-
1001 (0x03E9)	Reset Errors	Clears the persistent system error flags (e.g. totaliser power failure).	0 = Not used / no action (default) 1 = Perform action	A2.1, C6.2	-
1002 (0x03EA)	Apply Changes	Apply latest changes of configuration.	0 = Not used / no action (default) 1 = Perform action	-	-
1003 (0x03EB)	Discard Changes	Discard all of the configuration changes made since the last "Apply Changes" or power-on.	0 = Not used / no action (default) 1 = Perform action	-	-
1004 (0x03EC)	Factory Reset	Reset the device to factory configuration.	0 = Not used / no action (default) 1 = Perform action	C6.3.3	-

Table 7-2: Modbus data - Device - Control and status - Coils

7.1.2 Identification

The device identification can be used to check version information and to identify of the transmitter. Most of the data items are also available via Function Code 43/14 "Encapsulated Interface Transport/Read Device Identification" (for details refer to *Device Identification* on page 29).

Register Address	Type	Qty.	Name	Description	Values	Display Fct. No.	Fn.
16 (0x0010)	UINT	4	Interface Revision (array)	"Interface Revision" (IR) of the Modbus interface in array format [[Major,Minor,Revision,Suffix]] (read-only)	3,0,0,95	C4.11	-
20 (0x0014)	UINT	4	Electronic Revision (array)	"Electronic Revision" (ER) of the device in array format [[Major,Minor,Revision,Suffix]] (read-only)	2,0,4,95	B5.5	-
24 (0x0018)	STRING	6	Interface Revision (string) / MajorMinor Revision	"Interface Revision" (IR) of the Modbus interface in string format; also used as MajorMinorRevision as part of the Modbus Device Identification. (read-only)	"IR 3.0.0_"	C4.11	①

Register Address	Type	Qty.	Name	Description	Values	Display Fct. No.	Fn.
30 (0x001E)	STRING	6	Electronic Revision	Electronic Revision" (ER) of the device in string format. (read-only)	"ER 2.0.4_ "	B5.5	-
36 (0x0024)	STRING	12	VendorName	Name of the vendor. (read-only)	"Schneider Electric"	-	①
48 (0x0030)	STRING	4	ProductCode	Product number of the device. (read-only)	"xxxxxxx"	-	①
52 (0x0034)	STRING	16	VendorUrl	URL of the vendor's website. (read-only)	"www.se.com"	-	①
68 (0x0044)	STRING	8	ProductName	Product name of the device. (read-only)	"CFT34A"	-	①
76 (0x004C)	STRING	16	ModelName	Model name of the device. (read-only)	"xxxxxxxxx"	-	①
92 (0x005C)	STRING	16	Device Tag (User Application Name)	User tag, also displayed on the header of the display.	"CFT34A"		① ②

Table 7-3: Modbus data - Device - Identification

① This is a part of the Modbus Device Identification that can also be read using Function Code 43/14 Encapsulated Interface Transport/Read Device Identification.

② Execute the "Apply Changes" command to apply and to save changes (refer to "Device Control Command").

7.2 Measured values and status

The transmitter provides measured values which are described in this section. Each of the measured values has a status indicating the quality/validity. It is recommended to evaluate the status before using the associated measured value.

The preferred register section starts at address 2000 where the data is arranged in alternating order of status and value.



NOTICE!

Some of the data is mapped to more than one address.

Register Address	Type	Qty.	Name	Description	Values	Display Fct. No.	Fn.
247 (0x00F7)	REAL	2	Mass Flow - Value	Mass flow process value. (read-only)	Default: 0.0 Unit Class: Mass Flow	B2.3	-
249 (0x00F9)	REAL	2	Density - Value	Density process value. (read-only)	Default: 0.0 Unit Class: Density	B2.6	-

Register Address	Type	Qty.	Name	Description	Values	Display Fct. No.	Fn.
251 (0x00FB)	REAL	2	Temperature - Value	Temperature process value. (read-only)	Default: 0.0 Unit Class: Temperature	B2.7	-
253 (0x00FD)	REAL	2	Volume Flow - Value	Volume flow process value. (read-only)	Default: 0.0 Unit Class: Volumetric Flow	B2.4	-
2000 (0x07D0)	WORD	1	Sensor Diagnostics	Detailed sensor conditions / diagnostic information. (read-only)	Bit 0: Flow out of range Bit 1: Velocity out of range Bit 2: Process temperature out of range Bit 3: Density over range Bit 4: Electronics temperature out of specification Bit 5: Process input failure Bit 6: Sensor error Bit 7: Temperature or strain resistor defective Bit 8: Sensor signal search Bit 9: Sensor signal low Bit 10: Two phase flow over threshold Bit 11: Density calibration invalid Bit 12: Stop mode Bit 13: Standby mode Bit 14: Sensor simulation active Bit 15: System control active	-	-
2001 (0x07D1)	WORD	1	Velocity - Status	Status/validity of velocity process value. (read-only)	Bit 0: Under Range (value bounded below) Bit 1: Over Range (value bounded above) Bit 2: Maintenance Required (M) Bit 3: Initial Value (measurement inactive) Bit 4: Function Check (C) Bit 5: Out of Specification (S) Bit 7: Failure (F)	-	-
2002 (0x07D2)	REAL	2	Velocity - Value	Velocity process value. (read-only)	Default: 0.0 Unit Class: Velocity	B2.5	-
2004 (0x07D4)	WORD	1	Volume Flow - Status	Status/validity of volume flow process value. (read-only)	Bit 0: Under Range (value bounded below) Bit 1: Over Range (value bounded above) Bit 2: Maintenance Required (M) Bit 3: Initial Value (measurement inactive) Bit 4: Function Check (C) Bit 5: Out of Specification (S) Bit 7: Failure (F)	-	-
2005 (0x07D5)	REAL	2	Volume Flow - Value	Volume flow process value. (read-only)	Default: 0.0 Unit Class: Volumetric Flow	B2.4	-

Register Address	Type	Qty.	Name	Description	Values	Display Fct. No.	Fn.
2007 (0x07D7)	WORD	1	Mass Flow - Status	Status/validity of mass Flow process value. (read-only)	Bit 0: Under Range (value bounded below) Bit 1: Over Range (value bounded above) Bit 2: Maintenance Required (M) Bit 3: Initial Value (measurement inactive) Bit 4: Function Check (C) Bit 5: Out of Specification (S) Bit 7: Failure (F)	-	-
2008 (0x07D8)	REAL	2	Mass Flow - Value	Mass flow process value (read-only)	Default: 0.0 Unit Class: Mass Flow	B2.3	-
2010 (0x07DA)	WORD	1	Temperature - Status	Status/validity of temperature process value. (read-only)	Bit 0: Under Range (value bounded below) Bit 1: Over Range (value bounded above) Bit 2: Maintenance Required (M) Bit 3: Initial Value (measurement inactive) Bit 4: Function Check (C) Bit 5: Out of Specification (S) Bit 7: Failure (F)	-	-
2011 (0x07DB)	REAL	2	Temperature - Value	Temperature process value. (read-only)	Default: 0.0 Unit Class: Temperature	B2.7	-
2013 (0x07DD)	WORD	1	Density - Status	Status/validity of density process value. (read-only)	Bit 0: Under Range (value bounded below) Bit 1: Over Range (value bounded above) Bit 2: Maintenance Required (M) Bit 3: Initial Value (measurement inactive) Bit 4: Function Check (C) Bit 5: Out of Specification (S) Bit 7: Failure (F)	-	-
2014 (0x07DE)	REAL	2	Density - Value	Density process value. (read-only)	Default: 0.0 Unit Class: Density	B2.6	-
2016 (0x07E0)	WORD	1	Diagnosis 1 - Status	Status/validity of diagnosis 1 value. (read-only)	Bit 0: Under Range (value bounded below) Bit 1: Over Range (value bounded above) Bit 2: Maintenance Required (M) Bit 3: Initial Value (measurement inactive) Bit 4: Function Check (C) Bit 5: Out of Specification (S) Bit 7: Failure (F)	-	-

Register Address	Type	Qty.	Name	Description	Values	Display Fct. No.	Fn.
2017 [0x07E1]	REAL	2	Diagnosis 1 - Value	Selectable diagnosis 1 value. (read-only)	Default: 0.0 <Adj. Units> Deactivated, Tube Frequency [Hz], Strain 1 [Ohm], Strain 2 [Ohm], Drive Level [%], Two Phase Signal, Sensor Average [%], Sensor Deviation [%]	-	①
2019 [0x07E3]	WORD	1	Diagnosis 2 - Status	Status/validity of diagnosis 2 value. (read-only)	Bit 0: Under Range (value bounded below) Bit 1: Over Range (value bounded above) Bit 2: Maintenance Required (M) Bit 3: Initial Value (measurement inactive) Bit 4: Function Check (C) Bit 5: Out of Specification (S) Bit 7: Failure (F)	-	-
2020 [0x07E4]	REAL	2	Diagnosis 2 - Value	Selectable diagnosis 2 value. (read-only)	Default: 0.0 <Adj. Units> Deactivated, Tube Frequency [Hz], Strain 1 [Ohm], Strain 2 [Ohm], Drive Level [%], Two Phase Signal, Sensor Average [%], Sensor Deviation [%]	-	①
2022 [0x07E6]	WORD	1	Concentration 1 - Status	Status/validity of concentration 1 value. (read-only)	Bit 0: Under Range (value bounded below) Bit 1: Over Range (value bounded above) Bit 2: Maintenance Required (M) Bit 3: Initial Value (measurement inactive) Bit 4: Function Check (C) Bit 5: Out of Specification (S) Bit 7: Failure (F)	-	②
2023 [0x07E7]	REAL	2	Concentration 1 - Value	The proportion of the defined concentration component. (read-only)	Default: 0.0 <Adj. Units> Brix, % Mass, Baume 144, Baume 145, % NaOH, Plato, % Volume, API, % Alcohol by Mass, % Alcohol by Volume	-	②

Register Address	Type	Qty.	Name	Description	Values	Display Fct. No.	Fn.
2025 (0x07E9)	WORD	1	Concentration 2 - Status	Status/validity of concentration 2 value. (read-only)	Bit 0: Under Range (value bounded below) Bit 1: Over Range (value bounded above) Bit 2: Maintenance Required (M) Bit 3: Initial Value (measurement inactive) Bit 4: Function Check (C) Bit 5: Out of Specification (S) Bit 7: Failure (F)	-	②
2026 (0x07EA)	REAL	2	Concentration 2 - Value	The proportion of the defined concentration component. (read-only)	Default: 0.0 <Adj. Units> Brix, % Mass, Baume 144, Baume 145, % NaOH, Plato, % Volume, API, % Alcohol by Mass, % Alcohol by Volume	-	②
2028 (0x07EC)	WORD	1	Concentration 1 Flow - Status	Status/validity of concentration 1 flow value. (read-only)	Bit 0: Under Range (value bounded below) Bit 1: Over Range (value bounded above) Bit 2: Maintenance Required (M) Bit 3: Initial Value (measurement inactive) Bit 4: Function Check (C) Bit 5: Out of Specification (S) Bit 7: Failure (F)	-	②
2029 (0x07ED)	REAL	2	Concentration 1 Flow - Value	The flow rate of the defined concentration component. (read-only)	Default: 0.0 Unit class: Volumetric Flow, Mass Flow	-	②
2031 (0x07EF)	WORD	1	Concentration 2 Flow - Status	Status/validity of concentration 2 flow value. (read-only)	Bit 0: Under Range (value bounded below) Bit 1: Over Range (value bounded above) Bit 2: Maintenance Required (M) Bit 3: Initial Value (measurement inactive) Bit 4: Function Check (C) Bit 5: Out of Specification (S) Bit 7: Failure (F)	-	②
2032 (0x07F0)	REAL	2	Concentration 2 Flow - Value	The flow rate of the defined concentration component. (read-only)	Default: 0.0 Unit class: Volumetric Flow, Mass Flow	-	②
30000 (0x7530)	REAL	2	Velocity - Value	Velocity process value. (read-only)	Default: 0.0 Unit Class: Velocity	B2.5	-

Register Address	Type	Qty.	Name	Description	Values	Display Fct. No.	Fn.
30002 (0x7532)	REAL	2	Volume Flow - Value	Volume flow process value. (read-only)	Default: 0.0 Unit Class: Volumetric Flow	B2.4	-
30004 (0x7534)	REAL	2	Mass Flow - Value	Mass flow process value. (read-only)	Default: 0.0 Unit Class: Mass Flow	B2.3	-
30006 (0x7536)	REAL	2	Temperature - Value	Temperature process value. (read-only)	Default: 0.0 Unit Class: Temperature	B2.7	-
30008 (0x7538)	REAL	2	Density - Value	Density process value. (read-only)	Default: 0.0 Unit Class: Density	B2.6	-
30010 (0x753A)	REAL	2	Concentration 1 - Value	The proportion of the defined concentration component. (read-only)	Default: 0.0 <Adj. Units> Brix, % Mass, Baume 144, Baume 145, % NaOH, Plato, % Volume, API, % Alcohol by Mass, % Alcohol by Volume	-	②
30012 (0x753C)	REAL	2	Concentration 2 - Value	The proportion of the defined concentration component. (read-only)	Default: 0.0 <Adj. Units> Brix, % Mass, Baume 144, Baume 145, % NaOH, Plato, % Volume, API, % Alcohol by Mass, % Alcohol by Volume	-	②
30014 (0x753E)	REAL	2	Concentration 1 Flow - Value	The flow rate of the defined concentration component. (read-only)	Default: 0.0 Unit class: Volumetric Flow, Mass Flow	-	②
30016 (0x7540)	REAL	2	Concentration 2 Flow - Value	The flow rate of the defined concentration component. (read-only)	Default: 0.0 Unit class: Volumetric Flow, Mass Flow	-	②
30500 (0x7724)	WORD	1	Velocity - Status	Status/validity of velocity process value. (read-only)	Bit 0: Under Range (value bounded below) Bit 1: Over Range (value bounded above) Bit 2: Maintenance Required (M) Bit 3: Initial Value (measurement inactive) Bit 4: Function Check (C) Bit 5: Out of Specification (S) Bit 7: Failure (F)	-	-

Register Address	Type	Qty.	Name	Description	Values	Display Fct. No.	Fn.
30501 (0x7725)	WORD	1	Volume Flow - Status	Status/validity of volume flow process value. (read-only)	Bit 0: Under Range (value bounded below) Bit 1: Over Range (value bounded above) Bit 2: Maintenance Required (M) Bit 3: Initial Value (measurement inactive) Bit 4: Function Check (C) Bit 5: Out of Specification (S) Bit 7: Failure (F)	-	-
30502 (0x7726)	WORD	1	Mass Flow - Status	Status/validity of mass flow process value. (read-only)	Bit 0: Under Range (value bounded below) Bit 1: Over Range (value bounded above) Bit 2: Maintenance Required (M) Bit 3: Initial Value (measurement inactive) Bit 4: Function Check (C) Bit 5: Out of Specification (S) Bit 7: Failure (F)	-	-
30503 (0x7727)	WORD	1	Temperature - Status	Status/validity of temperature process value. (read-only)	Bit 0: Under Range (value bounded below) Bit 1: Over Range (value bounded above) Bit 2: Maintenance Required (M) Bit 3: Initial Value (measurement inactive) Bit 4: Function Check (C) Bit 5: Out of Specification (S) Bit 7: Failure (F)	-	-
30504 (0x7728)	WORD	1	Density - Status	Status/validity of density process value. (read-only)	Bit 0: Under Range (value bounded below) Bit 1: Over Range (value bounded above) Bit 2: Maintenance Required (M) Bit 3: Initial Value (measurement inactive) Bit 4: Function Check (C) Bit 5: Out of Specification (S) Bit 7: Failure (F)	-	-
30505 (0x7729)	WORD	1	Concentration 1 - Status	Status/validity of concentration 1 value. (read-only)	Bit 0: Under Range (value bounded below) Bit 1: Over Range (value bounded above) Bit 2: Maintenance Required (M) Bit 3: Initial Value (measurement inactive) Bit 4: Function Check (C) Bit 5: Out of Specification (S) Bit 7: Failure (F)	-	②

Register Address	Type	Qty.	Name	Description	Values	Display Fct. No.	Fn.
30506 (0x772A)	WORD	1	Concentration 2 - Status	Status/validity of concentration 2 value. (read-only)	Bit 0: Under Range (value bounded below) Bit 1: Over Range (value bounded above) Bit 2: Maintenance Required (M) Bit 3: Initial Value (measurement inactive) Bit 4: Function Check (C) Bit 5: Out of Specification (S) Bit 7: Failure (F)	-	②
30507 (0x772B)	WORD	1	Concentration 1 Flow - Status	Status/validity of concentration 1 flow value. (read-only)	Bit 0: Under Range (value bounded below) Bit 1: Over Range (value bounded above) Bit 2: Maintenance Required (M) Bit 3: Initial Value (measurement inactive) Bit 4: Function Check (C) Bit 5: Out of Specification (S) Bit 7: Failure (F)	-	②
30508 (0x772C)	WORD	1	Concentration 2 Flow - Status	Status/validity of concentration 2 flow value. (read-only)	Bit 0: Under Range (value bounded below) Bit 1: Over Range (value bounded above) Bit 2: Maintenance Required (M) Bit 3: Initial Value (measurement inactive) Bit 4: Function Check (C) Bit 5: Out of Specification (S) Bit 7: Failure (F)	-	②

Table 7-4: Modbus data - Measured values and status

① Unit depends on the selected diagnosis value.

② Only available with option "concentration measurement".

7.3 Auxiliary values

Besides the main measured values (see §8.2) the transmitter also provides several sensor-related auxiliary values (diagnostic values).

The data is mapped onto two different address spaces.

Register Address	Type	Qty.	Name	Description	Values	Display Fct. No.	Fn.
2034 (0x07F2)	REAL	2	Drive Level	Output power to the drive coil as a percentage of the maximum possible output. (read-only)	Default: 0.0 Fix unit: [%]	B2.11	-
2036 (0x07F4)	REAL	2	Sensor A Level	Measured input level for sensor A as a percentage of the maximum possible input. (read-only)	Default: 0.0 Fix unit: [%]	B2.12	-
2038 (0x07F6)	REAL	2	Sensor B Level	Measured input level for sensor B as a percentage of the maximum possible input. (read-only)	Default: 0.0 Fix unit: [%]	B2.13	-
2040 (0x07F8)	REAL	2	Strain 1	Measured resistance of the strain gauge 1. (read-only)	Default: 0.0 Fix unit: [Ohm]	B2.8	-
2042 (0x07FA)	REAL	2	Strain 2	Measured resistance of the strain gauge 2. (read-only)	Default: 0.0 Fix unit: [Ohm]	B2.9	-
2044 (0x07FC)	REAL	2	Tube Frequency	Measured oscillation frequency of the measuring tube. (read-only)	Default: 0.0 Fix unit: [Hz]	B2.10	-
2046 (0x07FE)	REAL	2	Two Phase Signal	Two phase signal level. (read-only)	Default: 0.0	B2.14	-
2048(0x0800)	REAL	2	Sensor Electronics Temperature	Temperature of the sensor electronics. (read-only)	Default: 0.0 Unit Class: Temperature	B2.15	-
31000 (0x7918)	REAL	2	Drive Level	Output power to the drive coil as a percentage of the maximum possible output. (read-only)	Default: 0.0 Fix unit: [%]	B2.11	-
31002 (0x791A)	REAL	2	Sensor A Level	Measured input level for sensor A as a percentage of the maximum possible input. (read-only)	Default: 0.0 Fix unit: [%]	B2.12	-

Register Address	Type	Qty.	Name	Description	Values	Display Fct. No.	Fn.
31004 (0x791C)	REAL	2	Sensor B Level	Measured input level for sensor B as a percentage of the maximum possible input. (read-only)	Default: 0.0 Fix unit: [%]	B2.13	-
31006 (0x791E)	REAL	2	Strain 1	Measured resistance of the strain gauge 1. (read-only)	Default: 0.0 Fix unit: [Ohm]	B2.8	-
31008 (0x7920)	REAL	2	Strain 2	Measured resistance of the strain gauge 2. (read-only)	Default: 0.0 Fix unit: [Ohm]	B2.9	-
31010 (0x7922)	REAL	2	Tube Frequency	Measured oscillation frequency of the measuring tube. (read-only)	Default: 0.0 Fix unit: [Ohm]	B2.10	-
31012 (0x7924)	REAL	2	Two Phase Signal	Two phase signal level. (read-only)	Default: 0.0	B2.14	-
31014 (0x7926)	REAL	2	Sensor Electronics Temperature	Temperature of the sensor electronics. (read-only)	Default: 0.0 Unit Class: Temperature	B2.15	-

Table 7-5: Modbus data - Auxiliary values

7.4 Totalisers

Modbus provides access to two or three internal totalisers. The number of available totalisers depends on the hardware configuration of the transmitter.

The totalisers are comprehensively adjustable and controllable via Modbus.

7.4.1 Status and values

The totaliser values are available in two different formats (32-bit / REAL and 64-bit / LREAL). They are mapped onto multiple register addresses for compatibility reasons. The totaliser status can be used to check the quality/validity of the associated value. The unit depends on the selected totaliser measurement (for details refer to *Configuration* on page 52) since each totaliser can be set up to accumulate mass or volume.

Register Address	Type	Qty.	Name	Description	Values	Display Fct. No.	Fn.
259 (0x0103)	REAL	2	Totaliser 1 - Value (REAL)	Totaliser 1 value in 32-bit format. (read-only)	Default: 0.0 Unit class: Volume, Mass	-	①
261 (0x0105)	REAL	2	Totaliser 2 - Value (REAL)	Totaliser 2 value in 32-bit format. (read-only)	Default: 0.0 Unit class: Volume, Mass	-	①
2100 (0x0834)	WORD	1	Totaliser 1 - Status	Status/validity of totaliser 1 value. (read-only)	Bit 0: Under Range (value bounded below) Bit 1: Over Range (value bounded above) Bit 2: Maintenance Required (M) Bit 3: Initial Value (measurement inactive) Bit 4: Function Check (C) Bit 5: Out of Specification (S) Bit 7: Failure (F)	-	-
2101 (0x0835)	REAL	2	Totaliser 1 - Value (REAL)	Totaliser 1 value in 32-bit format. (read-only)	Default: 0.0 Unit class: Volume, Mass	-	①
2103 (0x0837)	WORD	1	Totaliser 2 - Status	Status/validity of totaliser 2 value. (read-only)	Bit 0: Under Range (value bounded below) Bit 1: Over Range (value bounded above) Bit 2: Maintenance Required (M) Bit 3: Initial Value (measurement inactive) Bit 4: Function Check (C) Bit 5: Out of Specification (S) Bit 7: Failure (F)	-	-

Register Address	Type	Qty.	Name	Description	Values	Display Fct. No.	Fn.
2104 (0x0838)	REAL	2	Totaliser 2 - Value (REAL)	Totaliser 2 value in 32-bit format. (read-only)	Default: 0.0 Unit class: Volume, Mass	-	①
2106 (0x083A)	WORD	1	Totaliser 3 - Status	Status/validity of totaliser 3 value. (read-only)	Bit 0: Under Range (value bounded below) Bit 1: Over Range (value bounded above) Bit 2: Maintenance Required (M) Bit 3: Initial Value (measurement inactive) Bit 4: Function Check (C) Bit 5: Out of Specification (S) Bit 7: Failure (F)	-	②
2107 (0x083B)	REAL	2	Totaliser 3 - Value (REAL)	Totaliser 3 value in 32-bit format. (read-only)	Default: 0.0 Unit class: Volume, Mass	-	① ②
2200 (0x0898)	WORD	1	Totaliser 1 - Status	Status/validity of totaliser 1 value. (read-only)	Bit 0: Under Range (value bounded below) Bit 1: Over Range (value bounded above) Bit 2: Maintenance Required (M) Bit 3: Initial Value (measurement inactive) Bit 4: Function Check (C) Bit 5: Out of Specification (S) Bit 7: Failure (F)	-	-
2201 (0x0899)	LREAL	4	Totaliser 1 - Value (LREAL)	Totaliser 1 value in 64-bit format. (read-only)	Default: 0.0 Unit class: Volume, Mass	-	①
2205 (0x089D)	WORD	1	Totaliser 2 - Status	Status/validity of totaliser 2 value. (read-only)	Bit 0: Under Range (value bounded below) Bit 1: Over Range (value bounded above) Bit 2: Maintenance Required (M) Bit 3: Initial Value (measurement inactive) Bit 4: Function Check (C) Bit 5: Out of Specification (S) Bit 7: Failure (F)	-	-
2206 (0x089E)	LREAL	4	Totaliser 2 - Value (LREAL)	Totaliser 2 value in 64-bit format. (read-only)	Default: 0.0 Unit class: Volume, Mass	-	①

Register Address	Type	Qty.	Name	Description	Values	Display Fct. No.	Fn.
2210 [0x08A2]	WORD	1	Totaliser 3 - Status	Status/validity of totaliser 3 value. (read-only)	Bit 0: Under Range (value bounded below) Bit 1: Over Range (value bounded above) Bit 2: Maintenance Required (M) Bit 3: Initial Value (measurement inactive) Bit 4: Function Check (C) Bit 5: Out of Specification (S) Bit 7: Failure (F)	-	②
2211 [0x08A3]	LREAL	4	Totaliser 3 - Value (LREAL)	Totaliser 3 value in 64-bit format. (read-only)	Default: 0.0 Unit class: Volume, Mass	-	① ②
32000 [0x7D00]	LREAL	4	Totaliser 1 - Value (LREAL)	Totaliser 1 value in 64-bit format. (read-only)	Default: 0.0 Unit class: Volume, Mass	-	①
32004 [0x7D04]	LREAL	4	Totaliser 2 - Value (LREAL)	Totaliser 2 value in 64-bit format. (read-only)	Default: 0.0 Unit class: Volume, Mass	-	①
32008 [0x7D08]	LREAL	4	Totaliser 3 - Value (LREAL)	Totaliser 3 value in 64-bit format. (read-only)	Default: 0.0 Unit class: Volume, Mass	-	① ②
32100 [0x7D64]	REAL	2	Totaliser 1 - Value (REAL)	Totaliser 1 value in 32-bit format. (read-only)	Default: 0.0 Unit class: Volume, Mass	-	①
32102 [0x7D66]	REAL	2	Totaliser 2 - Value (REAL)	Totaliser 2 value in 32-bit format. (read-only)	Default: 0.0 Unit class: Volume, Mass	-	①
32104 [0x7D68]	REAL	2	Totaliser 3 - Value (REAL)	Totaliser 3 value in 32-bit format. (read-only)	Default: 0.0 Unit class: Volume, Mass	-	① ②

Table 7-6: Modbus data - Totaliser - Status and values

① The unit depends on selected measurand in "Totaliser x - Measurement" (volume or mass).

② Totaliser 3 only available for certain I/O options (if any other I/O, e.g. current output, is available on terminals A or B).

7.4.2 Configuration

The totalisers can be configured using the parameters describes in this section.

Register Address	Type	Qty.	Name	Description	Values	Display Fct. No.	Fn.
3100 (0x0C1C)	UINT	1	Totaliser 1 - Measurement	Select the measurement for the totaliser.	1 = Volume Flow (default) 2 = Mass Flow 14 = Concentration 1 Mass Flow 15 = Concentration 1 Volume Flow 16 = Concentration 2 Mass Flow 17 = Concentration 2 Volume Flow	C3.1.2	① ②
3101 (0x0C1D)	UINT	1	Totaliser 1 - Function	Select the counting direction of the totaliser.	0 = Off 1 = Absolute Total 2 = Incremental Total (default) 3 = Decremental Total	C3.1.1	①
3102 (0x0C1E)	REAL	2	Totaliser 1 - Damping	Defines the time constant of the digital filter for damping the measurement value (noise suppression).	Default: 0.0 Range: 0.0...100.0 Fix unit: [s]	C3.1.4	①
3104 (0x0C20)	REAL	2	Totaliser 1 - Low Flow Cut-off - Threshold	Flow rate below which the selected measurement value is not used by the totaliser.	Default: 0.0 Unit class: Volumetric Flow, Mass Flow	C3.1.3	③
3106 (0x0C22)	REAL	2	Totaliser 1 - Low Flow Cut-off - Hysteresis	Hysteresis value for the low flow cut-off threshold value.	Default: 0.0 Unit class: Volumetric Flow, Mass Flow	C3.1.3	③
3200 (0x0C80)	UINT	1	Totaliser 2 - Measurement	Select the measurement for the totaliser.	1 = Volume Flow (default) 2 = Mass Flow 14 = Concentration 1 Mass Flow 15 = Concentration 1 Volume Flow 16 = Concentration 2 Mass Flow 17 = Concentration 2 Volume Flow	C3.2.2	① ②
3201 (0x0C81)	UINT	1	Totaliser 2 - Function	Select the counting direction of the totaliser.	0 = Off 1 = Absolute Total 2 = Incremental Total (default) 3 = Decremental Total	C3.2.1	①
3202 (0x0C82)	REAL	2	Totaliser 2 - Damping	Defines the time constant of the digital filter for damping the measurement value (noise suppression).	Default: 0.0 Range: 0.0...100.0 Fix unit: [s]	C3.2.4	①

Register Address	Type	Qty.	Name	Description	Values	Display Fct. No.	Fn.
3204 (0x0C84)	REAL	2	Totaliser 2 - Low Flow Cut-off - Threshold	Flow rate below which the selected measurement value is not used by the totaliser.	Default: 0.0 Unit class: Volumetric Flow, Mass Flow	C3.2.3	③
3206 (0x0C86)	REAL	2	Totaliser 2 - Low Flow Cut-off - Hysteresis	Hysteresis value for the low flow cut-off threshold value.	Default: 0.0 Unit class: Volumetric Flow, Mass Flow	C3.2.3	③
3300 (0x0CE4)	UINT	1	Totaliser 3 - Measurement	Select the measurement for the totaliser.	1 = Volume Flow (default) 2 = Mass Flow 14 = Concentration 1 Mass Flow 15 = Concentration 1 Volume Flow 16 = Concentration 2 Mass Flow 17 = Concentration 2 Volume Flow	C3.3.2	① ② ④
3301 (0x0CE5)	UINT	1	Totaliser 3 - Function	Select the counting direction of the totaliser.	0 = Off 1 = Absolute Total 2 = Incremental Total (default) 3 = Decremental Total	C3.3.1	① ④
3302 (0x0CE6)	REAL	2	Totaliser 3 - Damping	Defines the time constant of the digital filter for damping the measurement value (noise suppression).	Default: 0.0 Range: 0.0...100.0 Fix unit: [s]	C3.3.4	① ④
3304 (0x0CE8)	REAL	2	Totaliser 3 - Low Flow Cut-off - Threshold	Flow rate below which the selected measurement value is not used by the totaliser.	Default: 0.0 Unit class: Volumetric Flow, Mass Flow	C3.3.3	③ ④
3306 (0x0CEA)	REAL	2	Totaliser 3 - Low Flow Cut-off - Hysteresis	Hysteresis value for the low flow cut-off threshold value.	Default: 0.0 Unit class: Volumetric Flow, Mass Flow	C3.3.3	③ ④

Table 7-7: Modbus data - Totaliser - Configuration

- ① Execute the "Apply Changes" command to apply and to save changes (refer to "Device Control Command").
- ② Concentration related settings only available with option "concentration measurement".
- ③ The unit depends on selected measurand in "Totaliser x - Measurement" (volume or mass).
- ④ Totaliser 3 only available for certain I/O options (if any other I/O, e.g. current output, is available on terminals A or B).

7.4.3 Set and control

The totalisers can be set and controlled using parameters described in this section.

Register Address	Type	Qty.	Name	Description	Values	Display Fct. No.	Fn.
3010 (0x0BC2)	UINT	1	Totaliser 1 - Control	Start, stop or reset the totaliser.	0 = Stop/Stopped (default) 1 = Start/Running 2 = Reset	C3.1.6, C3.1.8, C3.1.9	-
3011 (0x0BC3)	REAL	2	Totaliser 1 - Set Value	Set totaliser to a desired value.	Default: 0.0 Unit class: Volume, Mass	C3.1.7	①
3020 (0x0BCC)	UINT	1	Totaliser 2 - Control	Start, stop or reset the totaliser.	0 = Stop/Stopped (default) 1 = Start/Running 2 = Reset	C3.2.6, C3.2.8, C3.2.9	-
3021 (0x0BCD)	REAL	2	Totaliser 2 - Set Value	Set totaliser to a desired value.	Default: 0.0 Unit class: Volume, Mass	C3.2.7	①
3030 (0x0BD6)	UINT	1	Totaliser 3 - Control	Start, stop or reset the totaliser.	0 = Stop/Stopped (default) 1 = Start/Running 2 = Reset	C3.3.6, C3.3.8, C3.3.9	②
3031 (0x0BD7)	REAL	2	Totaliser 3 - Set Value	Set totaliser to a desired value.	Default: 0.0 Unit class: Volume, Mass	C3.3.7	① ②

Table 7-8: Modbus data - Totaliser - Set and control

① The unit depends on selected measurand in "Totaliser x - Measurement" (volume or mass).

② Totaliser 3 only available for certain I/O options (if any other I/O, e.g. current output, is available on terminals A or B).

Coil Address	Name	Description	Values	Display Fct. No.	Fn.
3000 (0x0BB8)	Totaliser 1 Control	Start, stop or reset the totaliser.	0 = Stop Totaliser / Totaliser not running (default) 1 = Start Totaliser / Totaliser running	C3.1.6	-
3001 (0x0BB9)	Totaliser 2 Control	Start, stop or reset the totaliser.	0 = Stop Totaliser / Totaliser not running (default) 1 = Start Totaliser / Totaliser running	C3.2.6	-
3002 (0x0BBA)	Totaliser 3 Control	Start, stop or reset the totaliser.	0 = Stop Totaliser / Totaliser not running (default) 1 = Start Totaliser / Totaliser running	C3.3.6	①
3003 (0x0BBB)	Totaliser 1 Reset	Reset the totaliser value to zero.	0 = Not used / no action (default) 1 = Perform action	C3.1.8, C3.1.9	-
3004 (0x0BBC)	Totaliser 2 Reset	Reset the totaliser value to zero.	0 = Not used / no action (default) 1 = Perform action	C3.2.8, C3.2.9	-
3005 (0x0BBD)	Totaliser 3 Reset	Reset the totaliser value to zero.	0 = Not used / no action (default) 1 = Perform action	C3.3.8, C3.3.9	①

Table 7-9: Modbus data - Totaliser - Set and control - Coils

① Totaliser 3 only available for certain I/O options (if any other I/O, e.g. current output, is available on terminals A or B).

7.5 Sensor setup and calibration

The sensor can be configured using the parameters described in this section. Some of the parameters are only available in expert mode. For further information refer to the section "Operation / Measurement functions / Flow (C1.1.0 Flow)" in the standard documentation of the transmitter.

The "Zero Calibration" is described in detail in the section "Operation / Calibration functions / Zero calibration (C1.1.1 Calibrate Zero)" in the standard documentation of the transmitter.

Register Address	Type	Qty.	Name	Description	Values	Display Fct. No.	Fn.
4000 (0x0FA0)	UINT	1	Flow Direction	Defines polarity of flow direction.	1 = Forwards (default) 2 = Backwards	C1.1.4	①
4001 (0x0FA1)	REAL	2	Process Noise Damping	Filtering period used to remove noise from the mass flow reading.	Default: 1.0 Range: 0.01...30.0 Fix unit: [s]	C1.1.5	①
4003 (0x0FA3)	REAL	2	Low Flow Cut-off	The flow rate (as a percentage of nominal flow) below which the mass flow reading is automatically set to 0.	Default: 0.2 Range: 0.0...20.0 Fix unit: [%]	C1.1.6	①
4005 (0x0FA5)	REAL	2	Pipe Diameter	Sets the pipe diameter to calculate the flow velocity.	Default: 0.01 Range: 0.001...0.5 Fix unit: [m]	C1.1.9	①
4007 (0x0FA7)	REAL	2	Pressure Suppression - Low Flow Cut-off	When pressure suppression is active, the cut-off value that is applied in addition to the low flow cut-off.	Default: 0.0 Range: 0.0...10.0 Fix unit: [%]	C1.1.7	①
4009 (0x0FA9)	REAL	2	Pressure Suppression - Time	The period of application of the pressure suppression during which the pressure suppression cut-off is applied.	Default: 0.0 Range: 0.0...20.0 Fix unit: [s]	C1.1.8	①
4011 (0x0FAB)	REAL	2	Zero Additional Offset	Fix offset that is applied to the mass flow value.	Default: 0.0 Range: -32.0...32.0 Unit Class: Mass Flow	C1.1.2	①
4013 (0x0FAD)	REAL	2	Flow Correction	Use defined correction factor for adjusting the flow rate (i.e. compensation of process variations).	Default: 0.0 Range: -100.0...100.0 Fix unit: [%]	C1.1.3	①
4015 (0x0FAF)	UINT	1	Density Mode	The mode by which the density value is generated.	0 = Process (default) 1 = Fixed 2 = Referred 3 = Standard	C1.1.2	①
4016 (0x0FB0)	REAL	2	Fixed Density Value	Sets the fixed value (e.g. standard density) for the density.	Default: 998.2 Range: 0.08...5000.0 Unit Class: Density	C1.2.3	① ②
4018 (0x0FB2)	REAL	2	Referred Density Temperature	Sets the reference temperature for the reference density option.	Default: 293.15 Range: 28.15...773.15 Unit Class: Temperature	C1.2.4	① ③

Register Address	Type	Qty.	Name	Description	Values	Display Fct. No.	Fn.
4020 (0x0FB4)	REAL	2	Referred Density Slope	Sets the slope for the reference density option.	Default: 0.0 Range: 0.0...65.0	C1.2.5	① ③
4022 (0x0FB6)	REAL	2	Standard Density Temperature	Density reference temperature to calculate standard density.	Default: 293.15 Range: 28.15...773.15 Unit Class: Temperature	C1.2.6	① ③
4024 (0x0FB8)	REAL	2	Standard Density k0	Coefficient k0 to calculate standard density.	Default: 346.423 Range: 0.0...5000.0	C1.2.7	① ④
4026 (0x0FBA)	REAL	2	Standard Density k1	Coefficient k1 to calculate standard density	Default: 0.439 Range: -100.0...100.0	C1.2.8	① ④
4028 (0x0FBC)	REAL	2	Standard Density k2	Coefficient k2 to calculate standard density	Default: 0.0 Range: -10.0...10.0	C1.2.9	① ④
4030 (0x0FBE)	UINT	1	System Control - Function	Sets the system control action.	1 = Off / No Action (default) 2 = Flow = 0	C1.4.1	①
4031 (0x0FBF)	UINT	1	System Control - Variable	Sets the condition for activating the system control.	0 = Density 1 = Temperature (default)	C1.4.2	①
4032 (0x0FC0)	REAL	2	System Control - Min Density	Lower limit for the density condition.	Default: 500.0 Range: 0.08...5000.0 Unit Class: Density	C1.4.4	① ⑤
4034 (0x0FC2)	REAL	2	System Control - Max Density	Upper limit for the density condition.	Default: 2000.0 Range: 0.08...5000.0 Unit Class: Density	C1.4.3	① ⑤
4036 (0x0FC4)	REAL	2	System Control - Min Temperature	Lower limit for the temperature condition.	Default: 283.15 Range: 73.0...773.0 Unit Class: Temperature	C1.4.4	① ⑥
4038 (0x0FC6)	REAL	2	System Control - Max Temperature	Upper limit for the temperature condition.	Default: 373.15 Range: 73.0...773.0 Unit Class: Temperature	C1.4.3	① ⑥
4200 (0x1068)	UINT	1	Start Zero Calibration	Initiate a calibration of the zero flow offset.	0 = Not used / no action (default) 1 = Start the Zero Calibration Procedure / Procedure is running	C1.1.1	-

Table 7-10: Modbus data - Sensor - Setup

- ① Execute the "Apply Changes" command to apply and to save changes (refer to "Device Control Command").
- ② Used only if density mode "Fixed" has been selected.
- ③ Used only if density mode "Referred" has been selected.
- ④ Used only if density mode "Standard" has been selected.
- ⑤ The data can also be accessed using Modbus Function Code 8 "Diagnostics".
- ⑥ Limits are used if "System control - Variable" is set to "Density".

Coil Address	Name	Description	Values	Display Fct. No.	Fn.
4200	Start Zero Calibration	Initiate a calibration of the zero flow offset.	0 = Not used / no action (default) 1 = Start the Zero Calibration procedure / Procedure is running	C1.1.1	-

Table 7-11: Modbus data - Sensor - Setup - Coils

7.6 Sensor diagnostics

The sensor has two diagnosis channels ("Diagnosis 1" and "Diagnosis 2"; for details refer to *Measured values and status* on page 39) that can provide one of the auxiliary/diagnosis values each.

The two-phase flow feature is described in detail in the section "Operation / Measurement functions / Detection of 2 phase flow" in the standard documentation of the transmitter.

Register Address	Type	Qty.	Name	Description	Values	Display Fct. No.	Fn.
4301 (0x10CD)	REAL	2	Two Phase Threshold	Sets the process-dependent threshold of the two phase signal status (Status Group - Process: Two Phase Signal). Value 0 disables the two phase detection.	Default: 0.0 Range: 0.0...1000.0	C1.5.1	①
4303 (0x10CF)	UINT	1	Selector for "Diagnosis 1 - Value"	Select which sensor diagnosis value is transmitted via "Diagnosis 1 - Value".	255 = Deactivated (default) 9 = Tube Frequency [Hz] 10 = Strain 1 [Ohm] 11 = Strain 2 [Ohm] 14 = Drive Level [%] 25 = Two Phase Signal 31 = Sensor Average [%] 32 = Sensor Deviation [%]	C1.5.2	①
4304 (0x10D0)	UINT	1	Selector for "Diagnosis 2 - Value"	Select which sensor diagnosis value is transmitted via "Diagnosis 2 - Value".	255 = Deactivated (default) 9 = Tube Frequency [Hz] 10 = Strain 1 [Ohm] 11 = Strain 2 [Ohm] 14 = Drive Level [%] 25 = Two Phase Signal 31 = Sensor Average [%] 32 = Sensor Deviation [%]	C1.5.3	①

Table 7-12: Modbus data - Sensor - Diagnostics

① Execute the "Apply Changes" command to apply and to save changes (refer to "Device Control Command").

7.7 Configuration of units

The configuration of units (also known as engineering units or units of measurement) can be selected via Modbus or display in order to adapt to the application in the best possible way.

The configuration changes the unit for the entire unit class. Example: Setting unit class mass to kg will affect all data items of unit class "mass".

Some unit classes can be set to "free unit" where a custom conversion factor is used that can be freely selected.

$$\text{value}_{\text{converted}} = \text{value}_{\text{original}} \times \text{factor}_{\text{free}}$$

Further details about "free units" can be found in the the section "Operation / Function tables / Set free units" in the standard documentation of the transmitter.

The configuration is valid for display and Modbus at the same time. Changing the units at the display affects values on Modbus and vice versa.

Special notes:

- gal(UK) = imperial gallon (liquid) = 4.54609 L
- gal = gallon (U.S. liquid) = 231 in³
- ton(UK) = LTon = long ton = british ton = 2240 lb
- ton = STon = short ton = U.S. ton = 2000 lb
- bbl = barrel (U.S. petroleum) = 42 gal
- SG = specific gravity

Each unit is represented by a unique unit code. The unit code is assembled from:

- MSB: Device Variable Classification Code
- LSB: Unit Code from Engineering Unit Code Expansion Tables

(refer to HART Field Communications Protocol Specification Revision 6 and later)

Example:

- MSB = 0x 42 = Unit Class Volume Flow
- LSB = 0x 11 = Unit L/min
-> Unique Modbus unit code for L/min = 0x 42 11 = 16913

Register Address	Type	Qty.	Name	Description	Values	Display Fct. No.	Fn.
8000 (0x1F40)	UINT	1	Volume Flow - Unit	Select unit for unit class "volume flow".	16911 (0x420F) = ft ³ /min 16912 (0x4210) = gal/min 16913 (0x4211) = L/min 16914 (0x4212) = gal(UK)/min 16915 (0x4213) = m ³ /h 16918 (0x4216) = gal/s 16920 (0x4218) = L/s 16922 (0x421A) = ft ³ /s 16924 (0x421C) = m ³ /s (default) 16926 (0x421E) = gal(UK)/h 17026 (0x4282) = ft ³ /h 17027 (0x4283) = m ³ /min 17030 (0x4286) = bbl/h 17031 (0x4287) = bbl/d 17032 (0x4288) = gal/h 17033 (0x4289) = gal(UK)/s 17034 (0x428A) = L/h 17141 (0x42F5) = free	C6.5.1	①
8001 (0x1F41)	UINT	1	Mass Flow - Unit	Select unit for unit class "mass flow".	18502 (0x4846) = g/s 18503 (0x4847) = g/min 18504 (0x4848) = g/h 18505 (0x4849) = kg/s (default) 18506 (0x484A) = kg/min 18507 (0x484B) = kg/h 18509 (0x484D) = t/min 18510 (0x484E) = t/h 18512 (0x4850) = lb/s 18513 (0x4851) = lb/min 18514 (0x4852) = lb/h 18516 (0x4854) = ton/min 18517 (0x4855) = ton/h 18519 (0x4857) = ton(UK)/h 18679 (0x48F7) = free	C6.5.4	① ②
8002 (0x1F42)	UINT	1	Density - Unit	Select unit for unit class "density".	18778 (0x495A) = SG 18780 (0x495C) = kg/m ³ (default) 18781 (0x495D) = lb/gal 18782 (0x495E) = lb/ft ³ 18784 (0x4960) = kg/L 18936 (0x49F8) = free	C6.5.16	① ②
8003 (0x1F43)	UINT	1	Volume - Unit	Select unit for unit class "volume".	17448 (0x4428) = gal 17449 (0x4429) = L 17450 (0x442A) = gal(UK) 17451 (0x442B) = m ³ (default) 17454 (0x442E) = bbl 17519 (0x446F) = yd ³ 17520 (0x4470) = ft ³ 17521 (0x4471) = in ³ 17644 (0x44EC) = hL 17649 (0x44F1) = mL 17650 (0x44F2) = free	C6.5.10	① ②

Register Address	Type	Qty.	Name	Description	Values	Display Fct. No.	Fn.
8004 (0x1F44)	UINT	1	Mass - Unit	Select unit for unit class "mass".	18236 (0x473C) = g 18237 (0x473D) = kg (default) 18238 (0x473E) = t 18239 (0x473F) = lb 18240 (0x4740) = ton 18241 (0x4741) = ton(UK) 18301 (0x477D) = oz 18416 (0x47F0) = mg 18420 (0x47F4) = free	C6.5.13	① ②
8005 (0x1F45)	UINT	1	Velocity - Unit	Select unit for unit class "velocity".	17172 (0x4314) = ft/s 17173 (0x4315) = m/s (default)	C6.5.7	① ②
8006 (0x1F46)	UINT	1	Temperature - Unit	Select unit for unit class "temperature".	16416 (0x4020) = °C 16417 (0x4021) = °F 16419 (0x4023) = K (default)	C6.5.9	① ②
8100 (0x1FA4)	REAL	2	Volume Flow - Conversion Factor	Conversion factor if "Volume Flow - Unit" is set to "free" (output = factor x value [m ³ /s]).	Default: 10.0	C6.5.3	① ②
8102 (0x1FA6)	REAL	2	Mass Flow - Conversion Factor	Conversion factor if "Mass Flow - Unit" is set to "free" (output = factor x value [kg/s]).	Default: 1.0	C6.5.6	① ②
8104 (0x1FA8)	REAL	2	Density - Conversion Factor	Conversion factor if "Density - Unit" is set to "free" (output = factor x value [kg/m ³]).	Default: 1.0	C6.5.18	① ②
8106 (0x1FAA)	REAL	2	Volume - Conversion Factor	Conversion factor if "Volume - Unit" is set to "free" (output = factor x value [m ³]).	Default: 10.0	C6.5.12	① ②
8108 (0x1FAC)	REAL	2	Mass - Conversion Factor	Conversion factor if "Mass - Unit" is set to "free" (output = factor x value [kg]).	Default: 1.0	C6.5.15	① ②

Table 7-13: Modbus data - Units

- ① Execute the "Apply Changes" command to apply and to save changes (refer to "Device Control Command").
② The display and Modbus interface work with the same configured units.

7.8 Concentration

The concentration feature is an optional extra that can be requested when ordering the flowmeter or purchased after delivery.

It is described in the separate "Concentration" supplementary instructions.

If you do not have this document, please contact the nearest office or download it from the manufacturer's internet site.

7.8.1 Basic settings

This section describes parameters to setup the concentration measurement.

Register Address	Type	Qty.	Name	Description	Values	Display Fct. No.	Fn.
4050 (0x0FD2)	UINT	1	Concentration 1 - Function	Determines the type of measurement calculation that the meter performs for concentration 1.	1 = Off (default) 2 = Brix 3 = % Mass 4 = Baume 144 5 = Baume 145 6 = % NaOH 7 = Plato 8 = % Volume 9 = API 10 = % Alcohol by Mass 11 = % Alcohol by Volume	C1.3.2	① ②
4051 (0x0FD3)	REAL	2	Concentration 1 - Offset	Sets an additional offset for the concentration measurement. Can be used to correct for differences between the measured value and the reference value.	Default: 0.0 Range: -100.0...100.0 Fix unit: [%]	C1.3.2	① ②
4053 (0x0FD5)	UINT	1	Concentration 1 - Product	Determines the method by which the concentration value is represented when a mixture of two products (A and B) are being measured.	0 = % of Product A (default) 1 = % of Product B	C1.3.2	① ②
4054 (0x0FD6)	UINT	1	Concentration 2 - Function	Determines the type of measurement calculation that the meter performs for concentration 2.	1 = Off (default) 2 = Brix 3 = % Mass 4 = Baume 144 5 = Baume 145 6 = % NaOH 7 = Plato 8 = % Volume 9 = API 10 = % Alcohol by Mass 11 = % Alcohol by Volume	C1.3.3	① ②
4055 (0x0FD7)	REAL	2	Concentration 2 - Offset	Sets an additional offset for the concentration measurement. Can be used to correct for differences between the measured value and the reference value.	Default: 0.0 Range: -100.0...100.0 Fix unit: [%]	C1.3.3	① ②
4057 (0x0FD9)	UINT	1	Concentration 2 - Product	Determines the method by which the concentration value is represented when a mixture of two products (A and B) are being measured.	0 = % of Product A (default) 1 = % of Product B	C1.3.3	① ②

Register Address	Type	Qty.	Name	Description	Values	Display Fct. No.	Fn.
4058 (0x0FDA)	UINT	1	Concentration Data Select	Select which of the two concentration parameters set is active.	0 = Concentration Data Set 1 (default) 1 = Concentration Data Set 2	C1.3.1	① ②

Table 7-14: Modbus data - Concentration - Configuration

① Only available with option "concentration measurement".

② Execute the "Apply Changes" command to apply and to save changes (refer to "Device Control Command").

7.8.2 Data set 1

Concentration coefficients stored in concentration data set 1.

Register Address	Type	Qty.	Name	Description	Values	Display Fct. No.	Fn.
4059 (0x0FDB)	UINT	1	Concentration Data 1 - Coefficient CCF01	Defines the use of linear or non-linear coefficients to measure concentration.	0 = Linear (default) 1 = Non-Linear	C1.3.4	① ②
4060 (0x0FDC)	REAL	2	Concentration Data 1 - Coefficient CCF02	Density of product A in g/cm ³ .	Default: 0.0 Range: -9.0e+07...9.0e+07 Fix unit: [g/cm ³]	C1.3.4	① ②
4062 (0x0FDE)	REAL	2	Concentration Data 1 - Coefficient CCF03	Temperature coefficient for product A.	Default: 0.0 Range: -9.0e+07...9.0e+07	C1.3.4	① ②
4064 (0x0FE0)	REAL	2	Concentration Data 1 - Coefficient CCF04	Temperature coefficient squared for product A.	Default: 0.0 Range: -9.0e+07...9.0e+07	C1.3.4	① ②
4066 (0x0FE2)	UINT	1	Concentration Data 1 - Coefficient CCF05	Definition of the carrier (product B) when performing general concentration calculation.	0 = Pure Water (998.2 kg/m ³ at 20°C) (default) 1 = Town Water (999.7 kg/m ³ at 20°C) 2 = Other	C1.3.4	① ②
4067 (0x0FE3)	REAL	2	Concentration Data 1 - Coefficient CCF06	Temperature coefficient squared for "Product B".	Default: 0.0 Range: -9.0e+07...9.0e+07	C1.3.4	① ②
4069 (0x0FE5)	REAL	2	Concentration Data 1 - Coefficient CCF07	Temperature coefficient squared for "Product B" (if CCF05 = Other).	Default: 0.0 Range: -9.0e+07...9.0e+07	C1.3.4	① ②
4071 (0x0FE7)	REAL	2	Concentration Data 1 - Coefficient CCF08	Defines non-linear equation if CCF01 is set to "Non-Linear".	Default: 0.0 Range: -9.0e+07...9.0e+07	C1.3.4	① ②

Register Address	Type	Qty.	Name	Description	Values	Display Fct. No.	Fn.
4073 (0x0FE9)	REAL	2	Concentration Data 1 - Coefficient CCF09	Defines non-linear equation if CCF01 is set to "Non-Linear". Consult the manufacturer for settings.	Default: 0.0 Range: -9.0e+07...9.0e+07	C1.3.4	① ②
4075 (0x0FEB)	REAL	2	Concentration Data 1 - Coefficient CCF10	Defines non-linear equation if CCF01 is set to "Non-Linear". Consult the manufacturer for settings.	Default: 0.0 Range: -9.0e+07...9.0e+07	C1.3.4	① ②
4077 (0x0FED)	REAL	2	Concentration Data 1 - Coefficient CCF11	Defines non-linear equation if CCF01 is set to "Non-Linear". Consult the manufacturer for settings.	Default: 0.0 Range: -9.0e+07...9.0e+07	C1.3.4	① ②
4079 (0x0FEF)	REAL	2	Concentration Data 1 - Coefficient CCF12	Defines non-linear equation if CCF01 is set to "Non-Linear". Consult the manufacturer for settings.	Default: 0.0 Range: -9.0e+07...9.0e+07	C1.3.4	① ②

Table 7-15: Modbus data - Concentration - Data Set 1

① Only available with option "concentration measurement".

② Execute the "Apply Changes" command to apply and to save changes (refer to "Device Control Command").

7.8.3 Data set 2

Concentration coefficients stored in concentration data set 2.

Register Address	Type	Qty.	Name	Description	Values	Display Fct. No.	Fn.
4081 (0x0FF1)	UINT	1	Concentration Data 2 - Coefficient CCF01	Defines the use of linear or non-linear coefficients to measure concentration.	0 = Linear (default) 1 = Non-Linear	C1.3.5	① ②
4082 (0x0FF2)	REAL	2	Concentration Data 2 - Coefficient CCF02	Density of product A in g/cm ³ .	Default: 0.0 Range: -9.0e+07...9.0e+07 Fix unit: [g/cm ³]	C1.3.5	① ②
4084 (0x0FF4)	REAL	2	Concentration Data 2 - Coefficient CCF03	Temperature coefficient for product A.	Default: 0.0 Range: -9.0e+07...9.0e+07	C1.3.5	① ②
4086 (0x0FF6)	REAL	2	Concentration Data 2 - Coefficient CCF04	Temperature coefficient squared for product A.	Default: 0.0 Range: -9.0e+07...9.0e+07	C1.3.5	① ②
4088 (0x0FF8)	UINT	1	Concentration Data 2 - Coefficient CCF05	Definition of the carrier (product B) when performing general concentration calculation.	0 = Pure Water (998.2 kg/m ³ at 20°C) (default) 1 = Town Water (999.7 kg/m ³ at 20°C) 2 = Other	C1.3.5	① ②
4089 (0x0FF9)	REAL	2	Concentration Data 2 - Coefficient CCF06	Temperature coefficient squared for "Product B".	Default: 0.0 Range: -9.0e+07...9.0e+07 Fix unit: [g/cm ³]	C1.3.5	① ②
4091 (0x0FFB)	REAL	2	Concentration Data 2 - Coefficient CCF07	Temperature coefficient squared for "Product B" (if CCF05 = Other).	Default: 0.0 Range: -9.0e+07...9.0e+07	C1.3.5	① ②
4093 (0x0FFD)	REAL	2	Concentration Data 2 - Coefficient CCF08	Defines non-linear equation if CCF01 is set to "Non-Linear".	Default: 0.0 Range: -9.0e+07...9.0e+07	C1.3.5	① ②
4095 (0x0FFF)	REAL	2	Concentration Data 2 - Coefficient CCF09	Defines non-linear equation if CCF01 is set to "Non-Linear". Consult the manufacturer for settings.	Default: 0.0 Range: -9.0e+07...9.0e+07	C1.3.5	① ②
4097 (0x1001)	REAL	2	Concentration Data 2 - Coefficient CCF10	Defines non-linear equation if CCF01 is set to "Non-Linear". Consult the manufacturer for settings.	Default: 0.0 Range: -9.0e+07...9.0e+07	C1.3.5	① ②

Register Address	Type	Qty.	Name	Description	Values	Display Fct. No.	Fn.
4099 (0x1003)	REAL	2	Concentration Data 2 - Coefficient CCF11	Defines non-linear equation if CCF01 is set to "Non-Linear". Consult the manufacturer for settings.	Default: 0.0 Range: -9.0e+07...9.0e+07	C1.3.5	① ②
4101 (0x1005)	REAL	2	Concentration Data 2 - Coefficient CCF12	Defines non-linear equation if CCF01 is set to "Non-Linear". Consult the manufacturer for settings.	Default: 0.0 Range: -9.0e+07...9.0e+07	C1.3.5	① ②

Table 7-16: Modbus data - Concentration - Data Set 2

① Only available with option "concentration measurement".

② Execute the "Apply Changes" command to apply and to save changes (refer to "Device Control Command").

7.9 Configuration of NE 107 status groups

The transmitter congregates internal diagnosis information to status groups.

Further details can be found in the the section "Operation / Diagnostic information and status messages" in the standard documentation of the transmitter.

The status signal (severity) of some status groups can be configured.

Register Address	Type	Qty.	Name	Description	Values	Display Fct. No.	Fn.
8200 (0x2008)	UINT	1	Status Group - Process: Signal Low	NE 107 severity of signal status group "Process: Signal Low".	0 = Off 1 = Information 2 = Off 4 = Maintenance Required 8 = Off 16 = Function Check 32 = Out of Spec. (default) 64 = Application Failure 128 = Failure	C6.6.1	①
8201 (0x2009)	UINT	1	Status Group - Process: Signal Search	NE 107 severity of signal status group "Process: Signal Search".	0 = Off 1 = Information 2 = Off 4 = Maintenance Required 8 = Off 16 = Function Check 32 = Out of Specification 64 = Application Failure 128 = Failure (default)	C6.6.2	①

Register Address	Type	Qty.	Name	Description	Values	Display Fct. No.	Fn.
8202 (0x200A)	UINT	1	Status Group - Process: Two Phase Signal	NE 107 severity of signal status group "Process: Two Phase Flow".	0 = Off 1 = Information 2 = Off 4 = Maintenance Required 8 = Off 16 = Function Check 32 = Out of Spec. (default) 64 = Application Failure 128 = Failure	C6.6.3	①
8203 (0x200B)	UINT	1	Status Group - Process: System Control	NE 107 severity of signal status group "Process: System Control".	0 = Off 1 = Information (default) 2 = Off 4 = Maintenance Required 8 = Off 16 = Function Check 32 = Out of Specification 64 = Application Failure 128 = Failure	C6.6.4	①
8204 (0x200C)	UINT	1	Status Group - Configuration: Totaliser	NE 107 severity of signal status group "Configuration: Totaliser".	0 = Off 1 = Information 2 = Off 4 = Maintenance Required 8 = Off 16 = Function Check 32 = Out of Spec. (default) 64 = Application Failure 128 = Failure	C6.6.5	①
8205 (0x200D)	UINT	1	Status Group - Electronics: Power Failure	NE 107 severity of signal status group "Electronics: Power Failure".	0 = Off 1 = Information (default) 2 = Off 4 = Maintenance Required 8 = Off 16 = Function Check 32 = Out of Specification 64 = Application Failure 128 = Failure	C6.6.6	①
8206 (0x200E)	UINT	1	Status Group - Electronics: IO Connection	NE 107 severity of signal status group "Electronics: IO connection".	0 = Off 1 = Information 2 = Off 4 = Maintenance Required 8 = Off 16 = Function Check 32 = Out of Spec. (default) 64 = Application	C6.6.7	①

Table 7-17: Modbus data - Configuration of NE 107 status groups

① Execute the "Apply Changes" command to apply and to save changes (refer to "Device Control Command").

7.10 Modbus

7.10.1 Communication settings

The basic communication parameters of the Modbus interface can be changed via display or Modbus itself. For the description of some of the timing relevant settings refer to *RTU frame format* on page 18.



NOTICE!

Changes will be applied after the "Apply Changes" command and the interface re-initialises to the new parameters.

For modifications of Baud Rate and Frame Format, the Modbus master needs to update its settings accordingly!

Register Address	Type	Qty.	Name	Description	Values	Display Fct. No.	Fn.
132 (0x0084)	UINT	1	Slave Address	Address of the Modbus interface.	Default: 1 Range: 1...255	C4.1	① ②
133 (0x0085)	UINT	1	Baud Rate	Baud rate of the Modbus interface.	0 = 1200 1 = 2400 3 = 4800 4 = 9600 6 = 19200 (default) 9 = 38400 11 = 57600 12 = 115200	C4.2	①
134 (0x0086)	UINT	1	Frame Format	Format of the Modbus frame (number of data bits, parity, number of stop bits).	0 = 8 Data Bits, "Even" Parity, 1 Stop Bit (default) 1 = 8 Data Bits, "Odd" Parity, 1 Stop Bit 2 = 8 Data Bits, no Parity, 2 Stop Bits 3 = 8 Data Bits, no Parity, 1 Stop Bit	C4.3	①
135 (0x0087)	UINT	1	Transmission Delay	Additional delay before sending out a Modbus response.	Default: 0 Range: 0...50 Fix unit: [ms]	C4.5	①
136 (0x0088)	UINT	1	Transmission Mode	Modbus serial transmission mode.	0 = Fix timings according to Modbus specification (default) 1 = Timing depends on Baud Rate (also above 19200 baud)	C4.4	①
137 (0x0089)	UINT	1	Broadcast Support	Enable or disable support of broadcast telegrams.	0 = Disable Broadcast Support (broadcast telegrams are ignored) 1 = Enable Broadcast Support (default)	C4.6	①

Table 7-18: Modbus data - Modbus - Communication settings

① Execute the "Apply Changes" command to apply and to save changes (refer to "Device Control Command").

② Addresses from 1 to 247 are officially permitted. Address 0 is used for broadcast telegrams.

7.10.2 Endianness / Byte order

The endianness (byte order) specifies in which order the data is mapped onto Modbus registers (for details refer to *Data representation* on page 20). There are four data items that can be read in order to test for the correct endianness selection.

Register Address	Type	Qty.	Name	Description	Values	Display Fct. No.	Fn.
108 (0x006C)	UINT	1	Endianness of strings	Select byte order for data type STRING.	Byte Order 0 = "normal" (default) 1 = "swapped"	C4.7	①
109 (0x006D)	UINT	1	Endianness of 2-byte data	Select byte order for 2-byte data types INT, UINT, WORD.	Byte Order 0 = "AB" (default) 1 = "BA"	C4.8	①
110 (0x006E)	UINT	1	Endianness of 4-byte data	Select byte order for 4-byte data types DINT, DWORD, REAL, UDINT.	Byte Order 0 = "ABCD" (default) 1 = "DCBA" 2 = "CDAB" 3 = "BADC"	C4.9	①
111 (0x006F)	UINT	1	Endianness of 8-byte data	Select byte order for 8-byte data types LINT, LWORD, LREAL, ULINT.	Byte Order 0 = "ABCDEFGH" (default) 1 = "HGFEDCBA" 2 = "GHEFCDAB" 3 = "BADCFEHG"	C4.10	①
112 (0x0070)	STRING	3	Example string data	Constant fixed character string to test selected endianness for data types of type STRING (see register 108). (read-only)	"Hello!"	-	-
115 (0x0073)	UINT	1	Example 2-byte data	Constant fixed value to test selected endianness for 2-byte data types INT, UINT, WORD (see register 109). (read-only)	Default: 0x9C40	-	②
116 (0x0074)	UDINT	2	Example 4-byte data	Constant fixed value to test selected endianness for 4-byte data types DINT, DWORD, REAL, UDINT (see register 110). (read-only)	Default: 0xC7F12059	-	③

Register Address	Type	Qty.	Name	Description	Values	Display Fct. No.	Fn.
118 (0x0076)	ULINT	4	Example 8-byte data	Constant fixed value to test selected endianness for 8-byte data types LINT, LWORD, LREAL, ULINT (see register 111). (read-only)	Default: 0xC0FE240C9FBE76C9	-	④

Table 7-19: Modbus data - Modbus - Endianness / Byte order

① Execute the "Apply Changes" command to apply and to save changes (refer to "Device Control Command").

② If the endianness on the Modbus master system matches, one of the following values should be displayed depending on the data type selected:

INT = -25 536

UINT = 40 000

WORD = 0x 9C 40 (or binary representation)

③ If the endianness on the Modbus master system matches, one of the following values should be displayed depending on the data type selected:

DINT = - 940 498 855 ≈ 940 million

DWORD = 0x C7 F1 20 59 REAL = - 123 456.7

UDINT = 3 354 468 441 ≈ 3.35 billion

④ If the endianness on the Modbus master system matches, one of the following values should be displayed depending on the data type selected:

LINT = - 4 540 151 737 704 614 199 ≈ - 4.5 quintillion

LWORD = 0x C0 FE 24 0C 9F BE 76 C9

LREAL = - 123 456.789

ULINT = 13 906 592 336 004 937 417 ≈ 14 quintillion

7.10.3 Improved exception handling

The improved exception handling allows to get further details on a Modbus exception. There are three data items available that are intended to be read right after the transmitter returned a Modbus exception code 04 SERVER DEVICE FAILURE.

For further information refer to *Modbus Exceptions* on page 31.

Register Address	Type	Qty.	Name	Description	Values	Display Fct. No.	Fn.
13 (0x000D)	UINT	1	Modbus IEH - Error Code	The "Error Code" contains the result of the previous transaction. (read-only)	Default: 0 <Error Code> 0 = No Error 1 = Undefined Error 2 = Access Authorization Error 3 = Data Access Error 4 = Timing Error 5 = Procedure Error	-	-
14 (0x000E)	UINT	1	Modbus IEH - Error Sub-Code	The "Error Sub-Code" contains further information about the error condition. Value depends on "Error Code". (read-only)	Default: 0 <Error Code = 2> 0 = Undefined Sub-Code 1 = Read operation (temporarily) forbidden 2 = Write operation (temporarily) forbidden 3 = Read-only data item that can never be written 4 = Write-only data item that can never be read 5 = Invalid password 6 = Login attempts exceeded 7 = Hardware 'Write Lock' enabled <Error Code = 3> 0 = Undefined Sub-Code 1 = Over range error 2 = Under range error 3 = Invalid value for an enumeration 4 = Invalid text string 5 = Invalid condition <Error Code = 4> 0 = Undefined Subcode 1 = Internal timeout 2 = Device busy <Error Code = 5> 0 = Undefined Subcode 1 = Invalid state change 2 = Preconditions for the requested procedure not fulfilled	-	-
15 (0x000F)	UINT	1	Modbus IEH - Erroneous Data Item	The "Erroneous Data" Item contains the Modbus register start address of the (first) erroneous data item. (read-only)	Default: 0	-	-

Table 7-20: Modbus data - Modbus - Improved exception handling

7.10.4 Custom register assignment

For the description of the custom register assignment feature refer to *Custom Register Assignment* on page 33.

Register Address	Type	Qty.	Name	Description	Values	Display Fct. No.	Fn.
0 (0x0000)	UINT	1	Gap	A virtual data item used by Customer Register Assignment to fill/create gaps between "normal" data. (read-only)	Default: 0	-	-
999 (0x03E7)	UINT	1	Custom Register Mapping Status	Contains Modbus register address of first Custom Register Mapping item with invalid configuration (i.e. unknown register reference). Value = 0: Configuration is valid. (read-only)	-	-	-
1000 (0x03E8)	-	500	Custom Register List	Allocation and size depends on the Custom Register Mapping.	Default: 0	-	-
1500 (0x05DC)	UINT	1	Custom Register Mapping of Item 1	Reference to data item that constitutes the 1st item of the Custom Register List.	Default: 0	-	①
1501 (0x05DD)	UINT	1	Custom Register Mapping of Item 2	Reference to data item that constitutes the 2nd entry of the Custom Register List.	Default: 0	-	①
1502 (0x05DE)	UINT	1	Custom Register Mapping of Item 3	Reference to data item that constitutes the 3rd entry of the Custom Register List.	Default: 0	-	①
1503 (0x05DF)	UINT	1	Custom Register Mapping of Item 4	Reference to data item that constitutes the 4th entry of the Custom Register List.	Default: 0	-	①
1504 (0x05E0)	UINT	1	Custom Register Mapping of Item 5	Reference to data item that constitutes the 5th entry of the Custom Register List.	Default: 0	-	①
1505 (0x05E1)	UINT	1	Custom Register Mapping of Item 6	Reference to data item that constitutes the 6th entry of the Custom Register List.	Default: 0	-	①
1506 (0x05E2)	UINT	1	Custom Register Mapping of Item 7	Reference to data item that constitutes the 7th entry of the Custom Register List.	Default: 0	-	①

Register Address	Type	Qty.	Name	Description	Values	Display Fct. No.	Fn.
1507 (0x05E3)	UINT	1	Custom Register Mapping of Item 8	Reference to data item that constitutes the 8th entry of the Custom Register List.	Default: 0	-	①
1508 (0x05E4)	UINT	1	Custom Register Mapping of Item 9	Reference to data item that constitutes the 9th entry of the Custom Register List.	Default: 0	-	①
1509 (0x05E5)	UINT	1	Custom Register Mapping of Item 10	Reference to data item that constitutes the 10th entry of the Custom Register List.	Default: 0	-	①
1510 (0x05E6)	UINT	1	Custom Register Mapping of Item 11	Reference to data item that constitutes the 11th entry of the Custom Register List.	Default: 0	-	①
1511 (0x05E7)	UINT	1	Custom Register Mapping of Item 12	Reference to data item that constitutes the 12th entry of the Custom Register List.	Default: 0	-	①
1512 (0x05E8)	UINT	1	Custom Register Mapping of Item 13	Reference to data item that constitutes the 13th entry of the Custom Register List.	Default: 0	-	①
1513 (0x05E9)	UINT	1	Custom Register Mapping of Item 14	Reference to data item that constitutes the 14th entry of the Custom Register List.	Default: 0	-	①
1514 (0x05EA)	UINT	1	Custom Register Mapping of Item 15	Reference to data item that constitutes the 15th entry of the Custom Register List.	Default: 0	-	①
1515 (0x05EB)	UINT	1	Custom Register Mapping of Item 16	Reference to data item that constitutes the 16th entry of the Custom Register List.	Default: 0	-	①
1516 (0x05EC)	UINT	1	Custom Register Mapping of Item 17	Reference to data item that constitutes the 17th entry of the Custom Register List.	Default: 0	-	①
1517 (0x05ED)	UINT	1	Custom Register Mapping of Item 18	Reference to data item that constitutes the 18th entry of the Custom Register List.	Default: 0	-	①
1518 (0x05EE)	UINT	1	Custom Register Mapping of Item 19	Reference to data item that constitutes the 19th entry of the Custom Register List.	Default: 0	-	①
1519 (0x05EF)	UINT	1	Custom Register Mapping of Item 20	Reference to data item that constitutes the 20th entry of the Custom Register List.	Default: 0	-	①

Register Address	Type	Qty.	Name	Description	Values	Display Fct. No.	Fn.
1520 (0x05F0)	UINT	1	Custom Register Mapping of Item 21	Reference to data item that constitutes the 21st entry of the Custom Register List.	Default: 0	-	①
1521 (0x05F1)	UINT	1	Custom Register Mapping of Item 22	Reference to data item that constitutes the 22nd entry of the Custom Register List.	Default: 0	-	①
1522 (0x05F2)	UINT	1	Custom Register Mapping of Item 23	Reference to data item that constitutes the 23rd entry of the Custom Register List.	Default: 0	-	①
1523 (0x05F3)	UINT	1	Custom Register Mapping of Item 24	Reference to data item that constitutes the 24th entry of the Custom Register List.	Default: 0	-	①
1524 (0x05F4)	UINT	1	Custom Register Mapping of Item 25	Reference to data item that constitutes the 25th entry of the Custom Register List.	Default: 0	-	①
1525 (0x05F5)	UINT	1	Custom Register Mapping of Item 26	Reference to data item that constitutes the 26th entry of the Custom Register List.	Default: 0	-	①
1526 (0x05F6)	UINT	1	Custom Register Mapping of Item 27	Reference to data item that constitutes the 27th entry of the Custom Register List.	Default: 0	-	①
1527 (0x05F7)	UINT	1	Custom Register Mapping of Item 28	Reference to data item that constitutes the 28th entry of the Custom Register List.	Default: 0	-	①
1528 (0x05F8)	UINT	1	Custom Register Mapping of Item 29	Reference to data item that constitutes the 29th entry of the Custom Register List.	Default: 0	-	①
1529 (0x05F9)	UINT	1	Custom Register Mapping of Item 30	Reference to data item that constitutes the 30th entry of the Custom Register List.	Default: 0	-	①
1530 (0x05FA)	UINT	1	Custom Register Mapping of Item 31	Reference to data item that constitutes the 31st entry of the Custom Register List.	Default: 0	-	①
1531 (0x05FB)	UINT	1	Custom Register Mapping of Item 32	Reference to data item that constitutes the 32nd entry of the Custom Register List.	Default: 0	-	①

Table 7-21: Modbus data - Modbus - Custom register assignment

① Execute the "Apply Changes" command to apply and to save changes (refer to "Device Control Command").

7.10.5 Serial diagnostic counters

Some of the functionalities of Modbus Function Code 8 "Diagnostics" are also available via Modbus register access (for details refer to *Modbus Serial Diagnostics* on page 30).

Register Address	Type	Qty.	Name	Description	Values	Display Fct. No.	Fn.
122 (0x007A)	UINT	1	Clear Counters and Diagnostic Register	Writing a "1" clears all of the Modbus diagnostic counters. Reading this data item returns "0".	Default: 0x0000 0 = Not used / no action 1 = Perform action	-	①
123 (0x007B)	UINT	1	Clear Overrun Counter and Flag	Writing a "1" clears the Modbus overrun error counter. Reading this data item returns "0".	Default: 0x0000 0 = Not used / no action 1 = Perform action	-	①
124 (0x007C)	UINT	1	Bus Message Count	The number of messages detected on Modbus since power-on or last reset. In case of overflow, the counter proceeds with "1". (read-only)	Default: 0x0000	-	①
125 (0x007D)	UINT	1	Bus Communication Error Count	The number of corrupted messages (i.e. checksum error) detected on Modbus since power-on or last reset. In case of overflow, the counter proceeds with "1". (read-only)	Default: 0x0000	-	①
126 (0x007E)	UINT	1	Bus Exception Error Count	The number of exceptions responses returned by the device since power-on or last reset. In case of overflow, the counter proceeds with "1". (read-only)	Default: 0x0000	-	①
127 (0x007F)	UINT	1	Server Message Count	The number of messages addressed to the device since power-on or last reset. In case of overflow, the counter proceeds with "1". (read-only)	Default: 0x0000	-	①
128 (0x0080)	UINT	1	Server No Response Count	The number of messages detected by the device for which no response was returned since power-on or last reset. In case of overflow, the counter proceeds with "1". (read-only)	Default: 0x0000	-	①

Register Address	Type	Qty.	Name	Description	Values	Display Fct. No.	Fn.
129 (0x0081)	UINT	1	Bus Character Overrun Count	The number of messages with a character overrun error since power-on or last reset. In case of overflow, the counter proceeds with "1". (read-only)	Default: 0x0000	-	①
130 (0x0082)	UINT	1	Server Busy Count	The number of messages for which the device returned a BUSY exception since power-on or last reset. In case of overflow, the counter proceeds with "1". (read-only)	Default: 0x0000	-	①
131 (0x0083)	UINT	1	Server NAK Count	The number of messages for which the device returned a NAK exception response since power-on or last reset. In case of overflow, the counter proceeds with "1". (read-only)	Default: 0x0000	-	①

Table 7-22: Modbus data - Modbus - Serial diagnostic

① The data can also be accessed using Modbus Function Code 8 "Diagnostics".

8.1 Modbus map

8.1.1 Input Registers / Holding Registers

The following table is a list of all data items available via register access sorted by ascending start addresses.

Gaps are being highlighted by a grey line to indicate which data is available on contiguous registers.

- RO = read-only
- RW = read-write

Register Address	Qty.	Name	Type	Access
0 (0x0000)	1	Gap	UINT	RO
1 (0x0001)	1	Device Control Command	UINT	RW
2 (0x0002)	1	Device Status	WORD	RO
3 (0x0003)	1	Data Status	WORD	RO
4 (0x0004)	1	Configuration Change Counter	UINT	RO
5 (0x0005)	2	Operating Time	UDINT	RO
7 (0x0007)	2	Uptime Counter	UDINT	RO
13 (0x000D)	1	Modbus IEH - Error Code	UINT	RO
14 (0x000E)	1	Modbus IEH - Error Sub-Code	UINT	RO
15 (0x000F)	1	Modbus IEH - Erroneous Data Item	UINT	RO
16 (0x0010)	4	Interface Revision (array)	UINT	RO
20 (0x0014)	4	Electronic Revision (array)	UINT	RO
24 (0x0018)	6	Interface Revision (string) / MajorMinorRevision	STRING	RO
30 (0x001E)	6	Electronic Revision (string)	STRING	RO
36 (0x0024)	12	Vendor Name	STRING	RO
48 (0x0030)	4	Product Code	STRING	RO
52 (0x0034)	16	VendorUrl	STRING	RO
68 (0x0044)	8	Product Name	STRING	RO
76 (0x004C)	16	Model Name	STRING	RO
92 (0x005C)	16	Device Tag (User Application Name)	STRING	RW
108 (0x006C)	1	Endianness of strings	UINT	RW
109 (0x006D)	1	Endianness of 2-byte data	UINT	RW
110 (0x006E)	1	Endianness of 4-byte data	UINT	RW
111 (0x006F)	1	Endianness of 8-byte data	UINT	RW
112 (0x0070)	3	Example string data	STRING	RO
115 (0x0073)	1	Example 2-byte data	UINT	RO
116 (0x0074)	2	Example 4-byte data	UDINT	RO

Register Address	Qty.	Name	Type	Access
118 (0x0076)	4	Example 8-byte data	ULINT	RO
122 (0x007A)	1	Clear Counters and Diagnostic Register	UINT	RW
123 (0x007B)	1	Clear Overrun Counter and Flag	UINT	RW
124 (0x007C)	1	Bus Message Count	UINT	RO
125 (0x007D)	1	Bus Communication Error Count	UINT	RO
126 (0x007E)	1	Bus Exception Error Count	UINT	RO
127 (0x007F)	1	Server Message Count	UINT	RO
128 (0x0080)	1	Server No Response Count	UINT	RO
129 (0x0081)	1	Bus Character Overrun Count	UINT	RO
130 (0x0082)	1	Server Busy Count	UINT	RO
131 (0x0083)	1	Server NAK Count	UINT	RO
132 (0x0084)	1	Slave Address	UINT	RW
133 (0x0085)	1	Baud Rate	UINT	RW
134 (0x0086)	1	Frame Format	UINT	RW
135 (0x0087)	1	Transmission Delay	UINT	RW
136 (0x0088)	1	Transmission Mode	UINT	RW
137 (0x0089)	1	Broadcast Support	UINT	RW
247 (0x00F7)	2	Mass Flow - Value	REAL	RO
249 (0x00F9)	2	Density - Value	REAL	RO
251 (0x00FB)	2	Temperature - Value	REAL	RO
253 (0x00FD)	2	Volume Flow - Value	REAL	RO
259 (0x0103)	2	Totaliser 1 - Value (REAL)	REAL	RO
261 (0x0105)	2	Totaliser 2 - Value (REAL)	REAL	RO
999 (0x03E7)	1	Custom Register Mapping Status	UINT	RO
1000 (0x03E8)	500	Custom Register List	-	RW
1500 (0x05DC)	1	Custom Register Mapping of Item 1	UINT	RW
1501 (0x05DD)	1	Custom Register Mapping of Item 2	UINT	RW
1502 (0x05DE)	1	Custom Register Mapping of Item 3	UINT	RW
1503 (0x05DF)	1	Custom Register Mapping of Item 4	UINT	RW
1504 (0x05E0)	1	Custom Register Mapping of Item 5	UINT	RW
1505 (0x05E1)	1	Custom Register Mapping of Item 6	UINT	RW
1506 (0x05E2)	1	Custom Register Mapping of Item 7	UINT	RW
1507 (0x05E3)	1	Custom Register Mapping of Item 8	UINT	RW
1508 (0x05E4)	1	Custom Register Mapping of Item 9	UINT	RW
1509 (0x05E5)	1	Custom Register Mapping of Item 10	UINT	RW
1510 (0x05E6)	1	Custom Register Mapping of Item 11	UINT	RW

Register Address	Qty.	Name	Type	Access
1511 (0x05E7)	1	Custom Register Mapping of Item 12	UINT	RW
1512 (0x05E8)	1	Custom Register Mapping of Item 13	UINT	RW
1513 (0x05E9)	1	Custom Register Mapping of Item 14	UINT	RW
1514 (0x05EA)	1	Custom Register Mapping of Item 15	UINT	RW
1515 (0x05EB)	1	Custom Register Mapping of Item 16	UINT	RW
1516 (0x05EC)	1	Custom Register Mapping of Item 17	UINT	RW
1517 (0x05ED)	1	Custom Register Mapping of Item 18	UINT	RW
1518 (0x05EE)	1	Custom Register Mapping of Item 19	UINT	RW
1519 (0x05EF)	1	Custom Register Mapping of Item 20	UINT	RW
1520 (0x05F0)	1	Custom Register Mapping of Item 21	UINT	RW
1521 (0x05F1)	1	Custom Register Mapping of Item 22	UINT	RW
1522 (0x05F2)	1	Custom Register Mapping of Item 23	UINT	RW
1523 (0x05F3)	1	Custom Register Mapping of Item 24	UINT	RW
1524 (0x05F4)	1	Custom Register Mapping of Item 25	UINT	RW
1525 (0x05F5)	1	Custom Register Mapping of Item 26	UINT	RW
1526 (0x05F6)	1	Custom Register Mapping of Item 27	UINT	RW
1527 (0x05F7)	1	Custom Register Mapping of Item 28	UINT	RW
1528 (0x05F8)	1	Custom Register Mapping of Item 29	UINT	RW
1529 (0x05F9)	1	Custom Register Mapping of Item 30	UINT	RW
1530 (0x05FA)	1	Custom Register Mapping of Item 31	UINT	RW
1531 (0x05FB)	1	Custom Register Mapping of Item 32	UINT	RW
2000 (0x07D0)	1	Sensor Diagnostics	WORD	RO
2001 (0x07D1)	1	Velocity - Status	WORD	RO
2002 (0x07D2)	2	Velocity - Value	REAL	RO
2004 (0x07D4)	1	Volume Flow - Status	WORD	RO
2005 (0x07D5)	2	Volume Flow - Value	REAL	RO
2007 (0x07D7)	1	Mass Flow - Status	WORD	RO
2008 (0x07D8)	2	Mass Flow - Value	REAL	RO
2010 (0x07DA)	1	Temperature - Status	WORD	RO
2011 (0x07DB)	2	Temperature - Value	REAL	RO
2013 (0x07DD)	1	Density - Status	WORD	RO
2014 (0x07DE)	2	Density - Value	REAL	RO
2016 (0x07E0)	1	Diagnosis 1 - Status	WORD	RO
2017 (0x07E1)	2	Diagnosis 1 - Value	REAL	RO
2019 (0x07E3)	1	Diagnosis 2 - Status	WORD	RO
2020 (0x07E4)	2	Diagnosis 2 - Value	REAL	RO
2022 (0x07E6)	1	Concentration 1 - Status	WORD	RO
2023 (0x07E7)	2	Concentration 1 - Value	REAL	RO

Register Address	Qty.	Name	Type	Access
2025 (0x07E9)	1	Concentration 2 - Status	WORD	RO
2026 (0x07EA)	2	Concentration 2 - Value	REAL	RO
2028 (0x07EC)	1	Concentration 1 Flow - Status	WORD	RO
2029 (0x07ED)	2	Concentration 1 Flow - Value	REAL	RO
2031 (0x07EF)	1	Concentration 2 Flow - Status	WORD	RO
2032 (0x07F0)	2	Concentration 2 Flow - Value	REAL	RO
2034 (0x07F2)	2	Drive Level	REAL	RO
2036 (0x07F4)	2	Sensor A Level	REAL	RO
2038 (0x07F6)	2	Sensor B Level	REAL	RO
2040 (0x07F8)	2	Strain 1	REAL	RO
2042 (0x07FA)	2	Strain 2	REAL	RO
2044 (0x07FC)	2	Tube Frequency	REAL	RO
2046 (0x07FE)	2	Two Phase Signal	REAL	RO
2048 (0x0800)	2	Sensor Electronics Temperature	REAL	RO
2100 (0x0834)	1	Totaliser 1 - Status	WORD	RO
2101 (0x0835)	2	Totaliser 1 - Value (REAL)	REAL	RO
2103 (0x0837)	1	Totaliser 2 - Status	WORD	RO
2104 (0x0838)	2	Totaliser 2 - Value (REAL)	REAL	RO
2106 (0x083A)	1	Totaliser 3 - Status	WORD	RO
2107 (0x083B)	2	Totaliser 3 - Value (REAL)	REAL	RO
2200 (0x0898)	1	Totaliser 1 - Status	WORD	RO
2201 (0x0899)	4	Totaliser 1 - Value (LREAL)	LREAL	RO
2205 (0x089D)	1	Totaliser 2 - Status	WORD	RO
2206 (0x089E)	4	Totaliser 2 - Value (LREAL)	LREAL	RO
2210 (0x08A2)	1	Totaliser 3 - Status	WORD	RO
2211 (0x08A3)	4	Totaliser 3 - Value (LREAL)	LREAL	RO
3010 (0x0BC2)	1	Totaliser 1 - Control	UINT	RW
3011 (0x0BC3)	2	Totaliser 1 - Set Value	REAL	RW
3020 (0x0BCC)	1	Totaliser 2 - Control	UINT	RW
3021 (0x0BCD)	2	Totaliser 2 - Set Value	REAL	RW
3030 (0x0BD6)	1	Totaliser 3 - Control	UINT	RW
3031 (0x0BD7)	2	Totaliser 3 - Set Value	REAL	RW
3100 (0x0C1C)	1	Totaliser 1 - Measurement	UINT	RW

Register Address	Qty.	Name	Type	Access
3101 (0x0C1D)	1	Totaliser 1 - Function	UINT	RW
3102 (0x0C1E)	2	Totaliser 1 - Damping	REAL	RW
3104 (0x0C20)	2	Totaliser 1 - Low Flow Cut-off - Threshold	REAL	RW
3106 (0x0C22)	2	Totaliser 1 - Low Flow Cut-off - Hysteresis	REAL	RW
3200 (0x0C80)	1	Totaliser 2 - Measurement	UINT	RW
3201 (0x0C81)	1	Totaliser 2 - Function	UINT	RW
3202 (0x0C82)	2	Totaliser 2 - Damping	REAL	RW
3204 (0x0C84)	2	Totaliser 2 - Low Flow Cut-off - Threshold	REAL	RW
3206 (0x0C86)	2	Totaliser 2 - Low Flow Cut-off - Hysteresis	REAL	RW
3300 (0x0CE4)	1	Totaliser 3 - Measurement	UINT	RW
3301 (0x0CE5)	1	Totaliser 3 - Function	UINT	RW
3302 (0x0CE6)	2	Totaliser 3 - Damping	REAL	RW
3304 (0x0CE8)	2	Totaliser 3 - Low Flow Cut-off - Threshold	REAL	RW
3306 (0x0CEA)	2	Totaliser 3 - Low Flow Cut-off - Hysteresis	REAL	RW
4000 (0x0FA0)	1	Flow Direction	UINT	RW
4001 (0x0FA1)	2	Process Noise Damping	REAL	RW
4003 (0x0FA3)	2	Low Flow Cut-off	REAL	RW
4005 (0x0FA5)	2	Pipe Diameter	REAL	RW
4007 (0x0FA7)	2	Pressure Suppression - Low Flow Cut-off	REAL	RW
4009 (0x0FA9)	2	Pressure Suppression - Time	REAL	RW
4011 (0x0FAB)	2	Zero Additional Offset	REAL	RW
4013 (0x0FAD)	2	Flow Correction	REAL	RW
4015 (0x0FAF)	1	Density Mode	UINT	RW
4016 (0x0FB0)	2	Fixed Density Value	REAL	RW
4018 (0x0FB2)	2	Referred Density Temperature	REAL	RW
4020 (0x0FB4)	2	Referred Density Slope	REAL	RW
4022 (0x0FB6)	2	Standard Density Temperature	REAL	RW
4024 (0x0FB8)	2	Standard Density k0	REAL	RW
4026 (0x0FBA)	2	Standard Density k1	REAL	RW
4028 (0x0FBC)	2	Standard Density k2	REAL	RW
4030 (0x0FBE)	1	System Control - Function	UINT	RW
4031 (0x0FBF)	1	System Control - Variable	UINT	RW
4032 (0x0FC0)	2	System Control - Min Density	REAL	RW
4034 (0x0FC2)	2	System Control - Max Density	REAL	RW
4036 (0x0FC4)	2	System Control - Min Temperature	REAL	RW
4038 (0x0FC6)	2	System Control - Max Temperature	REAL	RW

Register Address	Qty.	Name	Type	Access
4050 (0x0FD2)	1	Concentration 1 - Function	UINT	RW
4051 (0x0FD3)	2	Concentration 1 - Offset	REAL	RW
4053 (0x0FD5)	1	Concentration 1 - Product	UINT	RW
4054 (0x0FD6)	1	Concentration 2 - Function	UINT	RW
4055 (0x0FD7)	2	Concentration 2 - Offset	REAL	RW
4057 (0x0FD9)	1	Concentration 2 - Product	UINT	RW
4058 (0x0FDA)	1	Concentration Data Select	UINT	RW
4059 (0x0FDB)	1	Concentration Data 1 - Coefficient CCF01	UINT	RW
4060 (0x0FDC)	2	Concentration Data 1 - Coefficient CCF02	REAL	RW
4062 (0x0FDE)	2	Concentration Data 1 - Coefficient CCF03	REAL	RW
4064 (0x0FE0)	2	Concentration Data 1 - Coefficient CCF04	REAL	RW
4066 (0x0FE2)	1	Concentration Data 1 - Coefficient CCF05	UINT	RW
4067 (0x0FE3)	2	Concentration Data 1 - Coefficient CCF06	REAL	RW
4069 (0x0FE5)	2	Concentration Data 1 - Coefficient CCF07	REAL	RW
4071 (0x0FE7)	2	Concentration Data 1 - Coefficient CCF08	REAL	RW
4073 (0x0FE9)	2	Concentration Data 1 - Coefficient CCF09	REAL	RW
4075 (0x0FEB)	2	Concentration Data 1 - Coefficient CCF10	REAL	RW
4077 (0x0FED)	2	Concentration Data 1 - Coefficient CCF11	REAL	RW
4079 (0x0FEF)	2	Concentration Data 1 - Coefficient CCF12	REAL	RW
4081 (0x0FF1)	1	Concentration Data 2 - Coefficient CCF01	UINT	RW
4082 (0x0FF2)	2	Concentration Data 2 - Coefficient CCF02	REAL	RW
4084 (0x0FF4)	2	Concentration Data 2 - Coefficient CCF03	REAL	RW
4086 (0x0FF6)	2	Concentration Data 2 - Coefficient CCF04	REAL	RW
4088 (0x0FF8)	1	Concentration Data 2 - Coefficient CCF05	UINT	RW
4089 (0x0FF9)	2	Concentration Data 2 - Coefficient CCF06	REAL	RW
4091 (0x0FFB)	2	Concentration Data 2 - Coefficient CCF07	REAL	RW
4093 (0x0FFD)	2	Concentration Data 2 - Coefficient CCF08	REAL	RW
4095 (0x0FFF)	2	Concentration Data 2 - Coefficient CCF09	REAL	RW
4097 (0x1001)	2	Concentration Data 2 - Coefficient CCF10	REAL	RW
4099 (0x1003)	2	Concentration Data 2 - Coefficient CCF11	REAL	RW
4101 (0x1005)	2	Concentration Data 2 - Coefficient CCF12	REAL	RW
4200 (0x1068)	1	Start Zero Calibration	UINT	RW
4300 (0x10CC)	1	Operation Mode	UINT	RW
4301 (0x10CD)	2	Two Phase Threshold	REAL	RW
4303 (0x10CF)	1	Selector for "Diagnosis 1 - Value"	UINT	RW
4304 (0x10D0)	1	Selector for "Diagnosis 2 - Value"	UINT	RW

Register Address	Qty.	Name	Type	Access
8000 (0x1F40)	1	Volume Flow - Unit	UINT	RW
8001 (0x1F41)	1	Mass Flow - Unit	UINT	RW
8002 (0x1F42)	1	Density - Unit	UINT	RW
8003 (0x1F43)	1	Volume - Unit	UINT	RW
8004 (0x1F44)	1	Mass - Unit	UINT	RW
8005 (0x1F45)	1	Velocity - Unit	UINT	RW
8006 (0x1F46)	1	Temperature - Unit	UINT	RW
8100 (0x1FA4)	2	Volume Flow - Conversion Factor	REAL	RW
8102 (0x1FA6)	2	Mass Flow - Conversion Factor	REAL	RW
8104 (0x1FA8)	2	Density - Conversion Factor	REAL	RW
8106 (0x1FAA)	2	Volume - Conversion Factor	REAL	RW
8108 (0x1FAC)	2	Mass - Conversion Factor	REAL	RW
8200 (0x2008)	1	Status Group - Process: Signal Low	UINT	RW
8201 (0x2009)	1	Status Group - Process: Signal Search	UINT	RW
8202 (0x200A)	1	Status Group - Process: Two Phase Signal	UINT	RW
8203 (0x200B)	1	Status Group - Process: System Control	UINT	RW
8204 (0x200C)	1	Status Group - Configuration: Totaliser	UINT	RW
8205 (0x200D)	1	Status Group - Electronics: Power Failure	UINT	RW
8206 (0x200E)	1	Status Group - Electronics: IO Connection	UINT	RW
8300 (0x206C)	1	Operator Password	UINT	RW
30000 (0x7530)	2	Velocity - Value	REAL	RO
30002 (0x7532)	2	Volume Flow - Value	REAL	RO
30004 (0x7534)	2	Mass Flow - Value	REAL	RO
30006 (0x7536)	2	Temperature - Value	REAL	RO
30008 (0x7538)	2	Density - Value	REAL	RO
30010 (0x753A)	2	Concentration 1 - Value	REAL	RO
30012 (0x753C)	2	Concentration 2 - Value	REAL	RO
30014 (0x753E)	2	Concentration 1 Flow - Value	REAL	RO
30016 (0x7540)	2	Concentration 2 Flow - Value	REAL	RO
30500 (0x7724)	1	Velocity - Status	WORD	RO
30501 (0x7725)	1	Volume Flow - Status	WORD	RO
30502 (0x7726)	1	Mass Flow - Status	WORD	RO
30503 (0x7727)	1	Temperature - Status	WORD	RO

Register Address	Qty.	Name	Type	Access
30504 (0x7728)	1	Density - Status	WORD	RO
30505 (0x7729)	1	Concentration 1 - Status	WORD	RO
30506 (0x772A)	1	Concentration 2 - Status	WORD	RO
30507 (0x772B)	1	Concentration 1 Flow - Status	WORD	RO
30508 (0x772C)	1	Concentration 2 Flow - Status	WORD	RO
31000 (0x7918)	2	Drive Level	REAL	RO
31002 (0x791A)	2	Sensor A Level	REAL	RO
31004 (0x791C)	2	Sensor B Level	REAL	RO
31006 (0x791E)	2	Strain 1	REAL	RO
31008 (0x7920)	2	Strain 2	REAL	RO
31010 (0x7922)	2	Tube Frequency	REAL	RO
31012 (0x7924)	2	Two Phase Signal	REAL	RO
31014 (0x7926)	2	Sensor Electronics Temperature	REAL	RO
32000 (0x7D00)	4	Totaliser 1 - Value (LREAL)	LREAL	RO
32004 (0x7D04)	4	Totaliser 2 - Value (LREAL)	LREAL	RO
32008 (0x7D08)	4	Totaliser 3 - Value (LREAL)	LREAL	RO
32100 (0x7D64)	4	Totaliser 1 - Value (REAL)	REAL	RO
32102 (0x7D66)	4	Totaliser 2 - Value (REAL)	REAL	RO
32104 (0x7D68)	4	Totaliser 3 - Value (REAL)	REAL	RO

Table 8-1: Modbus map - Registers

8.1.2 Coils / Discrete inputs

The following table is a list of all binary data (discrete inputs / coils) available sorted by ascending addresses.

- RW = read-write

Coil Address	Qty.	Name	Type	Access
1000 (0x03E8)	1	Restart Device	BOOL	RW
1001 (0x03E9)	1	Reset Errors	BOOL	RW
1002 (0x03EA)	1	Apply Changes	BOOL	RW
1003 (0x03EB)	1	Discard Changes	BOOL	RW
1004 (0x03EC)	1	Factory Reset	BOOL	RW
3000 (0x0BB8)	1	Totaliser 1 Control	BOOL	RW
3001 (0x0BB9)	1	Totaliser 2 Control	BOOL	RW
3002 (0x0BBA)	1	Totaliser 3 Control	BOOL	RW
3003 (0x0BBB)	1	Totaliser 1 Reset	BOOL	RW
3004 (0x0BBC)	1	Totaliser 2 Reset	BOOL	RW
3005 (0x0BBD)	1	Totaliser 3 Reset	BOOL	RW
4200 (0x1068)	1	Zero Calibration	BOOL	RW

Table 8-2: Modbus map - Coils / Discrete inputs

8.2 Troubleshooting

Please study the standard documentation carefully and try these troubleshooting solutions before contacting our customer service.

8.2.1 No response to Modbus requests

There are several possibilities why no response would be received from the transmitter.

Here is a list of some of the more obvious things to check:

- Check that there is an appropriate voltage input on the V+ and V- terminals of the transmitter.
- Ensure that there is continuity between the terminals (for details refer to *Electrical connection* on page 15) and their associated terminals at the master device. Check that D0 and D1 are connected correctly (popular "RS-485 A/B confusion", for details refer to *Signals* on page 9). Ensure that there is a proper "Common" connection between the master device and the transmitter.
- The transmitter will ignore messages that are not addressed to it, or any message that contains fundamental formatting errors. Check that the address ID that is being requested is correct, the default value is 1. Check that the transmission rate (default = 19200 Baud) and format (default = 8 data bits, even parity and 1 stop bit) are correct.

8.2.2 Communication errors

Intermittent communication errors can have several causes, almost all of which can be attributed to the quality of the connection between the master device and the transmitter, such as:

- Low quality connections at the terminals of the transmitter or master device. Ensure that good contact is being made and that the connections are not frayed or corroded.
- Cable lengths and/or cable capacitance are too high for the data rate being used.
- Powerful sources of electromagnetic interference near the path of the cable route.
- Unfavourable choice of bus topology (for details refer to *Topologies* on page 11)
- No bus termination (and bus polarisation).

Cross-talking can lead to communication errors due to duplicate addresses or too tight bus timings (e.g. response timeout).

8.2.3 Exception responses

Check the following subsection if the transmitter returns Modbus exception responses (for details refer to *Modbus Exceptions* on page 31).

"Illegal Function"

Modbus Exception Code 1 "ILLEGAL FUNCTION"

- The function being requested is not valid for the transmitter; check the list of valid Modbus function codes. For further information refer to *Supported Function Codes* on page 28.
- The request telegram is formatted fundamentally wrong and cannot be interpreted by the Modbus slave any further.

8.2.4 "Illegal Data Address"

Modbus Exception Code 2 "ILLEGAL DATA ADDRESS"

There are some reasons why the transmitter will return an "Illegal Data Address" error message when the master device makes a request.

- The start register address being requested is not supported by the transmitter, check the requested register against the registers specified (for details refer to *Data list* on page 36). Note that the register addresses start from zero (for details refer to *Data addresses* on page 20).
- Although the start address is valid, when accessing multiple registers, the number of registers requested may extend beyond the end of the valid address range for that group of data items. Check the quantity of registers requested and ensure that the last register address is valid.
- The number of registers requested is not correct for the data type(s) being requested. It is not allowed to access data items incompletely (for details refer to *Data mapping* on page 23).

8.2.5 "Illegal Data Value"

Modbus Exception Code 3 "ILLEGAL DATA VALUE"

The function being requested is not valid (e.g. quantity of registers exceeds specification). Refer to Modbus Application Layer Protocol specification.

8.2.6 "Server Device Failure"

Modbus Exception Code 4 "SERVER DEVICE FAILURE"

An error occurred while processing the request. This may occur for read-requests but most likely occurs for write-requests. Write requests will be checked for validity and any errors will be reported with this exception.

Examples:

- insufficient access rights
- invalid value (too high, too low or not in the list of allowed values)
- erroneous command
- not allowed to write a read-only data item

The Improved Exception Handling is intended to help to identify the source (for details refer to *Improved Exception Handling* on page 32).

8.2.7 Service questionnaire

Before contacting our customer service, please gather as many information about the transmitter and circumstances as possible so that you receive fast and purposeful help.

The following table will give you some idea of what might be important.

Product	Name, product code(s), version(s) of the measurement device / transmitter
Serial number(s)	Serial number(s)
Error description	What does not work? What is the expectation?
Modbus master	Which Modbus master is used? (vendor, product, version)
Modbus network	Bus topology and cabling Bus termination / polarisation Shielding / grounding arrangements
Communication parameters	Baud rate, frame format, addresses
Display	What is being displayed on the status message page?
Modbus exceptions	Does the transmitter respond with exception responses? If so, which ones?
Modbus data	Which data is being requested from the transmitter?
What was done?	What measures have been taken to correct the errors?
Additional information	Photos, sketches, data logs, ...

Table 8-3: Modbus service questionnaire

Schneider Electric Systems USA, Inc. Global Customer Support
70 Mechanic Street Inside U.S.: 1-866-746-6477
Foxboro MA 02035-2037 Outside U.S.: 1-508-549-2424
United States of America <https://pasupport.schneider-electric.com>
<http://www.se.com>

Copyright 2020 Schneider Electric Systems USA, Inc.
All rights reserved.

The Schneider Electric brand and any trademarks of
Schneider Electric SE or its subsidiaries are the property
of Schneider Electric SE or its subsidiaries.
All other trademarks are the property of their respective
owners.

