

Instruction

MI 019-036 en

December 2020

CFS400A Coriolis Flow Sensor

Master Instruction

All rights reserved. It is prohibited to reproduce this documentation, or any part thereof, without the prior written authorisation of Schneider Electric Systems USA, Inc.

Copyright 2019-2020 Schneider Electric Systems USA, Inc.

1	Safety instructions	5
<hr/>		
1.1	Intended use	5
1.2	CE certification	5
1.3	Associated documents	6
1.4	Pressure Equipment Directive (PED)	6
1.5	Dirty gas	7
1.6	Safety instructions from the manufacturer	7
1.6.1	Copyright and data protection	7
1.6.2	Disclaimer	8
1.6.3	Product liability and warranty	9
1.6.4	Information concerning the documentation	9
1.6.5	Warnings and symbols used	10
1.7	Safety instructions for the operator	11
2	Device description	12
<hr/>		
2.1	Model identification	12
2.2	Scope of delivery	12
2.3	Nameplates	13
2.4	CSA dual seal	13
2.5	Temperature differential and thermal shock	14
3	Installation	16
<hr/>		
3.1	General notes on installation	16
3.2	Storage	16
3.3	Handling	17
3.4	Installation conditions	19
3.4.1	Supporting the meter	19
3.4.2	Mounting the meter	20
3.4.3	Side mounting	21
3.4.4	Cross talk	21
3.4.5	Flange connections	22
3.4.6	Maximum pipework forces (end loadings)	23
3.4.7	Pipework reducers	23
3.4.8	Flexible connections	23
3.4.9	Heating and insulation	24
3.4.10	Purge ports	26
3.4.11	Burst discs	26
3.4.12	Zero calibration	26
3.4.13	Sunshades	27

4	Electrical connections	28
<hr/>		
4.1	Safety instructions.....	28
4.2	Electrical and I/O connections	28
5	Service	29
<hr/>		
5.1	Spare parts availability.....	29
5.2	Availability of services	29
5.3	Returning the device to the manufacturer.....	29
5.3.1	General information.....	29
5.3.2	Preapproval form - Customer returned process-wetted products.....	30
5.4	Disposal	31
6	Technical data	32
<hr/>		
6.1	Measuring principle (multiple tube).....	32
6.2	Technical data.....	33
6.3	ATEX temperature limits	37
6.4	Maximum end loadings	38
6.5	Measuring accuracy	39
6.6	Guidelines for maximum operating pressure.....	40
6.7	Dimensions and weights	42
6.7.1	Flanged versions.....	42
6.7.2	Heating jacket version	48
6.7.3	Purge port option	49

1.1 Intended use

This mass flowmeter is designed for the direct measurement of mass flow rate, product density and product temperature. Indirectly, it also enables the measurement of parameters like total mass, concentration of dissolved substances and the volume flow. For use in hazardous areas, special codes and regulations are also applicable and these are specified in separate documentation.

**CAUTION!**

Responsibility for the use of the measuring devices with regard to suitability, intended use and corrosion resistance of the used materials against the measured fluid lies solely with the operator.

**NOTICE!**

This device is a Group 1, Class A device as specified within CISPR11:2009. It is intended for use in industrial environment. There may be potential difficulties in ensuring electromagnetic compatibility in other environments, due to conducted as well as radiated disturbances.

**NOTICE!**

The manufacturer is not liable for any damage resulting from improper use or use for other than the intended purpose.

1.2 CE certification

CE marking



This device conforms with the most recent and up to date versions of the following:

- EMC Directive
- ATEX Directive
- Low Voltage Directive
- Pressure Equipment Directive (PED)
- RoHS
- Measuring Instrument Directive
- Radio Equipment Directive (RED)

The manufacturer declares conformity and the device carries the CE mark.

1.3 Associated documents

This handbook should be read in conjunction with relevant documents in relation to:

- hazardous areas
- communications
- concentration
- corrosion

1.4 Pressure Equipment Directive (PED)

**LEGAL NOTICE!**

The Pressure Equipment Directive places legal requirements on both the manufacturer and the end user. Please read this section carefully!

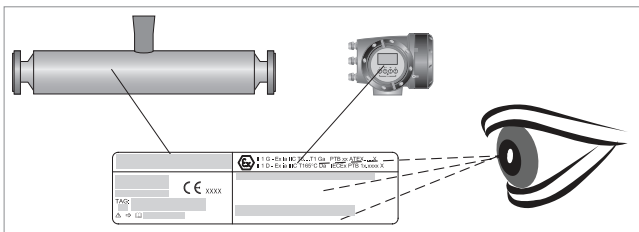
Visual check

To ensure the PED integrity of the meter, you **MUST** check that the serial numbers on the transmitter nameplate and the sensor nameplate are the same.

To comply with the requirements of the Pressure Equipment Directive (PED) the manufacturer provides all the relevant technical data in the technical data section of this handbook. In addition to which, the following should also be noted:

- Secondary pressure containment is **NOT** supplied as standard.
- The non PED / CRN approved outer cylinder has a typical burst pressure greater than 100 barg / 1450 psig at 20°C / 68°F.
- The wiring feedthrough is made of Epoxy, PPS or PEEK with two O-rings made from FPM / FKM & Hydrogenated Nitrile.
- If the measuring tube/s fails, the O-ring and feedthrough will be in contact with the process product.
- You **MUST** make sure that the O-ring and feedthrough material is suitable for the application.
- Alternative O-ring materials are available on request.

Secondary pressure containment

Where the meter is being used to measure high pressure gases and / or gases kept as liquids by high pressure and / or where there is a risk of tube failure because of the use of corrosive or erosive fluids, frequent pressure and / or thermal cycling, seismic or other shock loading, a secondary containment option **MUST** be purchased.

Where the above situation applies and the process pressure exceeds the secondary pressure containment (please refer to technical data) or where secondary pressure containment is not available, the burst disc option **MUST** also be purchased. For more information, please contact your nearest representative.

**DANGER!**

If it is suspected that the primary measuring tube has failed, de-pressurise the meter and remove it from service as soon as it is safe to do so.

1.5 Dirty gas

Dirty gas is gas that carries sand or other solid particles. Dirty gas causes excessive wear to the primary measuring tube that can eventually result in complete tube failure. In some situations tube failure where gas is being measured, can be very dangerous.

**DANGER!**

If the meter is being used to measure gas and there is a risk that the gas might be dirty, you must fit a filter upstream of the meter to catch solid particles.

1.6 Safety instructions from the manufacturer

1.6.1 Copyright and data protection

The contents of this document have been created with great care. Nevertheless, we provide no guarantee that the contents are correct, complete or up-to-date.

The contents and works in this document are subject to copyright. Contributions from third parties are identified as such. Reproduction, processing, dissemination and any type of use beyond what is permitted under copyright requires written authorisation from the respective author and/or the manufacturer.

The manufacturer tries always to observe the copyrights of others, and to draw on works created in-house or works in the public domain.

The collection of personal data (such as names, street addresses or e-mail addresses) in the manufacturer's documents is always on a voluntary basis whenever possible. Whenever feasible, it is always possible to make use of the offerings and services without providing any personal data.

We draw your attention to the fact that data transmission over the Internet (e.g. when communicating by e-mail) may involve gaps in security. It is not possible to protect such data completely against access by third parties.

We hereby expressly prohibit the use of the contact data published as part of our duty to publish an imprint for the purpose of sending us any advertising or informational materials that we have not expressly requested.

1.6.2 Disclaimer

The manufacturer will not be liable for any damage of any kind by using its product, including, but not limited to direct, indirect or incidental and consequential damages.

This disclaimer does not apply in case the manufacturer has acted on purpose or with gross negligence. In the event any applicable law does not allow such limitations on implied warranties or the exclusion or limitation of certain damages, you may, if such law applies to you, not be subject to some or all of the above disclaimer, exclusions or limitations.

Any product purchased from the manufacturer is warranted in accordance with the relevant product documentation and our Terms and Conditions of Sale.

The manufacturer reserves the right to alter the content of its documents, including this disclaimer in any way, at any time, for any reason, without prior notification, and will not be liable in any way for possible consequences of such changes.

1.6.3 Product liability and warranty

The operator shall bear responsibility for the suitability of the device for the specific purpose. The manufacturer accepts no liability for the consequences of misuse by the operator. Improper installation or operation of the devices (systems) will cause the warranty to be void. The respective "Standard Terms and Conditions" which form the basis for the sales contract shall also apply.

1.6.4 Information concerning the documentation

To prevent any injury to the user or damage to the device it is essential that you read the information in this document and observe applicable national standards, safety requirements and accident prevention regulations.

If this document is not in your native language and if you have any problems understanding the text, we advise you to contact your local office for assistance. The manufacturer can not accept responsibility for any damage or injury caused by misunderstanding of the information in this document.

This document is provided to help you establish operating conditions, which will permit safe and efficient use of this device. Special considerations and precautions are also described in the document, which appear in the form of icons as shown below.

1.6.5 Warnings and symbols used

Safety warnings are indicated by the following symbols.



DANGER!

This warning refers to the immediate danger when working with electricity.



DANGER!

This warning refers to the immediate danger of burns caused by heat or hot surfaces.



DANGER!

This warning refers to the immediate danger when using this device in a hazardous atmosphere.



DANGER!

These warnings must be observed without fail. Even partial disregard of this warning can lead to serious health problems and even death.



WARNING!

Disregarding this safety warning, even if only in part, poses the risk of serious health problems. There is also the risk of damaging the device or parts of the operator's plant.



CAUTION!

Disregarding these instructions can result in damage to the device or to parts of the operator's plant.



NOTICE!

These instructions contain important information for the handling of the device.



LEGAL NOTICE!

This note contains information on statutory directives and standards.



• **HANDLING**

This symbol designates all instructions for actions to be carried out by the operator in the specified sequence.

➔ **RESULT**

This symbol refers to all important consequences of the previous actions.

1.7 Safety instructions for the operator



WARNING!

In general, devices from the manufacturer may only be installed, commissioned, operated and maintained by properly trained and authorized personnel.

This document is provided to help you establish operating conditions, which will permit safe and efficient use of this device.

2.1 Model identification

Model	Nameplate
404	S100
406	S150
410	S250
416	S400

2.2 Scope of delivery

Compact version

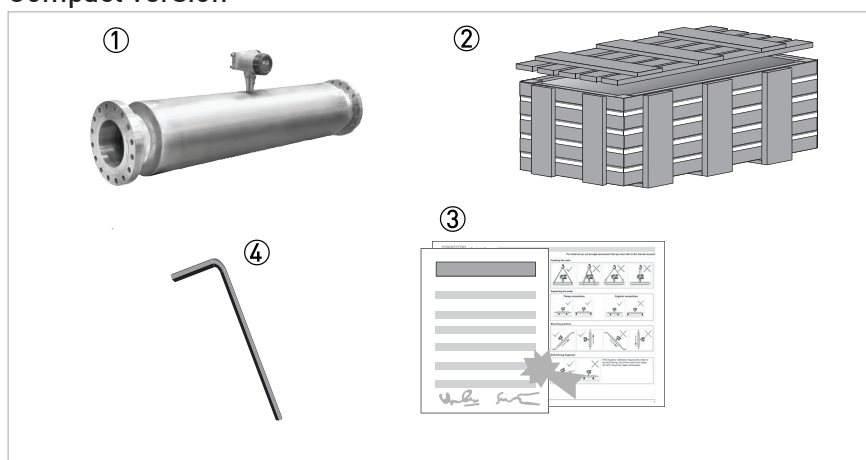

- ① Mass flowmeter.
- ② Crate.
- ③ Documentation.
- ④ 2.5 mm hex head tool.

Remote version

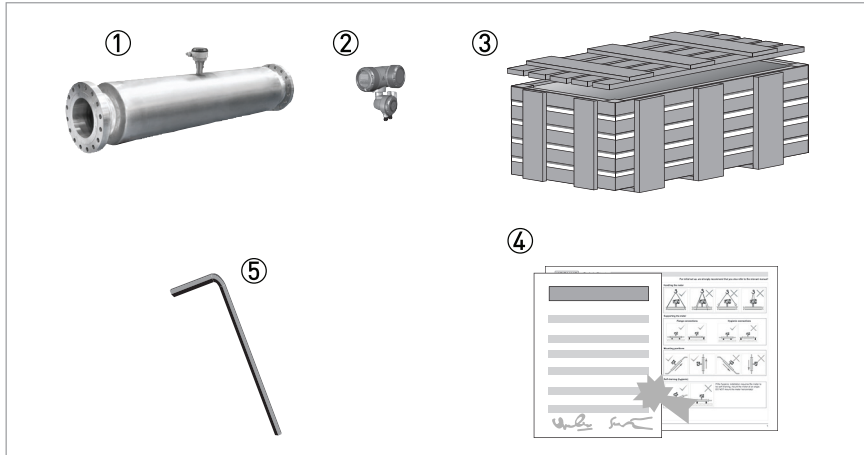

- ① Mass flowmeter.
- ② Transmitter. This will be either: field (as shown) or wall.
- ③ Crate.
- ④ Documentation.
- ⑤ 2.5 mm hex head tool.

If any items are missing, please contact the manufacturer.

If your meter has flange connections, the flange specification is stamped on the outer edge of the flange. Check that the specification on the flange is the same as your order.

2.3 Nameplates



NOTICE!

Look at the device nameplate to ensure that the device is delivered according to your order. Check for the correct supply voltage printed on the nameplate.

2.4 CSA dual seal

To comply with the requirements of ANSI/ISA -12.27.01-2011 "Requirements for process Sealing Between electrical systems and Flammable or Combustible process Fluids" a secondary seal is incorporated into all Coriolis Flow Sensor products. If the primary seal fails, the secondary seal will prevent escaping fluid reaching the electronic compartment.

Pressures and / or temperatures are limited by tube, temperature, connection and Ex limits. Check the meter nameplates and relevant documentation for full details. On all meters operating on gas measurement, the casing of the meter is fitted with a burst disc. If the primary seal (tube) fails leakage will occur from the burst disc. Install the meter so that the burst disc is pointing away from personnel.

Liquids (Example model code: CFS 400C - LIQUID)

Pressure and temperature data:

CFS 400C -45°C...+130°C and 100...14000 kPa

If the primary seal fails, the casing of the meter will fill with liquid and the meter will stop working. The meter will notify the operator by displaying the status message "Sensor: Sensor signal low" on the transmitter or PLC display. This is an indication that the primary seal (tube) has failed and the status of the meter should be checked.

Meter status:

The meter will also display the message "Sensor: Sensor signal low" if the measuring tubes are not completely filled with fluid. For example, if the meter is drained or re/filled. To check the status of the meter, drain and re/fill with fluid and note the transmitter or PLC display. See the relevant section of the transmitter handbook for a list of status messages and diagnostics information.

If the meter continues to display the message: "Sensor: Sensor signal low" you MUST assume that the primary seal (tubes) has failed and the appropriate action MUST be taken.

Gases (Example model code: CFS 300F - GAS)

Pressure / temperature data:

CFS 400F -45°C...+130°C and 500...14000 kPa

Pressures and/or temperatures may be further limited by tube, temperature, connection and Ex limits. Consult the meter nameplate and relevant documentation for full details.

On all meters operating on gas measurement the casing of the meter is fitted with a burst disc. If the primary seal (tube/s) fails leakage will occur from the burst disc. Install the meter so that the burst disc is pointing away from personnel.

Regular maintenance of the burst disc:

Carry out regular maintenance checks on burst discs for leakage and/or blockages. On all Coriolis Flow Sensor meters, the primary seal is considered to be the measuring tube of the meter. The materials of construction of the measuring tube/s are described within the relevant sections of this handbook and the customer's product and any other fluid flowing through the tube must be compatible with the material of construction. If failure of the primary seal is suspected then the process line should be de-pressurised and the meter removed as soon as it is safe to do so. Please contact customer service for servicing or replacement of the meter.

2.5 Temperature differential and thermal shock

Temperature differential

The maximum difference between ambient temperature and process (operating) temperature is 100°C / 212°F.

Thermal shock

Thermal shock occurs when there is a sudden and extreme change (shift) in process temperature. To avoid thermal shock, refer to the following table for the maximum temperature shift.

Meter	Maximum temperature shift
S100	+90°C / +194°F (+110°C / +230°F with a maximum operating pressure of 40 barg / 580 psig)
S150	+80°C / +176°F
S250	+50°C / +122°F
S400	+50°C / +122°F

**CAUTION!**

Operation outside these limits may result in shifts in density and mass flow calibration. Repeated shocking may also lead to premature failure of the meter! However, higher thermal shocks are possible at lower working pressures. For more information, please contact your nearest representative.

3.1 General notes on installation

**NOTICE!**

Inspect the packaging carefully for damages or signs of rough handling. Report damage to the carrier and to the local office of the manufacturer.

**NOTICE!**

Do a check of the packing list to make sure that you have all the elements given in the order.

**NOTICE!**

Look at the device nameplate to ensure that the device is delivered according to your order. Check for the correct supply voltage printed on the nameplate.

3.2 Storage

- Store the device in a dry and dust-free location.
- Avoid direct exposure to the sun.
- Store the device in its original packing.
- Do not allow the ambient temperature to fall below -50°C / -58°F or rise above +85°C / +185°F. (-40°C / -40°F and +70°C / +158°F. where a SIL capable Transmitter has been supplied)

3.3 Handling

Using a sling to lift and carry the meter

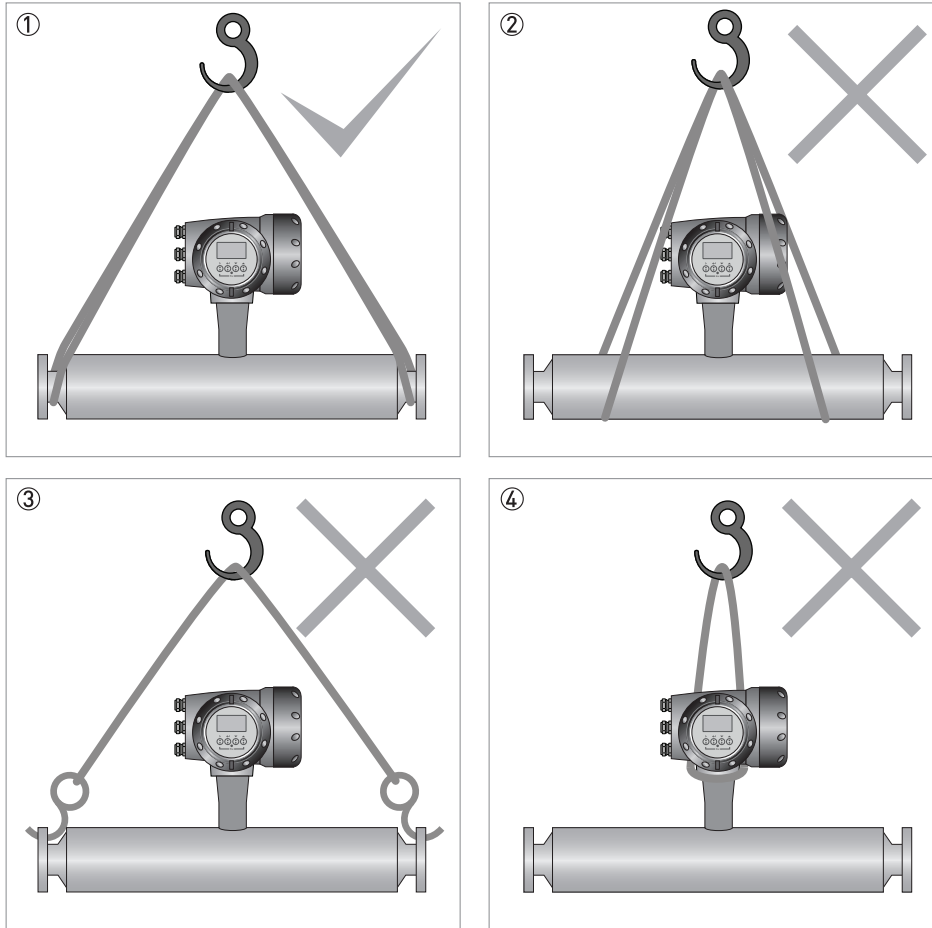

- ① Use a well maintained sling to lift the meter by the spigots.
- ② DO NOT lift the meter with the sling part way along the outer cylinder.
- ③ DO NOT lift the meter using the flange bolt holes.
- ④ DO NOT lift the meter by the transmitter housing or the electronics stem.

Standing the meter before installation

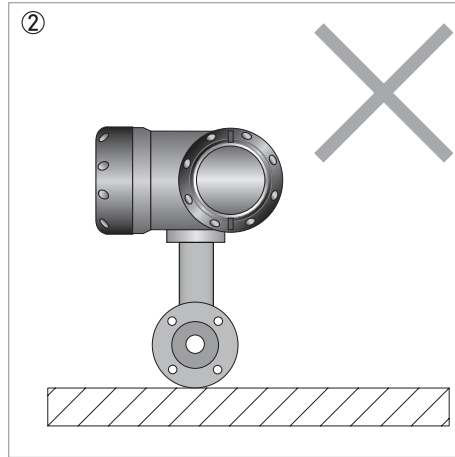
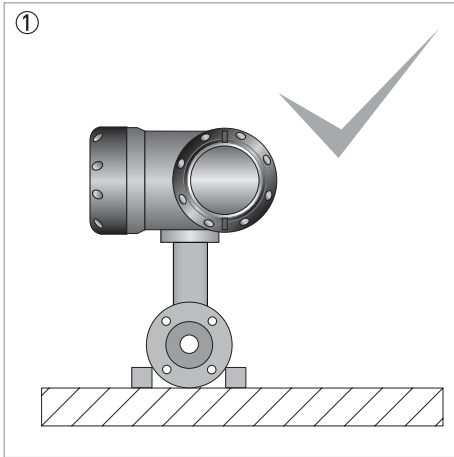

- ① When standing the meter prior to installation, use blocks or similar to keep the meter upright.
- ② NEVER stand the meter upright without blocks (or similar) .

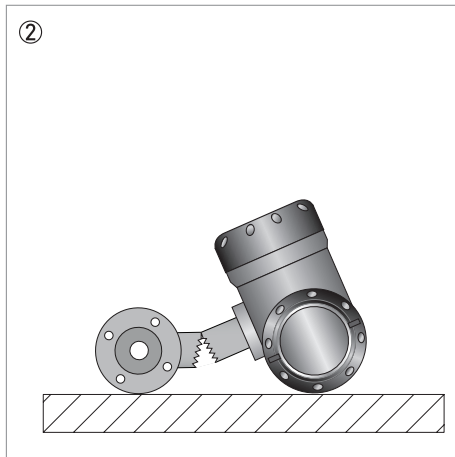
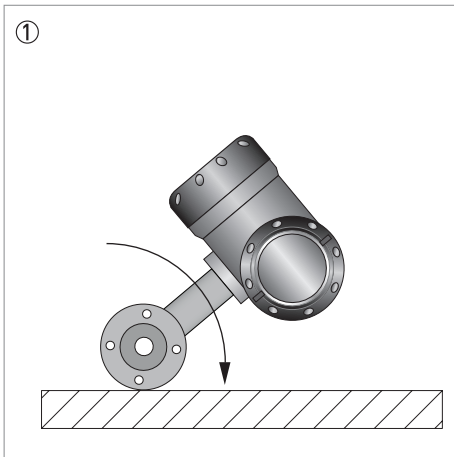

- ① If the meter is not blocked it can roll over
- ② This can cause severe damage to the meter, or injury to personnel

3.4 Installation conditions

3.4.1 Supporting the meter

Support for meters with flange connections

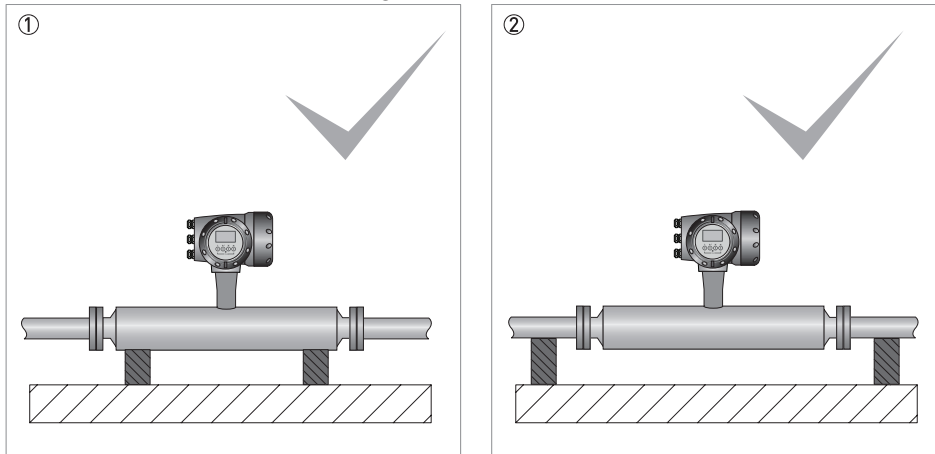

- ① The meter can be supported directly by its body
- ② The meter can also be supported by the process pipework

3.4.2 Mounting the meter

Mounting positions

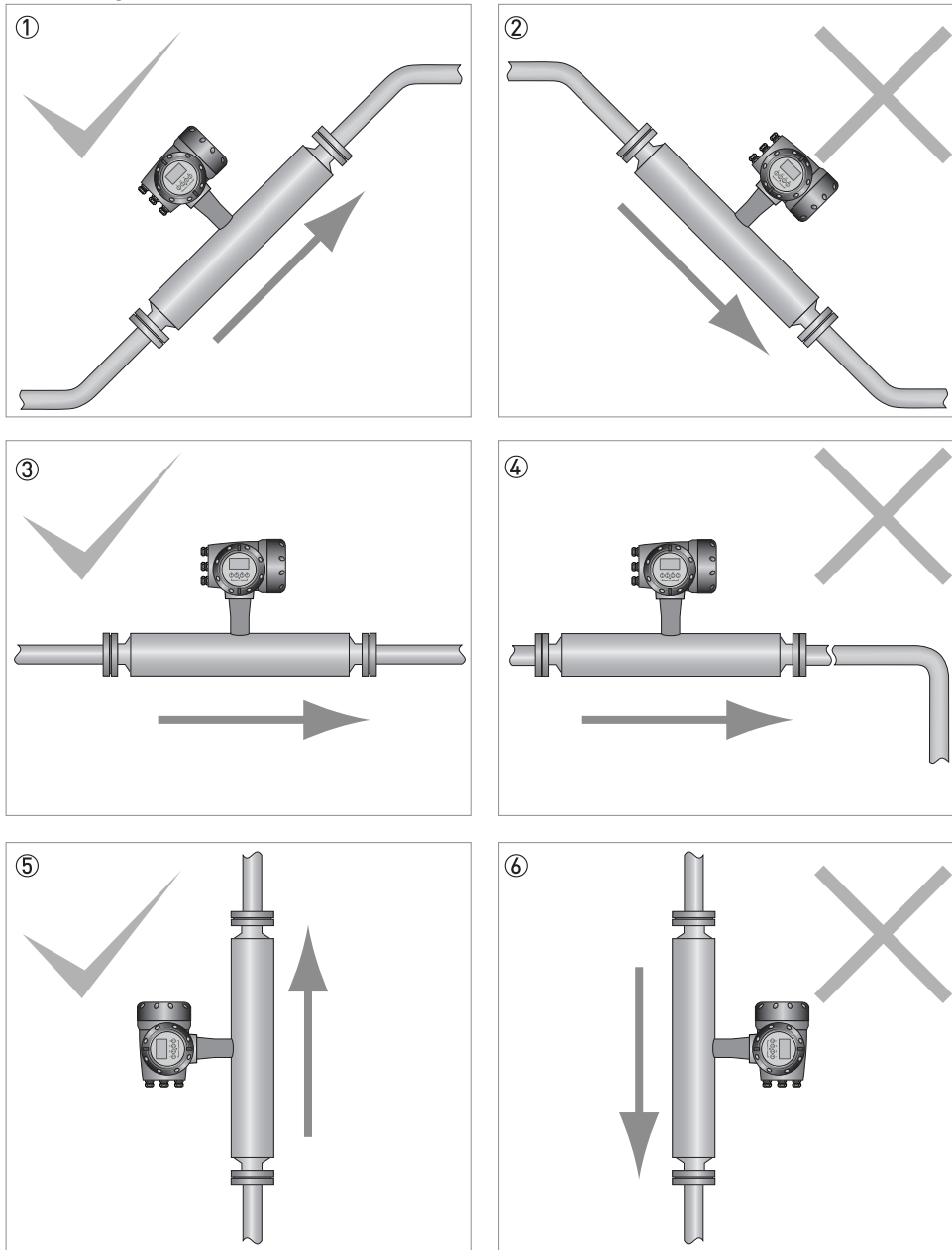

- ① The meter can be mounted at an angle but it is recommended that the flow is uphill.
- ② Avoid mounting the meter with the flow running downhill because it can cause siphoning. If the meter has to be mounted with the flow running downhill, install an orifice plate or control valve downstream of the meter to maintain backpressure.
- ③ Horizontal mounting with flow running left to right.
- ④ Avoid mounting meter with long vertical runs after the meter as it can cause cavitation. Where the installation includes a vertical run after the meter, install an orifice plate or control valve downstream to maintain backpressure.
- ⑤ The meter can be mounted vertically but it is recommended that the flow is uphill.
- ⑥ Avoid mounting the meter vertically with the flow running downhill. This can cause siphoning. If the meter has to be installed this way, install an orifice plate or control valve downstream to maintain backpressure.

3.4.3 Side mounting

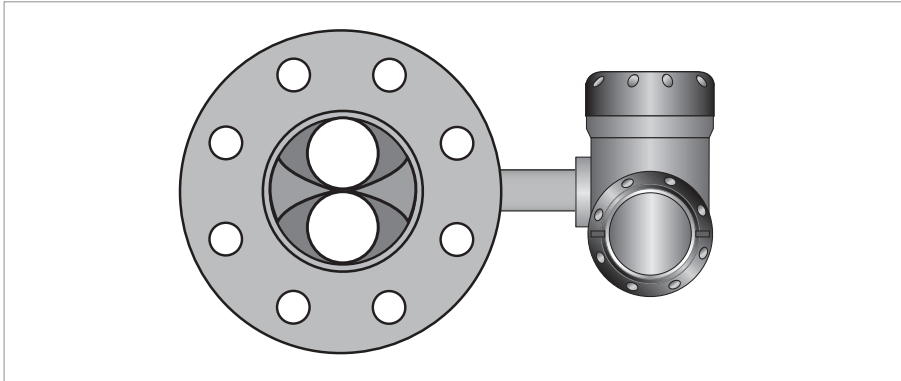

The meter can be installed with the Transmitter (or remote junction box) on the side of the meter so that the measuring tubes are sitting one above the other. Avoid this method of installation where there is a two phase process flow, or where the process fluid contains gas. If this situation cannot be avoided, please contact the manufacturer for advice.

3.4.4 Cross talk

Where more than one meter is being installed, a very high level of immunity to cross talk means that the meters can be mounted within close proximity to each other. The meters can be mounted either in series or parallel, as shown.

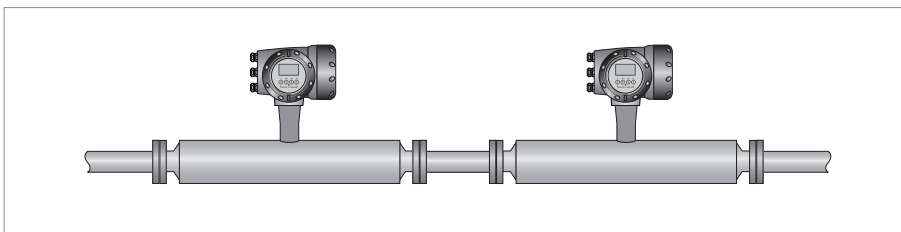
**NOTICE!**

Where the meters are installed in series, it is strongly recommended that the process pipe diameter remains constant. For more information, please contact the manufacturer.

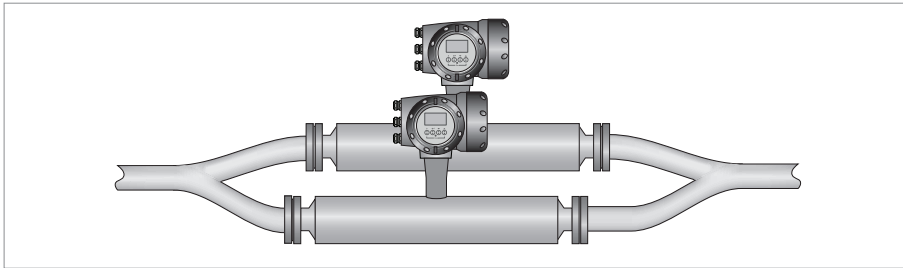

3.4.5 Flange connections

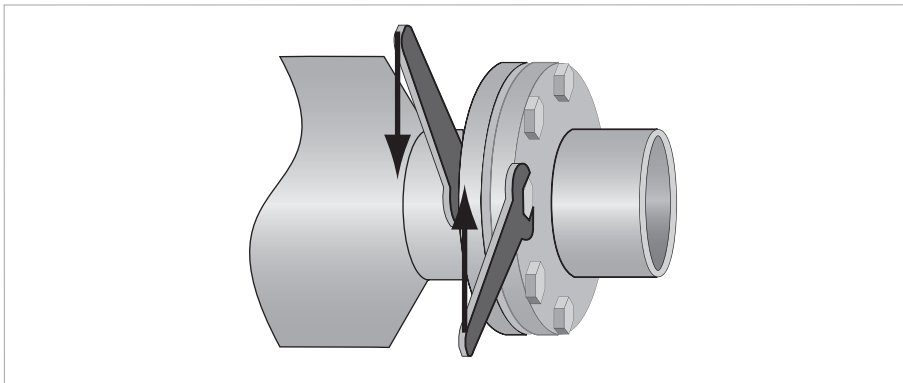

Tighten the flange bolts evenly and in turn.

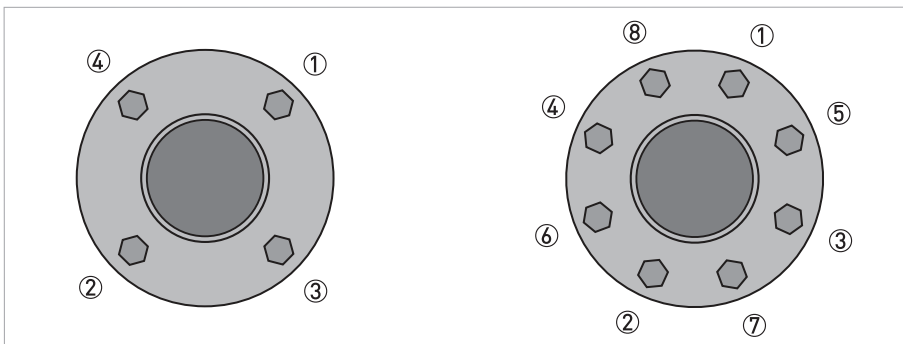

Use a regular pattern to tighten the bolts evenly

3.4.6 Maximum pipework forces (end loadings)

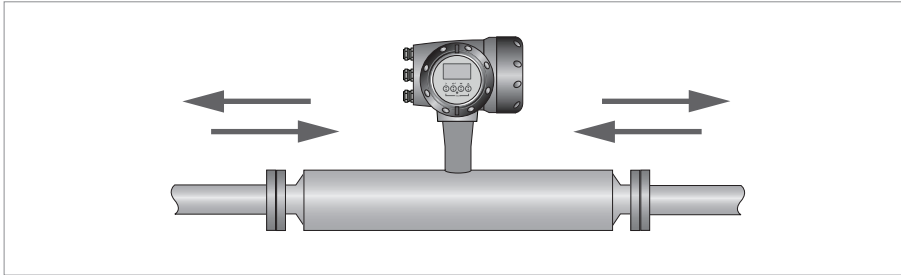

Mass flowmeters have a maximum level of force (negative or positive) that can be applied to the ends of the meter. Refer to the table in the technical data section of this Handbook for the maximum end loadings.

3.4.7 Pipework reducers

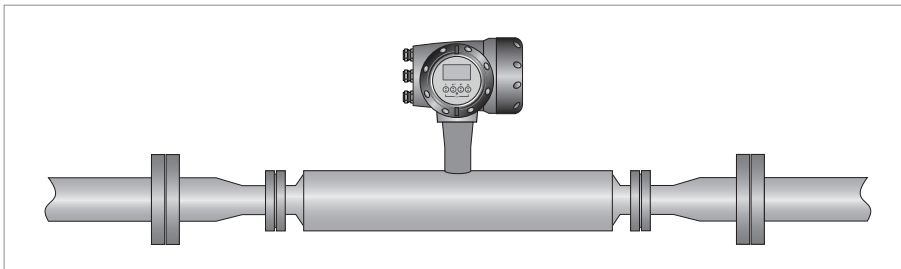

Always avoid extreme step changes in pipe size. Use pipework reducers, where there is a large difference between pipework size and meter flanges.

3.4.8 Flexible connections

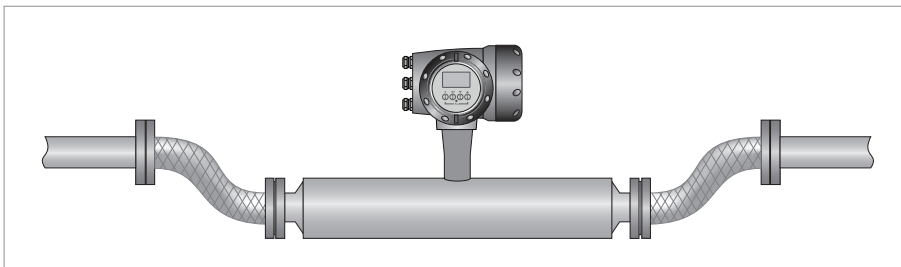

Flexible connections can be used but because of the high flow rates associated with large diameter meters, it is recommended that flexible connections are not used on meters larger than size 80.

3.4.9 Heating and insulation

Heating

The meter can be heated by electrical tape (or similar) as shown. ONLY heat the meter in the area marked A.

Insulation

The meter can also be insulated to a maximum depth as shown (B). Do not insulate above this depth as this will cause the electronics to overheat.

Electrical heating and insulation

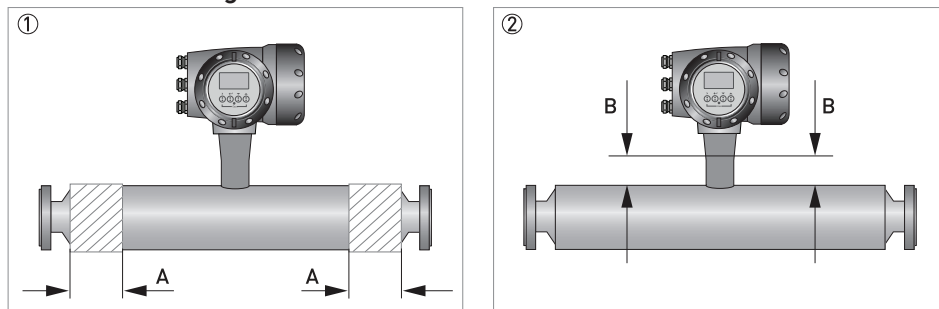

- ① Area that can be heated (A). Refer to the table for the maximum sizes.
- ② Maximum depth of insulation (B). Refer to the table.

Heated area

		S100	S150	S250	S400
Dimension of A	mm	200	250	250	290
	Inches	7.9	9.8	9.8	11.4
Dimension of B	mm	50			
	Inches	2.0			

Factory fitted heating jacket

If the meter has been ordered with a heating jacket, it will be supplied with NPT, Ermeto or flange connections.

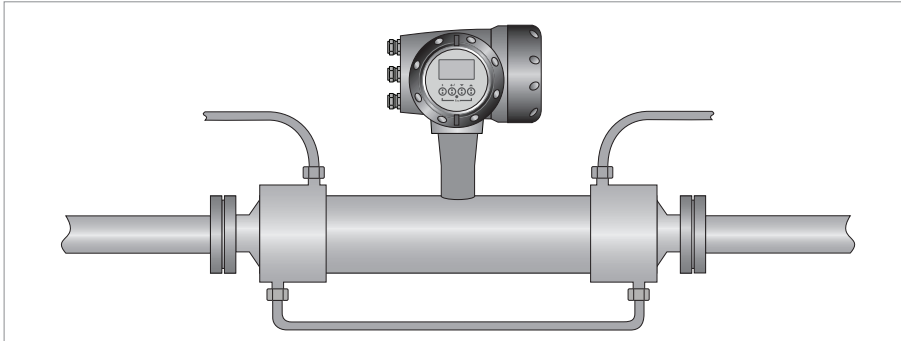

Connecting / using the heating jacket

- Use reinforced flexible hoses to connect the heating jacket to the heat source.
- The heating jacket material is 316L but the heating medium is also in contact with the outer cylinder, which might be a lower grade stainless steel.
- Suitable heating mediums are steam or hot oil. Avoid the use of heating mediums that can cause crevice corrosion in Stainless Steel.
- Where liquid is being used, set up the pipe configuration so that air can be vented from the system.
- Where steam is being used, set up the pipe configuration so that condensation can be drained off.
- Heat the jacket to working temperature before flowing the process fluid through the meter.



CAUTION!

The maximum heating pressure and temperature for heating jackets is 10 barg at 130°C / 145 psig at 266°F

Heating times

Temperature [°C / °F] ①	Time [minutes]			
	S100	S150	S250	S400
40 / 104	7	7	10	12
60 / 140	10	10	17	20
80 / 176	15	15	30	35
100 / 212	20	20	60	65
110 / 230	30	50	90	100
120 / 248	75	200	270	280

① Measured at the spigot end of the measuring tube.

Reference conditions

Ambient temperature	+25°C / +77°F
Heating medium	Hot liquid
Heating medium temperature	+130°C / +266°F

3.4.10 Purge ports

If the meter has been ordered with a purge port, it will be supplied with NPT female connections which are clearly marked. The connections are sealed with NPT plugs and PTFE tape.

**CAUTION!**

DO NOT remove these plugs.

The meter is factory sealed with a dry nitrogen gas fill and if moisture is allowed to enter the meter casing it will cause damage. The plugs should only be removed to purge the meter casing in the event that the primary measuring tube fails.

If it is suspected that the primary measuring tube has failed, de-pressurise the meter and remove it from service, as soon as it is safe to do so.

3.4.11 Burst discs

If the meter has been ordered with a burst disc, it will be supplied with the disc fitted. The failure pressure of the disc is 20 barg at +20°C / 290 psig at +68°F.

Automatic fitment

If the connection rating of the meter is greater than 100 barg / 1450 psig but the 150 barg / 2175 psig secondary containment option has not been purchased, the meter will be supplied with a burst disc fitted as a safety feature.

**CAUTION!**

The fitted burst disc will be suitable for the flow rates and process conditions specified on the original order. If the process conditions alter in any way, it is recommended that you contact the manufacturer for advice regarding suitability.

If the process product is hazardous (in any way) it is recommended that an exhaust tube is connected to the NPT male thread of the burst disc and the pipe routed so that the process product can be discharged to a safe area. Use a tube with a diameter large enough AND routed in such a way, so that pressure cannot build up in the meter case.

3.4.12 Zero calibration

The procedure for zero calibration is contained in the transmitter handbook. However, the following information should be considered when installing the meter.

Zero calibration

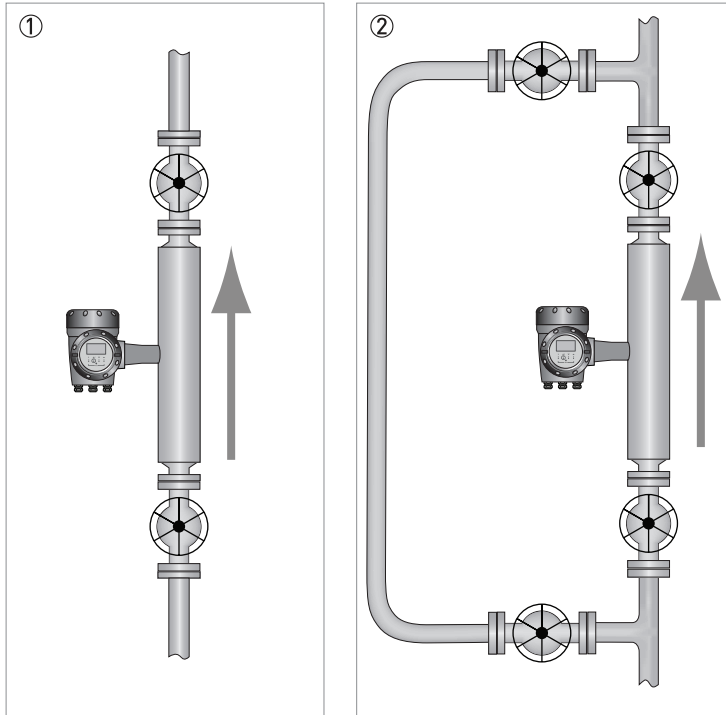

- ① Where the meter has been installed vertically, install shut-off valves either side of the meter to assist with zero calibration.
- ② If the process flow cannot be stopped, install a bypass section for zero calibration.

3.4.13 Sunshades

The meter **MUST** be protected from strong sunlight.

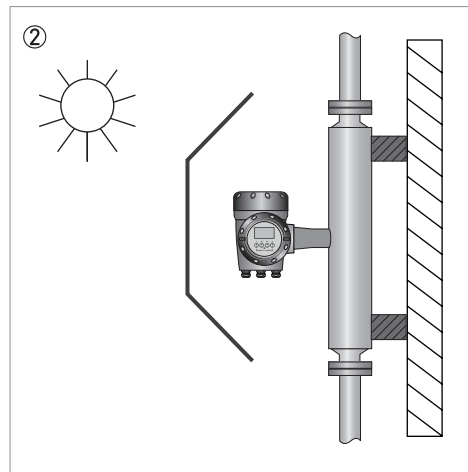
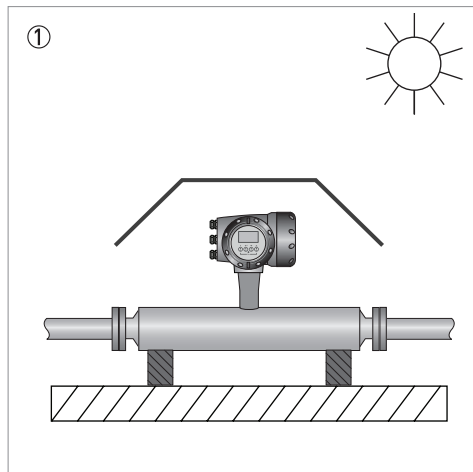

- ① Horizontal installation
- ② Vertical installation

4.1 Safety instructions

**DANGER!**

*All work on the electrical connections may only be carried out with the power disconnected.
Take note of the voltage data on the nameplate!*

**DANGER!**

Observe the national regulations for electrical installations!

**DANGER!**

For devices used in hazardous areas, additional safety notes apply; please refer to the Ex documentation.

**WARNING!**

*Observe without fail the local occupational health and safety regulations.
Any work done on the electrical components of the measuring device may only be carried out by properly trained specialists.*

**NOTICE!**

*Look at the device nameplate to ensure that the device is delivered according to your order.
Check for the correct supply voltage printed on the nameplate.*

4.2 Electrical and I/O connections

For information regarding electrical and I/O connections, please refer to the handbook for the relevant signal transmitter.

5.1 Spare parts availability

The manufacturer adheres to the basic principle that functionally adequate spare parts for each device or each important accessory part will be kept available for a period of 3 years after delivery of the last production run for the device.

This regulation only applies to spare parts which are subject to wear and tear under normal operating conditions.

5.2 Availability of services

The manufacturer offers a range of services to support the customer after expiration of the warranty. These include repair, maintenance, technical support and training.



NOTICE!

For more precise information, please contact your local sales office.

5.3 Returning the device to the manufacturer

5.3.1 General information

This device has been carefully manufactured and tested. If installed and operated in accordance with these operating instructions, it will rarely present any problems.



WARNING!

Should you nevertheless need to return a device for inspection or repair, please pay strict attention to the following points:

- *Due to statutory regulations on environmental protection and safeguarding the health and safety of the personnel, the manufacturer may only handle, test and repair returned devices that have been in contact with products without risk to personnel and environment.*
- *This means that the manufacturer can only service this device if it is accompanied by the following certificate (see next section) confirming that the device is safe to handle.*



WARNING!

If the device has been operated with toxic, caustic, radioactive, flammable or water-endangering products, you are kindly requested:

- *to check and ensure, if necessary by rinsing or neutralising, that all cavities are free from such dangerous substances,*
- *to enclose a certificate with the device confirming that it is safe to handle and stating the product used.*

5.3.2 Preapproval form - Customer returned process-wetted products



LEGAL NOTICE!

In compliance with U.S. Federal OSHA Standard 29CFR1910.1200 process information must be reviewed previous to receiving authorization to return material to Schneider Electric Systems USA, Inc.

NO PRODUCT EXPOSED TO HYDROFLUORIC ACID OR MERCURY WILL BE ACCEPTED!

Date: _____

Customer information

Customer's name:

Address:

Phone no:

Fax no.:

Contact's name:

Rep information

Rep's name:

Address:

Phone no:

Fax no.:

Contacts' name:

Product being returned:

Model No.:

Serial no.:

Under warranty?

YES

NO

Copies of MSDS sheets for all processes including cleaning solutions may be required.

Type of process (what chemicals/materials were processed through the unit):

Explain what steps were taken to decontaminate the unit: (was unit steam cleaned, rinsed out with water, chemically cleaned etc.)

Form completed by:

Print name

Signature

Date: _____

CLEANING STATEMENT

(Note: Your item will not be serviced unless the following cleaning statement has been signed):

I certify that the above referenced item has been properly purged and cleaned, complies with U.S. Department of Transportation shipping requirements and DOES NOT present a health and/or safety hazard (as defined by OSHA) to our Customer Repair personnel.

Print name: _____

Signature: _____

Print title: _____

Date: _____

Please fax the completed form to the Customer Satisfaction Center +1-508-549-4999

5.4 Disposal**LEGAL NOTICE!**

Disposal must be carried out in accordance with legislation applicable in your country.

Separate collection of WEEE (Waste Electrical and Electronic Equipment) in the European Union:

According to the directive 2012/19/EU, the monitoring and control instruments marked with the WEEE symbol and reaching their end-of-life **must not be disposed of with other waste**. The user must dispose of the WEEE to a designated collection point for the recycling of WEEE or send them back to our local organisation or authorised representative.

6.1 Measuring principle (multiple tube)

Static meter not energised and with no flow

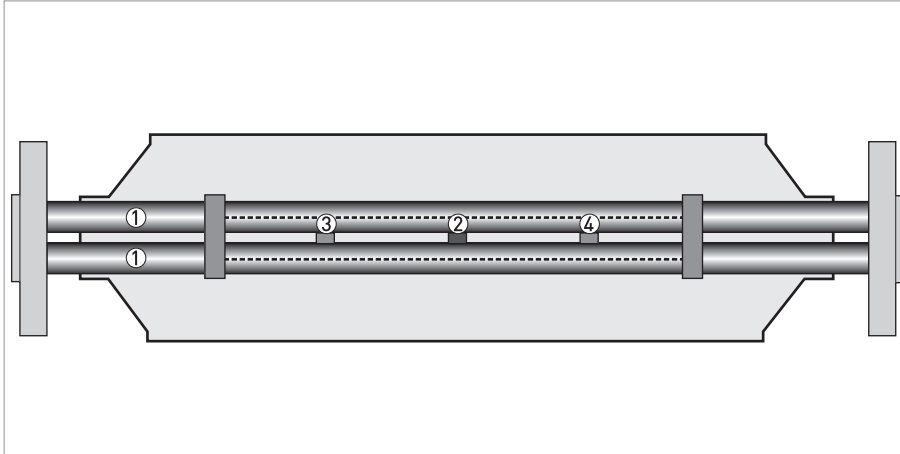

- ① Measuring tubes
- ② Drive coil
- ③ Sensor 1
- ④ Sensor 2

A Coriolis multiple tube mass flowmeter consists of either two or four measuring tubes ① one or two drive coils ② and two or four sensors (③ and ④). The sensors are positioned either side of the drive coil / s.

Energised meter

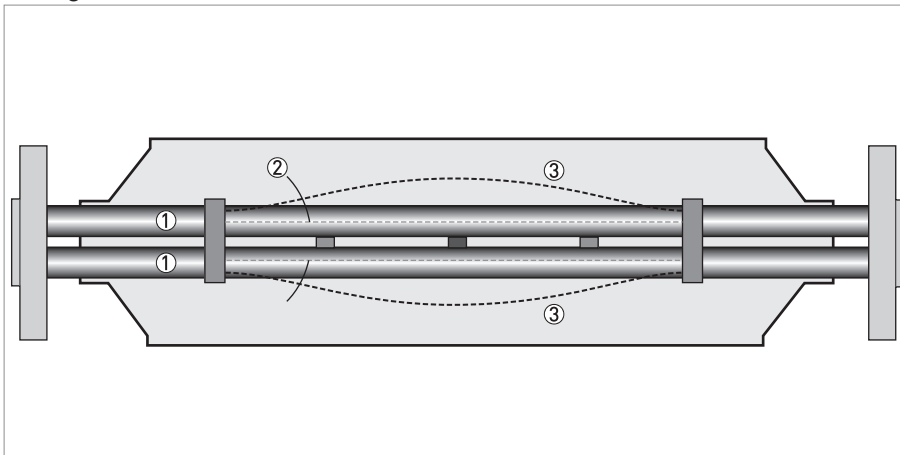

- ① Measuring tubes
- ② Direction of oscillation
- ③ Sine wave

When the meter is energised, the drive coil vibrates the measuring tubes causing them to oscillate and produce a sine wave ③. The sine wave is monitored by the two sensors.

Energised meter with process flow

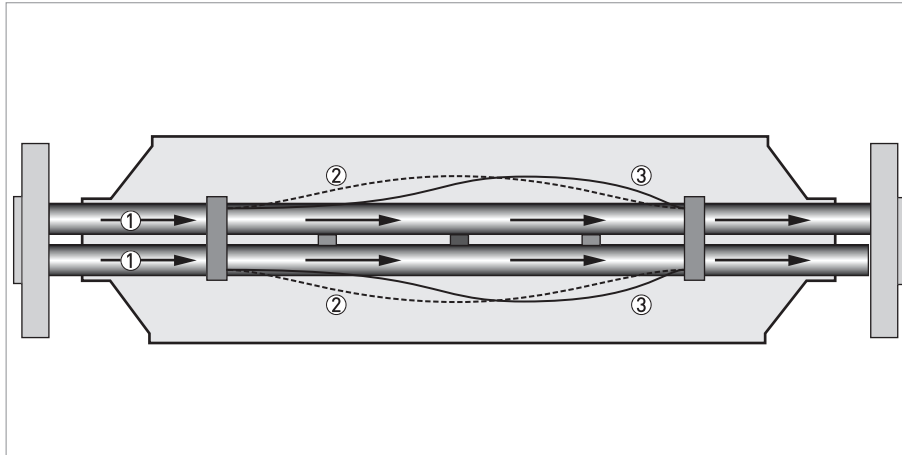

- ① Process flow
- ② Sine wave
- ③ Phase shift

When a fluid or gas passes through the tubes, the coriolis effect causes a phase shift in the sine wave that is detected by the two sensors. This phase shift is directly proportional to the mass flow. Density measurement is made by evaluation of the frequency of vibration and temperature measurement is made using a Pt500 sensor.

6.2 Technical data



NOTICE!

- *The following data is provided for general applications. If you require data that is more relevant to your specific application, please contact us or your local sales office.*
- *Additional information (certificates, special tools, software,...) and complete product documentation can be downloaded free of charge from the website.*

Measuring system

Measuring principle	Coriolis mass flow
Application range	Mass flow and density measurement of fluids, gases and solids
Measured values	Mass, density, temperature
Calculated values	Volume, referred density, concentration, velocity

Design

Basic	System consists of a measuring sensor and a transmitter to process the output signal
Features	Fully welded maintenance free sensor with multiple straight measuring tubes
Variants	
Compact version	Integral transmitter
Remote version	Available with field mount versions of the transmitter
Modbus version	Sensor with integral electronics providing Modbus output for connection to a PLC

Measuring accuracy

Mass standard	
Liquid ($\geq 20:1$ of nominal flow rate)	$\pm 0.1\%$ of actual measured flow rate
Liquid ($< 20:1$ of nominal flow rate)	\pm zero stability (see zero stability below)
Repeatability	
$\geq 20:1$ of nominal flow rate	Better than $\pm 0.05\%$
$< 20:1$ of nominal flow rate	Better than \pm zero stability x 0.5
Gas	$\pm 0.35\%$ of actual measured flow rate + zero stability
Repeatability	Better than 0.2% plus zero stability (includes the combined effects of repeatability, linearity and hysteresis)
Mass optional	
Liquid ($\geq 10:1$ of nominal flow rate)	$\pm 0.05\%$ of actual measured flow rate
Liquid ($< 10:1$ of nominal flow rate)	\pm zero stability (see zero stability below)
Repeatability	
$\geq 10:1$ of nominal flow rate	Better than $\pm 0.025\%$
$< 10:1$ of nominal flow rate	Better than \pm zero stability x 0.5

Zero stability	
S100	< 11 kg/h
S150	< 25 kg/h
S250	< 60 kg/h
S400	< 120 kg/h
Reference conditions	
Product	Water
Temperature	+20°C / +68°F
Operating pressure	1 barg / 14.5 psig
Effect on sensor zero point caused by a shift in process temperature	
Stainless Steel	0.0008% of nominal flow rate per 1°C / 0.00044% of nominal flow rate per 1°F
Effect on sensor zero point caused by a shift in process pressure	
Stainless Steel	0.0002% of the nominal flow rate per 1 barg / 0.000014% of the nominal flow rate per 1 psig
Density	
Measuring range	400...3000 kg/m ³ / 25...187 lb/ft ³
Accuracy	±1.0 kg/m ³ / ±0.06 lb/ft ³
On site calibration	±0.2 kg/m ³ / ±0.012 lb/ft ³
Temperature	
Accuracy	±1°C / ±1.8°F

Operating conditions

Nominal flow rates	
S100	220000 kg/h / 8084 lb/min
S150	500000 kg/h / 18372 lb/min
S250	1200000 kg/h / 44092 lb/min
S400	2400000 kg/h / 88185 lb/min
Maximum flow rates	
S100	420000 kg/h / 15432 lb/min
S150	900000 kg/h / 33069 lb/min
S250	2300000 kg/h / 84510 lb/min
S400	4600000 kg/h / 169021 lb/min
Ambient temperature	
Compact version with Aluminium transmitter	-40...+60°C / -40...+140°F
	Extended temperature range: 65°C / 149°F for some I/O options. For more information contact manufacturer.
Compact version with Stainless Steel transmitter	-40...+55°C / -40...+130°F
Remote versions	-40...+65°C / -40...+149°F
Process temperature	
Flanged connection	-45...+130°C / -49...+266°F

Nominal pressure at 20°C / 68°F	
Measuring tube (Duplex UNS S31803)	
PED	-1...150 barg / -14.5...2175 psig
cFMus (S100...250)	-1...140 barg / -14.5...2030 psig
cFMus (S400)	-1...110 barg / -14.5...1595 psig
CRN / ASME B31.3	-1...100 barg / -14.5...1450 psig
Measuring tube (Super Duplex UNS S32760)	
PED	-1...180 barg / -14.5...2610 psig
cFMus	-1...152 barg / -14.5...2205 psig
CRN / ASME B31.3	-1...120 barg / -14.5...1740 psig
Outer cylinder	
Non PED / CRN approved	Typical burst pressure > 100 barg / 1450 psig
PED approved secondary containment	-1...40 barg / -14.5...580 psig (S100...250 only)
	-1...150 barg / -14.5...2175 psig (Duplex option)
Fluid properties	
Permissible physical condition	Liquids, gases, slurries
Permissible gas content (volume)	Contact manufacturer for information.
Permissible solid content (volume)	Contact manufacturer for information.
Protection category	
EN 60529	IP66 / 67
NEMA 250	NEMA 4X
Installation conditions	
Inlet runs	None required
Outlet runs	None required

Materials

Measuring tube	Stainless Steel UNS S31803 (1.4462)
	Optional UNS S32760 (1.4501)
Spigot	Stainless Steel UNS J92205 (1.4470)
	Optional UNS J93404 (1.4469)
Flanges	Stainless Steel AISI 316 / 316L (1.4401 / 1.4404) dual certified
	Optional Stainless Steel UNS S31803 (1.4462) (NACE approved)
	Optional UNS S32760 (1.4501) (NACE approved)
Outer cylinder (S100...250)	Stainless Steel AISI 304 / 304L (1.4301 / 1.4307) dual certified
	Optional Stainless Steel AISI 316 / 316L (1.4401 / 1.4404) dual certified
	Optional Stainless Steel UNS S31803 (1.4462) ①
Outer cylinder (S400)	Standard 9mm wall: Stainless Steel AISI 316 / 316L (1.4401 / 1.4404) dual certified
	Optional 15mm wall: Stainless Steel UNS S31803 (1.4462) (NACE approved)

Heating jacket version	
Heating jacket	Stainless Steel 316L (1.4404)
	Note: the outer cylinder is in contact with the heating medium
Remote versions	
Junction box	Die cast Aluminium (polyurethane coating)

Process connections

Flange	
DIN	DN100...400 / PN16...160
ASME	4...16" / ASME 150...1500
JIS	100A / 10...20K

Electrical connections

Electrical connections	For full details, including: power supply, power consumption etc., see technical data for the relevant Transmitter.
I/O	For full details of I/O options, including data streams and protocols, see technical data for the relevant Transmitter.

Approvals

CE	The device fulfils the statutory requirements of the CE directive. The manufacturer certifies that these requirements have been met by applying the CE mark.
cFMus	Class I, Div 1 groups A, B, C, D
	Class II, Div 1 groups E, F, G
	Class III, Div 1 hazardous areas
	Class I, Div 2 groups A, B, C, D
	Class II, Div 2 groups F, G
	Class III, Div 2 hazardous areas
ANSI / CSA (Dual Seal)	12.27.01-2003
Custody Transfer	Measuring Instruments Directive (MID) MI 002 and MI 005 (most recent and up to date version)
	OIML R117-1
	OIML R137 (pending)
	Compliant with API and AGA
Ingress protection	EN 60529 (most recent and up to date version)
	NEMA 250 (most recent and up to date version)
ATEX (most recent and up to date version)	
CFS400C non Ex i Signal outputs	
Ex d connection compartment	II 1/2 G - Ex db ia IIC T6...T1 Ga/Gb
	II 2 D - Ex tb IIIC T160°C Db
Ex e connection compartment	II 1/2 G - Ex db eb ia IIC T6...T1 Ga/Gb
	II 2 D - Ex tb IIIC T160°C Db

CFS400C Ex i signal outputs	
Ex d connection compartment	II 1/2 (1) G - Ex db ia (ia Ga) IIC T6...T1 Ga/Gb
	II 2 (1) D - Ex tb (ia Da) IIIC T160°C Db
Ex e connection compartment	II 1/2 (1) G - Ex db eb ia (ia Ga) IIC T6...T1 Ga/Gb
	II 2 (1) D - Ex tb (ia Da) IIIC T160°C Db
CFS400A(F)	II 1 G - Ex ia IIC T6...T1 Ga
	II 1 D - Ex ia IIIC T160°C Da

① Where this option is ordered, the electronics stem material is UNS J92205 (1.4470)

6.3 ATEX temperature limits

	Ambient temp. T_{amb} °C	Max medium temp. T_m °C	Temp. class	Max. Surface temp. °C	
CFS400A(F) - with or without heating jacket / insulation	-40...+40	40	T6 - T1	T70	
		55	T5 - T1	T85	
		90	T4 - T1	T120	
		130	T3 - T1	T160	
	-40...+50	55	T5 - T1	T85	
		90	T4 - T1	T120	
		130	T3 - T1	T160	
	-40...+65	65	T5 - T1	T95	
		90	T4 - T1	T120	
		130	T3 - T1	T160	
	Minimum medium temp: -50°C				
	CFS400A(C) – aluminium transmitter housing with or without heating jacket / insulation	-40...+40	40	T6 - T1	T70
55			T5 - T1	T85	
90			T4 - T1	T120	
130			T3 - T1	T160	
-40...+50		55	T5 - T1	T85	
		90	T4 - T1	T120	
		130	T3 - T1	T160	
-40...+60		65	T5 - T1	T95	
		100	T4 - T1	T130	
-40...+65 ①		65	T5 - T1	T95	
Minimum medium temp: -45°C					

CFS400A(C) – SS transmitter housing with or without heating jacket / insulation	-40...+40	40	T6 - T1	T70
		55	T5 - T1	T85
		90	T4 - T1	T120
		130	T3 - T1	T160
	-40...+50	55	T5 - T1	T85
		90	T4 - T1	T120
	-40...+60	60	T5 - T1	T90
	Minimum medium temp: -45°C			

① Depending on I/O option. Please call for more information.

6.4 Maximum end loadings

		S100	S150	S250	S400
Flanges					
20°C	40 barg	150kN	350kN	550kN	750kN
	100 barg	100kN	120kN	60kN	
	150 barg				
	180 barg				
130°C	32 barg	150kN	280kN	400kN	
	80 barg	60kN	50kN	50kN	
	115 barg				
	130 barg				

- These (axial) loads have been calculated, based on 316L schedule 80 process pipework, where un-radiographed butt welds have been used in pipe joints.
- The loads shown are the maximum permitted static load. If loads are cycling (between tension and compression) these loads should be reduced. For advice, consult the manufacturer.
- To prevent damage DO NOT apply loads to the heating jacket connections on the meter. The manufacturer recommends that you use flexible connection pipes.

6.5 Measuring accuracy

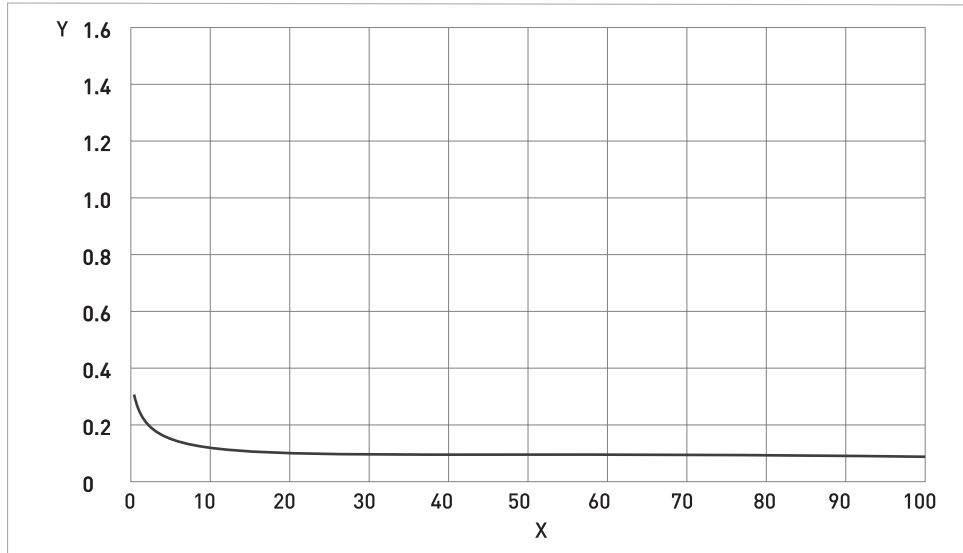

X flow rate [%]
 Y measuring error [%]

Measuring error

The measuring error is obtained from the combined effects of accuracy and zero stability.

Reference conditions

Product	Water
Temperature	+20°C / +68°F
Operating pressure	1 barg / 14.5 psig

6.6 Guidelines for maximum operating pressure

Notes:

- Ensure that the meter is used within its operating limits
- The maximum operating pressure will be either the flange rating or the measuring tube rating, **WHICHEVER IS THE LOWER!**

Pressure / temperature de-rating, all meter sizes in metric (flanged connections as per EN 1092-1:2007)

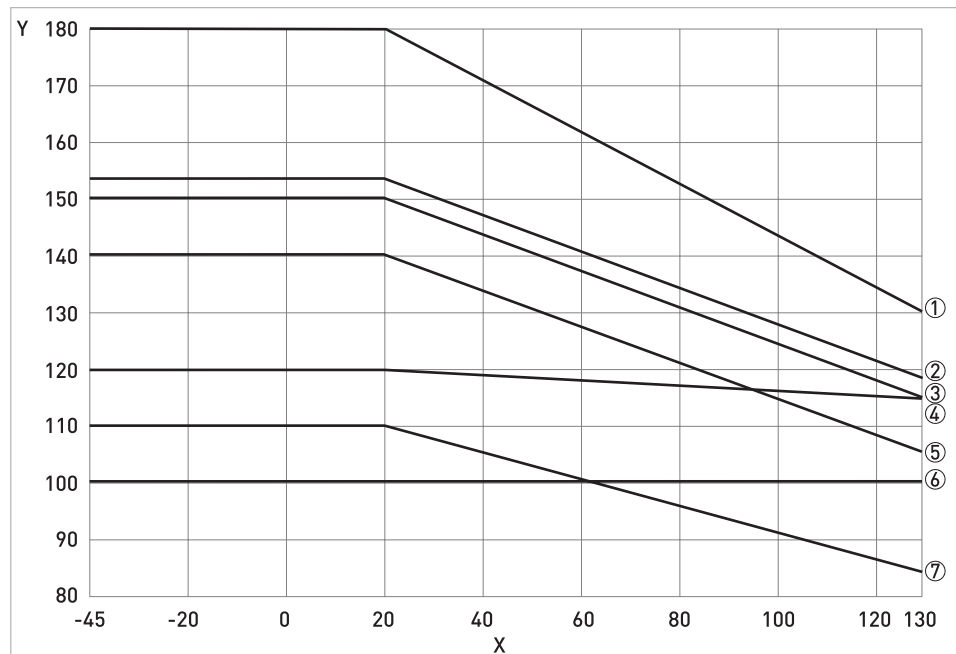

X temperature [°C]

Y pressure [barg]

- ① Measuring tube (UNS S32760) PED certification
- ② Measuring tube (UNS S32760) FM certification
- ③ Measuring tube (UNS S31803) PED certification
- ④ Measuring tube (UNS S32760) CRN certification
- ⑤ Measuring tube (UNS S31803) FM certification (S100...250)
- ⑥ Measuring tube (UNS S31803) CRN certification
- ⑦ Measuring tube (UNS S31803) FM certification (S400)

Linear de-rating of PED certified secondary containment

Outer cylinder material	-45°C	20°C	130°C
304 / L or 316 / L (S100...250)	40 barg	40 barg	32 barg
UNS S31803 (S100...400)	150 barg	150 barg	100 barg

Pressure / temperature de-rating, all meter sizes, in imperial (flanged connections as per ASME B16.5)

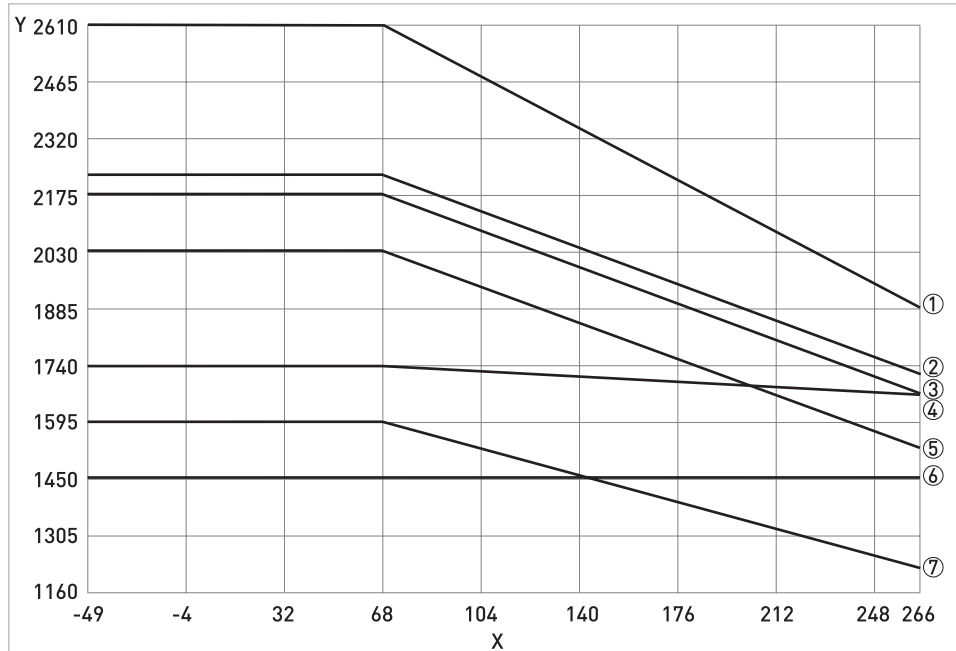

X temperature [°F]
Y pressure [psig]

- ① Measuring tube (UNS S32760) PED certification
- ② Measuring tube (UNS S32760) FM certification
- ③ Measuring tube (UNS S31803) PED certification
- ④ Measuring tube (UNS S32760) CRN certification
- ⑤ Measuring tube (UNS S31803) FM certification (S100...250)
- ⑥ Measuring tube (UNS S31803) CRN certification
- ⑦ Measuring tube (UNS S31803) FM certification (S400)

Linear de-rating of PED certified secondary containment

Outer cylinder material	-49°F	68°F	266°F
304 / L or 316 / L (S100...250)	580 psig	580 psig	464 psig
UNS S31803 (S100...400)	2175 psig	2175 psig	1450 barg

Flanges

- DIN flange ratings are based on EN 1092-1 2007 table G.4.1 material group 14E0
- ASME flange ratings are based on ASME B16.5 2003 table 2 material group 2.2
- JIS flange ratings are based on JIS 2220: 2001 table 1 division 1 material group 022a

6.7 Dimensions and weights

6.7.1 Flanged versions

Meter dimensions

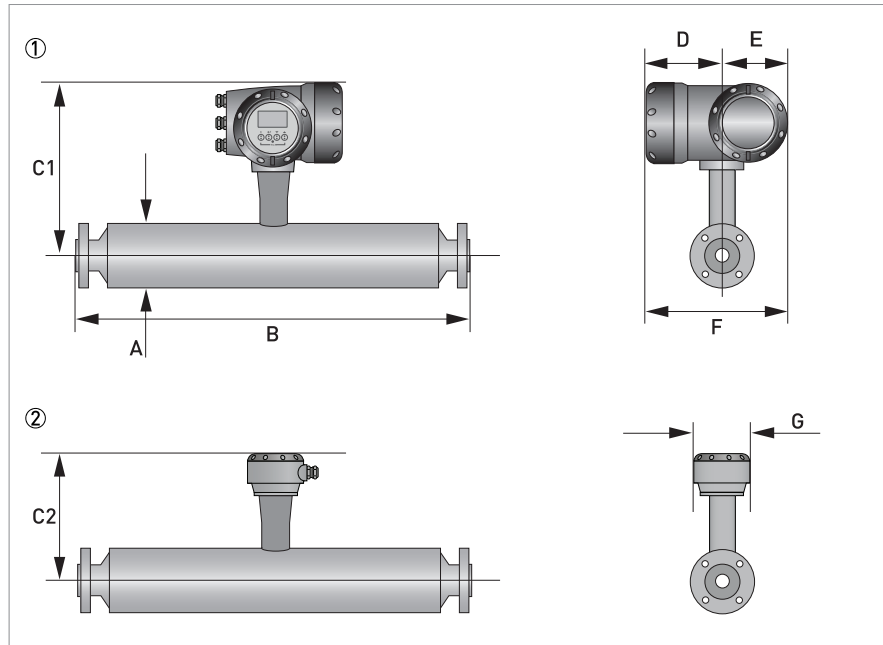

- ① Compact version
② Remote version

Meter weights (PN40 flanges).

	Weight	Compact		Remote	
		Aluminium	Stainless Steel	Aluminium	Stainless Steel
S100	kg	84.8	90.1	80.8	81.7
	lb	187.0	198.0	178.0	180.0
S150	kg	211.5	216.8	207.5	208.4
	lb	466.0	478.0	457.0	459.0
S250	kg	444.5	449.8	440.5	441.4
	lb	980.0	991.0	971.0	973.0
S400 ①	kg	940.0	945.3	936.0	936.9
	lb	2072.3	2083.4	2063.5	2065.5
S400 ②	kg	1045.0	1050.3	1041.0	1041.9
	lb	2303.8	2315.5	2295.0	2297.0

- ① 9mm outer cylinder wall thickness
② 15mm outer cylinder wall thickness

For meter weights with different flange ratings, please contact the manufacturer.

Measuring tube in Stainless Steel

	Dimensions [mm]			
	S100	S150	S250	S400
A	219 ±5	323 ±5	406 ±5	508 ±5
C1 (compact)	370 ±5	422 ±5	463 ±5	516 ±5
C2 (remote)	307 ±5	359 ±5	400 ±5	453 ±5
D	137			
E	123.5			
F	260.5			
G	118			

	Dimensions [inches]			
	S100	S150	S250	S400
A	8.6 ±0.2	12.7 ±0.2	16 ±0.2	20 ±0.2
C1 (compact)	14.6 ±0.2	16.6 ±0.2	18.2 ±0.2	20.3 ±0.2
C2 (remote)	12.1 ±0.2	14.1 ±0.2	15.7 ±0.2	17.8 ±0.2
D	5.4			
E	4.9			
F	10.2			
G	4.6			

Flange connections

	Dimension B [mm]			
	S100	S150	S250	S400
PN16				
DN100	1284	-	-	-
DN150	1290	1584	-	-
DN200	-	1598	-	-
DN250	-	-	1953	-
DN300	-	-	1969	-
DN350	-	-	-	2290
DN400	-	-	-	2296
PN40				
DN100	1310	-	-	-
DN150	1330	1624	-	-
DN200	-	1650	-	-
DN250	-	-	2023	-
DN300	-	-	2043	-

	Dimension B [mm]			
	S100	S150	S250	S400
DN350	-	-	-	2376
DN400	-	-	-	2396
PN63				
DN100	1336	-	-	-
DN150	1370	1664	-	-
DN200	-	1694	-	-
DN250	-	-	2063	-
DN300	-	-	2093	-
DN350	-	-	-	2426
DN400	-	-	-	2446
PN100				
DN100	1360	-	-	-
DN150	1410	1704	-	-
DN200	-	1734	-	-
DN250	-	-	1970	-
DN300	-	-	2153	-
DN350	-	-	-	2504
DN400	-	-	-	2496
PN160				
DN100	1380	-	-	-
DN150	1436	1730	-	-
DN200	-	1754	-	-
DN250	-	-	2123	-
DN300	-	-	2163	-
DN350	-	-	-	2566
DN400	-	-	-	2572
ASME 150				
4"	1334	-	-	-
6"	1358	1652	-	-
8"	-	1678	-	-
10"	-	-	2017	-
12"	-	-	2043	-
14"	-	-	-	2380
16"	-	-	-	2380
ASME 300				
4"	1352	-	-	-
6"	1378	1672	-	-
8"	-	1698	-	-

	Dimension B [mm]			
	S100	S150	S250	S400
10"	-	-	2049	-
12"	-	-	2075	-
14"	-	-	-	2412
16"	-	-	-	2414
ASME 600				
4"	1398	-	-	-
6"	1428	1722	-	-
8"	-	1754	-	-
10"	-	-	2131	-
12"	-	-	2139	-
14"	-	-	-	2470
16"	-	-	-	2496
ASME 900				
4"	1422	-	-	-
6"	1474	1768	-	-
8"	-	1812	-	-
10"	-	-	2195	-
12"	-	-	2227	-
14"	-	-	-	2566
16"	-	-	-	2572
ASME 1500				
4"	1442	-	-	-
6"	1554	-	-	-
8"	-	1914	-	-
10"	-	-	2335	-
12"	-	-	2393	-
14"	-	-	-	2736
16"	-	-	-	2762
JIS 10K				
100A	1270	-	-	-
350A	-	-	-	2284
JIS 20K				
100A	1296	-	-	-
350A	-	-	-	2346

	Dimension B [inches]			
	S100	S150	S250	S400
PN16				
DN100	50.5	-	-	-
DN150	50.8	62.4	-	-
DN200	-	62.9	-	-
DN250	-	-	77.0	-
DN300	-	-	77.5	-
DN350	-	-	-	90.2
DN400	-	-	-	90.4
PN40				
DN100	51.5	-	-	-
DN150	52.4	63.9	-	-
DN200	-	65.0	-	-
DN250	-	-	79.6	-
DN300	-	-	80.4	-
DN350	-	-	-	93.5
DN400	-	-	-	94.3
PN63				
DN100	52.6	-	-	-
DN150	53.9	65.5	-	-
DN200	-	66.7	-	-
DN250	-	-	81.2	-
DN300	-	-	82.4	-
DN350	-	-	-	95.5
DN400	-	-	-	96.3
PN100				
DN100	53.9	-	-	-
DN150	55.5	67.1	-	-
DN200	-	68.3	-	-
DN250	-	-	77.6	-
DN300	-	-	84.8	-
DN350	-	-	-	98.6
DN400	-	-	-	98.3
PN160				
DN100	54.3	-	-	-
DN150	56.5	68.1	-	-
DN200	-	69.0	-	-
DN250	-	-	83.6	-
DN300	-	-	85.1	-

	Dimension B [inches]			
	S100	S150	S250	S400
DN350	-	-	-	101.0
DN400	-	-	-	101.3
ASME 150				
4"	52.5	-	-	-
6"	53.4	65.0	-	-
8"	-	66.1	-	-
10"	-	-	79.4	-
12"	-	-	80.4	-
14"	-	-	-	93.7
16"	-	-	-	93.7
ASME 300				
4"	53.2	-	-	-
6"	54.2	65.8	-	-
8"	-	66.8	-	-
10"	-	-	80.7	-
12"	-	-	81.7	-
14"	-	-	-	95.0
16"	-	-	-	95.0
ASME 600				
4"	55.0	-	-	-
6"	56.2	67.8	-	-
8"	-	69.0	-	-
10"	-	-	83.9	-
12"	-	-	84.2	-
14"	-	-	-	97.2
16"	-	-	-	98.3
ASME 900				
4"	56.0	-	-	-
6"	58.0	69.6	-	-
8"	-	71.3	-	-
10"	-	-	86.4	-
12"	-	-	87.7	-
14"	-	-	-	101.0
16"	-	-	-	101.3
ASME 1500				
4"	56.8	-	-	-
6"	61.2	-	-	-
8"	-	75.3	-	-

	Dimension B [inches]			
	S100	S150	S250	S400
10"	-	-	91.9	-
12"	-	-	94.2	-
14"	-	-	-	107.7
16"	-	-	-	108.7
JIS 10K				
100A	50.0	-	-	-
350A	-	-	-	89.9
JIS 20K				
100A	51.0	-	-	-
350A	-	-	-	92.4

6.7.2 Heating jacket version

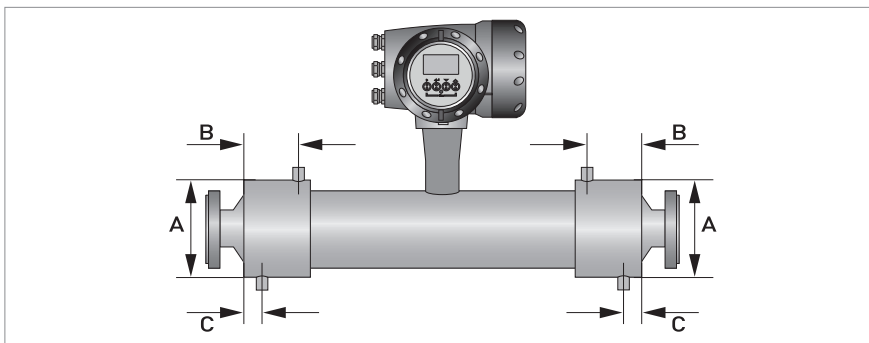

	Dimensions [mm]			
	S100	S150	S250	S400
Heating connection size	25 mm (ERMETO)			
A	254 ±2.5	355 ±2.5	444 ±2.5	545 ±2.5
B	178 ±2.0	228 ±2.0	234 ±2.0	268 ±2.0
C	28 ±2.0	28 ±2.0	32 ±2.0	28 ±2.0

	Dimensions [inches]			
	S100	S150	S250	S400
Heating connection size	1" (NPTF)			
A	10 ±0.1	14 ±0.1	17.5 ±0.1	21.5 ±0.1
B	7 ±0.08	9 ±0.08	9.2 ±0.08	10.5 ±0.08
C	1.1 ±0.08	1.1 ±0.08	1.26 ±0.08	1.1 ±0.08

6.7.3 Purge port option

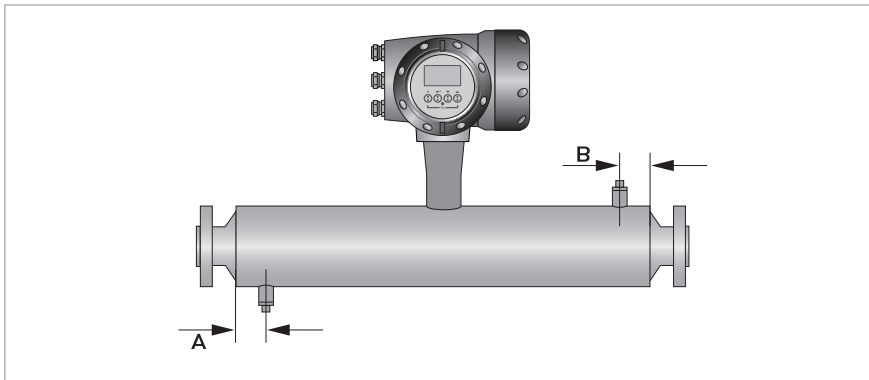

	Dimensions [mm]			
	S100	S150	S250	S400
A	70 ±1.0	100 ±1.0		
B	70 ±1.0	100 ±1.0		

	Dimensions [inches]			
	S100	S150	S250	S400
A	2.75 ±0.04	4.0 ±0.04		
B	2.75 ±0.04	4.0 ±0.04		

Schneider Electric Systems USA, Inc. Global Customer Support
70 Mechanic Street Inside U.S.: 1-866-746-6477
Foxboro MA 02035-2037 Outside U.S.: 1-508 543 8750
United States of America <https://pasupport.schneider-electric.com>
<http://www.se.com>

Copyright 2020 Schneider Electric Systems USA, Inc.
All rights reserved.

The Schneider Electric brand and any trademarks of
Schneider Electric SE or its subsidiaries are the property
of Schneider Electric SE or its subsidiaries.
All other trademarks are the property of their respective
owners.

