

**873 Series Electrochemical Analyzers**  
**pH, ORP, Ion Selective, Contacting Conductivity**  
**Electrodeless Conductivity, Resistivity, and Dissolved Oxygen**



METAL ENCLOSURE VERSION  
MOUNTING HARDWARE NOT SHOWN

METAL ENCLOSURE VERSION  
WITH PIPE MOUNTING HARDWARE  
AND OPTIONAL STORM DOOR



*These small, 1/4 DIN panel size, microprocessor-based analyzers are a family of six instruments which in conjunction with 871 Series Sensors provide measurement, display, and signal transmission of pH, ORP, selective ion concentration, contacting conductivity, electrodeless conductivity, resistivity, or dissolved oxygen concentration in aqueous solutions. Solution temperature is also measured to provide temperature display, transmission, and automatic temperature compensation. A choice of isolated 0 to 20 mA, 4 to 20 mA, or 0 to 10 V dc measurement output signals is offered. A multi-function, front-panel keypad, dedicated to each analyzer type, provides for configuration and operational control.*

**FAMILY OF ANALYZERS – USER FAMILIARITY**

The 873 Series is a true family of six electrochemical analyzers - pH/ORP (PH), contacting conductivity (CC), electrodeless conductivity (EC), resistivity (RS), dissolved oxygen (DO), and the dual pH/ORP/ISE analyzer (DPX). All six instruments share similar front keypads, a common analyzer housing, common mounting hardware, and input/output wiring. In addition, wherever possible, similar

setup and configuration codes are utilized to provide analogous programming procedures for each analyzer type.

873 Series Electrochemical Analyzers are complimentary to the 873A Series. See PSS 6-1C1 F for 873A Analyzer specifications.

*Equipment should be installed, operated, serviced, and maintained only by qualified personnel. No responsibility is assumed by Schneider Electric for any consequences arising from the use of this material.*

### NO BATTERY BACKUP REQUIRED

Non-volatile EEPROM memory is employed to protect all operating parameters and calibration data in the event of power interruptions.

### INSTRUMENT SECURITY CODE

A 4-digit combination code lock, user configurable, provides protection of operational parameters from accidental or unauthorized access.

### DUAL SENSOR INPUT

The contacting conductivity (CC), resistivity (RS), dissolved oxygen (DO), and dual pH/ORP/ISE (DPX) versions are able to accept either one or two sensor inputs. See measurement specific Features and Benefits sections for details.

### ANALOG OUTPUT(S)

All analyzer models with metal housing and all DO analyzers (plastic or metal housing) have two outputs available. All other analyzers with plastic housing have a single output. The outputs are isolated, with span limits continuously adjustable via the keypad to any values within the instrument's entered full scale value. Available output signals are 0 to 10 V dc, 4 to 20 mA dc, and 0 to 20 mA dc (jumper selectable). For units with two output signals, full configurability is available. A few possible combinations include:

- ▶ Conductivity and Temperature
- ▶ pH and Temperature
- ▶ Conductivity Sensor 1 and Conductivity Sensor 2
- ▶ % Rejection and Temperature
- ▶ % Rejection and Conductivity Sensor 1
- ▶ Dissolved Oxygen Sensor 1 and Dissolved Oxygen Sensor 2
- ▶ pH Sensor 1 and pH Sensor 2 (DPX)
- ▶ pH and Fluoride Concentration (DPX)

### DUAL ALARMS

Dual independent, Form C dry alarm contacts, rated 5A noninductive, 125 V ac/30 V dc are provided as a standard feature. When an alarm condition exists, the alarm status is alternately displayed with the measurement on the LED (light-emitting diode) display. Inductive loads can be driven by installing external surge-absorbing devices across the contact terminations.

### HAZARDOUS AREA CLASSIFICATION

The field-mounted, epoxy-painted, cast and extruded aluminum versions are designed to meet the requirements for Class I, Division 2, Groups A, B, C and D hazardous locations. Please contact Global Customer Support for current status of agency approvals.

### FRONT PANEL DISPLAY AND KEYPAD

The instrument's display consists of a four-digit bank of red LEDs with decimal point, and an illuminated legend area to the right of the LEDs. As one of the few instruments in its class using a 14.2 mm (0.56 in) display height, it provides visibility at a distance up to 6 m (20 ft). There are eight backlit legends (mV, pH,  $\mu\text{S}/\text{cm}$ ,  $\text{mS}/\text{cm}$ , ppm, %,  $\mu\text{A}$ ,  $\text{M}\ \Omega\cdot\text{cm}$ ) contingent on Model Type. The digits are clearly visible through a nonreflective, protective window on the front panel.

The measurement value is the normally displayed data. If other data is displayed due to prior keypad operations, the display automatically defaults to the measurement value 10 seconds after the last keypad depression.

If no fault or alarm conditions are detected in the instrument, the measurement value is steadily displayed. If fault or alarm conditions are detected, the display alternates between the measurement value and a fault or alarm message at a 1 second rate.

Each instrument's front panel keypad consists of eight keys. Certain keys are for fixed functions, while other keys are for split functions. The upper function of a split function key is actuated by pressing the shift key in conjunction with the split function key.

## RUGGED 1/4 DIN, METAL FIELD-MOUNTED ENCLOSURE

The metal field-mounted enclosure is suitable for either panel, pipe, or surface mounting. It is constructed of cast and extruded aluminum coated with a tough epoxy-based paint. The enclosure is watertight, dusttight, and corrosion-resistant, meeting requirements of NEMA 4X, CSA ENCL 4X, and IEC IP65. It fits in a 92 x 92 mm (3.6 x 3.6 in) panel cutout (1/4 DIN size). The metal enclosure provides inherent protection against radio frequency interference (RFI) and electromagnetic interference (EMI).

873 Series Analyzers (except 873DPX) are also available in a molded glass-filled Noryl enclosure, which is ideal for panel mounting in non-hazardous locations.

## APPLICATION FLEXIBILITY

The instrument offers application flexibility through its standard software package. The software, run on the internal microprocessor, allows the user to define and set operating parameters particular to his application. These parameters fall into four general categories: Measurement Range, Alarm Configuration, Diagnostics, and Output Characterization. These parameters are retained in the EEPROM nonvolatile memory. Following power interruptions, all operating parameters are maintained.

### Measurement Range

The 873 Analyzer has wide range capability built in. For example, the contacting conductivity analyzer can be configured through the set-up key to measure 17 different ranges from 0 to 1, to 0 to 20,000  $\mu\text{S}/\text{cm}$ . This feature permits a user the ability to stock a single unit and apply it to any measurement range within that technology.

Temperature compensation selection is accessible through the set-up key. The user may select the type of temperature compensation which best satisfies the application. For example, the electrodeless conductivity analyzer offers a host of preprogrammed temperature compensation curves, including such electrolytes as sodium chloride (NaCl), sulfuric acid ( $\text{H}_2\text{SO}_4$ ), sodium hydroxide (NaOH), and several others.

## Alarm Configuration

Each of the two alarms may be configured to the user's requirements. The configurable parameters within the alarms are measurement selection, alarm sense, alarm state, and alarm hysteresis.

Either of the two alarms may be configured to one of several measurement selections. For example, with the pH version, either alarm may be designated as either a pH or a temperature alarm. With the contacting conductivity version, the choices include:

- ▶ Conductivity Sensor 1
- ▶ Conductivity Sensor 2
- ▶ Temperature Sensor 1
- ▶ Temperature Sensor 2
- ▶ Ratio Measurement
- ▶ % Rejection Measurement

Alarm sense defines normal operation and activation of alarms on deviation from normal measurement. Alarms may be selected as low/high, low/low, and high/high.

Alarm state is selectable allowing for either activation of relays when instrument goes from normal measurement to alarm state, or relay activation when instrument goes from alarm to normal operation (fail safe).

Alarm hysteresis is selectable for each alarm. Hysteresis may be set for 0 to 99% of full scale measurement. With the selection of the alarm hysteresis, the dead band around the trip point can be adjusted to provide a control variable.

On/Off Control with Lag is accomplished using trigger, feed, and delay timers. Three timers are supplied for each alarm as standard, and they are settable from 0 to 99.99 minutes in increments of 0.01 minutes. The trigger timer prevents the alarm from triggering unless the measurement remains in an alarm state for a user-defined period of time. The feed timer keeps the alarm ON regardless of what the measurement value is in relation to set point. Upon timeout of the feed timer, the delay timer activates and shuts the alarm OFF (to allow for mixing, reacting, etc.) regardless of what the measurement value is in relation to set point.

Upon timeout of the delay timer, the instrument reverts to a normal RUN mode. If the measurement is still in alarm, the feed/delay sequence repeats itself. An adjustable trigger timer is also available to prevent premature triggering of an alarm due to transitory process upset conditions.

Additionally, alternative to a measurement alarm, either alarm can be designated as either an instrument error or a hold alarm. As an error alarm, the alarm can be used as a watchdog timer alarm or as a diagnostic alarm (see “Diagnostics” section below). As a hold alarm, the alarm can be used to alert a remote operator that the analyzer has been put into the output hold mode.

### Extensive Diagnostics

Built-in self tests continuously monitor the instrument's operation. Upon initial power-up, the instrument undergoes an initialization process that performs checksum tests on the PROM and EEPROM memories, a read/write test, an A/D test, and an interrupt input test. Variations of these tests are performed continuously as background tasks as part of the normal operating function.

A software watchdog timer in the microprocessor continuously monitors the activity of the instrument's software. A 1-second timeout time is set in the watchdog timer during initialization. Subsequently, the software must reset the time at a rate less than the timeout time in order to prevent a RESET from occurring. If RESET occurs, the instrument undergoes a restart as it does during power-up. If the fault persists, the instrument does not attain normal operation. In this situation, the software version code is frequently displayed, thus indicating watchdog timeout.

A voltage level detector constantly monitors the microprocessor's +5 V dc power. When the microprocessor's voltage drops below the normal operating level, the RESET is activated. If the level remains below normal, the microprocessor will not restart. If the level goes above and below the normal level, the microprocessor attempts to restart, likewise displaying the software version code.

The operator can define solution temperature and measurement limits within which the instrument is expected to function. These establish valid operational boundaries for the instrument that, if exceeded, are interpreted as a sensor fault.

Dynamic temperature and measurement readings are constantly compared against these limits to ensure that they dwell within the user-defined boundaries.

Any of the fault conditions explained in this section can be remotely communicated through the use of either relay. In addition, either alarm can be used as a “power-loss” indicator by configuring the relay in the normally energized (fail-safe) mode.

### Output Characterization

The 873 Analyzer provides isolated, jumper-selectable, 4 to 20 mA dc, 0 to 20 mA dc or 0 to 10 V dc outputs proportional to the measurement, temperature, or some calculated value (such as ratio, difference, average, or % rejection). Output signals may be configured to be either normal or reverse acting. The output signal may be spanned over any portion of the measurement range. An example of the use of this feature is a pH unit monitoring 0 to 14 pH. The output may be spanned for example, such that 6 pH equals 4 mA dc, and 9 pH equals 20 mA dc, providing greater readability and control on auxiliary recorders and controllers.

With the metal enclosure instrument, the two analog outputs may both be chosen to track a single input, yet spanned differently. For example, one analog output may correspond to 0 to 14 pH (e.g. for recording), while the other analog output may correspond to 6 to 8 pH for tighter control.

Output damping is provided, thus a noisy measurement signal is smoothed out to offer, for example, less tripping of alarms.

## COMPATIBLE SENSORS

The following sensors are compatible with the 873A Analyzer:

- ▶ 871PH Series pH Sensors
- ▶ 871A Series pH Sensors
- ▶ AS100 Series pH Sensors
- ▶ 871EC Series Sensors for Electrodeless Conductivity
- ▶ 871CC Series Sensors for Contacting Conductivity and Resistivity
- ▶ 871FT Series Toroidal Flow-Through Conductivity Sensors
- ▶ 871DO Series Dissolved Oxygen Sensors

*Figure 1. Sensors and Sensor Mounting Accessories*

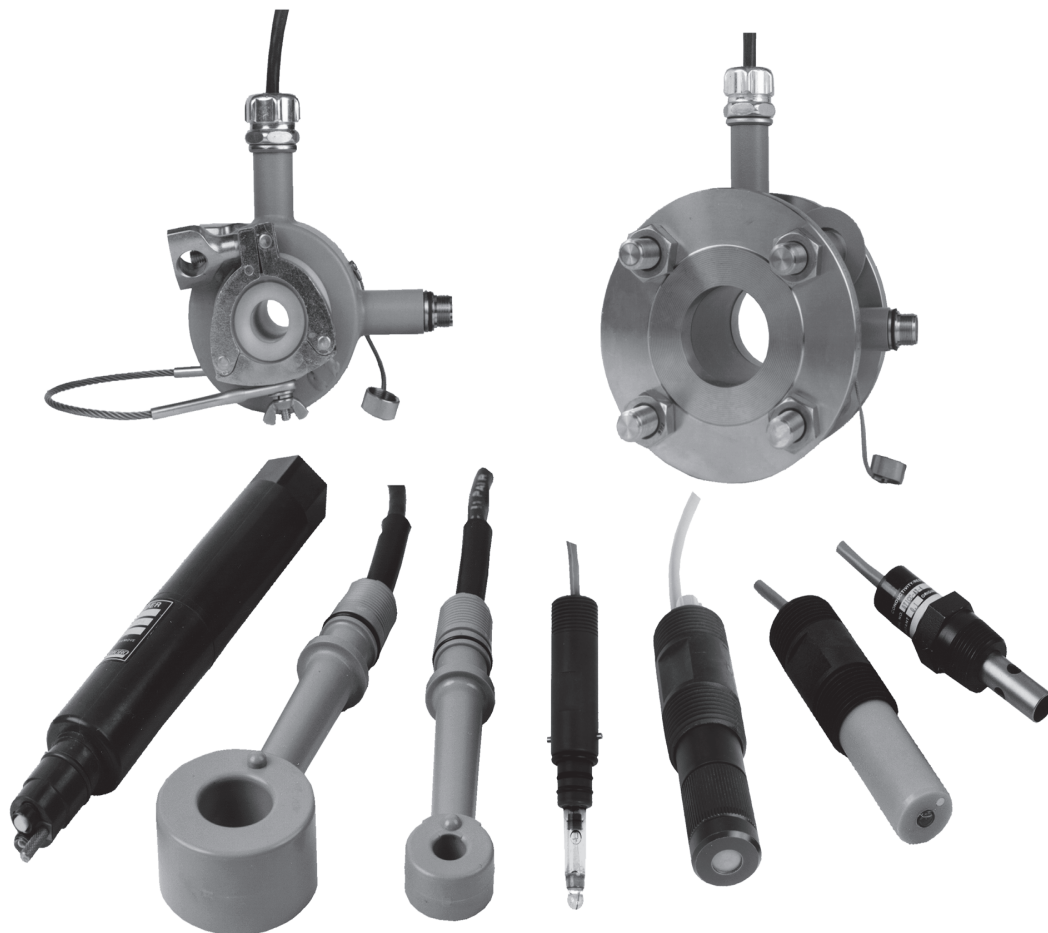

## 873PH PH/ORP ANALYZER FEATURES AND BENEFITS

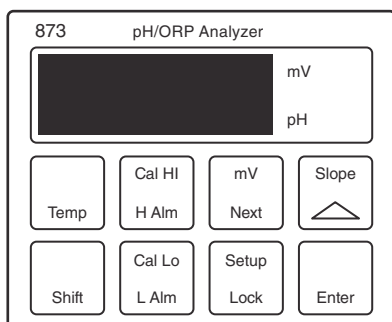

### INTEGRAL PREAMPLIFIER

The 873PH Analyzer contains an integral preamplifier, making it compatible with either high impedance or preamplified sensor inputs.

### DEDICATED SLOPE AND MILLIVOLT DISPLAYS

A single keystroke combination allows the user to display the Nernst slope (mV per pH unit at 25°C) determined by the last 2 point calibration, as well as the absolute voltage generated by the sensor. This feature aids troubleshooting by providing information about the health of the sensor and the validity of the calibration.

### PURE WATER TEMPERATURE COMPENSATION FOR AMMONIA COMPOSITION

A special type of temperature compensation is available for glass electrodes in water samples with traces of ammonia. This feature corrects for the effects of temperature on water/ammonia samples, calculating the pH value of the solution at 25°C.

## INSTRUMENT SPECIFICATIONS

*(For general 873 Analyzer specifications, see 873 ANALYZER - COMMON SPECIFICATIONS on page 25)*

### Measurement Range

-2 to +16 pH (pH measurement)  
-999 to +1400 mV (ORP measurement)

### Units of Measure

pH or mV

### Display Resolution

-2.00 to +16.00 pH (pH measurement)  
-999 to +1400 mV (ORP measurement)

### Temperature Compensation

Adjusts the Nernst slope factor to correct for the variation of the measuring electrode's potential with temperature. Thus, the displayed pH is the actual pH of the solution at process temperature. No temperature compensation is applied to ORP.

### Temperature Compensation Range

-5 to +105°C (23 to 221°F) for pH

### Required Temperature Compensation Element

100 Ω Platinum RTD

### Sensor Cable Length

152 m (500 ft) maximum (preamplified sensor)  
15 m (50 ft) maximum (non-preamplified sensor)

### Analog Output Selections

pH, ORP, or Temperature

### Ambient Temperature Effect

±0.2 mV/°C under normal operating conditions

### Accuracy

#### ANALOG OUTPUTS

±0.25% of Upper Range Limit

#### DIGITAL DISPLAY

±0.1% of Upper Range Limit

### Input Impedance

10<sup>12</sup> Ω minimum; for use with or without external preamplifier; screen (shield) drive provided

### Preamplifier Power

±6.4 V dc at 10 mA, regulated

MODEL CODE

pH/ORP Electrochemical Analyzer

Description	Model
pH/ORP Electrochemical Analyzer	873PH
Supply Voltage and Frequency	
120 V ac, 50/60 Hz	-A
220 V ac, 50/60 Hz	-B
240 V ac, 50/60 Hz	-C
24 V ac, 50/60 Hz	-E
100 V ac, 50/60 Hz	-J
Measurement Output	
0 to 20 mA dc, Isolated	E
4 to 20 mA dc, Isolated	I
0 to 10 V dc, Isolated	T
Enclosure	
Plastic, Panel Mounting, Ordinary Locations Only	P
Field, Metal, Panel Mounting	W
Field, Metal, Surface Mounting - Fixed	X
Field, Metal, Pipe Mounting	Y
Field, Metal, Surface Mounting - Movable	Z
<b>Electrical Certification</b> (see Product Safety Specifications Section)	
CSA, Ordinary Locations, Except 220 and 240 V ac Options	CGZ
CSA, Division 2, Except 220 and 240 V ac Options. Metal Enclosure Only.	CNZ
FM, Ordinary Locations	FGZ
FM, Nonincendive, Division 2	FNZ
Optional Selections	
Storm Door	-7
Special per Engineering Order	-0
Example: 873PH-AIWFNZ-7	

WIRING DIAGRAM OF 873PH ELECTROCHEMICAL ANALYZERS (SEE MI 611-165)

WITH PLASTIC ENCLOSURE

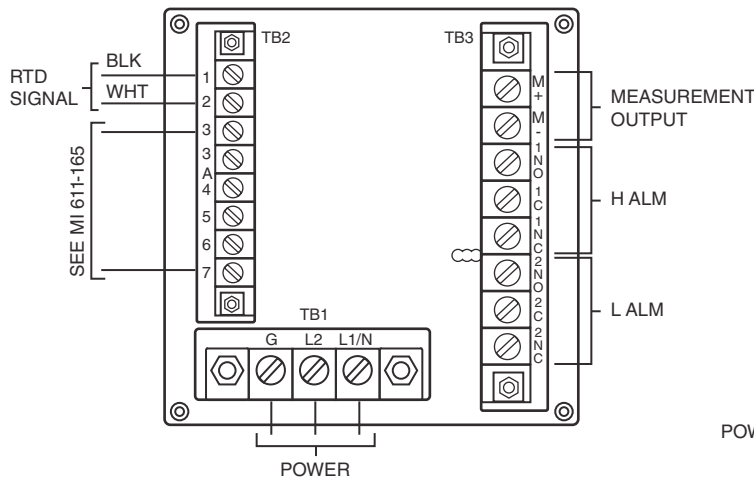

WITH METAL ENCLOSURE

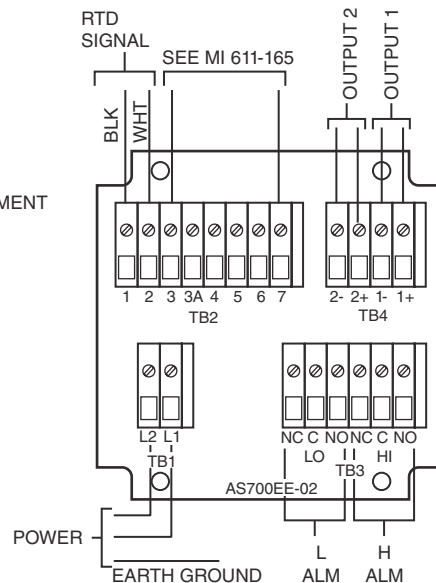

## 873EC ELECTRODELESS CONDUCTIVITY ANALYZER FEATURES AND BENEFITS

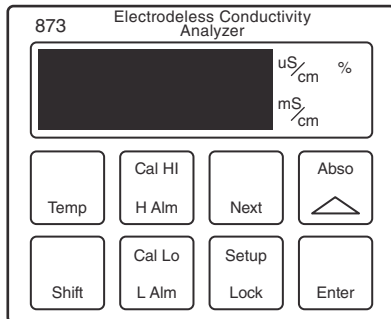
**CONDUCTIVITY OR CONCENTRATION**

The 873EC can be configured to read  $\mu\text{S}/\text{cm}$ ,  $\text{mS}/\text{cm}$ , or % concentration. A series of preprogrammed temperature compensation and % concentration curves are available as a standard feature, allowing for the measurement of conductivity or concentration.

**CHEMICAL CONCENTRATION CONTROL**

On/Off Control of chemical concentration can be accomplished by using alarms with feed and delay timers. Noncontacting sensors provide reliable chemical concentration measurement, saving money by minimizing chemical waste.

**CURVE GENERATION PROGRAM**

The 873EC's processor has an optional program for the generation of nonstandard temperature compensation and/or % concentration curves for specific chemicals. This allows for special measurements in the field. This program can be used at any time to provide more accurate or application specific measurements.

**HIGH SENSITIVITY EC**

When the 873EC is used with Foxboro high sensitivity PEEK sensor, solution conductivity as low as  $5 \mu\text{S}/\text{cm}$  can be accurately measured. EC sensors can then replace contacting sensors, reducing sensor fouling and maintenance.



**INSTRUMENT SPECIFICATIONS**

*(For general 873 Analyzer specifications, see 873 ANALYZER - COMMON SPECIFICATIONS on page 25)*

**Measurement Range**

50, 100, 200 and 500  $\mu\text{S/cm}$

1, 2, 5, 10, 20, 50, 100, 200, 500, 1000, and 2000  $\text{mS/cm}$ . See "Temperature Compensation Curves" below for chemical concentration ranges.

**Temperature Compensation Curves**

NaCl, dilute @ 25°C

NaCl, 0-25% @ 25°C

H<sub>3</sub>PO<sub>4</sub>, 0-35% @ 25°C

HCl, 0-15% @ 25°C

H<sub>2</sub>SO<sub>4</sub>, 0-25% @ 25°C

H<sub>2</sub>SO<sub>4</sub>, 99.5-93% @ 50°C

Oleum, 42-18% @ 65°C

HNO<sub>3</sub>, 0-10% @ 25°C

NaOH, 0-15% @ 25°C

NaOH, 0-20% @ 100°C

Kraft Green Liquor @ 85°C

Kraft Black Liquor @ 160°C

**Units of Measure**

$\mu\text{S/cm}$ ,  $\text{mS/cm}$ , %

**Display Resolution**

0.000 to 999.9  $\mu\text{S/cm}$  or 0.000 to 2000  $\text{mS/cm}$

**Required Temperature Compensation Element**

100  $\Omega$  Platinum RTD or 100 K $\Omega$  Thermistor

**Sensor Cable Length**

30.5 meters (100 feet) maximum

**Analog Output Selections**

Conductivity, Temperature, Log of Conductivity, or % Concentration

**Ambient Temperature Effect**

$\pm 0.15\%$  of Upper Range Limit/ $^{\circ}\text{C}$  under normal operating conditions

**Accuracy****ANALOG OUTPUTS**

$\pm 0.5\%$  of Upper Range Limit

**DIGITAL DISPLAY**

$\pm 0.5\%$  of Upper Range Limit

MODEL CODE

Electrodeless Conductivity Electrochemical Analyzer

Description	Model
Electrodeless Conductivity Electrochemical Analyzer	873EC
Supply Voltage and Frequency	
120 V ac, 50/60 Hz	-A
220 V ac, 50/60 Hz	-B
240 V ac, 50/60 Hz	-C
24 V ac, 50/60 Hz	-E
100 V ac, 50/60 Hz	-J
Measurement Output	
0 to 20 mA dc, Isolated	E
4 to 20 mA dc, Isolated	I
0 to 10 V dc, Isolated	T
Enclosure	
Plastic, Panel Mounting, Ordinary Locations Only	P
Field, Metal, Panel Mounting	W
Field, Metal, Surface Mounting - Fixed	X
Field, Metal, Pipe Mounting	Y
Field, Metal, Surface Mounting - Movable	Z
<b>Electrical Certification</b> (see Product Safety Specifications Section)	
CSA, Ordinary Locations, Except 220 and 240 V ac Options	CGZ
CSA, Division 2, Except 220 and 240 V ac Options. Metal Enclosure Only.	CNZ
FM, Ordinary Locations	FGZ
FM, Nonincendive, Division 2 Locations	FNZ
Optional Selections	
Curve Generation Program	-5
Storm Door	-7
Special per Engineering Order	-0
Example: 873EC-AIYFNZ-57	

WIRING DIAGRAM OF 873EC ELECTROCHEMICAL ANALYZERS

(see MI 611-167)

WITH PLASTIC ENCLOSURE

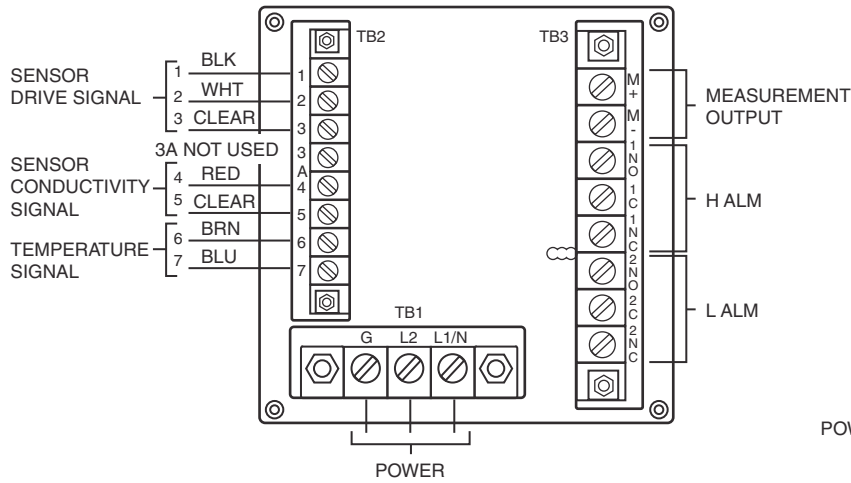

WITH METAL ENCLOSURE

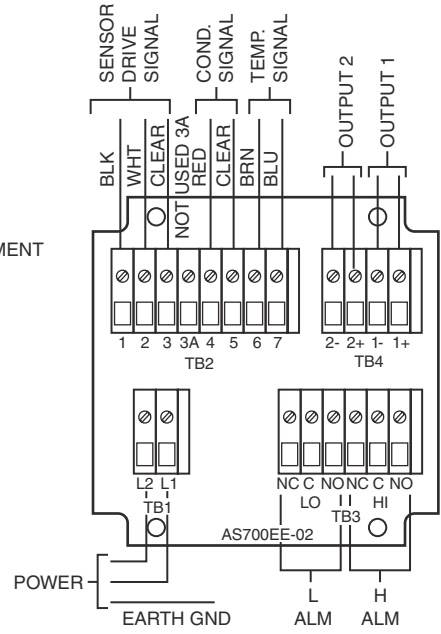

## 873CC CONTACTING CONDUCTIVITY ANALYZER FEATURES AND BENEFITS

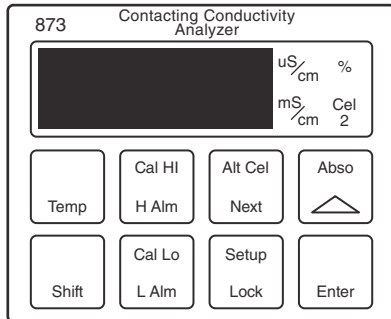

### CURVE GENERATION PROGRAM

The 873CC's processor has an optional program for generating nonstandard temperature compensation and % concentration curves for specific chemicals. This allows special measurements in the field. This program can be used at any time to provide more accurate or application specific measurements.

### PROGRAMMABLE CELL FACTORS

Each 871CC Conductivity Sensor of nominal  $0.1 \text{ cm}^{-1}$  cell factor is factory tested and labeled with the actual cell factor data, and with the actual temperature response at  $25^{\circ}\text{C}$ . The 873CC Analyzer can be programmed with these values so that the analyzer can be specifically calibrated with that sensor's cell factor and temperature response. This feature ensures the highest possible accuracy. It also allows for the flexibility of changing the cell factor in the field.

### DUAL SENSOR INPUTS

The 873CC has the capability to be separately calibrated for, and to accept input from, one or two independent sensors. The analyzer can then be configured to measure either in conductivity units ( $\mu\text{S}/\text{cm}$  or  $\text{mS}/\text{cm}$ ) or it can report % ratio or % rejection.

## INSTRUMENT SPECIFICATIONS

*(For general 873 Analyzer specifications, see 873 ANALYZER - COMMON SPECIFICATIONS on page 25)*

**Measurement Range**

1, 2, 5, 10, 20, 50, 100, 200, and 500  $\mu\text{S}/\text{cm}$

0.1, 0.2, 0.5, 1, 2, 5, 10, 20  $\text{mS}/\text{cm}$

0-99% ratio

0-99% rejection

**Units of Measure**

$\mu\text{S}/\text{cm}$ ,  $\text{mS}/\text{cm}$ , %

**Display Resolution**

0.000 to 999.9  $\mu\text{S}/\text{cm}$

0.000 to 20.00  $\text{mS}/\text{cm}$

**Temperature Compensation**

Dilute NaCl solution with water subtraction  
referenced to 25°C

**Temperature Compensation Range**

-5 to +121°C (0 to 250°F) for 100  $\text{K}\Omega$  thermistor

0 to 199°C (32 to 390°F) for 100  $\Omega$  RTD

Sensor Cable Length

152 meters (500 feet) maximum

**Analog Output Selections**

Conductivity Sensor 1 and/or 2, Temperature  
Sensor 1 and/or 2, % Rejection, or Log of  
Conductivity Sensor 1 and/or 2

**Ambient Temperature Effect**

$\pm 0.05\%$  of Upper Range Limit/°C under normal  
operating conditions

**Required Cell Factor**

0.1  $\text{cm}^{-1}$  (for ranges of 1 through 200  $\mu\text{S}/\text{cm}$ )

10  $\text{cm}^{-1}$  (for ranges of 0.2 through 20  $\text{mS}/\text{cm}$ )

**NOTE**

For applications where the dual sensor  
input feature is used, both sensors must  
have the same cell factor.

**Accuracy****ANALOG OUTPUTS**

$\pm 0.5\%$  of Upper Range Limit

**DIGITAL DISPLAY**

$\pm 0.5\%$  of Upper Range Limit

MODEL CODE

Contacting Conductivity Electrochemical Analyzer

Description	Model
Contacting Conductivity Electrochemical Analyzer	873CC
Supply Voltage and Frequency	
120 V ac, 50/60 Hz	-A
220 V ac, 50/60 Hz	-B
240 V ac, 50/60 Hz	-C
24 V ac, 50/60 Hz	-E
100 V ac, 50/60 Hz	-J
Measurement Output	
0 to 20 mA dc, Isolated	E
4 to 20 mA dc, Isolated	I
0 to 10 V dc, Isolated	T
Enclosure	
Plastic, Panel Mounting, Ordinary Locations Only	P
Field, Metal, Panel Mounting	W
Field, Metal, Surface Mounting - Fixed	X
Field, Metal, Pipe Mounting	Y
Field, Metal, Surface Mounting - Movable	Z
<b>Electrical Certification</b> (see Product Safety Specifications Section)	
CSA, Ordinary Locations, Except 220 and 240 V ac Options	CGZ
CSA, Division 2, Except 220 and 240 V ac Options. Metal Enclosure Only.	CNZ
FM, Ordinary Locations	FGZ
FM, Nonincendive, Division 2 Locations	FNZ
Optional Selections	
Curve Generation Program	-5
Storm Door	-7
Special per Engineering Order	-0
Example: 873CC-AIPFGZ-7	

**WIRING DIAGRAM OF 873CC ELECTROCHEMICAL ANALYZERS**

(see MI 611-166)

WITH PLASTIC ENCLOSURE

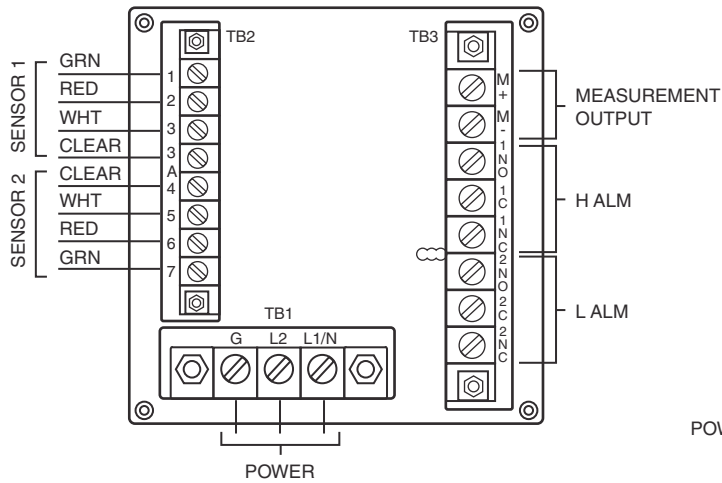

WITH METAL ENCLOSURE

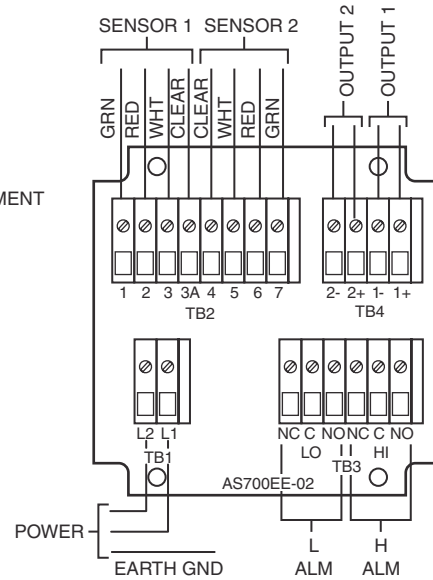

## 873RS RESISTIVITY ANALYZER FEATURES AND BENEFITS

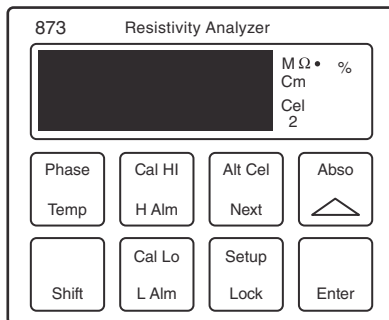
**DUAL SENSOR INPUTS**

The 873RS has the capability to accept input from one or two separate sensors. The analyzer can then be configured to measure either the resistivity units ( $M\Omega \cdot cm$ ) or it can report the ratio of the two sensors. For reverse osmosis applications, the 873RS can also calculate rejection.

**PROGRAMMABLE CELL FACTORS**

Each 871CC Resistivity Sensor is factory tested and labeled with the actual cell factor correct to four decimal places, and with the actual temperature response at 25°C. The 873RS Analyzer can be programmed with these values so that the analyzer can be specially calibrated with that sensor's cell factor and temperature response. This feature ensures the highest possible accuracy, and also allows for the flexibility of changing the cell factor in the field.

**ABSOLUTE RESISTIVITY VIA KEYPAD**

A single keystroke combination allows the user to view uncompensated resistivity data, providing useful diagnostic information and greatly simplifying troubleshooting efforts.



## INSTRUMENT SPECIFICATIONS

*(For general 873 Analyzer specifications, see 873 ANALYZER - COMMON SPECIFICATIONS on page 25)*

**Measurement Range**0 to 2, 5, 10, 15, and 20 M $\Omega$ •cm

0-99% ratio

0-99% rejection

**Units of Measure**M $\Omega$ •cm, %**Display Resolution**0.000 to 2.000 M $\Omega$ •cm00.00 to 20.00 M $\Omega$ •cm**Temperature Compensation**

Ultrapure water temperature correction referenced to 25°C (treated as a dilute NaCl curve)

**Temperature Compensation Range**

0 to 120°C (32 to 248°F)

**Required Temperature Compensation Element**100  $\Omega$  RTD or 100 K $\Omega$  Thermistor**Sensor Cable Length**

152 meters (500 feet) maximum

**Analog Output Selections**

Resistivity Sensor 1 and/or 2, Temperature Sensor 1 and/or 2, Ratio, % Rejection, Log of Resistivity Sensor 1 and/or 2

**Ambient Temperature Effect** $\pm 0.05\%$  of Upper Range Limit/°C under normal operating conditions**Required Cell Factor**0.1 cm<sup>-1</sup>**Accuracy****ANALOG OUTPUTS** $\pm 0.5\%$  of Upper Range Limit**DIGITAL DISPLAY** $\pm 0.5\%$  of Upper Range Limit**NOTE**

For best system accuracy at elevated temperatures, use RTD input sensors.

WIRING DIAGRAM OF 873RS ELECTROCHEMICAL ANALYZERS

(see MI 611-168)

WITH PLASTIC ENCLOSURE

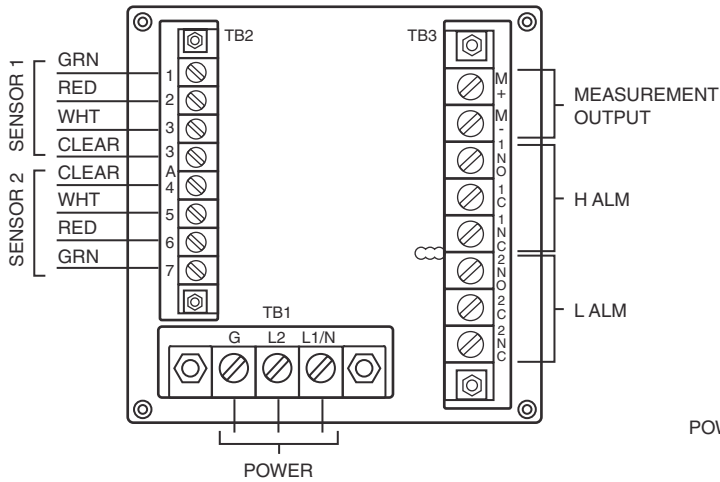

WITH METAL ENCLOSURE

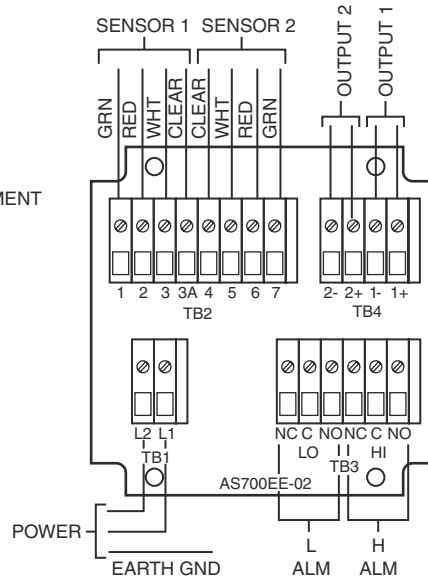

**873DO DISSOLVED OXYGEN ANALYZER FEATURES AND BENEFITS**

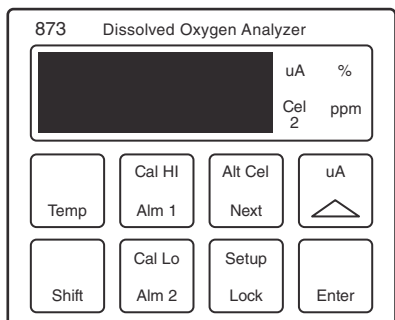

**DUAL SENSOR INPUTS**

The 873DO has the capability to accept input from one or two separate sensors. The analyzer can then be configured to measure either in concentration units (ppm, % saturation, % oxygen in air) or it can report the ratio or difference of the two sensors.

**SENSOR DIAGNOSTICS**

When used with the Foxboro 871DO-C Sensor, the 873DO offers several sensor diagnostic features. The analyzer periodically monitors the sensor for membrane fouling, membrane breakage, and loss of internal filling solution. Mnemonic error messages appear on the display and alternate with the measurement value at a one second rate. These diagnostics alert the user of common sensor problems, reducing preventive maintenance and downtime.

**AMBIENT AIR CALIBRATION**

The calibration procedure for the 873DO Analyzer is performed by simply placing the sensor in ambient air, which is 100% saturated with oxygen.

**INSTRUMENT SPECIFICATIONS**

*(For general 873 Analyzer specifications, see 873 ANALYZER - COMMON SPECIFICATIONS on page 25)*

**Measurement Range**

- 0-5 ppm up to 0-100 ppm
- 0-100, no units
- 0-100% saturation
- 0-25% oxygen in air
- 0-99% ratio

**Units of Measure**

ppm, %

**Display Resolution**

- 0.0 to 100.0 ppm
- 0.0 to 100.0%

**Temperature Compensation**

Automatic for solubility and membrane effects

**Temperature Compensation Range**

0 to 50°C (32 to 120°F)

**Required Temperature Compensation Element**

100 KΩ Thermistor

**Sensor Cable Length**

152 meters (500 feet) maximum

**Analog Output Selections**

DO Sensor 1 and/or 2, Temperature Sensor 1 and/or 2, Difference, Ratio

**Ambient Temperature Effect**

±0.05% of Upper Range Limit/°C under normal operating conditions

**Accuracy**

**ANALOG OUTPUTS**

±0.5% of Upper Range Limit

**DIGITAL DISPLAY**

±0.5% of Upper Range Limit

MODEL CODE

Dissolved Oxygen Electrochemical Analyzer

Description	Model
Dissolved Oxygen Analyzer	873DO
Supply Voltage and Frequency	
120 V ac, 50/60 Hz	-A
220 V ac, 50/60 Hz	-B
240 V ac, 50/60 Hz	-C
24 V ac, 50/60 Hz	-E
100 V ac, 50/60 Hz	-J
Measurement Output	
0 to 20 mA dc, Isolated	E
4 to 20 mA dc, Isolated	I
0 to 10 V dc, Isolated	T
Enclosure	
Plastic, Panel Mounting, Ordinary Locations Only	P
Field, Metal, Panel Mounting	W
Field, Metal, Surface Mounting - Fixed	X
Field, Metal, Pipe Mounting	Y
Field, Metal, Surface Mounting - Movable	Z
<b>Electrical Certification</b> (see Product Safety Specifications Section)	
CSA, Ordinary Locations, Except 220 and 240 V ac Options	CGZ
CSA, Division 2, Except 220 and 240 V ac Options. Metal Enclosure Only.	CNZ
FM, Ordinary Locations	FGZ
FM, Nonincendive, Division 2 Locations	FNZ
Optional Selections	
Rear Cover Terminal Strips for Sensor Connection	-3
Storm Door	-7
Special per Engineering Order	-0
Example: 873DO-AIYFNZ	

WIRING DIAGRAM OF 873DO DISSOLVED OXYGEN ANALYZERS

(see MI 611-169)

WITH PLASTIC ENCLOSURE

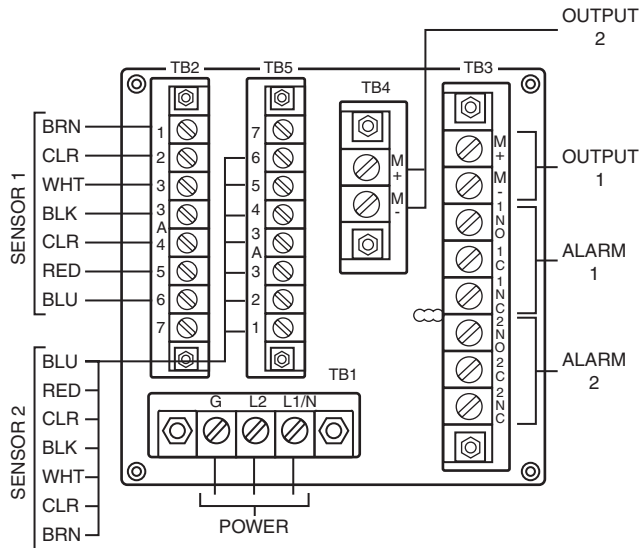

WITH METAL ENCLOSURE

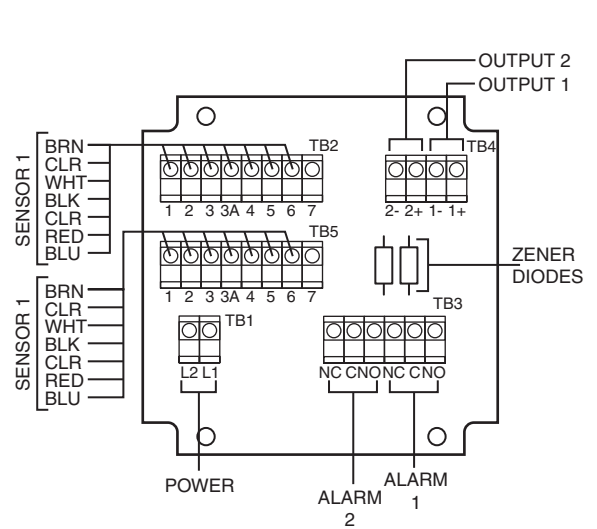

## 873DPX DUAL PH/ORP/ISE ANALYZER FEATURES AND BENEFITS

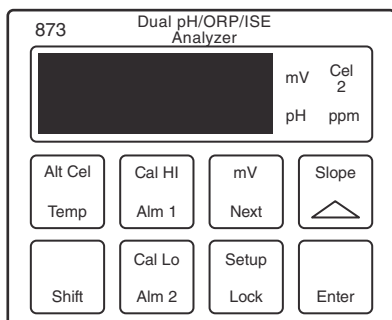

### DUAL SENSOR INPUT

The 873DPX Analyzer is an enhanced version of the 873PH Analyzer. A single 873DPX Analyzer can accept inputs from two independent sensors. With simultaneous measurements, one sensor can act as a backup for the primary sensor, two sensors from different locations can be processed by a common analyzer, or two different measurements (e.g., pH and ORP) can be made at the same time by the same analyzer.

### ION SELECTIVE CAPABILITY

The 873DPX also features a new measurement in addition to pH and ORP: ion-selective electrode or ISE measurement. Using dual sensor inputs, this capability allows for pH correction of ion-selective measurements such as fluoride, to compensate for the effect of pH on free ion activity.

### CUSTOM TEMPERATURE COMPENSATION AND PPM CALIBRATION CURVES

This feature allows the user to program the analyzer with custom temperature compensation curves. Solutions which exhibit non-ideal behavior with changes in temperature can be characterized and process-specific temperature compensation can be applied. This program also allows for custom ppm curves to correct for interferences or non-ideal ISE behavior.

## INSTRUMENT SPECIFICATIONS

*(For general 873 Analyzer specifications, see 873 ANALYZER - COMMON SPECIFICATIONS on page 25)*

**Measurement Range**

-2 to +16 pH (pH measurement)  
-999 to +1400 mV (ORP measurement)  
300 mV span with range limits of -999 and +1000 mV (ISE measurement, displayed as ppm)

**Units of Measure**

pH, ppm, or mV

**Display Resolution**

-2.00 to +16.00 pH (pH measurement)  
-999 to +1400 mV (ORP measurement)  
0 to 2.000 thru 0 to 2000 ppm (ISE measurement)

**Temperature Compensation**

Adjusts the Nernst slope factor to correct for the variation of the measuring electrode's potential with temperature. Thus, the displayed pH is the actual pH of the solution at process temperature. No temperature compensation is applied to ORP.

**Temperature Compensation Range**

-5 to +105°C (23 to 221°F) for pH or ISE only

**Input Impedance**

10<sup>12</sup> Ω minimum on all inputs; for use with or without external preamplifier; screen (shield) drive provided

**Sensor Cable Length**

152 m (500 ft) maximum (preamplified sensor)  
15 m (50 ft) maximum (non-preamplified sensor)

**Analog Output Selections**

pH/ORP/ISE Sensor 1 and/or 2, Temperature Sensor 1 and/or 2, Average, Ratio, or Difference

**Ambient Temperature Effect**

±0.2 mV/°C under normal operating conditions

**Accuracy****ANALOG OUTPUTS**

±0.25% of Upper Range Limit

**DIGITAL DISPLAY**

±0.1% of Upper Range Limit

**Required Temperature Compensation Element**

100 Ω Platinum RTD

**Preamplifier Power**

±6.8 V dc at 10 mA, regulated

MODEL CODE

Dual pH/ORP/ISE Electrochemical Analyzer

Description	Model
Dual pH/ORP/ISE Electrochemical Analyzer	873DPX
Supply Voltage and Frequency	
120 V ac, 50/60 Hz	-A
220 V ac, 50/60 Hz	-B
240 V ac, 50/60 Hz	-C
24 V ac, 50/60 Hz	-E
100 V ac, 50/60 Hz	-J
Measurement Output	
0 to 20 mA dc, Isolated	E
4 to 20 mA dc, Isolated	I
0 to 10 V dc, Isolated	T
Enclosure	
Field, Metal, Panel Mounting	W
Field, Metal, Surface Mounting - Fixed	X
Field, Metal, Pipe Mounting	Y
Field, Metal, Surface Mounting - Movable	Z
<b>Electrical Certification</b> (see Product Safety Specifications Section)	
CSA, Ordinary Locations, Except 220 and 240 V ac Options	CGZ
CSA, Division 2, Except 220 and 240 V ac Options	CNZ
FM, Ordinary Locations	FGZ
FM, Nonincendive, Division 2 Locations	FNZ
Optional Selections	
Storm Door	-7
Special per Engineering Order	-0
Example: 873DPX-AIWFNZ-7	

WIRING DIAGRAM OF 873DPX DUAL/PH/ORP ANALYZERS

(see MI 611-190)

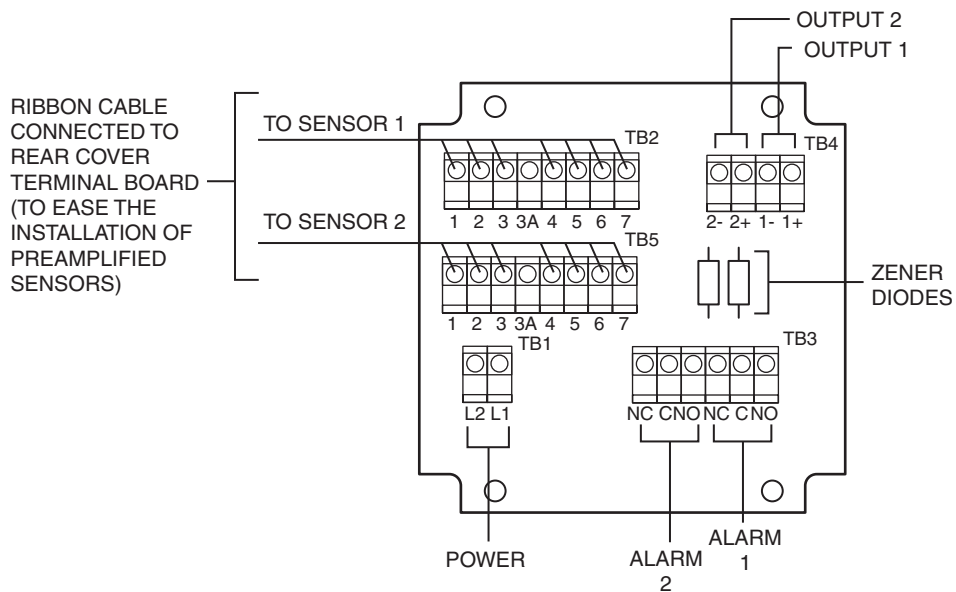



**873 ANALYZER - COMMON SPECIFICATIONS**

(For measurement-specific specifications, refer to the specification page for the appropriate instrument)

**PERFORMANCE SPECIFICATIONS****Accuracy - Temperature Measurement**

±1% of Upper Range Limit

**Accuracy - Temperature Compensation**

±0.2% of Upper Range Limit, based on reference solution

**Linearity**

±0.1% of Upper Range Limit

**Repeatability**

±0.1% of Upper Range Limit

**Drift**

Less than ±0.25% of Upper Range Limit per month, noncumulative

**Zero and Span Interaction**

±0.05% of Upper Range Limit

**Power Supply Effect**

±0.5% of Upper Range Limit for a ±10% voltage shift

±0.75% of Upper Range Limit for a -15% voltage shift

±0.1% of Upper Range Limit for a ±3 Hz frequency shift

## FUNCTIONAL SPECIFICATIONS

**Instrument Response - Measurement**

Two seconds maximum (when zero measurement damping is selected)

**Instrument Response - Temperature**

Five seconds maximum

**Measurement Damping**

Choice of 0, 10, 20, or 40 seconds, configurable via front keypad

**Alarms**

- ▶ Two alarms configurable via front keypad as instrument or measurement/temperature alarms (Hi/Lo, Lo/Lo, Hi/Hi)
- ▶ Individual setpoints continuously adjustable to any point within full scale
- ▶ Adjustable hysteresis for both alarms, 0 to 99% of full scale value configurable via front keypad
- ▶ Dual feed and delay timers with trigger timers, adjustable 0.00 to 99.99 minutes via front keypad

**Alarm Contacts**

Two independent, nonpowered Form C contacts.

Rated 5 A noninductive, 125 V ac/30 V dc.

Minimum current, 1 A

Inductive loads can be driven with external surge absorbing devices across contact terminations.

**RFI Susceptibility****PLASTIC ENCLOSURE**

< 0.5 V/m from 27 to 1000 MHz

**METAL ENCLOSURE**

10 V/m from 27 to 1000 MHz

**Electromagnetic Compatibility (EMC)**

873 Series Electrochemical Analyzers, 220 V ac or 240 V ac systems with metal enclosure, comply with the requirements of the European EMC Directive 89/336/EEC when the sensor cable and power cable are enclosed in rigid metal conduit.

**Isolated Analog Output(s)****PLASTIC ENCLOSURE**

Provides a single analog output

**METAL ENCLOSURE**

Provides dual analog outputs

**NOTE**

Output ranges are continuously adjustable via the front keypad to any values within full scale range (minimum span is 10% of full scale).

**Isolated Output Signal**

Outputs are isolated from earth ground and from each other. Available outputs are 0 to 20 mA dc, 4 to 20 mA dc, or 0 to 10 V dc (individually jumper selectable).

**Isolated Output Load**

CURRENT OUTPUTS (0 to 20 and 4 to 20 mA dc)

800  $\Omega$  maximum

VOLTAGE OUTPUTS (0 to 10 V dc)

1 k $\Omega$  minimum

**Power Consumption**

12.5 W, 20 VA maximum

PHYSICAL SPECIFICATIONS

**Enclosure**

**PLASTIC ENCLOSURE**

Molded, glass-filled, Noryl plastic NEMA 1 enclosure, with a NEMA 12 front panel.

**METAL FIELD ENCLOSURE**

Cast and extruded aluminum, NEMA 4X, CSA ENCL 4X, IEC IP65 enclosure with all exposed surfaces coated with a tough epoxy-based paint.

**Mounting** (also see Dimensions–Nominal section)

**PLASTIC ENCLOSURE**

Panel Mounting only

**METAL FIELD ENCLOSURE**

Panel Mounting, pipe mounting, surface mounting – fixed position, and surface mounting – movable position.

**Dimensions**

See Dimensions–Nominal section.

**Electrical Connections** (also see Dimensions–Nominal section)

**PLASTIC ENCLOSURE**

Terminal strips for power, alarms, sensor input, and output wiring are located on the rear cover.

**METAL FIELD ENCLOSURE**

Conduit fittings for power, alarms, sensor input, and output wiring are located on the bottom surface of the enclosure.

**Approximate Mass**

**PLASTIC ENCLOSURE**

0.68 kg (1.5 lb)

**METAL FIELD ENCLOSURE (with brackets)**

Panel Mounting, 1.54 kg (3.4 lb)

Pipe Mounting, 2.31 kg (5.1 lb)

Surface Mounting – Fixed, 2.22 kg (4.9 lb)

Surface Mounting – Movable, 3.13 kg (6.9 lb)

PRODUCT SAFETY SPECIFICATIONS

Electrical Classification

Testing Laboratory, Types of Protection and Area Classification	Condition of Certification	Electrical Certification Code	Testing Laboratory, Types of Protection and Area Classification
<b>CSA:</b> Ordinary (non-hazardous) locations.	For 24, 100, and 120 V ac (Supply Options –A, –E, and –J only). Temperature Class T6.	CGZ	<b>CSA:</b> Ordinary (non-hazardous) locations.
<b>CSA:</b> Suitable for Class I, Groups A, B, C, and D; and Class II, Groups F and G, Division 2 hazardous locations.	For metal enclosure versions only. For 24, 100, and 120 V ac (Supply Options –A, –E, and –J only).	CNZ	<b>CSA:</b> Suitable for Class I, Groups A, B, C, and D; and Class II, Groups F and G, Division 2 hazardous locations.
<b>FM:</b> Ordinary (non-hazardous) locations.	---	FGZ	<b>FM:</b> Ordinary (non-hazardous) locations.
<b>FM:</b> Nonincendive for Class I, Groups A, B, C, and D; and Class II, Groups F and G, Division 2 hazardous locations.	For instruments with metal enclosure only. Temperature Class T6.	FNZ	<b>FM:</b> Nonincendive for Class I, Groups A, B, C, and D; and Class II, Groups F and G, Division 2 hazardous locations.

**Note:** The Analyzer has been designed to meet the electrical classifications listed in the table above. For detailed information on status of agency approvals, contact Global Customer Support.

OPERATING CONDITIONS

Influence	Reference Operating Conditions	Normal Operating Condition Limits	Transportation and Storage Limits (a)
Ambient Temperature	23 ±2°C (73 ±4°F)	–25 and +55°C (–13 and +131°F)	–40 and +85°C (–40 and +185°F)
Relative Humidity	50 ±10%	50 and 95%	0 and 100%
Supply Voltage	24, 100, 120, 220, or 240 V ac, ±1%	Rated Voltage +10%, –15%	—
Supply Frequency	50 or 60 Hz, ±0.5 Hz	Rated Frequency, ±5 Hz	—
Vibration	Negligible	1 “g” (10 m/s <sup>2</sup> ) from 5 to 200 Hz	Protected by Shipping Container
Mechanical Shock	—	—	1.1 m (41 in) Drop while in Shipping Container

a. Instrument may require adjustment to restore specified performance upon placing into operation within normal operating condition limits.

**OPTIONAL FEATURES****Storm Door**

This door is attached to top front surface of the enclosure. It is used to prevent accidental or inadvertent actuation of front panel controls, particularly in field mounting applications. The door is clear plastic to allow viewing of the display when closed, and also hinged to allow ready access to front panel controls. Specify Optional Selection –7.

**Curve Generation Program**

This option is offered for the contacting conductivity (873CC) and electrodeless conductivity (873EC) instruments only. This option allows nonstandard temperature compensation curves, as well as nonstandard conductivity-to-% concentration transforms for certain chemicals, not already programmed in, to be entered via the keypad. Specify Optional Selection –5.

DIMENSIONS-NOMINAL

$\frac{\text{mm}}{\text{in}}$

GENERAL PURPOSE ENCLOSURE - PANEL MOUNTING

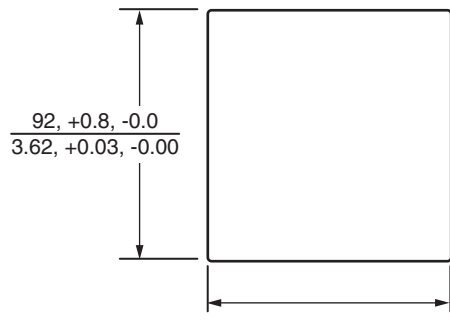
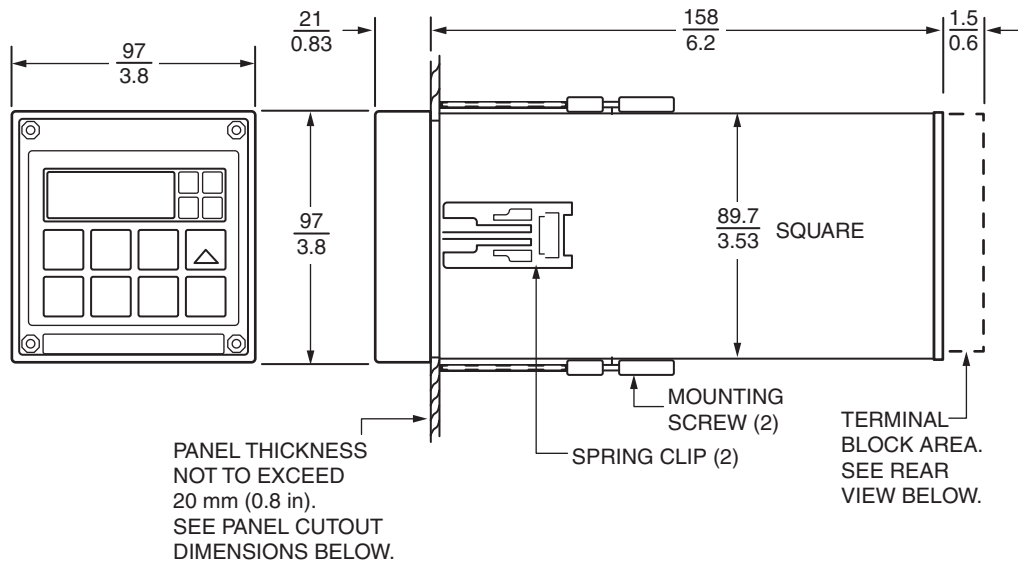

PANEL CUTOUT

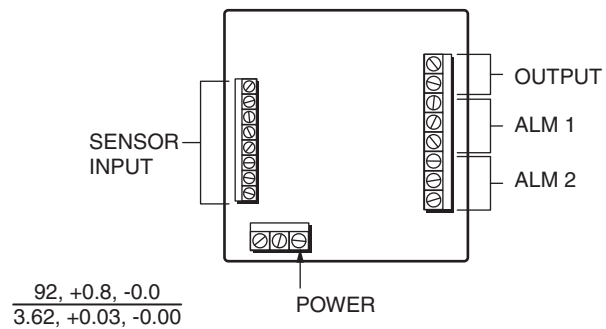

REAR VIEW

mm  
in

FIELD ENCLOSURE - PANEL MOUNTED

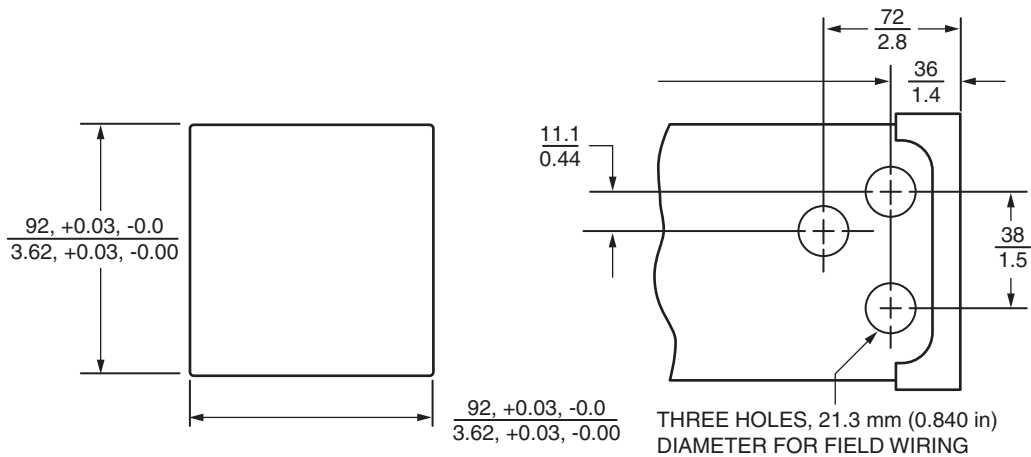
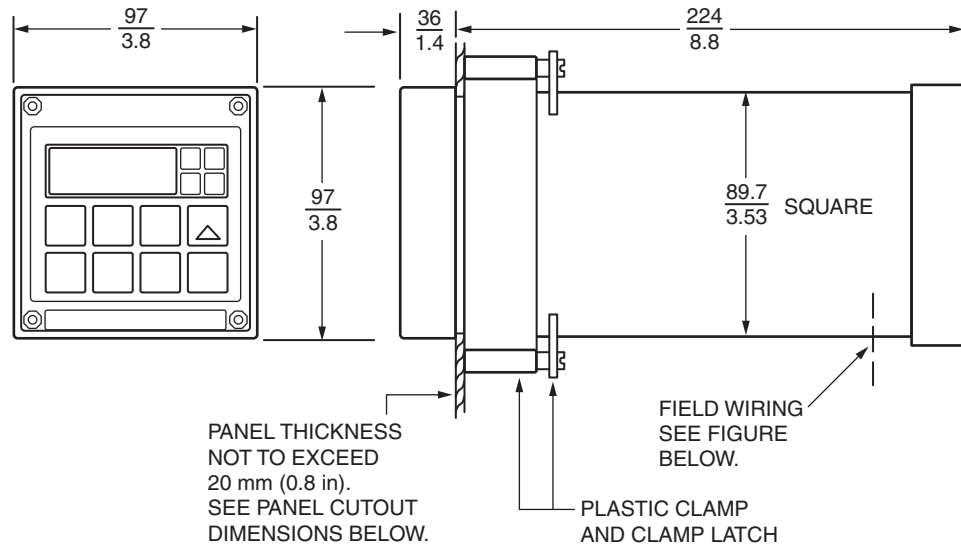

PANEL CUTOUT

BOTTOM VIEW

NOTE

SEE THE NEXT PAGE FOR SURFACE MOUNTING - FIXED AND PIPE MOUNTING OF THE FIELD ENCLOSURES. DIMENSIONS AND FIELD WIRING HOLES ARE THE SAME FOR ALL FIELD ENCLOSURES.

$\frac{\text{mm}}{\text{in}}$

FIELD ENCLOSURE - SURFACE MOUNTING - FIXED

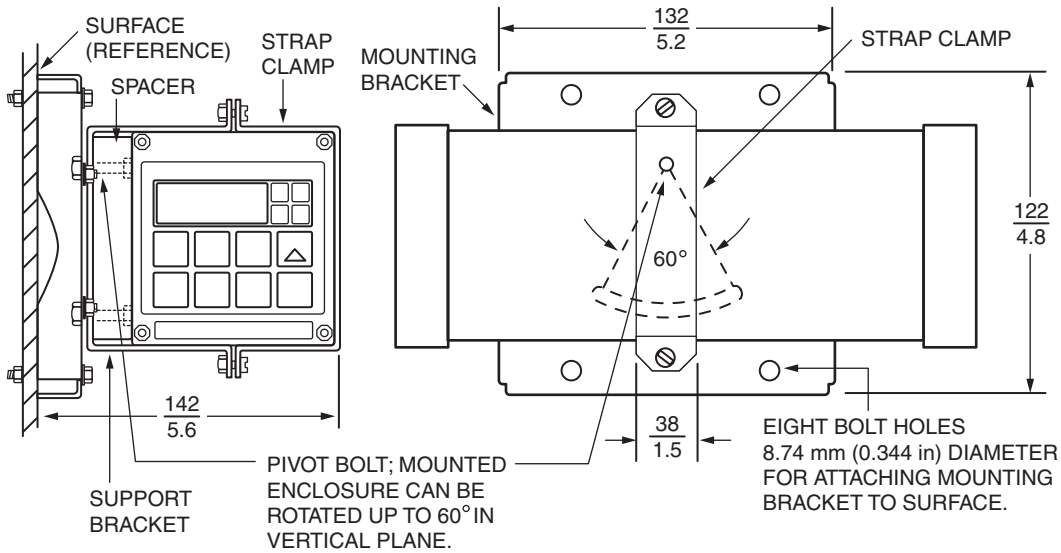

FIELD ENCLOSURE - PIPE MOUNTING

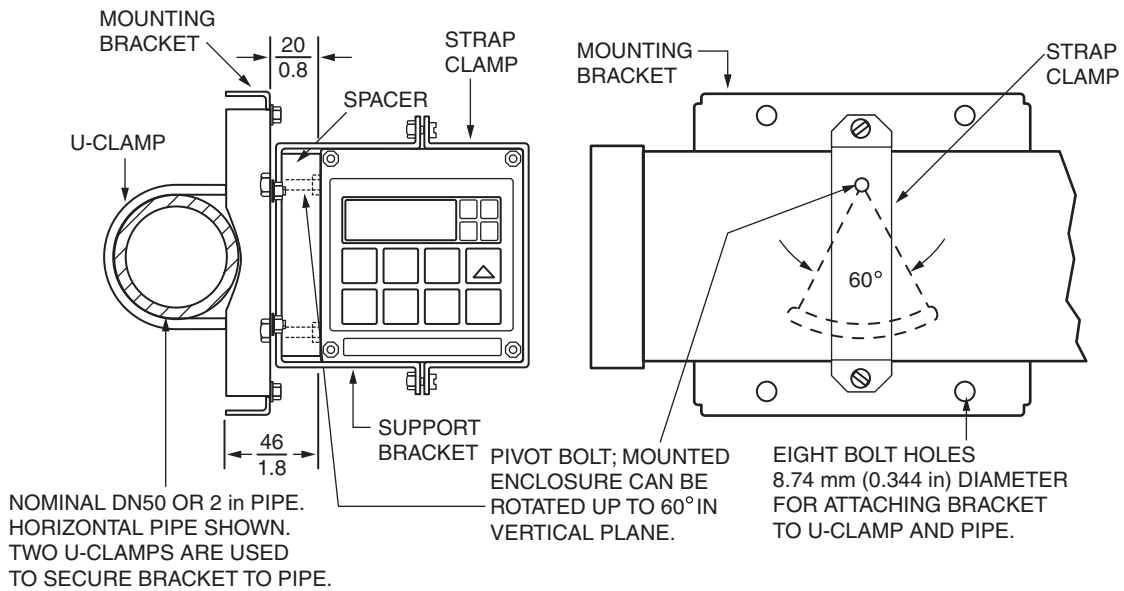



**mm**  
**in**

FIELD ENCLOSURE - SURFACE MOUNTING - MOVABLE

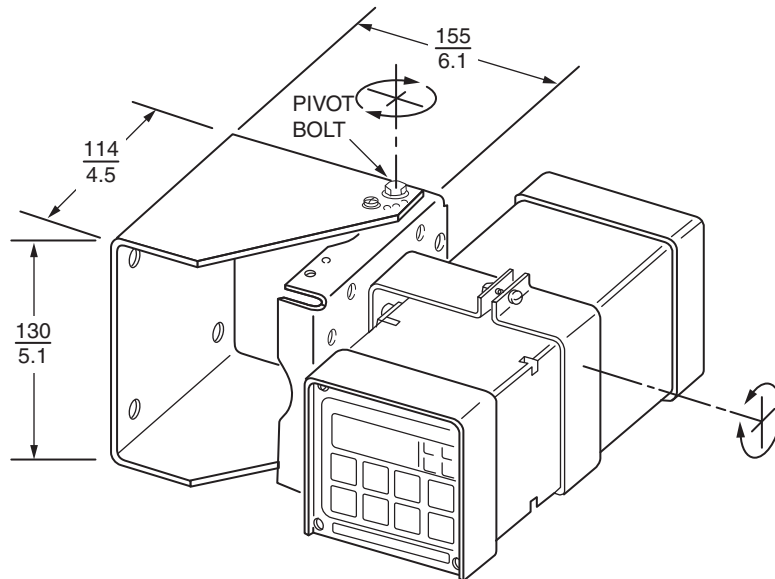
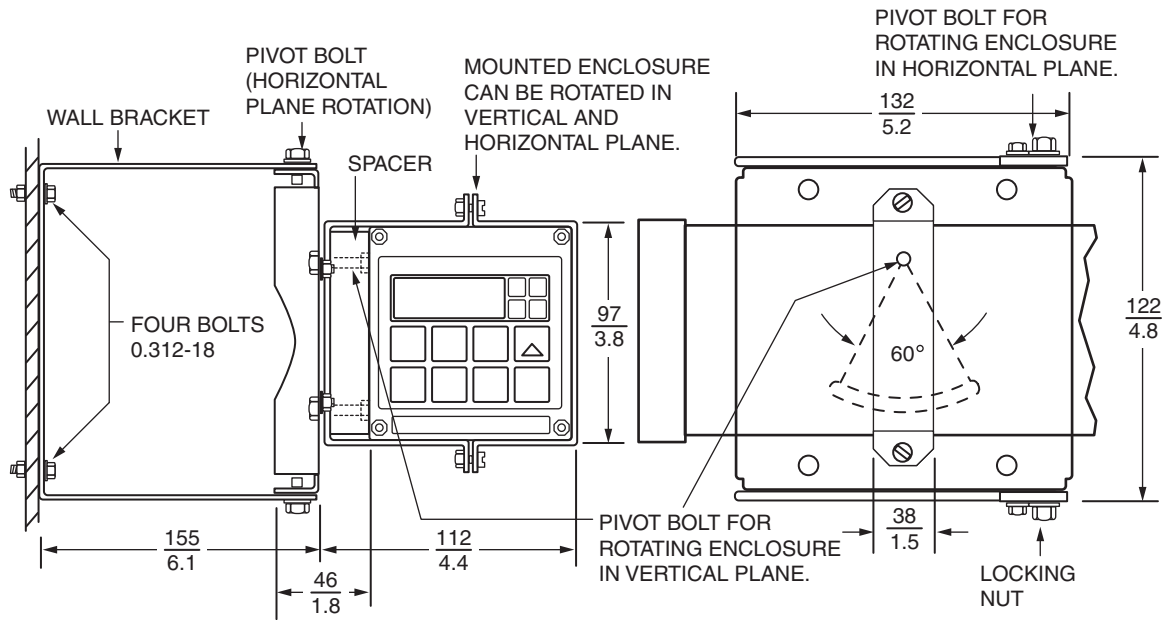

**NOTES**



## ORDERING INSTRUCTIONS

1. Model Number
2. Measurement Range (for 873DPX, specify for Sensor Input 1 and Sensor Input 2)
3. Measuring Electrode Type (for 873PH and 873DPX only)
  - a. For 873PH:  
Glass pH, Antimony pH, or ORP
  - b. For 873DPX (specify one each for Sensor Input 1 and Sensor Input 2):  
Glass pH, Antimony pH, ORP, or ISE (specify type)
4. For 873EC only, specify Sensor Type: -SP, -RE, -LB, -HP, -BW, -UT, -NL, -TF, -EV, or 871FT (full Model Code).
5. Temperature Compensation Input for 873RS, 873CC, and 873EC only  
(100 k $\Omega$  thermistor or 100  $\Omega$  RTD)
6. User Tag Data and Application

## ADDITIONAL PRODUCTS

These product lines offer a broad range of measurement and instrument products, including solutions for pressure, flow, analytical, temperature, positioning, controlling, and recording.  
For a list of these offerings, visit our web site at:

[www.schneider-electric.com](http://www.schneider-electric.com)

Schneider Electric Systems USA, Inc. Global Customer Support  
38 Neponset Avenue Inside U.S.: 1-866-746-6477  
Foxboro, MA 02035 Outside U.S.: 1-508-549-2424  
United States of America <https://pasupport.schneider-electric.com>  
<http://www.schneider-electric.com>

Copyright 1992-2018 Schneider Electric  
Systems USA, Inc. All rights reserved.

Schneider Electric is a trademark of Schneider  
Electric Systems USA, Inc., its subsidiaries, and  
affiliates. All other trademarks are the property  
of their respective owners.

